

Commitment to Customer Service

"Our Goal is to Help You Achieve Yours"



UKAS Laboratory



Technical Support & Product Specialists



Training Facilities



Quality - Product "Traceability"

Cromwell has complete **ISO9001** certification and has fully qualified assurance and staff.

Ethical & Sustainable

Cromwell makes every effort to ensure all products are manufactured in conformance with good employment practice and in keeping with its **ISO14001** standard for the use of sustainable resources.

Product Support

Product and application advice is available from all of our distribution centres worldwide. The local teams have further support from our specialist technical division and application engineers who provide advice, training, CAD design, tooling packages and R&D to suit customer requirements.

Product & Service

Quality Assurance



Commercial

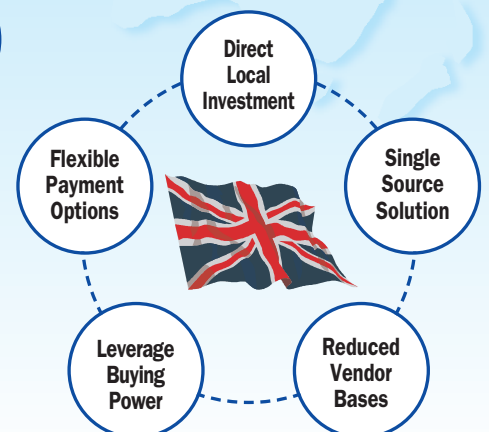

Consolidation - Reduce your Purchasing Costs

Consolidating all your consumables spend with Cromwell can save you money by reducing the costs associated with dealing with multiple suppliers. With over 24,000 products in this catalogue and access to thousands more (see www.cromwell.co.uk), Cromwell can supply all your consumable needs, allowing you to control your spend whilst guaranteeing quality, performance and continuity of supply.

e-commerce - Downcost your Supply Chain



B2B Business to Business (Web Trading)

Secure login. View own pricing. Individual user configuration. Customer's own administrator. Complete budgetary controls. On line sales and invoice history. Individual user shopping lists. Standard and draft order functionality.

- Bespoke Catalogues
- Order Approvals
- Budgetary Control
- Access to Order History
- Comprehensive Reporting Suite
- Request for Quotation
- User Configuration
- Personalised Home Page
- Access to SDS Sheets

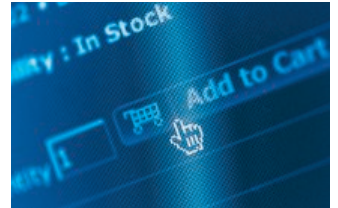

Supply Chain



- Advanced Stock Management Systems ensure "Local Ex-stock Availability".
- Established re-supply chain by air, sea and overland freight movement from the World Distribution Centre to our local distribution centres.
- Courier services for urgent or non-standard supply requirements.
- Proven freight forwarding and logistics partnerships.
- Local support from our worldwide network of Distribution Centres and dealers.



Global Sourcing

Global Sourcing of Manufactured Products:

- | | |
|--------------------|---------------|
| Injection Moulding | CNC Machining |
| Drop Forging | Casting |
| Fabrication | Woodworking |
| Textiles | Electronics |

Sourcepoint was established to help customers of Cromwell source more competitively. Access to a global supply base helps reduce cost and improve product availability, with established sources across **Europe, India, China, Australasia, Africa and South East Asia.**

Our presence as both a global supplier and purchaser brings knowledge and

experience when finding new sources around the world, from identification through to product inspection.

Enquiries for all types of component, product or material will be considered. We have understanding of most production methods and legislation including **RoHS** and **REACH**, as well as a **UKAS** accredited calibration laboratory.

This new business can be combined with our regular shipments from around the globe to reduce costs. Our local network of contacts and partners can also buy products on our behalf with further knowledge at a ground level.

Globally Sourced Products To Your Door



How to Order

When choosing products from our catalogue, please select the "Order Codes" by following the example shown here.

1. Note the six figure "Product Group" code

Number of Pieces	Weight	Order Code	List Price/1	Offer Price/1
6	620g	ABC-123-4567D	-	-

2. Add the remaining five figure "Item" code

Now with your complete Order Code, simply add your desired quantity and our friendly and experienced sales team are ready to take your order.

e.g. Order Code: **ABC-123-4567D**
Quantity: **1**

Pricing - Quality Industrial Supplies at Very Competitive Prices

List Prices All list prices are based on current manufacturing costs, ex-works and exclude VAT and other Government levies. Quotes remain valid for 30 days only, unless by written agreement and subject to change in line with increase in manufacturing and supply chain costs.

Discounts Customers can negotiate purchase discounts on products where they have a regular or high volume usage. Discount levels are subject to agreement with our local dealer/distributor, or local Cromwell branch and are relevant to volumes being purchased.

Cancellation & Return Policy

Cancellations

Orders cannot be cancelled once they have been despatched by Cromwell or one of its suppliers. For products requiring special manufacture, cancellation will not generally be allowed once the manufacturing process has commenced.

Returns

Products may be returned to Cromwell for credit or refund by way of the following procedure;

- 1 A returns number or authorisation should be obtained from Cromwell prior to returning goods, advice note or invoice number needs to be quoted.
- 2 Products must always be returned unused in their original packaging and in a condition that is immediately fit for resale.
- 3 Returns must be made within 14 days of the advice note date of delivery unless special authorisation has been agreed.

Conditions

- (i) A re-stocking charge will generally be applied for products that are no longer required or returned due to customer error.
- (ii) Certificated/calibrated products may not be eligible for return due to conformity regulations included in our accreditation certification.
- (iii) Cromwell reserves the right to refuse to accept any products or to apply a re-stocking charge that relates to the actual cost of inspection and re-stocking for products returned that do not comply with the terms of this policy.

This policy excludes software products and/or products supplied under contract where the terms and conditions of the contract will rule.

This policy is part of our terms and conditions of sale but does not affect the customer's statutory rights as a consumer. Cromwell accepts no responsibility for any loss or damage to products in transit.

ALL RETURNS ARE SUBJECT TO 100% INSPECTION BEFORE RE-STOCKING TO ENSURE GOODS ARE FIT FOR RESALE.



Product Promotions

Special Offers are published regularly to pass on substantial savings on products that Cromwell have produced in volume. Leaflets are freely available from your local branch or representative.

Prices are Correct at Time of Printing

Please contact us for latest pricing and details of our product promotions.

PRICES RULE AT THE DATE OF DESPATCH.

Supplier of Quality Brands...

KENNEDY
PROFESSIONAL

SWISS+TECH

OXFORD
PRECISION

YORK
ABRASIVES

AVON

INDEXA

RUTLAND
Quality Gardening Tools

SOLENT
MAINTENANCE

MATLOCK

SHERWOOD
QUALITY CUTTING TOOLS

KOBE

TUFFSAFE
PROTECTION AT WORK

Catalogue Overview

We have also included a fully comprehensive and very useful "Alphabetical Index" on pages 6 - 15.

CUTTING TOOLS

Product Groups
005 - 184

Contents Pages: 16 - 17

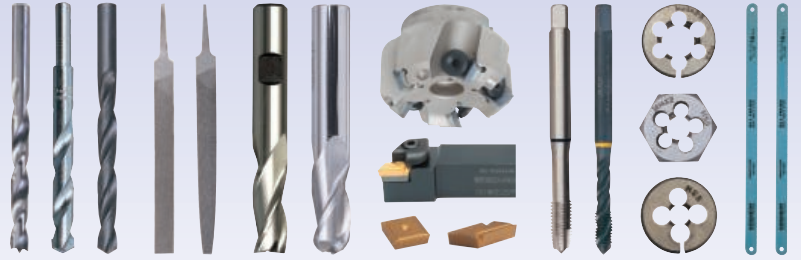

ABRASIVES & POWER TOOLS

Product Groups
200 - 298

Contents Pages: 164 - 165



PRECISION EQUIPMENT

Product Groups
300 - 385

Contents Pages: 244 - 245



WORKSHOP EQUIPMENT

Product Groups
400 - 495

Contents Pages: 274 - 275



HAND TOOLS

Product Groups
501 - 603

Contents Pages: 320 - 321



FASTENERS

Product Groups
600 - 690

Contents Pages: 612 - 613

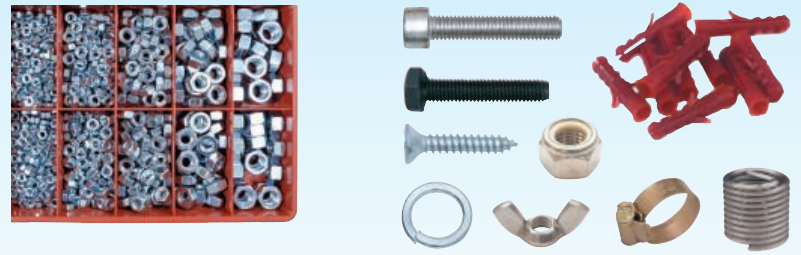

To ensure that users can find the right product as quickly as possible all products have been catalogued in order of “Product Group” sequence. The “Groups” featured on each page are clearly identified in the outside corner at the top of each page. Furthermore, a complete list of the “Groups” featured in each section of this catalogue is given on the “Section Contents Pages” at the beginning of each section.



LUBRICANTS & CHEMICAL PRODUCTS



Product Groups 708 - 742

Contents Pages: 644 - 645



JANITORIAL & HYGIENE



Product Groups 780 - 952

Contents Pages: 662 - 663



OFFICE SUPPLIES & PACKAGING



Product Groups 800 - 982

Contents Pages: 678 - 679



WELDING

Product Groups 880 - 891

Contents Pages: 700 - 701



SITE MAINTENANCE



Product Groups 741 - 996

Contents Pages: 714 - 715



PERSONAL PROTECTION

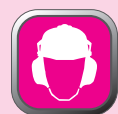

Product Groups 957 - 963

Contents Pages: 764 - 765

A

Absorbent Granules	728
AC90	653
Access Barriers	761
Access Platforms	759
Adaptors, Face Mill	157, 160
Morse Taper	157, 160, 203
Shank	157, 161, 297
Sidelock	157
Tapping	162 - 163
Adhesive Removers	650
Sprays	647
Spreaders	415
Adhesives, Instant	647
Structural	647
Tape	695, 697
Adjustable Hook Wrenches	159
Spanners	322 - 324
Spanners, Insulated	418
Air Duster, Aerosol	681
Fresheners	667
Hose Balancers	194
Preparation Equipment	195
Tool Accessories	194
Airflow Meters	250, 372
Airline Couplings	196 - 199, 240 - 241
Gauges	194
Hoses	194
Lubricators	195
Pressure Gauges	194
Aluminium Tool Cases	562, 566
Aluminium-Oxide Cloth	166
Aluminium-Oxide Paper	166
Anemometers	250, 372
Angle Finders	605
Finders, Digital	262
Grinders, Air	208, 212, 217
Grinders, Electric	232
Plates	272
Anti-Freeze Testers	350
Anti-slip Floor Products	647, 741, 752
Anti-Spatter Fluids	655, 711
Aprons, Carpenters	558
Aprons, Plastic	794
Arbors, Holesaw	61
Arbors, Morse Taper	161
Arc Welders	702
Archive Boxes	680
Ashtrays	674
Asphalt Rakes	391
Attache Cases	680
Auger Bits	603
Automotive Fuses	325
Automotive Wire Splicing Kit	325
Axes	401
Axis Gauging Equipment	248
Axle Stands	337

B

Back Supports	791
Backing Pads	168 - 169, 234
Bag Sealers	695
Bags, Gripseal	689
Laptop	561, 680
Polythene	689
Sand/Filter	671
Woven Polypropylene	674, 689
Ball Joint Service Tools	342
Ball Pein Hammers	399
Balls, Steel	640
Banding Materials & Tools	690 - 691
Banding Tools	690
Barn Type Tool Boxes	570
Barrier Chains & Posts	760
Barrier Creams	664, 666
Barriers, Access	761
Portable	761
Tape	752
Base Fixturing Components	293 - 294
Bases, Magnetic	263 - 265
Basin Wrenches	549
Batteries	730
Batteries & Chargers for Cordless Tools	230 - 231
Battery Chargers, Automotive	346
Battery Testers	325
Beam Clamps	736
Beard Masks	794
Bearing Separators	342 - 343
Belt & Disc Sanders, Electric	233
Dressing Sprays	654
Sanders, Air	218

Belt Skimmers, Tramp Oil	661
Bench Drills	223
Grinders	227, 232
Grinders Accessories	232
Hooks	599
Magnifiers	253
Shears	314
Benches, Work	280
Bent Nose Pliers	457
Bevel Protractors	257
Bevels, Carpenters	605
Bicycle Tools	596
Bi-Directional Flow Regulators	241
Bi-Metal Holesaws	60 - 61
Binoculars	254 - 255
Bins, Cigarette	674
Bits, Auger	603
Flat	604
Forstner	603
Blacksmiths Drills	35
Blade Fuses	325
Blades, Coping Saw	58, 430, 599
Hacksaw	58 - 59, 430
Jigsaw	184 - 185
Knife	425, 428 - 429
Tile Saw	58, 430
Bleach	667 - 668
Block Planes	600
Blow Guns, Air	201
Body Repair Kits	326 - 328
Saw Blades	214
Warmers	798
Bodywork Tools	327 - 328, 338, 350
Boiler Suits	795
Bolt Clamps	642
Bolt Cutters	554
Bonnets, Polishing	169, 234
Booster/Starter Cables	346
Boots, Safety	804 - 807
Boots, Wellington	805
Bore Gauges, Dial Indicating	266
Boring Bars, Indexable	130 - 133
Bossing Mallets	402
Bottle Jacks	336
Bottle Oilers	438
Bouffant Caps, Disposable	794
Bow Saws	388
Box Spanners	494
Boxes, Archive	680
Bradawls	603
Brake Cleaner Spray	649
Brake Tools	330 - 331
Brazed Tools	114 - 115
Breast Drills	605
Bricklaying Tools	352 - 353, 357, 399
Brief Cases	680
Brooms	670, 672
Brushes, Artists	411
Car Wash	671
Decarbonising	243, 348
Decorators	411, 414
Fitch	411
Hand	411, 414, 670, 672
Laminating	411
Nail	669
Paint	410 - 411
Radiator	411
Sash	411
Scrubbing	671 - 672
Slimline	734
Spark Plug	348
Suds	411
Suede	669
Toilet	669
Tube	734
Buckets	357, 396, 414, 671
Buckets, Mop	671, 673
Buffing Pads	235
Builders PVC Tapes	697
Builders Trowels	356
Bump Caps	767
Bungee Load Straps	753
Burrs, Carbide	174 - 177
Burrs, Diamond Coated	177, 229
Bush Removal Tool, Automotive	349
Business Card Holders	680
Butane & Propane Gas Equipment	366 - 367
Butt Welded Turning Tools	18
Button Head, Socket Screws	625 - 626, 629



Cabin Hooks	747
Cabinet Scrapers	601
Cabinets & Work Benches	280
Cabinets, Key	683
Cable Reels	236
Strippers	364
Tie Tools	363
Ties	363
Tools, Insulated	419
Calculators	684
Caliper Attachments	259
Calipers, Dial	257 - 258
Digital	260 - 261
Firm Joint	377
Spring	377
Vernier	259
Cantilever Tool Boxes	570
Cap Screws, Socket Head	614 - 619, 627, 629
Car Battery Chargers	346
Care Products	649, 667, 671
Creepers	334
Carabiner Hooks	755
Carbine Hooks	755
Card Holders, Business	680
Cargo Straps	753
Carpenters Aprons	558
Carpenters Pincers	455
Carton & Strapping, Cutters	426, 699
Carton Openers	426, 699
Cartridge Roll Mandrels	172
Rolls	172
Rolls, Abrasive	172
Cash Boxes	683
Castors, Wheel	738 - 739
Centre Drill Sets	26
Drills	26 - 27
Finders	373
Punches	380
Centres, Revolving	317
Centres, Solid	317
Chain & Drive Lubricants	651 - 652
& Rope Fittings	754 - 755
Barrier	760
Hoists	736
Hooks	755
Pin Extractors	549
Repair Links	754
Chain, Steel	754
Chain Wrenches	340, 507, 549
Chairs, Industrial	682
Chairs, Office	682
Chalk Lines	601
Chalks	734
Chamois	669
Channel Blocks	668
Chargers & Batteries for Cordless Tools	230 - 231
Chaser Dieheads	19
Chaser Dies	19
Chicken Wire	397
Chisels, Cold	351 - 353, 400
Power Tool	239
Wood	602 - 603
C-Hook Spanners	159, 492, 507
Chuck Jaws, Lathe	315, 318
Keys	297
Keys, Lathe	315
Chucks, Drill	296
ER Collet	158
Keyless, Drill	206, 296
Lathe	315
Pin	385
Cigarette Waste Bins	674
Circlips	632, 640
Circuit Board Drills	25
Circuit Testers	325, 363
Circular Saw Blades, HSS	90, 235
Circular Saws, Electric	226
Clamp Meters	371
Clamping Sets, T-Slot	282 - 283
Clamps, Beam	736
Bolt	642
Corner/Frame	432, 599, 708
G	432
Hose	331
Quick Grip	433 - 434
Rack	280
Saddle	643
Sash	433
Speed	434, 462
T Handled	435
Toggle	299 - 305
Toolmakers	385
Claw Hammers	398

Cleaners, Compressed Air	681
Coolant System	661
Degreasing	648, 650, 654
Electrical	650
Floor	667
Foaming	650
Hand	664 - 666
Hard Surface	667
Rapid Drying	650
Solvent	650
Vacuum	233
White Board	681, 686
Cleaning Cloths & Sponges	415, 669, 673
Cleaning Wipes	762
Clevis Pins	633
Clipboards	680
Clips, Hose	642
Spire	631
Terry	643
Clocks	684
Clothing	713, 767, 795 - 803
Cloths, Cleaning	415, 669, 673
Club Hammers	401
CNC Tool Storage	156
Coat Hooks	745
Coil Spring Compressors	342
Cold Chisels	351 - 353, 400
Collet Chucks ER	158
Collets for Air Grinders	208, 211
Collets, Rubberflex	161
Single Angle	159
Straight	229
Type R8	157
Combi-Kits, Cordless	230
Combination Drill Tap, HSS	38
Pliers	450 - 451
Sets	257, 605
Spanners	494 - 500
Component Protection	646
Compressed Air Dusters	681
Compression Tester	331
Compressors	224
Computer Screen Wipes	681
Containment Storage	716 - 719, 728 - 729
Continuity Testers	325
Contour Gauges	415
Contractors Tools	389
Converters, Square Drive	511, 515, 519, 521
Coolant Hoses	311
Pumps	661
System Accessories	661
System Cleaners	661
Cooling System Tester	331
Coping Saws & Blades	58, 430, 599
Copper Grease	654
Hammers	406
Washers	631
Copper/Rawhide Hammers	406
Cord, Sash	753
Cordless Power Tools	230 - 231
Cordless Tool Batteries & Chargers	230 - 231
Core Bits	63
Corner Clamps	432, 599, 708
Corner Rounding Cutters, HSS	65
Corrosion Protection	653, 697
Counter Measure	375
Counterbores, HSS	24
Counters, Hand Tally	251
Countersinks	20 - 23
Couplings, Airline	196 - 199, 240 - 241
Coveralls, Workwear	799
Cranes	737
Creepers, Car & Garage	334
Crimping Tools	358 - 362, 365
Cross Pein Hammers	400
Crowbars	353
Crowfoot Wrenches	506
Cut Resistant Sleeves	788
Cut-Off Wheels	180 - 181, 229
Cutters, Fibre Optic	365, 416
Pipe	544 - 545
Router	238
Side	365, 455, 554
Strapping & Carton	426, 699
Wire	454
Cutting Compounds	101, 652
Discs	180 - 181, 229
Fluids	660
Nozzles, Welders	708
Cycle Tools	596
Cylinder Trolleys, Gas	710

D

Data/Reference Books	813
Dead Blow Hammers	403, 405
Dead Locks	744
Deburrer, Pipe	545
Deburring Tools, Hand	134 - 137
Decarbonising Brushes	243, 348
Decorators Brushes	411, 414
Decorators Dust Sheets	414
Dee Shackles	755
Degreasers	648, 650, 654
De-Icer, Windscreen	649
De-ionised Water	651
Delta Sanding Sheets	169
Depth Gauges, Digital	261
Gauges, Scale	378
Micrometers	270
Descaler & Hammer Accessories	213
Descalers & Hammers, Air	213
Desoldering Tools	368
Detectors, Voltage	364, 370
Detergents	668
Dewatering Fluids	653
Dial Calipers	257 - 258
Indicating, Bore Gauges	266
Indicator Spares	246 - 247
Test Indicators, Lever type	247
Test Indicators, Plunger Type	246
Diamond Hand Files	57
Diamond Wheel Dressers	319
Die & Mould Cutters	83 - 85
& Tap Sets	105
Grinders, Air	208 - 211
Nuts, Metric Fine	94
Springs	312 - 313
Stocks	383
Dieheads, Chaser	19
Diemakers Riffler Files	55
Dies & Die Nuts, HSS	92, 94, 96 - 106
Dies & Die Nuts, Left Hand, HSS	93
Dies, BSW	99
Chaser	19
Metric Coarse	92 - 94
UNC	96
Digital Calipers	260 - 261
Digital Indicators	262
Disinfectant	667
Dispensers, Packing Materials	688
Soap & Hand Cleanser	664 - 665
Tape	695
Dispensing Bottles	438
Disposable Bouffant Caps	794
Gloves	790
Knives	424
Dividers, Spring	377
DIY Power Tools	228
Document Pockets	680
Dollies, Panel Beating	326
Door & Gate Furniture	745 - 747
Bolts	745 - 746
Closers	742
Handles	744, 747
Locks	744 - 746
Mats	670
Double Sided Tapes	698 - 699
Dovetail Cutters, HSS	65
Dowels, Steel	633, 640 - 641
Drain Rods	550
Drainer, Oil	439
Dressers Wheel, Diamond	319
Dressers Wheel, Huntington	319
Dressings & Plasters, Medical	762
Drill & Tap Sets, HSS	35, 38, 95
Blanks, HSS	43
Chucks	296
Drifts	316
Gauges	378
Press Vices	306 - 307
Sets, Maintenance	35
Sleeves, Morse Taper	316
Tap Combination, HSS	38
Drilling & Milling Machines	222
Drilling & Tapping Lubricant	101, 652
Drills, Air	205 - 207
Bench	223
Blacksmiths	35
Breast	605
Carbide, Spotting	24
Centre	26 - 27
Circuit Board	25
Cordless	230 - 231
Extra Length	47, 49
Hand	605
Impact, Electric	227

Drills, Jobber	34, 36 - 44
Long Series	45 - 46
Masonry Bits	62
Pillar	223
SDS-Plus Bits	63
Sheet & Tube	20
Sidewinder Bits	604
Spotting	24
Stub	25, 29 - 31
Taper Shank	48 - 49
Venting	25
Drip Trays, Oil	439
Drop Head Threaders	547
Drum Taps	437
Drum Trucks	439
Dry Wipe Boards & Accessories	687
Dust Sheets, Decorators	414
Dustbins	674
Dusters	669

E

Ear Defenders	766, 768
Ear Plugs	768
Easyline Markers	657
Edge Finders	373
Ejector Springs, Holesaw	61
Elbow Connector to Stem	240
Joint Stand	264
Pads	791
Electrical Cleaner Sprays	650
Electrical Terminals	358 - 359
Electrodes, Welding	703 - 704
Emergency Hammers	683
Emery Cloth	167
End Mills	66 - 69, 73, 76 - 82, 84 - 85
Engine Tools, Specialist	345, 348 - 349, 531
Engineers Hand Files	51 - 53
Hooks & Picks	385
Marking Blue	657
Scrapers	385
Squares	270, 376
Vices	310
Engraving Pens, Electric	226
Environment Meters	250, 369, 372
Euro Nesting Bins	277
Exhaust Mount Pull Hook	350
Explorer Cases	561
Extension Bars, Square Drive	510, 513, 517, 521 - 522
Extension Sockets, Morse Taper	316
Extra Length Drills	47, 49
Extractors, Screw	90
Eye Loupes, Magnifying	252 - 253, 382
Protection	712, 772 - 777
Wash Stations	762

F

Face Masks	769 - 771
Mill Adaptors	157, 160
Protection	766 - 767, 777
Shields, Welders	712
Fall Arrest Equipment	792 - 793
Feeler Gauges	379
Feeler Stock	379
Felt Bobs, Cones & Sticks	188 - 189
Fencing	397
Fencing Tool	390, 455
Fibre Optic Cutters	365, 416
Vice Jaws	551
Washers	632
File Handles	52, 407
Files, Diamond	57
Diemakers Riffler	55
Engineers Hand	51 - 53
Milled Tooth	56
Needle	54
Rasps	56
Thread Restoring	19, 97
Filling Knives	408
Finders, Centre	373
Finders, Edge	373
Fire Blankets	762
Firm Joint Calipers	377
First Aid Equipment	762 - 763
First Aid Kits	763
Fitch Brushes	411
Fixit Kits	626 - 635
Fixturing Components	293 - 294
Flap Discs, Abrasive	179, 189
Flap Wheels, Abrasives	178, 189
Flared Nut Ring Spanners	503
Flaring Tools, Pipe	546
Flash Drives	680
Flat Bits	604

Flat Stock, Ground	281
Flawfinders	654 - 655, 711
Fleece Jackets	796 - 797
Floats	355
Floodlights	237
Floor Cleaners	667
Matting	740 - 741
Paints	647
Scrapers	391
Fluids, Grinding	660
Fluteless Taps	93, 97, 104, 112
Foam Cleaner Sprays	650
Folding Rules	605
Folding Trolleys	758
Food Industry Lubricants	658 - 659
Foot Pumps	201, 347
Footwear, Safety	804 - 807
Force Feed Oil Cans	438
Forks, Garden	386
Forstner Bits	603
Fount Sets	465
Frame Clamps	432, 599, 708
Fuel Containers	346
Pump Testers	331
Transfer Pumps	437
Funnels	436
Fuses, Automotive	325

G

Galvanising Paint	653
Garage Creepers	334
Garden Hose Fittings	393 - 395
Mesh	397
Refuse Bags	357, 396
Shelters, Folding	397
Sprayers	392, 394 - 395
Waste Bags	396
Gardening Tools, Hand	386 - 388
Gas Bottles, Welding	706
Regulators, Welding	706, 710
Welding & Cutting	708, 710
Gauge Plate	281
Gauges, Air Pressure	194
Airline Pressure	194
Contour	415
Depth	378
Drill	378
Feeler	379
Height, Dial & Digital	257
Hole	379
Marking	602
Mortice	602
Radius	378
Screw	378
Slip	271
Surface	384
Taper Bore	375
Telescopic	376
Thickness	257
Wire	378
Gauging, 3D Axis	248
Gauntlets, Welders	713, 789
Gazebos, Folding	397
G-Clamps	432
Gear Oils	654
Generators, Power	224
Glass & Tile Drills	62
Cleaners	649, 668
Paper	166
Gloves, Abrasion Resistant	786 - 787
Chemical Resistant	787, 790
Disposable	790
General Handling	713, 780 - 785, 789
Goatskin	782
Latex	788
Nitrile	786 - 787
PVC	786
Rigger	780
Tear Resistant	788 - 789
Welders Gauntlets	713, 789
Goggles, Safety	775 - 776
Graffiti Remover	667
Granite Parallels	249
Squares	249
Straight Edges	249
Surface Plates	249
Vee Blocks	249
Granules, Absorbent	728
Grass Shears	388
Grease	660
Grease, Copper	654
Grease Guns	438 - 441
Nipples	442
Pumps	438 - 439
Grinding Compounds	188, 229

Grinding Discs	180 - 181
Fluids	660
Wheels	183, 229
Grip Wrenches	460 - 463
Gripseal Bags	689
Grommets	632
Ground Flat Stock	281
Grout Removers	415
Gun-nose Taps	93, 95, 97 - 102, 108 - 112

H

Hacking Knives	409
Hacksaw Blades	58 - 59, 430
Hacksaw Frames	430 - 431
Hairnets, Workwear	794
Halogen Heaters	685
Hammer & Descaler Accessories	213
Shafts	407
Wedges	407
Hammers & Descalers, Air	213
Hammers, Aluminium	406
Ball Pein	399
Brick	399
Claw	398
Club	401
Copper	406
Copper/Rawhide	406
Cross Pein	400
Dead Blow	403, 405
Emergency	683
Machinist	398
Magnetic	400
Nylon Faced	404 - 406
Planishing	402
Plastic Faced	404 - 406
Rawhide	406
Rubber	405
Scutch	400
Sledge	401
Welders Chipping	400
Hand Conditioning Creams	664
Deburring Tools	134 - 137
Drills	605
Files, Diamond	57
Files, Engineers	51 - 53
Files, Milled Tooth	56
Files, Needle	54
Files, Rasps	56
Magnifiers	252
Pads, Abrasive	186
Shovels	670
Soaps & Cleaners	664 - 666
Stamps	464 - 465
Tackers	692
Tally Counters	251
Taps	92 - 104
Taps, Left Hand	93
Towel Dispensers	677
Towels & Wipes, Paper	677
Wipes, Wet	666, 675
Handles, Door	744, 747
File	52, 407
Torque	445
Hard Hats	767
Hardness Testers, Bench	248
Hasps	747
Hatchets	401
Hats, Mob Cap	794
Hawks, Plasterers	355
Hazard Marking Tapes	752
Head Protection	766 - 767, 795
Hearing Protection	768
Heat Guns	226
Sealers	695
Shrink Tubing	359
Heaters, Convactor	685
Fan	685
Halogen	685
Height Gauges, Dial & Digital	257
Helicoil Inserts	636
Helmets, Safety	767
Helmets, Welders	712, 777
Hexagon Wrenches	150 - 151, 606 - 610, 617, 621, 624
High Tensile Threaded Bar	638
Hinges	745 - 746
Hi-Visibility Fencing	397
Hi-Visibility Workwear	800 - 803
Hoes	387
Hoists, Chain	736
Holdalls	560
Holdalls, Business Card	680
Holdalls, Magnetic	444
Hole Cutters, Adjustable	603
Hole Gauges	379
Holesaw Arbors	61

Holesaw Ejector Springs	61
Holesaws, Bi-Metal	60 - 61
Holesaws, Carbide Tipped	60
Hollow Punches	381
Hones, Cylinder	333
Hook Wrenches	507
Hook Wrenches, Adjustable	159
Hook-n-Loop Discs	169
Hooks & Picks, Engineers	385
Hooks, Cabin	747
Carabiner	755
Carbine	755
Coat	745
Hose Clamps	331
Clip Pliers	330 - 331
Clips	642
Hoses, Airline	194
Coolant	311
Hydraulic	442
Oxy-Propane	710
Water	194, 393
Welding	710
Hot Dip Coatings	646
Hub Spanners	349
Huntington Wheel Dressers	319
Hydraulic Hoses	442
Presses	329
Pullers	339, 343
Ram	329
Seal Repair Kits	337, 737
Hygrometers	250, 372

I

Ice Breaker	391
Identification Tapes	752
Identity Discs	734
Immersion Heater Spanners	549
Impact Drills, Electric	227
Sockets & Accessories	536 - 543
Wrenches, Air	219 - 221
Wrenches, Cordless	231
Indexable Milling Cutters	142 - 145, 147, 150 - 152, 154
Milling Inserts	144, 147, 150 - 151
Toolholder Spares	155
Indexing Units & Rotary Tables	295
Indicators, Digital	262
Injection Pump Pullers	349
Injector Removal Set	349
Injector Seat Cutter Set	349
Insect Killers	685
Inserts, Carbide Threading	149
Inspection Lamps	237, 335, 350, 732
Inspection Mirrors	382
Insulated Tools	418 - 421, 450, 473 - 474
Insulation Tapes	760
Internal Micrometers	266
Irons, Soldering	366 - 368

J

Jack Planes	600
Jackets, Workwear	798
Jacks, Bottle	336
Scissor	337
Transmission	338
Trolley	336 - 338
Jerry Cans	346, 436, 685
Jigsaw Blades	184 - 185
Jobber Drills	34, 36 - 44
Jump Leads	346
Junction Boxes, Electrical	236

K

KC3	86
Ken-Grip	508 - 509, 525
Kentucky Mops	671
Key Blanks, Safe	683
Cabinets	683
Rings	683
Steel	281
Wrench, Universal	549
Keyless Drill Chucks	206, 296
Keys, Chuck	297
Keys, Stopcock	549
Kick Stools	682
Kitchen Appliances	685
Kits, Body Repair	326 - 328
Knee Pads	392, 740, 791
Knife Blades	425, 428 - 429
Knives, Disposable	424
Filling	408
Hacking	409

Knives, Linoleum	409
Palette	409
Pocket	424
Precision	428 - 429
Putty	409
Shoe	409
Snap Off	425
Strapping & Carton	426 - 699
Trimming	426 - 427
Utility	427
Knurls & Knurling Toolholders	314
Kraft Paper	688

L

Ladders, Aluminium	735
Ladders, Step	735
Laminating Brushes	411
Lamps, Inspection	237, 335, 350, 732
Lapping Products	188, 229
Laptop Bags	561, 680
Latex Gloves	788
Lathe Carriers	309
Chuck Jaws	315, 318
Chuck Keys	315
Chucks	315
Lathes, Metalworking	222
Laundry Products	667
Laundry Trolleys	758
Lazy Tong Riveters	467
Leads Power Extension	236
Leads/Probes, Multimetre Test	370 - 371
Leak Detector Spray	655
Left Hand HSS Dies & Die Nuts	93
Lenses, Welding	712
Levels, Digital	262
Levels, Spirit	354
Lever Action Riveters	466
Pumps	437
Type Dial Test Indicators	247
Lifting Equipment	336 - 338, 735
Lifting Suction Cups	327
Lighting Products	730 - 733
Line Marking Paints	657
Line Pins	357
Linen Trolleys	758
Linoleum Knives	409
Liquid Measures	436
Litter Picker	670
Load Restraints	753
Lock Cylinders, Door	744
Lock Washers	631
Locking Tapes	422
Lockout & Tagout Systems	751
Long Arm Riveters	467
Loppers	388
Lo-Tac Tapes	699
Louvre Panels Storage Systems	276 - 277
Louvred Panel Bin Kits	277
Low Noise Tapes	696
Lubricants, Chain & Drive	651 - 652
Food Industry	658 - 659
General Purpose	651 - 653
Specialist	652
Wire rope	651
Lubricators, Airline	195

M

Machine Taps	108 - 112
Machine Vices	306 - 307
Mag-Drill Cutters	203
Magnetic Bases	263 - 265
Cable Guides	363
Chuck Blocks	444
Drilling Machines	202 - 203
Hammers	400
Holdfasts	444
Links	443
Pick-Up Tools	442 - 443
Strips	752
Trays	443, 579
Vee Blocks	443
Wing Covers	350
Magnets	444
Magnifiers, Bench	253
Eye Loupes	252 - 253, 382
Pocket/Hand	252
Mains Testers	363
Maintenance Drill Sets	35
Mallets	402 - 403
Mandrel	229
Markers, Ink	657
Metal	657
Paint	657

Marking Gauges	602
Masking Tapes	698
Masonry Drill Bits	62
Materials Handling	757 - 759
Mats, Door	670
Matting, Safety	740 - 741
Maxi Fuses	325
Measuring Jugs	436
Measuring Wheels, Road	423
Mechanical Pullers	341
Mechanical Stroke Counters	251
Mechanics Stethoscope	335
Mechanic's Tools	327, 331, 340, 348, 350, 520, 530 - 531, 649
Medical Dressings	762
Melting Pots	646
Memory Sticks	680
Metal Cleaners	650, 668
Metal Markers	657
Metalworking Lathes	222
Meters, Airflow	250, 372
Humidity	250, 369, 372
Thermometers	250, 372
Micrometer Heads	270
Setting Standards, External	267
Stands	267
Micrometers, Depth	270
External	267 - 268
External, Digital	262, 270
External, Interchangeable Anvils	269
External, Point	270
External, Wire	270
Internal	266
Internal, Digital	266 - 267
Microscopes	256
MIG Welders	706 - 708
MIG Wire	707, 709
Milled Tooth Hand Files	56
Milling & Drilling Machines	222
Cutter Sets	83
Cutters, Indexable	142 - 145, 147, 150 - 152, 154
Cutters, Multi-Tooth	203
Cutters, Throwaway	86
Inserts	144, 147, 150 - 151
Mini Clips	642
Mirrors, Inspection	382
Mirrors, Security	683
Mitre Blocks & Boxes	599
Mitre Saws, Electric	226
Mixers, Paint & Plaster	355
Mobile Tool Workshop	569
Mop Buckets	671, 673
Mops	670 - 671, 673
Morse Taper Arbors	161
Drill Sleeves	316
Extension Sockets	316
Mortice Gauges	602
Mould Release Sprays	656
Mounted Points	190 - 191, 202, 229
Multi-Angle Vices	368
Multi-Function Tools	451, 596
Multimeter Test Leads/Probes	370 - 371
Multimeters	250, 369 - 371
Multipliers, Torque	447
Multi-Tools & Engravers	226, 228
Multi-Tooth, Milling Cutters	203

N

Nail Pouches	556
Nail Punches	380
Needle Hand Files	54
Needle Scalars, Air	213
Nibbler & Shear Accessories	214
Nibblers & Shears, Air	214
Nibblers, Sheet Metal	553
Nippers, Diagonal Cutting	421, 454, 457
End Cutting	454, 457
Miniature	457
Nipples, Grease	442
Nitrile Gloves	786 - 787
Non-Sparking Safety Tools	475, 486 - 490
Notepads	680
Noticeboards	686
Nozzles, Welding	708
Number Punches	464
Nut Spinners	447
Nut Splitters	339
Nuts, Hexagon	630, 634
Nyloc	630
Rivet	639
Rivet Inserters	466
Nylon Faced Hammers	404 - 406

O

O Rings	648
O-Clip Pincers	455, 643
O-Clips	642 - 643
Office Accessories	682
Offset Handles, Square Drive	517, 521
Oil Absorbent Granules	728
Cans	438
Drainer	439
Drip Trays	439
Filter Removers	340, 507, 520, 531
Measures	436
Spill Control	716 - 719, 721 - 729
Oilers, Bottles	438
Oils, Multi Purpose	652 - 653
Oilstones	192 - 193, 559
Open Ended Spanners	229, 418, 491 - 493, 504 - 506
Optical Equipment	271, 661
Orbital Sanders, Air	216 - 217
Orbital Sanders, Electric	216
O-Ring Fasteners	632
Oven Cleaners	668
Overshoes	794
Oversleeves	794
Oxy-Propane Hoses	710

P

Packaging Materials	688, 692
Padlocks	748 - 751
Pads, Elbow Protection	791
Pads, Writing	680
Padsaws	430, 599
Paint & Plaster Mixers	355
Brushes	410 - 411
Kettles	413 - 414
Markers	657
Pads	413
Rollers	412 - 413
Trays	413
Paints, Cold Galvanising	653
Enamel	647
Floor	647
Radiator	647
Palette Knives	409
Pallet Trucks	759
Panel Beating Tools	326
Panic Bolts	743
Paper Towels & Wipes	677
Paper, Wrapping	688
Parallels, Granite	249
Parallels, Steel	273
Parts Storage	555, 569
Parts Washers	339
PCB Drills, Carbide	25
PCL	197, 199, 201
P-Clips	643
Pedestal Drills	223
Penetrating Fluids	651 - 653
Pens, Marker	657
Petrol Cans	346
Pick Axes	390, 407
Picks & Hooks, Engineers	385
Pick-Up Tools	384
Pick-Up Tools, Magnetic	442 - 443
Pillar Drills	223
Pilot Cases	680
Pin Chucks	385
Punches	351, 380 - 381
Spanners	493
Vices	385
Pincers, Carpenters	455
Pincers, O-Clip	455, 643
Pins, Clevis	633
Pins, Safety	762
Pipe Bending Tools	544
Clips	643
Crimpers	546
Cutters	544 - 545
Deburrers	545
Flaring Tools	546
Roller Stands	551
Vices	547
Wrenches	548 - 549
Piston Ring Compressors	332
Planers, Electric	226
Planes, Block	600
Jack	600
Smoothing	600
Planishing Hammers	402
Plaster & Paint Mixers	355
Plasterers Hawks	355
Tape	698

Plasterers Trowels	355
Plastering Tools	355
Plasters & Dressings, Medical	762
Plastic Faced Hammers	404 - 406
Pliers, Bent Nose	457
Circlip	350, 458 - 459
Combination	450 - 451
Crimping	358, 362
Diagonal Cutting	421, 454, 457
Electronics	455 - 457
End Cutting	454, 457
Fencing	390, 455
Flat Nose	452 - 453
Flat Nose Miniature	457
Glow Plug	348, 452
Hose Clip	330 - 331
Insulated	418, 421, 450, 593
Linesmans	450 - 451
Locking	460 - 463
Long Nose	452 - 453, 457
Micro Nippers	457
Miniature	455 - 456
Oil Filter	340
Piston Ring	332
Revolving Punch	459
Sets	449
Sheet Metal	449, 451
Snipe Nose	421, 452 - 453, 457
Stainless Steel	456
Tile Cutting	415
Toggle	305
Water Pump	418, 448, 450 - 451
Wire Stripping	364 - 365, 421, 459
Wire Twisting	459
Plugs, Site	236
Plumb Bobs	357
Plunger Type, Dial Test Indicators	246
Pneumatic Fittings	196 - 199, 240 - 241
Pocket Knives	424
Pocket Magnifiers	252
Pockets, Document	680
Podger Spanners	491
Polishers, Air	216
Polishing & Finishing Kits	179
Bonnets	169, 234
Compounds	188 - 189
Mops	189
Rolls	186
Polo Shirts	796 - 797
Polypropylene Sacks	674, 689
Polythene Bags	689
Pop Rivets	633, 639
Portable Workbenches	279
Pouches, Nail	556 - 557
Power Extension Leads	236
Tool Chisels	239
Tool Tidy	567
Precision Knives	428 - 429
Precision Tool Sets	268
Presentation Accessories	686
Presses, Hydraulic	329
Pressure Gauges, Airline	194
Testers	546
Washers	225
Propane & Butane Gas Equipment	366 - 367
Protective Sleeving	694
Pro-Torq Pliers	421, 448 - 450, 452 - 454, 459
Pro-Torq Screwdrivers	468
Protractors, Bevel	257
Protractors, Digital	262
Pruning Shears	388
Pry Bars	351, 353
PTFE Tapes	646
Pull Studs	156
Pullers, Hydraulic	339, 343
Injection Pump	349
Mechanical	326, 341, 344
Ratcheting	735
Pulleys	755
Pumps, Coolant Sump	661
Grease	438 - 439
Lever	437
Oil & Fuel	437
Rotary	437
Syphon	437
Water	225
Punches, Centre	380
Hole	465, 546
Hollow	381
Nail	380
Pin	351, 380
Taper	381
Punners	391
Push-On Fasteners	631
Push/Pull Tapes	422
Putty Knives	409

Q

Q-Torq	445, 447
Quick Change, Toolposts & Toolholders	308 - 309
Quick Grip Clamps	433 - 434
Quick-Vices	222

R

Rack Clamps	280
Racking, Industrial	278
Radiator Enamel Paints	647
Radius Gauges	378
Rafters Squares	605
Rakes, Asphalt	391
Rakes, Garden	387
Ram, Hydraulic	329
Rasps, Hand Files	56
Ratchet Handles, Square Drive	516
Repair Kits	446, 512, 516, 521
Spanners	491, 495 - 497, 501
Wrenches, Square Drive	478, 510, 512, 516, 521 - 522
Rawhide Hammers	406
Reamers	88 - 89
Reference/Data Books	813
Refill Pads	680
Refractometers	271, 661
Refuse Sacks	396, 674
Regulators, Flow	241
Repair Links, Chain & Rope	754
Respirators, Disposable	769 - 771
Reusable Barrier Systems	761
Revolving Centres	317
Revolving Punch Pliers	459
Riddle, Wire Mesh	388
Riffler, Diemakers Files	55
Rigger Boots	805
Rigger Gloves	780
Ring Spanners	418, 491, 501 - 502
Ripper Cutters	70, 74 - 75, 81 - 82, 85
Rivet Nut Inserters	466
Rivet Nuts	639
Riveters, Lazy Tong	467
Riveters, Long Arm	467
Riveting Tools	466 - 467
Rivets, Pop	633, 639
Road Measuring Wheels	423
Rods, Drain	550
Roller Cabinet Accessories	576
Cabinet Spares	574, 578, 581, 583
Cabinets	571 - 576, 578 - 583
Stands	551
Rollers, Paint	412 - 413
Rolling Workshop	569
Rope & Chain Fittings	754
Hooks	755
Repair Links	754
Ropes, Towing	347
Rotary Pumps	437
Rotary Tables & Indexing Units	295
Router Cutters	238
Rubber Hammers	405
Rule, Counter	375
Rules, Aluminium	375
Folding	605
Steel	374 - 375
Rust Preventatives	653, 697

S

Sack Ties	689
Sack Trucks	757 - 758
Sacks, Polypropylene	674, 689
Saddle Clamps	643
Safe Key Blanks	683
Safes, Security	683
Safety Boots	804 - 807
Eyeshields	772
Eyewear	712, 772 - 777
Footwear	804 - 807
Helmets	767
Matting	740 - 741
Pins	762
Signs	671
Sanders, Air	216 - 217
Electric	232
Orbital, Electric	216
Sand/Filter Bags	671
Sanding Bands	171, 229
Belts	170, 218, 233
Discs	168 - 169, 173, 179, 187, 233 - 234
Drum Holders	171, 229
Pads	166

Sanding Sheets	166 - 167
Sheets, Hook-n-Loop Backed	169
Sponges	167, 186
Sticks	170
Sash Clamps	433
Cord	753
Locks	744
Tools	411
Saw Blades, Circular, HSS	90, 235
Blades, Tile	58, 430
Drills	604
Horse	598
Sawing & Drilling Lubricant	101, 652
Saws, Air	214
Bow	388
Circular, Electric	226
Compass	599
Coping	58, 430, 599
Floorboard	598
Flush Cutting	599
Gents	599
Hand	598
Masonry	356, 598
Mitre, Electric	226
Pad	430, 599
Plasterboard	599
Pruning	388
Slitting	90
Tenon	598
Scaffolding Spanners	492
Scissor Jacks	337
Scissors	416 - 417
Scraper Blades	408
Scrapers	348, 391, 408, 601, 649
Cabinet	601
Engineers	385
Floor	391
Mechanics	348
Window	408
Screen Wash	649
Screen Wipes, Computer	681
Screw Drills, Carbide	31
Extractors	90
Fixings	628, 637
Gauges	378
Plug Gauges, Double Ended	270
Screwdriver Bit Handles	478
Bit Holders, Hex Drive	478, 481
Bits	478 - 484
Screwdrivers, Air	215
Cordless	227, 231
Hand	420, 468 - 479, 637
Impact	485
Insulated	420, 473 - 474, 593
Jewellers	475
Mechanics	472
Precision	476 - 477
Torque	445
Screws, Self Tapping	628
Socket Head Button	625 - 626, 629
Socket Head Cap	614 - 619, 627, 629
Socket Head Countersunk	622 - 624, 627, 629
Socket Head Shoulder	627
Socket Set	620 - 621
Wood	628, 637
Scribers	384
Scroll Saws, Electric	233
Scutch Hammers	400
SDS-Plus Hammer Drill Bits	63
Seal Puller Tools	350
Seal Repair Kits, Hydraulic	337, 737
Sealant Guns	646
Sealants	646
Seam Rollers	409
Secateurs	388
Secondary Containment Storage	716 - 719, 728 - 729
Security Mirrors	683
Self Tapping Screws	628
Separators, Ball Joint	342
Separators, Chain	549
Service Cases	569
Service, Trolleys	758
Sets, Centre Drill	26
Shackles, Dee	755
Shank Adaptors	157, 161, 297
Shavehooks	409
Shear & Nibbler Accessories	214
Shears & Nibblers, Air	214
Shears & Snips	552 - 553
Shears, Bench	314
Electronic	455
Grass	388
Pruning	388
Sheet & Tube Drills	20
Sheet Metal Nibblers	553
Sheet Metal Tools	402, 553
Shelves, Storage	278

Shim, Steel	281
Shoe Knives	409
Shoes, Safety	807
Shoulder Screws, Socket Head	627
Shovels	389
Shovels, Hand	670
Shovels, Snow	391
Side Plates, Wire Wheels	242
Sidelock Adaptors	157
Signs, Safety	671
Silicone Sealants	646
Site Lights	237
Skin Conditioning Creams	666
Sledge Hammers	401
Sleeves, Cut resistant	788
Sleeving, Protective	694
Sliding Bevels	605
Slings, Lifting	735
Slip Gauges	271
Slitting Saws	90
Slogging Spanners	491 - 492
Slot Drills	66 - 69, 71 - 74, 76 - 80, 82, 84 - 86, 155
Smoking Bins	674
Smoothing Planes	600
Snap Off Knives & Blades	425
Snipe Nose Pliers	421, 452 - 453, 457
Snips & Shears	552 - 553
Snips, Metal Cutting	552 - 553
Snow Shovels	391
Soap & Hand Cleanser Dispensers	664 - 665
Soaps, Hand	664 - 666
Socket Accessories, Go-Through	495
Accessories, Hand	516
Button Head, Screws	625 - 626, 629
Head, Cap Screws	614 - 619, 627, 629
Head, Shoulder Screws	627
Rails & Clips	523
Screws, Button Head	625 - 626, 629
Screws, Cap Head	614 - 619, 627, 629
Screws, Countersunk Head	622 - 624, 627, 629
Set Cases	528 - 530, 532 - 534
Set Screws	620 - 621
Sets	506, 509, 517, 524 - 535
Sockets & Accessories, Square Drive	483, 506, 508, 510 - 522
Sockets & Accessories, Square Drive, Insulated	418 - 419
Sockets, Go-Through	495
Sockets, Impact, Square Drive	536 - 543
Soldering Tools	366 - 368
Solid Centres	317
Solvents	650
Spades, Garden	386
Spanners, Adjustable	322 - 324
Adjustable, Insulated	418
Black	491
Box	494
C-Hook	159, 492, 507
Combination	494 - 500
Flared Nut Ring	503
Hub	349
Ignition/Miniature	506 - 507
Immersion Heater	549
Obstruction	502
Open Ended	229, 418, 491 - 493, 504 - 506
Pin	493
Podger	491
Ratchet	491, 495 - 497, 501
Ring	418, 491, 501 - 502
Scaffolding	492
Slogging	491 - 492
Torx Ring	500
Spark Resistant Safety Tools	475, 486 - 490
Spectacles, Safety	772 - 775
Speed Braces, Square Drive	513 - 517
Clamps	434, 462
Ratchets, Air	219
Wrenches	548
Spill Control, Oil & Chemical	716 - 719, 721 - 729
Spinner Handles, Square Drive	510, 513
Spiral Flute Taps	93, 95, 97 - 102, 108 - 112
Spiral Point Taps	93, 95, 97 - 102, 108 - 112
Spire Clips	631
Spirit Levels	354
Splicing Kit, Wire	325
Splitters, Nut	339
Sponges, Cleaning	415, 669, 673
Spot Drilling Inserts, Indexable	155
Spot Weld Removers	326
Spotting Drills	24
Spotting Drills, Carbide	24
Spray Cleaners, Foam	650
Dispensers	438
Grease, Copper	654
Gun Accessories	200
Guns, Air	200
Sprayers, Garden	392, 394 - 395
Spring Calipers	377
Compressors	332

Spring Dividers	377
Squares, Engineers	270, 376
Granite	249
Rafters	605
Toolmakers	376
Try	605
Squeegees	671
Stales, Mop & Broom	670 - 671
Stands, Micrometer	267
Staple Extractors	692
Staplers	692
STD Cutting Compounds	101, 652
STD Cutting Fluids	101, 652
Steel Balls	640
Dowel Pins	633, 640 - 641
Gauge Plate	281
Parallels	273
Rules	374 - 375
Shim	281
Wool	186
Stencils	465
Step Ladders	735
Stethoscope, Mechanics	335
Stikit	168
Stillson Pipe Wrenches	548
Stockinette	669
Stopcock Keys	549
Stopwatches	251
Storage Bins	276 - 277
Storage CNC Tools	156
Storage, Secondary Containment	716 - 719, 728 - 729
Storage Shelves	278
Straight Edges, Granite	249
Straight Flute Taps	92 - 104, 110
Strap Wrenches	340, 507, 549
Strapping & Carton Cutters	426, 699
Materials & Tools	690 - 691
Tools	690
Straps, Cargo	753
Stretchwrap Film	688
Stretchwrap Machines	688
Strip, Feeler	379
Stripper Bolts	627
Stroke Counters, Mechanical	251
Stub Drills	25, 29 - 31
Stud Extractors, Square Drive	520
Studding, Connectors	638
High Tensile	638
Mild Steel	638
Stainless Steel	638
Suction Pads	327
Suds Brushes	411
Sump Pumps	661
Super Glues	647
Support Props, Plastering	355
Surface Cleaners	649, 667 - 668
Conditioning Abrasives	173, 179, 186 - 189, 229
Forming Tools	601
Gauges	384
Plates, Granite	249
Sweatshirts	796 - 797
Swedish Pipe Wrenches	548
Sweeping Mops	670
Swiss+Burr	134 - 137
Swiss+Tech	40 - 42
Swivel End Socket Wrenches	507
Handles, 1/2" Drive	517
Handles, 3/8" Drive	512
Handles, Square Drive	510, 512, 517, 521
Syphon Pumps	437

T

Tabbies, Key Rings	683
Tachometers	251, 372
Tackers, Hand	692
Tacklifters	603
Tagout & Lockout Systems	751
Tags & Tickets	752
Tally Counters, Hand	251
Tap & Die Sets	105
& Drill Sets, HSS	35, 38, 95
Wrenches	383
Tape Dispensers	695
Tape Measures	422 - 423
Taper Punches	381
Taper Shank Drills	48 - 49
Tapes, Adhesive	695, 697
Aluminium foil	697
Builders PVC	697
Double Sided	698 - 699
Hazard Marking	752
Identification	752
Industrial	695 - 699
Insulation	760
Locking	422

Tapes, Lo-Tac	699
Low Noise	696
Masking	698
Packaging	695 - 696, 699
Plasterboard	698
PTFE	646
Push/Pull	422
Waterproof	697
Tapping & Drilling Lubricant	101, 652
Adaptors	162 - 163
Head Sets	161
Taps, Drum	437
Fluteless	93, 97, 104, 112
Hand	92 - 104
Hand, Left Hand	93
Machine	108 - 112
Spiral Flute	93, 95, 97 - 102, 108 - 112
Spiral Point	93, 95, 97 - 102, 108 - 112
Straight Flute	92 - 104, 110
Tarpaulins	756
Tea Towels	669
Telephone Wipes	681
Telescopic Gauges	376
Telescopic Plastic Tubes	692
Terminals, Electrical	358 - 359
Terry Clips	643
Test Leads, Probes	370 - 371
T-Handles, Square Drive	510, 513, 517, 521 - 522
Thermometers	250, 372
Thickness Gauges	257
Thor	402 - 406
Thread Repair Inserts	636
Repair Kits	636
Restoring Files	19, 97
Threaded Bar, High Tensile	638
Mild Steel	638
Stainless Steel	638
Threading Heads	547
Inserts, Carbide	149
Sets	103, 105 - 106
Toolholders	148 - 149
Tickets & Tags	752
Ties, Sack	689
TIG Accessories	705
TIG Welders	702, 704
Tile & Glass Drills	62
Cutting Machines	227, 415
Cutting Pliers	415
Saw Blades	58, 430
Saws	430
Spacers	415
Timing Lights	345
Tinsnips	552
Tips, Soldering	366 - 368
Toggle Clamp Spares	304
Clamps	299 - 305
Pliers	305
Toilet Cleaners	668
Roll Dispensers	676 - 677
Rolls & Tissues	676
Tool Arrest Products	597
Bags	560 - 561
Belts	556 - 557
Blocks	156
Boxes	567 - 570
Cabinet Spares	574, 578, 581, 583
Cabinets	571 - 576, 578 - 583
Cases	561 - 567, 606, 609, 617
Chest Spares	578, 583
Chests	567 - 568, 571, 575, 577 - 580, 582 - 583
Control, Drawers & Inserts	584 - 585
Holsters	556 - 558
Kits	421, 567, 586 - 595, 604
Pouches	556 - 558
Rolls	559
Steel	281
Tethering	597
Trolleys	582
Toolbits, HSS & Cobalt	113
Toolholder Spares	120 - 133, 148, 150 - 152, 154
Toolholders, Indexable	120 - 129, 155
Knurling	314
Threading	148 - 149
Turning Spares	155
Toolmakers Clamps	385
Square	376
Vices	306 - 307
Toolposts & Toolholders, Quick Change	308 - 309
Torches, Battery	335, 730 - 733
Torque Drivers	445
End Fittings	446
Handles	445
Multipliers	447
Testers	447
Wrenches	445 - 447
Torx Keys	129, 132 - 133, 148, 150 - 152, 154, 611
Torx Ring Spanners	500

Towels & Wipes, Paper	677
Towing Ropes	347
Trainers, Safety	807
Tramp Oil Skimmers	661
Transmission Jacks	338
Trays, Magnetic	443, 579
Oil Drip	439
Paint	413
Trigger Spray Dispensers	438
Trim Pin Removers	326
Trimmers	692
Trimming Knives & Blades	426 - 427
Tripod Lights	237
Trolley Jacks	336 - 338
Trolleys, Gas Cylinder	710
Laundry	758
Service	758
Tool	582
Trowels, Adhesive	355
Builders	356
Plasterers	355
Trucks, Sack	757 - 758
Try Squares	605
T-Shirts	797
T-Slot Clamping Sets	282 - 283
T-Slot Cutters	64
Tube Cutters	544
Tubs, Multi Purpose	357, 414, 671
Turning Toolholders	120 - 129, 155
Turning Tools, Butt Welded	18
Tweezers, Engineers	375
Tweezers, Insulated	418
Tyre Tools	201, 347

U

Universal Joints, Square Drive	516
Universal Key Wrench	549
USB Flash Drives	680
USB Memory Sticks	680

V

Vacuum Cleaners	233
Lifters	327
Testers	331
Valve Tools	332
Vee Blocks, Cast Iron	272
Vee Blocks, Granite	249
Venting Drills	25
Vernier Calipers	259
Vice & Workbench	279
Vice Jaws	306, 551
Vices, Drill Press	306 - 307
Engineers	310
Machine	306 - 307
Multi-Angle	368
Multi-Purpose	310
Pin	385
Pipe	547
Quick Type	222
Toolmakers	306 - 307
Workshop	310
Visitors Coats	794
Visors, Face	766 - 767, 777
Voltage Detectors	364, 370

W

Wall Clocks	684
Wall Plugs	628, 637
Warning Triangle	347
Washers, Brass	634
BZP	631
Copper	631
Fibre	632
Lock	631
Steel	631
Washing Powders	667
Washing Up Liquids	668
Waste Bins	674
Waste Disposal Bags	396, 674
Watches, Stop	251
Water, De-ionised	651
Water Hose Fittings	393 - 395
Hoses	194, 393
Pumps, Submersible	225
Separators	195
Watering Cans	392
Waterproof Tapes	697
Waterproof Workwear	795
Weed Control Fabric	397
Weeding Tools	386
Weighing Scales	693

Welding & Cutting, Gas	708, 710
Accessories	703 - 708, 710
Arc Equipment	702
Chipping Hammers	400
Consumables	708 - 709
Curtains	711
Cutting Nozzles	708
Electrodes	703 - 704
Face Shields	712
Gas Bottles	706
Gas Regulators	706, 710
Gauntlets	713, 789
Helmets	712, 777
Hoses	710
Lenses	712
MIG Equipment	706 - 708
MIG Wire	707, 709
Nozzles	708
TIG Equipment	702, 704
Workwear	713, 767
Wellington Boots	805
Wet or Dry Paper	167
Wet Wipes, Hand	666, 675
Wheel Dressers, Diamond	319
Dressers, Huntington	319
Wrenches	347
Wheelbarrows	759
Wheels, Castor	738 - 739
Wheels, Wire	242 - 243
White Board Cleaner & Wipes	681, 686
Wiggler Sets	373
Window Scrapers	408
Window Washers	671
Windscreen De-Icer	649
Windscreen Repair Tools	327
Wing Covers, Magnetic	350
Wipes, Computer Screen	681
Industrial	675
Multi-Purpose	681
Telephone	681
White Board	681, 686
Workshop	666, 675, 677
Wire Brushes, Brass	242 - 243
Stainless	734
Steel	229
Wire Cutters	454
Gauges	378
MIG	707, 709
Rope Spray	651
Strippers	364 - 365, 421, 459
Twisting Pliers	459
Wheels	242 - 243
Wool	186
Wood Chisels	602 - 603
Wood Screws	628, 637
Woodruff Cutters, HSS	64
Work Benches & Cabinets	280
Holding Fixture Components	283 - 292
Lights	237, 733
Stands	596
Workbench & Vice	279
Workshop Vices	310
Workwear	713, 767, 795 - 803
Wrapping Paper	688
Wrecking Bars	353
Wrenches, Adjustable	322 - 324
Adjustable C-Hook	507
Basin	549
Chain	340, 507, 549
Combination	500
Crescent	502
Crowfoot	506
Heavy Duty Pipe	548
Hexagon	150 - 151, 606 - 610, 617, 621, 624
Ignition/Miniature	506 - 507
Oil Filter	340, 507, 520, 531
Pipe	548 - 549
Ratchet, Square Drive	478, 510, 512, 516, 521 - 522
Slogging	491 - 492
Speed	548
Stillson	548
Strap	340, 507, 549
Swivel End Socket	507
Tap	383
Torque	445 - 447
Torx	129, 132 - 133, 148, 150 - 152, 154, 611
Wheel	347
Writing Pads	680

Z

Z-Barrier	761
Zinc Paints	653
Zipcut Spot Weld Remover	326

GROUP 010 BUTT WELDED TOOLS



Page **18**

GROUP 016 DIE HEADS & CHASERS



Page **19**

GROUP 017 THREAD RESTORERS



Page **19**

GROUP 019 SHEET & TUBE DRILLS



Page **20**

GROUP 020 COUNTERSINKS



Page **20 - 23**

GROUP 021 COUNTERBORES



Page **24**

GROUP 025 DRILLS



Page **24 - 49**

GROUP 030 ENGINEER'S FILES

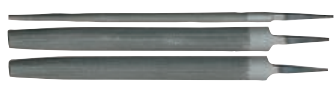

Page **50 - 53**

GROUP 031 PRECISION FILES



Page **54 - 55**

GROUP 032 MILLED FILES



Page **56**

GROUP 033 DIAMOND FILES



Page **57**

GROUP 040 HACKSAW & POWERSAW BLADES



Page **58 - 59**

GROUP 050 HOLESAWS



Page **60 - 61**

GROUP 055 MASONRY DRILLS



Page **62**

GROUP 057 SDS HAMMER DRILLS



Page **63**

GROUP 061 SHANK MILLING CUTTERS



Page **64 - 86**

GROUP 065 REAMERS



Page **88 - 89**

GROUP 072 SAW BLADES



Page **90**

GROUP 075 SCREW EXTRACTORS



Page **90**

GROUP 085 HSS TAPS & DIES



Page **91 - 106**

GROUP 085 PRODUCTION TAPS



Page **108 - 112**

GROUP 090 TOOLBITS & PARTING-OFF BLADES



Page **113**

GROUP 100 BRAZED TOOLS



Page **114 - 115**

GROUP 106 ISO TOOLHOLDERS



Page **116 - 133**

GROUP 109 DEBURRING TOOLS



Page **134 - 137**

GROUP 120 INSERTS - ISO TURNING & MILLING



Page **138 - 147**

GROUP 121 INDEXABLE THREADING



Page **148 - 149**

GROUP 139 INDEXABLE MILLING CUTTERS



Page **150 - 155**

GROUP 140 TOOLING ACCESSORIES



Page **156**

GROUP 144 SPINDLE NOSE TOOLING



Page **157 - 160**

GROUP 144 TAPPING CHUCKS & COLLETS



Page **161 - 163**



CUTTING TOOLS

Product Groups
005 - 184

Product Grading



Production

High performance industrial tooling designed for continuous use applications on machine tools where repeatability and long tool life are of critical importance.



Professional

Industrial tooling that has enhanced features and benefits demanded by craftsmen and professional users.



Industrial

Designed for regular use in industrial applications. Manufactured to stringent quality levels and international standards.



Workshop

Standard quality tooling for use by tradesmen and generally industrial use.



Maintenance

Products designed for general maintenance of machines, workshops, garages and some household applications.



Home Improver

DIY quality tooling. Designed for home use and light industrial applications.

Contents

Description	Group	Page
Brazed Tools	100	114 - 115
Butt Welded Tools	010	18
Counterbores	021	24
Countersinks	020	20 - 23
Deburring Tools	109	134 - 137
Die Heads	016	19
Drills - Blacksmith's (Reduced Shank)	025	35
- Blanks	025	43
- Centre	025	26 - 27
- Extra Length	025	47
- Long Series	025	45 - 46
- Masonry	055	62
- SDS Hammer	057	63
- Spotting	025	24
- Standard Length (Jobber)	025	32 - 44
- Stub	025	28 - 31
- Taper Shank	025	48 - 49
- Vent & Micro Precision	025	25
Drills - Sets	025	38 - 39
Files - Diamond Needle	033	57
Engineer's	030	50 - 53
Milled Tooth & Rasps	032	56
Needle	031	54
Precision	031	54
Riffler	031	55
Hacksaw & Powersaw Blades	040	58 - 59
Holesaws & Arbors	050	60 - 61
Indexable - Milling Cutters	139	150 - 155
- Threading	121	148 - 149
Inserts - ISO Milling	120	147
- ISO Turning	120	142 - 145
Reamers - Chucking	065	88
- Hand	065	89
- Taper Shank	065	89
Saw Blades	072	90
Screw Drills & Tap Extractors	075	90
Shank Milling Cutters	061	64 - 80
- Die & Mould	061	81 - 85
Sheet & Tube Drills	019	20
Spindle Nose Tooling Accessories	140	156
Spindle Nose Tooling	144	157 - 160
Tapping Chucks & Collets	144	162 - 163
Tapping Head Sets	144	161
Taps - Production	085	107 - 112
Taps & Dies - HSS	085	91 - 106
Thread Restoring Files	017	19
Throwaway Milling Cutters	062	86
Toolbits & Parting-off Blades	090	113
Toolholders - ISO Boring	106	130 - 133
- ISO External	106	120 - 129

Manufactured from top quality sintered steels. For use on a wide range of applications from roughing to finishing.
 Manufactured to **BS 1296 : Part 3 : 1978.**



CUTTING TOOLS

Light Turning & Facing

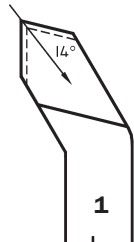

1
Right Hand

Shape No.1RH Rake & Clearance Angles	
Top Rake	14°
Front Clearance	6°
Approach Angle	-2°
Trail Angle	15°
Side Clearance	6°
Corner Radius	-



Shank (mm)	Overall Length	Order Code KEN-010	Price/1 TB
12 x 12	100	-0120K	1339.00
16 x 16	110	-0160K	1442.00

Knife or Side Cutting

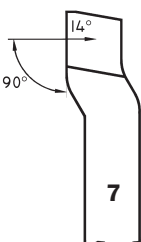

7
Right Hand

Shape No.7RH Rake & Clearance Angles	
Top Rake	14°
Front Clearance	6°
Approach Angle	-2°
Trail Angle	4 - 10°
Side Clearance	6°
Corner Radius	-



Shank (mm)	Overall Length	Order Code KEN-010	Price/1 TB
12 x 12	100	-1120K	1288.00
16 x 16	110	-1160K	1442.00

External Screw Cutting Right Hand



No Rake
 Also available for cutting left hand thread - No.13LH

13

No.13 RH
 (No.14 LH available on request)

Shape No.13RH Rake & Clearance Angles	
Top Rake	0°
Front Clearance	12°
Approach Angle	30°
Trail Angle	60°
Side Clearance	60°
Corner Radius	-



Shank (mm)	Overall Length	Order Code KEN-010	Price/1 TB
12 x 12	100	-2120K	1386.00
16 x 16	110	-2160K	1836.00

Parting Off



16
Right Hand

Shape No.16RH Rake & Clearance Angles	
Top Rake	5°
Front Clearance	6°
Approach Angle	90°
Trail Angle	0°
Side Clearance	1-2°
Corner Radius	-



Shank (mm)	Overall Length	Order Code KEN-010	Price/1 TB
12 x 12	100	-3120K	1339.00
16 x 16	110	-3160K	1339.00
20 x 20	125	-3200K	2266.00

Right Angle Recessing

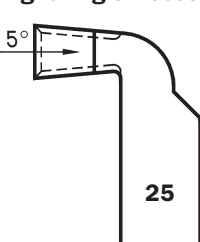

25
Right Hand

Shape No.25RH Rake & Clearance Angles	
Top Rake	5°
Front Clearance	6°
Approach Angle	0°
Trail Angle	2°
Side Clearance	3°
Corner Radius	-



Shank (mm)	Overall Length	Order Code KEN-010	Price/1 TB
16 x 16	110	-6160K	1854.00

Facing



19
Right Hand

Shape No.19RH Rake & Clearance Angles	
Top Rake	14°
Front Clearance	6°
Approach Angle	-30°
Trail Angle	15°
Side Clearance	6°
Corner Radius	3 - 8°



Shank (mm)	Overall Length	Order Code KEN-010	Price/1 TB
12 x 12	100	-5120K	1386.00
16 x 16	110	-5160K	1839.00

Internal Screw Cutting Tools

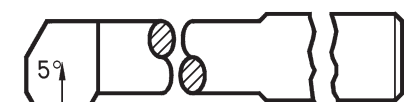

50A

Right Hand

Shape No. 50A Rake & Clearance Angles	
Top Rake	5°
Front Clearance	6°
Approach Angle	0°
Trail Angle	1°
Side Clearance	1°
Corner Radius	-

Shank (mm)	Overall Length	Order Code KEN-010	Price/1 TB
20 x 12	160	-8620K	2936.00



Boring Tools & Through Boring Tools

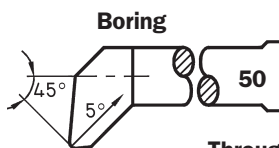

Through Boring

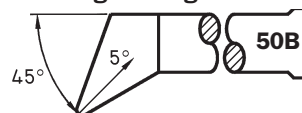

Right Hand

Rake & Clearance Angles	Shape No. 50	Shape No. 50B
Top Rake	5°	5°
Front Clearance	6°	6°
Approach Angle	-1°	-45°
Trail Angle	4°	30°
Side Clearance	6°	6°
Corner Radius	-3°	-6°
Cutting Angle	30°	90°

Shank (mm)	Overall Length	Order Code	KEN-010 No.50	Price/1 TB
12 x 12	160	-8120K	-	2936.00
16 x 16	200	-8160K	-9020K	3193.00





Die Heads

Coventry Die Heads produce clean and smooth threads for economy on short to medium production runs. The ease and simplicity in setting allows for minimum downtime when changing threads.

Coventry Dieheads are suitable for a wide variety of machines:

- Capstan and Turret Lathes.
- CNC or Automatic Screwing.
- Multi Spindle Automatics.
- Drilling Machines.

WS Style Coventry Die Heads

Robust and reliable. Can be used on a variety of manual or automatic* machines. Can be supplied with any other straight or tapered shank. Takes standard Coventry type chasers.

Repair parts readily available.
*Supplied with spring band closer.
Set for single cut only.



Model	Capacity	Body Diameter	Shank Diameter	Order Code CTL-016	Price/1 TB
WS6	1/4" (6mm)	1 1/2"	5/8"	-0006A	36050.00
WS12	1/2" (12mm)	2 1/2"	1"	-0012A	40170.00
WS20	3/4" (20mm)	3 7/16"	1 1/2"	-0020A	51500.00

HSS Coventry Type Chaser Dies

Cutting takes place only on the throat and the first full tooth; the remaining threads are above centre height and act as a nut, ensuring accurate pitch. Ideal for batch work or continuous production of threaded steel bar. Coventry dies are not interchangeable. An original set of new dies must always be used together. When taken from the diehead the set of dies should be retained in its box until required again.

Throat Angles

20° for general work and soft steels - supplied as standard.
33° 'B' type for cutting brass, available on request.

Grinding Dies

Only two angles are ground on Coventry dies, the throat angle and the rake angle and in the particular case of Holozone dies only the throat angle is ground. All dies in a set must be ground on the throat at the same time and since they cannot be accurately ground by hand, a die grinding fixture must be used.

Marking & Materials

Each die is marked with: diameter, pitch, type of die and gauge number. Non-standard or special dies are marked with an SD number which should be quoted when re-ordering. When a set of dies has been re-ground several times by grinding the throat angle, the height of the cutting edge rises above centre. This condition must be rectified by grinding the rake angle until the die height is correct according to the number shown on the die.



HSS

ISO Metric: Throat Angle S20

Size x Pitch	Diehead Size	Weight each	Order Code CTL-015	Price/1 TB
4 x 0.70	6mm	22g	-1015Q	5150.00
	12mm	59g	-1019V	5408.00
5 x 0.80	12mm	58g	-1024N	5408.00
	12mm	59g	-1030F	5408.00
	20mm	160g	-1031G	6695.00
8 x 1.25	12mm	55g	-1041S	5408.00
	20mm	150g	-1043V	6695.00
	12mm	52g	-1048A	5408.00
10 x 1.50	20mm	150g	-1050C	6695.00

Size x Pitch	Diehead Size	Weight each	Order Code CTL-015	Price/1 TB
12 x 1.75	12mm	50g	-1054G	5408.00
	20mm	147g	-1056J	6695.00
14 x 2.00	20mm	145g	-1061P	6695.00
	20mm	130g	-1075E	6695.00
20 x 2.50	25mm	210g	-1077G	7725.00
	32mm	355g	-1079J	12875.00
24 x 3.00	25mm	205g	-1085Q	7725.00
	32mm	320g	-1086R	12875.00
30 x 3.50	32mm	400g	-1091X	12875.00

SHERWOOD **Thread Restoring Files**

Restore internal and external threads by filing, where the use of taps and dies are impractical. The restorer file overlaps several good threads and files the damaged ones. Restore right and left hand, internal and external threads. Long lasting, fast cutting teeth. Thread restoring files are available in ISO, Whit/BSF, UNF/UNC and BSP thread types.

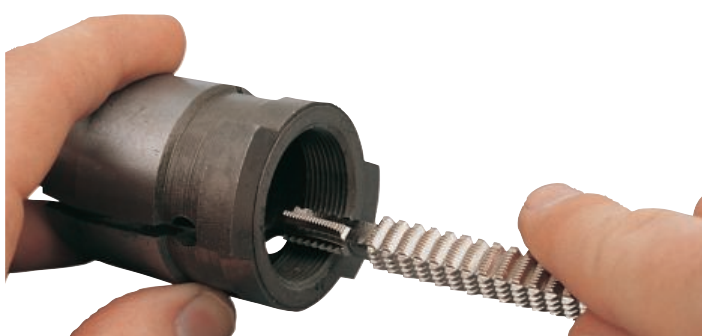

Thread Type	Range	Weight each	Order Code SHR-017	Price/1 TB
ISO	.80 to 3mm	133g	-9020C	979.00
Whit/BSF	10 tpi to 24 tpi	132g	-9001A	979.00
UNF/UNC	11 tpi to 24 tpi	130g	-9010B	979.00
BSP	11 tpi to 28 tpi	127g	-9030D	979.00

PRODUCTS ARE ONLY AVAILABLE VIA YOUR DISTRIBUTOR



HSS Multi-Diameter Step Drills

Produce good quality holes in a wide variety of materials, using either a bench drill or light pedestal drilling machine. Each tool cuts parallel holes in a range of specific sizes. For material up to 1/8" (3mm) thick.

HSS

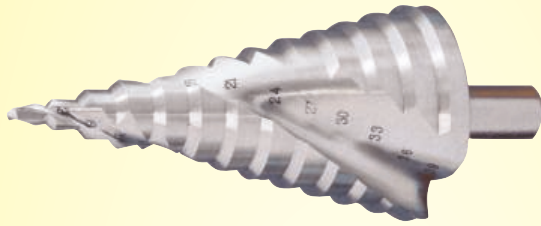

Size	Range	Number of Steps	Weight each	Order Code	Price/1 TB
0/5	4 - 12mm	5	30g	-0500K	957.00
0/9	4 - 12mm	9	30g	-0509K	1067.00
1	4 - 20mm	9	70g	-0510K	1394.00
2	4 - 30mm	11	200g	-0520K	2295.00
3	6 - 38mm	12	299g	-0530K	3553.00
5	4 - 39mm	14	320g	-0560K	3826.00
9	6 - 37mm	12	310g	-0600K	3416.00

HSS Sheet Metal Step Drill Set

HSS

Three piece stepped cone drill set manufactured from high speed steel, resulting in long tool life and extra durability. Each step produces specific sized, parallel holes, with the maximum material thickness being determined by the length of step. The drills are capable of producing or enlarging holes in sheet metals without the need for centre punch or pilot holes, and are designed for use with power tools or pedestal drilling machines for an extensive range of industrial applications.

Sizes include:

- 4 - 12mm (9 step, 6mm shank),
- 4 - 20mm (9 step, 8mm shank)
- and 4 - 30mm (14 step, 10mm shank).



3
PIECES

Number of Pieces	Range	Weight	Order Code	Price/1 TB
3	4 - 30mm	275g	-0260K	5192.00

HSS Taper Sheet & Tube Drills

HSS

For producing clean holes in sheet metal and other thin walled materials. Efficient cutting geometry, no pre-drilled pilot hole and the diameter of the finished hole is infinitely variable within the range of each drill, according to depth of feed.

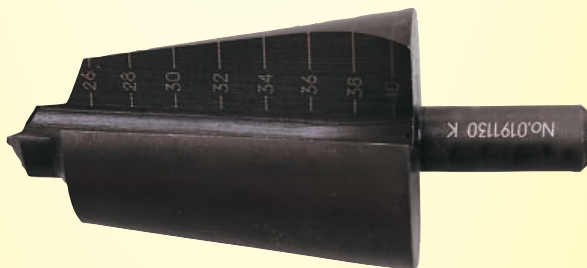

Range	Shank Diameter	Overall Length	Weight each	Order Code	Price/1 TB
3 - 14mm	6	57	30g	-1100K	747.00
8 - 20mm	8	66	60g	-1110K	977.00
16 - 30mm	9	74	140g	-1120K	1850.00
26 - 40mm	9	85	300g	-1130K	4329.00



HSS-E Co 5% Countersinks Single Hole



Manufactured from M35 HSS and used for the deburring and chamfering of most metals and plastics. Straight shank. Manufactured to BS328 : Part 5 : 1983. Inclusive angle 90°.

HSS-Co 5%



Cutting Range	Shank Diameter	Overall Length	Weight each	Order Code	Price/1 TB
2 - 5mm	6	32.0	15g	-2090K	957.00
5 - 10mm	8	30.5	25g	-2100K	1092.00
10 - 15mm	10	37.5	25g	-2150K	1421.00
15 - 20mm	12	48.0	110g	-2200K	2514.00
20 - 25mm	15	56.5	225g	-2250K	3525.00



HSS-E Co 5% Countersinks Single Hole



Manufactured from HSS-E cobalt for deburring and chamfering. Straight shank.

HSS-Co 5%

Manufactured to BS328 : Part 5 : 1983. Inclusive angle 90°.



Cutting Range	Shank Diameter	Overall Length	Weight each	Order Code	Price/1 TB
2 - 5mm	6	32.0	15g	-2090K	529.00
5 - 10mm	8	30.5	25g	-2100K	711.00
10 - 15mm	10	37.5	25g	-2150K	1096.00
15 - 20mm	12	48.0	110g	-2200K	2481.00
20 - 25mm	15	56.5	225g	-2250K	2929.00
25 - 30mm	15	55.0	315g	-2300K	4635.00

HSS Single Flute Countersinks

HSS

A quality range of single flute countersinking bits available in nine individual sizes and as a five piece set for use in the deburring and chamfering of most metals and plastics. Manufactured from high speed steel for durability and performance. Inclusive angle 90°.

NEW

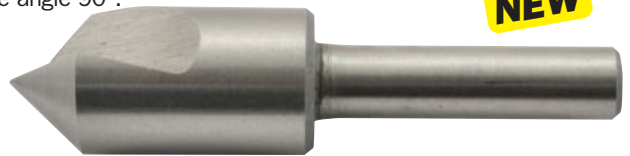

Size	Shank Diameter	Overall Length	Weight each	Order Code	Price/1 TB
3/16"	3/16"	1 3/8"		-9140K	308.00
1/4"	1/4"	1 1/2"		-9150K	366.00
5/16"	1/4"	2"		-9160K	411.00
3/8"	1/4"	2"		-9170K	438.00
1/2"	1/4"	2"		-9180K	490.00
5/8"	1/2"	2 1/4"		-9190K	773.00
3/4"	1/2"	2 3/4"		-9200K	876.00
7/8"	1/2"	2 3/4"		-9210K	1442.00
1"	1/2"	2 3/4"		-9220K	1545.00
5 Piece Set: 1/4", 3/8", 1/2", 3/4" & 1"				-9250K	2575.00

HSS-Co 5% Countersink Set

HSS-Co 5%

6 Piece Set
Straight shank, ground flute 90° angle. Sizes: 2 - 5mm, 5 - 10mm, 10 - 15mm, 15 - 20mm, 20 - 25mm and 25 - 30mm.

6
PIECES



Number of Pieces	Shank Style	Weight each	Order Code	Price/1 TB
6	Straight	1.2kg	-9020B	8239.00



HSS-Co 5% 3 Flute Piloted Countersinks

For the production of high precision concentrically centred countersinks in most metals where pilot holes have been pre-drilled.

Shank diameter: $\frac{3}{16}$ ".



Product Number	Diameter	Inc. Angle	Body Dia.	Overall Length	Order Code SHR-020	Price/1 TB
5802	$\frac{3}{32}$ "	100°	$\frac{3}{16}$ "	2 $\frac{1}{2}$ "	-5050D	675.00
5803	$\frac{3}{32}$ "	120°	$\frac{3}{16}$ "	2 $\frac{1}{2}$ "	-5054H	655.00
5810	$\frac{1}{8}$ "	100°	$\frac{1}{4}$ "	2 $\frac{1}{2}$ "	-5051E	660.00
5812	$\frac{1}{8}$ "	120°	$\frac{1}{4}$ "	2 $\frac{1}{2}$ "	-5055J	660.00
5821	$\frac{5}{32}$ "	100°	$\frac{5}{16}$ "	2 $\frac{1}{2}$ "	-5052F	689.00
5831	$\frac{3}{16}$ "	100°	$\frac{3}{8}$ "	2 $\frac{1}{2}$ "	-5053G	721.00
5832	$\frac{3}{16}$ "	120°	$\frac{3}{8}$ "	2 $\frac{1}{2}$ "	-5056K	773.00

HSS-Co 5% 3 Flute - Straight Shank

90° Heavy Duty

Manufactured from HSS-E cobalt steel for deburring and chamfering of most metals and plastics.

Manufactured to **BS328 : Part 5 : 1983.**

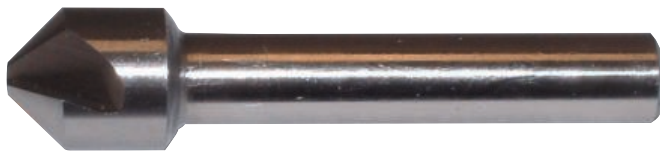

Cutting Diameter	Shank Diameter	Order Code SHR-020	Price/1 TB
8.0mm	8mm	-0790K	535.00
10.0mm	8mm	-0890K	681.00
12.5mm	8mm	-0990K	832.00
16.0mm	10mm	-1090K	832.00
20.0mm	10mm	-1110K	832.00
25.0mm	10mm	-1130K	1029.00

HSS-Co 5% Multi Flute - Straight Shank

Rose Pattern

Inclusive angle 90°.

Overall length: 52mm.



Cutting Diameter	Shank Diameter	Order Code SHR-020	Price/1 TB
9.5mm	4.8mm	-2040K	512.00
12.7mm	4.8mm	-2060K	534.00
15.8mm	6.3mm	-2080K	737.00

HSS-Co 5% Multi Flute - Straight Shank

Heavy Duty

Inclusive angle 90°.

Overall length: 40mm.

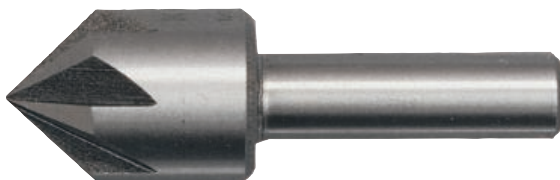

Cutting Diameter	Shank Diameter	Order Code SHR-020	Price/1 TB
12.7mm	6.3mm	-2000K	512.00

Inclined Angles for Countersunk Socket Head Screws			
Thread Series	Standard	Thread Size	Countersink Angle
Metric	BS EN ISO 10642	up to M20	90°
		over M20	60°
UNC/F	ANSI B 18.3	No.0 to 1"	82°
BSW/F	BS 2470	$\frac{1}{8}$ " TO 1"	90°
		8BA TO 0BA	90°

Diameter	Inc. Angle	Body Dia.	Overall Length	Order Code SHR-020	Price/1 TB
$\frac{3}{32}$ "	100°	.190	2 $\frac{1}{2}$ "	-5057L	655.00
$\frac{1}{8}$ "	100°	.252	2 $\frac{1}{2}$ "	-5058M	670.00
$\frac{5}{32}$ "	100°	.340	2 $\frac{1}{2}$ "	-5059N	670.00
$\frac{3}{16}$ "	100°	.405	2 $\frac{1}{2}$ "	-5060P	1025.00
$\frac{1}{4}$ "	100°	.530	2 $\frac{1}{2}$ "	-5061Q	1029.00

HSS-Co 5% 3 Flute - Taper Shank

90° inclusive angle.

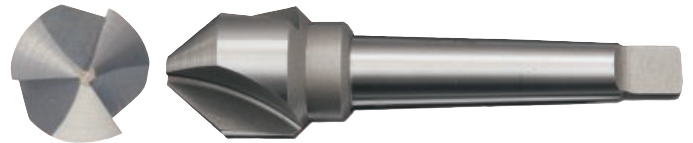

Cutting Diameter	Shank Diameter	Order Code SHR-020	Price/1 TB
16.0mm	1MT	-1550K	927.00
20.0mm	2MT	-1570K	1494.00
25.0mm	2MT	-1590K	1803.00
31.5mm	2MT	-1690K	2575.00
40.0mm	3MT	-1790K	4119.00
50.0mm	3MT	-1890K	5149.00
63.0mm	4MT	-1920K	6695.00



HSS-Co 5% Multi Flute - Straight Shank

Rose Pattern

Inclusive angle 90°.

Overall length: 52mm.



Cutting Diameter	Shank Diameter	Order Code KEN-020	Price/1 TB
9.5mm	4.8mm	-2040K	629.00
12.7mm	4.8mm	-2060K	738.00
15.8mm	6.3mm	-2080K	847.00

HSS-Co 5% Multi Flute - Straight Shank

Heavy Duty

Inclusive angle 90°.

Overall length: 40mm.

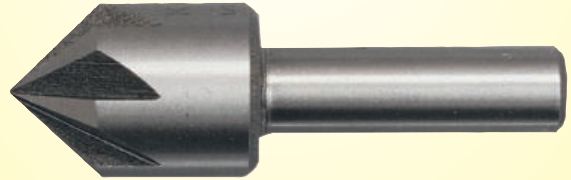

Cutting Diameter	Shank Diameter	Order Code KEN-020	Price/1 TB
12.7mm	6.3mm	-2000K	629.00



**HSS-Co 5% High Performance
Countersinks**

A chatter-free cutter giving an excellent burr-free finish. Capable of deburring and countersinking in one stroke with no 'back-off' of tool. Also free countersinking of aluminium with no secondary bulge. For special applications and exotic materials, a choice of hard coatings is available.



HSS-Co 5%

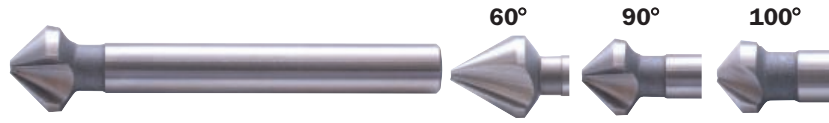
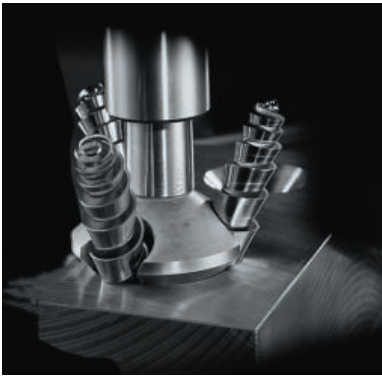

Cutting Diameter	Shank (mm)	Length (mm)	Weight each	Order Code SHR-020			Price/1 TB
				60° Countersink	90° Countersink	100° Countersink	
6.3mm	5	45		-5950K	-	-5450K	432.00
8.3mm	6	46	12g	-6000K	-5000K	-5500K	418.00
10.4mm	6	47	13g	-6050K	-5050K	-5550K	569.00
12.4mm	8	58	24g	-6100K	-5100K	-5600K	579.00
16.5mm	8	60	29g	-6150K	-5150K	-5650K	861.00
20.5mm	10	65	48g	-6200K	-5200K	-5700K	1315.00
25.0mm	10	69	70g	-6300K	-5250K	-5750K	1656.00

HSS-Co 5% Countersinks

3 Flute - Straight Shank

Manufactured from M35 HSS and used for the deburring and chamfering of most metals and plastics. Manufactured to **BS 328 : Part 5 : 1983**. Inclusive angle 82°.

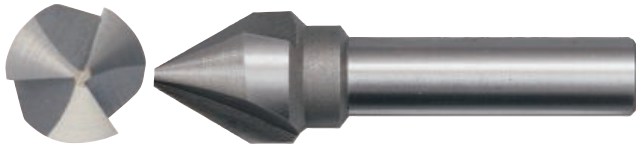

Cutting Diameter	Shank Diameter	Order Code SHR-020	Price/1 TB
8.5mm	8mm	-7090K	1190.00
10.0mm	8mm	-7100K	1298.00
12.5mm	8mm	-7120K	1579.00
16.0mm	10mm	-7160K	2218.00
20.0mm	10mm	-7200K	2759.00
25.0mm	10mm	-7250K	3786.00

HSS-Co 5% 90° Countersinks

For all ferrous and non-ferrous metals as well as for hard plastics. General purpose chamfering/deburring and countersinking tool. Bright finish, 3 flute, ground all over. **Made to DIN 335.**



Cutting Dia.	Shank (mm)	Length (mm)	Order Code SHR-020	Price/1 TB
6.0mm	5	45	-3060E	380.00
6.3mm	5	45	-3063J	380.00
8.3mm	6	50	-3083J	486.00
13.4mm	8	56	-3134Q	486.00
15.0mm	10	60	-3150G	539.00
19.0mm	10	63	-3190T	752.00
23.0mm	10	67	-3223G	966.00
30.0mm	12	71	-3230R	1547.00

5 Piece Set Contents:
6.30, 8.30, 13.40, 15.00 and 19.00mm.

NEW



Number of Pieces	Order Code SHR-020	Price/1 TB
5	-9260K	2318.00

HSS-Co 5%



**HSS-Co 5%
Countersinks**



HSS-Co 5%

3 Flute - Straight Shank

Manufactured from M35 HSS and used for the deburring and chamfering of most metals and plastics. Manufactured to **BS 328 : Part 5 : 1983**. Inclusive angle 90°.

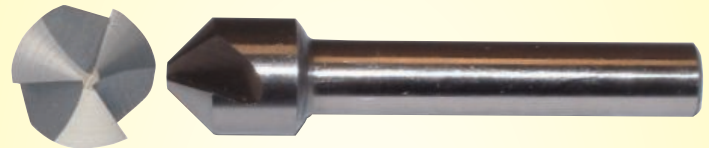

Cutting Diameter	Shank Diameter	Order Code KEN-020	Price/1 TB
8.0mm	8mm	-0790K	493.00
10.0mm	8mm	-0890K	563.00
12.5mm	8mm	-0990K	629.00
16.0mm	10mm	-1090K	738.00
20.0mm	10mm	-1110K	847.00
25.0mm	10mm	-1130K	1092.00

HSS-Co 5% Countersink Set 90°

HSS-Co 5%

6 Piece Set

Manufactured from M35 HSS and used for the deburring and chamfering of most metals and plastics. Straight shank, ground flute 90 angle. Manufactured to **BS328 : Part 5 : 1983**. Inclusive angle 90°. **Sizes:** 8, 10, 12.5, 16, 20 and 25mm.



**6
PIECES**

Number of Pieces	Weight	Order Code KEN-020	Price/1 TB
6	620g	-1160K	3605.00



HSS-Co 5% Countersink Set - 90°

6 Piece Set High Performance Multi Flute

Manufactured from HSS-E cobalt for deburring and chamfering. Straight shank, ground flute 90° angle. Manufactured to **BS328 : Part 5 : 1983**. Inclusive angle 90°.

Sizes: 6, 8, 10, 12.5, 16, 20 and 25mm.

HSS-Co 5%

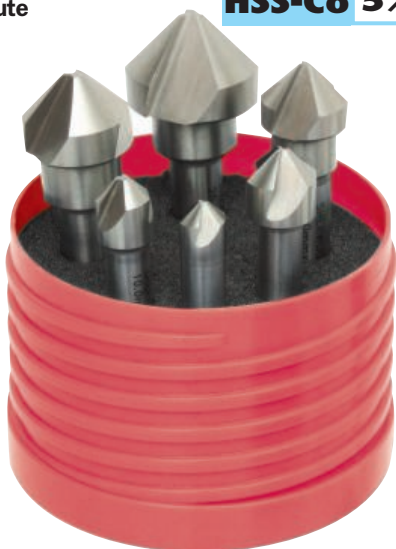

6 PIECES

Number of Pieces	Inclusive Angle	Order Code	Price/1 TB
6	90°	SHR-020 -9010A	3845.00

HSS-Co 5% TiN Coated Countersink Set - 90°

6 Piece Set High Performance Multi Flute Manufactured from HSS-E cobalt for deburring and chamfering. Straight shank, ground flute 90° angle. Manufactured to **BS328 : Part 5 : 1983**. Inclusive angle 90°.

Sizes: 6, 8, 10, 12.5, 16 and 20mm.

HSS-Co 5%

TiN



6 PIECES

Number of Pieces	Inclusive Angle	Order Code	Price/1 TB
6	90°	SHR-020 -8990Y	3029.00

HSS-Co 5% Countersink Set - 100°

5 Piece Set High Performance Multi Flute

Manufactured from HSS-E cobalt for deburring and chamfering. Straight shank, ground flute 100° angle. Manufactured to **BS328 : Part 5 : 1983**. Inclusive angle 100°.

Sizes: 6, 8, 10, 12.5 and 16mm.

HSS-Co 5%



5 PIECES

Number of Pieces	Inclusive Angle	Order Code	Price/1 TB
5	100°	SHR-020 -9130A	2812.00

HSS-Co 5% Countersink Set - 60°

5 Piece Set High Performance Multi Flute

Manufactured from HSS-E cobalt for deburring and chamfering. Straight shank, ground flute 60° angle. Manufactured to **BS328 : Part 5 : 1983**. Inclusive angle 60°.

Sizes: 6, 8, 10, 12.5 and 16mm.

HSS-Co 5%



5 PIECES

Number of Pieces	Inclusive Angle	Order Code	Price/1 TB
5	60°	SHR-020 -8150A	2704.00

KENNEDY Solid Carbide High Performance Premium Countersinks

CARBIDE

For the general purpose countersinking of tool steel, cast irons, high silicon aluminium, bronze and non-metallic materials such as resin fibre-glass and laminates. Available in three flute with eccentric relief and six flute with conventional relief. Manufactured to **USCTI Standards**.

3 Flute 90°



* Brazed steel shank

Cutting Diameter	Shank Diameter	Overall Length	Weight each	Order Code	Price/1 TB
1/4" (6.3mm)	1/4" (6.3mm)	2" (50mm)	30g	-0790K	1010.00
3/8" (9.5mm)	1/4" (6.3mm)*	2 13/16" (73mm)	40g	-0890K	1185.00
1/2" (12.7mm)	1/4" (6.3mm)*	2 7/8" (75mm)	50g	-0990K	1442.00
5/8" (16.0mm)	3/8" (9.5mm)*	3" (76mm)	90g	-1090K	1700.00
3/4" (19.0mm)	1/2" (12.7mm)*	3" (76mm)	130g	-1110K	2266.00

6 Flute 90°



* Brazed steel shank

Cutting Diameter	Shank Diameter	Overall Length	Weight each	Order Code	Price/1 TB
1/4" (6.3mm)	1/4" (6.3mm)	2" (50mm)	30g	-1790K	1029.00
3/8" (9.5mm)	1/4" (6.3mm)*	2 13/16" (73mm)	40g	-1890K	1339.00
1/2" (12.7mm)	1/4" (6.3mm)*	2 7/8" (75mm)	50g	-1990K	1803.00
5/8" (16.0mm)	3/8" (9.5mm)*	3" (76mm)	90g	-2090K	3193.00
3/4" (19.0mm)	1/2" (12.7mm)*	3" (76mm)	130g	-2110K	4223.00

PRODUCTS ARE ONLY AVAILABLE VIA YOUR DISTRIBUTOR



HSS Solid Counterbores

Spiral flute, 3 flute. Medium duty. Used for milling of pre-drilled holes to allow bolt or cap head screws to lie flush with the component surface.
Manufactured to **BS328: 5:1983**.

HSS

Plain Shank



Metric

Bolt Size	Pilot Dia.	Cutter Dia.	Overall Length	Weight each	Order Code SHR-021	Price/1 TB
3mm	3.4	6.0	65.0	10g	-3520K	915.00
4mm	4.3	8.0	65.0	10g	-3560K	985.00
5mm	5.3	10.0	70.0	10g	-3580K	985.00
6mm	6.4	11.0	76.0	20g	-3600K	1055.00
8mm	8.4	15.0	87.3	60g	-3620K	1564.00
10mm	10.5	18.0	89.0	70g	-3640K	1975.00
12mm	13.0	20.0	108.0	110g	-3660K	2218.00
16mm	17.0	26.0	125.0	225g	-3700K	3316.00

Plain Shank 7 Piece Set

Manufactured to **BS328 : 5 : 1983**.

Contents: M3, M4, M5, M6, M8, M10 and M12.



HSS



7 PIECES

Number of Pieces	Weight each	Order Code SHR-021	Price/1 TB
7	462g	-9010A	6953.00



HSS TiN Tipped Spotting Drills

Special drill for accurate and fast spotting on NC machines, jig drills and other capital-intensive boring machines. For countersinking and chamfering of tapping holes in one operation. Only suitable for shallow depth drilling.

HSS TiN-tip



Metric

Diameter (mm)	Flute Length	Overall Length	Weight per 5	Order Code SWT-125	Price/1 TB
4.00	12.0	46.0	20g	-5180A	478.00
5.00	14.0	62.0	40g	-5181A	585.00
6.00	16.0	66.0	65g	-5182A	600.00
8.00	21.0	79.0	135g	-5183A	797.00
10.00	24.0	89.0	265g	-5184A	903.00
12.00	30.0	102.0	434g	-5185A	1009.00
16.00	35.0	115.0	175g	-5187A	1327.00

90° Point 5 Piece Set

Contents: 4.00, 6.00, 8.00, 10.00 and 12.00



HSS TiN-tip

5 PIECES



Number of Pieces	Weight each	Order Code SWT-125	Price/1 TB
5	300g	-5190A	3182.00



HSS-E Spotting Drills

HSS-E

Special drill for accurate and fast spotting on NC machines, jig drills and other capital-intensive boring machines. For countersinking and chamfering of tapping holes in one operation. Only suitable for shallow depth drilling.

90° Ποινη - Σεριος X520



Metric

Diameter (mm)	Flute Length	Overall Length	Weight per 5	Order Code SHR-025	Price/1 TB
3.00	12.0	46.0	15g	-2528Y	150.00
4.00	12.0	46.0	20g	-2528Z	155.00
5.00	14.0	62.0	40g	-2529B	181.00
6.00	16.0	66.0	65g	-2529A	181.00
8.00	21.0	79.0	135g	-2530B	232.00
10.00	24.0	89.0	265g	-2531C	423.00
12.00	30.0	102.0	434g	-2532D	629.00
14.00	33.0	107.0	625g	-2532N	773.00
16.00	35.0	115.0	825g	-2533E	1391.00
20.00	40.0	131.0	1490g	-2534F	1906.00

90° Point 5 Piece Set

Contents: 4.00, 6.00, 8.00, 10.00 and 12.00mm.

HSS-E



5 PIECES

Number of Pieces	Order Code SHR-025	Price/1 TB
5	-9200K	1700.00

120° Ποινη - Σεριος X530

HSS-E



Metric

Diameter (mm)	Flute Length	Overall Length	Weight per 5	Order Code SHR-025	Price/1 TB
6.00	20.0	66.0	100g	-2535G	181.00
8.00	16.0	79.0	155g	-2536H	284.00
10.00	21.0	89.0	265g	-2537J	449.00
12.00	30.0	102.0	434g	-2538K	629.00
16.00	35.0	115.0	175g	-2539L	1597.00
20.00	40.0	131.0	298g	-2540M	2059.00

Carbide Spotting Drills

CARBIDE

Designed for close tolerance hole location.

Suitable for continuous production on aluminium, plastics, free cutting steels, cast iron, titanium and some aerospace materials. The stability of carbide makes the tool more rigid and less likely to deflect, maintaining a higher level of accuracy. Operators should note that continuous heavy shock loading may cause the tool to fail due to its brittleness.

90° Ποινη - Μετροιχ



Metric

Diameter (mm)	Flute Length	Overall Length	Weight per 5	Order Code SHR-158	Price/1 TB
4.00	10.0	40.0	40g	-8540K	399.00
6.00	16.0	50.0	100g	-8560K	846.00
8.00	23.0	60.0	155g	-8580K	1067.00
10.00	24.0	70.0	265g	-8600K	1706.00
12.00	25.0	70.0	434g	-8620K	2345.00
16.00	30.0	80.0	175g	-8660K	4547.00
20.00	35.0	100.0	298g	-8700K	7814.00



**HSS SCD
Stub Centring Drills**

Stub centering drills designed for sheet metal drilling and spot centering operations with a strong supporting web and a reduced chisel edge to help penetration.



HSS



135° Split Point - Series S510

Metric					Inch				
Diameter (mm)	Flute Length	Overall Length	Order Code SHR-025	Price/1 TB	Diameter (Inch)	Flute Length	Overall Length	Order Code SHR-025	Price/1 TB
2.0	14.0	43.0	-1396A	88.00	3/32"	9/16"	111/16"	-1400C	92.00
3.0	18.0	49.0	-1396C	67.00	1/8"	11/16"	115/16"	-1400F	78.00
4.0	18.0	55.0	-1396E	92.00	5/32"	11/16"	25/32"	-1400J	102.00
5.0	18.0	62.0	-1396G	119.00	3/16"	11/16"	27/16"	-1400M	129.00
6.0	18.0	70.0	-1396J	181.00	1/4"	3/4"	23/4"	-1400Q	205.00

HSS Straight Shank Quick Spiral, Extra Length Vent Drills

QUICK SPIRAL

Sherwood HSS quick spiral extra length Vent drills are designed for drilling the initial vent hole in aluminium tyre moulds, and are also used in the tyre industry for clean-out work post production where the high helix and extra reach are ideal for the efficient evacuation of waste rubber. Manufactured to works standard. 118° point angle.

HSS

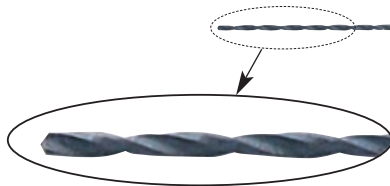

Metric				
Diameter (mm)	Flute Length	Overall Length	Order Code SHR-025	Price/1 TB
0.60	40.0	60.0	-2180D	361.00
0.70	40.0	76.0	-2180H	387.00
0.75	50.0	100.0	-2181P	411.00

Carbide Printed Circuit Board Drills

CARBIDE

Solid carbide printed circuit board drills. Suitable for drilling through printed circuit boards. Shank diameter 3.175mm, 38mm overall length. Manufactured to DIN 1899.

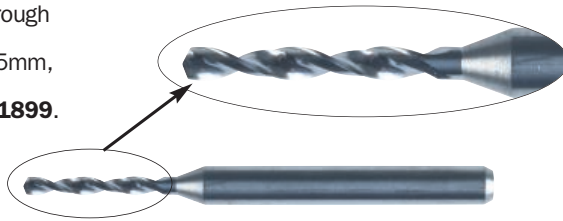

Metric Continued				
Diameter (mm)	Flute Length	Order Code SHR-158	Price/1 TB	
1.00	10.5	-3016R	319.00	
1.05	10.5	-3017S	319.00	
1.10	10.5	-3018T	319.00	
1.15	10.5	-3019V	319.00	
1.20	10.5	-3020W	319.00	
1.25	10.5	-3021X	319.00	
1.30	10.5	-3022Y	319.00	
1.35	10.5	-3023Z	319.00	
1.40	10.5	-3025A	319.00	
1.45	10.5	-3026B	319.00	
1.50	10.0	-3027C	319.00	

Metric			
Diameter (mm)	Flute Length	Order Code SHR-158	Price/1 TB
0.40	5.5	-3004D	319.00
0.45	5.5	-3005E	319.00
0.50	5.5	-3006F	319.00
0.55	7.0	-3007G	319.00
0.60	7.0	-3008H	319.00
0.65	7.0	-3009J	319.00
0.70	9.5	-3010K	319.00
0.75	9.5	-3011L	319.00
0.80	9.5	-3012M	319.00
0.85	9.5	-3013N	319.00
0.90	9.5	-3014P	319.00
0.95	9.5	-3015Q	319.00

Drilling Stack Height Limits for Drilling PCB Materials

Includes allowance for entry, materials thickness, penetration into backing material, and flute/swarf clearance.

Feed & Speed Guidelines for Drilling PCB Materials

Values listed are for your guidance. Drill parameters should be evaluated for different applications.

Drill Dia. (mm)	Suggested Drilling Stack Height Limits for Carbide PCB Drills		
	1 High	2 High	3 High
0.40	3.3	4.9	-
0.45	3.4	5.0	-
0.50	3.6	5.2	-
0.55	3.7	5.3	-
0.60	3.8	5.4	-
0.65	3.9	5.5	-
0.70	4.1	5.7	7.3
0.75	4.2	5.8	7.4
0.80	4.3	5.9	7.5
0.85	4.4	6.0	7.6
0.90	4.6	6.2	7.8
0.95	4.7	6.3	7.9
1.00	4.8	6.4	8.0
1.05	4.9	6.5	8.1
1.10	5.1	6.7	8.3
1.15	5.2	6.8	8.4
1.20	5.3	6.9	8.5
1.25	5.4	7.0	8.6
1.30	5.6	7.2	8.8
1.35	5.7	7.3	8.9
1.40	5.8	7.4	9.0
1.45	5.9	7.5	9.1
1.50	6.1	7.7	9.3



Drill Dia. (mm)	Cutting Speed 120m/min			Cutting Speed 150m/min			Cutting Speed 180m/min		
	Spindle RPM	Feed		Spindle RPM	Feed		Spindle RPM	Feed	
		mm/rev	m/min		mm/rev	m/min		mm/rev	m/min
0.40	95.000	0.024	2.3	119.000	0.024	2.9	143.000	0.024	3.4
0.45	85.000	0.027	2.3	106.000	0.027	2.9	127.000	0.027	3.4
0.50	76.000	0.030	2.3	95.000	0.030	2.9	115.000	0.030	3.4
0.55	70.000	0.033	2.3	87.500	0.033	2.9	405.000	0.033	3.4
0.60	64.000	0.036	2.3	80.000	0.036	2.9	95.000	0.036	3.4
0.65	59.500	0.039	2.3	74.000	0.039	2.9	88.500	0.039	3.4
0.70	55.000	0.042	2.3	68.000	0.042	2.9	82.000	0.042	3.4
0.75	51.500	0.045	2.3	64.000	0.045	2.9	77.000	0.045	3.4
0.80	48.000	0.048	2.3	60.000	0.048	2.9	72.000	0.048	3.4
0.85	45.000	0.051	2.3	56.500	0.051	2.9	68.000	0.051	3.4
0.90	42.000	0.054	2.3	53.000	0.054	2.9	64.000	0.054	3.4
0.95	40.000	0.057	2.3	50.500	0.057	2.9	60.500	0.057	3.4
1.00	38.000	0.060	2.3	48.000	0.060	2.9	57.000	0.060	3.4
1.05	36.500	0.063	2.3	45.500	0.063	2.9	54.500	0.063	3.4
1.10	35.000	0.066	2.3	43.000	0.066	2.9	52.000	0.066	3.4
1.15	33.500	0.069	2.3	41.500	0.069	2.9	50.000	0.069	3.4
1.20	32.000	0.072	2.3	40.000	0.072	2.9	48.000	0.072	3.4
1.25	30.500	0.075	2.3	38.500	0.075	2.9	46.000	0.075	3.4
1.30	29.000	0.078	2.3	37.000	0.078	2.9	44.000	0.078	3.4
1.35	28.000	0.081	2.3	35.500	0.081	2.9	42.500	0.081	3.4
1.40	27.000	0.084	2.3	34.000	0.084	2.9	41.000	0.084	3.4
1.45	26.000	0.087	2.3	33.000	0.087	2.9	39.500	0.087	3.4
1.50	25.000	0.090	2.3	32.000	0.090	2.9	38.000	0.090	3.4

PRODUCTS ARE ONLY AVAILABLE VIA YOUR DISTRIBUTOR

GROUP 025 CENTRE DRILLS

SWISS+TECH HSS TiN Tipped Centre Drills

Designed with spiral flutes and various lengths and forms to give high quality centre holes that suit most applications. TiN coating on working parts. 60° inclusive angle. Manufactured to **BS 328 : Part 2 : 1986, DIN 333A, ISO 866, ISO 2540, ISO 2541.**

HSS TiN-tip
METRIC



Diameter		Pilot Length		Overall Length	Order Code	Price/1 TB
Body	Pilot	Min.	Max.			
3.15	1.0	1.3	1.9	31.5	-5142A	691.00
4.00	1.60	2.0	2.8	35.5	-5143A	797.00
5.00	2.00	2.5	3.3	40.0	-5144A	318.00
6.30	2.50	3.1	4.1	45.0	-5145A	1422.00
8.00	3.15	3.9	4.9	50.0	-5146A	1640.00
10.00	4.00	5.0	6.2	56.0	-5147A	2842.00
12.50	5.00	6.3	7.5	63.0	-5148A	2121.00

HSS 5 Piece Metric Set

60° inclusive angle. Manufactured to **BS 328 : Part 2 : 1986, DIN 333A, ISO 866, ISO 2540, ISO 2541.**

Sizes: 5 x 2mm, 6.3 x 2.5mm, 8 x 3.15mm 10 x 4mm and 12.5 x 5mm.

HSS TiN-tip



5 PIECES

Number of Pieces	Weight each	Order Code	Price/1 TB
5	120g	-5155A	5995.00

HSS TiN Tipped Centre Drills

Designed with spiral flutes and various lengths and forms to give high quality centre holes that suit most applications. TiN coating on working parts. 60° inclusive angle. Manufactured to **BS 328 : Part 2 : 1986, DIN 333A, ISO 866, ISO 2540, ISO 2541.**

HSS TiN-tip
INCH



Size	Diameter		Pilot Length		Overall Length	Order Code	Price/1 TB
	Body	Pilot	Min.	Max.			
BS1	1/8"	3/64"	1/16"	5/64"	1 1/2"	-5133A	384.00
BS2	3/16"	1/16"	5/64"	3/32"	1 3/4"	-5134A	438.00
BS3	1/4"	3/32"	1/8"	5/32"	2"	-5135A	493.00
BS4	5/16"	1/8"	5/32"	3/16"	2 1/4"	-5136A	603.00
BS5	7/16"	3/16"	1/4"	9/32"	2 1/2"	-5137A	931.00

HSS TiN Tipped BS Set

Designed with spiral flutes and various lengths and forms to give high quality centre holes. TiN coating on working parts. 60° inclusive angle. Manufactured to **BS 328 : Part 2 : 1986, DIN 333A, ISO 866, ISO 2540, ISO 2541.** Sizes: BS1, BS2, BS3, BS4 and BS5.

HSS TiN-tip



5 PIECES

Number of Pieces	Weight each	Order Code	Price/1 TB
5	114g	-5140A	2515.00

SHERWOOD QUALITY CUTTING TOOLS HSS Centre Drills

Designed with spiral flutes and various lengths and forms to give high quality centre holes that suit most applications. 60° inclusive angle. Manufactured to **BS 328 : Part 2 : 1986, DIN 333A, ISO 866, ISO 2540, ISO 2541.**

HSS
METRIC



C100 Series - Metric

Diameter		Pilot Length		Overall Length	Weight each	Order Code	Price/1 TB
Body	Pilot	Min.	Max.				
3.15	0.80	1.1	1.5	31.5	2g	-1843X	243.00
3.15	1.00	1.3	1.9	31.5	2g	-1844A	253.00
3.15	1.25	1.6	2.2	31.5	3g	-1845B	258.00
4.00	1.60	2.0	2.8	35.5	3g	-1846C	253.00
5.00	2.00	2.5	3.3	40.0	5g	-1847D	258.00
6.30	2.50	3.1	4.1	45.0	9g	-1848E	273.00
8.00	3.15	3.9	4.9	50.0	7g	-1849F	284.00
10.00	4.00	5.0	6.2	56.0	28g	-1850G	351.00
12.50	5.00	6.3	7.5	63.0	45g	-1851H	541.00
16.00	6.30	8.0	9.2	71.0	71g	-1852J	998.00
20.00	8.00	10.0	11.5	83.0	102g	-1852M	1009.00
25.00	10.00	12.8	14.2	103.0	197g	-1852N	1327.00

HSS 5 Piece Metric Set

60° inclusive angle. Manufactured to **BS 328 : Part 2 : 1986, DIN 333A, ISO 866, ISO 2540, ISO 2541.**

Sizes: 5 x 2mm, 6.3 x 2.5mm, 8 x 3.15mm 10 x 4mm and 12.5 x 5mm.

HSS



5 PIECES

Number of Pieces	Weight each	Order Code	Price/1 TB
5	120g	-9150K	1391.00

HSS Centre Drills

Designed with spiral flutes and various lengths and forms to give high quality centre holes that suit most applications. 60° inclusive angle. Manufactured to **BS 328 : Part 2 : 1986, DIN 333A, ISO 866, ISO 2540, ISO 2541.**

HSS

INCH



C100 Series - Inch

Size	Diameter		Pilot Length		Overall Length	Order Code	Price/1 TB
	Body	Pilot	Min.	Max.			
BS00	1/8"	0.025"	0.025"	0.030"	1 1/8"	-1827L	243.00
BS0	1/8"	1/32"	3/64"	1/16"	1 1/4"	-1828M	239.00
BS1	1/8"	3/64"	1/16"	5/64"	1 1/2"	-1829A	199.00
BS2	3/16"	1/16"	5/64"	3/32"	1 3/4"	-1830B	205.00
BS3	1/4"	3/32"	1/8"	5/32"	2"	-1831C	258.00
BS4	5/16"	1/8"	5/32"	3/16"	2 1/4"	-1832D	284.00
BS5	7/16"	3/16"	1/4"	9/32"	2 1/2"	-1833E	390.00
BS6	5/8"	1/4"	5/16"	3/8"	3"	-1835G	852.00
BS7	3/4"	5/16"	13/32"	15/32"	3 1/2"	-1836H	1353.00

HSS 5 Piece BS Set

60° inclusive angle. Manufactured to **BS 328 : Part 2 : 1986, DIN 333A, ISO 866, ISO 2540, ISO 2541.** Sizes: BS1, BS2, BS3, BS4 and BS5.

HSS



5 PIECES

Number of Pieces	Weight each	Order Code	Price/1 TB
5	114g	-9160K	1288.00

CUTTING TOOLS



HSS Extra Length Centre Drills



Ground flute, for drilling centre holes on components prior to machining. Extra length drills particularly useful for drilling centre holes in recesses. Manufactured to **BS 328 : Part 1 : 1986, DIN333A : ISO 86, ISO2540, ISO2541.**



Metric					Inch						
Diameter (mm)		Overall Length	Weight each	Order Code	Price/1 TB	Size	Diameter		Overall Length	Order Code	Price/1 TB
Body	Point						Body	Pilot			
4.00	1.00	120	19g	-1866H	212.00	BS1	1/8"	3/64"	4"	-1881A	356.00
5.00	1.60	120	25g	-1866K	229.00	BS2	3/16"	1/16"	4"	-1882B	366.00
6.00	2.00	120	31g	-1866N	266.00	BS3	1/4"	3/32"	4"	-1883C	469.00
8.00	2.50	120	49g	-1866R	293.00	BS4	5/16"	1/8"	4"	-1884D	582.00
10.00	3.15	120	69g	-1866W	346.00	BS5	7/16"	3/16"	4"	-1885E	670.00
12.50	5.00	120	86g	-1866X	802.00						

HSS Bell Type Centre Drills

Manufactured to **BS 328 : Part 2 : 1986, DIN 333, ISO 2540.**

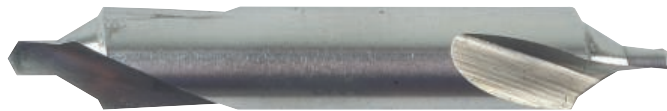

Metric					Inch					
Diameter		Overall Length	Order Code	Price/1 TB	Size	Diameter		Overall Length	Order Code	Price/1 TB
Body	Pilot					Body	Pilot			
4.00	1.00	35.5	-1861K	637.00	BS1B	1/8"	3/64"	1 1/2"	-1853A	372.00
5.00	1.25	40.0	-1861L	691.00	BS2B	3/16"	1/16"	1 3/4"	-1854B	478.00
6.30	1.60	45.0	-1861N	743.00	BS3B	1/4"	3/32"	2"	-1855C	585.00
8.00	2.00	50.0	-1861P	797.00	BS4B	5/16"	1/8"	2 1/4"	-1856D	797.00
10.00	2.50	56.0	-1861Q	1009.00	BS5B	7/16"	5/32"	2 1/2"	-1858F	849.00
11.20	3.15	60.0	-1861R	1167.00						
14.00	4.00	67.0	-1861S	1494.00						
18.00	5.00	75.0	-1861T	3142.00						

Carbide Centre Drills

Used to produce 60° centres in components for subsequent manufacturing operations to be carried out. Tool life is extended and difficult materials may be drilled.

60° included angle. 118° drill point.

Manufactured to **BS 328.**



CARBIDE

KENNEDY Carbide Centre Drills

Used to produce 60° centres in components for subsequent manufacturing operations to be carried out. Tool life is extended and difficult materials may be drilled. 60° included angle. 118° drill point.

Manufactured to **BS 328.**



CARBIDE

Tolerances
Cutting Diameter +0.0005"
Shank Diameter +0.0010"



Tolerances
Cutting Diameter +0.0005"
Shank Diameter +0.0010"

Inch						
Size	Diameter		Overall Length	Weight each	Order Code	Price/1 TB
	Body	Drill				
BS1	1/8"	3/64"	1 1/2"	10g	-8010K	1067.00
BS2	3/16"	5/64"	1 7/8"	10g	-8020K	1564.00
BS3	1/4"	7/64"	2"	20g	-8030K	1983.00
BS4	5/16"	1/8"	2 1/8"	30g	-8040K	2722.00
BS5	7/16"	3/16"	2 3/4"	70g	-8050K	4049.00
BS6	1/2"	7/32"	3"	90g	-8060K	5612.00



Metric						
Diameter	Pilot Length		Overall Length	Weight each	Order Code	Price/1 TB
	Body	Drill				
4.00	1.60	2.0 2.8	35.5	3g	-8110K	641.00
5.00	2.00	2.5 3.3	40.0	5g	-8120K	712.00
6.30	2.50	3.1 4.1	45.0	9g	-8130K	846.00
8.00	3.15	3.9 4.9	50.0	7g	-8140K	1032.00
10.00	4.00	5.0 6.2	56.0	28g	-8150K	1351.00
12.50	5.00	6.3 7.5	63.0	45g	-8160K	2133.00
16.00	6.30	8.0 9.2	71.0	123g	-8180K	4547.00

Inch						
Size	Diameter		Overall Length	Weight each	Order Code	Price/1 TB
	Body	Drill				
BS1	1/8"	3/64"	1 1/2"	10g	-9010K	1167.00
BS2	3/16"	5/64"	1 7/8"	10g	-9020K	1751.00
BS3	1/4"	7/64"	2"	20g	-9030K	1989.00
BS4	5/16"	1/8"	2 1/8"	30g	-9040K	2706.00
BS5	7/16"	3/16"	2 3/4"	70g	-9050K	4085.00
BS6	1/2"	7/32"	3"	90g	-9060K	6695.00

PRODUCTS ARE ONLY AVAILABLE VIA YOUR DISTRIBUTOR



HSS General Purpose Stub Drills

General purpose drills for use on automatics and turret lathes. Suitable for drilling steels, cast iron, alloy steel and malleable cast iron. Point angle: 118°, helix angle: normal, web thickness: standard, relief angle: 10° - 20°, tolerance of diameter: h8, tolerance of shank: f11.
Manufactured to **BS 328: Part 1: 1986/DIN 1897**.



HSS

CUTTING TOOLS



DIN 1897 For Dimensions
BS 328 See Page 28

Series S100 - Metric

Dia. (mm)	Order Code SHR-025	Price/10 TB
1.00	-1227H	1339.00
1.50	-1233P	1133.00
1.80	-1236S	1597.00
2.00	-1240X	927.00
2.10	-1242N	2163.00
2.20	-1243A	2163.00
2.30	-1245C	1442.00
2.40	-1246D	1391.00
2.50	-1248F	927.00
2.60	-1250H	1339.00
2.70	-1252K	1391.00
2.80	-1253L	1391.00
2.90	-1255N	1597.00
3.00	-1257Q	927.00
3.10	-1258R	1442.00
3.20	-1259S	1494.00
3.30	-1260T	979.00
3.40	-1261V	1751.00
3.50	-1262W	1082.00
3.60	-1263X	1700.00
3.70	-1264Y	1803.00
3.80	-1265N	1803.00
3.90	-1266A	1854.00
4.00	-1267B	1236.00
4.10	-1268C	1236.00
4.20	-1269D	1339.00
4.30	-1270E	2112.00
4.40	-1271F	2163.00
4.50	-1272G	1391.00

PRICED PER 10

Dia. (mm)	Order Code SHR-025	Price/10 TB
4.60	-1273H	2215.00
4.80	-1275K	2369.00
4.90	-1276L	1494.00
5.00	-1277M	1494.00
5.10	-1278N	2627.00
5.20	-1279P	2421.00
5.30	-1280Q	2524.00
5.40	-1281R	2781.00
5.50	-1282S	1803.00
5.60	-1283T	2833.00
5.80	-1285W	1957.00
5.90	-1286X	3245.00
6.00	-1287Y	2009.00
6.10	-1288N	3348.00
6.20	-1289A	3451.00
6.30	-1290B	3502.00
6.40	-1291C	3296.00
6.50	-1292D	2318.00
6.70	-1294F	3811.00
6.80	-1295G	3657.00
6.90	-1296H	4119.00
7.00	-1297J	2627.00
7.10	-1298K	4378.00
7.20	-1299L	4481.00
7.30	-1300M	4532.00
7.40	-1301N	4790.00
7.50	-1302P	3193.00
7.60	-1303Q	4996.00
7.80	-1305S	5099.00

PRICED PER 10

Dia. (mm)	Order Code SHR-025	Price/10 TB
8.00	-1307V	3348.00
8.10	-1308W	5614.00
8.20	-1309X	5717.00
8.40	-1311N	6077.00
8.50	-1312A	3863.00
8.60	-1313B	6386.00
8.70	-1314C	6335.00
8.80	-1315D	6489.00
8.90	-1316E	6901.00
9.00	-1317F	4275.00
9.10	-1318G	7365.00
9.20	-1319H	7416.00
9.40	-1321K	7674.00
9.50	-1322L	4841.00
9.60	-1323M	7880.00
9.70	-1324N	7880.00
9.80	-1325P	8292.00
10.00	-1327R	5356.00
10.10	-1328S	8652.00
10.20	-1329T	8292.00
10.30	-1330V	9529.00
10.50	-1332X	8549.00
10.80	-1335A	9500.00
11.00	-1337C	6747.00
11.50	-1342H	10403.00
12.00	-1347N	7983.00
12.50	-1352T	12566.00
13.00	-1357N	963.00

PRICED PER 1

Dia. (mm)	Order Code SHR-025	Price/1 TB
13.50	-1359B	1597.00
14.00	-1361D	1597.00
14.50	-1362E	1906.00
14.80	-1362R	3500.00
15.00	-1363F	2112.00
15.50	-1364G	2215.00
16.00	-1365H	2369.00
16.50	-1366J	2524.00
17.00	-1367K	2730.00
17.50	-1368L	2627.00
18.00	-1369M	3142.00
18.50	-1370N	3296.00
19.00	-1371P	3451.00
19.50	-1372Q	3657.00
20.00	-1373R	3863.00
21.00	-1374S	4378.00
22.00	-1375T	4841.00

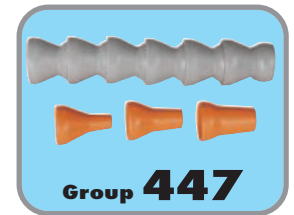

DIN 1897 For Dimensions
BS 328 See Page 28

Series S100 - Inch

Dia. (inch)	Order Code SHR-025	Price/10 TB
1/16"	-1194C	1082.00
3/32"	-1194E	876.00
1/8"	-1194G	979.00
9/64"	-1194H	1082.00
5/32"	-1194J	1185.00

PRICED PER 10

Dia. (inch)	Order Code SHR-025	Price/10 TB
11/64"	-1194K	1339.00
3/16"	-1194L	1391.00
13/64"	-1194M	1597.00
7/32"	-1194N	1854.00
1/4"	-1194Q	2266.00

PRICED PER 10

Dia. (inch)	Order Code SHR-025	Price/10 TB
5/16"	-1194V	3245.00
11/32"	-1194X	4017.00
3/8"	-1194Z	4790.00
7/16"	-1195D	6901.00
1/2"	-1195H	8961.00

PRICED PER 1

Dia. (inch)	Order Code SHR-025	Price/1 TB
33/64"	-1195J	1751.00
9/16"	-1195M	1751.00
5/8"	-1195R	1597.00
3/4"	-1196A	2524.00

HSS General Purpose Stub Drills - Bright Finish

General purpose drills for use on automatics and turret lathes. Suitable for drilling steels, cast iron, alloy steel and malleable cast iron. Point angle: 118°, helix angle: normal, web thickness: standard, relief angle: 10° - 20°, tolerance of diameter: h8, tolerance of shank: f11.
Manufactured to **BS 328: Part 1: 1986/DIN 1897**.

HSS



DIN 1897 For Dimensions
BS 328 See Page 28

Metric

Dia. (mm)	Order Code SHR-025	Price/10 TB
2.00	-1170D	979.00
2.50	-1170L	979.00
3.00	-1170R	979.00
3.20	-1170T	1494.00

PRICED PER 10

Dia. (mm)	Order Code SHR-025	Price/10 TB
3.30	-1170W	979.00
3.50	-1170Z	1082.00
4.00	-1171E	1236.00
4.20	-1171H	1339.00

PRICED PER 10

Dia. (mm)	Order Code SHR-025	Price/10 TB
5.00	-1171V	1545.00
6.00	-1172K	1957.00
8.00	-1173Z	3348.00
10.00	-1175K	5356.00

PRICED PER 10

Dia. (mm)	Order Code SHR-025	Price/10 TB
12.00	-1177M	7983.00

PRODUCTS ARE ONLY AVAILABLE VIA YOUR DISTRIBUTOR

GROUP 025 STUB DRILLS

SWISS+TECH HSS TiN Coated Stub Drills

General purpose drill for use on automatics and turret lathes. Suitable for drilling steels, cast iron, alloy steel and malleable cast iron. TiN coating provides longer tool life or increased cutting speeds. Point angle: 135°, helix angle: normal, web thickness: normal, tolerance of diameter: h8, tolerance of shank: f11.

Manufactured to **BS 328, DIN 1897 RN.**



HSS TiN

DIN 1897 For Dimensions
BS 328 See Page 28



DIN 1412C 135°

Series 2001 Metric

Dia. (mm)	Order Code SWT-125	Price/1 TB	Dia. (mm)	Order Code SWT-125	Price/1 TB	Dia. (mm)	Order Code SWT-125	Price/1 TB	Dia. (mm)	Order Code SWT-125	Price/1 TB
2.50	-2025A	542.00	4.20	-2042A	603.00	6.80	-2068A	1384.00	12.00	-2120A	3973.00
3.00	-2030A	542.00	5.00	-2050A	662.00	8.00	-2080A	1221.00	13.00	-2130A	4208.00
3.20	-2032A	603.00	5.20	-2052A	723.00	8.50	-2085A	1564.00			
4.00	-2040A	603.00	6.50	-2065A	1263.00	9.00	-2090A	1624.00			

HSS-Co Heavy Duty Cobalt Stub Drills

Heavy duty drill made of cobalt material with excellent heat resistance. For drilling steels up to 1,400N/mm², stainless steel, heat resistant steels and bronze. Ideally suited for volume production on automatics. Point angle: 135°, helix angle: normal, web thickness: strengthened, tolerance of diameter: h8, tolerance of shank: f11.

Manufactured to **BS 328, DIN 1897RN.** Point to **DIN 1412C.**

HSS-Co

DIN 1897 For Dimensions
BS 328 See Page 28



DIN 1412C 135°

Series 2010 Metric

Dia. (mm)	Order Code SWT-125	Price/1 TB	Dia. (mm)	Order Code SWT-125	Price/1 TB	Dia. (mm)	Order Code SWT-125	Price/1 TB	Dia. (mm)	Order Code SWT-125	Price/1 TB
1.00	-2210A	362.00	2.90	-2229A	422.00	4.80	-2248A	542.00	7.80	-2278A	1684.00
1.20	-2212A	362.00	3.00	-2230A	301.00	4.90	-2249A	542.00	8.00	-2280A	903.00
1.30	-2213A	362.00	3.10	-2231A	362.00	5.00	-2250A	482.00	8.20	-2282A	1984.00
1.60	-2216A	362.00	3.20	-2232A	362.00	5.20	-2252A	723.00	8.40	-2284A	2200.00
1.70	-2217A	362.00	3.30	-2233A	422.00	5.50	-2255A	603.00	8.50	-2285A	1022.00
1.80	-2218A	362.00	3.40	-2234A	422.00	6.00	-2260A	662.00	9.00	-2290A	1143.00
2.10	-2221A	362.00	3.50	-2235A	422.00	6.20	-2262A	1203.00	9.50	-2295A	1263.00
2.30	-2223A	362.00	3.70	-2237A	422.00	6.40	-2264A	1263.00	10.00	-2300A	1384.00
2.40	-2224A	362.00	4.00	-2240A	422.00	6.50	-2265A	723.00	10.20	-2302A	2405.00
2.50	-2225A	362.00	4.10	-2241A	433.00	6.80	-2268A	1384.00	10.50	-2305A	2525.00
2.60	-2226A	362.00	4.20	-2242A	433.00	7.00	-2270A	782.00	11.00	-2310A	2525.00
2.70	-2227A	422.00	4.30	-2243A	482.00	7.50	-2275A	903.00	12.00	-2320A	3367.00
2.80	-2228A	422.00	4.50	-2245A	482.00	7.70	-2277A	1624.00	13.00	-2330A	3788.00

HSS-Co TiN Coated Heavy Duty Stub Drills

Heavy duty drill made of cobalt material with excellent heat resistance. For drilling steels up to 1,400N/mm², stainless steel, heat resistant steels and bronze. Ideally suited for volume production on automatics. TiN coating provides longer tool life or increased cutting speeds.

Point angle: 135°, helix angle: normal, web thickness: strengthened, tolerance of diameter: h8, tolerance of shank: f11.

Manufactured to **BS 328, DIN 1897RN.** Point to **DIN 1412C.**

HSS-Co TiN

DIN 1897 For Dimensions
BS 328 See Page 28



DIN 1412C 135°

Series 2020 Metric

Dia. (mm)	Order Code SWT-125	Price/1 TB	Dia. (mm)	Order Code SWT-125	Price/1 TB	Dia. (mm)	Order Code SWT-125	Price/1 TB	Dia. (mm)	Order Code SWT-125	Price/1 TB
1.50	-2415A	782.00	3.30	-2433A	842.00	5.10	-2451A	1323.00	8.00	-2480A	1864.00
1.60	-2416A	782.00	3.50	-2435A	842.00	5.20	-2452A	1323.00	8.50	-2485A	1984.00
2.00	-2420A	782.00	4.00	-2440A	903.00	5.50	-2455A	1203.00	10.00	-2500A	2705.00
2.20	-2422A	782.00	4.10	-2441A	903.00	6.00	-2460A	1263.00	10.20	-2502A	4990.00
2.40	-2424A	782.00	4.20	-2442A	903.00	6.10	-2461A	2525.00	11.00	-2510A	5170.00
2.50	-2425A	723.00	4.40	-2444A	963.00	6.20	-2462A	2405.00	12.00	-2520A	6492.00
2.60	-2426A	782.00	4.50	-2445A	903.00	6.50	-2465A	1684.00	13.00	-2530A	7032.00
3.00	-2430A	782.00	4.80	-2448A	1100.00	6.80	-2468A	2766.00			
3.20	-2432A	782.00	5.00	-2450A	963.00	7.00	-2470A	1744.00			

KENNEDY *Solid Carbide*
QUALITY INDUSTRIAL TOOLING *Stub Drills*

For drilling into steel, cast steel, cast iron, chilled cast iron, malleable cast iron, non-ferrous materials and abrasive plastic.
Point angle: 118°, helix angle: 30°, tolerance of diameter: h7, tolerance of shank: h6.
Manufactured to **DIN 6539**.

CARBIDE



Metric					Metric					Metric				
Dia. (mm)	Flute Length	Overall Length	Order Code KEN-158	Price/1 TB	Dia. (mm)	Flute Length	Overall Length	Order Code KEN-158	Price/1 TB	Dia. (mm)	Flute Length	Overall Length	Order Code KEN-158	Price/1 TB
1.00	6.0	26.0	-3100K	526.00	2.70	16.0	46.0	-3270K	759.00	4.20	22.0	55.0	-3420K	1051.00
1.10	6.0	26.0	-3110K	526.00	2.80	16.0	46.0	-3280K	759.00	4.40	24.0	58.0	-3440K	1200.00
1.20	8.0	30.0	-3120K	526.00	2.90	16.0	46.0	-3290K	770.00	4.50	24.0	58.0	-3450K	1109.00
1.30	8.0	30.0	-3130K	573.00	3.00	16.0	46.0	-3300K	701.00	5.00	26.0	62.0	-3500K	1226.00
1.40	9.0	32.0	-3140K	573.00	3.10	18.0	49.0	-3310K	797.00	5.10	26.0	62.0	-3510K	1226.00
1.50	9.0	32.0	-3150K	573.00	3.20	18.0	49.0	-3320K	817.00	5.20	26.0	62.0	-3520K	1343.00
1.60	10.0	34.0	-3160K	573.00	3.30	18.0	49.0	-3330K	817.00	5.50	28.0	66.0	-3550K	1459.00
1.70	10.0	34.0	-3170K	573.00	3.50	20.0	52.0	-3350K	844.00	6.00	28.0	66.0	-3600K	1401.00
1.80	11.0	36.0	-3180K	573.00	3.60	20.0	52.0	-3360K	876.00	7.00	34.0	74.0	-3700K	1926.00
2.00	12.0	38.0	-3200K	622.00	3.70	20.0	52.0	-3370K	934.00	8.00	37.0	79.0	-3800K	2163.00
2.20	13.0	40.0	-3220K	637.00	3.80	22.0	55.0	-3380K	992.00	8.50	37.0	79.0	-3850K	3035.00
2.40	14.0	43.0	-3240K	701.00	3.90	22.0	55.0	-3390K	992.00	9.00	40.0	84.0	-3900K	3035.00
2.50	14.0	43.0	-3250K	701.00	4.00	22.0	55.0	-3400K	876.00	10.00	43.0	89.0	-4100K	3385.00
2.60	14.0	43.0	-3260K	728.00	4.10	22.0	55.0	-3410K	1051.00					

SHERWOOD *Solid Carbide*
QUALITY CUTTING TOOLS *Stub Drills*

For drilling into steel, cast steel, cast iron, chilled cast iron, malleable cast iron, non-ferrous materials and abrasive plastic.
Point angle: 118°, helix angle: 30°, tolerance of diameter: h7, tolerance of shank: h6.
Manufactured to **Works Standard**.

CARBIDE



Metric					Metric					Metric				
Dia. (mm)	Flute Length	Overall Length	Order Code SHR-158	Price/1 TB	Dia. (mm)	Flute Length	Overall Length	Order Code SHR-158	Price/1 TB	Dia. (mm)	Flute Length	Overall Length	Order Code SHR-158	Price/1 TB
1.0	11.0	30.0	-3100K	437.00	3.6	22.0	50.0	-3360K	716.00	6.2	30.0	65.0	-3620K	1380.00
1.1	11.0	30.0	-3110K	437.00	3.7	22.0	50.0	-3370K	716.00	6.3	30.0	65.0	-3630K	1380.00
1.2	13.0	30.0	-3120K	437.00	3.8	22.0	50.0	-3380K	743.00	6.5	30.0	65.0	-3650K	1380.00
1.3	13.0	30.0	-3130K	437.00	3.9	22.0	50.0	-3390K	770.00	6.8	30.0	65.0	-3680K	1645.00
1.4	13.0	30.0	-3140K	437.00	4.0	22.0	50.0	-3400K	797.00	7.0	30.0	65.0	-3700K	1858.00
1.5	13.0	30.0	-3150K	437.00	4.1	25.0	50.0	-3410K	849.00	7.5	34.0	70.0	-3750K	2016.00
1.6	17.5	40.0	-3160K	437.00	4.2	25.0	50.0	-3420K	849.00	8.0	34.0	70.0	-3800K	2096.00
1.7	17.5	40.0	-3170K	437.00	4.3	25.0	50.0	-3430K	849.00	8.1	34.0	70.0	-3810K	2096.00
1.8	17.5	40.0	-3180K	437.00	4.4	25.0	50.0	-3440K	849.00	8.2	34.0	70.0	-3820K	2096.00
1.9	17.5	40.0	-3190K	437.00	4.5	25.0	50.0	-3450K	849.00	8.5	34.0	70.0	-3850K	2096.00
2.0	17.5	40.0	-3200K	437.00	4.6	25.0	50.0	-3460K	876.00	8.7	34.0	75.0	-3870K	2318.00
2.1	17.5	40.0	-3210K	504.00	4.7	25.0	50.0	-3470K	876.00	9.0	34.0	75.0	-3900K	2282.00
2.2	17.5	40.0	-3220K	504.00	4.8	25.0	50.0	-3480K	876.00	9.2	34.0	75.0	-3920K	2494.00
2.3	17.5	40.0	-3230K	504.00	4.9	25.0	50.0	-3490K	876.00	9.5	34.0	75.0	-3950K	2547.00
2.4	17.5	40.0	-3240K	504.00	5.0	25.0	50.0	-3500K	968.00	10.0	34.0	75.0	-4100K	3025.00
2.5	17.5	40.0	-3250K	504.00	5.1	25.0	50.0	-3510K	1009.00	10.2	50.0	100.0	-4120K	3131.00
2.6	20.0	45.0	-3260K	504.00	5.2	25.0	50.0	-3520K	1009.00	10.5	50.0	100.0	-4150K	3343.00
2.7	20.0	45.0	-3270K	585.00	5.3	25.0	50.0	-3530K	1009.00	11.0	50.0	100.0	-4110K	3451.00
2.8	20.0	45.0	-3280K	585.00	5.4	25.0	50.0	-3540K	1009.00	12.0	50.0	100.0	-4120K	3714.00
2.9	20.0	45.0	-3290K	585.00	5.5	25.0	50.0	-3550K	1009.00	13.0	60.0	107.0	-4130K	4510.00
3.0	20.0	45.0	-3300K	637.00	5.6	25.0	50.0	-3560K	1009.00	14.0	60.0	107.0	-4140K	7957.00
3.1	22.0	50.0	-3310K	637.00	5.7	25.0	50.0	-3570K	1009.00	15.0	65.0	115.0	-4150K	10875.00
3.2	22.0	50.0	-3320K	637.00	5.8	25.0	50.0	-3580K	1167.00	16.0	65.0	115.0	-4160K	12201.00
3.3	22.0	50.0	-3330K	637.00	5.9	25.0	50.0	-3590K	1167.00	17.0	73.0	123.0	-4170K	14323.00
3.4	22.0	50.0	-3340K	691.00	6.0	25.0	50.0	-3600K	1353.00	18.0	73.0	123.0	-4180K	15384.00
3.5	22.0	50.0	-3350K	691.00	6.1	30.0	65.0	-3610K	1380.00	20.0	79.0	131.0	-4200K	19627.00

Solid Carbide Screw Drills

Primarily designed for removing broken taps or bolts without damaging the component surface. By drilling the core of a tap it is possible to remove the remaining pieces with a scriber. Screw drills are also suitable for drilling other hard materials including: hardened steels, glass, stellite etc. Select screw drill as per tap diameter. Steady manual feed component and spindle stability are vital. Drills should be running between 1500 and 3500 revs/min. A steady and continuous manual feed should be applied. No cutting fluid required.

CARBIDE



Type	Size	Weight each	Order Code KEN-154	Price/1 TB
SD2	2mm for M3*	10g	-1020K	1009.00
SD3	3mm for M4 - M5*	10g	-1030K	1009.00
SD4	4mm for M6 - M7*	20g	-1040K	1167.00
SD5	5mm for M8 - M10*	30g	-1050K	1698.00
SD6	6mm for M10 - M12*	30g	-1060K	1539.00

*or inch equivalent

Solid Carbide Screw Drill Set

Contents:
SD2, SD3, SD4, SD5 and SD6.

5
PIECES

Number of Pieces	Weight per set	Order Code KEN-154	Price/1 TB
5	80g	-1100K	5835.00

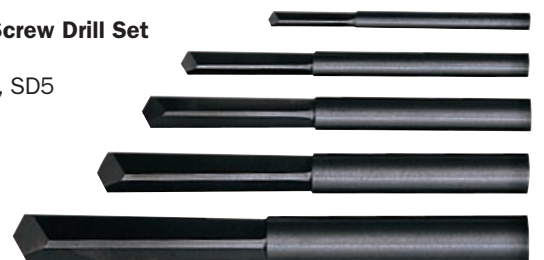

GROUP 025 STANDARD LENGTH DRILLS

SENATOR QUALITY TOOLING *HSS Roll Forged Jobber Drills*

For HSS Ground Flute Jobber Drills for industrial applications, please see page 36



Senator jobber drills are roll forged from HSS, ensuring uninterrupted grain structure. This provides exceptional strength and durability. Tips are ground for effective cutting. Suitable for drilling wood, plastic, carbon and plain steels where the cutting efficiency of ground flute is not required.

Manufactured to **BS 328 : Part 1 : 1986 & DIN 338 Type N.**



DIN 338 For Dimensions
BS 328 See Pages 32 - 33

HSS

CUTTING TOOLS

Metric		PRICED PER 10
Dia. (mm)	Order Code SEN-025	Price/10 TB
1.00	-0040N	47.00
1.50	-0050N	57.00
2.00	-0060K	103.00
2.50	-0070W	103.00
2.80	-0076C	103.00
3.00	-0080G	103.00
3.20	-0083K	103.00
3.30	-0085M	124.00
3.50	-0087P	124.00
3.80	-0091T	170.00
4.00	-0093W	160.00
4.20	-0095Y	170.00
4.50	-0099C	181.00

		PRICED PER 10
Dia. (mm)	Order Code SEN-025	Price/10 TB
4.80	-0103G	191.00
4.90	-0104H	181.00
5.00	-0105J	205.00
5.20	-0107L	304.00
5.50	-0111Q	258.00
6.00	-0117X	340.00
6.20	-0119N	361.00
6.50	-0123D	361.00
6.80	-0127H	490.00
7.00	-0129K	514.00
7.50	-0135R	567.00
8.00	-0141Y	670.00
8.50	-0147E	696.00

		PRICED PER 10
Dia. (mm)	Order Code SEN-025	Price/10 TB
9.00	-0153L	773.00
9.50	-0159S	979.00
10.00	-0165N	1288.00
10.20	-0167B	1339.00
10.50	-0171F	1391.00
11.00	-0177M	1391.00
11.50	-0183T	1545.00
12.00	-0189A	1803.00
12.50	-0195G	2009.00
13.00	-0201N	2163.00
14.00	-0213B	2266.00

HSS Roll Forged Jobber Drill Sets

Roll forged from HSS, ensuring uninterrupted grain structure. This provides exceptional strength and durability. Tips are ground for effective cutting. Suitable for drilling wood, plastic, carbon and plain steels where the cutting efficiency of ground flute is not required. Manufactured to **BS 328 : Part 1 : 1986 & DIN 338 Type N.**

x 0.5mm
1.0 ~ 10.0

19
PIECES

19 Piece Set
Contents (mm):

1.0	3.0	5.0	7.0	9.0
1.5	3.5	5.5	7.5	9.5
2.0	4.0	6.0	8.0	10.0
2.5	4.5	6.5	8.5	

Weight each	Order Code SEN-025	Price/1 TB
0.65kg	-9250K	823.00



x 0.5mm
1.0 ~ 13.0

25
PIECES

25 Piece Set
Contents (mm):

1.0	3.5	6.0	8.5	11.0
1.5	4.0	6.5	9.0	11.5
2.0	4.5	7.0	9.5	12.0
2.5	5.0	7.5	10.0	12.5
3.0	5.5	8.0	10.5	13.0

Weight each	Order Code SEN-025	Price/1 TB
1.60kg	-9150K	1999.00



x 0.1mm
6.0 ~ 10.0

41 Piece Set
Contents (mm):

41
PIECES

6.0	6.9	7.8	8.7	9.6
6.1	7.0	7.9	8.8	9.7
6.2	7.1	8.0	8.9	9.8
6.3	7.2	8.1	9.0	9.9
6.4	7.3	8.2	9.1	10.0
6.5	7.4	8.3	9.2	
6.6	7.5	8.4	9.3	
6.7	7.6	8.5	9.4	
6.8	7.7	8.6	9.5	

Weight each	Order Code SEN-025	Price/1 TB
2.10kg	-9110K	2627.00

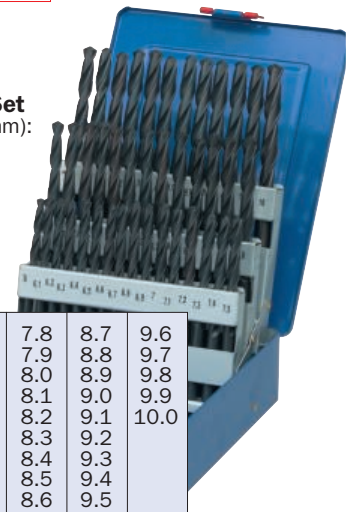

HSS Roll Forged Jobber Drill Sets

Roll forged from HSS, ensuring uninterrupted grain structure. This provides exceptional strength and durability. Tips are ground for effective cutting. Suitable for drilling wood, plastic, carbon and plain steels where the cutting efficiency of ground flute is not required.

Manufactured to **BS 328 : Part 1 : 1986 & DIN 338 Type N.**

x 0.5mm
1.0 ~ 10.0

170 Piece Set
Contents (mm):

1.0 x 10	4.5 x 10	8.0 x 10
1.5 x 10	5.0 x 10	8.5 x 5
2.0 x 10	5.5 x 10	9.0 x 5
2.5 x 10	6.0 x 10	9.5 x 5
3.0 x 10	6.5 x 10	10.0 x 5
3.5 x 10	7.0 x 10	
4.0 x 10	7.5 x 10	

Weight each	Order Code SEN-025	Price/1 TB
3.8kg	-9300K	3863.00



170
PIECES

x 0.1mm
1.0 ~ 6.0

51 Piece Set
Contents (mm):

51
PIECES

1.0	1.9	2.8	3.7	4.6	5.5
1.1	2.0	2.9	3.8	4.7	5.6
1.2	2.1	3.0	3.9	4.8	5.7
1.3	2.2	3.1	4.0	4.9	5.8
1.4	2.3	3.2	4.1	5.0	5.9
1.5	2.4	3.3	4.2	5.1	6.0
1.6	2.5	3.4	4.3	5.2	
1.7	2.6	3.5	4.4	5.3	
1.8	2.7	3.6	4.5	5.4	

Weight each	Order Code SEN-025	Price/1 TB
0.60kg	-9060K	926.00

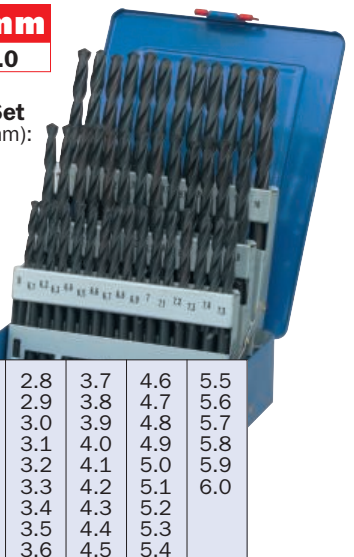

SENATOR QUALITY TOOLING HSS Tap & Drill Sets

Industrial quality. Ground flute, blue finish. Supplied in indexing metal case. Manufactured to **BS328 : Part 1 : 1986, DIN 338N & ANSI B94 -11M.**

28 Piece Set Contents (mm):
Taps: (taper, second and bottom): M3, M4, M5, M6, M8, M10 and M12.
Drills: 2.5, 3.3, 4.2, 5.0, 6.8, 8.5 and 10.2mm.



HSS

METRIC

x 0.7mm
2.5 ~ 10.2

28
PIECES

DIN 338 For Dimensions
BS 328 See Pages 32 - 33

Weight each	Order Code SEN-025	Price/1 TB
	-9960K	3605.00

STANDARD LENGTH DRILLS

Multi-Purpose 'Dial-A-Drill' Set

18 Piece Drill Set

Designed to satisfy countless tasks around the home and workshop - a drill bit for every job!. Supplied in a robust 'dial a drill' case for easy selection and compact storage.

Contents:

- 6 x wood drills with 'lip and spur' self centering/self starting points. Suitable for all types of timber. Sizes 3, 4, 5, 6, 8 and 10mm.
- 6 x masonry drills with TCT drill point. Suitable for tiles, ceramics and all light building materials. Sizes 3, 4, 5, 6, 8 and 10mm.
- 6 x HSS drills (Jobber) with roll forged flutes. Suitable for use in portable power tools in all types of materials. Sizes 3, 4, 5, 6, 8 and 10mm.



Weight each	Order Code SEN-025	Price/1 TB
452g	-9500K	308.00



18
PIECES

CUTTING TOOLS

SHERWOOD QUALITY CUTTING TOOLS HSS Reduced Shank Drills (Blacksmiths)

1/2" parallel shank. General purpose drills for light duty work, for drilling steels, cast iron, nickel brass and graphite. Reduced parallel shank 1/2". Point angle: 118°, helix angle: normal, web thickness: standard, tolerance of diameter: h8, tolerance of shank: 0.01/0.08. Manufactured to works standard.



Black Oxidised Finish

Metric				
Diameter (mm)	Flute Length	Overall Length	Order Code SHR-025	Price/1 TB
13.00	78.0	150.0	-1805A	948.00
13.50	78.0	150.0	-1805B	1539.00
14.00	78.0	150.0	-1806C	903.00
14.50	78.0	150.0	-1806D	1698.00
15.00	78.0	150.0	-1807E	1009.00
15.50	78.0	150.0	-1807F	1878.00
16.00	78.0	150.0	-1808G	1019.00
16.50	78.0	150.0	-1808H	1995.00
17.00	78.0	150.0	-1809J	1221.00
17.50	78.0	150.0	-1809K	2282.00
18.00	78.0	150.0	-1810L	1348.00
18.50	78.0	150.0	-1810M	2494.00
19.00	78.0	150.0	-1811N	1592.00
19.50	85.0	150.0	-1811P	2743.00
20.00	85.0	150.0	-1812Q	1619.00
21.00	85.0	150.0	-1813R	2070.00
22.00	85.0	150.0	-1814S	2101.00
23.00	85.0	150.0	-1815T	2494.00
24.00	85.0	150.0	-1816V	2680.00
25.00	85.0	150.0	-1817W	2918.00
26.00	85.0	150.0	-1818X	4085.00
27.00	85.0	150.0	-1819Y	5305.00
28.00	85.0	150.0	-1820Z	5571.00
29.00	85.0	150.0	-1821A	5835.00
30.00	85.0	150.0	-1822B	6896.00
32.00	85.0	150.0	-1824D	7693.00

Inch

Diameter (Inch)	Flute Length	Overall Length	Order Code SHR-025	Price/1 TB
9/16"	3 1/16"	6"	-1764E	927.00
19/32"	3 1/16"	6"	-1766G	1298.00
5/8"	3 1/16"	6"	-1768J	1082.00
41/64"	3 1/16"	6"	-1769K	1236.00
21/32"	3 1/16"	6"	-1770L	1515.00
11/16"	3 1/16"	6"	-1772N	1391.00
3/4"	3 1/16"	6"	-1776S	1453.00
13/16"	3 3/8"	6"	-1780X	2009.00
7/8"	3 3/8"	6"	-1784B	2112.00
15/16"	3 3/8"	6"	-1788F	2854.00
1"	3 3/8"	6"	-1792K	2730.00
1 1/16"	3 3/8"	6"	-1794M	3657.00
1 1/8"	3 3/8"	6"	-1796P	4069.00
1 1/4"	3 3/8"	6"	-1800T	5150.00

HSS Reduced Shank Drill Set (Blacksmiths)

5 Piece Set Contents:
14, 16, 18, 20 and 22mm.

5
PIECES



Number of Pieces	Order Code SHR-025	Price/1 TB
5	-8960K	4119.00

Bright Finish - TiN Tipped



HSS TiN-tip

Diameter (mm)	Flute Length	Overall Length	Order Code SHR-025	Price/1 TB
14.00	78.0	150.0	-1736C	1288.00
15.00	78.0	150.0	-1737E	1391.00
16.00	78.0	150.0	-1738G	1442.00

Diameter (mm)	Flute Length	Overall Length	Order Code SHR-025	Price/1 TB
17.00	78.0	150.0	-1739J	1648.00
18.00	78.0	150.0	-1740L	1803.00
19.00	78.0	150.0	-1741P	1906.00

Diameter (mm)	Flute Length	Overall Length	Order Code SHR-025	Price/1 TB
20.00	85.0	150.0	-1742Q	2009.00
22.00	85.0	150.0	-1744S	2936.00
25.00	85.0	150.0	-1747W	3605.00

PRODUCTS ARE ONLY AVAILABLE VIA YOUR DISTRIBUTOR

GROUP 025 STANDARD LENGTH DRILLS

SHERWOOD QUALITY CUTTING TOOLS HSS Jobber Drills Metric - Bright Finish

General purpose drills for steels, cast steel, grey cast iron, malleable cast iron, nickel brass, aluminium alloy and graphite. Point angle: 118°, helix angle: normal, web thickness: standard, relief angle: 10° - 20°, tolerance of diameter: h8, tolerance of shank: f11. Manufactured to **BS 328/DIN338RN**.

Bright Finish

Drills with a bright finish are supplied in the as-ground condition and such tools are used generally in the machining of non-ferrous materials.



HSS

METRIC

INCH



DIN 338 For Dimensions
BS 328 See Pages 32 - 33

CUTTING TOOLS

Series J100 - Metric		PRICED PER 10
Dia. (mm)	Order Code SHR-025	Price/10 TB
1.00	-0231B	474.00
1.10	-0231D	618.00
1.20	-0231F	495.00
1.30	-0231H	546.00
1.40	-0231K	526.00
1.50	-0231M	412.00
1.60	-0231P	412.00
1.70	-0231R	433.00
1.80	-0231T	433.00
1.90	-0231W	433.00
1.95	-0231Y	660.00
2.00	-0232A	382.00
2.10	-0232C	433.00
2.20	-0232E	433.00
2.30	-0232G	433.00
2.40	-0232J	433.00
2.50	-0232L	371.00
2.60	-0232N	433.00
2.70	-0232Q	433.00
2.80	-0232S	433.00
2.90	-0232V	392.00
3.00	-0232X	382.00
3.10	-0232Z	433.00
3.20	-0233B	433.00
3.30	-0233D	412.00
3.40	-0233F	433.00
3.50	-0233H	443.00
3.60	-0233K	515.00
3.70	-0233M	464.00
3.80	-0233P	515.00
3.90	-0233R	515.00
4.00	-0233T	515.00
4.10	-0233W	541.00
4.20	-0233Y	515.00
4.30	-0234A	598.00
4.40	-0234C	637.00
4.50	-0234E	541.00
4.60	-0234G	669.00
4.70	-0234J	691.00
4.80	-0234L	701.00
4.90	-0234N	721.00
5.00	-0234Q	617.00
5.10	-0234S	765.00
5.20	-0234V	785.00
5.30	-0234X	807.00
5.40	-0234Z	828.00

Series J100 - Metric		PRICED PER 10
Dia. (mm)	Order Code SHR-025	Price/10 TB
5.50	-0235B	849.00
5.60	-0235D	871.00
5.70	-0235F	891.00
5.80	-0235H	923.00
5.90	-0235K	945.00
6.00	-0235M	850.00
6.10	-0235P	1082.00
6.20	-0235R	1108.00
6.30	-0235T	1123.00
6.40	-0235W	1133.00
6.50	-0235Y	1236.00
6.60	-0236A	1339.00
6.70	-0236C	1442.00
6.80	-0236E	1545.00
6.90	-0236G	1442.00
7.00	-0236J	2163.00
7.10	-0236L	2266.00
7.20	-0236N	2292.00
7.30	-0236Q	2369.00
7.40	-0236S	2472.00
7.50	-0236V	2266.00
7.60	-0236X	2472.00
7.70	-0236Z	2575.00
7.80	-0237B	2678.00
7.90	-0237D	2730.00
8.00	-0237F	2575.00
8.10	-0237H	2781.00
8.20	-0237K	2678.00
8.30	-0237M	2833.00
8.40	-0237P	2884.00
8.50	-0237R	2678.00
8.60	-0237T	3039.00
8.70	-0237W	3039.00
8.80	-0237Y	3193.00
8.90	-0237Z	3296.00
9.00	-0238A	2781.00
9.10	-0238B	2884.00
9.20	-0238C	2987.00
9.30	-0238G	3039.00
9.40	-0238H	3089.00
9.50	-0238L	3039.00
9.60	-0238N	3399.00
9.70	-0238P	3399.00
9.80	-0238Q	3399.00
9.90	-0238R	3502.00
10.00	-0238X	3193.00

Series J100 - Inch		PRICED PER 10
Dia. (mm)	Order Code SHR-025	Price/10 TB
10.10	-0238Y	3760.00
10.20	-0239B	3760.00
10.50	-0239H	3399.00
10.70	-0239L	4635.00
10.80	-0239M	4635.00
10.90	-0239N	4532.00
11.00	-0239T	4223.00
11.20	-0239W	5150.00
11.40	-0239Y	5665.00
11.50	-0239Z	5150.00
11.80	-0240C	5923.00
12.00	-0240E	5408.00
12.10	-0240F	7725.00
12.20	-0240G	7725.00
12.30	-0240H	7674.00
12.40	-0240J	7725.00
12.50	-0240K	5665.00
12.70	-0240M	6953.00
12.90	-0240P	7880.00
13.00	-0240R	6026.00
13.20	-0240T	1288.00
13.70	-0240Z	1545.00
13.80	-0241A	1545.00
14.00	-0241C	1236.00
14.25	-0241D	1339.00
14.50	-0241E	1442.00
14.75	-0241F	1751.00
15.00	-0241G	1597.00
15.25	-0241H	2215.00
15.50	-0241J	1751.00
15.75	-0241K	2369.00
16.00	-0241L	1957.00
16.50	-0241P	2112.00
17.00	-0241R	2059.00
17.50	-0241T	2421.00
18.00	-0241V	2678.00
18.50	-0241X	2781.00
19.00	-0241Z	2730.00
20.00	-0242D	3296.00

Series J100 - Inch		PRICED PER 10
Dia. (inch)	Order Code SHR-025	Price/10 TB
1/32"	-0243B	588.00
1/16"	-0243D	402.00
5/64"	-0243E	474.00
3/32"	-0243F	392.00
7/64"	-0243G	392.00
1/8"	-0243H	382.00
9/64"	-0243J	474.00
5/32"	-0243K	464.00
11/64"	-0243L	577.00
3/16"	-0243M	577.00
13/64"	-0243N	701.00
7/32"	-0243P	721.00
15/64"	-0243Q	1009.00
1/4"	-0243R	938.00
17/64"	-0243S	1167.00
9/32"	-0243T	1518.00
19/64"	-0243V	1518.00
5/16"	-0243W	1518.00
21/64"	-0243X	1858.00
11/32"	-0243Y	1858.00
23/64"	-0243Z	2250.00
3/8"	-0244A	2575.00
25/64"	-0244B	2833.00
13/32"	-0244C	2884.00
7/16"	-0244E	3502.00
29/64"	-0244F	3399.00
1/2"	-0244J	4635.00

HSS Jobber Drill Set - Bright Finish

Industrial quality. Ground flute. Supplied in indexing metal cases. Manufactured to **BS328 : Part 1 : 1986, DIN 338N & ANSI B94 - 11M.**

25 PIECES

x 0.5mm
1.0 ~ 13.0

(mm)	2.5	4.5	6.5	8.5	10.5	12.5
	3.0	5.0	7.0	9.0	11.0	13.0
	1.5	3.5	5.5	7.5	9.5	11.5
	2.0	4.0	6.0	8.0	10.0	12.0

Number of Pieces	Weight each	Order Code SHR-025	Price/1 TB
25		-8520K	4635.00

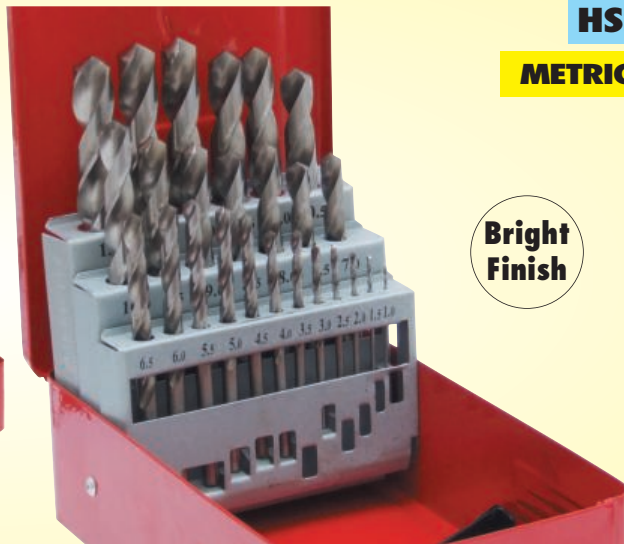

HSS

METRIC

Bright Finish

GROUP 025 DRILL SETS



HSS Jobber Drill Sets

Industrial quality. Ground flute, blue finish. Supplied in indexing metal cases. Manufactured to **BS328 : Part 1 DIN 338N & ANSI B94 - 11M.**

25 PIECES

DIN 338 For Dimensions
BS 328 See Pages 32 - 33

BEST SELLER



x 0.5mm
1.0 ~ 13.0

(mm)	2.5	4.5	6.5	8.5	10.5	12.5
1.0	3.0	5.0	7.0	9.0	11.0	13.0
1.5	3.5	5.5	7.5	9.5	11.5	
2.0	4.0	6.0	8.0	10.0	12.0	

Number of Pieces	Order Code SHR-025	Price/1 TB
25	-8500K	3760.00

HSS Ground Flute Select-A-Drill Set

HSS Ground Flute jobber drills in a 'Dial-a-Drill' style case. With a clear top to view drills. Manufactured to **BS328 DIN 338N & ANSI B94 - 11M.**

19 PIECES



BEST SELLER

x 0.5mm
1.0 ~ 10.0

(mm)	2.0	3.5	5.0	6.5	8.0	9.5
1.0	2.5	4.0	5.5	7.0	8.5	10.0
1.5	3.0	4.5	6.0	7.5	9.0	

Number of Pieces	Order Code SHR-025	Price/1 TB
19	-9000K	2678.00

HSS Ground Flute Tap & Drill Set

Industrial quality. Ground flute, blue finish. Supplied in indexing metal cases. Manufactured to **BS328 : Part 1 : 1986, DIN 338N & ANSI B94 -11M.**

19 PIECES

28 PIECES



METRIC Taps M3 ~ M12 +Tapping Drills **2.5 ~ 10.2**

28 Piece Tap & Drill Set
Taps (Taper, Second and Bottom)

M3	M5	M8	M12
M4	M6	M10	

Tapping Drills			
(mm)	3.3	5.0	8.5
2.5	4.2	6.8	10.2
Number of Pieces	Order Code SHR-025	Price/1 TB	
28	-9960K	8755.00	

24 Piece Tap & Drill Sets

Industrial Quality
Ground flute, blue finish. Supplied in indexing metal cases. Manufactured to **BS328 : Part 1 : 1986, DIN 338N & ANSI B94 -11M.**

24 PIECES

24 Piece Tap & Drill Sets
Taps (Taper, Second and Bottom)



UNF Taps No10 ~ 1/2" +Tapping Drills **4.1 ~ 11.5**

No10	1/4"	5/16"	3/8"	7/16"	1/2"
------	------	-------	------	-------	------

Tapping Drills					
4.1	5.5	6.9	8.5	9.9	11.5

BSW Taps 3/16" ~ 1/2" +Tapping Drills **3.7 ~ 10.5**

3/16"	1/4"	5/16"	3/8"	7/16"	1/2"
-------	------	-------	------	-------	------

Tapping Drills					
3.7	5.1	6.5	7.9	9.3	10.5

UNC Taps No8 ~ 1/2" +Tapping Drills **3.5 ~ 10.28**

No8	No10	1/4"	5/16"	3/8"	1/2"
-----	------	------	-------	------	------

Tapping Drills					
3.5	3.9	5.1	6.6	8.0	10.8

Number of Pieces	Type	Order Code SHR-025	Price/1 TB
24	UNC (No.8 - 1/2")	-9970K	8755.00
	UNF (No.10 - 1/2")	-9980K	8755.00
	BSW (3/16" - 1/2")	-9990K	8755.00



51 PIECES

x 0.1mm
1.0 ~ 6.0

(mm)	1.6	2.3	3.0	3.7	4.4	5.1	5.8
1.0	1.7	2.4	3.1	3.8	4.5	5.2	5.9
1.1	1.8	2.5	3.2	3.9	4.6	5.3	6.0
1.2	1.9	2.6	3.3	4.0	4.7	5.4	
1.3	2.0	2.7	3.4	4.1	4.8	5.5	
1.4	2.1	2.8	3.5	4.2	4.9	5.6	
1.5	2.2	2.9	3.6	4.3	5.0	5.7	

Number of Pieces	Order Code SHR-025	Price/1 TB
51	-8380K	3760.00



19 PIECES

x 0.5mm
1.0 ~ 10.0

(mm)	2.0	3.5	5.0	6.5	8.0	9.5
1.0	2.5	4.0	5.5	7.0	8.5	10.0
1.5	3.0	4.5	6.0	7.5	9.0	

Number of Pieces	Order Code SHR-025	Price/1 TB
19	-8460K	2318.00



32 PIECES

x 0.5mm
1.0 ~ 10.5
+Tapping sizes **1.9 to 10.2**

(mm)	2.5	3.5	5.1	7.5	10.0
1.0	2.6	3.8	5.5	7.9	10.2
1.5	2.9	4.0	6.0	8.0	10.5
1.9	3.0	4.2	6.5	8.5	
2.0	3.2	4.5	6.8	9.0	
2.1	3.3	5.0	7.0	9.5	

Number of Pieces	Order Code SHR-025	Price/1 TB
32	-8470K	2575.00



41 PIECES

x 0.1mm
6.0 ~ 10.0

(mm)	6.5	7.1	7.7	8.3	8.9	9.5
6.0	6.6	7.2	7.8	8.4	9.0	9.6
6.1	6.7	7.3	7.9	8.5	9.1	9.7
6.2	6.8	7.4	8.0	8.6	9.2	9.8
6.3	6.9	7.5	8.1	8.7	9.3	9.9
6.4	7.0	7.6	8.2	8.8	9.4	10.0

Number of Pieces	Order Code SHR-025	Price/1 TB
41	-8420K	7983.00

SHERWOOD **HSS Ground Flute**
QUALITY CUTTING TOOLS **Jobber Drill Sets**

Industrial quality. Ground flute, blue finish. Supplied in indexing metal cases.
Manufactured to **BS328 : Part 1 : 1986, DIN 338N & ANSI B94 - 11M.**

DIN 338 For Dimensions
BS 328 See Pages 32 - 33



CUTTING TOOLS

7
PIECES



X 1/32"
1/16" ~ 1/4"

1/16" 3/32"	1/8" 5/32"	3/16" 7/32"	1/4"
Number of Pieces	Order Code	Price/1 TB	
7	SHR-025 -8890K	999.00	

29
PIECES



X 1/64"
1/16" ~ 1/2"

1/16" 5/64" 3/32" 7/64" 1/8" 9/64"	5/32" 11/64" 3/16" 13/64" 7/32" 15/64"	1/4" 17/64" 9/32" 19/64" 5/16" 21/64"	11/32" 23/64" 3/8" 25/64" 13/32" 27/64"	7/16" 29/64" 15/32" 31/64" 1/2"
Number of Pieces	Order Code	Price/1 TB		
29	SHR-025 -8800K	4893.00		

13
PIECES



X 1/64"
1/16" ~ 1/4"

1/16" 5/64" 3/32"	7/64" 1/8" 9/64"	5/32" 11/64" 3/16"	13/64" 7/32" 15/64"	1/4"
Number of Pieces	Order Code	Price/1 TB		
13	SHR-025 -8680K	1029.00		

15
PIECES



X 1/32"
1/16" ~ 1/2"

1/16" 3/32" 1/8"	5/32" 3/16" 7/32"	1/4" 9/32" 5/16"	11/32" 3/8" 13/32"	7/16" 15/32" 1/2"
Number of Pieces	Order Code	Price/1 TB		
15	SHR-025 -8840K	2936.00		

21
PIECES



X 1/64"
1/16" ~ 3/8"

1/16" 5/64" 3/32" 7/64"	1/8" 9/64" 5/32" 11/64"	3/16" 13/64" 7/32" 15/64"	1/4" 17/64" 9/32" 19/64"	5/16" 21/64" 11/32" 23/64"	3/8"
Number of Pieces	Order Code	Price/1 TB			
21	SHR-025 -8720K	2266.00			

Assorted Drill Set

100 Piece
Assorted inch and metric sizes up to 1/2" - 13mm.
Straight shank.
Supplied in a plastic case.
Set contents may vary.



NEW

100
PIECES



Number of Pieces	Order Code	Price/1 TB
100	PRO-025 -9002A	2999.00

60
PIECES



GAUGE
No.1 to 60
Inclusive

Number of Pieces	Order Code	Price/1 TB
60	SHR-025 -8880K	5923.00

114
PIECES

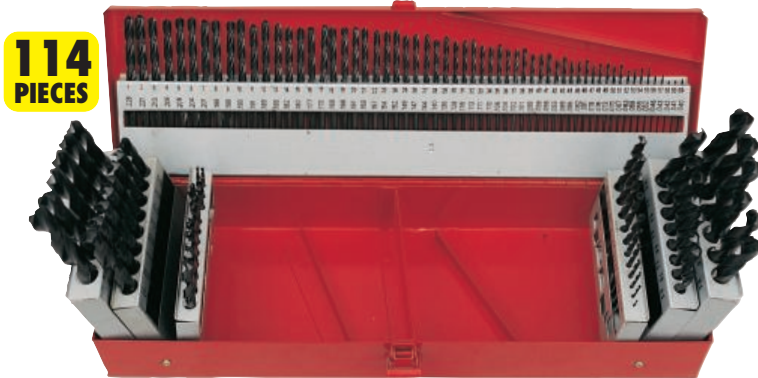

x 0.5mm
1.0 ~ 13.0

X 1/64"
1/16" ~ 1/2"

GAUGE
No.1 to 60
Inclusive

1/16" 5/64" 3/32" 7/64" 1/8" 9/64"	5/32" 11/64" 3/16" 13/64" 7/32" 15/64"	1/4" 17/64" 9/32" 19/64" 5/16" 21/64"	11/32" 23/64" 3/8" 25/64" 13/32" 27/64"	7/16" 29/64" 15/32" 31/64" 1/2"
Number of Pieces	Order Code	Price/1 TB		
114	SHR-025 -8920K	13030.00		

(mm)	2.5	4.5	6.5	8.5	10.5	12.5
1.0	3.0	5.0	7.0	9.0	11.0	13.0
1.5	3.5	5.5	7.5	9.5	11.5	
2.0	4.0	6.0	8.0	10.0	12.0	
Number of Pieces	Order Code	Price/1 TB				
114	SHR-025 -8920K	13030.00				

PRODUCTS ARE ONLY AVAILABLE VIA YOUR DISTRIBUTOR

SWISS+TECH *HSS Straight Shank TiN Tipped Jobber Drills*

Bright body with TiN coating on working part. For drilling in steel, cast steel alloyed and non-alloyed, grey cast iron, graphite and malleable cast iron. Point angle: 118°, helix angle: normal, web thickness: standard, relief angle: normal, tolerance of diameter: h8, tolerance of shank: f11. Manufactured to **BS 328, DIN 338**.



HSS TiN-tip

DIN 338 For Dimensions
BS 328 See Pages 32 - 33



DIN 1412A 118°

Series 1004 - Metric

Dia. (mm)	Order Code SWT-125	Price/1 TB	Dia. (mm)	Order Code SWT-125	Price/1 TB
1.00	-5010A	208.00	5.30	-5053A	213.00
1.10	-5011A	208.00	5.40	-5054A	213.00
1.20	-5012A	191.00	5.50	-5055A	213.00
1.30	-5013A	191.00	5.60	-5056A	213.00
1.40	-5014A	191.00	5.70	-5057A	213.00
1.50	-5015A	191.00	5.80	-5058A	213.00
1.60	-5016A	191.00	5.90	-5059A	213.00
1.70	-5017A	191.00	6.00	-5060A	213.00
1.80	-5018A	191.00	6.10	-5061A	213.00
1.90	-5019A	191.00	6.20	-5062A	213.00
2.00	-5020A	185.00	6.30	-5063A	213.00
2.10	-5021A	185.00	6.40	-5064A	213.00
2.20	-5022A	185.00	6.50	-5065A	339.00
2.30	-5023A	185.00	6.60	-5066A	339.00
2.40	-5024A	185.00	6.70	-5067A	339.00
2.50	-5025A	185.00	6.80	-5068A	339.00
2.60	-5026A	185.00	6.90	-5069A	339.00
2.70	-5027A	185.00	7.00	-5070A	353.00
2.80	-5028A	185.00	7.10	-5071A	353.00
2.90	-5029A	185.00	7.20	-5072A	353.00
3.00	-5030A	191.00	7.50	-5075A	353.00
3.10	-5031A	191.00	7.80	-5078A	353.00
3.20	-5032A	191.00	8.00	-5080A	389.00
3.30	-5033A	191.00	8.10	-5081A	403.00
3.40	-5034A	191.00	8.20	-5082A	403.00
3.50	-5035A	191.00	8.30	-5083A	403.00
3.60	-5036A	191.00	8.40	-5084A	403.00
3.70	-5037A	191.00	8.50	-5085A	403.00
3.80	-5038A	191.00	8.60	-5086A	403.00
3.90	-5039A	191.00	8.70	-5087A	403.00
4.00	-5040A	197.00	8.80	-5088A	403.00
4.10	-5041A	197.00	9.00	-5090A	419.00
4.20	-5042A	197.00	9.10	-5091A	419.00
4.30	-5043A	197.00	9.20	-5092A	419.00
4.40	-5044A	197.00	9.50	-5095A	499.00
4.50	-5045A	203.00	9.60	-5096A	499.00
4.60	-5046A	203.00	9.80	-5098A	525.00
4.70	-5047A	203.00	10.00	-5100A	525.00
4.80	-5048A	203.00	10.20	-5102A	525.00
4.90	-5049A	203.00	10.30	-5103A	558.00
5.00	-5050A	213.00	10.40	-5104A	558.00
5.10	-5051A	213.00	10.50	-5105A	558.00
5.20	-5052A	213.00	10.80	-5108A	558.00

Inch Sizes

Dia. (inch)	Order Code SWT-125	Price/1 TB
1/16"	-5002A	158.00
3/32"	-5002L	191.00
1/8"	-5003A	191.00
9/64"	-5003L	224.00
5/32"	-5004A	196.00
3/16"	-5004L	208.00
7/32"	-5005A	224.00
1/4"	-5005L	336.00
3/8"	-5007A	504.00
1/2"	-5008A	710.00

HSS TiN Tipped Jobber Drill Sets

19 & 25 Piece Metric Sets

x 0.5mm
1.0 ~ 10.0

19 PIECES

x 0.5mm
1.0 ~ 13.0

25 PIECES

Number of Pieces	Order Code SWT-125	Price/1 TB
19	-9010A	4119.00
25	-9020A	5149.00

HSS TiN Coated Jobber Drills

General purpose drill, to drill steels with a tensile strength up to 1,000N/mm², cast steel, grey cast iron, malleable cast iron, nickel brass and graphite. TiN coating provides longer tool life. Point angle: 118°, helix angle: normal, web thickness: normal, relief angle: normal, tolerance of diameter: h8, tolerance of shank: f11. Manufactured to **DIN 338 RN, DIN 338**.

HSS TiN

DIN 338 For Dimensions
BS 328 See Pages 32 - 33



DIN 1412A 118°

Series 1001 - Metric

Dia. (mm)	Order Code SWT-125	Price/1 TB	Dia. (mm)	Order Code SWT-125	Price/1 TB	Dia. (mm)	Order Code SWT-125	Price/1 TB
1.00	-0010A	208.00	3.50	-0035A	191.00	6.50	-0065A	339.00
1.50	-0015A	191.00	4.00	-0040A	196.00	6.80	-0068A	339.00
1.60	-0016A	191.00	4.20	-0042A	203.00	7.00	-0070A	339.00
2.00	-0020A	185.00	4.50	-0045A	203.00	7.50	-0075A	339.00
2.50	-0025A	185.00	5.00	-0050A	213.00	7.80	-0078A	384.00
3.00	-0030A	191.00	5.50	-0055A	213.00	8.00	-0080A	493.00
3.10	-0031A	191.00	6.00	-0060A	230.00	8.50	-0085A	520.00
3.20	-0032A	191.00	6.10	-0061A	274.00	9.00	-0090A	603.00
3.30	-0033A	191.00	6.20	-0062A	339.00	9.50	-0095A	641.00
						10.00	-0100A	657.00
						10.20	-0102A	684.00
						10.50	-0105A	712.00
						11.00	-0110A	738.00
						11.50	-0115A	750.00
						12.00	-0120A	794.00
						12.50	-0125A	875.00
						13.00	-0130A	776.00



HSS-Co Straight Shank Heavy Duty Drills

The addition of up to 8% cobalt allows higher speeds to be used without reducing the life of the tool, increasing productivity. 28° helix and 135° point. Manufactured to **DIN 338 RN**.



For Dimensions



See Pages 32 - 33



HSS-Co



DIN 1412C 135°

Series 1020 - Metric

Dia. (mm)	Order Code SWT-125	Price/1 TB	Dia. (mm)	Order Code SWT-125	Price/1 TB	Dia. (mm)	Order Code SWT-125	Price/1 TB	Dia. (mm)	Order Code SWT-125	Price/1 TB
1.00	-0410A	274.00	3.00	-0430A	329.00	5.30	-0453A	493.00	9.00	-0490A	603.00
1.10	-0411A	274.00	3.10	-0431A	329.00	5.50	-0455A	493.00	9.50	-0495A	657.00
1.20	-0412A	274.00	3.20	-0432A	329.00	5.80	-0458A	493.00	9.60	-0496A	1751.00
1.40	-0414A	274.00	3.30	-0433A	329.00	5.90	-0459A	493.00	9.70	-0497A	733.00
1.50	-0415A	274.00	3.40	-0434A	329.00	6.00	-0460A	493.00	10.00	-0500A	733.00
1.60	-0416A	274.00	3.50	-0435A	438.00	6.20	-0462A	743.00	10.20	-0502A	821.00
1.70	-0417A	274.00	3.70	-0437A	438.00	6.40	-0464A	493.00	10.40	-0504A	821.00
1.80	-0418A	274.00	3.80	-0438A	438.00	6.50	-0465A	493.00	10.50	-0505A	821.00
1.90	-0419A	274.00	4.00	-0440A	438.00	6.70	-0467A	493.00	11.00	-0510A	918.00
2.00	-0420A	274.00	4.10	-0441A	438.00	6.80	-0468A	493.00	10.80	-0508A	2282.00
2.10	-0421A	274.00	4.20	-0442A	438.00	7.00	-0470A	493.00	11.50	-0515A	984.00
2.20	-0422A	274.00	4.30	-0443A	438.00	7.10	-0471A	1009.00	11.80	-0518A	1072.00
2.40	-0424A	274.00	4.50	-0445A	438.00	7.20	-0472A	493.00	12.00	-0520A	1072.00
2.50	-0425A	274.00	4.80	-0448A	493.00	7.50	-0475A	493.00	12.50	-0525A	1159.00
2.60	-0426A	329.00	4.90	-0449A	493.00	8.00	-0480A	520.00	13.00	-0530A	1203.00
2.70	-0427A	329.00	5.00	-0450A	493.00	8.20	-0482A	531.00	13.50	-0535A	4934.00
2.80	-0428A	329.00	5.10	-0451A	493.00	8.30	-0483A	575.00	14.00	-0540A	4987.00
2.90	-0429A	329.00	5.20	-0452A	493.00	8.50	-0485A	586.00			

HSS-Co Straight Shank Heavy Duty TiN Tipped Drills

Heavy-duty drill used to drill steels with a tensile strength up to 1,400 N/mm². Stainless steels, heat and acid resistant steels and phosphor bronze. TiN coating provides longer tool life. Point angle: 135°. Helix angle: normal. Web thickness: strengthened. Relief angle: normal. Tolerance of diameter: h8. Supply unit. All diameters - 1 pce. Manufactured to **DIN 338 RN**.

HSS-Co TiN-tip



For Dimensions



See Pages 32 - 33



DIN 1412A 135°

Series 1024 - Metric

Dia. (mm)	Order Code SWT-125	Price/1 TB	Dia. (mm)	Order Code SWT-125	Price/1 TB	Dia. (mm)	Order Code SWT-125	Price/1 TB	Dia. (mm)	Order Code SWT-125	Price/1 TB
1.00	-1710A	335.00	3.50	-1735A	531.00	6.50	-1765A	600.00	10.50	-1805A	1009.00
1.50	-1715A	335.00	4.00	-1740A	531.00	6.80	-1768A	600.00	11.00	-1810A	1115.00
1.60	-1716A	335.00	4.20	-1742A	531.00	7.00	-1770A	600.00	12.00	-1820A	1300.00
2.00	-1720A	335.00	4.50	-1745A	531.00	7.50	-1775A	600.00	12.50	-1825A	1406.00
2.50	-1725A	335.00	4.90	-1749A	600.00	8.00	-1780A	632.00	13.00	-1830A	1460.00
3.00	-1730A	399.00	5.00	-1750A	600.00	8.50	-1785A	632.00			
3.20	-1732A	399.00	5.50	-1755A	600.00	9.00	-1790A	728.00			
3.30	-1733A	399.00	6.00	-1760A	600.00	10.00	-1800A	903.00			

HSS-Co Straight Shank Heavy Duty TiN Coated Drills

Heavy-duty drill used to drill steels with a tensile strength up to 1,400 N/mm². Stainless steels, heat and acid resistant steels and phosphor bronze. TiN coating provides longer tool life. Point angle: 135°. Helix angle: normal. Web thickness: strengthened. Relief angle: normal. Tolerance of diameter: h8. Supply unit. All diameters - 1 pce. Manufactured to **DIN 338 RN**.

HSS-Co TiN



For Dimensions



See Pages 32 - 33



DIN 1412C 135°

Series 1033 - Metric

Dia. (mm)	Order Code SWT-125	Price/1 TB	Dia. (mm)	Order Code SWT-125	Price/1 TB	Dia. (mm)	Order Code SWT-125	Price/1 TB	Dia. (mm)	Order Code SWT-125	Price/1 TB
1.00	-0610A	329.00	2.70	-0627A	329.00	5.00	-0650A	547.00	8.20	-0682A	755.00
1.10	-0611A	329.00	2.80	-0628A	329.00	5.10	-0651A	547.00	8.50	-0685A	974.00
1.20	-0612A	329.00	3.00	-0630A	329.00	5.20	-0652A	547.00	8.70	-0687A	821.00
1.40	-0614A	329.00	3.20	-0632A	329.00	5.50	-0655A	547.00	9.00	-0690A	766.00
1.50	-0615A	329.00	3.30	-0633A	329.00	5.80	-0658A	603.00	9.50	-0695A	865.00
1.60	-0616A	329.00	3.40	-0634A	329.00	6.00	-0660A	603.00	9.70	-0697A	875.00
1.70	-0617A	329.00	3.50	-0635A	329.00	6.10	-0661A	603.00	10.00	-0700A	875.00
1.80	-0618A	329.00	3.90	-0639A	438.00	6.20	-0662A	603.00	10.20	-0702A	1028.00
2.00	-0620A	329.00	4.00	-0640A	438.00	6.30	-0663A	603.00	11.00	-0710A	1367.00
2.10	-0621A	329.00	4.10	-0641A	438.00	6.50	-0665A	634.00	12.00	-0720A	1498.00
2.20	-0622A	329.00	4.20	-0642A	493.00	6.80	-0668A	634.00	12.50	-0725A	1159.00
2.30	-0623A	329.00	4.30	-0643A	547.00	6.90	-0669A	634.00	13.00	-0730A	1793.00
2.40	-0624A	329.00	4.50	-0645A	547.00	7.00	-0670A	624.00			
2.50	-0625A	329.00	4.80	-0648A	547.00	7.50	-0675A	898.00			
2.60	-0626A	329.00	4.90	-0649A	547.00	8.00	-0680A	908.00			

SWISS+TECH *HSS-Co Straight Shank High Helix Drills*

High helix drills, to drill long-chipping materials like aluminium, aluminium alloys, copper and plastics. Point angle: 130°. Helix angle: high. Web thickness: normal. Relief angle: normal. Tolerance of diameter: h8. Tolerance of shank: f11. Manufactured to **DIN 338 RN**.



HSS-Co

DIN 338 For Dimensions
BS 328 See Pages 32 - 33



DIN 1412C 130°

Series 1012 - Metric

Dia. (mm)	Order Code SWT-125	Price/1 TB	Dia. (mm)	Order Code SWT-125	Price/1 TB	Dia. (mm)	Order Code SWT-125	Price/1 TB	Dia. (mm)	Order Code SWT-125	Price/1 TB
2.50	-0225A	416.00	4.00	-0240A	493.00	6.00	-0260A	679.00	10.50	-0305A	2110.00
3.00	-0230A	362.00	4.20	-0242A	591.00	6.50	-0265A	984.00	12.00	-0320A	2558.00
3.30	-0233A	395.00	4.50	-0245A	624.00	7.00	-0270A	1060.00	13.00	-0330A	3104.00
3.50	-0235A	460.00	5.00	-0250A	690.00	10.00	-0300A	1826.00			

HSS-Co Straight Shank TiN Tipped High Helix Drills

Heavy duty drill for stainless steel, heat and acid-resistant steels, short chipping and high strength steels. High heat resistance allows drilling in titanium and titanium alloys. TiN coating provides longer tool life. Point angle: 130°. Helix angle: high. Web thickness: strengthened. Relief angle: normal. Tolerance of diameter: h8. Tolerance of shank: f11. Supply unit. All diameters - 1 pce. Manufactured to **DIN 338RN**.

HSS-Co TiN-tip

DIN 338 For Dimensions
BS 328 See Pages 32 - 33



DIN 1412C 130°

Series 1014 - Metric

Dia. (mm)	Order Code SWT-125	Price/1 TB	Dia. (mm)	Order Code SWT-125	Price/1 TB	Dia. (mm)	Order Code SWT-125	Price/1 TB	Dia. (mm)	Order Code SWT-125	Price/1 TB
2.00	-1420A	505.00	4.20	-1442A	717.00	7.00	-1570A	1290.00	11.00	-1610A	2600.00
2.50	-1425A	505.00	4.50	-1450A	760.00	8.00	-1580A	1433.00	12.00	-1612A	3104.00
3.00	-1430A	505.00	5.00	-1500A	834.00	8.50	-1585A	1539.00	13.00	-1613A	3767.00
3.30	-1433A	505.00	5.20	-1520A	955.00	9.00	-1590A	1751.00			
3.50	-1435A	558.00	5.50	-1550A	955.00	10.00	-1600A	2121.00			
4.00	-1440A	600.00	6.00	-1560A	982.00	10.50	-1605A	2547.00			

HSS-Co Straight Shank TiN Coated High Helix Drills

Heavy duty drill for stainless steel, heat and acid-resistant steels, short chipping and high strength steels. High heat resistance allows drilling in titanium and titanium alloys. TiN coating provides longer tool life. Point angle: 130°. Helix angle: high. Web thickness: strengthened. Relief angle: normal. Tolerance of diameter: h8. Tolerance of shank: f11. Supply unit. All diameters - 1 pce. Manufactured to **DIN 338RN**.

HSS-Co TiN

DIN 338 For Dimensions
BS 328 See Pages 32 - 33



DIN 1412C 130°

Series 1060 - Metric

Dia. (mm)	Order Code SWT-125	Price/1 TB	Dia. (mm)	Order Code SWT-125	Price/1 TB	Dia. (mm)	Order Code SWT-125	Price/1 TB	Dia. (mm)	Order Code SWT-125	Price/1 TB
2.00	-1220A	422.00	4.20	-1242A	662.00	6.00	-1260A	969.00	9.00	-1290A	1925.00
2.50	-1225A	542.00	4.50	-1245A	723.00	6.50	-1265A	1115.00	10.00	-1300A	2224.00
3.00	-1230A	422.00	4.80	-1248A	738.00	7.00	-1270A	1143.00	10.50	-1305A	3307.00
3.30	-1233A	603.00	5.00	-1250A	723.00	7.50	-1275A	1263.00	11.00	-1310A	3667.00
3.50	-1235A	603.00	5.20	-1252A	795.00	8.00	-1280A	1444.00	12.00	-1320A	5055.00
4.00	-1240A	662.00	5.50	-1255A	903.00	8.50	-1285A	1503.00	13.00	-1330A	5055.00

KENNEDY *HSS-Co Straight Shank Drills*
QUALITY INDUSTRIAL TOOLING®

Heavy duty drill made of cobalt material with excellent heat resistance. To drill steels with tensile strength up to 1,400 N/mm², very hard bronze, stainless steels as well as heat and acid resistant steels. Point angle: 135°. Helix angle: normal. Web thickness: strengthened. Relief angle: normal. Tolerance of diameter: h8. Tolerance of shank: f11. Supply unit. All diameters - 1 pce. Manufacturing to **BS 328, DIN 338B**.



DIN 338 For Dimensions
BS 328 See Pages 32 - 33



Metric

Dia. (mm)	Order Code KEN-026	Price/1 TB	Dia. (mm)	Order Code KEN-026	Price/1 TB
1.00	-0200K	124.00	4.80	-0960K	372.00
1.10	-0220K	124.00	4.90	-0980K	377.00
1.20	-0240K	124.00	5.00	-1000K	273.00
1.30	-0260K	124.00	5.10	-1020K	372.00
1.40	-0280K	124.00	5.20	-1040K	398.00
1.50	-0300K	103.00	5.30	-1060K	398.00
1.60	-0320K	124.00	5.40	-1080K	514.00
1.70	-0340K	124.00	5.50	-1100K	464.00
1.80	-0360K	124.00	5.60	-1120K	478.00
1.90	-0380K	124.00	5.70	-1140K	484.00
2.00	-0400K	160.00	5.80	-1160K	494.00
2.10	-0420K	134.00	5.90	-1180K	567.00
2.20	-0440K	134.00	6.00	-1200K	319.00
2.30	-0460K	134.00	6.10	-1220K	541.00
2.40	-0480K	134.00	6.20	-1240K	546.00
2.50	-0500K	170.00	6.30	-1260K	600.00
2.60	-0520K	145.00	6.40	-1280K	644.00
2.70	-0540K	145.00	6.50	-1300K	618.00
2.80	-0560K	145.00	6.60	-1320K	644.00
3.00	-0600K	165.00	6.70	-1340K	670.00
3.10	-0620K	176.00	6.80	-1360K	696.00
3.20	-0640K	266.00	7.00	-1400K	425.00
3.30	-0660K	176.00	7.20	-1440K	743.00
3.40	-0680K	217.00	7.50	-1500K	531.00
3.50	-0700K	196.00	7.70	-1540K	797.00
3.60	-0720K	299.00	8.00	-1600K	585.00
3.70	-0740K	320.00	8.50	-1700K	637.00
3.80	-0760K	320.00	9.00	-1800K	743.00
3.90	-0780K	320.00	9.50	-1900K	797.00
4.00	-0800K	196.00	10.00	-2000K	903.00
4.10	-0820K	334.00	10.20	-2040K	1433.00
4.20	-0840K	314.00	10.50	-2100K	1433.00
4.30	-0860K	334.00	11.00	-2200K	1115.00
4.40	-0880K	411.00	11.50	-2300K	1804.00
4.50	-0900K	232.00	12.00	-2400K	1380.00
4.60	-0920K	372.00	12.50	-2500K	2176.00
4.70	-0940K	372.00	13.00	-2600K	2176.00

HSS-Co Straight Shank Drill Sets

Inch & Metric Sets
 Straight Shank.
 Manufactured to **BS 328, DIN 338B**.

19 PIECES **EXTENDED RANGE**

x 0.5mm
1.0 ~ 10.0

x 1/32"
1/16" ~ 1/2"

15 PIECES

Type	Number of Pieces	Order Code KEN-026	Price/1 TB
Metric	19	-8460K	5665.00
Inch	15	-8490K	6179.00

Inch

Dia. (inch)	Order Code KEN-026	Price/1 TB	Dia. (inch)	Order Code KEN-026	Price/1 TB
1/16"	-3040K	201.00	7/32"	-3140K	387.00
3/32"	-3060K	191.00	1/4"	-3160K	411.00
7/64"	-3070K	191.00	17/64"	-3170K	617.00
1/8"	-3080K	196.00	9/32"	-3180K	670.00
9/64"	-3090K	232.00	5/16"	-3200K	824.00
5/32"	-3100K	237.00	11/32"	-3220K	1133.00
11/64"	-3110K	335.00	3/8"	-3240K	849.00
3/16"	-3120K	351.00	1/2"	-3320K	2059.00

SHERWOOD *HSS Drill Blanks*
QUALITY CUTTING TOOLS

Jobber length blank hardened and ground all over. Accurately ground without back taper. Diameter tolerance: h8. Manufactured to **DIN 338**.

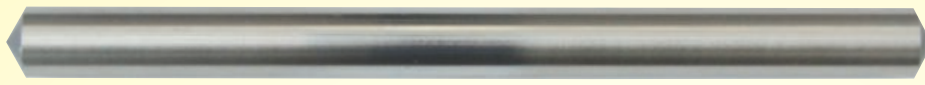

Series J400 - Metric

Dia. (mm)	Order Code SHR-024	Price/10 TB	Dia. (mm)	Order Code SHR-024	Price/10 TB	Dia. (mm)	Order Code SHR-024	Price/10 TB	Dia. (mm)	Order Code SHR-024	Price/10 TB
1.00	-2398F	242.00	3.50	-2444F	314.00	6.00	-2474N	683.00	8.50	-2504W	1313.00
1.10	-2400H	242.00	3.60	-2445G	314.00	6.10	-2475P	683.00	8.60	-2505X	1418.00
1.20	-2402K	242.00	3.70	-2446H	314.00	6.20	-2476Q	683.00	8.70	-2506Y	1418.00
1.30	-2404M	242.00	3.80	-2448K	314.00	6.30	-2478S	683.00	8.80	-2508A	1418.00
1.40	-2406P	242.00	3.90	-2449L	314.00	6.40	-2479T	683.00	8.90	-2509B	1418.00
1.50	-2408R	242.00	4.00	-2450M	350.00	6.50	-2480V	683.00	9.00	-2510C	1418.00
1.60	-2410T	242.00	4.10	-2451N	350.00	6.60	-2481W	893.00	9.10	-2511D	1575.00
1.70	-2412W	242.00	4.20	-2452P	350.00	6.70	-2482X	893.00	9.20	-2512E	1575.00
1.80	-2414Y	242.00	4.30	-2454R	350.00	6.80	-2484N	893.00	9.30	-2514G	1575.00
1.90	-2416A	242.00	4.40	-2455S	350.00	6.90	-2485A	893.00	9.40	-2515H	1575.00
2.00	-2418C	252.00	4.50	-2456T	350.00	7.00	-2486B	944.00	9.50	-2516J	1575.00
2.10	-2420E	252.00	4.60	-2457V	419.00	7.10	-2487C	944.00	9.60	-2517K	1680.00
2.20	-2422G	252.00	4.70	-2458W	419.00	7.20	-2488D	944.00	9.70	-2518L	1680.00
2.30	-2424J	252.00	4.80	-2460Y	419.00	7.30	-2490F	944.00	9.80	-2520N	1785.00
2.40	-2426L	252.00	4.90	-2461N	419.00	7.40	-2491G	1049.00	9.90	-2521P	1890.00
2.50	-2428N	252.00	5.00	-2462A	473.00	7.50	-2492H	1049.00	10.00	-2522Q	1995.00
2.60	-2430Q	252.00	5.10	-2463B	483.00	7.60	-2493J	1049.00	10.50	-2523R	2048.00
2.70	-2432S	252.00	5.20	-2464C	504.00	7.70	-2494K	1049.00	11.00	-2524S	2074.00
2.80	-2434V	252.00	5.30	-2466E	515.00	7.80	-2496M	1049.00	11.50	-2525T	2205.00
2.90	-2436X	252.00	5.40	-2467F	525.00	7.90	-2497N	1049.00	12.00	-2526V	2310.00
3.00	-2438N	314.00	5.50	-2468G	546.00	8.00	-2498P	1313.00	12.50	-2527W	2625.00
3.10	-2439A	314.00	5.60	-2469H	578.00	8.10	-2499Q	1313.00	13.00	-2528X	2625.00
3.20	-2440B	314.00	5.70	-2470J	578.00	8.20	-2500R	1313.00			
3.30	-2442D	314.00	5.80	-2472L	578.00	8.30	-2502T	1313.00			
3.40	-2443E	314.00	5.90	-2473M	683.00	8.40	-2503V	1313.00			

DIN 338 For Dimensions
BS 328 See Pages 32 - 33

PRODUCTS ARE ONLY AVAILABLE VIA YOUR DISTRIBUTOR

GROUP 025 STANDARD LENGTH DRILLS

SHERWOOD *Solid Carbide Jobber Drills*
 QUALITY CUTTING TOOLS

General purpose drills for drilling a wide variety of metallic and non-metallic materials.
 Point angle: 118°. Tolerance of diameter: h7. Tolerance of shank: h6. Supply unit. All diameters - 1 pce.
 Manufacturing Standard: **BS 328, DIN 338.**



CARBIDE

CUTTING TOOLS



DIN 338 For Dimensions
BS 328 See Pages 32 - 33

Series J102 - Metric

Dia. (mm)	Order Code SHR-158	Price/1 TB	Dia. (mm)	Order Code SHR-158	Price/1 TB	Dia. (mm)	Order Code SHR-158	Price/1 TB	Dia. (mm)	Order Code SHR-158	Price/1 TB
1.00	-5100K	332.00	3.90	-5390K	677.00	6.80	-5680K	1393.00	9.70	-5970K	3449.00
1.10	-5110K	332.00	4.00	-5400K	697.00	6.90	-5690K	1592.00	9.80	-5980K	3449.00
1.20	-5120K	332.00	4.10	-5410K	704.00	7.00	-5700K	1659.00	9.90	-5990K	3449.00
1.30	-5130K	332.00	4.20	-5420K	716.00	7.10	-5710K	1792.00	10.00	-6000K	2984.00
1.40	-5140K	332.00	4.30	-5430K	716.00	7.20	-5720K	1924.00	10.20	-6020K	3648.00
1.50	-5150K	332.00	4.40	-5440K	716.00	7.30	-5730K	1924.00	10.30	-6030K	3781.00
1.60	-5160K	332.00	4.50	-5450K	737.00	7.40	-5740K	1983.00	10.40	-6040K	3781.00
1.70	-5170K	332.00	4.60	-5460K	737.00	7.50	-5750K	1858.00	10.50	-6050K	3449.00
1.80	-5180K	332.00	4.70	-5470K	797.00	7.60	-5760K	1989.00	10.80	-6080K	4311.00
1.90	-5190K	332.00	4.80	-5480K	810.00	7.70	-5770K	1989.00	11.00	-6100K	3863.00
2.00	-5200K	332.00	4.90	-5490K	896.00	7.80	-5780K	1989.00	11.20	-6120K	4311.00
2.10	-5210K	398.00	5.00	-5500K	863.00	7.90	-5790K	1989.00	11.50	-6150K	4311.00
2.20	-5220K	398.00	5.10	-5510K	903.00	8.00	-5800K	1989.00	11.80	-6180K	4642.00
2.30	-5230K	398.00	5.20	-5520K	922.00	8.10	-5810K	2189.00	11.90	-6190K	4642.00
2.40	-5240K	419.00	5.30	-5530K	1028.00	8.20	-5820K	2255.00	12.00	-6200K	3515.00
2.50	-5250K	419.00	5.40	-5540K	1035.00	8.30	-5830K	2255.00	12.50	-6250K	3979.00
2.60	-5260K	438.00	5.50	-5550K	1055.00	8.40	-5840K	2255.00	12.70	-6270K	4244.00
2.70	-5270K	438.00	5.60	-5560K	1061.00	8.50	-5850K	1989.00	13.00	-6300K	4642.00
2.80	-5280K	438.00	5.70	-5570K	1188.00	8.60	-5860K	2255.00	13.50	-6350K	5149.00
2.90	-5290K	465.00	5.80	-5580K	1194.00	8.70	-5870K	2388.00	14.00	-6400K	5239.00
3.00	-5300K	498.00	5.90	-5590K	1208.00	8.80	-5880K	2520.00	15.00	-6500K	10279.00
3.10	-5310K	531.00	6.00	-5600K	1227.00	8.90	-5890K	2520.00	16.00	-6600K	11936.00
3.20	-5320K	544.00	6.10	-5610K	1227.00	9.00	-5900K	2122.00	17.00	-6700K	13527.00
3.30	-5330K	564.00	6.20	-5620K	1261.00	9.10	-5910K	2534.00	18.00	-6800K	15914.00
3.40	-5340K	564.00	6.30	-5630K	1294.00	9.20	-5920K	2653.00	19.00	-6900K	16577.00
3.50	-5350K	564.00	6.40	-5640K	1307.00	9.30	-5930K	2653.00	20.00	-7000K	18566.00
3.60	-5360K	577.00	6.50	-5650K	1261.00	9.40	-5940K	2653.00			
3.70	-5370K	598.00	6.60	-5660K	1325.00	9.50	-5950K	3050.00			
3.80	-5380K	664.00	6.70	-5670K	1393.00	9.60	-5960K	3131.00			

SWISS+TECH *Solid Carbide Q-Coat Drill*

For drilling into general steel, cast steel, cast iron, chilled cast iron, malleable cast iron, non-ferrous heavy and light metal, and abrasive plastic, self-centring. 3 X D.
 Point angle: 140°, tolerance of diameter: m7, tolerance of shank: h6.
 Manufactured to **DIN 6537.**



CARBIDE

Q-Coat



DIN 6537 - Short
 3 X D Nominal

Diameter (mm)	Shank Diameter	Overall Length	Flute Length	Shank Length	Order Code SWT-158	Price/1 TB
3.00	6.0	62.0	20.0	36.0	-3530S	1494.00
3.20	6.0	62.0	20.0	36.0	-3532S	1494.00
3.30	6.0	62.0	20.0	36.0	-3533S	1494.00
3.50	6.0	62.0	20.0	36.0	-3535S	1494.00
4.20	6.0	66.0	24.0	36.0	-3542S	1494.00
4.50	6.0	66.0	24.0	36.0	-3545S	1494.00
5.00	6.0	66.0	28.0	36.0	-3550S	1494.00
5.50	6.0	66.0	28.0	36.0	-3555S	1494.00
6.00	6.0	66.0	28.0	36.0	-3560S	1494.00
6.80	8.0	79.0	34.0	36.0	-3568S	2575.00
7.00	8.0	79.0	34.0	36.0	-3570S	2369.00
7.50	8.0	79.0	41.0	36.0	-3575S	2472.00
8.00	8.0	79.0	41.0	36.0	-3580S	2472.00
8.50	10.0	89.0	47.0	40.0	-3585S	3089.00
9.00	10.0	89.0	47.0	40.0	-3590S	3089.00
10.00	10.0	89.0	47.0	40.0	-3600S	3089.00
10.20	12.0	102.0	55.0	45.0	-3602S	3399.00
10.50	12.0	102.0	55.0	45.0	-3605S	3760.00
11.00	12.0	102.0	55.0	45.0	-3610S	3760.00
12.00	12.0	102.0	55.0	45.0	-3620S	3760.00
12.50	14.0	107.0	60.0	45.0	-3625S	5923.00
13.00	14.0	107.0	60.0	45.0	-3630S	5923.00
13.50	14.0	107.0	60.0	45.0	-3635S	5995.00
14.00	14.0	107.0	60.0	45.0	-3640S	6896.00
16.00	16.0	115.0	65.0	48.0	-3660S	7468.00

KENNEDY *Solid Carbide Jobber Drills*
 QUALITY INDUSTRIAL TOOLING

For drilling steels, cast steels, cast iron, chilled cast iron, malleable cast iron, non-ferrous heavy and light metal and abrasive plastic.
 Point angle 118°. Tolerance of diameter: h7.
 Tolerance of shank: h6.
 Supply unit. All diameters - 1 pce.
 Manufacturing to **DIN 338, DIN338.**



CARBIDE

DIN 338 For Dimensions
BS 328 See Pages 32 - 33



Metric

Dia. (mm)	Order Code KEN-158	Price/1 TB	Dia. (mm)	Order Code KEN-158	Price/1 TB
1.00	-0100K	765.00	6.50	-0650K	2409.00
1.50	-0150K	765.00	6.80	-0680K	2685.00
1.60	-0160K	765.00	7.00	-0700K	2685.00
2.00	-0200K	817.00	7.50	-0750K	3045.00
2.50	-0250K	977.00	8.00	-0800K	3480.00
3.00	-0300K	1093.00	8.50	-0850K	3639.00
3.30	-0330K	1167.00	9.00	-0900K	3947.00
3.50	-0350K	1221.00	9.50	-0950K	4594.00
4.00	-0400K	1444.00	10.00	-1000K	5061.00
4.20	-0420K	1634.00	10.20	-1020K	5061.00
4.50	-0450K	1634.00	10.50	-1050K	5507.00
5.00	-0500K	1910.00	11.00	-1100K	6048.00
5.50	-0550K	1910.00	11.50	-1150K	6556.00
6.00	-0600K	2292.00	12.00	-1200K	6960.00



HSS Straight Shank Long Series Drills - Steam Tempered



HSS

General purpose drills to drill steels with tensile strength up to 1,000N/mm², cast steel, grey cast iron, malleable cast iron, nickel brass and graphite. Point angle: 118°, helix angle: normal, web thickness: normal, relief angle: 10° - 20°, tolerance of diameter: h8, tolerance of f11.

Manufactured to **BS 328; Part 1: 1986, DIN 340 RN, ISO 494.**



Series L100 - Metric

Dia. (mm)	Flute Length	Overall Length	Order Code SHR-025	Price/1 TB	Dia. (mm)	Flute Length	Overall Length	Order Code SHR-025	Price/1 TB	Dia. (mm)	Flute Length	Overall Length	Order Code SHR-025	Price/1 TB
1.00	33.0	56.0	-1420A	205.00	5.20	87.0	132.0	-1479P	186.00	10.20	121.0	184.0	-1539E	622.00
1.10	37.0	60.0	-1421B	205.00	5.30	87.0	132.0	-1481R	186.00	10.40	121.0	184.0	-1542H	632.00
1.20	41.0	65.0	-1422C	139.00	5.40	91.0	139.0	-1482S	191.00	10.50	121.0	184.0	-1543J	664.00
1.30	41.0	65.0	-1423D	139.00	5.50	91.0	139.0	-1483T	191.00	10.70	128.0	195.0	-1545L	691.00
1.40	45.0	70.0	-1424E	139.00	5.60	91.0	139.0	-1484V	197.00	10.80	128.0	195.0	-1547N	691.00
1.50	45.0	70.0	-1425F	139.00	5.70	91.0	139.0	-1485W	197.00	11.00	128.0	195.0	-1549Q	728.00
1.60	50.0	76.0	-1426G	226.00	5.80	91.0	139.0	-1487Y	197.00	11.50	128.0	195.0	-1555X	807.00
1.70	50.0	76.0	-1427H	217.00	5.90	91.0	139.0	-1488N	197.00	11.70	128.0	195.0	-1557N	834.00
1.80	53.0	80.0	-1429K	145.00	6.00	91.0	139.0	-1489A	218.00	11.80	128.0	195.0	-1559B	876.00
1.90	53.0	80.0	-1431M	145.00	6.10	97.0	148.0	-1490B	242.00	12.00	134.0	205.0	-1561D	891.00
2.00	56.0	85.0	-1433P	155.00	6.20	97.0	148.0	-1491C	242.00	12.20	134.0	205.0	-1563F	908.00
2.10	56.0	85.0	-1435R	160.00	6.30	97.0	148.0	-1493E	242.00	12.50	134.0	205.0	-1567K	982.00
2.20	59.0	90.0	-1437T	160.00	6.40	97.0	148.0	-1494F	242.00	12.70	134.0	205.0	-1569M	979.00
2.30	59.0	90.0	-1439V	165.00	6.50	97.0	148.0	-1495G	247.00	13.00	134.0	205.0	-1573R	1046.00
2.40	62.0	95.0	-1441Y	165.00	6.60	97.0	148.0	-1496H	274.00	13.50	140.0	214.0	-1578X	1906.00
2.50	62.0	95.0	-1443A	165.00	6.70	97.0	148.0	-1497J	274.00	14.00	140.0	214.0	-1583C	1257.00
2.60	62.0	95.0	-1445C	165.00	6.80	102.0	156.0	-1499L	282.00	14.50	144.0	220.0	-1585E	2256.00
2.70	66.0	100.0	-1447E	165.00	6.90	102.0	156.0	-1500M	282.00	15.00	144.0	220.0	-1587G	1623.00
2.80	66.0	100.0	-1449G	165.00	7.00	102.0	156.0	-1501N	287.00	15.50	149.0	227.0	-1589J	2658.00
2.90	66.0	100.0	-1451J	165.00	7.10	102.0	156.0	-1502P	292.00	16.00	149.0	227.0	-1591L	1906.00
3.00	66.0	100.0	-1453L	170.00	7.20	102.0	156.0	-1503Q	318.00	16.50	154.0	235.0	-1593N	3054.00
3.10	69.0	106.0	-1454M	170.00	7.30	120.0	156.0	-1505S	318.00	17.00	154.0	235.0	-1595Q	2189.00
3.20	69.0	106.0	-1455N	170.00	7.50	102.0	156.0	-1507V	319.00	17.50	158.0	241.0	-1597S	3513.00
3.25	69.0	106.0	-1456P	170.00	7.70	109.0	165.0	-1509X	346.00	18.00	158.0	241.0	-1599V	2498.00
3.30	69.0	106.0	-1457Q	170.00	7.80	109.0	165.0	-1511N	351.00	20.00	166.0	254.0	-1607D	3163.00
3.40	73.0	112.0	-1458R	170.00	7.90	109.0	165.0	-1512A	351.00					
3.50	73.0	112.0	-1459S	170.00	8.00	109.0	165.0	-1513B	367.00					
3.60	73.0	112.0	-1460T	170.00	8.10	109.0	165.0	-1514C	377.00					
3.70	73.0	112.0	-1461V	170.00	8.20	109.0	165.0	-1515D	388.00					
3.80	78.0	119.0	-1463X	170.00	8.30	109.0	165.0	-1517F	393.00					
3.90	78.0	119.0	-1464Y	170.00	8.40	109.0	165.0	-1518G	403.00					
4.00	78.0	119.0	-1465N	176.00	8.50	109.0	165.0	-1519H	412.00					
4.10	78.0	119.0	-1466A	176.00	8.60	115.0	175.0	-1520J	438.00					
4.20	78.0	119.0	-1467B	176.00	8.70	115.0	175.0	-1521K	443.00					
4.30	82.0	126.0	-1469D	176.00	8.80	115.0	175.0	-1523M	449.00					
4.40	82.0	126.0	-1470E	176.00	9.00	115.0	175.0	-1525P	462.00					
4.50	82.0	126.0	-1471F	176.00	9.20	115.0	175.0	-1527R	484.00					
4.60	82.0	126.0	-1472G	176.00	9.40	115.0	175.0	-1530V	509.00					
4.70	82.0	126.0	-1473H	176.00	9.50	115.0	175.0	-1531W	519.00					
4.80	87.0	132.0	-1475K	176.00	9.60	121.0	184.0	-1532X	526.00					
4.90	87.0	132.0	-1476L	176.00	9.80	121.0	184.0	-1535A	541.00					
5.00	87.0	132.0	-1477M	167.00	10.00	121.0	184.0	-1537C	585.00					
5.10	87.0	132.0	-1478N	176.00	10.10	121.0	184.0	-1538D	610.00					



HSS Long Series Drill Set

METRIC HSS

Used for deep hole drilling in most materials. (Not suitable for the drilling of holes in crankshafts.)
Manufactured to **BS 328 : Part 1 : 1986.**



**10
PIECES**

mm
2.0 ~ 10.0

2.0 x 85mm	4.0 x 119mm	8.0 x 165mm
2.5 x 95mm	4.5 x 126mm	
3.0 x 100mm	5.0 x 132mm	
3.5 x 112mm	6.0 x 139mm	

Number of Pieces	Order Code SHR-025	Price/1 TB
10	-8540K	1700.00

PRODUCTS ARE ONLY AVAILABLE VIA YOUR DISTRIBUTOR

GROUP 025 LONG SERIES DRILLS



HSS Straight Shank Long Series Drills

General purpose high speed steel long series drills are designed for deep hole drilling of most materials. The drill has the same diameter on both the fluted section and the shank. Manufactured to **BS 328; Part 1: 1986, DIN 340 RN, ISO 494.**



HSS

CUTTING TOOLS



Series L100 - Inch

Dia. (mm)	Flute Length	Overall Length	Order Code SHR-025	Price/1 TB	Dia. (mm)	Flute Length	Overall Length	Order Code SHR-025	Price/1 TB	Dia. (mm)	Flute Length	Overall Length	Order Code SHR-025	Price/1 TB
1/32"	1 1/16"	1 7/8"	-1404Z	258.00	11/64"	3 7/32"	4 31/32"	-1405J	140.00	21/64"	4 9/32"	6 1/2"	-1405V	410.00
3/64"	1 5/8"	2 9/16"	-1405A	258.00	3/16"	3 7/16"	5 3/16"	-1405K	155.00	11/32"	4 17/32"	6 7/8"	-1405W	418.00
1/16"	1 31/32"	3"	-1405B	109.00	13/64"	3 7/16"	5 3/16"	-1405L	179.00	3/8"	4 3/4"	7 1/4"	-1405Y	510.00
5/64"	2 7/32"	3 11/32"	-1405C	175.00	7/32"	3 19/32"	5 19/32"	-1405M	189.00	13/32"	4 3/4"	7 1/4"	-1406A	603.00
3/32"	2 7/16"	3 3/4"	-1405D	101.00	15/64"	3 19/32"	5 15/32"	-1405N	217.00	7/16"	5 1/32"	7 11/16"	-1406C	691.00
7/64"	2 19/32"	3 15/16"	-1405E	155.00	1/4"	3 13/16"	5 13/16"	-1405P	230.00	29/64"	5 1/32"	7 11/16"	-1406D	1236.00
1/8"	2 23/32"	4 3/16"	-1405F	111.00	17/64"	4"	6 1/8"	-1405Q	258.00	15/32"	5 9/32"	8 1/16"	-1406E	1200.00
9/64"	2 7/8"	4 1 3/32"	-1405G	117.00	9/32"	4"	6 1/8"	-1405R	287.00	1/2"	5 9/32"	8 1/16"	-1406G	994.00
5/32"	3 1/16"	4 11/16"	-1405H	128.00	5/16"	4 9/32"	6 1/2"	-1405T	346.00					

HSS Straight Shank Long Series Drills - Bright Finish

General purpose drills to drill steels with tensile strength up to 1,000N/mm², cast steel, grey cast iron, malleable cast iron, nickel brass and graphite. Point angle: 118°, helix angle: normal, web thickness: normal, relief angle: 10° - 20°, tolerance of diameter: h8, tolerance of f11. Manufactured to **BS 328; Part 1: 1986, DIN 340 RN, ISO 494.** Drills with a bright finish are supplied in the as-ground condition and such tools are used generally in the machining of non-ferrous materials.

HSS



Series L100B - Metric

Dia. (mm)	Flute Length	Overall Length	Order Code SHR-025	Price/1 TB	Dia. (mm)	Flute Length	Overall Length	Order Code SHR-025	Price/1 TB	Dia. (mm)	Flute Length	Overall Length	Order Code SHR-025	Price/1 TB
1.00	33.0	56.0	-1630A	139.00	4.30	82.0	126.0	-1632G	133.00	8.50	109.0	165.0	-1635L	412.00
1.20	41.0	65.0	-1630E	139.00	4.40	82.0	126.0	-1632J	133.00	9.00	115.0	175.0	-1635Z	462.00
1.50	45.0	70.0	-1630J	114.00	4.50	82.0	126.0	-1632L	149.00	9.50	115.0	175.0	-1636E	464.00
2.00	56.0	85.0	-1630Q	105.00	5.00	87.0	132.0	-1632W	167.00	9.80	121.0	184.0	-1636L	567.00
2.10	56.0	85.0	-1630R	160.00	5.10	87.0	132.0	-1632X	167.00	10.00	121.0	184.0	-1636N	585.00
2.20	59.0	90.0	-1630S	160.00	5.20	87.0	132.0	-1632Y	167.00	10.20	121.0	184.0	-1636Q	558.00
2.30	59.0	90.0	-1630T	160.00	5.50	91.0	139.0	-1633F	191.00	10.50	121.0	184.0	-1636T	585.00
2.40	62.0	95.0	-1630W	105.00	5.80	91.0	139.0	-1633J	167.00	11.00	128.0	195.0	-1637A	691.00
2.50	62.0	95.0	-1630Y	105.00	6.00	91.0	139.0	-1633P	218.00	11.50	128.0	195.0	-1637F	797.00
2.80	66.0	100.0	-1631B	160.00	6.20	97.0	148.0	-1633R	2100.00	12.00	134.0	205.0	-1637P	891.00
3.00	66.0	100.0	-1631H	110.00	6.30	97.0	148.0	-1633S	239.00	12.50	134.0	205.0	-1637V	849.00
3.10	69.0	106.0	-1631K	170.00	6.40	97.0	148.0	-1633T	250.00	13.00	134.0	205.0	-1638Q	1046.00
3.20	69.0	106.0	-1631N	114.00	6.50	97.0	148.0	-1633X	247.00	13.50	140.0	214.0	-1638W	1906.00
3.30	69.0	106.0	-1631Q	115.00	6.80	120.0	156.0	-1634D	274.00	14.00	140.0	214.0	-1639R	1257.00
3.40	73.0	112.0	-1631T	170.00	7.00	120.0	156.0	-1634H	280.00	15.00	144.0	220.0	-1640S	1623.00
3.50	73.0	112.0	-1631V	120.00	7.20	102.0	156.0	-1634K	280.00	16.00	149.0	227.0	-1641T	1906.00
3.80	78.0	119.0	-1631Y	170.00	7.50	102.0	156.0	-1634N	292.00	17.00	154.0	235.0	-1642V	2189.00
4.00	78.0	119.0	-1632C	133.00	7.80	109.0	165.0	-1634R	319.00	18.00	158.0	241.0	-1643W	2498.00
4.10	78.0	119.0	-1632D	1200.00	8.00	109.0	165.0	-1635A	367.00	20.00	166.0	254.0	-1644X	3163.00
4.20	78.0	119.0	-1632F	139.00	8.20	109.0	165.0	-1635C	367.00					

SWISS+TECH HSS-Co Straight Shank Long Series Drills

Heavy-duty drill used for deep holes in steels with a tensile strength up to 1,400 N/mm². Stainless steels, heat and acid-resistant steels and hard bronze. Point angle: 135°. Helix angle: normal. Web thickness: strengthened. Relief angle: normal. Tolerance of diameter: h8. Tolerance of shank: f11. Manufacturing Standard: **DIN 340/BS328.**

HEAVY DUTY



HSS-Co



DIN 1412C 135°

Series 4000 - Metric

Diameter (mm)	Flute Length	Overall Length	Order Code SWT-125	Price/1 TB	Diameter (mm)	Flute Length	Overall Length	Order Code SWT-125	Price/1 TB	Diameter (mm)	Flute Length	Overall Length	Order Code SWT-125	Price/1 TB
3.00	66.0	100.0	-4030A	657.00	4.80	87.0	132.0	-4048A	1083.00	6.00	91.0	139.0	-4060A	1203.00
3.20	69.0	106.0	-4032A	657.00	5.00	87.0	132.0	-4050A	1022.00	6.50	97.0	148.0	-4065A	1323.00
3.50	73.0	112.0	-4035A	782.00	5.20	87.0	132.0	-4052A	1203.00	8.00	109.0	165.0	-4080A	1804.00
4.00	78.0	119.0	-4040A	782.00	5.50	91.0	139.0	-4055A	1143.00	8.50	109.0	165.0	-4085A	2044.00



HSS Extra Length Drills - Steam Tempered



HSS

General-purpose drills for steels, cast steel, grey cast iron, malleable cast iron, nickel brass, aluminium alloy and graphite.
 Point angle: 118°, helix angle: normal, web thickness: standard,
 relief angle: 10° - 20°, tolerance of diameter: h8, tolerance of shank: f11.
 Manufactured to **BS 328 : Part 1 : 1986**.

CUTTING TOOLS



Series E100 - Metric

Dia. (mm)	Flute Length	Overall Length	Order Code SHR-024	Price/1 TB	Dia. (mm)	Flute Length	Overall Length	Order Code SHR-024	Price/1 TB	Dia. (mm)	Flute Length	Overall Length	Order Code SHR-024	Price/1 TB
1.50	80.0	125.0	-2091B	531.00	4.50	250.0	315.0	-2114B	2266.00	8.00	300.0	400.0	-2138C	3446.00
1.50	100.0	160.0	-2092C	670.00	4.50	220.0	350.0	-2114F	2500.00	8.50	200.0	250.0	-2139D	1267.00
2.00	80.0	125.0	-2094E	376.00	5.00	100.0	160.0	-2115C	531.00	8.50	250.0	315.0	-2140E	2730.00
2.00	100.0	160.0	-2095F	459.00	5.00	150.0	200.0	-2116D	531.00	9.00	200.0	250.0	-2141F	1334.00
2.20	150.0	200.0	-2095H	773.00	5.00	200.0	250.0	-2117E	696.00	9.00	250.0	315.0	-2142G	2359.00
2.20	100.0	160.0	-2096G	567.00	5.00	250.0	315.0	-2118F	2503.00	9.00	300.0	400.0	-2143H	6448.00
2.50	80.0	125.0	-2097H	361.00	5.00	300.0	400.0	-2119G	2575.00	9.50	200.0	250.0	-2144J	1721.00
2.50	100.0	160.0	-2098J	567.00	5.50	150.0	200.0	-2120H	618.00	9.50	250.0	315.0	-2145K	3245.00
2.50	150.0	200.0	-2098L	876.00	5.50	200.0	250.0	-2121J	1262.00	10.00	200.0	250.0	-2146L	1504.00
3.00	100.0	160.0	-2099K	376.00	6.00	150.0	200.0	-2123L	639.00	10.00	250.0	315.0	-2147M	3101.00
3.00	150.0	200.0	-2100L	716.00	6.00	200.0	250.0	-2124M	799.00	10.00	300.0	400.0	-2148N	4167.00
3.00	200.0	250.0	-2101M	989.00	6.00	250.0	315.0	-2125N	1329.00	10.50	200.0	250.0	-2149P	2009.00
3.30	100.0	160.0	-2102N	747.00	6.00	300.0	400.0	-2126P	2987.00	10.50	250.0	315.0	-2150Q	3786.00
3.30	150.0	200.0	-2102Q	979.00	6.50	150.0	200.0	-2127Q	701.00	10.50	300.0	400.0	-2151R	4841.00
3.50	100.0	160.0	-2103P	402.00	6.50	200.0	250.0	-2128R	1381.00	11.00	200.0	250.0	-2152S	1741.00
3.50	150.0	200.0	-2104Q	541.00	6.50	250.0	315.0	-2129S	1906.00	11.00	250.0	315.0	-2153T	3621.00
3.50	200.0	250.0	-2105R	1010.00	7.00	150.0	200.0	-2130T	778.00	11.00	300.0	400.0	-2154V	5027.00
4.00	100.0	160.0	-2107T	376.00	7.00	200.0	250.0	-2131V	984.00	12.00	200.0	250.0	-2155W	2009.00
4.00	150.0	200.0	-2108V	464.00	7.00	250.0	315.0	-2132W	2730.00	12.00	250.0	315.0	-2156X	2534.00
4.00	200.0	250.0	-2109W	624.00	7.50	200.0	200.0	-2133X	969.00	12.00	300.0	400.0	-2157Y	5789.00
4.00	250.0	315.0	-2110X	1329.00	7.50	200.0	250.0	-2134Y	1108.00	13.00	250.0	315.0	-2158N	3245.00
4.50	100.0	160.0	-2111Y	603.00	7.50	250.0	315.0	-2135N	2292.00	13.00	300.0	400.0	-2159A	7030.00
4.50	150.0	200.0	-2112N	603.00	8.00	200.0	250.0	-2136A	1072.00	14.00	250.0	315.0	-2160B	6943.00
4.50	200.0	250.0	-2113A	1123.00	8.00	250.0	315.0	-2137B	1339.00	14.00	300.0	400.0	-2161C	8586.00

Series E100 - Inch

Dia. (inch)	Flute Length	Overall Length	Order Code SHR-024	Price/1 TB	Dia. (inch)	Flute Length	Overall Length	Order Code SHR-024	Price/1 TB	Dia. (inch)	Flute Length	Overall Length	Order Code SHR-024	Price/1 TB
1/16"	80.0	125.0	-1990A	531.00	1/4"	150.0	200.0	-2024M	649.00	7/16"	250.0	315.0	-2055W	2472.00
1/16"	100.0	160.0	-1991B	572.00	1/4"	200.0	250.0	-2025N	804.00	1/2"	200.0	250.0	-2059A	2318.00
3/32"	80.0	125.0	-1994E	350.00	1/4"	250.0	315.0	-2026P	1028.00	1/2"	250.0	315.0	-2060B	2921.00
3/32"	100.0	160.0	-1995F	392.00	1/4"	300.0	400.0	-2027Q	2138.00	1/2"	300.0	400.0	-2061C	3863.00
1/8"	100.0	160.0	-1998J	368.00	9/32"	150.0	200.0	-2032W	1329.00					
1/8"	150.0	200.0	-1999K	460.00	9/32"	200.0	250.0	-2033X	1360.00					
1/8"	200.0	250.0	-2000L	902.00	5/16"	150.0	200.0	-2035N	840.00					
1/8"	250.0	315.0	-2001M	2359.00	5/16"	200.0	250.0	-2036A	1051.00					
5/32"	150.0	200.0	-2005R	495.00	5/16"	250.0	315.0	-2037B	999.00					
5/32"	200.0	250.0	-2006S	804.00	11/32"	200.0	250.0	-2042D	2987.00					
3/16"	100.0	160.0	-2011Y	402.00	11/32"	200.0	250.0	-2042G	3039.00					
3/16"	150.0	200.0	-2012N	500.00	11/32"	300.0	400.0	-2044J	3605.00					
3/16"	200.0	250.0	-2013A	629.00	23/64"	250.0	315.0	-2046L	2369.00					
3/16"	250.0	315.0	-2014B	1788.00	3/8"	150.0	200.0	-2046Y	1180.00					
13/64"	150.0	200.0	-2016D	855.00	3/8"	200.0	250.0	-2047M	1339.00					
7/32"	150.0	200.0	-2019G	629.00	3/8"	250.0	315.0	-2048N	1700.00					
7/32"	200.0	250.0	-2020H	550.00	3/8"	300.0	400.0	-2049P	3472.00					
7/32"	250.0	315.0	-2021J	1133.00	13/32"	200.0	250.0	-2051R	1250.00					



HSS Extra Length Drill Set

Used for deep hole drilling in most materials. (Not suitable for the drilling of holes in crankshafts.)
 Manufactured to **BS 328 : Part 1 : 1986**.

HSS

METRIC

6
PIECES

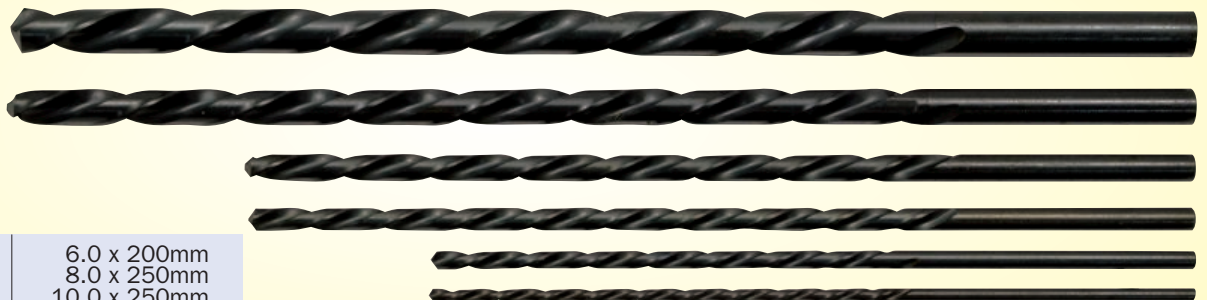

mm
3.0 ~ 10.0

3.0 x 160mm	6.0 x 200mm
4.0 x 160mm	8.0 x 250mm
5.0 x 200mm	10.0 x 250mm

Number of Pieces	Order Code SHR-025	Price/1 TB
6	-8600K	3605.00

PRODUCTS ARE ONLY AVAILABLE VIA YOUR DISTRIBUTOR



Bastard Cut

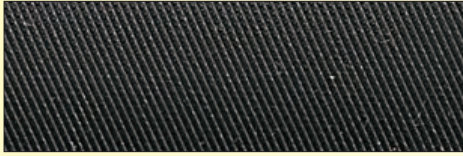

Second Cut

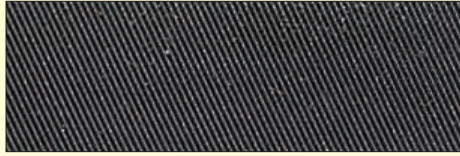

Smooth Cut



Double Cut - Two sets of diagonal rows of teeth, with the second set of teeth cut in opposite direction and on top of the first. The first set of teeth is known as 'overcut' and the second as 'upcut', upcut being the finer. Double cut files are used with heavier pressure than single cut and remove material faster from the workpiece.

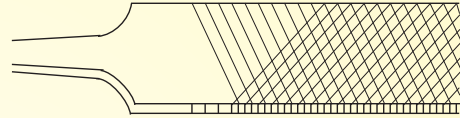

Hand - Parallel edges, one edge uncut. For flat filing, corner filing and deburring. Multi-purpose and for other work where a 'safe' or uncut edge is needed. Double cut.



Flat - Edges taper towards front. Applications as for hand files. Preferred where taper allows access into tight corners and angles. For general work on iron, steel, etc.



Round - Diameter tapers towards point. Suitable for internal and external concave surfaces.



Half-Round - Edges and surfaces taper towards point. Dual application; suitable for concave surfaces and flat filing. For rapid removal of metal.



Square - Parallel edges, surfaces taper towards point. For groove, rectangular hole and internal corner filing. Preferable to a Flat File because of its heavier section.



Three Square - Equilateral section (60° angles). Tapered towards point. For filing acute angles, internal corners and flat filing, clearing out square corners.



Knife - Two equal surfaces, tapered to knife point. For filing and deburring narrow grooves, slits and gear-teeth. Used principally by tool and die makers on work having acute angles.



Warding - Parallel surfaces, edges tapered to a point. For narrow grooves, keyways, slots etc. Warding Files are used by locksmiths in repairing or filing ward notches in keys. Also suited for use in narrow spaces. All sides double cut.



Pillar - Parallel edges, surfaces tapered towards end. Narrow version of hand file. For use where access is restricted. These files are designed for millwrights and mechanics for use in enlarging key-ways, slots, etc., close to the shoulder.



Single Cut - Single set of parallel diagonal rows of teeth, Often used with light pressure to produce a smooth surface finish or put a keen edge on knives, shears and saws.

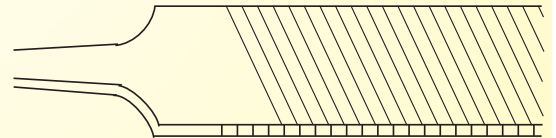

Double Ended Saw - Edges taper towards point. For filing and sharpening saws. Points are left uncut. Instead of having a tang, both ends are tapered. They are used for sharpening saws having a 60° angle. The teeth are cut from each end towards the centre.



Taper Saw - Edges taper towards point. For filing and sharpening hand saws. Points are left uncut. Taper Saw Files are used for filing every type of handsaw which have 60° angle teeth. These files are single cut with edges that are set and cut for filing the gullet between the saw teeth.

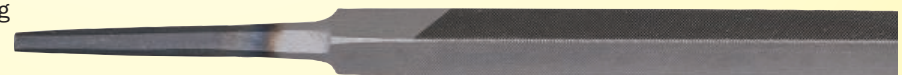

Mill Saw - Available with one or two round edges. Parallel edges, both edges cut for filing and sharpening saws.





KENNEDY PROFESSIONAL *Engineer's Files with Handles*

Fitted with ergonomically designed handles for a comfortable improved grip. Files manufactured from T12 CH-Moly alloy tool steel, hardened and tempered. Supplied in a woven wallet for easy storage.

Manufactured to BS498:1990 and American Federal Standard GGG-F325B.



Overall Length	Cut	Shape	Order Code KEN-030	Price/1 TB
150mm (6")	Second	Hand	-2070K	175.00
		Flat	-2170K	175.00
		Round	-2270K	185.00
		Half Round	-2370K	210.00
200mm (8")	Second	Hand	-4070K	195.00
		Flat	-4170K	195.00
		Round	-4270K	195.00
		Half Round	-4370K	225.00
250mm (10")	Second	Hand	-6070K	250.00
		Flat	-6170K	250.00
		Round	-6270K	250.00
		Half Round	-6370K	295.00

All files on this page feature the new **Kennedy Professional Grip** handles



Intelligent design for maximum control and reduced fatigue

Engineer's File Sets

4 Piece Sets

Set contains Hand, Flat, Round and Half Round second engineer's Sets available in 150mm (6"), 200mm (8") and 250mm (10").



NEW

**4
PIECES**

Overall Length	No. of Pieces	Cut	Order Code KEN-030	Price/1 TB
150mm (6")	4	Second	-9740K	1300.00
200mm (8")			-9760K	1500.00
250mm (10")			-9780K	1700.00

"Three-cut" Files with Handles

Unique Design - Three Files in One!

Triangular file, each face with a different cut; smooth cut (cut 1); second cut (cut 2) and bastard cut (Cut 3). Complete with bi-material handle designed for maximum comfort and added grip.

File length: 200mm (8").



NEW

Smooth Cut (Cut 1)



Second Cut (Cut 2)



Bastard Cut (Cut 3)



Overall Length	Cut	Shape	Order Code KEN-030	Price/1 TB
200mm (8")	Smooth Second Bastard	Triangular	-4540K	399.00

PRODUCTS ARE ONLY AVAILABLE VIA YOUR DISTRIBUTOR

KENNEDY *Engineer's Hand Files*
QUALITY INDUSTRIAL TOOLING

Available in a comprehensive range of shapes and sizes.
Manufactured to **BS 498 : 1990** and **American Federal Standard GGG-f-325b**.



KENNEDY PROFESSIONAL *Professional File Handles*

Polypropylene file handles with integral hanging hole and covered with a ribbed rubber grip for increased purchase and added comfort.

Available in three sizes: 0, 1 and 2.



Size	Suitable File Length (mm)	Order Code KEN-531	Price/1 TB
No. 0	100 - 150	-5000K	110.00
No. 1	200 - 250	-5010K	116.00
No. 2	300 - 400	-5020K	165.00

CUTTING TOOLS

Bastard Cut



Second Cut

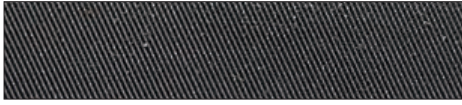

Smooth Cut



Overall Length	Type	Smooth Cut			Second Cut			Bastard Cut		
		Weight per 10	Order Code KEN-030	Price/1 TB	Weight per 10	Order Code KEN-030	Price/1 TB	Weight per 10	Order Code KEN-030	Price/1 TB
100mm (4")	Hand	0.27kg	-0010K	106.00	0.27kg	-0020K	106.00	0.27kg	-0030K	106.00
	Flat	0.27kg	-0110K	106.00	0.26kg	-0120K	106.00	0.26kg	-0130K	106.00
	Round	0.09kg	-0210K	113.00	0.09kg	-0220K	113.00	0.09kg	-0230K	113.00
	Half Round	0.29kg	-0310K	133.00	0.29kg	-0320K	133.00	0.29kg	-0330K	133.00
	Square	0.10kg	-0410K	139.00	0.10kg	-0420K	139.00	0.12kg	-0430K	139.00
	3 Square	0.27kg	-0510K	133.00	0.29kg	-0520K	133.00	0.31kg	-0530K	133.00
	Warding	0.11kg	-0710K	118.00	0.12kg	-0720K	118.00	0.12kg	-0730K	118.00
150mm (6")	Hand	0.73kg	-2010K	106.00	0.73kg	-2020K	106.00	0.77kg	-2030K	106.00
	Flat	0.74kg	-2110K	106.00	0.71kg	-2120K	106.00	0.71kg	-2130K	106.00
	Round	0.35kg	-2210K	113.00	0.34kg	-2220K	113.00	0.35kg	-2230K	113.00
	Half Round	0.72kg	-2310K	160.00	0.72kg	-2320K	160.00	0.72kg	-2330K	160.00
	Square	0.37kg	-2410K	123.00	0.40kg	-2420K	123.00	0.40kg	-2430K	123.00
	3 Square	0.86kg	-2510K	128.00	0.82kg	-2520K	128.00	0.82kg	-2530K	128.00
	Knife	0.59kg	-2610K	182.00	0.62kg	-2620K	182.00	0.62kg	-2630K	182.00
	Warding	0.35kg	-2710K	160.00	0.36kg	-2720K	160.00	0.36kg	-2730K	160.00
Pillar	0.35kg	-2810K	123.00	0.35kg	-2820K	123.00	0.36kg	-2830K	123.00	
175mm (7")	Double Ended	-	-	-	0.33kg	-2930K	139.00	-	-	-
	Taper Saw	-	-	-	0.88kg	-2940K	150.00	-	-	-
200mm (8")	Double Ended	-	-	-	0.34kg	-3930K	170.00	-	-	-
	Hand	1.70kg	-4010K	137.00	1.75kg	-4020K	137.00	1.60kg	-4030K	137.00
	Flat	1.35kg	-4110K	137.00	1.35kg	-4120K	137.00	1.35kg	-4130K	137.00
	Round	0.60kg	-4210K	133.00	0.60kg	-4220K	133.00	0.60kg	-4230K	133.00
	Half Round	1.50kg	-4310K	199.00	1.50kg	-4320K	199.00	1.55kg	-4330K	199.00
	Square	0.81kg	-4410K	133.00	0.85kg	-4420K	133.00	0.83kg	-4430K	133.00
	3 Square	2.00kg	-4510K	161.00	1.80kg	-4520K	161.00	1.90kg	-4530K	161.00
	Knife	1.35kg	-4610K	256.00	1.40kg	-4620K	256.00	1.30kg	-4630K	256.00
	Warding	1.00kg	-4710K	187.00	0.90kg	-4720K	187.00	0.76kg	-4730K	187.00
	Pillar	0.67kg	-4810K	170.00	0.85kg	-4820K	170.00	0.70kg	-4830K	170.00
	Millsaw	-	-	-	1.90kg	-4920K	133.00	-	-	-
Double Ended	-	-	-	0.50kg	-4930K	123.00	-	-	-	
Taper Saw	-	-	-	0.72kg	-4940K	140.00	-	-	-	
225mm (9")	Double Ended	-	-	-	0.75kg	-5930K	140.00	-	-	-
255mm (10")	Hand	3.00kg	-6010K	219.00	3.10kg	-6020K	219.00	3.10kg	-6030K	219.00
	Flat	2.90kg	-6110K	223.00	2.90kg	-6120K	223.00	2.70kg	-6130K	223.00
	Round	1.30kg	-6210K	157.00	1.30kg	-6220K	157.00	1.25kg	-6230K	157.00
	Half Round	2.55kg	-6310K	308.00	2.55kg	-6320K	308.00	2.60kg	-6330K	308.00
	Square	1.60kg	-6410K	169.00	1.70kg	-6420K	169.00	1.75kg	-6430K	169.00
	3 Square	1.85kg	-6510K	208.00	2.70kg	-6520K	208.00	3.00kg	-6530K	208.00
	Warding	-	-	-	1.60kg	-6720K	212.00	1.50kg	-6730K	212.00
Millsaw	-	-	-	2.10kg	-6910K	294.00	-	-	-	
Double Ended	-	-	-	0.97kg	-6930K	160.00	-	-	-	
305mm (12")	Hand	4.30kg	-7010K	308.00	4.35kg	-7020K	308.00	4.40kg	-7030K	308.00
	Flat	4.20kg	-7110K	308.00	4.30kg	-7120K	308.00	4.50kg	-7130K	308.00
	Round	2.50kg	-7210K	266.00	2.40kg	-7220K	266.00	2.45kg	-7230K	266.00
	Half Round	4.60kg	-7310K	436.00	4.35kg	-7320K	436.00	4.40kg	-7330K	436.00
	Square	3.20kg	-7410K	318.00	3.25kg	-7420K	318.00	1.40kg/5	-7430K	318.00
	3 Square	4.50kg	-7510K	335.00	4.95kg	-7520K	335.00	4.55kg	-7530K	335.00
1 Round Edge Mill	-	-	-	1.20kg/5	-7910K	266.00	-	-	-	
355mm (14")	Hand	3.70kg/5	-8010K	403.00	3.70kg/5	-8020K	403.00	3.40kg/5	-8030K	403.00
	Flat	2.23kg/5	-8110K	384.00	3.45kg/5	-8120K	384.00	3.30kg/5	-8130K	384.00
	Round	2.45kg/5	-8210K	484.00	2.50kg/5	-8220K	484.00	2.55kg/5	-8230K	484.00
	Half Round	2.90kg/5	-8310K	488.00	3.50kg/5	-8320K	488.00	3.55kg/5	-8330K	488.00
	Square	3.10kg/5	-8410K	388.00	3.00kg/5	-8420K	388.00	3.07kg/5	-8430K	388.00
3 Square	-	-	-	3.35kg/5	-8520K	409.00	3.50kg/5	-8530K	409.00	
405mm (16")	Hand	-	-	-	-	-	5.30kg/5	-9030K	452.00	
	Flat	-	-	-	5.10kg/5	-9120K	452.00	5.00kg/5	-9130K	452.00
	Half Round	-	-	-	4.85kg/5	-9320K	600.00	4.75kg/5	-9330K	600.00
	Square	-	-	-	-	-	4.45kg/5	-9430K	797.00	

SENATOR *Engineer's File Sets*



A selection of popular engineer's files suitable for filing and deburring on a wide variety of materials. Double cut teeth for rapid metal removal. Ideal for workshop or garage. Manufactured to **BS498:1990** and American Federal Standard **GGG-F-3256**.

Contents (1 of each): bastard cut hand, second cut flat, round and half round.

**4
PIECES**

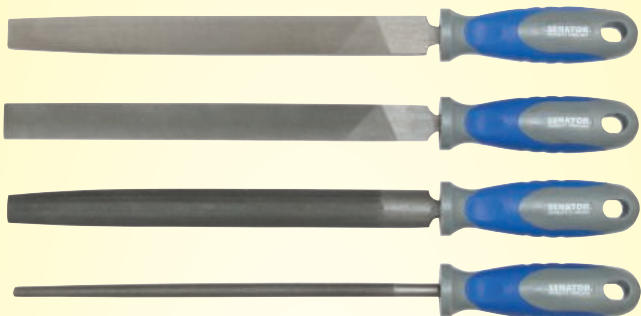

Number of Pieces	Size	Order Code SEN-030	Price/1 TB
4	150mm (6")	-9510K	484.00
4	200mm (8")	-9520K	590.00
4	255mm (10")	-9530K	696.00

Engineer's Second Cut File Set

A selection of popular engineer's files suitable for filing and deburring on a wide variety of materials. Ideal for workshop or garage. Double cut teeth for rapid metal removal.

Contents (1 of each) Second Cut:

Hand: 305mm (12"), 255mm (10"), 200mm (8"), 125mm (5").

Flat: 305mm (12"), 255mm (10"), 200mm (8"), 125mm (5").

Round: 305mm (12"), 255mm (10"), 200mm (8").

Half round: 305mm (12"), 255mm (10"), 200mm (8").

**14
PIECES**



Number of Pieces	Order Code SEN-030	Price/1 TB
14	-9800K	1327.00

Engineer's File Set

A selection of popular engineer's files suitable for filing and deburring on a wide variety of materials. Ideal for workshop or garage. Double cut teeth for rapid metal removal.

Contents: (1 of each)

150mm (6"):

Hand: smooth, second. **Flat:** smooth, second, bastard.

Half round: second. **Round:** bastard.

200mm (8"):

Hand: second. **Flat:** second. **Half Round:** second. **Round:** second.

255mm (10"):

Hand: second, bastard.

Flat: smooth, second, bastard.

Half round: second.

Round: bastard.

305mm (12"):

Flat: second, bastard.

**20
PIECES**

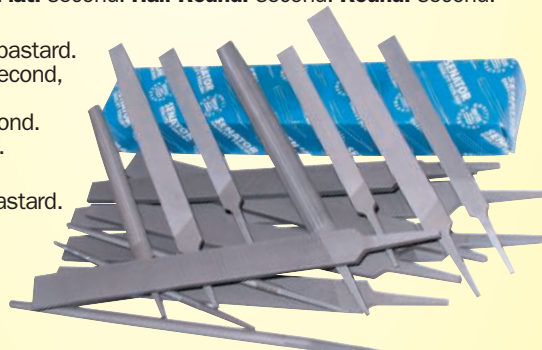

Number of Pieces	Order Code SEN-030	Price/1 TB
20	-9840K	1725.00

KENNEDY *Engineer's Second Cut File Sets*



Contents (1 of each):

flat, hand, round, half-round three-square and square. Plus two file handles, supplied in PVC wallet. Manufactured to **BS498 : 1990** & **US Federal Standards**.



**8
PIECES**

Number of Pieces	Set Size	Handle Size	Weight each	Order Code KEN-030	Price/1 TB
8	150mm (6")	75mm (3")	0.44kg	-9860K	770.00
8	200mm (8")	100mm (4")	0.89kg	-9880K	972.00
8	255mm (10")	125mm (5")	1.65kg	-9900K	1470.00

Engineer's Double Cut File Set

Bastard cut one side and 2nd cut on other.

Contents (1 of each):

three square, half round and round bastard cut files, flat, hand and square 'double cut'. 200mm (8"). Supplied with two file handles in plastic wallet.



**8
PIECES**

Number of Pieces	Order Code KEN-030	Price/1 TB
8	-9930K	1380.00

Second Cut File Set

Contents:

(1 of each) 150mm (6") and 255mm (10") files;

(3 of each) flat;

(2 of each) half-round;

(1 of each) round;

1 of 6 piece 16cm cut 2, needle file set.

**18
PIECES**



Number of Pieces	Order Code KEN-030	Price/1 TB
18	-9990K	2494.00



**Precision Hand Files
Needle Pattern (Round Handle)**



Available in 14cm and 16cm lengths and a complete range of shapes. Manufactured to **BS 498:1990**.

CUTTING TOOLS

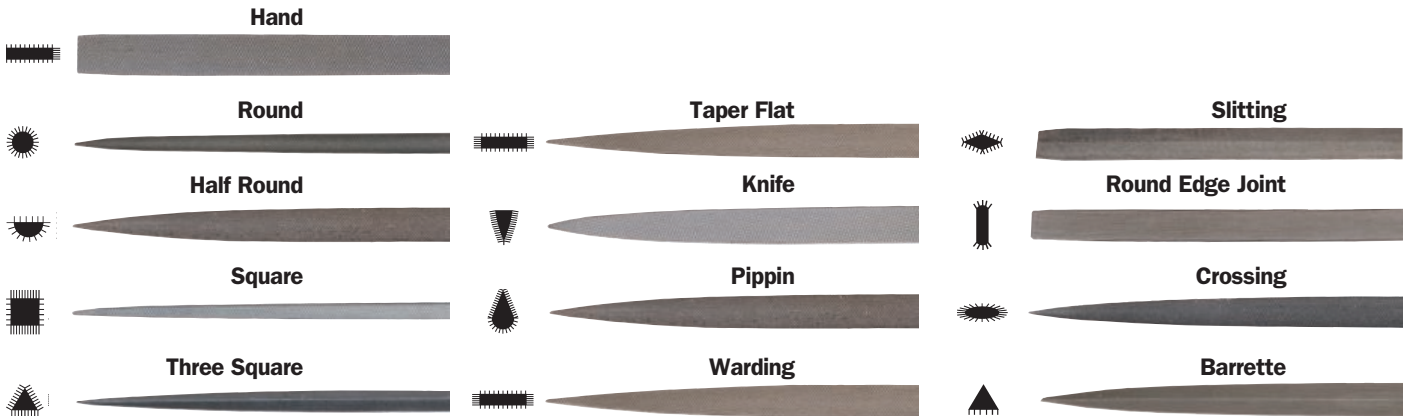

Overall Length	Type	Weight per 10	Cut 0		Cut 2		Cut 4	
			Order Code KEN-031	Price/1 TB	Order Code KEN-031	Price/1 TB	Order Code KEN-031	Price/1 TB
140mm (5½")	Hand	80g	-5000K	113.00	-5020K	113.00	-5040K	113.00
	Round	75g	-5200K	113.00	-5220K	113.00	-5240K	113.00
	Half Round	75g	-5300K	113.00	-5320K	113.00	-5340K	113.00
	Square	80g	-5400K	113.00	-5420K	113.00	-5440K	113.00
	3 Square	70g	-5500K	113.00	-5520K	113.00	-5540K	113.00
	Taper Flat	70g	-	-	-5560K	113.00	-5570K	113.00
	Knife	70g	-5600K	113.00	-5620K	113.00	-5640K	113.00
	Warding	70g	-5700K	113.00	-5720K	113.00	-5740K	113.00
	Slitting	80g	-	-	-5820K	113.00	-	-
	Crossing	75g	-	-	-5920K	113.00	-	-
	Barrette	80g	-	-	-5960K	113.00	-	-
	160mm (6½")	Hand	80g	-6000K	81.00	-6020K	81.00	-6040K
Round		75g	-6200K	81.00	-6220K	81.00	-6240K	81.00
Half Round		75g	-6300K	81.00	-6320K	81.00	-6340K	81.00
Square		80g	-6400K	81.00	-6420K	81.00	-	-
3 Square		70g	-6500K	81.00	-6520K	81.00	-6540K	81.00
Taper Flat		70g	-	-	-6560K	118.00	-	-
Knife		70g	-6600K	118.00	-6620K	118.00	-	-
Warding		70g	-6700K	118.00	-6720K	118.00	-	-
Slitting		80g	-	-	-6820K	118.00	-	-
Crossing		75g	-	-	-6920K	118.00	-	-
Barrette		80g	-	-	-6960K	118.00	-	-

Needle File Sets

Supplied in PVC wallet.
Manufactured to **BS 498:1990**. Cut 2.

6 Piece Set (1 of each):

flat, hand, half round, round, square, three square



12 Piece Set (1 of each):

hand, flat, knife, round, half round, square, three square, crossing, round edge joint, slitting, warding, barrette.



Number of Pieces	Weight each	Order Code KEN-031	Price/1 TB
14cm			
6	50g	-5980K	436.00
12	120g	-5990K	723.00
16cm			
6	70g	-6980K	680.00
12	150g	-6990K	1166.00

SENATOR Needle File Sets

Supplied in PVC wallet.
Manufactured to **BS 498:1990**. Cut 2.

6 Piece Set (1 of each):

warding, hand, half round, round, square, three square.



12 Piece Set (1 of each):

hand, flat, knife, round, half round, square, three square, crossing, round edge joint, slitting, warding, barrette.



Number of Pieces	Weight each	Order Code SEN-031	Price/1 TB
16cm			
6	50g	-6980K	515.00
12	120g	-6990K	987.00

KENNEDY Diemakers
QUALITY INDUSTRIAL TOOLING® **Riffler Files**

Swiss Pattern

Available in a complete range of shapes, the 15cm are used by diemakers, jewellers, silversmiths, engravers etc. All are double ended with the same cut both ends.



Riffler File Set

Set A 15cm - Cut 2

Contents (1 of each):

900, 911, 914, 916, 918, 940, 952, 957, 981, 983, 985 and 987.



**12
PIECES**



Number of Pieces	Weight Set	Order Code	Price/1 TB
12	310g	KDY-031 -9110K	7983.00

Set B 15cm - Cut 2

Contents (1 of each):

905, 913, 915, 917, 931, 943, 955, 963, 982, 984, 986 and 996.



**12
PIECES**



Number of Pieces	Weight Set	Order Code	Price/1 TB
12	310g	KDY-031 -9120K	7983.00

15cm Riffler Files - Cut 2

Illustration	Style Number	Weight per 10	Order Code	Price/1 TB
	900	120g	-7020K	926.00
	905	110g	-7100K	926.00
	911	120g	-7180K	926.00
	913	120g	-7260K	926.00
	914	120g	-7300K	926.00
	915	120g	-7340K	926.00
	916	110g	-7380K	926.00
	917	120g	-7420K	926.00
	918	110g	-7460K	926.00
	931	120g	-7620K	926.00
	940	90g	-7660K	926.00
	943	120g	-7780K	926.00
	952	110g	-7900K	926.00
	955	120g	-7980K	926.00
	957	120g	-8060K	926.00
	963	120g	-8220K	926.00
	981	120g	-8620K	926.00
	982	100g	-8660K	926.00
	983	100g	-8700K	926.00
	984	100g	-8740K	926.00
	985	140g	-8780K	926.00
	986	120g	-8820K	926.00
	987	130g	-8860K	926.00
	996	120g	-9060K	926.00

PRODUCTS ARE ONLY AVAILABLE VIA YOUR DISTRIBUTOR

GROUP 032 MILLED TOOTH FILES & RASPS

KENNEDY Milled Tooth Hand Files
QUALITY INDUSTRIAL TOOLING

Manufactured from alloy steel and feature undercut teeth that produce a more aggressive cut than conventional files and requires less operator effort. Suitable for use on a wide variety of materials including aluminium, steels, alloys, brass, copper, wood, plastics etc. Available as standard cut in four blade lengths and two tooth forms. Other styles are available on request.

Please note: handles are not supplied as standard and should be ordered separately as required.

Straight Tooth



Overall Length	Weight per 10	Order Code KEN-032	Price/1 TB
200mm (8")	1.30kg	-2080K	489.00
255mm (10")	2.10kg	-2100K	654.00
305mm (12")	2.90kg	-2120K	898.00
355mm (14")	5.30kg	-2140K	982.00



Rasp Cut Files

Series of individual teeth which are formed by a single pointed tool. Produces a rough cut that is used primarily on wood, hooves, aluminium and lead.

Rasps

Designed for general use and best suited to softer materials such as wood, plastics, fillers, leather and lead.

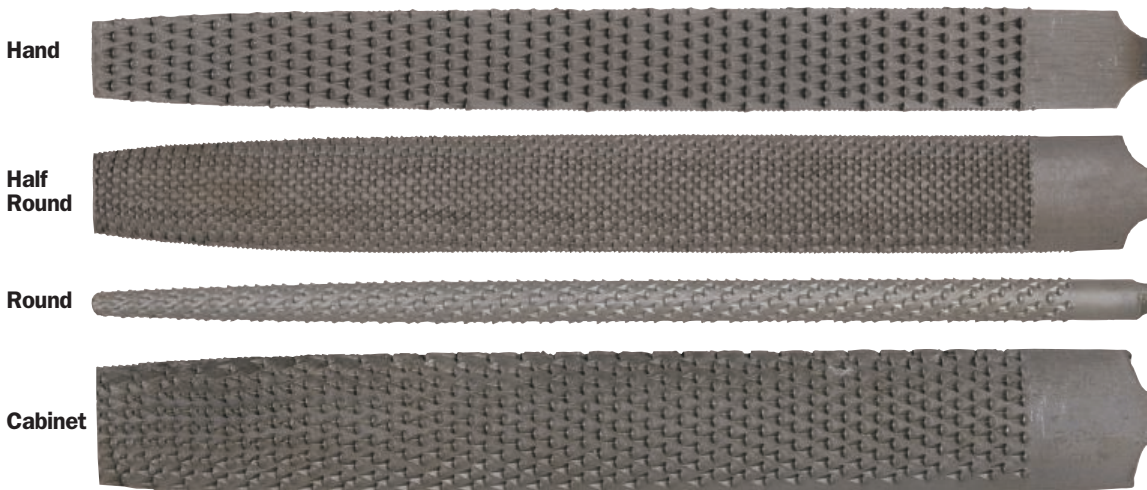

Overall Length	Type	Weight per 10	Smooth		Second		Bastard	
			Order Code KEN-032	Price/1 TB	Order Code KEN-032	Price/1 TB	Order Code KEN-032	Price/1 TB
150mm (6")	Hand	0.80kg	-	-	-3020K	318.00	-3030K	318.00
	Half Round	0.80kg	-3110K	441.00	-3120K	441.00	-3130K	441.00
	Round	0.80kg	-	-	-3220K	473.00	-3230K	473.00
200mm (8")	Hand	1.70kg	-3610K	314.00	-3620K	314.00	-3630K	314.00
	Half Round	1.50kg	-3710K	558.00	-3720K	558.00	-3730K	558.00
	Round	0.90kg	-	-	-	-	-3830K	574.00
255mm (10")	Cabinet	2.10kg	-	-	-	-	-3930K	574.00
	Hand	2.75kg	-4210K	574.00	-4220K	574.00	-4230K	574.00
	Half Round	2.65kg	-4310K	574.00	-4320K	574.00	-4330K	574.00
	Round	1.70kg	-4410K	680.00	-4420K	680.00	-4430K	680.00
305mm (12")	Cabinet	3.00kg	-	-	-4520K	606.00	-4530K	606.00
	Hand	4.60kg	-4810K	685.00	-4820K	685.00	-4830K	685.00
	Half Round	4.60kg	-	-	-4920K	712.00	-4930K	712.00
	Round	2.50kg	-	-	-5020K	802.00	-5030K	802.00
355mm (14")	Cabinet	4.00kg	-	-	-	-	-5130K	654.00
	Hand	5.30kg	-	-	-	-	-	-

Curved Tooth Files

Curved Cut

Teeth are arranged in curved contours across the file face. Normally used in automotive body shops for smoothing body panels.

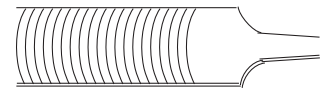

Overall Length	Weight per 10	Order Code KEN-032	Price/1 TB
200mm (8")	1.30kg	-1080K	489.00
255mm (10")	2.00kg	-1100K	654.00
305mm (12")	4.00kg	-1120K	892.00
355mm (14")	5.90kg	-1140K	982.00

Curved Tooth File Set

Contents: (1 of each) Flat, 200mm (8"), 255mm (10") and 305mm (12") standard cut.

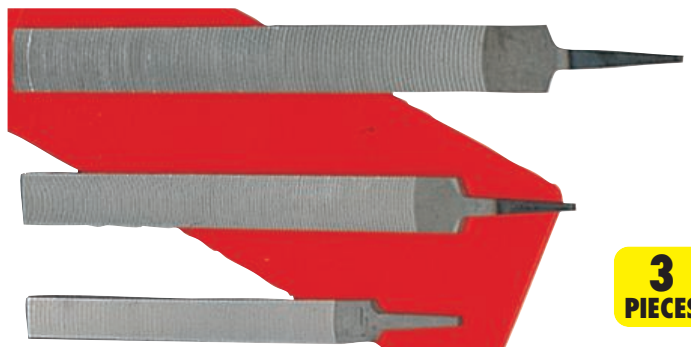

3 PIECES

Number of Pieces	Weight each	Order Code KEN-032	Price/1 TB
3	765g	-1830K	1380.00

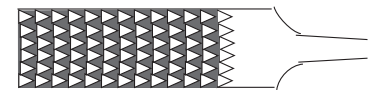

SENATOR QUALITY TOOLING **Diamond Needle & Riffler Files**

14cm
Diamond files, with soft touch foam rubber handles for comfort.

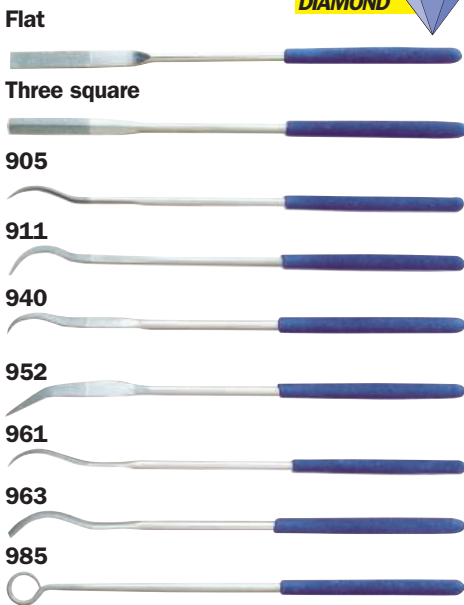

Style	Order Code SEN-033	Price/1 TB
Flat	-1510K	266.00
3 Square	-1560K	266.00
905	-2010K	266.00
911	-2020K	266.00
940	-2030K	266.00
952	-2040K	266.00
961	-2050K	266.00
963	-2060K	266.00
985	-2070K	266.00

Diamond Riffler & Needle File Set

14cm
Contains the most commonly used shapes, supplied in a vinyl wallet.

Contents:
1x of each needle file: flat, three square and slitting.

1x of each style riffler: 985, 911, 905, 940, 952, 961 and 963.



Number of Pieces	Order Code SEN-033	Price/1 TB
10	-2700K	2388.00

DIAMOND FILES

Diamond Needle File Set



6 PIECES

16cm
150 grain (medium grade). With tapered handles. Supplied in PVC wallet. Suitable for light duty and workshop use.

Contents: hand, half round, three square, round, square and knife.



Number of Pieces	Weight each	Order Code SEN-033	Price/1 TB
6	115g	-0600K	1697.00

KENNEDY QUALITY INDUSTRIAL TOOLING **Industrial Diamond Coated Needle Files**



16cm
Available in seven shapes and two grain sizes offering the solution to finishing problems where material hardness makes conventional files ineffective. Plated with finely selected diamond powder, 120 - 150 mesh. Can be used on tungsten carbide, ceramics, carbon, glass, fibreglass and hardened steels such as stainless steel, nimonics, titanium etc.



Type	Weight per 6	120/140 Grain		325/400 Grain	
		Order Code KEN-033	Price/1 TB	Order Code KEN-033	Price/1 TB
Hand	70g	-0020K	372.00	-0220K	351.00
H/Round	60g	-0040K	351.00	-0240K	351.00
3 Square	60g	-0060K	351.00	-0260K	351.00
Round	60g	-0080K	351.00	-0280K	351.00
Square	60g	-0100K	351.00	-0300K	351.00
Knife	60g	-0120K	351.00	-0320K	351.00
Flat	60g	-0140K	351.00	-0340K	351.00

Diamond Needle File Set



6 PIECES

16cm
120/140 grain.
Contents: hand, half round, three square, round, square and knife.

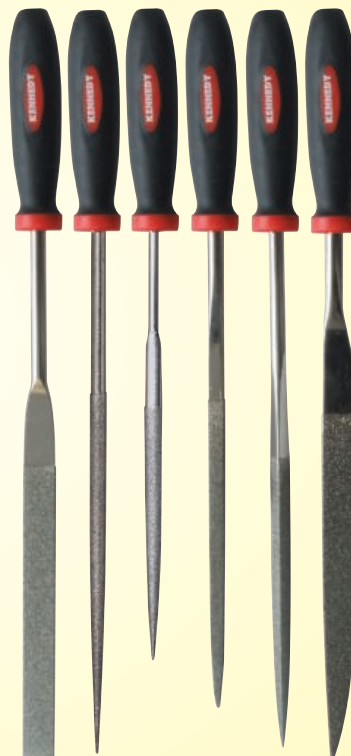

Number of Pieces	Weight each	Order Code KEN-033	Price/1 TB
6	60g	-0500K	2080.00

PRODUCTS ARE ONLY AVAILABLE VIA YOUR DISTRIBUTOR

GROUP 040 HACKSAW & POWERSAW BLADES

KENNEDY Flexible Back Bi-metal Hacksaw Blades
QUALITY INDUSTRIAL TOOLING

The perfect combination of shatter resistant spring steel, used as the backing material, and tough, wear-resistant HSS teeth - Electron-beam welded together. Ideal for interrupted cuts in cramped places or where the blade is subject to stress caused by twisting or bending. Provides optimum tooth strength/life and reduced breakage and fracture when compared to traditional all-hard blades. Made to BS 1919 : Part 1: 1993.



CUTTING TOOLS

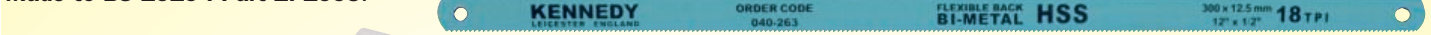

Improved re-usable packaging

Length	Width	Thickness	TPI	Weight per 100	Order Code KEN-040	Price/1 TB
10"	1/2"	.025	18T	1.50kg	-2130K	32.00
10"	1/2"	.025	24T	1.40kg	-2250K	32.00
10"	1/2"	.025	32T	1.40kg	-2320K	32.00
12"	1/2"	.025	14T	1.70kg	-2510K	32.00
12"	1/2"	.025	18T	1.70kg	-2630K	33.00
12"	1/2"	.025	24T	1.70kg	-2750K	33.00
12"	1/2"	.025	32T	1.70kg	-2870K	33.00

TPI Selection Guide

Group	Materials	Brinell Hardness HB	Rockwell Hardness HRC	Tensile Strength N/mm ²	Number of Teeth per Inch Section thickness or diameter		
					Below 2mm	2 - 5 mm	Above 5mm
1.1	Mild steel	<200	-	<700	32	24	18
1.4 to 1.5	Alloy steel & tool steel low to medium	<260	<26	<850	32	24	18 - 24
1.6	High alloy steel	>340	>36	>1200	32	24	24
2.1	Stainless steels	<290	<30	<1000	32	24	28
3.1	Grey cast iron	<300	-	-	24 - 32	18 - 24	18
6.1	Asbestos and copper	-	-	<500	24 - 32	18 - 24	18
6.3	Brass and bronze	-	-	<500	24 - 32	18 - 24	18
7.1	Aluminium	-	-	<500	24 - 32	18 - 24	18
8.1	Hard plastic	-	-	-	24 - 32	18 - 24	18

HSS All Hard Hacksaw Blades

Fully hardened for extra long tooth life and maximum straightness of cut. For use where workpiece is held securely in place. Made to BS 1919 : Part 1: 1993.



Improved re-usable packaging

Length	Width	Thickness	TPI	Weight per 100	Order Code KEN-040	Price/1 TB
10"	1/2"	.025	18T	1.40kg	-3130K	33.00
10"	1/2"	.025	24T	1.40kg	-3250K	33.00
12"	1/2"	.025	14T	1.70kg	-3510K	33.00
12"	1/2"	.025	18T	1.70kg	-3630K	33.00
12"	1/2"	.025	24T	1.70kg	-3750K	33.00
12"	1/2"	.025	32T	1.70kg	-3870K	33.00



Coping Saw Blades

For cutting and shaping in wood. Supplied in packs of 10.

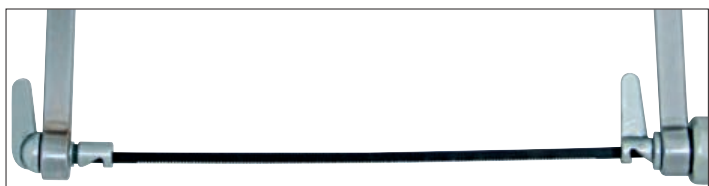

Length	TPI	Weight per 100	Order Code KEN-040	Price/10 TB
150mm (6")	14	250g	-1020K	140.00

Tile Saw Blades

For cutting and shaping ceramic tiles. Supplied in packs of 10.



Length	Grit Size	Pack Qty	Order Code KEN-040	Price/1 TB
150mm (6")	Medium	1	-1400K	155.00

SENATOR Flexible High Carbon Hacksaw Blades
QUALITY TOOLING

For general cutting/sawing. Available in a choice of 18 and 24TPI. Made to BS 1919 : Part 1: 1993. Packs of 10.



NEW

PACK OF 10



Length	Width	Thickness	TPI	Weight per pack	Order Code SEN-040	Price/pk TB
12"	1/2"	.025	18T	200g	-2630K	125.00
12"	1/2"	.025	24T	200g	-2750K	125.00

Junior Hand Saw Blades

Designed for use across a wide range of ferrous and non-ferrous materials. Suitable for mini hand saws and junior hacksaws. Made to BS 6271 : 1990.

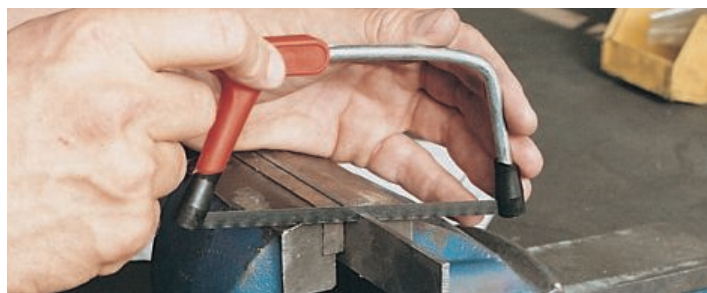

Type	Length	TPI	Weight per 100	Order Code KEN-040	Price TB
Metal Pack 10	150mm (6")	32	420g	-0620K	67.00/10
Wood	150mm (6")	14	390g	-0640K	21.00/1

KENNEDY Industrial Power / Machine Saw Blades
QUALITY INDUSTRIAL TOOLING

Designed for use across a wide range of ferrous and non-ferrous materials.

Power Saw Blade Selection

Power Saw Hacksaw Blade Tooth Recommendations

TPI	Suitable for Section Width
18	up to 13mm (up to 1/2")
14	6 to 19mm (1/4" to 3/4")
10	8 to 25mm (5/16" to 1)
6	13 to 38mm (1/2" to 1 1/2")
4	19mm and above (3/4" and above)

Type of Machine	Coolant Required	Unannealed Tool Steel & Hard Metals	Annealed Tool Steel	Machinery Steel & Soft Metal
Light	No	40spm	50 - 60spm	50-60spm
Medium	No	40spm	50 - 60spm	50-60spm
Medium	Yes	60spm	60 - 90spm	100-110spm
Heavy	Yes	60spm	90spm	110-120spm
Ex. Heavy	Yes	60spm	90spm	110-120spm

18 Teeth Per Inch

Recommended for cutting thin cross-sections such as tubing, small bars and light angle iron. Because blades are relatively thin they should be used only on light machines.

10 - 14 Teeth Per Inch

Recommended for cutting small cross sections and hard stock. This is the most popular choice for machine shops that are cutting a wide variety of materials.

4 - 6 Teeth Per Inch

Recommended for cutting large sections of softer ferrous metals, most alloy steels and all non-ferrous metals. The increased gullet clearance is able to handle heavy chips without clogging.

Operating Recommendations

Lower speeds and higher feed give best results. Ensure that the machine lifts the blade slightly on the return stroke. Exact speed and feed for each job can be established only from tests. The table below is to be used for guidance only.

When matching a section thickness against a suitable Blade TPI there are usually a number of blade options - Use coarse pitches (less TPI) for faster cutting and finer pitches (more TPI) for better surface finishes.

HSS All Hard Power Saw Blades

Recommended for cutting thin cross-sections such as tubing, small bars and light angle iron. Because blades are relatively thin they should be used only on light machines.



Length	Width	Thickness	TPI	Weight per 10	Order Code KEN-040	Price/1 TB
12"	5/8"	.032"	18T	0.36kg	-4630K	199.00
12"	1"	.050"	10T	0.78kg	-5030K	248.00
12"	1"	.050"	14T	0.79kg	-5040K	248.00
14"	1"	.050"	10T	0.93kg	-5130K	258.00
14"	1"	.050"	14T	0.80kg	-5140K	258.00
14"	1 1/4"	.062"	6T	1.30kg	-5200K	361.00
14"	1 1/4"	.062"	10T	1.30kg	-5220K	361.00
14"	1 1/4"	.062"	14T	1.30kg	-5230K	361.00
16"	1 1/4"	.062"	6T	1.40kg	-5390K	392.00
16"	1 1/4"	.062"	10T	0.90kg	-5410K	392.00
16"	1 1/4"	.062"	14T	1.60kg	-5420K	392.00
16"	1 1/2"	.062"	4T	2.20kg	-5490K	495.00
16"	1 1/2"	.062"	6T	2.20kg	-5500K	495.00
17"	1 1/4"	.062"	10T	1.80kg	-5530K	567.00
18"	1 1/4"	.062"	6T	1.90kg	-5550K	577.00
18"	1 1/4"	.062"	10T	1.60kg	-5570K	577.00
18"	1 1/2"	.075"	6T	2.55kg	-5650K	567.00
19"	1 3/4"	.088"	6T	3.80kg	-5720K	979.00
20"	1 1/2"	.075"	6T	3.20kg	-5750K	1133.00
21"	1 1/2"	.075"	6T	3.00kg	-5770K	1236.00
21"	1 1/2"	.075"	10T	3.00kg	-5790K	1339.00
21"	1 3/4"	.088"	6T	5.30kg	-5820K	1391.00
24"	2"	.100"	6T	6.30kg	-5960K	1545.00

Speeds & Feeds - Recommended speeds, strokes per minute and TPI.

Group	Materials	Brinell Hardness HB	Rockwell Hardness HRC	Tensile Strength N/mm ²	Cutting Speed m/min	Strokes Per Min	Section Thickness or diameter-Recommended TPI			
							Below 10mm	10-40 mm	40-80 mm	Above 80mm
1.1 to 1.2	General purpose steels mild and structural	<200	-	<700	25 - 35	70 - 90	14	10 - 6	6 - 4	4
1.3	Non-alloy, plain and medium carbon steels and castings	<260	<26	<850	20 - 30	50 - 70	14	10 - 6	6 - 4	4 - 3
1.4	Alloy steels generally low to medium steels and castings	<260	<26	<850	20 - 30	50 - 70	14	10 - 6	6 - 4	4 - 3
1.5	Medium to high alloy steels tool steels and steel castings	>260 <340	>26 <36	>850 <1200	18 - 28	40 - 60	14	10 - 6	6 - 4	4 - 3
1.6	Heat treated high alloy steels and castings	>340 <450	>36 <48	>1200 <1500	15 - 25	30 - 45	14	10 - 6	6 - 4	4 - 3
2.1 to 2.3	Stainless steels free machine and austenitic	<290	<30	<1000	10 - 25	40 - 60	14	10 - 6	6 - 4	4 - 3
3.1 to 3.2	Grey cast iron	<300	-	-	30 - 40	70 - 90	14	10 - 6	6 - 4	4 - 3
3.3 to 3.4	S.G. iron nodular and malleable	<300	-	-	30 - 40	70 - 90	14	10 - 6	6 - 4	4 - 3
6.1 to 6.3	Non ferrous metals brass, copper and bronze	-	-	<800	40 - 60	80 - 115	14	10 - 6	6 - 4	4 - 3
7.1 to 7.4	Aluminium alloys to zinc and magnesium	-	-	<50	40 - 60	80 - 115	14 - 10	10 - 6	6 - 4	4 - 3



KENNEDY *Holesaw Arbors*
QUALITY INDUSTRIAL TOOLING

Precision machined and threaded, guaranteeing a smooth secure fit to all popular brands of holesaws. Made from alloy steel. Suitable for use with all power tools.

For Saw Sizes upto 32mm



K1-SDS
Pilot supplied separately.



Product Number	For Saw Size	Order Code KEN-050	Price/1 TB
K4	14 - 30mm	-1750K	274.00
K1	14 - 30mm	-1600K	372.00
K1-SDS	14 - 32mm	-1550K	428.00

For Saw Sizes upto 152mm

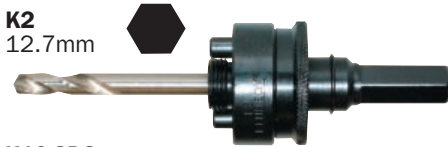
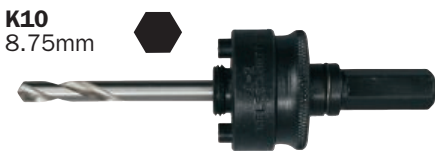

K10-SDS
Pilot supplied separately.



Product Number	For Saw Size	Order Code KEN-050	Price/1 TB
K10	32 - 152mm	-1850K	651.00
K2	32 - 152mm	-1650K	657.00
K10-SDS	33 - 152mm	-1560K	794.00

Pilot Drills

HSS, ground flute. Not suitable for stainless steel.



Product Number	To Suit Arbors	Weight each	Order Code KEN-050	Price/1 TB
K14C	All except K4	20g	-1930K	83.00
K14D	K4 only	30g	-1960K	83.00

Ejector Spring

Manufactured from hardened spring steel. Presses over pilot to give quick release of core piece after cut.



Product Number	To Suit Saw Diameter	Weight each	Order Code KEN-050	Price/1 TB
K7	14 to 210mm	10g	-1970K	88.00

Variable Pitch Bi-Metal HSS Holesaw Kits

For producing high quality holes in wood, steel, brass, bronze, cast iron, aluminium and plastic. Featuring a very aggressive cutting action and M3 HSS cutting teeth to give a very smooth finish. Cuts up to 40% faster than constant pitch saws. The varying tooth pitch gives substantial reductions in noise by disrupting harmonics produced when sawing materials such as tubing, angle etc. Improved swarf clearance is also achieved requiring less effort to complete each cut. Tooth life is greatly extended, as is battery life when used with a cordless drill. Suitable for all uses: engineering, construction and maintenance. **4 to 6 teeth per inch. 28.5mm (1 1/8") cutting depth.**

Service Engineer's Kit 9 Piece

Comprises of 22, 29, 35, 44, 51 and 64mm variable pitch bi-metal high speed steel holesaws with hardened cutting edges, K7 spring, K4 and K10 arbors with pilot drills. Supplied in a robust plastic carry case.

Electrician's Kit 9 Piece

Comprises of 16, 20, 25, 32, 40 and 51mm variable pitch bi-metal high speed steel holesaws with hardened cutting edges, K7 Spring, K1 and K10 arbors with pilot drills. Supplied in a robust plastic carry case.



VARIABLE PITCH FOR IMPROVED ACTION

9 PIECES

Number of Pieces	Weight each	Order Code KEN-050	Price/1 TB
9	110g	-2400K	3826.00



9 PIECES

Number of Pieces	Weight each	Order Code KEN-050	Price/1 TB
9	90g	-2300K	3444.00

Tradesman's Compact Kits

High quality variable pitch bi-metal high speed steel holesaws with hardened cutting edges. Supplied in a handy storage tube. Ideal size to fit into power tool cases and tool boxes.

5 Piece: Comprises of 16, 20, 25 and 30mm holesaws with K1 arbor.

11 Piece: Comprises of 16, 19, 20, 22, 25, 30, 32, 38 and 51mm holesaws with K1 and K10 arbors.

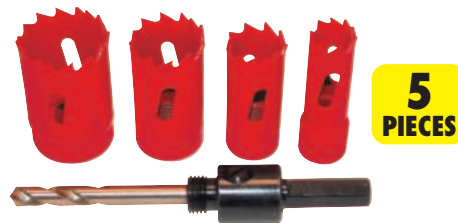

5 PIECES



VARIABLE PITCH FOR IMPROVED ACTION

11 PIECES

Storage tubes fit into power tool cases and tool boxes

Number of Pieces	Weight each	Order Code KEN-050	Price/1 TB
5	30g	-2100K	2351.00
11	160g	-2500K	3278.00

Constant Pitch Bi-Metal HSS Holesaw Kit

Featuring a constant pitch - First choice for cutting thin sheet materials up to 3mm thick. For producing high quality holes in wood, steel, brass, bronze, cast iron, aluminium and plastic. Featuring an hardened HSS cutting edge welded to a tough alloy steel body. Heavy duty shatter-resistant construction; virtually unbreakable. **6 teeth per inch. 38mm (1 1/2") cutting depth.**

9 Piece Service Engineer's Kit

Comprises of 22, 29, 35, 44, 51 and 64mm constant pitch bi-metal high speed steel holesaws with hardened cutting edges. Complete with K4 and K10 arbors and K7 Spring. Supplied in a robust plastic carry case.



9 PIECES

Number of Pieces	Weight each	Order Code KEN-050	Price/1 TB
9	1.20kg	-2000K	4481.00

GROUP 055 MASONRY DRILLS

KENNEDY Rotary Masonry Drill Bits
QUALITY INDUSTRIAL TOOLING

Tungsten carbide tipped with roll forged flutes. A general purpose mortar and masonry drill bit suitable for workshop and maintenance. Manufactured to **DIN 8039**.



CUTTING TOOLS

Standard Length



75.0mm to 120.0mm Length

Diameter	Overall Length	Weight each	Order Code KEN-055	Price/1 TB
No.6 (4.0mm)	75.0	6g	-0060K	26.00
No.8 (5.0mm)	85.0	10g	-0080K	26.00
No.10 (5.5mm)	85.0	14g	-0100K	26.00
No.10A (6.0mm)	100.0	14g	-0110K	31.00
No.12 (6.5mm)	100.0	17g	-0120K	37.00

Diameter	Overall Length	Weight each	Order Code KEN-055	Price/1 TB
No.14 (7.0mm)	100.0	17g	-0140K	42.00
No.16 (8.0mm)	120.0	27g	-0160K	47.00
No.18 (9.0mm)	120.0	28g	-0180K	52.00
No.20 (10.0mm)	120.0	40g	-0200K	57.00
No.23 (12.0mm)	120.0	55g	-0450K	67.00

Medium Length



150.0mm to 160.0mm Length

Diameter	Overall Length	Weight each	Order Code KEN-055	Price/1 TB
No. 8 (5.0mm)	150.0	17g	-1080K	37.00
No.10 (5.5mm)	150.0	22g	-1100K	37.00
No.10A (6.0mm)	150.0	22g	-1110K	47.00
No.12 (6.5mm)	150.0	50g	-1120K	57.00
No.14 (7.0mm)	150.0	25g	-1140K	67.00
No.16 (8.0mm)	150.0	34g	-1160K	73.00
No.18 (9.0mm)	150.0	35g	-1180K	83.00
No.20 (10.0mm)	150.0	50g	-1200K	93.00

Diameter	Overall Length	Weight each	Order Code KEN-055	Price/1 TB
No.22 (11.0mm)	150.0	50g	-1220K	98.00
No.24 (13.0mm)	150.0	84g	-1240K	102.00
No.25 (14.0mm)	150.0	100g	-1250K	102.00
No.26 (16.0mm)	150.0	128g	-1260K	109.00
No.27 (18.0mm)	160.0	132g	-1270K	114.00
No.28 (20.0mm)	160.0	195g	-1280K	140.00
No.29 (22.0mm)	160.0	245g	-1290K	308.00
No.30 (25.0mm)	160.0	308g	-1300K	309.00

Extra Length



300.0mm Length

Diameter	Overall Length	Weight each	Order Code KEN-055	Price/1 TB
No.12 (6.5mm)	300.0	58g	-3120K	67.00
No.14 (7.0mm)	300.0	58g	-3140K	78.00
No.16 (8.0mm)	300.0	91g	-3160K	88.00
No.20 (10.0mm)	300.0	98g	-3200K	98.00
No.22 (11.0mm)	300.0	130g	-3220K	155.00
No.24 (13.0mm)	300.0	164g	-3240K	181.00

400.0mm Length

Diameter	Overall Length	Weight each	Order Code KEN-055	Price/1 TB
No.16 (8.0mm)	400.0	124g	-4160K	191.00
No.18 (9.0mm)	400.0	125g	-4180K	196.00
No.20 (10.0mm)	400.0	130g	-4200K	201.00
No.22 (11.0mm)	400.0	174g	-4220K	206.00
No.24 (13.0mm)	400.0	219g	-4240K	217.00

Rotary Masonry Drill Bit Sets

7 Piece - Standard Length

Standard Length: No.6 x 75, No.8 x 85, No.10 x 85, No.10A x 100, No.12 x 100, No.16 x 120, No.20 x 120mm.

7 Piece - Standard & Medium Length

Standard Length:

- No.10 x 85,
- No.12 x 100,
- No.14 x 100,
- No.16 x 120,
- No.20 x 120.

**7
PIECES**

Medium Length:

- No.24 x 150,
- No.26 x 150mm.

16 Piece - Standard & Medium Length

Standard Length:

- No.6 x 75,
- No.8 x 85,
- No.10 x 85,
- No.10A x 100,
- No.14 x 100,
- No.16 x 120,
- No.18 x 120,
- No.20 x 120.

Medium Length:

- No.8 x 150,
- No.10 x 150,
- No.10A x 150,
- No.14 x 150,
- No.16 x 150,
- No.18 x 150,
- No.20 x 150,
- No.24 x 150mm.

**16
PIECES**



Number of Pieces	Weight each	Order Code KEN-055	Price/1 TB
7 - Standard	140g	-5070K	258.00
7 - Standard & Medium	400g	-5170K	361.00
16 - Standard & Medium	460g	-5320K	567.00

KOBE Tile & Masonry Drill Sets

2 Piece Sets

Two piece sets for drilling through glass, tiles, mirrors and ceramics.

Set contents:

1x masonry drill bit and 1x tile and glass drill bit.

**2
PIECES**

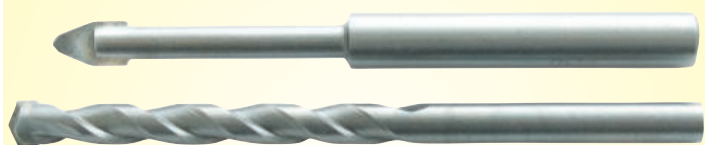

Diameter	Order Code KBE-280	Price/1 TB
5.00mm	-7500K	205.00
6.00mm	-7510K	258.00
6.50mm	-7520K	273.00
7.00mm	-7530K	284.00
8.00mm	-7540K	308.00

Tile & Glass Drill Set

Three piece drill bit set for drilling through glass, tiles, mirrors and ceramics.

**3
PIECES**

Contents:

5, 6 and 8mm.

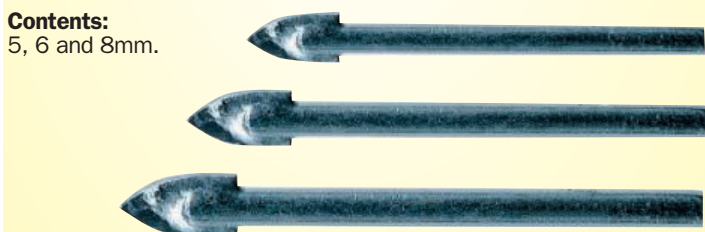

Number of Pieces	Order Code KBE-280	Price/1 TB
3	-7560K	308.00

KENNEDY *SDS-Style Fitting Hammer Drill Bits*
QUALITY INDUSTRIAL TOOLING

Tungsten carbide tipped and suitable for all SDS direct fitting hammer drills. High performance drill bits that withstand extreme heat generation ensuring maximum performance coupled with wear resistance. Manufactured to **DIN 8035**.



Diameter	Overall Length	Weight each	Order Code KEN-057	Price/1 TB
5.0mm	110.0	50g	-1000K	129.00
5.0mm	160.0	50g	-1020K	140.00
5.5mm	110.0	50g	-1200K	145.00
5.5mm	160.0	50g	-1220K	150.00
6.0mm	110.0	50g	-1400K	145.00
6.0mm	160.0	50g	-1420K	155.00
6.0mm	210.0	60g	-1440K	170.00
6.5mm	110.0	50g	-1600K	176.00
6.5mm	160.0	50g	-1620K	181.00
7.0mm	110.0	60g	-1800K	186.00
7.0mm	160.0	70g	-1820K	191.00
8.0mm	110.0	80g	-2000K	196.00
8.0mm	160.0	80g	-2020K	201.00
8.0mm	210.0	90g	-2040K	205.00
8.0mm	260.0	110g	-2080K	217.00
8.0mm	400.0	180g	-2120K	308.00
9.0mm	210.0	100g	-2240K	222.00
10.0mm	110.0	70g	-2400K	227.00
10.0mm	160.0	90g	-2420K	232.00
10.0mm	210.0	110g	-2440K	237.00
10.0mm	260.0	150g	-2480K	248.00
10.0mm	360.0	180g	-2520K	258.00
10.0mm	460.0	280g	-2540K	309.00
11.0mm	160.0	110g	-2620K	248.00
11.0mm	300.0	130g	-2680K	273.00
12.0mm	166.0	100g	-2820K	308.00
12.0mm	216.0	130g	-2840K	335.00
12.0mm	316.0	170g	-2900K	361.00
12.0mm	466.0	240g	-2940K	412.00
12.0mm	600.0	350g	-2980K	567.00
13.0mm	166.0	110g	-3020K	335.00

Diameter	Overall Length	Weight each	Order Code KEN-057	Price/1 TB
13.0mm	210.0	100g	-3040K	412.00
13.0mm	466.0	300g	-3140K	617.00
14.0mm	166.0	155g	-3220K	411.00
14.0mm	216.0	170g	-3240K	438.00
14.0mm	266.0	180g	-3280K	514.00
14.0mm	316.0	200g	-3300K	464.00
14.0mm	466.0	300g	-3340K	670.00
14.0mm	600.0	410g	-3380K	979.00
15.0mm	166.0	200g	-3420K	464.00
15.0mm	266.0	200g	-3480K	514.00
15.0mm	450.0	250g	-3540K	926.00
16.0mm	250.0	150g	-3640K	541.00
16.0mm	300.0	200g	-3700K	644.00
16.0mm	450.0	350g	-3740K	670.00
16.0mm	600.0	450g	-3760K	823.00
17.0mm	200.0	160g	-3840K	721.00
18.0mm	250.0	240g	-4040K	850.00
18.0mm	450.0	400g	-4140K	1029.00
20.0mm	200.0	200g	-4440K	926.00
20.0mm	300.0	300g	-4500K	1133.00
20.0mm	450.0	450g	-4540K	1236.00
22.0mm	250.0	350g	-4680K	1288.00
22.0mm	450.0	720g	-4740K	1391.00
24.0mm	250.0	390g	-4880K	1417.00
24.0mm	450.0	770g	-4940K	1544.00
25.0mm	250.0	430g	-5080K	1441.00
25.0mm	450.0	770g	-5140K	1606.00
26.0mm	250.0	430g	-5280K	1442.00
26.0mm	450.0	850g	-5340K	1853.00

SDS-Style Fitting Drill Bit Sets

Tungsten carbide tipped and suitable for all SDS direct fitting hammer drills. High performance drill bits that withstand extreme heat generation ensuring maximum performance coupled with wear resistance. Manufactured to **DIN 8035**.

7 Piece

5, 6 and 8mm x 110mm overall length.
6, 8, 10 and 12mm x 160mm overall length.

9 Piece

5, 5.5, 6 and 7mm x 160mm overall length.
8 x 210mm, 8 x 260mm, 12 x 216mm,
12 x 316mm and 16 x 250mm overall length.



Number of Pieces	Order Code KEN-057	Price/1 TB
7	-7000K	617.00
9	-7020K	1288.00

KOBE Diamond Core Drill Kit

Diamond laser welded core drills are a dry cutting, high performance diamond Core Drill. For use with arbor and guide rod (hex shank or SDS Plus) plus extension, if required.

Manufactured from tool grade steel for perfect concentricity. Can be used across a wide range of building materials such as: facing bricks, concrete blocks, breeze blocks, building blocks, hand made bricks and soft to medium hard natural stones. Mounting thread is R^{1/2}". Best results are achieved using an 850W (or higher) rotary drill with up to 300rpm, variable speed control and a slipping clutch for overload protection.



Number of Pieces	Core Drill Sizes (mm)	Order Code KBE-280	Price/1 TB
12	42, 52, 65, 117, 127	-0300K	9269.00

Individual Diamond Core Drills

Effective Length (mm)	Cutting Dia. (mm)	Order Code KBE-280	Price/1 TB
150	42	-0310K	1545.00
	52	-0312K	1648.00
	65	-0314K	1803.00
	117	-0316K	2266.00
	127	-0318K	3399.00

PRODUCTS ARE ONLY AVAILABLE VIA YOUR DISTRIBUTOR

GROUP 061 SHANK MILLING CUTTERS



HSS Threaded Shank Woodruff Cutters

HSS

12mm/1/2" Shank Ø

Produces closed slots for woodruff keys to **DIN 6888**.
For milling structural, carburising and heat treated steel up to 900N/mm².
Manufactured to **BS 122 : Part 4 : 1980**.
Made to **DIN 850**. Shank to **DIN 1835/D**.



Metric Limits of Tolerances

Diameter	+ 0.000	-0.127
Width		
2 up to 4	- 0.014	-0.028
4 up to 7	- 0.020	-0.038
7mm up	- 0.025	-0.047

Inch Limits of Tolerance

Diameter	+0.015"	-0.100"
Width	+0.000"	-0.001"



Metric Sizes

Diameter (mm)	Width	Overall Length	Weight each	Order Code SHR-061	Price/1 TB
10.5	2.0	57.0	44g	-6500A	2744.00
10.5	3.0	57.0	44g	-6502C	3415.00
11.0	3.5	54.0	11g	-6502J	3863.00
13.5	2.5	57.0	44g	-6504E	3914.00
13.5	3.0	57.0	45g	-6505F	3217.00
13.5	4.0	57.0	45g	-6506G	4097.00
16.5	3.0	57.0	46g	-6508J	5408.00
16.5	4.0	57.0	46g	-6509K	5029.00
16.5	5.0	57.0	46g	-6510L	5029.00
19.5	3.0	57.0	46g	-6511M	4571.00
19.5	4.0	57.0	46g	-6512N	4544.00
19.5	5.0	57.0	50g	-6513P	6077.00
19.5	6.0	57.0	51g	-6514C	6953.00
22.5	4.0	63.5	55g	-6514Q	5871.00
22.5	5.0	63.5	57g	-6515R	5974.00
22.5	6.0	63.5	59g	-6516S	5665.00
25.5	6.0	70.0	67g	-6518V	6592.00
25.5	8.0	70.0	73g	-6520X	6489.00
32.5	6.0	70.0	81g	-6527D	7519.00

HSS Plain Shank Woodruff Cutters

12mm/1/2" Shank Ø

Produces closed slots for woodruff keys to **DIN 6888**.
For milling structural, carburising and heat treated steel up to 900N/mm².
Manufactured to **BS 122 : Part 4 : 1980**.
Made to **DIN 850**.



HSS

Metric Limits of Tolerances

Diameter	+ 0.000	-0.127
Width		
2 up to 4	- 0.014	-0.028
4 up to 7	- 0.020	-0.038
7mm up	- 0.025	-0.047



Metric Sizes

Diameter (mm)	Width	Overall Length	Weight each	Order Code SHR-061	Price/1 TB
10.5	2.0	57.0	44g	-4500A	2833.00
10.5	3.0	57.0	44g	-4502C	3554.00
13.5	2.5	57.0	44g	-4504E	3914.00
13.5	3.0	57.0	45g	-4505F	3348.00
13.5	4.0	57.0	45g	-4506G	4275.00
16.5	3.0	57.0	46g	-4508J	5665.00
16.5	4.0	57.0	46g	-4509K	5305.00
16.5	5.0	57.0	46g	-4510L	5305.00
19.5	3.0	57.0	46g	-4511M	4790.00
19.5	4.0	57.0	46g	-4512N	4790.00
19.5	5.0	57.0	50g	-4513P	6386.00
19.5	6.0	57.0	51g	-4514C	7313.00
22.5	4.0	63.5	55g	-4514Q	6179.00
22.5	6.0	63.5	59g	-4516S	6283.00
25.5	6.0	70.0	67g	-4518V	6901.00
25.5	8.0	70.0	73g	-4520X	6901.00
32.5	6.0	70.0	81g	-4527D	7931.00

HSS Threaded Shank T-Slot Cutters

HSS

Used for machining T-slots on slide tables, fixtures etc. to **DIN 650**. For milling structural, carburising and heat treated steel up to 900N/mm². Sizes up to 16mm and 1/2" have six flutes and 18mm and 5/8" upwards have eight flutes.
Made to **DIN 851**. Shank to **DIN 1835/D**.

Flute form 12° RH/LH

Metric Limits of Tolerance

Diameter	+0.13 - 0.13
Length	+0.13 - 0.13

Inch Limits of Tolerance

Diameter	+0.005" - 0.005"
Length	+0.005" - 0.005"



Metric Sizes

Bolt Size	Head Depth	Diameter			Overall Length	Weight each	Order Code SHR-061	Price/1 TB
		Cutter	Shank	Neck				
M6.0	6.0	12.5	10.0	5.0	57.0	36g	-6550A	3164.00
M8.0	8.0	16.0	10.0	6.5	62.0	41g	-6551B	4070.00
M10.0	8.0	18.0	12.0	8.0	65.0	50g	-6552C	4696.00
M12.0	10.0	22.0	12.0	10.0	74.0	52g	-6553D	5511.00
M14.0	11.0	25.0	16.0	12.0	82.0	84g	-6554E	6335.00
M16.0	12.0	28.0	16.0	13.0	85.0	159g	-6555F	7107.00
M18.0	14.0	32.0	25.0	15.0	90.0	347g	-6556G	8549.00
M20.0	16.0	36.0	25.0	17.0	103.0	298g	-6557H	13648.00

HSS Plain Shank T-Slot Cutters

HSS

Used for machining T-slots on slide tables, fixtures etc. to **DIN 650**. For milling structural, carburising and heat treated steel up to 900N/mm². Sizes up to 16mm and 1/2" have six flutes and 18mm and 5/8" upwards have eight flutes.
Made to **DIN 851**.

Flute form 12° RH/LH

Metric Limits of Tolerance

Diameter	+0.13 - 0.13
Length	+0.13 - 0.13

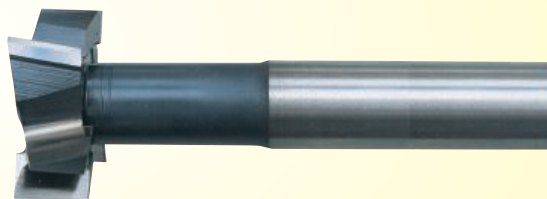

Metric Sizes

Bolt Size	Head Depth	Diameter			Overall Length	Weight each	Order Code SHR-061	Price/1 TB
		Cutter	Shank	Neck				
M6.0	6.0	12.5	10.0	5.0	57.0	36g	-4550A	1844.00
M8.0	8.0	16.0	10.0	6.5	62.0	41g	-4551B	2091.00
M10.0	8.0	18.0	12.0	8.0	65.0	50g	-4552C	2524.00
M12.0	10.0	22.0	12.0	10.0	74.0	52g	-4553D	3193.00
M14.0	11.0	25.0	16.0	12.0	82.0	84g	-4554E	5125.00
M16.0	12.0	28.0	16.0	13.0	85.0	159g	-4555F	7324.00
M18.0	14.0	32.0	25.0	15.0	90.0	347g	-4556G	9013.00
M20.0	16.0	36.0	25.0	17.0	103.0	298g	-4557H	14317.00



HSS Threaded Shank Dovetail Cutters (Single Angle Cutters)

Designed to produce dovetail slideways in machine tool tables, jigs and fixtures. Bright finish, straight helix. Made to **DIN 1833**. Shank to **DIN 1835D**.



HSS

Metric Limits of Tolerance

+0.25 - 0.00

Inch Limits of Tolerance

+0.010 - 0.000

45° Corner Angle - Metric (Form C)

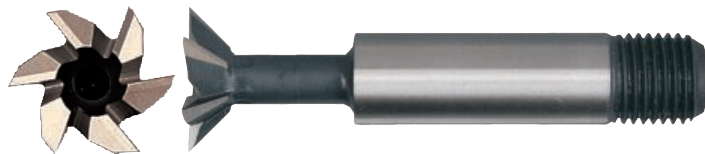

Diameter (mm)	Cut Length	Shank Dia.	Overall Length	Number of Teeth	Order Code SHR-061	Price/1 TB
13.0	3.0	12.0	63.5	6	-6200A	3534.00
16.0	4.0	12.0	66.5	6	-6201B	4145.00
19.0	5.5	12.0	66.5	6	-6202C	4626.00
25.0	7.5	12.0	70.0	8	-6204E	6644.00
32.0	8.5	16.0	74.5	8	-6206G	8807.00

60° Corner Angle - Metric (Form C)



Diameter (mm)	Cut Length	Shank Dia.	Overall Length	Number of Teeth	Order Code SHR-061	Price/1 TB
13.0	4.0	12.0	63.5	6	-6150A	1427.00
16.0	5.5	12.0	66.5	6	-6151B	2060.00
19.0	7.0	12.0	66.5	6	-6152C	1906.00
20.0	8.0	12.0	63.0	6	-6152P	2009.00
25.0	12.0	12.0	70.0	8	-6154E	2627.00
32.0	13.5	16.0	74.5	8	-6156G	8807.00

HSS Threaded Shank Corner Rounding Cutters

HSS

Designed to produce convex corner radii. For milling structural, carburizing and heat treated steel up to 900N/mm². Manufactured to works standards. 5° RH Flutes. Bright finish, straight helix. Radii tolerance: ± 0.005". Shank to **DIN 1835/D**.

HSS Plain Shank Corner Rounding Cutters

HSS

Designed to produce convex corner radii. For milling structural, carburizing and heat treated steel up to 900N/mm². Manufactured to works standards. 5° RH Flutes. Bright finish, straight helix. Radii tolerance: ± 0.005".



Metric Sizes

Radius (mm)	Head Dia.	Shank Dia.	Overall Length	Number of Teeth	Weight each	Order Code SHR-061	Price/1 TB
2.0	12.0	12.0	60.5	4	50g	-6408Z	2241.00
3.0	12.0	12.0	60.5	4	50g	-6410A	3033.00
4.0	14.0	12.0	60.5	4	54g	-6411B	4176.00
5.0	16.0	16.0	60.5	4	86g	-6412C	3603.00
6.0	22.0	16.0	63.5	4	109g	-6413D	5091.00
8.0	25.0	25.0	73.0	4	250g	-6414E	6386.00
10.0	28.0	25.0	79.5	4	272g	-6415F	8189.00
12.0	35.0	25.0	82.5	4	325g	-6416G	12103.00

Metric Sizes

Radius (mm)	Head Dia.	Shank Dia.	Overall Length	Number of Teeth	Weight each	Order Code SHR-061	Price/1 TB
2.0	12.0	12.0	60.5	4	50g	-4408Z	2318.00
3.0	12.0	12.0	60.5	4	50g	-4410A	3142.00
4.0	14.0	12.0	60.5	4	54g	-4411B	4378.00
5.0	16.0	16.0	60.5	4	86g	-4412C	3760.00
6.0	22.0	16.0	63.5	4	109g	-4413D	5356.00
8.0	25.0	25.0	73.0	4	250g	-4414E	6747.00
10.0	28.0	25.0	79.5	4	272g	-4415F	8601.00
12.0	35.0	25.0	82.5	4	325g	-4416G	12669.00

HSS Plain Shank Dovetail Cutters (Single Angle Cutters)

Designed to produce dovetail slideways in machine tool tables, jigs and fixtures. Bright finish, straight helix. Made to **DIN 1833**.

Ø Tolerances

Metric	Inch
+0.25 - 0.00	+0.010 - 0.000

HSS

45° Corner Angle - Metric (Form C)

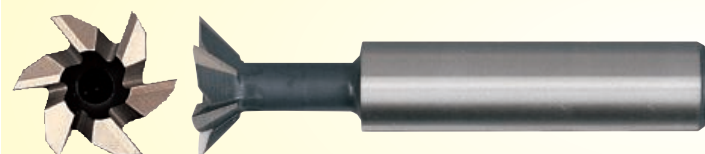

Diameter (mm)	Cut Length	Shank Dia.	Overall Length	Number of Teeth	Order Code SHR-061	Price/1 TB
13.0	3.0	12.0	63.5	6	-4200A	3708.00
16.0	4.0	12.0	66.5	6	-4201B	4326.00
19.0	5.5	12.0	66.5	6	-4202C	4841.00
20.0	5.5	12.0	62.0	6	-4202P	5202.00
25.0	7.5	12.0	70.0	8	-4204E	6953.00
32.0	8.5	16.0	74.5	8	-4206G	10146.00

60° Corner Angle - Metric (Form C)

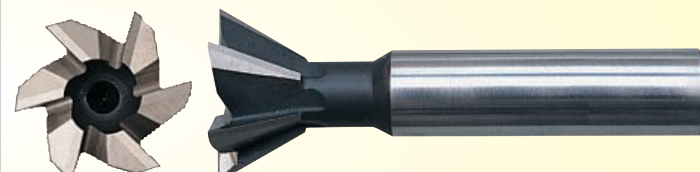

Diameter (mm)	Cut Length	Shank Dia.	Overall Length	Number of Teeth	Order Code SHR-061	Price/1 TB
13.0	4.0	12.0	63.5	6	-4150A	3502.00
16.0	5.5	12.0	66.5	6	-4151B	4275.00
19.0	7.0	12.0	66.5	6	-4152C	4841.00
20.0	8.0	12.0	63.0	6	-4152P	5202.00
25.0	12.0	12.0	70.0	8	-4154E	6953.00
32.0	13.5	16.0	74.5	8	-4156G	9219.00

SHANK MILLING CUTTERS



Plain Shank Milling Cutters 2 Flute

HSS-Co

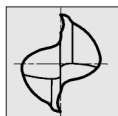

Centre cutting, used for profile milling, milling keyways and producing open slots.
Surface treatment: bright finish.
Flute helix 30°. Dimensions to **DIN 844**.
Plain shank to **DIN 1835A**.

Regular Length



Dia. (mm)	Flute Length	Overall Length	Shank Dia.	Order Code SHR-061	Price/1 TB
3.00	8	52	6	-3803A	1009.00
4.00	11	55	6	-3804B	1009.00
5.00	13	57	6	-3805C	1009.00
6.00	13	57	6	-3806D	1009.00
7.00	16	66	10	-3807E	1698.00
8.00	19	69	10	-3808F	1486.00
10.00	22	72	10	-3810H	1486.00
12.00	26	83	12	-3812K	1858.00
14.00	26	83	16	-3814M	2176.00
16.00	32	92	16	-3816P	2441.00
18.00	32	92	16	-3818R	3077.00
20.00	38	104	20	-3820S	3449.00
22.00	38	104	20	-3822T	6101.00
25.00	45	121	25	-3825V	5835.00

Long Series



Dia. (mm)	Flute Length	Overall Length	Shank Dia.	Order Code SHR-061	Price/1 TB
3.00	12	56	6	-3955C	931.00
4.00	19	63	6	-3957E	931.00
5.00	24	68	6	-3959G	931.00
6.00	24	68	6	-3961J	931.00
8.00	38	88	10	-3962K	1313.00
10.00	45	95	10	-3963L	1313.00
12.00	53	110	12	-3964M	1592.00
14.00	53	110	12	-3965N	2295.00
16.00	63	123	16	-3966P	2295.00
20.00	75	141	20	-3968R	3979.00

Plain Shank Milling Cutters 2 Flute Ball Nose

Centre cutting, used for profile milling, milling keyways and producing open slots.
Surface treatment: bright finish.
Flute helix 30°. Dimensions to **DIN 844**.
Plain shank to **DIN 1835A**.

HSS-Co

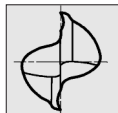

Regular Length



Dia. (mm)	Flute Length	Overall Length	Shank Dia.	Order Code SHR-061	Price/1 TB
3.00	5	49	6	-3982C	1040.00
4.00	7	51	6	-3984E	1040.00
5.00	8	52	6	-3986G	1040.00
6.00	8	52	6	-3988J	1040.00
8.00	11	61	10	-3992N	1531.00
10.00	13	63	10	-3996S	1531.00
12.00	16	73	12	-3998V	1914.00
14.00	16	73	12	-4000X	3605.00
16.00	19	79	16	-4002Z	4223.00
18.00	19	79	16	-4004B	5665.00
20.00	22	88	20	-4006D	6283.00
22.00	22	88	20	-4008F	6386.00
25.00	26	102	25	-4011J	7725.00

Plain Shank Milling Cutters 4 Flute

Centre cutting, used for profile milling, milling keyways and producing open slots.
Flute helix 30°. Dimensions to **DIN 844**.
Plain shank to **DIN 1835A**.

HSS-Co



Regular Length



Dia. (mm)	Flute Length	Overall Length	Shank Dia.	Order Code SHR-061	Price/1 TB
3.00	8	52	6	-3703A	903.00
3.50	11	55	6	-3703F	903.00
4.00	11	55	6	-3704B	903.00
4.50	13	57	6	-3704G	903.00
5.00	13	57	6	-3705C	903.00
5.50	13	57	6	-3705H	903.00
6.00	13	57	6	-3706D	903.00
6.50	19	69	10	-3706J	903.00
7.00	19	69	10	-3707E	903.00
7.50	19	69	10	-3707K	903.00
8.00	19	69	10	-3708F	903.00
8.50	22	72	10	-3708L	927.00
9.00	22	72	10	-3709Q	1327.00
9.50	22	72	10	-3709W	1339.00
10.00	22	72	10	-3710G	1009.00
10.50	22	79	12	-3710N	1442.00
11.00	22	79	12	-3711V	1545.00
12.00	26	83	12	-3712H	1236.00
13.00	26	83	12	-3713J	1648.00
14.00	26	83	12	-3714J	1906.00
15.00	32	92	16	-3715K	1957.00
16.00	32	92	16	-3716L	2009.00
17.00	32	92	16	-3717V	2833.00
18.00	32	92	16	-3718M	2833.00
19.00	32	92	16	-3719V	3605.00
20.00	38	104	20	-3720N	3605.00
22.00	38	104	20	-3722P	3979.00
25.00	45	121	25	-3725R	4456.00
26.00	45	121	25	-3726S	4635.00
28.00	45	121	25	-3728V	6180.00
30.00	45	121	25	-3730X	7725.00

Long Series



Dia. (mm)	Flute Length	Overall Length	Shank Dia.	Order Code SHR-061	Price/1 TB
3.00	12	56	6	-3873A	876.00
4.00	19	63	6	-3875C	876.00
5.00	24	68	6	-3877E	876.00
6.00	24	68	6	-3879G	876.00
7.00	38	88	10	-3879M	1751.00
8.00	38	88	10	-3880H	1258.00
9.00	38	88	10	-3880V	1910.00
10.00	45	95	10	-3881J	1262.00
11.00	53	110	12	-3881P	1700.00
12.00	53	110	12	-3882K	1700.00
13.00	53	110	12	-3882Q	2163.00
14.00	53	110	12	-3883K	2295.00
15.00	63	123	16	-3883Q	2653.00
16.00	63	123	16	-3884M	2295.00
18.00	63	123	16	-3885N	4775.00
20.00	75	141	20	-3886P	3979.00
22.00	75	141	20	-3888Q	4192.00
25.00	90	166	25	-3891T	4635.00



HSS-Co 5% Threaded Shank Slot Drills

Flute helix 30°. Manufactured to **BS 122:4**

Short Series

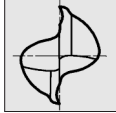

HSS-Co 5%

Dia. (mm)	Flute Length	Overall Length	Shank Dia.	Order Code SHR-061	Price/1 TB
1.50	2.5	48.5	6.0	-5664A	1591.00
2.00	3.0	49.0	6.0	-5665B	1150.00
2.50	4.5	51.0	6.0	-5666C	1445.00
3.00	7.0	51.0	6.0	-5667D	1150.00
3.50	7.5	52.5	6.0	-5668E	1445.00
4.00	9.5	52.5	6.0	-5669F	1150.00
5.00	9.5	52.5	6.0	-5671H	1150.00
5.50	11.0	55.5	6.0	-5672J	1445.00
6.00	11.0	56.5	6.0	-5673K	1150.00
6.50	11.0	58.5	10.0	-5674A	1410.00
7.00	11.0	58.5	10.0	-5674L	1111.00
7.50	11.0	58.5	10.0	-5675B	1693.00
8.00	12.5	59.5	10.0	-5675M	1090.00
8.50	14.5	60.5	10.0	-5676C	1751.00
9.00	14.5	60.5	10.0	-5676N	1217.00
9.50	14.5	60.5	10.0	-5677D	1854.00
10.00	14.5	60.5	10.0	-5677P	1192.00
10.50	17.5	65.0	12.0	-5678E	1648.00
11.00	17.5	65.0	12.0	-5678Q	1545.00
12.00	19.0	66.5	12.0	-5679R	1257.00
13.00	19.0	66.5	12.0	-5680G	1613.00
14.00	22.0	68.5	12.0	-5680S	1525.00
15.00	22.0	72.0	16.0	-5681H	2575.00
16.00	22.0	72.0	16.0	-5681T	1838.00
17.00	24.0	72.0	16.0	-5682J	2781.00
18.00	24.0	72.0	16.0	-5682V	2059.00
19.00	25.5	77.0	16.0	-5683K	2877.00
20.00	25.5	77.0	16.0	-5683W	2163.00
25.00	27.0	95.0	25.0	-5686A	4893.00
30.00	30.0	93.5	25.0	-5688C	7468.00

Long Series Type S231T



Dia. (mm)	Flute Length	Overall Length	Shank Dia.	Order Code SHR-061	Price/1 TB
3.00	11.0	60.5	6.0	-5855C	1557.00
4.00	12.5	66.5	6.0	-5857E	1557.00
5.00	12.5	70.0	6.0	-5859G	1557.00
6.00	16.0	76.0	6.0	-5861J	1557.00
6.50	16.0	76.0	10.0	-5861S	3399.00
7.00	16.0	76.0	10.0	-5862A	1503.00
8.00	19.0	79.5	10.0	-5862K	1503.00
9.00	22.0	82.5	10.0	-5863B	1836.00
10.00	22.0	82.5	10.0	-5863L	1520.00
11.00	22.0	82.5	12.0	-5863V	2524.00
12.00	25.5	95.0	12.0	-5864M	2163.00
14.00	28.5	101.5	12.0	-5865N	2369.00
15.00	31.5	108.0	16.0	-5865X	3605.00
16.00	31.5	108.0	16.0	-5866P	2472.00
18.00	35.0	114.5	16.0	-5867Q	3760.00
20.00	38.0	120.5	16.0	-5868R	3863.00

HSS-Co 5% Threaded Shank Slot Drills 3 Flute

Bright finish. Flute helix 30°. Manufactured to **BS 122: Part 4: 1980.**

Regular Series Type 5321T



Dia. (mm)	Flute Length	Overall Length	Shank Dia.	Order Code SHR-061	Price/1 TB
3.00	9.5	54.0	6.0	-6021A	1574.00
3.50	12.5	57.0	6.0	-6021C	1701.00
4.00	12.5	57.0	6.0	-6021E	1578.00
4.50	12.5	57.0	6.0	-6021G	1813.00
5.00	16.0	60.5	6.0	-6021J	1560.00
5.50	16.0	60.5	6.0	-6021L	2002.00
6.00	16.0	60.5	6.0	-6021N	1572.00
8.00	19.0	63.5	10.0	-6021Q	1990.00

HSS-Co 5% Threaded Shank End Mills

Used for profile milling and producing open slots. Bright finish. Flute helix 30°. Manufactured to **BS 122 : Part 4 : 1980.**

HSS-Co 5%



Regular Series Type E411T



Dia. (mm)	Flute Length	Overall Length	Shank Dia.	Order Code SHR-061	Price/1 TB
4 Flute					
2.00	4.0	51.0	6.0	-5185A	1700.00
2.50	6.5	51.0	6.0	-5186B	2009.00
3.00	9.5	54.0	6.0	-5187C	1133.00
4.00	12.5	57.0	6.0	-5189E	1133.00
5.00	16.0	60.5	6.0	-5191G	1133.00
6.00	16.0	60.5	6.0	-5193J	1133.00
6.50	16.0	60.5	10.0	-5193R	1494.00
7.00	15.0	60.5	10.0	-5193X	1133.00
8.00	18.0	63.5	10.0	-5194K	979.00
8.50	21.0	66.5	10.0	-5194S	1648.00
9.00	21.0	66.5	10.0	-5194Y	1133.00
9.50	21.0	66.5	10.0	-5195D	1906.00
10.00	21.0	66.5	10.0	-5195L	927.00
11.00	19.0	66.5	12.0	-5195Z	1592.00
12.00	24.0	70.0	12.0	-5196M	1288.00
13.00	24.5	70.0	12.0	-5197F	2163.00
14.00	28.5	73.5	12.0	-5197N	1906.00
15.00	26.5	77.0	16.0	-5198G	2163.00
16.00	26.5	80.0	16.0	-5198P	1803.00
17.00	32.0	80.0	16.0	-5199H	2884.00
18.00	35.0	88.0	16.0	-5199Q	2112.00
19.00	38.0	83.5	16.0	-5200J	3039.00
20.00	38.0	84.5	16.0	-5200R	2575.00
6 Flute					
25.00	41.5	101.5	25.0	-5202T	4069.00
30.00	46.0	104.5	25.0	-5204W	6232.00

Long Series Type E431T



Dia. (mm)	Flute Length	Overall Length	Shank Dia.	Order Code SHR-061	Price/1 TB
4 Flute					
3.00	19.0	63.5	6.0	-5473A	1236.00
4.00	25.5	70.0	6.0	-5475C	1236.00
5.00	31.5	76.0	6.0	-5477E	1236.00
6.00	31.5	76.0	6.0	-5479G	1236.00
8.00	34.0	79.5	10.0	-5480H	1128.00
10.00	37.0	82.5	10.0	-5481J	1339.00
12.00	49.5	95.0	12.0	-5482K	1442.00
14.00	57.0	101.5	12.0	-5483L	2575.00
16.00	58.5	108.5	16.0	-5484M	2781.00
18.00	70.0	115.0	16.0	-5485N	3605.00
20.00	76.0	121.5	16.0	-5486P	3863.00
6 Flute					
25.00	100.0	157.0	25.0	-5488R	4635.00

HSS-Co 5%

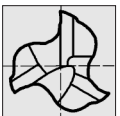

Dia. (mm)	Flute Length	Overall Length	Shank Dia.	Order Code SHR-061	Price/1 TB
10.00	22.0	66.5	10.0	-6021S	2180.00
12.00	25.5	71.5	12.0	-6021V	2573.00
14.00	28.5	74.5	12.0	-6021X	3223.00
16.00	32.0	80.0	16.0	-6021Z	3862.00
18.00	35.0	83.5	16.0	-6022B	4384.00
20.00	38.0	90.0	16.0	-6022D	5118.00
25.00	43.0	108.0	25.0	-6022K	8652.00
30.00	46.0	108.0	25.0	-6022R	10815.00



**HSS-Co 5% Threaded Shank
Coarse Pitch Roughing Cutters**

Knuckle Form

For use when heavy metal removal and good surface finish are required. Bright finish. Flute type: 25° spiral, roughing truncated. Shank diameter to **js14**.

**HSS-Co 5%
COARSE PITCH**

Standard Series K412T

Metric Tolerances		Inch Tolerances	
Diameter	± 0.127mm	Diameter	± 0.005"



Diameter (mm)	Flute Length	Overall Length	Shank Dia.	Number of Flutes	Weight each	Order Code SHR-061	Price/1 TB
6.00	16.0	60.5	6.0	3	26g	-6701A	4203.00
8.00	18.0	63.5	10.0	3	66g	-6702B	4338.00
10.00	21.0	66.5	10.0	3	85g	-6705E	4902.00
12.00	24.0	70.0	12.0	4	116g	-6708H	5025.00
14.00	28.5	73.0	12.0	4	131g	-6710K	6283.00
16.00	26.0	77.0	16.0	4	212g	-6714P	7004.00
18.00	35.0	80.0	16.0	4	282g	-6716R	7674.00
20.00	38.0	83.5	25.0	4	300g	-6717S	7674.00
25.00	44.5	101.5	25.0	5	332g	-6722Y	11382.00
30.00	46.0	104.5	25.0	6	418g	-6729E	15347.00

**HSS-EV Threaded Shank
Coarse Pitch Ripper Cutters**

HSS-EV

COARSE PITCH

Industrial quality for shaping and forming metal components. Four flute ripper cutters. Manufactured from sintered HSS-EV extra vanadium steel. Knuckle form, **h8** tolerance, standard length. Shank to **DIN 1835B**.

Regular Series



Diameter (mm)	Flute Length	Overall Length	Shank Dia.	Number of Flutes	Weight each	Order Code SHR-061	Price/1 TB
6.00	13.0	57.0	6.0	4	13g	-2540A	999.00
8.00	19.0	69.0	10.0	4	35g	-2541B	1067.00
10.00	22.0	72.0	10.0	4	37g	-2542C	1082.00
12.00	26.0	83.0	12.0	4	71g	-2543D	1473.00
16.00	32.0	92.0	16.0	4	131g	-2544E	2133.00
20.00	38.0	104.0	20.0	4	228g	-2545F	2534.00
25.00	45.0	121.0	25.0	4	407g	-2546G	2730.00

HSS-Co 5% Threaded Shank Coarse Pitch Roughing Cutters

Knuckle Form

For use when high metal removal rates area required. Bright finish. Flute type: 25° spiral, roughing truncated. Shank diameter to **js14**.

Long Series Type K432T



Diameter (mm)	Flute Length	Overall Length	Shank Dia.	Number of Flutes	Weight each	Order Code SHR-061	Price/1 TB
10.00	37.0	82.5	10.0	3	44g	-6760A	4307.00
12.00	49.5	95.0	12.0	4	69g	-6763D	5081.00
16.00	58.5	108.5	16.0	4	139g	-6769K	7674.00

**HSS-EV Threaded Shank
Fine Pitch Ripper Cutters**



HSS-EV

FINE PITCH

Four flute ripper cutters. Manufactured from sintered HSS-EV extra vanadium steel. Knuckle form, **h8** tolerance. Standard length. Dimensions to **DIN 844**. Shank to **DIN 1835D**.

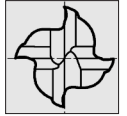

Regular Series

Dia. (mm)	Flute Length	Overall Length	Shank Dia.	No. of Flutes	Weight each	Order Code SHR-061	Price/1 TB
6.00	15.0	58.0	6.0	4	13g	-2600A	1740.00
8.00	20.0	70.0	10.0	4	36g	-2601B	1819.00
10.00	28.0	75.0	10.0	4	36g	-2602C	1789.00
12.00	33.0	85.0	12.0	4	71g	-2603D	1836.00
16.00	38.0	90.0	16.0	4	131g	-2604E	2547.00
20.00	47.0	110.0	20.0	4	228g	-2605F	2769.00
25.00	52.0	125.0	25.0	4	401g	-2606G	3990.00

HSS-EV TiCN Coated Screwed Shank Fine Pitch Ripper Cutters

HSS-EV

TiCN

FINE PITCH

Four flute ripper cutters. Manufactured from sintered HSS-EV extra vanadium steel. Knuckle form, **h8** tolerance. Dimensions to **DIN 844**. Shank to **DIN 1835B**.

Regular Series



Dia. (mm)	Flute Length	Overall Length	Shank Dia.	No. of Flutes	Weight each	Order Code SHR-061	Price/1 TB
8.00	20.0	70.0	10.0	4	35g	-2801B	2059.00
10.00	28.0	75.0	10.0	4	37g	-2802C	2163.00
12.00	33.0	85.0	12.0	4	71g	-2803D	2266.00
16.00	38.0	90.0	16.0	4	131g	-2804E	3224.00
20.00	47.0	110.0	20.0	4	228g	-2805F	3605.00
25.00	52.0	125.0	25.0	4	407g	-2806G	4635.00

HSS-Co 5%

COARSE PITCH



HSS-Co 8% Weldon Shank Slot Drills 2 Flute

Centre cutting. Weldon shank to **DIN 1835B**.
Cutting diameter to **e8**. Shank diameter to **h6**.

HSS-Co 8%

TiCN



HSS-Co 8% Uncoated

For general production machining.

HSS-Co 8% TiCN Coated

Extends cutter tool life and improves work material surface finish.

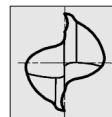

Series 01

Short Series Dimensions to **DIN 327**



SDH-2WS HSS-Co 8% SDN-2WS TiCN Coated

Diameter (mm)	Flute Length	Shank Diameter	Overall Length	Weight per 10	Order Code SWT-163	Price/1 TB	Order Code SWT-163	Price/1 TB
2.00	4.0	6.0	48.0	104g	-0102A	743.00	-	-
2.50	5.0	6.0	49.0	108g	-0102L	743.00	-0132L	955.00
3.00	5.0	6.0	49.0	110g	-0103A	743.00	-0133A	955.00
4.00	7.0	6.0	51.0	112g	-0104A	743.00	-0134A	955.00
4.50	7.0	6.0	51.0	114g	-0104L	743.00	-	-
5.00	8.0	6.0	52.0	117g	-0105A	849.00	-0135A	1327.00
6.00	8.0	6.0	52.0	121g	-0106A	743.00	-0136A	955.00
7.00	10.0	10.0	60.0	336g	-0107A	955.00	-	-
8.00	11.0	10.0	61.0	345g	-0108A	955.00	-0138A	1380.00
9.00	11.0	10.0	61.0	355g	-0109A	1115.00	-	-
10.00	13.0	13.0	63.0	476g	-0110A	1009.00	-0140A	1486.00
11.00	13.0	12.0	70.0	587g	-0111A	1221.00	-	-
12.00	16.0	12.0	73.0	613g	-0112A	1167.00	-0142A	1645.00
13.00	16.0	12.0	73.0	616g	-0113A	1539.00	-	-
14.00	16.0	12.0	73.0	615g	-0114A	1433.00	-0144A	1858.00
15.00	16.0	12.0	73.0	654g	-0115A	1645.00	-	-
16.00	19.0	16.0	79.0	1025g	-0116A	1645.00	-0146A	2122.00
18.00	19.0	16.0	79.0	1086g	-0118A	1910.00	-	-
20.00	22.0	20.0	88.0	1423g	-0120A	2228.00	-	-

Series 02

Regular Series Dimensions to **DIN 844**



Diameter (mm)	Flute Length	Shank Diameter	Overall Length	Weight per 10	SDH-2WR HSS-Co 8%		SDN-2WR TiCN Coated	
					Order Code SWT-163	Price/1 TB	Order Code SWT-163	Price/1 TB
2.00	7.0	6.0	51.0	108g	-0202A	1115.00	-	-
3.00	8.0	6.0	52.0	108g	-0203A	1009.00	-	-
4.00	11.0	6.0	55.0	114g	-0204A	1009.00	-0234A	1221.00
5.00	13.0	6.0	57.0	121g	-0205A	1115.00	-	-
6.00	13.0	6.0	57.0	150g	-0206A	1009.00	-0236A	1327.00
8.00	19.0	10.0	69.0	361g	-0208A	1221.00	-0238A	1698.00
10.00	22.0	10.0	72.0	402g	-0210A	1380.00	-0240A	1804.00
12.00	26.0	12.0	83.0	652g	-0212A	1539.00	-0242A	1804.00
14.00	26.0	12.0	83.0	710g	-0214A	1964.00	-	-
16.00	32.0	16.0	92.0	950g	-0216A	2334.00	-0246A	2865.00
20.00	38.0	20.0	104.0	2114g	-0220A	2865.00	-	-
25.00	45.0	25.0	121.0	2400g	-0225A	3820.00	-	-

Series 03

Long Series Dimensions to **DIN 844**



Diameter (mm)	Flute Length	Shank Diameter	Overall Length	Weight per 10	SDH-2WL HSS-Co 8%		SDN-2WL TiCN Coated	
					Order Code SWT-163	Price/1 TB	Order Code SWT-163	Price/1 TB
2.00	7.0	6.0	54.0	110g	-0302A	955.00	-	-
3.00	8.0	6.0	56.0	116g	-0303A	903.00	-	-
4.00	11.0	6.0	63.0	120g	-0304A	1221.00	-	-
6.00	13.0	6.0	68.0	153g	-0306A	1115.00	-0336A	1486.00
8.00	19.0	10.0	88.0	442g	-0308A	1592.00	-0338A	2228.00
10.00	22.0	10.0	95.0	528g	-0310A	1858.00	-0340A	2494.00
12.00	26.0	12.0	110.0	736g	-0312A	2228.00	-0342A	2918.00
16.00	32.0	16.0	123.0	1734g	-0316A	3661.00	-	-
20.00	38.0	20.0	141.0	3064g	-0320A	4192.00	-	-

SWISS+TECH *HSS-Co 8% Weldon Shank Slot Drills 3 Flute*

HSS-Co 8%

TiCN

TiALN



Centre cutting. Weldon shank to **DIN 1835B**.
Cutting diameter to **e8**.
Shank diameter to **h6**.

HSS-Co 8% Uncoated

For general production machining.

HSS-Co 8% TiCN Coated

Extends cutter tool life and improves work material surface finish.

HSS-Co 8% TiALN Coated

Dissipates and resists heat, reduces surface friction coupled with high surface hardness.



Series 05
Short Series Dimensions to **DIN 327**



Diameter (mm)	Flute Length	Shank Diameter	Overall Length	Weight per 10	SDH-3WS HSS-Co 8%		SDN-3WS TiCN Coated		SDL-3WS TiALN Coated	
					Order Code SWT-163	Price/1 TB	Order Code SWT-163	Price/1 TB	Order Code SWT-163	Price/1 TB
2.00	4.0	6.0	48.0	107g	-0502A	797.00	-0532A	1061.00	-0562A	1115.00
3.00	5.0	6.0	49.0	109g	-0503A	797.00	-0533A	1009.00	-0563A	1009.00
4.00	7.0	6.0	51.0	112g	-0504A	797.00	-0534A	1009.00	-0564A	1009.00
5.00	8.0	6.0	52.0	117g	-0505A	903.00	-0535A	1009.00	-0565A	1009.00
6.00	8.0	6.0	52.0	123g	-0506A	797.00	-0536A	1009.00	-0566A	1009.00
7.00	10.0	10.0	60.0	339g	-0507A	1221.00	-0537A	1698.00	-	-
8.00	11.0	10.0	61.0	353g	-0508A	903.00	-0538A	1433.00	-0568A	1433.00
9.00	11.0	10.0	61.0	355g	-0509A	1486.00	-	-	-	-
10.00	13.0	10.0	63.0	382g	-0510A	1115.00	-0540A	1486.00	-0570A	1486.00
12.00	16.0	12.0	73.0	617g	-0512A	1274.00	-0542A	1698.00	-0572A	1698.00
14.00	16.0	12.0	73.0	688g	-0514A	1592.00	-0544A	2070.00	-0574A	2388.00
16.00	19.0	16.0	79.0	1220g	-0516A	1804.00	-0546A	2282.00	-0576A	2282.00
20.00	22.0	20.0	88.0	1894g	-0520A	1804.00	-0550A	3343.00	-	-
25.00	26.0	25.0	102.0	3388g	-0525A	4616.00	-	-	-	-



Series 06
Regular Series Dimensions to **DIN 844**



Diameter (mm)	Flute Length	Shank Diameter	Overall Length	Weight per 10	SDH-3WR HSS-Co 8%		SDN-3WR TiCN Coated		SDL-3WR TiALN Coated	
					Order Code SWT-163	Price/1 TB	Order Code SWT-163	Price/1 TB	Order Code SWT-163	Price/1 TB
3.00	8.0	6.0	52.0	111g	-0603A	955.00	-0633A	1115.00	-0663A	1115.00
4.00	11.0	6.0	55.0	114g	-0604A	955.00	-0634A	1115.00	-0664A	1115.00
5.00	13.0	6.0	57.0	129g	-0605A	955.00	-0635A	1221.00	-0665A	1221.00
6.00	13.0	6.0	57.0	128g	-0606A	903.00	-0636A	1115.00	-0666A	1115.00
7.00	16.0	10.0	66.0	340g	-	-	-0637A	2122.00	-	-
8.00	19.0	10.0	69.0	368g	-0608A	1115.00	-0638A	1486.00	-0668A	1486.00
9.00	19.0	10.0	69.0	-	-0609A	1486.00	-0639A	1854.00	-	-
10.00	22.0	10.0	72.0	404g	-0610A	1274.00	-0640A	1698.00	-0670A	1698.00
11.00	22.0	12.0	79.0	-	-0611A	1698.00	-0641A	2122.00	-	-
12.00	26.0	12.0	83.0	666g	-0612A	1433.00	-0642A	1804.00	-0672A	1804.00
13.00	26.0	12.0	83.0	-	-0613A	2388.00	-	-	-	-
14.00	26.0	12.0	83.0	710g	-0614A	1751.00	-0644A	2122.00	-0674A	2122.00
16.00	32.0	16.0	92.0	950g	-0616A	1964.00	-0646A	2334.00	-0676A	2334.00
18.00	32.0	16.0	92.0	-	-0618A	3343.00	-	-	-	-
20.00	38.0	20.0	104.0	2114g	-0620A	2971.00	-0650A	3767.00	-0680A	3767.00
25.00	45.0	25.0	121.0	2400g	-0625A	4775.00	-	-	-	-



Series 07
Long Series Dimensions to **DIN 844**



Diameter (mm)	Flute Length	Shank Diameter	Overall Length	Weight per 5	SDH-3WL HSS-Co 8%		SDN-3WL TiCN Coated	
					Order Code SWT-163	Price/1 TB	Order Code SWT-163	Price/1 TB
3.00	12.0	6.0	56.0	49g	-0703A	1115.00	-0733A	1380.00
4.00	19.0	6.0	63.0	59g	-0704A	1115.00	-0734A	1486.00
5.00	24.0	6.0	68.0	69g	-0705A	1115.00	-0735A	1486.00
6.00	24.0	6.0	68.0	72g	-0706A	1167.00	-0736A	1486.00
8.00	38.0	10.0	88.0	206g	-0708A	1327.00	-0738A	1964.00
10.00	45.0	10.0	95.0	245g	-0710A	1486.00	-0740A	2122.00
12.00	53.0	12.0	110.0	379g	-0712A	1698.00	-0742A	2388.00
14.00	53.0	12.0	110.0	420g	-0714A	2122.00	-	-
16.00	63.0	16.0	123.0	746g	-0716A	2653.00	-0746A	3608.00
20.00	75.0	20.0	141.0	1314g	-0720A	3873.00	-	-
22.00	75.0	20.0	141.0	1425g	-0722A	3926.00	-	-
25.00	90.0	25.0	166.0	2415g	-0725A	5677.00	-	-



HSS-Co 8% Weldon Shank End Mills 4 & 6 Flute

HSS-Co 8%

TiCN

TiAlN



Centre cutting. Weldon shank to **DIN 1835B**.
Shank cutting diameter
3 - 6mm to +0.04 -0.0.
8 - 20mm to +0.05 -0.0.

HSS-Co 8% Uncoated

For general production machining.

HSS-Co 8% TiCN Coated

Extends cutter tool life and improves work material surface finish.

HSS-Co 8% TiAlN Coated

Dissipates and resists heat, reduces surface friction coupled with high surface hardness.

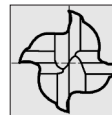

Series 09

Regular Series Dimensions to **DIN 844**



Diameter (mm)	Flute Length	Shank Diameter	Overall Length	No. of Flutes	Weight per 10	EMH-4WR HSS-Co 8%		EMN-4WR TiCN Coated		EML-4WR TiAlN Coated	
						Order Code SWT-163	Price/1 TB	Order Code SWT-163	Price/1 TB	Order Code SWT-163	Price/1 TB
2.00	7.0	6.0	51.0	4	108g	-0902A	955.00	-0932A	1221.00	-0962A	1274.00
3.00	8.0	6.0	52.0	4	111g	-0903A	955.00	-0933A	1221.00	-0963A	1274.00
4.00	11.0	6.0	55.0	4	117g	-0904A	955.00	-0934A	1221.00	-0964A	1274.00
5.00	13.0	6.0	57.0	4	126g	-0905A	1167.00	-0935A	1380.00	-0965A	1433.00
6.00	13.0	6.0	57.0	4	133g	-0906A	955.00	-0936A	1221.00	-0966A	1274.00
7.00	16.0	10.0	66.0	4	332g	-0907A	1221.00	-	-	-	-
8.00	19.0	10.0	69.0	4	375g	-0908A	1167.00	-0938A	1698.00	-0968A	1751.00
9.00	19.0	10.0	69.0	4	-	-0909A	1167.00	-	-	-	-
10.00	22.0	10.0	72.0	4	423g	-0910A	1327.00	-0940A	1804.00	-0970A	1804.00
11.00	22.0	12.0	79.0	4	-	-0911A	1486.00	-	-	-	-
12.00	26.0	12.0	83.0	4	688g	-0912A	1486.00	-0942A	1964.00	-0972A	2016.00
13.00	26.0	12.0	83.0	4	-	-0913A	1858.00	-	-	-	-
14.00	26.0	12.0	83.0	4	725g	-0914A	1858.00	-	-	-0974A	2334.00
15.00	26.0	12.0	83.0	4	-	-0915A	2070.00	-	-	-	-
16.00	32.0	16.0	92.0	4	1037g	-0916A	2070.00	-0946A	2547.00	-0976A	2600.00
17.00	32.0	16.0	92.0	4	-	-0917A	2600.00	-	-	-	-
18.00	32.0	16.0	92.0	4	1390g	-0918A	2600.00	-	-	-0978A	2600.00
19.00	32.0	16.0	92.0	4	-	-0919A	3131.00	-	-	-	-
20.00	38.0	20.0	104.0	4	2114g	-0920A	3131.00	-0950A	4032.00	-0980A	4032.00
25.00	45.0	25.0	121.0	6	2400g	-0925A ⁽¹⁾	5623.00	-0955A ⁽²⁾	6578.00	-0985A ⁽³⁾	6578.00

⁽¹⁾ EMH-6WR HSS-Co 8%

⁽²⁾ EMN-6WR TiCN Coated

⁽³⁾ EML-6WR TiAlN Coated



Series 10

Long Series Dimensions to **DIN 844**



Diameter (mm)	Flute Length	Shank Diameter	Overall Length	No. of Flutes	Weight per 5	EMH-4WL HSS-Co 8%		EMN-4WL TiCN Coated		EML-4WL TiAlN Coated	
						Order Code SWT-163	Price/1 TB	Order Code SWT-163	Price/1 TB	Order Code SWT-163	Price/1 TB
3.00	12.0	6.0	56.0	4	55g	-1003A	1167.00	-1033A	1433.00	-1063A	1486.00
4.00	19.0	6.0	63.0	4	61g	-1004A	1167.00	-1034A	1486.00	-1064A	1486.00
5.00	24.0	6.0	68.0	4	67g	-1005A	1167.00	-1035A	1486.00	-1065A	1486.00
6.00	24.0	6.0	68.0	4	74g	-1006A	1221.00	-1036A	1539.00	-1066A	1486.00
8.00	38.0	10.0	88.0	4	215g	-1008A	1380.00	-1038A	1910.00	-1068A	1964.00
10.00	45.0	10.0	95.0	4	260g	-1010A	1486.00	-1040A	2016.00	-1070A	2016.00
12.00	53.0	12.0	110.0	4	408g	-1012A	1804.00	-1042A	2282.00	-1072A	2282.00
14.00	53.0	12.0	110.0	4	471g	-1014A	2282.00	-1044A	2918.00	-1074A	2918.00
16.00	63.0	16.0	123.0	4	806g	-1016A	2759.00	-1046A	3449.00	-1076A	3449.00
20.00	75.0	20.0	141.0	4	1433g	-1020A	4085.00	-1050A	5199.00	-1080A	5199.00

HSS-Co 8% Weldon Shank Ball Nose Slot Drills 2 Flute

Centre cutting.
Weldon shank to **DIN 1835B**.
Cutting diameter to **e8**.
Shank diameter to **h6**.

HSS-Co 8%

TiCN

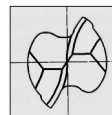
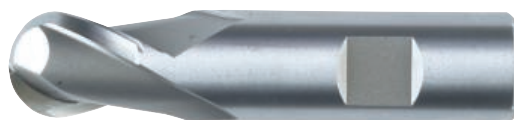

Series 11

Short Series Dimensions to **DIN 327**



Diameter (mm)	Flute Length	Shank Diameter	Overall Length	Weight per 5	SBH-2WS HSS-Co 8%		SBN-2WS TiCN Coated	
					Order Code SWT-163	Price/1 TB	Order Code SWT-163	Price/1 TB
2.00	5.0	6.0	49.0	52g	-1102A	1804.00	-	-
3.00	5.0	6.0	49.0	54g	-1103A	1804.00	-	-
4.00	7.0	6.0	51.0	55g	-1104A	1804.00	-1134A	1964.00
5.00	8.0	6.0	52.0	58g	-1105A	1804.00	-	-
6.00	8.0	6.0	52.0	60g	-1106A	1804.00	-1136A	2070.00
8.00	11.0	10.0	61.0	170g	-1108A	1964.00	-1138A	2494.00
10.00	13.0	10.0	63.0	188g	-1110A	2176.00	-1140A	2653.00
12.00	16.0	12.0	73.0	306g	-1112A	2653.00	-1142A	3183.00
16.00	19.0	16.0	79.0	535g	-1116A	3449.00	-1146A	3979.00
20.00	22.0	20.0	88.0	944g	-1120A	4192.00	-	-

SWISS+TECH

HSS-Co 8%



HSS-Co 8% Weldon Shank 42° High Helix Slot Drills 2 Flute For Aluminium

For general production machining.
Centre cutting.
Weldon shank to **DIN 1835B**.
Shank cutting diameter to +0.04 -0.0.

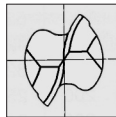

Series 15 Regular Length Dimensions to DIN 844

Diameter (mm)	Flute Length	Shank Diameter	Overall Length	Weight per 5	Order Code SWT-163	Price/1 TB
3.00	8.0	6.0	52.0	55g	-1503A	1115.00
4.00	11.0	6.0	55.0	56g	-1504A	955.00
5.00	13.0	6.0	57.0	60g	-1505A	955.00
6.00	13.0	6.0	57.0	62g	-1506A	1009.00
8.00	19.0	10.0	69.0	175g	-1508A	1167.00
10.00	22.0	10.0	72.0	190g	-1510A	1380.00
12.00	26.0	12.0	83.0	326g	-1512A	1539.00
16.00	32.0	16.0	92.0	603g	-1516A	2070.00
20.00	38.0	20.0	104.0	1054g	-1520A	3289.00

HSS-Co 8% Weldon Shank Coarse Pitch Ripper Cutters

HSS-Co 8%



For general production machining.
Centre cutting.
Weldon shank to **DIN 1835B**.
Cutting diameter to **js12**.
Shank diameter to **h6**.

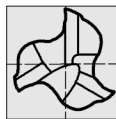

Series 17 Regular Series Dimensions to DIN 844

Diameter (mm)	Flute Length	Shank Diameter	Overall Length	No. of Flutes	Weight per 10	Order Code SWT-163	Price/1 TB
6.00	13.0	6.0	57.0	3	129g	-1706A ⁽¹⁾	1433.00
8.00	19.0	10.0	69.0	3	311g	-1708A ⁽¹⁾	1751.00
10.00	22.0	10.0	72.0	4	337g	-1710A	1804.00
12.00	26.0	12.0	83.0	4	690g	-1712A	1964.00
16.00	32.0	16.0	92.0	4	1280g	-1716A	2600.00
20.00	38.0	20.0	104.0	4	2224g	-1720A	3555.00

⁽¹⁾ RCH-3WL HSS-Co 8%

HSS-Co 8% Weldon Shank Coarse Pitch Ripper Cutters

Centre cutting. Weldon shank to **DIN 1835B**.
Cutting diameter to **js12**.
Shank diameter to **h6**.

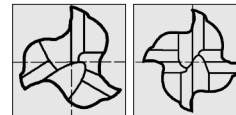

Series 18 Long Series Dimensions to DIN 844

Diameter (mm)	Flute Length	Shank Diameter	Overall Length	No. of Flutes	Weight per 5	Order Code SWT-163	Price/1 TB
8.00	38.0	10.0	88.0	3	215g	-1808A ⁽¹⁾	2441.00
10.00	45.0	10.0	95.0	4	259g	-1810A	2600.00
12.00	53.0	12.0	110.0	4	401g	-1812A	2918.00
16.00	63.0	16.0	123.0	4	804g	-1816A	3820.00
20.00	75.0	20.0	141.0	4	1132g	-1820A	5359.00
25.00	90.0	25.0	166.0	5	2627g	-1825A ⁽⁴⁾	7851.00

⁽¹⁾ RCH-3WL HSS-Co 8%

⁽⁴⁾ RCH-5WL HSS-Co 8%

HSS-Co 8% Weldon Shank Coarse Pitch 37° High Helix for Aluminium Roughing End Mills 3 Flute

Centre cutting. Weldon shank to **DIN 1835B**.
Shank diameter to **h6**.

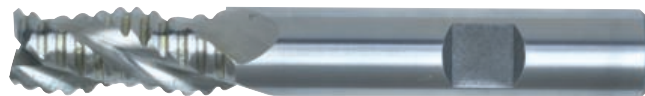

Series 20 Regular Length Dimensions to DIN 844

Diameter (mm)	Flute Length	Shank Diameter	Overall Length	Weight each	Order Code SWT-163	Price/1 TB
6.00	13.0	6.0	57.0	12g	-2006A	2334.00
8.00	19.0	10.0	69.0	36g	-2008A	2334.00
10.00	22.0	10.0	72.0	40g	-2010A	1910.00
12.00	26.0	12.0	83.0	67g	-2012A	2122.00
16.00	32.0	16.0	93.0	124g	-2016A	3399.00
20.00	38.0	20.0	104.0	215g	-2020A	3767.00

HSS-Co 8% Weldon Shank Coarse Pitch 37° High Helix for Aluminium Roughing End Mills 3 Flute

Centre cutting. Weldon shank to **DIN 1835B**.
Shank diameter to **h6**.



Series 21 Long Series Dimensions to DIN 844

Diameter (mm)	Flute Length	Shank Diameter	Overall Length	Weight each	Order Code SWT-163	Price/1 TB
10.00	45.0	10.0	95.0	49g	-2110A	3300.00
12.00	53.0	12.0	110.0	78g	-2112A	2918.00
20.00	75.0	20.0	141.0	263g	-2120A	5359.00

FREE **SWISS+TECH**

Decimal Conversion Wall Chart (A2 Size)

AVAILABLE ON REQUEST

CAT-849-2189A

Contact your local branch or representative.

SWISS+TECH *HSS-Co 8% Weldon Shank Fine Pitch Ripper Cutters*

Centre cutting.
Weldon shank to **DIN 1835B**.
Cutting diameter to **js12**.
Shank diameter to **h6**.

HSS-Co 8% TiCN TiAlN

- HSS-Co 8% Uncoated** For general production machining.
- HSS-Co 8% TiCN Coated** Extends cutter tool life and improves work material surface finish.
- HSS-Co 8% TiAlN Coated** Dissipates and resists heat, reduces surface friction coupled with high surface hardness.



Series 25
Regular Series Dimensions to **DIN 844**



Diameter (mm)	Flute Length	Shank Diameter	Overall Length	No. of Flutes	Weight per 5	RFH-4WR HSS-Co 8%		RFN-4WR TiCN Coated		RFL-4WR TiAlN Coated	
						Order Code SWT-163	Price/1 TB	Order Code SWT-163	Price/1 TB	Order Code SWT-163	Price/1 TB
6.00	13.0	6.0	57.0	3	65g	-2506A ⁽¹⁾	2176.00	-2536A ⁽²⁾	2600.00	-2566A ⁽³⁾	2653.00
8.00	19.0	10.0	69.0	3	186g	-2508A ⁽¹⁾	2334.00	-2538A ⁽²⁾	2918.00	-2568A ⁽³⁾	2918.00
10.00	22.0	10.0	72.0	4	212g	-2510A	2600.00	-2540A	3131.00	-2570A	3131.00
12.00	26.0	12.0	83.0	4	356g	-2512A	2971.00	-2542A	3501.00	-2572A	3449.00
16.00	32.0	16.0	92.0	4	642g	-2516A	4138.00	-2546A	4668.00	-2576A	4668.00
20.00	38.0	20.0	104.0	4	1123g	-2520A	4138.00	-2550A	6632.00	-2580A	6632.00

⁽¹⁾ RFH-3WR HSS Co 8% ⁽²⁾ RFN-3WR TiCN Coated ⁽³⁾ RFL-3WR TiAlN Coated



Series 26
Long Series Dimensions to **DIN 844**



Diameter (mm)	Flute Length	Shank Diameter	Overall Length	No. of Flutes	Weight per 5	RFH-4WL HSS-Co 8%		RFN-4WL TiCN Coated	
						Order Code SWT-163	Price/1 TB	Order Code SWT-163	Price/1 TB
6.00	24.0	6.0	68.0	3	80g	-2606A ⁽¹⁾	2865.00	-	-
8.00	38.0	10.0	88.0	3	212g	-2608A ⁽¹⁾	2918.00	-2638A ⁽²⁾	2918.00
10.00	45.0	10.0	95.0	4	264g	-2610A	3449.00	-2640A	4085.00
12.00	53.0	12.0	110.0	4	408g	-2612A	4138.00	-2642A	4775.00
16.00	63.0	16.0	123.0	4	790g	-2616A	5889.00	-2646A	6684.00
20.00	75.0	20.0	141.0	4	1411g	-2620A	7851.00	-2650A	9284.00

⁽¹⁾ RFH-3WL HSS Co 8% ⁽²⁾ RFN-3WL TiCN Coated

SHERWOOD *HSS-E Weldon Shank Coarse Pitch Ripper Cutters*

Industrial quality for shaping and forming metal components.
4 flute ripper cutters.
Manufactured from sintered HSS-E extra vanadium steel.
Knuckle form, **h8** tolerance, standard length.
Shank to **DIN 1835D**.

COARSE PITCH HSS-EV



Regular Series

Dia. (mm)	Flute Length	Overall Length	Shank Dia.	No. of Flutes	Weight each	Order Code SHR-061	Price/1 TB
6.00	13.0	57.0	6.0	4	13g	-2560A	1067.00
8.00	19.0	69.0	10.0	4	36g	-2561B	1067.00
10.00	22.0	72.0	10.0	4	40g	-2562C	1082.00
12.00	26.0	83.0	12.0	4	71g	-2563D	1473.00
16.00	32.0	92.0	16.0	4	134g	-2564E	2133.00
20.00	38.0	104.0	20.0	4	221g	-2565F	2534.00
25.00	45.0	121.0	25.0	4	427g	-2566G	3605.00

HSS-EV Weldon Shank Fine Pitch Ripper Cutters

4 flute ripper cutters.
Manufactured from sintered HSS-EV extra vanadium steel.
Knuckle form, **h8** tolerance. Standard length.
Dimensions to **DIN 844**.
Shank to **DIN 1835D**.

FINE PITCH HSS-EV



Regular Series

Dia. (mm)	Flute Length	Overall Length	Shank Dia.	No. of Flutes	Weight each	Order Code SHR-061	Price/1 TB
6.00	15.0	58.0	6.0	4	16g	-2620A	1740.00
8.00	20.0	70.0	10.0	4	36g	-2621B	1819.00
10.00	28.0	75.0	10.0	4	41g	-2622C	1789.00
12.00	33.0	85.0	12.0	4	74g	-2623D	1836.00
16.00	38.0	90.0	16.0	4	125g	-2624E	2547.00
20.00	47.0	110.0	20.0	4	232g	-2625F	2769.00
25.00	52.0	125.0	25.0	4	402g	-2625G	3894.00

GROUP 061 SHANK MILLING CUTTERS

SWISS+TECH Carbide Plain Shank Milling Cutters

Centre cutting. To Manufacturers Standards.

HSS-Co 8% Uncoated

For general production machining.

HSS-Co 8% TiCN Coated

Extends cutter tool life and improves work material surface finish.

HSS-Co 8% TiAlN Coated

Dissipates and resists heat, reduces surface friction coupled with high surface hardness.



Series 45 2 Flute - Short Series Dimensions to **DIN 6535 HA**

Diameter (mm)	Flute Length	Overall Length	Shank Diameter	Weight each	SDC-2PS Carbide		SDT-2PS TiCN Coated	
					Order Code SWT-161	Price/1 TB	Order Code SWT-161	Price/1 TB
2.00	8.0	32.0	2.0	3g	-4502A	849.00	-4532A	1009.00
2.50	8.0	32.0	2.5	4g	-4502L	849.00	-	-
3.00	12.0	32.0	3.0	4g	-4503A	797.00	-	-
4.00	12.0	40.0	4.0	7g	-4504A	903.00	-	-
5.00	14.0	50.0	5.0	13g	-4505A	1327.00	-	-
6.00	16.0	50.0	6.0	18g	-4506A	1380.00	-4536A	1327.00
7.00	20.0	60.0	7.0	37g	-4507A	1858.00	-	-
8.00	20.0	60.0	8.0	37g	-4508A	1751.00	-4538A	2290.00
9.00	20.0	60.0	9.0	49g	-4509A	2441.00	-	-
10.00	22.0	70.0	10.0	68g	-4510A	2653.00	-4540A	3294.00
12.00	22.0	70.0	12.0	96g	-4512A	3926.00	-	-
14.00	25.0	75.0	14.0	134g	-4514A	5465.00	-	-
16.00	25.0	75.0	16.0	172g	-4516A	6438.00	-	-



Series 48 3 Flute - Short Series

Diameter (mm)	Flute Length	Overall Length	Shank Diameter	Weight each	SDC-3PS Carbide		SDT-3PS TiCN Coated	
					Order Code SWT-161	Price/1 TB	Order Code SWT-161	Price/1 TB
1.00	4.0	40.5	4.0	7g	-4801A	1029.00	-4831A	1115.00
1.50	4.5	40.0	4.0	7g	-4801L	1029.00	-4831L	1115.00
2.00	8.0	32.0	2.0	3g	-4802A	1029.00	-4832A	1115.00
2.50	8.0	32.0	2.5	3g	-4802L	1029.00	-4832L	1115.00
3.00	12.0	32.0	3.0	4g	-4803A	799.00	-4833A	1009.00
3.50	12.0	32.0	3.5	4g	-4803L	1115.00	-4833L	1380.00
4.00	12.0	40.0	4.0	7g	-4804A	955.00	-4834A	1221.00
4.50	12.0	50.0	4.5	11g	-4804L	1327.00	-4834L	1592.00
5.00	14.0	50.0	6.0	13g	-4805A	1327.00	-4835A	1592.00
5.50	16.0	50.0	6.0	16g	-4805L	1339.00	-	-
6.00	16.0	50.0	6.0	18g	-4806A	1380.00	-4836A	1592.00
6.50	20.0	50.0	8.0	25g	-4806L	1854.00	-	-
7.00	20.0	50.0	8.0	50g	-4807A	1804.00	-4837A	2176.00
7.50	20.0	60.0	8.0	55g	-4807L	1957.00	-	-
8.00	20.0	60.0	8.0	57g	-4808A	1751.00	-4838A	2122.00
9.00	20.0	60.0	9.0	60g	-4809A	2441.00	-	-
10.00	22.0	60.0	10.0	71g	-4810A	2706.00	-4840A	2971.00
12.00	22.0	60.0	12.0	100g	-4812A	3926.00	-4842A	4510.00
16.00	25.0	75.0	16.0	175g	-4816A	6335.00	-	-
20.00	32.0	100.0	20.0	367g	-4820A	10716.00	-	-



Series 50 4 Flute - Short Series

Diameter (mm)	Flute Length	Overall Length	Shank Diameter	Weight each	EMC-4PS Carbide		EMT-4PS TiCN Coated	
					Order Code SWT-161	Price/1 TB	Order Code SWT-161	Price/1 TB
2.00	8.0	32.0	2.0	3g	-5002A	876.00	-5032A	1115.00
2.50	8.0	32.0	2.5	3g	-5002L	876.00	-	-
3.00	12.0	32.0	3.0	4g	-5003A	823.00	-5033A	955.00
3.50	12.0	32.0	3.5	4g	-5003L	926.00	-	-
4.00	12.0	40.0	4.0	7g	-5004A	926.00	-5034A	1167.00
5.00	14.0	50.0	5.0	14g	-5005A	1327.00	-5035A	1592.00
6.00	16.0	50.0	6.0	19g	-5006A	1380.00	-5036A	1645.00
6.50	20.0	50.0	8.0	25g	-5006L	1853.00	-	-
7.00	20.0	60.0	7.0	49g	-5007A	1804.00	-5037A	2176.00
7.50	20.0	60.0	8.0	55g	-5007L	1803.00	-	-
8.00	20.0	60.0	8.0	57g	-5008A	1751.00	-5038A	2070.00
9.00	20.0	60.0	9.0	60g	-5009A	2833.00	-5039A	3554.00
10.00	20.0	70.0	10.0	71g	-5010A	2653.00	-5040A	2971.00
11.00	22.0	60.0	12.0	90g	-5011A	4119.00	-5041A	5099.00
12.00	22.0	70.0	12.0	102g	-5012A	3926.00	-5042A	4510.00
14.00	25.0	75.0	14.0	184g	-5014A	5465.00	-5044A	6101.00
16.00	25.0	75.0	16.0	386g	-5016A	6283.00	-5046A	6790.00
20.00	32.0	100.0	20.0	892g	-5020A	10716.00	-5050A	11830.00
25.00	46.0	150.0	25.0	895g	-5025A	16657.00	-5055A	17824.00

6 Piece Sets
Dimensions to **DIN 844**. Cutting diameter to **js12**.
Shank diameter to **h6**.

Contents: 3, 4, 5, 6, 8 and 10mm.

6 PIECES

CARBIDE

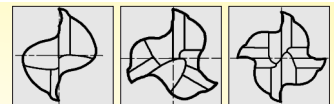

Number of Flutes	Series Number	Order Code SWT-161	Price/1 TB
2	45	-4526A	3237.00
3	48	-4890A	4775.00
4	50	-5028A	4893.00





CUTTING TOOLS



**Carbide Micrograin Plain Shank
Milling Cutters**

2 Flute

For optimum performance and maximum swarf removal when plunging, slotting and routing in light alloys, brass, aluminium, non-ferrous and other soft materials. Manufactured to **Works Standards**.

Diameter Metric	Tolerances				
	Tolerance		Tolerance		
	+	-	Diameter Inch	Tolerance	
Over 1.00 ~ up to 6.00	0.000	0.050	Over 1/16" ~ up to 1/4"	0.000	0.002
Over 6.00 ~ up to 25.00	0.000	0.080	Over 1/4" ~ up to 1"	0.000	0.003

Regular Series - Metric

Diameter (mm)	Flute Length	Overall Length	Shank Dia.	Weight each	Order Code KEN-161	Price/1 TB
1.00	3.0	40.0	4.0	15g	-0020K	639.00
1.50	4.0	40.0	4.0	15g	-0030K	639.00
2.00	8.0	32.0	2.0	15g	-0040K	639.00
2.50	8.0	32.0	2.5	15g	-0050K	824.00
3.00	12.0	32.0	3.0	15g	-0060K	639.00
3.50	12.0	32.0	3.5	20g	-0070K	773.00
4.00	12.0	40.0	4.0	20g	-0080K	773.00
4.50	14.0	50.0	4.5	20g	-0090K	979.00
5.00	14.0	50.0	5.0	30g	-0100K	979.00
6.00	16.0	50.0	6.0	35g	-0120K	1133.00
7.00	20.0	60.0	7.0	40g	-0140K	1442.00
8.00	20.0	60.0	8.0	40g	-0160K	1803.00
9.00	20.0	60.0	9.0	60g	-0180K	1803.00
10.00	22.0	70.0	10.0	100g	-0200K	2163.00
11.00	22.0	70.0	11.0	120g	-0220K	2637.00
12.00	22.0	70.0	12.0	130g	-0240K	2854.00
14.00	25.0	75.0	14.0	180g	-0280K	3966.00
16.00	25.0	75.0	16.0	230g	-0320K	4502.00
18.00	25.0	75.0	18.0	230g	-0360K	6562.00
20.00	32.0	100.0	20.0	240g	-0400K	12360.00



Regular Series - Inch

Diameter (inch)	Flute Length	Overall Length	Shank Dia.	Weight each	Order Code KEN-161	Price/1 TB
1/8"	1/2"	1 1/2"	1/8"	10g	-0580K	773.00
3/16"	5/8"	2"	3/16"	20g	-0620K	1133.00
1/4"	3/4"	2 1/2"	1/4"	30g	-0660K	1597.00
5/16"	13/16"	2 1/2"	5/16"	45g	-0700K	1906.00
3/8"	1"	2 1/2"	3/8"	60g	-0740K	2369.00
1/2"	1"	3"	1/2"	165g	-0820K	3966.00
3/4"	1 1/2"	4"	1"	640g	-0980K	8395.00

3 Flute

Centre cutting as standard. Offer a combination of advantages achieved with two and four flutes giving profile and peripheral milling capability in addition to slotting and plunging. Manufactured to **Works Standards**.

CARBIDE

Regular Series - Metric

Diameter (mm)	Flute Length	Overall Length	Shank Dia.	Weight each	Order Code KEN-161	Price/1 TB
1.00	3.0	40.0	4.0	15g	-3020K	913.00
1.50	4.5	40.0	4.0	15g	-3030K	913.00
2.00	8.0	32.0	2.0	15g	-3040K	913.00
2.50	8.0	32.0	2.5	15g	-3050K	934.00
3.00	12.0	32.0	3.0	15g	-3060K	797.00
3.50	12.0	32.0	3.5	20g	-3070K	1284.00
4.00	14.0	40.0	4.0	20g	-3080K	1284.00
4.50	14.0	50.0	4.5	20g	-3090K	1284.00
5.00	14.0	50.0	5.0	30g	-3100K	1380.00
6.00	16.0	50.0	6.0	35g	-3120K	1486.00
7.00	20.0	60.0	7.0	40g	-3140K	2006.00
8.00	20.0	60.0	8.0	40g	-3160K	1888.00
9.00	20.0	60.0	10.0	60g	-3180K	2547.00
10.00	22.0	70.0	10.0	100g	-3200K	2653.00
11.00	22.0	70.0	11.0	120g	-3220K	3109.00
12.00	22.0	70.0	12.0	130g	-3240K	3289.00
14.00	25.0	75.0	14.0	180g	-3280K	6748.00
16.00	25.0	75.0	16.0	230g	-3320K	7629.00
18.00	25.0	75.0	18.0	230g	-3360K	11246.00
20.00	32.0	100.0	20.0	240g	-3400K	15808.00
25.00	38.0	150.0	25.0	640g	-3500K	18354.00



Regular Series - Inch

Diameter (inch)	Flute Length	Overall Length	Shank Dia.	Weight each	Order Code KEN-161	Price/1 TB
1/16"	3/16"	1 1/2"	1/8"	10g	-3540K	913.00
3/32"	9/32"	1 1/2"	1/8"	10g	-3560K	913.00
1/8"	3/8"	1 1/2"	1/8"	10g	-3580K	797.00
3/16"	5/8"	2"	3/16"	20g	-3620K	1380.00
1/4"	3/4"	2 1/2"	1/4"	30g	-3660K	1486.00
5/16"	13/16"	2 1/2"	5/16"	45g	-3700K	1888.00
3/8"	1"	2 1/2"	3/8"	60g	-3740K	2653.00
1/2"	1"	3"	1/2"	140g	-3820K	3289.00
5/8"	1 1/4"	3 1/2"	5/8"	230g	-3900K	7629.00

4 Flute

Centre cutting as standard. For maximum strength when milling harder materials where rapid swarf removal is not needed. Four flute milling cutters have one of the strongest tooth structures available in solid cutters. Manufactured to **Works Standards**.

CARBIDE

Regular Series - Metric

Diameter (mm)	Flute Length	Overall Length	Shank Dia.	Weight each	Order Code KEN-161	Price/1 TB
1.00	3.0	40.0	4.0	15g	-6020K	913.00
1.50	4.5	40.0	4.0	15g	-6030K	913.00
2.00	8.0	32.0	2.0	15g	-6040K	913.00
2.50	9.5	32.0	2.5	15g	-6050K	934.00
3.00	12.0	32.0	3.0	15g	-6060K	797.00
3.50	12.0	32.0	3.5	20g	-6070K	1284.00
4.00	14.0	40.0	4.0	20g	-6080K	1125.00
4.50	14.0	50.0	4.5	20g	-6090K	1284.00
5.00	14.0	50.0	5.0	30g	-6100K	1380.00
6.00	16.0	50.0	6.0	35g	-6120K	1348.00
7.00	20.0	60.0	8.0	40g	-6140K	2006.00
8.00	20.0	60.0	8.0	40g	-6160K	1888.00
9.00	20.0	60.0	9.0	60g	-6180K	2547.00
10.00	22.0	70.0	10.0	100g	-6200K	2727.00
11.00	22.0	70.0	11.0	120g	-6220K	3109.00
12.00	22.0	70.0	12.0	130g	-6240K	3767.00
14.00	25.0	75.0	14.0	180g	-6280K	6748.00
16.00	25.0	75.0	16.0	230g	-6320K	7629.00
18.00	25.0	75.0	18.0	230g	-6360K	11246.00
20.00	32.0	100.0	20.0	240g	-6400K	15808.00
25.00	38.0	100.0	25.0	640g	-6500K	18354.00



Regular Series - Inch

Diameter (inch)	Flute Length	Overall Length	Shank Dia.	Weight each	Order Code KEN-161	Price/1 TB
1/16"	3/16"	1 1/2"	1/8"	10g	-6540K	871.00
3/32"	3/8"	1 1/2"	1/8"	10g	-6560K	828.00
1/8"	1/2"	1 1/2"	1/8"	10g	-6580K	765.00
3/16"	5/8"	2"	3/16"	20g	-6620K	1072.00
7/32"	5/8"	2 1/2"	1/4"	30g	-6640K	1486.00
1/4"	3/4"	2 1/2"	1/4"	30g	-6660K	1284.00
5/16"	13/16"	2 1/2"	5/16"	45g	-6700K	1794.00
3/8"	1"	2 1/2"	3/8"	60g	-6740K	2239.00
1/2"	1"	3"	1/2"	165g	-6820K	3586.00

PRODUCTS ARE ONLY AVAILABLE VIA YOUR DISTRIBUTOR

GROUP 061 SHANK MILLING CUTTERS



Carbide Micrograin Plain Shank Slot Drills

Long Series - 2 Flute

For optimum performance and maximum swarf removal when plunging, slotting and routing in most materials including brass, aluminium, non-ferrous and other soft materials. Manufactured to **USCTi Standards**.

Diameter Metric	Tolerances		Diameter Inch	Tolerance	
	+	-		+	-
Over 1.00 ~ up to 6.00	0.000	0.050	Over 1/16" ~ up to 1/4"	0.000	0.002
Over 6.00 ~ up to 25.00	0.000	0.080	Over 1/4" ~ up to 1"	0.000	0.003

CARBIDE



Long Series - Metric

Diameter (mm)	Flute Length	Overall Length	Shank Dia.	Weight each	Order Code KEN-161	Price/1 TB
3.00	20.0	60.0	3.0	15g	-1003K	1319.00
4.00	20.0	60.0	4.0	20g	-1004K	1391.00
5.00	25.0	75.0	5.0	30g	-1005K	1545.00
6.00	30.0	75.0	6.0	35g	-1006K	1824.00
8.00	30.0	75.0	8.0	40g	-1008K	2472.00
10.00	40.0	100.0	10.0	100g	-1010K	3657.00
12.00	45.0	100.0	12.0	130g	-1012K	4738.00
16.00	65.0	150.0	16.0	230g	-1016K	9178.00
20.00	65.0	150.0	16.0	240g	-1020K	12875.00

Long Series - 3 Flute



Long Series - Metric

Diameter (mm)	Flute Length	Overall Length	Shank Dia.	Weight each	Order Code KEN-161	Price/1 TB
3.00	25.0	75.0	3.0	15g	-4003K	1433.00
4.00	25.0	75.0	4.0	20g	-4004K	1539.00
5.00	25.0	75.0	6.0	30g	-4005K	1910.00
6.00	25.0	75.0	6.0	35g	-4006K	2016.00
8.00	25.0	75.0	8.0	40g	-4008K	2759.00
10.00	38.0	100.0	10.0	100g	-4010K	4032.00
12.00	50.0	100.0	12.0	130g	-4012K	5942.00
16.00	75.0	150.0	16.0	230g	-4016K	11564.00

Long Series - 4 Flute

CARBIDE



Long Series - Metric

Diameter (mm)	Flute Length	Overall Length	Shank Dia.	Weight each	Order Code KEN-161	Price/1 TB
3.00	20.0	60.0	3.0	15g	-9203K	1433.00
4.00	20.0	60.0	4.0	20g	-9204K	1592.00
5.00	25.0	75.0	5.0	30g	-9205K	1964.00
6.00	30.0	75.0	6.0	35g	-9206K	2070.00
8.00	30.0	75.0	8.0	40g	-9208K	2812.00
10.00	40.0	100.0	10.0	100g	-9210K	4032.00
12.00	45.0	100.0	12.0	130g	-9212K	5942.00
16.00	65.0	150.0	16.0	230g	-9216K	11564.00
20.00	65.0	150.0	20.0	240g	-9220K	22015.00



Carbide Micrograin Plain Shank Milling Cutters

For optimum performance and maximum swarf removal when plunging, slotting and routing in light alloys, brass, aluminium, non-ferrous and other soft materials. Manufactured to **USCTi Standards**. Two flute for maximum swarf clearance. Four flute for maximum rigidity. (Three flute price/1 a combination of the advantages achieved with two and four flutes.)

CARBIDE

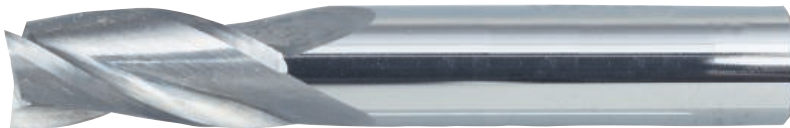

EXTENDED RANGE



Regular Series

Diameter (mm)	Flute Length	Overall Length	Shank Dia.	Weight each	2 FLUTE		3 FLUTE		4 FLUTE	
					Order Code SHR-161	Price/1 TB	Order Code SHR-161	Price/1 TB	Order Code SHR-161	Price/1 TB
1.50	5.0	39.0	3.0	15g	-0030K	541.00	-	-	-	-
2.00	7.0	39.0	3.0		-0040K	567.00	-3040K	590.00	-6040K	531.00
2.50	8.0	39.0	3.0		-0050K	593.00	-3050K	541.00	-6050K	582.00
3.00	10.0	39.0	3.0	15g	-0060K	464.00	-3060K	514.00	-6060K	531.00
3.50	12.0	51.0	4.0		-0070K	617.00	-3070K	670.00	-6070K	644.00
4.00	14.0	51.0	4.0	20g	-0080K	593.00	-3080K	644.00	-6080K	632.00
4.50	14.0	51.0	5.0		-0090K	1751.00	-3090K	979.00	-6090K	747.00
5.00	16.0	51.0	5.0	30g	-0100K	743.00	-3100K	876.00	-6100K	737.00
5.50	19.0	64.0	6.0		-	-	-3110K	1082.00	-	-
6.00	19.0	64.0	6.0	35g	-0120K	926.00	-3120K	1009.00	-6120K	979.00
6.50	19.0	70.0	8.0		-	-	-3130K	1288.00	-6130K	979.00
7.00	19.0	64.0	8.0	40g	-0140K	1082.00	-3140K	1167.00	-6140K	1141.00
8.00	21.0	64.0	8.0		-0160K	1167.00	-3160K	1274.00	-6160K	1152.00
8.50	22.0	70.0	10.0	60g	-	-	-3170K	1545.00	-6170K	1339.00
9.00	22.0	70.0	10.0		-0180K	1671.00	-3180K	1937.00	-6180K	1863.00
10.00	25.0	70.0	10.0	100g	-0200K	1964.00	-3200K	2070.00	-6200K	1957.00
11.00	25.0	70.0	11.0		-	-	-3220K	2575.00	-6220K	2575.00
12.00	25.0	76.0	12.0	130g	-0240K	2149.00	-3240K	2276.00	-6240K	2276.00
13.00	30.0	89.0	14.0		-	-	-3260K	2833.00	-	-
14.00	30.0	89.0	14.0	180g	-0280K	3449.00	-3280K	3311.00	-6280K	3242.00
15.00	32.0	89.0	15.0		-	-	-3300K	3451.00	-	-
16.00	32.0	89.0	16.0	230g	-0320K	4298.00	-3320K	4483.00	-6320K	4276.00
20.00	38.0	100.0	20.0		-0400K	7071.00	-3400K	7241.00	-6400K	7241.00

CUTTING TOOLS

SHANK MILLING CUTTERS



CARBIDE

Carbide Micrograin Plain Shank Slot Drills 2 Flute Ball Nosed

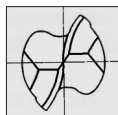

For optimum performance and maximum swarf removal when plunging, slotting and routing in most materials including brass, aluminium, non-ferrous and other soft materials. Manufactured to **USCTi Standards**.

Diameter Metric	Tolerances	
	+	-
Over 1.00 ~ up to 6.00	0.000	0.050
Over 6.00 ~ up to 25.00	0.000	0.080



Regular Series

Diameter (mm)	Flute Length	Overall Length	Shank Dia.	Weight each	Order Code SHR-161	Price/1 TB
2.00	4.0	38.0	3.0	10g	-1040K	691.00
3.00	6.0	38.0	3.0	10g	-1060K	600.00
4.00	8.0	50.0	4.0	15g	-1080K	797.00
5.00	10.0	50.0	6.0	25g	-1100K	876.00
6.00	12.0	50.0	6.0	25g	-1120K	1167.00
7.00	19.0	63.0	8.0	45g	-1140K	1274.00
8.00	20.0	63.0	8.0	55g	-1160K	1327.00
10.00	22.0	75.0	10.0	90g	-1200K	2228.00
12.00	25.0	75.0	12.0	120g	-1240K	2653.00
16.00	32.0	89.0	16.0	250g	-1320K	4828.00
20.00	38.0	100.0	20.0	420g	-1400K	8117.00

Solid Carbide Micrograin Plain Shank End Mills 4 Flute Ball Nosed



CARBIDE

For maximum strength when milling harder materials where rapid swarf removal is not needed. Four flute milling cutters have one of the strongest tooth structures available in solid cutters. Centre cutting as standard. Manufactured to **ANSI Standards**.

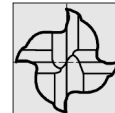

Diameter Metric	Tolerances	
	+	-
Over 1.00 ~ up to 6.00	0.000	0.050
Over 6.00 ~ up to 25.00	0.000	0.080

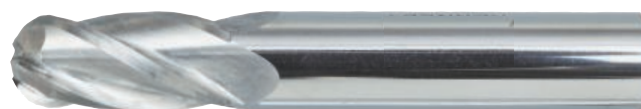

Regular Series

Diameter (mm)	Flute Length	Overall Length	Shank Dia.	Weight each	Order Code SHR-161	Price/1 TB
2.00	6.3	38.0	3.0	10g	-7040K	691.00
3.00	12.0	38.0	3.0	10g	-7060K	610.00
4.00	14.0	50.0	4.0	15g	-7080K	770.00
5.00	16.0	50.0	6.0	25g	-7100K	770.00
6.00	19.0	50.0	6.0	25g	-7120K	1141.00
8.00	20.0	63.0	8.0	55g	-7160K	2149.00
10.00	22.0	75.0	10.0	90g	-7200K	2149.00
12.00	25.0	75.0	12.0	120g	-7240K	2653.00
16.00	32.0	89.0	16.0	250g	-7320K	4965.00
20.00	38.0	100.0	20.0	420g	-7400K	6953.00

SWISS+TECH Carbide Plain Shank Slot Drills 2 Flute Ball Nosed

Centre cutting. To **Manufacturers Standards**.

CARBIDE TiCN



Carbide Uncoated

For general production machining.

TiCN Coated

Extends cutter tool life and improves work material surface finish.

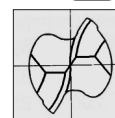

Series 53 Short Series



Diameter (mm)	Flute Length	Overall Length	Shank Diameter	Weight each	SBC-2PS Carbide		SBT-2PS TiCN Coated	
					Order Code SWT-161	Price/1 TB	Order Code SWT-161	Price/1 TB
2.00	4.0	48.0	6.0	17g	-5302A	1545.00	-	-
3.00	4.0	48.0	6.0	18g	-5303A	1288.00	-5333A	1167.00
4.00	6.0	50.0	6.0	19g	-5304A	1339.00	-5334A	1539.00
5.00	7.0	51.0	6.0	20g	-5305A	1645.00	-5335A	1910.00
6.00	7.0	51.0	6.0	20g	-5306A	1804.00	-5336A	2016.00
8.00	9.0	59.0	8.0	40g	-5308A	2176.00	-5338A	2547.00
10.00	10.0	60.0	10.0	63g	-5310A	3501.00	-5340A	3873.00

KENNEDY Solid Carbide Micrograin Plain Shank End Mills Double Ended

4 Flute
For maximum strength when milling harder materials where rapid swarf removal is not needed. Four flute milling cutters have one of the strongest tooth structures available in solid cutters. Centre cutting. Manufactured to **ANSI Standards**.



CARBIDE

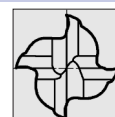

4 Flute - Regular Series - Metric

Diameter (mm)	Flute Length	Overall Length	Shank Dia.	Weight each	Order Code KEN-161	Price/1 TB	Diameter (mm)	Flute Length	Overall Length	Shank Dia.	Weight each	Order Code KEN-161	Price/1 TB
3.00	6.0	38.0	3.0	10g	-8060K	849.00	8.00	12.0	63.0	8.0	50g	-8160K	2122.00
4.00	8.0	50.0	4.0	15g	-8080K	1167.00	10.00	14.0	75.0	10.0	80g	-8200K	3183.00
5.00	10.0	63.0	5.0	20g	-8100K	1486.00	12.00	16.0	75.0	12.0	120g	-8240K	4456.00
6.00	12.0	63.0	6.0	30g	-8120K	1592.00							



**Carbide Micrograin Plain Shank Slot Drills
Ball Nosed**

2 Flute

For optimum performance and maximum swarf removal when plunging, slotting and routing in most materials including brass, aluminium, non-ferrous and other soft materials.
Manufactured to **USCTi Standards**.

Regular Series - 2 Flute



Regular Series - Metric

Diameter (mm)	Flute Length	Overall Length	Shank Dia.	Weight each	Order Code KEN-161	Price/1 TB
2.00	6.0	38.0	3.0	10g	-1040K	814.00
3.00	7.0	57.0	6.0	10g	-1060K	814.00
4.00	8.0	57.0	6.0	15g	-1080K	1056.00
5.00	10.0	57.0	6.0	25g	-1100K	1206.00
6.00	10.0	57.0	6.0	25g	-1120K	1494.00
7.00	19.0	63.0	8.0	45g	-1140K	1751.00
8.00	16.0	63.0	8.0	55g	-1160K	1803.00
10.00	19.0	75.0	10.0	90g	-1200K	2843.00
12.00	22.0	83.0	12.0	120g	-1240K	4120.00
16.00	26.0	92.0	16.0	250g	-1320K	6283.00
20.00	32.0	104.0	20.0	420g	-1400K	11227.00

Diameter Metric	Tolerances	
	Tolerance +	Tolerance -
Over 1.00 ~ up to 6.00	0.000	0.050
Over 6.00 ~ up to 25.00	0.000	0.080

CARBIDE

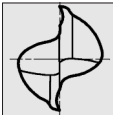

Long Series - 2 Flute



Long Series - Metric

Diameter (mm)	Flute Length	Overall Length	Shank Diameter	Order Code KEN-161	Price/1 TB
3.00	30.0	75.0	3.0	-1930K	1236.00
4.00	30.0	75.0	4.0	-1940K	1545.00
5.00	40.0	100.0	5.0	-1950K	1906.00
6.00	50.0	150.0	6.0	-1960K	2215.00
8.00	50.0	150.0	8.0	-1980K	3219.00
10.00	60.0	150.0	10.0	-1990K	4285.00
12.00	50.0	150.0	15.0	-2000K	5665.00

3 Flute

Offer a combination of advantages achieved with two and four flutes giving profile and peripheral milling capability in addition to slotting and plunging. Chatter is also significantly reduced.
Centre cutting as standard. Manufactured to **ANSI Standards**.

Regular Series - 3 Flute



Regular Series - Metric

Diameter (mm)	Flute Length	Overall Length	Shank Dia.	Weight each	Order Code KEN-161	Price/1 TB
2.00	6.0	38.0	3.0	15g	-4040K	955.00
3.00	10.0	38.0	3.0	15g	-4060K	903.00
4.00	14.0	50.0	4.0	20g	-4080K	1167.00
5.00	16.0	50.0	6.0	30g	-4100K	1486.00
6.00	19.0	50.0	6.0	35g	-4120K	1645.00
8.00	20.0	63.0	8.0	40g	-4160K	2070.00
10.00	22.0	75.0	10.0	100g	-4200K	3183.00
12.00	25.0	75.0	12.0	130g	-4240K	5040.00

Long Series - 3 Flute



Long Series - Metric

Diameter (mm)	Flute Length	Overall Length	Shank Dia.	Weight each	Order Code KEN-161	Price/1 TB
3.00	25.0	75.0	3.0	15g	-4930K	1645.00
4.00	25.0	75.0	4.0	15g	-4940K	1751.00
5.00	25.0	75.0	5.0	30g	-4950K	2228.00
6.00	25.0	75.0	6.0	30g	-4960K	2441.00
8.00	25.0	75.0	8.0	40g	-4980K	3193.00
10.00	38.0	100.0	10.0	100g	-4990K	3811.00
12.00	50.0	100.0	12.0	130g	-4992K	7109.00

CARBIDE

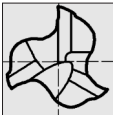

4 Flute Four flute milling cutters have one of the strongest tooth structures available in solid cutters.
Centre cutting as standard. Manufactured to **ANSI Standards**.

Regular Series - 4 Flute



Regular Series - Metric

Diameter (mm)	Flute Length	Overall Length	Shank Dia.	Weight each	Order Code KEN-161	Price/1 TB
2.0	6.3	38.0	3.0	10g	-7040K	1167.00
3.0	12.0	38.0	3.0	10g	-7060K	1019.00
4.0	14.0	50.0	4.0	15g	-7080K	1348.00
5.0	16.0	50.0	6.0	25g	-7100K	1720.00
6.0	19.0	50.0	6.0	25g	-7120K	1676.00
7.0	19.0	63.0	8.0	45g	-7140K	2324.00
8.0	20.0	63.0	8.0	55g	-7160K	2196.00
10.0	22.0	75.0	10.0	90g	-7200K	3131.00
12.0	25.0	75.0	12.0	120g	-7240K	4987.00

Long Series - 4 Flute



Long Series - Metric

Diameter (mm)	Flute Length	Overall Length	Shank Dia.	Weight each	Order Code KEN-161	Price/1 TB
3.00	25.0	75.0	3.0	15g	-7930K	1858.00
4.00	25.0	75.0	4.0	25g	-7940K	1964.00
5.00	25.0	75.0	5.0	30g	-7950K	2070.00
6.00	25.0	75.0	6.0	30g	-7960K	2228.00
10.00	38.0	100.0	10.0	100g	-7990K	5252.00
12.00	50.0	100.0	12.0	130g	-7992K	6896.00

CARBIDE

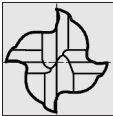



SHANK MILLING CUTTERS - DIE & MOULD

**HSS-E PM Cutters
TiALN Coated**



CUTTING TOOLS

The combination of **HSS-E PM** and **TiALN**

produces a cutter that is ideally suited to dry and semi dry machining of:

- Materials up to 45 HRC.
- Stainless steels
- Aerospace alloys.

HSS-E PM HSS-E PM is a sintered powder metallurgy HSS that combines the toughness associated with HSS-Co and the hardness benefits of carbide.

- Up to 25% higher cutting speed than HSS/HSS-Co. cutters.
- Up to 125% higher feed rates.
- Up to 100% longer cutter life.
- Reduced manufacturing costs.
- Improved productivity.
- Lower coolant usage and disposal costs.

TiALN TiALN is a multi-layer coating capable of operating at higher speed and feed.

- Protects cutting edge under extreme conditions.
- Surface hardness 3000HV.
- Surface coefficient against steel 0.4.
- Thickness of coating 3 - 4µm.
- Maximum working temperature 800°C.
- Re-coating service also available.

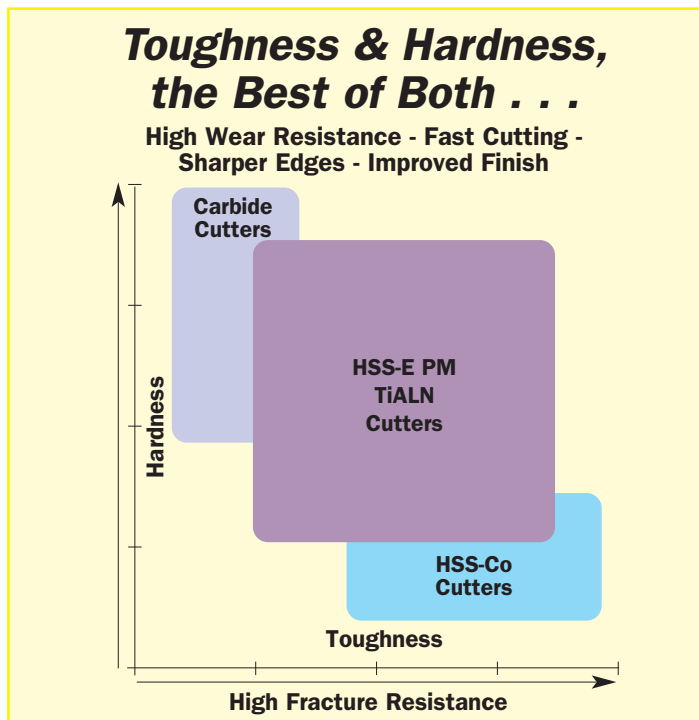

Weldon Shank HSS-E PM TiALN Coated 45° High Helix Milling Cutters

Centre cutting. Weldon shank to **DIN 1835B**. Cutting diameter to **k10**. Shank diameter to **h6**.

HSS-E PM TiALN

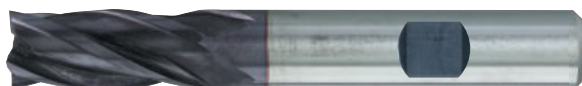
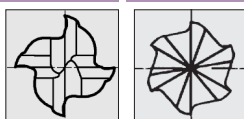

Series 90 Regular Series Dimensions to **DIN 844**

Diameter (mm)	Flute Length	Overall Length	Shank Dia.	No. of Flutes	EHP-4WR PM Coated	
					Order Code SWT-165	Price/1 TB
6.00	13.0	57.0	6.0	4	-9006A	1029.00
8.00	19.0	69.0	10.0	4	-9008A	1545.00
10.00	22.0	72.0	10.0	4	-9010A	1648.00
12.00	26.0	83.0	12.0	4	-9012A	2524.00
16.00	32.0	93.0	16.0	6	-9016A	3605.00
20.00	38.0	104.0	20.0	6	-9020A	5665.00
25.00	45.0	121.0	25.0	6	-9025A⁽¹⁾	9785.00

⁽¹⁾ RFP-6WR PM Coated

Weldon Shank HSS-E PM TiALN Coated High Helix Cutters

Centre cutting. Weldon shank to **DIN 1835B**. Cutting diameter to **k10**. Shank diameter to **h6**.

HSS-E PM TiALN

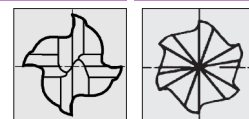

Series 92 Long Series Dimensions to **DIN 844**

Diameter (mm)	Flute Length	Overall Length	Shank Dia.	No. of Flutes	EHP-4WL PM Coated	
					Order Code SWT-165	Price/1 TB
6.00	24.0	68.0	6.0	4	-9206A	1391.00
8.00	38.0	78.0	10.0	4	-9208A	1700.00
10.00	45.0	95.0	10.0	4	-9210A	2059.00
12.00	53.0	110.0	12.0	4	-9212A	3348.00
16.00	45.0	100.0	16.0	6	-9216A	4790.00
20.00	58.0	122.0	20.0	6	-9220A	7983.00
25.00	90.0	166.0	25.0	6	-9225A⁽¹⁾	13622.00

⁽¹⁾ EHP-6WL PM Coated

Weldon Shank HSS-E PM TiALN Coated Fine Pitch Ripper Cutters

Centre cutting. Shank to **DIN 1835B**. Cutting diameter to **js12**. Shank diameter to **h6**.

HSS-E PM TiALN

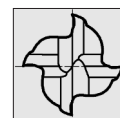

Series 96 Long Series Dimensions to **DIN 844**

Diameter (mm)	Flute Length	Overall Length	Shank Diameter	Number of Flutes	RFP-4WL PM Coated	
					Order Code SWT-165	Price/1 TB
6.00	24.0	68.0	6.0	4	-9606A	2163.00
8.00	38.0	88.0	10.0	4	-9608A	2936.00
10.00	45.0	95.0	10.0	5	-9610A	3296.00
12.00	53.0	110.0	12.0	5	-9612A	4223.00
16.00	63.0	123.0	16.0	5	-9616A	6695.00
20.00	75.0	141.0	20.0	5	-9620A	9269.00
25.00	90.0	166.0	25.0	6	-9625A⁽¹⁾	14935.00

⁽¹⁾ RFP-6WL PM Coated

PRODUCTS ARE ONLY AVAILABLE VIA YOUR DISTRIBUTOR



PEAK POWER The latest addition of the Swiss+Tech range. Manufactured from premium High Speed Steel using the latest in Powdered Metallurgy, these cutters will produce a Powerful Milling performance when cutting difficult materials - even at high speeds.

- Designed to provide strength and rigidity
- Excellent geometry gives optimised cutting and minimises vibration at high speeds
- The range is further enhanced by the Peak Power coating
- Reduced manufacturing costs
- Greater wear resistance and hot-hardness than conventional TiAlN or TiCN coatings
- Suited to dry cutting applications
- Higher oxidation resistance

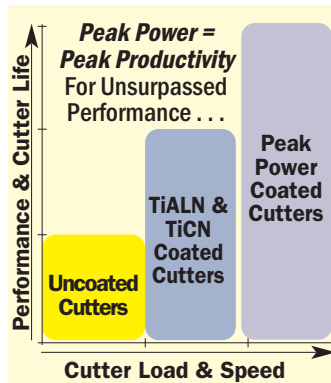

This coating results in the tools withstanding the high thermal loads associated with high speed applications.

HSS-E PM Coated 3 Flute End Mills

HSS-E PM

Centre cutting. Weldon shank to DIN 1835B. Shank diameter to h6. Dimensions to DIN 844.

PEAK POWER



Series 93 Regular

Peak Power Coated						
Diameter (mm)	Flute Length	Overall Length	Shank Diameter	Order Code SWT-165	Price/1 TB	
2.00	4.0	48.0	6.0	-9302A	1029.00	
3.00	5.0	49.0	6.0	-9303A	1339.00	
4.00	7.0	51.0	6.0	-9304A	1648.00	
5.00	8.0	52.0	6.0	-9305A	903.00	
6.00	8.0	52.0	6.0	-9306A	2215.00	
8.00	11.0	61.0	10.0	-9308A	2833.00	
10.00	13.0	63.0	10.0	-9310A	1391.00	
12.00	16.0	73.0	12.0	-9312A	1803.00	
16.00	19.0	79.0	16.0	-9316A	2266.00	
20.00	22.0	88.0	20.0	-9320A	3708.00	

HSS-E PM Coated 4 Flute End Mills

HSS-E PM

Centre cutting. Weldon shank to DIN 1835B. Shank diameter to h6. Dimensions to DIN 844.

PEAK POWER



Series 95 Regular

Peak Power Coated						
Diameter (mm)	Flute Length	Overall Length	Shank Diameter	Order Code SWT-165	Price/1 TB	
3.00	8.0	52.0	6.0	-9503A	1133.00	
4.00	11.0	55.0	6.0	-9504A	1133.00	
5.00	13.0	57.0	6.0	-9505A	1133.00	
6.00	13.0	57.0	6.0	-9506A	1133.00	
8.00	19.0	69.0	6.0	-9508A	1571.00	
10.00	22.0	72.0	10.0	-9510A	1700.00	
12.00	26.0	83.0	12.0	-9512A	2059.00	
14.00	26.0	83.0	12.0	-9514A	3089.00	
16.00	32.0	92.0	16.0	-9516A	3348.00	
20.00	38.0	104.0	20.0	-9520A	4790.00	

HSS-E PM Fine Pitch Ripper Cutters

HSS-E PM

45° high helix, fine pitch, centre cutting. Weldon shank to DIN 1835B. Shank diameter to h6. Dimensions to DIN 844.

PEAK POWER



Series 98 Regular

Peak Power Coated						
Diameter (mm)	Flute Length	Overall Length	Shank Diameter	Order Code SWT-165	Price/1 TB	
5.00	13.0	57.0	6.0	-9805A	2009.00	
6.00	13.0	57.0	6.0	-9806A	2189.00	
8.00	19.0	69.0	10.0	-9808A	2421.00	
10.00	22.0	72.0	10.0	-9810A	2730.00	
12.00	26.0	83.0	12.0	-9812A	4635.00	
16.00	32.0	92.0	16.0	-9816A	5665.00	

HSS-E PM Coated 2 Flute Slot Drills

HSS-E PM

Centre cutting. Weldon shank to DIN 1835B. Shank diameter to h6. Dimensions to DIN 844.

PEAK POWER



Series 91 Regular

Peak Power Coated						
Diameter (mm)	Flute Length	Overall Length	Shank Diameter	Order Code SWT-165	Price/1 TB	
2.00	4.0	47.0	6.0	-9102A	1236.00	
3.00	5.0	49.0	6.0	-9103A	1339.00	
4.00	7.0	51.0	6.0	-9104A	1545.00	
5.00	8.0	52.0	6.0	-9105A	1803.00	
6.00	8.0	52.0	6.0	-9106A	2009.00	
8.00	11.0	61.0	10.0	-9108A	2575.00	
10.00	13.0	63.0	10.0	-9110A	3605.00	
12.00	16.0	73.0	12.0	-9112A	3863.00	

HSS-E PM Coated Fine Pitch Ripper

HSS-E PM

Centre cutting. Weldon shank to DIN 1835B. Cutting diameter to js12. Shank diameter to h6. Dimensions to DIN 844.

PEAK POWER



Series 94 Regular

Peak Power Coated						
Diameter (mm)	Flute Length	Overall Length	Shank Diameter	No. of Flutes	Order Code SWT-165	Price/1 TB
6.00	13.0	57.0	6.0	3	-9406A	2059.00
8.00	19.0	69.0	10.0	3	-9408A	2472.00
10.00	22.0	72.0	10.0	4	-9410A	2524.00
12.00	26.0	83.0	12.0	4	-9412A	2833.00
16.00	32.0	94.0	16.0	4	-9416A	3914.00
20.00	38.0	104.0	20.0	4	-9420A	5459.00
25.00	45.0	121.0	25.0	5	-9425A	7983.00

HSS-E PM Coated 2 Flute Ball Nosed Slot Drills

HSS-E PM

Centre cutting. Weldon shank to DIN 1835B. Shank diameter to h6. Dimensions to DIN 844.

PEAK POWER



Series 97 Regular

Peak Power Coated						
Diameter (mm)	Flute Length	Overall Length	Shank Diameter	Order Code SWT-165	Price/1 TB	
3.00	5.0	49.0	6.0	-9703A	1185.00	
4.00	7.0	51.0	6.0	-9704A	1803.00	
5.00	8.0	52.0	6.0	-9705A	1803.00	
6.00	8.0	52.0	6.0	-9706A	2009.00	
8.00	11.0	61.0	10.0	-9708A	2524.00	
10.00	13.0	63.0	10.0	-9710A	3605.00	
12.00	16.0	73.0	12.0	-9712A	4635.00	

HSS-E PM Coated Coarse Pitch Ripper Cutters

HSS-E PM

Centre cutting. Weldon shank to DIN 1835B. Shank diameter to h6. Dimensions to DIN 844.

PEAK POWER



Series 99 Regular

Peak Power Coated						
Diameter (mm)	Flute Length	Overall Length	Shank Diameter	No. of Flutes	Order Code SWT-165	Price/1 TB
8.00	19.0	69.0	10.0	3	-9908A	2189.00
10.00	22.0	72.0	10.0	4	-9910A	2575.00
12.00	26.0	83.0	12.0	4	-9912A	3039.00
16.00	32.0	92.0	16.0	4	-9916A	6438.00
20.00	38.0	104.0	20.0	4	-9920A	4463.00



HSS-E PM 2 Flute Slot Drill Peak Power Set

Weldon Shank - 7 Piece Set
Centre cutting.
To **Manufacturers Standards**.
Weldon shank to **DIN 1835B**.
Shank diameter to **h6**.
Dimensions to **DIN 844**.

Contents: 3, 4, 5, 6, 8, 10 and 12mm.

HSS-E PM

PEAK POWER

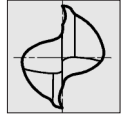

**7
PIECES**



Series 91

Number of Pieces	Contents	Order Code SWT-165	Price/1 TB
7	3, 4, 5, 6, 8, 10, & 12mm	-9150A	8601.00

HSS-E PM 2 Flute Ball Nose Slot Drill Peak Power Set

Weldon Shank - 7 Piece Set
Centre cutting.
To **Manufacturers Standards**.
Weldon shank to **DIN 1835B**.
Shank diameter to **h6**.
Dimensions to **DIN 844**.

Contents: 3, 4, 5, 6, 8, 10 and 12mm.

HSS-E PM

PEAK POWER

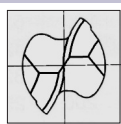

**7
PIECES**



Series 97

Number of Pieces	Contents	Order Code SWT-165	Price/1 TB
7	3, 4, 5, 6, 8, 10 & 12mm	-9750A	9178.00

HSS-E PM High Helix Fine Pitch Ripper Peak Power Set

Weldon Shank - 6 Piece Set
Centre cutting.
To **Manufacturers Standards**.
Weldon shank to **DIN 1835B**.
Shank diameter to **h6**.
Dimensions to **DIN 844**.

Contents: 5, 6, 8, 10, 12 and 16mm.

HSS-E PM

PEAK POWER

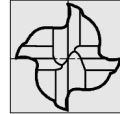

**5
PIECES**



Series 98

Number of Pieces	Contents	Order Code SWT-165	Price/1 TB
6	5, 6, 8, 10, 12 and 16mm	-9850A	15991.00

HSS-E PM Coarse Pitch Ripper Peak Power Set

Weldon Shank - 5 Piece Set
Centre cutting.
To **Manufacturers Standards**.
Weldon shank to **DIN 1835B**.
Shank diameter to **h6**.
Dimensions to **DIN 844**.

Contents: 8, 10, 12, 16 and 20mm.

HSS-E PM

PEAK POWER

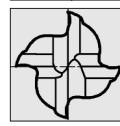
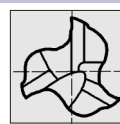

**5
PIECES**



Series 99

Number of Pieces	Contents	Order Code SWT-165	Price/1 TB
5	8, 10, 12, 16 & 20mm	-9950A	12875.00

SWISS+TECH



**Carbide Cutters
Q-Coat Coated**

Q-Coat has been specifically developed to give carbide cutters the 'edge' when faced with severe machining conditions.

- Materials up to 66HRC.
- Dry Cutting.
- Die and Mould Machining
- Improved Productivity.
- Reduced coolant usage and disposal.
- Up to 100% longer cutter life.
- Reduced manufacturing costs.

A multi-layer coating capable of operating at higher speed and feed.

- Excellent oxidation resistance.
- High speed machining.
- Surface hardness 3300HV.
- Surface coefficient against steel 0.25.
- Thickness of coating 3 - 5µm.
- Maximum working temperature 850°C.
- Re-coating service also available.

Carbide Plain Shank Slot Drills 2 Flute

Centre cutting. To **Manufacturers Standards**. Cutting diameter to **h10**. Shank diameter to **h6**. **SDQ-2PS Carbide Q-Coat.**

CARBIDE Q-Coat

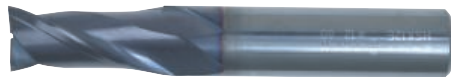
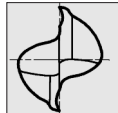

Series 60 Short Series Dimensions to DIN 844

SDQ-2PS Carbide Q-Coat					
Diameter (mm)	Flute Length	Overall Length	Shank Diameter	Order Code SWT-165	Price/1 TB
1.00	2.5	45.0	4.0	-6001A	1751.00
2.00	6.0	45.0	4.0	-6002A	1803.00
3.00	8.0	45.0	6.0	-6003A	2369.00
4.00	11.0	45.0	6.0	-6004A	2369.00
5.00	13.0	50.0	6.0	-6005A	2369.00
6.00	13.0	50.0	6.0	-6006A	2369.00
7.00	16.0	60.0	8.0	-6007A	4496.00
8.00	19.0	60.0	8.0	-6008A	2833.00
9.00	19.0	70.0	8.0	-6009A	4069.00
10.00	22.0	70.0	10.0	-6010A	4378.00
12.00	26.0	75.0	12.0	-6012A	5665.00
16.00	32.0	100.0	16.0	-6016A	9785.00

Carbide Plain Shank Slot Drills 2 Flute

Centre cutting. To **Manufacturers Standards**. Cutting diameter to **h10**. Shank diameter to **h6**. **SDQ-2PS Carbide Q-Coat.**

CARBIDE Q-Coat

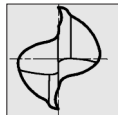

Series 62 Long Series Dimensions to DIN 844

SDQ-2PL Carbide Q-Coat					
Diameter (mm)	Flute Length	Overall Length	Shank Diameter	Order Code SWT-165	Price/1 TB
3.00	12.0	50.0	6.0	-6203A	2936.00
4.00	15.0	50.0	6.0	-6204A	3039.00
6.00	20.0	60.0	6.0	-6206A	3767.00
8.00	25.0	70.0	8.0	-6208A	4790.00
10.00	30.0	90.0	10.0	-6210A	6747.00
12.00	30.0	90.0	12.0	-6212A	8223.00
16.00	50.0	110.0	16.0	-6216A	13184.00
20.00	55.0	110.0	20.0	-6220A	22145.00

A Step Beyond Carbide . . .

For Extreme Conditions - High Cutting Speeds

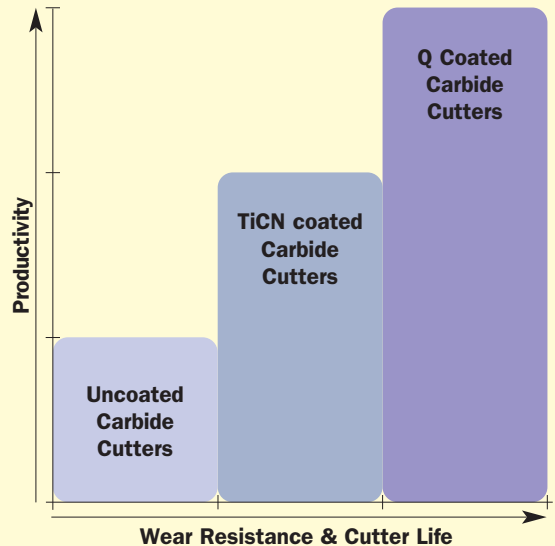

Carbide Plain Shank End Mills 4 Flute

Centre cutting. To **Manufacturers Standards**. Cutting diameter to **h10**. Shank diameter to **h6**. **EMQ-4PS/L Carbide Q-Coat.**

CARBIDE Q-Coat



Series 66 Short Series Dimensions to DIN 844

EMQ-4PS Carbide Q-Coat					
Diameter (mm)	Flute Length	Overall Length	Shank Diameter	Order Code SWT-165	Price/1 TB
2.00	6.0	40.0	4.0	-6602A	1803.00
3.00	8.0	45.0	6.0	-6603A	2266.00
4.00	11.0	45.0	6.0	-6604A	2266.00
5.00	13.0	50.0	6.0	-6605A	2266.00
6.00	13.0	50.0	6.0	-6606A	2266.00
7.00	16.0	60.0	8.0	-6607A	2833.00
8.00	19.0	60.0	8.0	-6608A	2833.00
9.00	19.0	70.0	10.0	-6609A	4069.00
10.00	22.0	70.0	10.0	-6610A	4378.00
11.00	22.0	75.0	12.0	-6611A	5665.00
12.00	26.0	75.0	12.0	-6612A	6179.00
14.00	26.0	85.0	14.0	-6614A	9538.00
16.00	32.0	100.0	16.0	-6616A	9909.00
18.00	32.0	100.0	18.0	-6618A	13905.00
20.00	38.0	105.0	20.0	-6620A	15965.00

Carbide Plain Shank End Mills 4 Flute

Centre cutting. To **Manufacturers Standards**. Cutting diameter to **h10**. Shank diameter to **h6**. **EMQ-4PS/L Carbide Q-Coat.**

CARBIDE Q-Coat



Series 68 Long Series Dimensions to DIN 844

EMQ-4PL Carbide Q-Coat					
Diameter (mm)	Flute Length	Overall Length	Shank Diameter	Order Code SWT-165	Price/1 TB
3.00	12.0	50.0	6.0	-6803A	2918.00
4.00	15.0	50.0	6.0	-6804A	2918.00
5.00	20.0	60.0	6.0	-6805A	3183.00
6.00	20.0	60.0	6.0	-6806A	3449.00
8.00	25.0	70.0	8.0	-6808A	4510.00
10.00	30.0	90.0	10.0	-6810A	6313.00
12.00	30.0	90.0	12.0	-6812A	7480.00
16.00	50.0	110.0	16.0	-6816A	12875.00

SWISS+TECH

Carbide Plain Shank Slot Drills 2 Flute Ball Nose

Centre cutting.
To **Manufacturers Standards**.
Cutting diameter to **e8**.
Shank diameter to **h6**.
Carbide Q-Coat.



Series 73 Long Reach

Dia. (mm)	Shank Dia	Length of Cut	Length Below Shank	Overall Length	Neck Dia.	Carbide Q-Coat	
						Order Code SWT-165	Price/1 TB
0.60	4.0	0.9	6.0	35.0	0.55	-7302A	3605.00
1.50	4.0	2.3	20.0	55.0	1.39	-7310A	2918.00
2.00	4.0	3.0	16.0	50.0	1.91	-7318A	2918.00
2.00	4.0	3.0	20.0	55.0	1.89	-7320A	3605.00

Carbide Plain Shank Slot Drills Ball Nosed 2 Flute

Centre cutting.
To **Manufacturers Standards**.
Cutting diameter to **e8**.
Shank diameter to **h6**.
SBQ-2PR Carbide Q-Coat.



Series 78 Regular Length

Diameter (mm)	Flute Length	Overall Length	Shank Diameter	SBQ-2PR Carbide Q-Coat	
				Order Code SWT-165	Price/1 TB
2.00	5.0	50.0	6.0	-7802A	2009.00
2.50	6.0	60.0	6.0	-7802L	2215.00
3.00	8.0	60.0	6.0	-7803A	2318.00
4.00	8.0	70.0	6.0	-7804A	2318.00
5.00	10.0	80.0	6.0	-7805A	2369.00
6.00	12.0	90.0	6.0	-7806A	2678.00
8.00	14.0	100.0	8.0	-7808A	4775.00
10.00	18.0	100.0	10.0	-7810A	6896.00
12.00	22.0	110.0	12.0	-7812A	9018.00

Carbide Plain Shank Slot Drills 2 Flute

Centre cutting.
To **Manufacturers Standards**.
Cutting diameter to **h10**.
Shank diameter to **h6**.
Carbide Q-Coat.

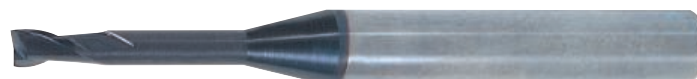
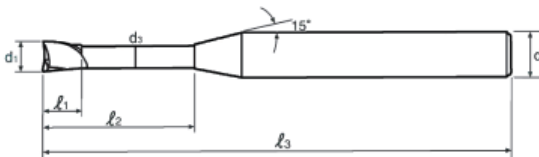

Series 74 Long Reach

Dia. (mm) (d1)	Shank Dia. (d2)	Length of Cut (l1)	Length Below Shk (l2)	Overall Length (l3)	Neck Dia. (d3)	Carbide Q-Coat	
						Order Code SWT-165	Price/1 TB
0.50	4.0	0.7	6.0	45.0	0.45	-7402A	2369.00
0.60	4.0	0.9	4.0	45.0	0.55	-7404A	2369.00
0.80	4.0	1.2	4.0	45.0	0.75	-7408A	2369.00
1.00	4.0	1.5	8.0	45.0	0.95	-7412A	2369.00
1.00	4.0	1.5	10.0	45.0	0.95	-7414A	2369.00
1.20	4.0	1.8	12.0	45.0	1.13	-7416A	2369.00
1.50	4.0	2.3	16.0	50.0	1.41	-7418A	2369.00
2.00	4.0	3.0	14.0	50.0	1.93	-7420A	2369.00
2.00	4.0	3.0	20.0	55.0	1.89	-7422A	2369.00



CARBIDE

Q-Coat

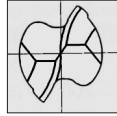

Carbide Plain Shank End Mills Ball Nosed 4 Flute

Centre cutting.
To **Manufacturers Standards**.
Cutting diameter to **e8**. Shank diameter to **h6**.
EBQ-4PR Carbide Q-Coat.

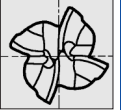

Series 80 - Regular Length Dimensions to DIN 844

Diameter (mm)	Flute Length	Overall Length	Shank Diameter	EBQ-4PR Q-Coat	
				Order Code SWT-165	Price/1 TB
4.00	8.0	70.0	6.0	-8004A	3289.00
5.00	10.0	80.0	6.0	-8005A	3714.00
6.00	12.0	90.0	6.0	-8006A	3608.00
8.00	14.0	100.0	8.0	-8008A	4350.00
10.00	18.0	100.0	10.0	-8010A	7365.00
12.00	22.0	110.0	12.0	-8012A	8239.00

Carbide Plain Shank Corner Radius End Mills 4 Flute

Centre cutting. To **Manufacturers Standards**.
Cutting diameter to **e8**. Shank diameter to **h6**.
ECQ-4PR Carbide Q-Coat.



Series 86 - Regular Length

Diameter x Corner Radius (mm)	Flute Length	Overall Length	Shank Diameter	ECQ-4PR Q-Coat	
				Order Code SWT-165	Price/1 TB
6.00 x 0.5	20.0	60.0	6.0	-8604K	3193.00
6.00 x 1.0	20.0	60.0	6.0	-8605K	3193.00
8.00 x 0.5	25.0	70.0	8.0	-8606K	4119.00
8.00 x 1.0	25.0	70.0	8.0	-8607K	4119.00
8.00 x 1.5	25.0	70.0	8.0	-8608K	4635.00
8.00 x 2.0	25.0	70.0	8.0	-8609K	4635.00
10.00 x 0.5	30.0	90.0	10.0	-8610K	6179.00
10.00 x 1.0	30.0	90.0	10.0	-8611K	6179.00
10.00 x 1.5	30.0	90.0	10.0	-8612K	6695.00
10.00 x 2.0	30.0	90.0	10.0	-8613K	6695.00
12.00 x 0.5	30.0	90.0	12.0	-8614K	8239.00
12.00 x 1.0	30.0	90.0	12.0	-8615K	8239.00
12.00 x 1.5	30.0	90.0	12.0	-8616K	9269.00

Carbide Plain Shank End Mills High Helix

Centre cutting. To **Manufacturers Standards**.
Cutting diameter to **e8**. Shank diameter to **h6**.
EHQ-6*PR Carbide Q-Coat.

*Number varies according to the number of flutes.

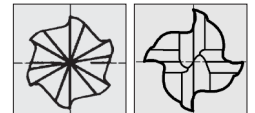

Series 72 Regular Length

Diameter (mm)	Flute Length	Overall Length	Shank Diameter	No. of Flutes	EHQ-6PR Carbide Q-Coat	
					Order Code SWT-165	Price/1 TB
3.00	8.0	57.0	6.0	4.0	-7203A	2730.00
4.00	11.0	57.0	6.0	4.0	-7204A	2730.00
6.00	13.0	57.0	6.0	6.0	-7206A	2833.00
8.00	19.0	63.0	8.0	6.0	-7208A	3348.00
10.00	22.0	72.0	10.0	6.0	-7210A	4893.00
12.00	26.0	83.0	12.0	6.0	-7212A	6438.00
16.00	32.0	92.0	16.0	6.0	-7216A	11279.00
20.00	38.0	104.0	20.0	8.0	-7220A	16326.00

Carbide Plain Shank Ripper Fine Pitch

Centre cutting. To **Manufacturers Standards**.
Cutting diameter to **e8**. Shank diameter to **h6**.
RFQ-3*PR Carbide Q-Coat.

*Number varies according to the number of flutes.

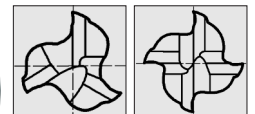

Series 82 - Regular Length Dimensions to DIN 844

Diameter (mm)	Flute Length	Overall Length	Shank Diameter	Number of Flutes	RFQ-3PR Q-Coat	
					Order Code SWT-165	Price/1 TB
6.00	16.0	57.0	6.0	3.0	-8206A	3089.00
8.00	16.0	63.0	8.0	3.0	-8208A	3605.00
10.00	22.0	72.0	10.0	4.0	-8210A	5149.00
12.00	26.0	83.0	12.0	4.0	-8212A	6489.00
16.00	32.0	92.0	16.0	4.0	-8216A	10815.00
20.00	38.0	104.0	20.0	4.0	-8220A	16995.00

GROUP 062 THROWAWAY MILLING CUTTERS



HSS-Co 5% KC3 3* Flute Throwaway Milling Cutters

Suitable for slot drilling and end milling. Cutters are held in adaptors/chucks by the action of a set screw which locates on the shank flat giving quick and easy cutter change.

*Except: 1mm cutters, 2mm and 1/16" ball nose cutters all of which have two flutes.

Diameter Metric	Tolerances		Diameter Inch	Tolerance	
	Tolerance +	-		Tolerance +	-
Over 1.00 ~ up to 3.00	0.013	0.033	Over 1/16" ~ up to 1/4"	0.0005	0.0013
Over 3.00 ~ up to 6.00	0.020	0.020			

Short Series

HSS-Co 5%



Shank Diameter: 1.00 ~ 6.00 = 6.00mm, 7.00 ~ 10.00 = 10.00mm

Diameter (mm)	Flute Length	Overall Length	Chuck Clearance	Weight each	Order Code KEN-062	Price/1 TB
1.00	2.0	24.5	8.5	10g	-0010K	464.00
1.50	2.5	24.5	8.5	10g	-0020K	464.00
2.00	3.0	25.5	9.5	10g	-0040K	464.00
2.50	4.0	26.0	10.5	10g	-0060K	464.00
3.00	4.5	28.0	11.0	10g	-0080K	464.00
3.50	5.5	30.0	12.0	10g	-0100K	464.00
4.00	6.5	32.5	12.5	10g	-0120K	464.00
5.00	7.5	36.0	13.5	10g	-0160K	464.00
5.50	7.5	36.0	13.5	10g	-0190K	514.00
6.00	9.5	36.0	15.0	10g	-0200K	464.00
8.00	11.0	47.5	19.7	30g	-0240K	650.00
10.00	13.0	51.5	20.5	35g	-0280K	650.00

Long Series

HSS-Co 5%



Diameter (mm)	Flute Length	Overall Length	Chuck Clearance	Weight each	Order Code KEN-062	Price/1 TB
1.50	4.0	28.0	10.0	10g	-1020K	514.00
2.00	4.5	29.0	11.0	10g	-1040K	514.00
2.50	6.5	32.0	12.5	10g	-1060K	514.00
3.00	7.5	34.0	14.5	10g	-1080K	514.00
3.50	8.5	36.5	15.0	10g	-1100K	514.00
4.00	9.5	39.0	16.0	10g	-1120K	514.00
4.50	11.0	42.0	17.5	10g	-1140K	514.00
5.00	12.5	44.5	17.5	10g	-1160K	514.00
5.50	14.5	46.0	19.0	10g	-1180K	514.00
6.00	16.0	44.5	20.5	10g	-1200K	514.00
8.00	19.0	55.5	27.9	30g	-1240K	564.00
10.00	22.5	61.5	31.6	40g	-1280K	725.00

Long Series



Diameter (mm)	Flute Length	Overall Length	Chuck Clearance	Weight each	Order Code KEN-062	Price/1 TB
1.50	4.0	28.0	10.0	10g	-6020K	1545.00
2.00	4.5	29.0	11.0	10g	-6040K	728.00
2.50	6.5	32.0	12.5	10g	-6060K	1803.00
3.00	7.5	34.0	14.5	10g	-6080K	728.00
4.00	9.5	39.0	16.0	10g	-6120K	728.00
4.50	11.0	42.0	17.5	10g	-6140K	728.00
5.00	12.5	44.5	17.5	10g	-6160K	728.00
5.50	14.5	46.0	19.0	10g	-6180K	728.00
6.00	16.0	44.5	20.5	10g	-6200K	728.00

HSS-Co 5% TiN KC3 Coated Throwaway Milling Cutters

TiN-Coated to allow elevated cutting speeds and help to extend tool life.

HSS-Co 5% TiN

Short Series



Diameter (mm)	Flute Length	Overall Length	Chuck Clearance	Weight each	Order Code KEN-062	Price/1 TB
1.00	2.0	24.5	8.5	10g	-3010K	427.00
1.50	2.5	24.5	8.5	10g	-3020K	632.00
2.00	3.0	25.5	9.5	10g	-3040K	575.00
2.50	4.0	26.0	10.5	10g	-3060K	575.00
3.00	4.5	28.0	11.0	10g	-3080K	575.00
3.50	5.5	30.0	12.0	10g	-3100K	575.00
4.00	6.5	32.5	12.5	10g	-3120K	575.00
5.00	7.5	36.0	13.5	10g	-3160K	575.00
6.00	9.5	36.0	15.0	10g	-3200K	575.00

Long Series

HSS-Co 5% TiN



Diameter (mm)	Flute Length	Overall Length	Chuck Clearance	Weight each	Order Code KEN-062	Price/1 TB
1.50	4.0	28.0	10.0	10g	-4020K	672.00
2.00	4.5	29.0	11.0	10g	-4040K	607.00
2.50	6.5	32.0	12.5	10g	-4060K	607.00
3.00	7.5	34.0	14.5	10g	-4080K	607.00
4.00	9.5	39.0	16.0	10g	-4120K	607.00
4.50	11.0	42.0	17.5	10g	-4140K	607.00
5.00	12.5	44.5	17.5	10g	-4160K	607.00
5.50	14.5	46.0	19.0	10g	-4180K	607.00
6.00	16.0	44.5	20.5	10g	-4200K	607.00

HSS-Co 5% TiCN-Coated Throwaway Milling Cutters

With a micro hardness of

3000HV and a maximum working temperature of 400°C, giving them a better resistance to abrasive wear than TiN coated cutters.

HSS-Co 5% TiCN



Short Series

Diameter (mm)	Flute Length	Overall Length	Chuck Clearance	Weight each	Order Code KEN-062	Price/1 TB
1.00	2.0	24.5	8.5	10g	-5010K	1379.00
1.50	2.5	24.5	8.5	10g	-5020K	751.00
2.00	3.0	25.5	9.5	10g	-5040K	698.00
2.50	4.0	26.0	10.5	10g	-5060K	1288.00
3.00	4.5	28.0	11.0	10g	-5080K	698.00
3.50	5.5	30.0	12.0	10g	-5100K	1288.00
4.00	6.5	32.5	12.5	10g	-5120K	698.00
5.00	7.5	36.0	13.5	10g	-5160K	698.00
6.00	9.5	36.0	15.0	10g	-5200K	698.00

HSS-Co 5% TiCN

**Straight & Taper
Shank Drills**



**Centre
Drills**



**Countersinks &
Counterbores**

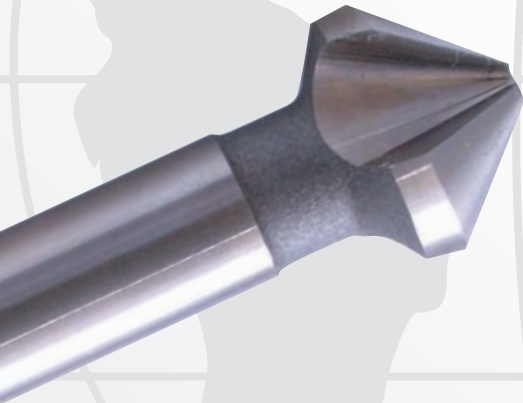

**Shank & Bore
Milling Cutters**



**Hand & Machine
Reamers**

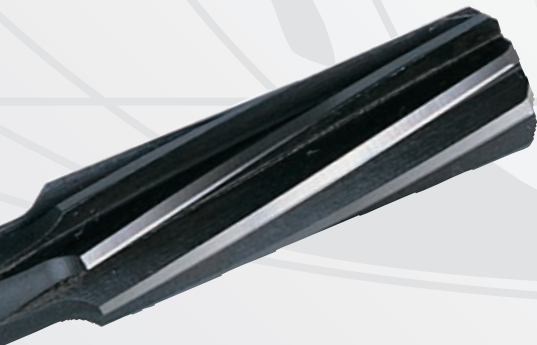

**Hand &
Machine Taps**



Full Range of Sizes and Sets - Massive Stocks Available!
mm, inch, DIN, ISO, UN, BS, and ANSI Standards

GROUP 065 REAMERS - CHUCKING



Straight Shank Machine Reamers

Left hand spiral flute, right hand cutting.
Manufactured to **BS 328-4**.

Diameter Metric	Tolerance	
	High +	Low -
up to 3.00	0.008	0.004
Over 3.00 ~ up to 6.00	0.010	0.005
Over 6.00 ~ up to 10.00	0.012	0.006
Over 10.00 ~ up to 18.00	0.015	0.008



HSS

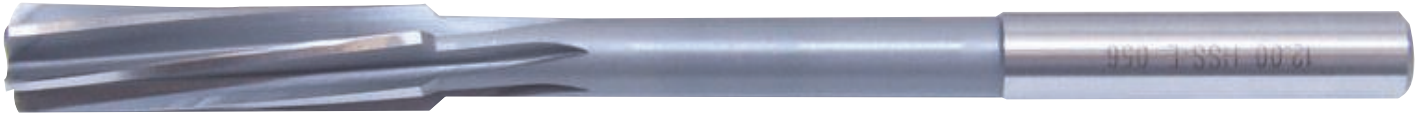

CUTTING TOOLS

Diameter (mm)	Flute Length	Overall Length	Weight each	Order Code SHR-065	Price/1 TB
1.50	21.0	44.0	3g	-2219X	1623.00
2.00	25.0	50.0	3g	-2220A	1406.00
2.50	29.0	58.0	3g	-2221B	1461.00
3.00	31.0	62.0	3g	-2222C	1137.00
3.50	33.0	66.0	4g	-2223D	1298.00
4.00	38.0	76.0	5g	-2224E	1137.00
4.50	41.0	81.0	6g	-2225F	1298.00
5.00	44.0	87.0	8g	-2226G	1137.00
5.50	47.0	93.0	12g	-2227H	1461.00
6.00	47.0	93.0	18g	-2228J	1298.00

Diameter (mm)	Flute Length	Overall Length	Weight each	Order Code SHR-065	Price/1 TB
7.00	54.0	107.0	17g	-2229K	1406.00
8.00	58.0	115.0	20g	-2230L	1569.00
9.00	62.0	124.0	31g	-2231M	1785.00
10.00	66.0	133.0	55g	-2232N	1947.00
11.00	71.0	142.0	69g	-2232R	2163.00
12.00	76.0	152.0	87g	-2233P	2488.00
13.00	78.0	152.0	97g	-2234Q	2812.00
14.00	81.0	163.0	184g	-2235R	3300.00
16.00	87.0	175.0	235g	-2236S	4110.00

Cobalt Straight Shank Chucking Reamers

Manufactured to **DIN 212**.

Diameter Metric	Tolerances (to H7)	
	Tolerance +	Tolerance -
up to 5.50	0.004	0.000
Over 5.50	0.005	0.000

HSS-E



Diameter (mm)	Flute Length	Overall Length	Weight each	Order Code SHR-065	Price/1 TB
2.00	11.0	49.0	3g	-2655K	1785.00
2.50	14.0	57.0	4g	-2657M	1607.00
3.00	15.0	61.0	5g	-2659P	1428.00
3.50	18.0	70.0	8g	-2661R	1428.00
4.00	19.0	75.0	9g	-2662S	1250.00
4.50	21.0	80.0	12g	-2663T	1500.00
5.00	23.0	86.0	14g	-2664V	1509.00
5.50	26.0	93.0	21g	-2665G	1526.00
6.00	26.0	93.0	25g	-2665W	1548.00
7.00	31.0	109.0	31g	-2666X	1548.00
8.00	33.0	117.0	41g	-2667Y	1726.00

Diameter (mm)	Flute Length	Overall Length	Weight each	Order Code SHR-065	Price/1 TB
9.00	36.0	125.0	56g	-2668Z	1785.00
10.00	38.0	133.0	73g	-2669A	1845.00
11.00	41.0	142.0	84g	-2670B	2380.00
12.00	44.0	151.0	90g	-2671C	2380.00
13.00	44.0	151.0	96g	-2672D	2499.00
14.00	47.0	160.0	101g	-2673E	2975.00
15.00	50.0	162.0	111g	-2674F	3213.00
16.00	52.0	170.0	117g	-2675G	3153.00
18.00	56.0	182.0	227g	-2677J	3807.00
20.00	60.0	195.0	450g	-2679L	4165.00

Straight Shank Parallel Hand Reamers

Used to produce a close tolerance surface finish by hand in almost any environment i.e. on site or in a workshop.
Manufactured to **BS 328-4 and DIN 206B**.

Diameter Metric	Tolerance	
	+	-
up to 3.00	0.008	0.007
Over 3.00 ~ up to 6.00	0.010	0.005
Over 6.00 ~ up to 10.00	0.012	0.006
Over 10.00 ~ up to 18.00	0.015	0.008
Over 18.00 ~ up to 30.00	0.017	0.009
Over 30.00 ~ up to 50.00	0.021	0.012

HSS



Diameter (mm)	Flute Length	Overall Length	Weight each	Order Code SHR-065	Price/1 TB
1.50	20.0	41.0	2g	-2100A	2326.00
2.00	25.0	50.0	3g	-2103D	1358.00
2.50	29.0	58.0	4g	-2105F	1353.00
3.00	31.0	62.0	5g	-2107H	1055.00
3.50	35.0	71.0	6g	-2109K	1007.00
4.00	38.0	76.0	7g	-2110L	779.00
4.50	41.0	81.0	8g	-2111M	1120.00
5.00	44.0	87.0	10g	-2112N	822.00
5.50	47.0	93.0	13g	-2113P	1245.00
6.00	47.0	93.0	19g	-2114Q	866.00
6.50	50.0	100.0	23g	-2115R	1245.00
7.00	54.0	107.0	26g	-2116S	990.00
7.50	54.0	107.0	30g	-2117T	1298.00
8.00	58.0	115.0	38g	-2118V	990.00
8.50	58.0	115.0	43g	-2119W	1298.00
9.00	62.0	124.0	56g	-2120X	1406.00
9.50	62.0	124.0	59g	-2121Y	1651.00
10.00	66.0	133.0	69g	-2122Z	1163.00
10.50	66.0	133.0	78g	-2124A	1759.00

Diameter (mm)	Flute Length	Overall Length	Weight each	Order Code SHR-065	Price/1 TB
11.00	71.0	142.0	91g	-2125B	1742.00
11.50	71.0	142.0	100g	-2126C	1759.00
12.00	76.0	152.0	114g	-2127D	1310.00
12.50	76.0	152.0	121g	-2128E	1920.00
13.00	76.0	152.0	133g	-2129F	1634.00
13.50	81.0	163.0	163g	-2130G	2272.00
14.00	81.0	163.0	163g	-2131H	2326.00
14.50	90.0	162.0	190g	-2132J	2326.00
15.00	81.0	163.0	187g	-2133K	2380.00
16.00	87.0	175.0	237g	-2134L	1796.00
17.00	87.0	175.0	269g	-2135M	2677.00
18.00	93.0	188.0	319g	-2136N	2677.00
19.00	93.0	188.0	336g	-2137P	2775.00
20.00	100.0	201.0	348g	-2138Q	2624.00
22.00	107.0	215.0	500g	-2140S	4223.00
24.00	115.0	231.0	729g	-2142V	4922.00
25.00	115.0	231.0	785g	-2143W	5138.00
30.00	124.0	247.0	1200g	-2148B	6706.00
40.00	152.0	305.0	2500g	-2158M	12503.00



HSS



Taper Shank Machine Reamers

Used to produce a close tolerance surface finish by enlarging pre-drilled holes to a finished size. 45° bevelled lead.
Manufactured to **BS 328-4**.

Tolerances (to H7)			
Diameter Metric	Tolerance		
	+	-	
up to 3.00	0.008	0.004	
Over 3.00 ~ up to 6.00	0.010	0.005	
Over 6.00 ~ up to 10.00	0.012	0.006	
Over 10.00 ~ up to 18.00	0.015	0.008	
Over 18.00 ~ up to 30.00	0.017	0.009	
Over 30.00 ~ up to 50.00	0.021	0.012	
Over 50.00 ~ up to 80.00	0.025	0.014	
Over 80.00 ~ up to 120.00	0.029	0.016	



Diameter (mm)	Flute Length	Overall Length	Morse Taper	Weight each	Order Code SHR-065	Price/1 TB
3.00	33.0	112.0	1	52g	-2350A	4326.00
3.50	35.0	115.0	1	52g	-2351B	4326.00
4.00	38.0	117.0	1	52g	-2352C	3840.00
4.50	41.0	120.0	1	55g	-2353D	3840.00
5.00	44.0	124.0	1	56g	-2354E	3516.00
5.50	47.0	127.0	1	56g	-2355F	3516.00
6.00	47.0	127.0	1	58g	-2356G	3516.00
6.50	50.0	130.0	1	59g	-2357H	3678.00
7.00	54.0	134.0	1	64g	-2358J	3678.00
7.50	54.0	134.0	1	66g	-2359K	3678.00
8.00	58.0	138.0	1	67g	-2360L	3678.00
8.50	58.0	138.0	1	70g	-2361M	3840.00
9.00	62.0	142.0	1	72g	-2362N	3840.00
9.50	62.0	142.0	1	76g	-2363P	3840.00
10.00	66.0	144.0	1	79g	-2364Q	3840.00
10.50	66.0	144.0	1	81g	-2365R	4110.00
11.00	71.0	151.0	1	88g	-2366S	4110.00
11.50	71.0	151.0	1	96g	-2367T	4110.00
12.00	76.0	156.0	1	108g	-2368V	4651.00
12.50	76.0	156.0	1	111g	-2369W	4651.00
13.00	76.0	156.0	1	122g	-2370X	4651.00
13.50	81.0	161.0	1	130g	-2371Y	4651.00
14.00	81.0	163.0	1	126g	-2372Z	5138.00
14.50	81.0	181.0	2	200g	-2374A	5138.00
15.00	81.0	181.0	2	230g	-2375B	5138.00
15.50	87.0	187.0	2	245g	-2376C	3244.00

Diameter (mm)	Flute Length	Overall Length	Morse Taper	Weight each	Order Code SHR-065	Price/1 TB
16.00	87.0	187.0	2	262g	-2377D	5300.00
16.50	87.0	187.0	2	270g	-2378E	5300.00
17.00	87.0	187.0	2	273g	-2379F	6165.00
17.50	93.0	193.0	2	292g	-2379R	6165.00
18.00	93.0	193.0	2	305g	-2380G	7409.00
18.50	93.0	193.0	2	317g	-2380S	7409.00
19.00	93.0	193.0	2	323g	-2381H	7409.00
19.50	100.0	200.0	2	324g	-2381T	7409.00
20.00	100.0	200.0	2	350g	-2382J	7409.00
21.00	100.0	200.0	2	365g	-2383K	7512.00
22.00	107.0	207.0	2	419g	-2384L	7842.00
23.00	107.0	207.0	2	467g	-2385M	7842.00
24.00	115.0	242.0	3	686g	-2386N	7842.00
25.00	115.0	242.0	3	740g	-2387P	7571.00
26.00	115.0	242.0	3	747g	-2388Q	8112.00
27.00	124.0	251.0	3	901g	-2389R	8383.00
28.00	124.0	251.0	3	884g	-2390S	8383.00
30.00	124.0	251.0	3	990g	-2392V	8491.00
32.00	133.0	293.0	4	1510g	-2394X	9572.00
33.00	133.0	293.0	4	1615g	-2395Y	10491.00
34.00	142.0	302.0	4	1726g	-2396Z	11519.00
35.00	142.0	302.0	4	1751g	-2398A	11519.00
38.00	152.0	312.0	4	2039g	-2401D	13844.00
40.00	152.0	312.0	4	2250g	-2403F	15682.00
45.00	163.0	323.0	4	2900g	-2408L	21090.00
50.00	174.0	334.0	4	3630g	-2413R	22820.00

Taper Shank Extra Length Machine Reamers

Used to produce a close tolerance surface finish in drilled holes to allow the fitting of hardened and ground taper pins in the building of jigs, fixtures and dies.
Manufactured to **BS 328-4**.

HSS



Diameter (mm)	Flute Length	Overall Length	Morse Taper	Weight each	Order Code SHR-064	Price/1 TB
6.00	124.0	203.0	1	80g	-2500A	4002.00
8.00	124.0	203.0	1	103g	-2502C	4002.00
10.00	124.0	203.0	1	114g	-2504E	6381.00
10.00	175.0	254.0	1	129g	-2505F	7787.00
12.00	124.0	203.0	1	132g	-2507H	7138.00

Diameter (mm)	Flute Length	Overall Length	Morse Taper	Weight each	Order Code SHR-064	Price/1 TB
12.00	175.0	254.0	1	188g	-2508J	8923.00
12.00	225.0	305.0	1	228g	-2509K	9356.00
16.00	154.0	254.0	2	361g	-2510L	8112.00
16.00	205.0	305.0	2	411g	-2511M	8923.00

Straight Shank Hand Taper Pin Reamers

Used to produce a close tolerance surface finish in taper holes to allow the fitting of hardened and ground taper pins in the building of jigs, fixtures and dies.
Manufactured to **BS 328-4 and DIN 9A**.

HSS

Tolerances		
Diameter Metric	Tolerance	
	+	-
Over 1.50 ~ up to 5.00	0.075	0.000
Over 5.00 ~ up to 20.00	0.125	0.000



Diameter (mm)	Dia. Range		Flute Length	Overall Length	Weight each	Order Code SHR-065	Price/1 TB
	min	max					
1.50	1.4	2.40	37	57	4g	-2800A	2261.00
2.00	1.9	2.86	48	68	4g	-2801B	1434.00
2.50	2.4	3.36	48	68	5g	-2802C	1607.00
3.00	2.9	4.06	58	80	7g	-2803D	1310.00
4.00	3.9	5.26	38	93	9g	-2804E	1553.00
5.00	4.9	6.36	73	100	48g	-2805F	1672.00
6.00	5.9	8.00	105	135	38g	-2806G	1964.00

Diameter (mm)	Dia. Range		Flute Length	Overall Length	Weight each	Order Code SHR-065	Price/1 TB
	min	max					
8.00	7.9	10.80	145	180	39g	-2807H	2380.00
10.00	9.9	13.40	175	215	89g	-2808J	3451.00
12.00	11.8	16.00	210	255	145g	-2809K	3927.00
13.00	12.8	16.74	210	255	295g	-2810L	5117.00
14.00	13.8	17.74	210	255	355g	-2811M	7138.00
16.00	15.8	20.40	230	280	475g	-2812N	7972.00
20.00	19.8	24.80	250	310	814g	-2813P	11735.00

PRODUCTS ARE ONLY AVAILABLE VIA YOUR DISTRIBUTOR



HSS Slitting Saws
Fine/Coarse

High speed steel slitting saws are hollow ground to give the clearance necessary for deep cutting. Available in coarse and fine teeth, number of teeth specified below. Supplied with keyways as standard. Manufactured to **BS122**.



HSS

Metric

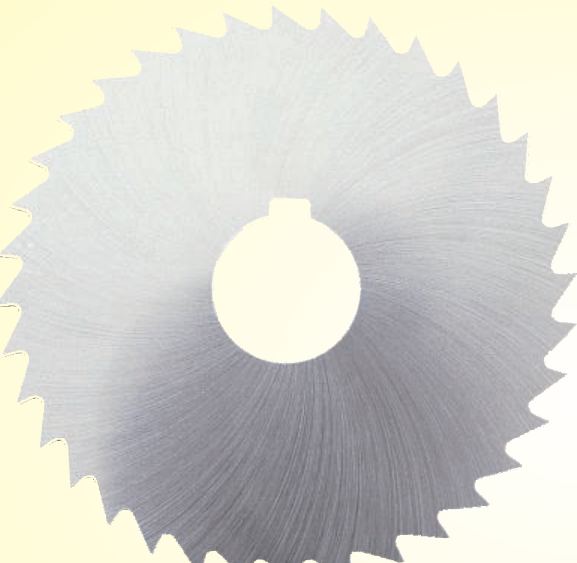

Diameter (mm)	Thickness	Bore	Teeth	Order Code SHR-072	Price/1 TB
25.00	0.50	8.0	64	-6025A	415.00
25.00	1.00	8.0	48	-6028D	500.00
25.00	1.60	8.0	40	-6030F	600.00
32.00	0.60	8.0	64	-6045Y	700.00
40.00	1.00	10.0	64	-6067X	900.00
40.00	1.60	10.0	64	-6069Z	950.00
50.00	2.00	13.0	64	-6098E	1050.00
63.00	0.40	16.0	128	-6112V	1075.00
63.00	1.00	16.0	100	-6121D	1100.00
80.00	1.00	22.0	100	-6149K	1200.00
80.00	2.00	22.0	80	-6155R	1300.00
80.00	3.00	22.0	80	-6159W	1400.00
100.00	1.00	22.0	128	-6176N	1500.00

Inch



Diameter (Inch)	Thickness	Bore	Teeth	Order Code SHR-072	Price/1 TB
2 1/2"	1/64"	1"	62	-5008Z	567.00
3"	1/64"	1"	74	-5020G	618.00
3"	1/32"	1"	74	-5020Q	618.00
3"	3/64"	1"	74	-5021R	773.00
3"	1/16"	1"	30	-5022N	824.00
3"	1/16"	1"	74	-5022S	824.00
3"	5/64"	1"	74	-5023T	876.00
3"	3/32"	1"	74	-5024V	618.00
3"	1/8"	1"	30	-5026S	618.00
4"	1/64"	1"	100	-5034X	1133.00
4"	3/64"	1"	100	-5036M	1442.00
4"	1/16"	1"	100	-5037N	1494.00
4"	1/8"	1"	36	-5041H	1494.00
5"	3/32"	1"	40	-5052V	1854.00



Industrial Quality
Screw Extractors

Recommended for simple, low cost removal of broken screws, bolts etc, without damaging the threads of the component.



Extractor Number	Inch diameter for removing screws sized	Weight each	Order Code KEN-075	Price/1 TB
1	3/32 to 5/32	40g	-1010K	86.00
2	5/32 to 7/32	80g	-1020K	92.00
3	7/32 to 9/32	160g	-1030K	103.00
4	9/32 to 3/8	40g	-1040K	109.00
5	3/8 to 5/8	70g	-1050K	155.00
6	5/8 to 7/8	130g	-1060K	211.00
7	7/8 to 1 1/8	210g	-1070K	301.00
8	1 1/8 to 1 3/8	410g	-1080K	314.00
9	1 3/8 & above	690g	-1090K	484.00

Screw Extractor Sets









4 Piece Sizes: No. 2, 3, 4 and 5.

6 Piece Sizes: No. 1, 2, 3, 4, 5 and 6.





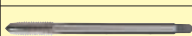
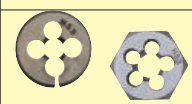





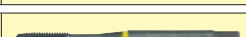
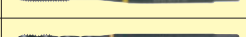
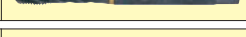

Number of Pieces	Weight each	Order Code KEN-075	Price/1 TB
4	130g	-1140K	450.00
6	250g	-1160K	677.00

HSS Hand Taps

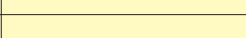
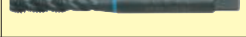
ISO 529	SHERWOOD		METRIC COARSE	METRIC FINE	UNC	UNF	BSW	BSF	BA	BSP	BSPT	NPT NPTF	NPS NPSF
HSS Ground Thread For Hand & General Use	Taper-Second Plug		Page 92	Page 94	Page 96	Page 98	Page 99	Page 100	Page 101	Page 102	Page 103	Page 104	Page 104
	Sets of Three		Page 92	Page 94	Page 96	Page 98	Page 99	Page 100	Page 101	Page 102	Page 103	*	*
	Spiral Point/ Gun Nose		Page 93	Page 95	Page 97	Page 98	Page 99	Page 100	Page 101	Page 102	*	*	*
	Spiral Flute		Page 93	Page 95	Page 97	Page 98	Page 99	Page 100	Page 101	Page 102	*	*	*
	Fluteless		Page 93	*	Page 97	*	*	*	*	*	*	*	*
	Long Series		Page 93	*	*	*	*	*	*	*	*	*	*
	Dies		Page 92	Page 94	Page 96	Page 98	Page 99	Page 167	Page 101	Page 102	Page 103	Page 94	Page 94
	Die Nuts		Page 92	Page 94	Page 96	Page 98	Page 99	Page 167	*	Page 102	Page 103	Page 94	Page 94
	Left Hand Taps & Dies		Page 93	*	*	*	*	*	*	*	*	*	*

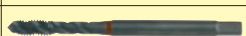
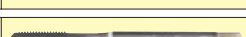
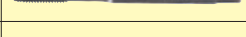
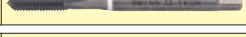
*Where indicated these products are not shown in this catalogue but can be supplied on request. Please contact your local branch for more information.

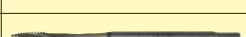
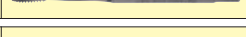
Production Taps

DIN 371/6	SWISS+TECH		METRIC COARSE	BSP
BLACK RING MULTI APPLICATION	Spiral Point For Through Holes		Page 108	-
	Spiral Flute For Blind Holes		Page 108	-
YELLOW RING FOR STEELS	Spiral Point For Through Holes		Page 109	Page 109
	Spiral Flute For Blind Holes		Page 109	Page 109
BLUE RING FOR STAINLESS	Spiral Point For Through Holes		Page 110	-
	Spiral Flute - BLF For Shorter Blind Holes		Page 110	-
	Spiral Flute - BLT For Deeper Blind Holes		Page 110	-
RED RING FOR ALLOY STEELS	Spiral Point For Through Holes		Page 109	-
	Spiral Flute For Blind Holes		Page 109	-
WHITE RING FOR CAST IRON	Straight Flute For Through Holes		Page 110	-
	Straight Flute For Blind Holes		Page 110	-
PURPLE RING FOR TITANIUM ALLOYS	Left Hand Spiral Flute For Through Holes		Page 111	-
	Spiral Flute For Blind Holes		Page 111	-
ORANGE RING FOR HI-TEMP ALLOYS	Spiral Point For Through Holes		Page 111	-
	Spiral Flute For Blind Holes		Page 111	-
GREEN RING FOR ALUMINIUM ALLOYS	Spiral Point For Through Holes		Page 112	-
	Spiral Flute For Blind Holes		Page 112	-
FOR BRASS/ALUMINIUM	Fluteless For Through & Blind Holes		Page 112	-

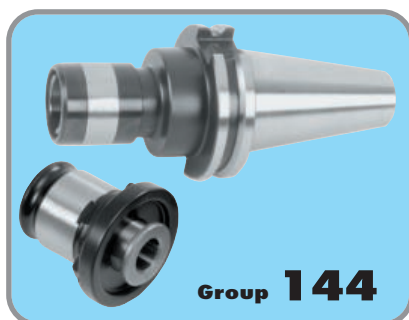
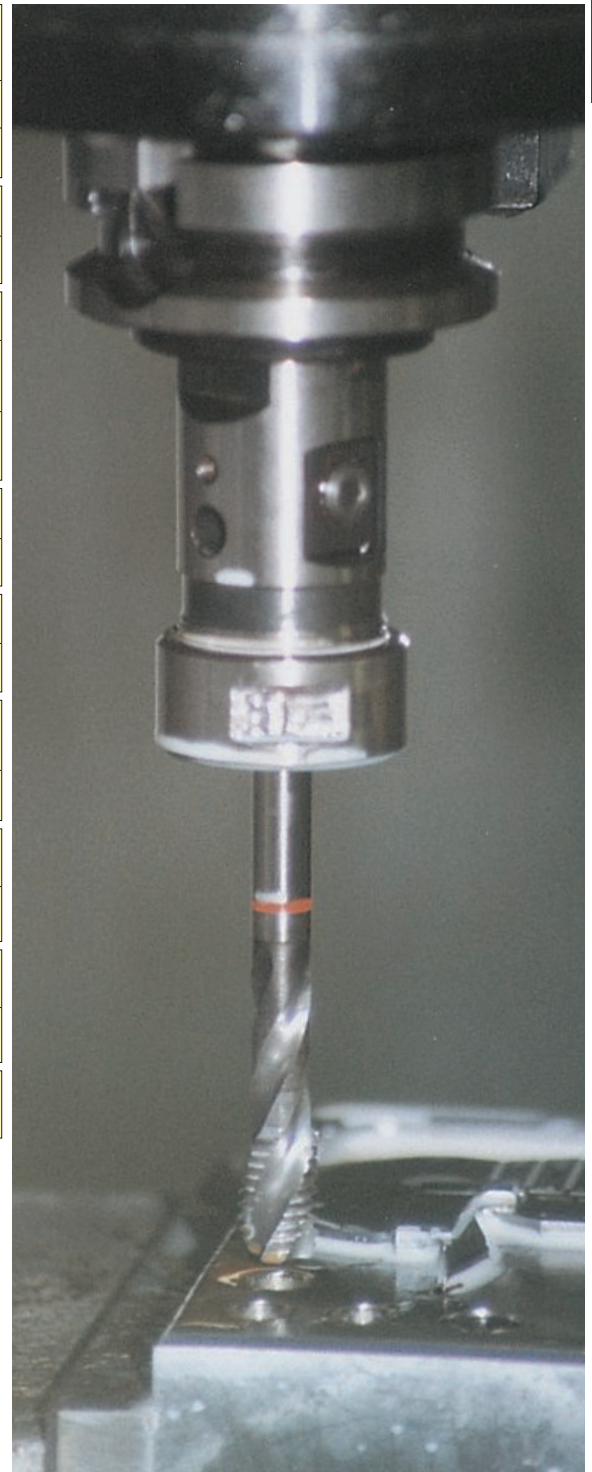

Group 144



Group 085

PRODUCTS ARE ONLY AVAILABLE VIA YOUR DISTRIBUTOR



Metric Fine HSS Ground Thread Taps

HSS

METRIC FINE

ISO 529

Spiral Point/Gun Nose

† = Metric Spark Plug
* = Metric Conduit



Size - Pitch (mm)	Shank Diameter	A/F Square	Weight each	Order Code SHR-085	Price/1 TB
Metric Fine					
M4.0 x 0.50	4.00	3.15	8g	-0270E	853.00
M5.0 x 0.50	5.00	4.00	10g	-0320E	1984.00
M6.0 x 0.75	6.30	5.00	27g	-0360E	1384.00
M8.0 x 1.00	8.00	6.30	23g	-0400E	1635.00
M10.0 x 1.25	10.00	8.00	40g	-0440E	2766.00
M12.0 x 1.25	9.00	7.10	48g	-0470E	3667.00
M14.0 x 1.50	11.20	9.00	78g	-0500E	3990.00
M16.0 x 1.50	12.50	10.00	82g	-0520E	3186.00
M18.0 x 1.50	14.00	11.20	132g	-0540E	6230.00
M20.0 x 1.50	14.00	11.20	159g	-0560E	8806.00
M22.0 x 1.50	16.00	12.50	185g	-0580E	8715.00
ISO Metric Special Pitch					
M10.0 x 1.00†	10.00	8.00	40g	-0430E	2105.00
M12.0 x 1.50	9.00	7.10	40g	-0475E	2465.00

Spiral Flute

METRIC FINE HSS

† = Metric Spark Plug
* = Metric Conduit



Size - Pitch (mm)	Shank Diameter	A/F Square	Weight each	Order Code SHR-085	Price/1 TB
Metric Fine					
M4.0 x 0.50	4.00	3.15	6g	-0270F	1203.00
M5.0 x 0.50	5.00	4.00	10g	-0320F	2525.00
M6.0 x 0.75	6.30	5.00	14g	-0360F	1864.00
M8.0 x 1.00	8.00	6.30	22g	-0400F	2165.00
M10.0 x 1.25	10.00	8.00	37g	-0440F	3307.00
M12.0 x 1.25	9.00	7.10	47g	-0470F	3968.00
M14.0 x 1.50	11.20	9.00	75g	-0500F	5109.00
M16.0 x 1.50	12.50	10.00	82g	-0520F	5290.00
M18.0 x 1.50†	14.00	11.00	148g	-0540F	7432.00
M20.0 x 1.50*	14.00	11.20	131g	-0560F	9071.00
M22.0 x 1.50	16.00	12.50	184g	-0580F	10278.00
ISO Metric Special Pitch					
M10.0 x 1.00†	10.00	8.00	38g	-0430F	2586.00
M12.0 x 1.50	9.00	7.10	48g	-0475F	3547.00
M14.0 x 1.25†	11.20	9.00	75g	-0490F	5304.00

HSS Ground Flute Tap & Drill Set

Industrial quality. Ground flute, blue finish. Supplied in indexing metal cases. Manufactured to BS328 : Part 1 : 1986, DIN 338N & ANSI B94 -11M.



HSS

METRIC COARSE



28 PIECES

METRIC Taps M3 ~ M12 + Tapping Drills 2.5 ~ 10.2

28 Piece Tap & Drill Set
Taps (Taper, Second and Bottom)

M3 M4	M5 M6	M8 M10	M12
Tapping Drills			
(mm) 2.5	3.3 4.2	5.0 6.8	8.5 10.2

Number of Pieces	Order Code SHR-025	Price/1 TB
28	-9960K	8755.00

Machine Tapping Speeds

Group	Materials Colour defines similar machineability	Hardness		Tensile Strength N/mm ²	Cutting Speed M/min	Hole Type	Tap Type
		Brinell HB	Rockwell HRC				
Carbon	1.1 Mild Steel	<130	-	<400	15 - 20	Various Through Hole Blind Hole	Straight Flute Spiral Point/ Gun Nose Spiral Flute
	1.2 Case Hardening & Structural Steel	<200	-	<700	15 - 20		
	1.3 Medium Carbon Steel	<260	<26	<850	15 - 20		
Alloy	1.4 Low Alloy Steel	<260	<26	<850	10 - 15	Through Hole Blind Hole	Spiral Point/ Gun Nose Spiral Flute
	1.5 Medium to High Alloy Steel	260 - 340	26 - 36	850 - 1200	6 - 10		
	1.6 Heat Treated Steel	340 - 450	36 - 48	1200 - 1500	4 - 6		
Stainless Steels	2.1 Free Machining Stainless	<230	<20	<800	8 - 10	Through Hole Blind Hole	Spiral Point/ Gun Nose Spiral Flute
	2.2 Medium Strength Austenitic Stainless	<290	<30	<1000	6 - 8		
	2.3 Difficult to Machine, Duplex Stainless	<340	<36	<1200	4 - 6		
Cast Iron	3.1 Grey Cast Iron - Soft	<180	-	-	18 - 25	Blind & Through Hole	Straight Flute
	3.2 Grey Cast Iron - Hard	180 - 300	-	-	15 - 18		
	3.3 Malleable & Nodular Iron	<220	-	-	8 - 12	Through Hole	Spiral Point/ Gun Nose
	3.4 Malleable & Nodular Iron - Hard	200 - 300	-	-	4 - 6		
Aluminium	7.1 Unalloyed Aluminium - Zinc - Magnesium	-	-	<150	20 - 25	Blind & Through Hole	Fluteless
	7.2 Aluminium Alloy less than 5% Si	-	-	150 - 300	17 - 22		
	7.3 Aluminium Alloy 5% to 10% Si	-	-	200 - 500	15 - 20		
	7.4 Aluminium Alloy above 10% Si	-	-	200 - 500	12 - 15		

Power Requirements For Taps

Many factors are involved when considering power requirements for a particular application. Factors such as the choice of tap design, tapping drill size, depth of threaded hole, lubricant and tapping speed all play a part in determining these requirements.

To estimate the power requirements for varying percentage thread depths, the following general formula and constants may be used:

$$\text{Tapping Power (KW)} = C \times D \times p^2 \times N \times K$$

$$\text{HP} = \frac{\text{KW} \times 1.341}{10000}$$

Where **D** = Thread Diameter (mm)
P = Pitch (mm)
N = Spindle speed RPM
K = Material Factor Constant
C = A constant based on % thread depth, as follows:

C	% Thread Depth
0.231	60
0.326	75
0.433	80

GROUP 085 HSS TAPS & DIES



UNC (Unified Coarse) HSS Ground Thread Taps

ISO 529

Left Hand Also Available

Sets of Three
1 each, taper, second and plug lead.



UNC HSS



Straight Flute Individual Sizes

Size - Pitch	Thread Length	Overall Length	Shank Diameter	Weight each	Taper	Second	Plug	Price/1 TB
					Order Code SHR-085	Order Code SHR-085	Order Code SHR-085	
No.1 x 64	8.0	41.0	2.50	3g	-0760A	-	-0760C	3077.00
No.2 x 56	9.5	44.5	2.80	3g	-0770A	-0770B	-0770C	1415.00
No.3 x 48	9.5	44.5	2.80	3g	-	-	-0780C	2121.00
No.4 x 40	11.0	48.0	3.15	3g	-0790A	-0790B	-0790C	984.00
No.5 x 40	11.0	48.0	3.15	4g	-0800A	-0800B	-0800C	940.00
No.6 x 32	13.0	50.0	3.55	4g	-0810A	-0810B	-0810C	743.00
No.8 x 32	13.0	53.0	4.50	7g	-0820A	-0820B	-0820C	691.00
No.10 x 24	16.0	58.0	5.00	8g	-0830A	-0830B	-0830C	772.00
No.12 x 24	17.0	62.0	5.60	11g	-0840A	-0840B	-0840C	1018.00
1/4" x 20	19.0	66.0	6.30	14g	-0850A	-0850B	-0850C	727.00
5/16" x 18	22.0	72.0	8.00	22g	-0860A	-0860B	-0860C	844.00
3/8" x 16	24.0	80.0	10.00	38g	-0870A	-0870B	-0870C	949.00
7/16" x 14	25.0	85.0	8.00	38g	-0880A	-0880B	-0880C	1513.00
1/2" x 13	29.0	89.0	9.00	50g	-0890A	-0890B	-0890C	1335.00
9/16" x 12	30.0	95.0	11.20	75g	-0900A	-0900B	-0900C	2279.00
5/8" x 11	32.0	102.0	12.50	82g	-0910A	-0910B	-0910C	2035.00
3/4" x 10	37.0	112.0	14.00	142g	-0920A	-0920B	-0920C	2966.00
7/8" x 9	38.0	118.0	16.00	193g	-0930A	-0930B	-0930C	4470.00
1" x 8	45.0	130.0	18.00	323g	-0940A	-0940B	-0940C	5157.00
1 1/8" x 7	48.0	138.0	20.00	373g	-0950A	-0950B	-	8594.00
1 1/4" x 7	51.0	151.0	22.40	478g	-	-0960B	-	7162.00
1 3/8" x 6	57.0	162.0	25.00	577g	-	-0970B	-	13791.00
1 1/2" x 6	60.0	170.0	28.00	782g	-0980A	-	-0980C	13905.00

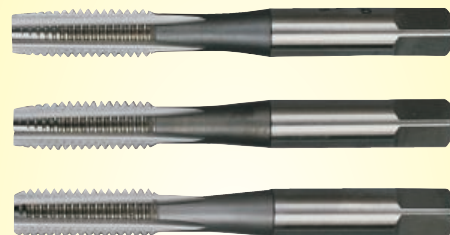

Square AF	Tap Drill Size	Set of 3	
		Order Code SHR-085	Price/1 TB
2.00	1.55	-0760D	9500.00
2.24	1.85	-0770D	3714.00
2.24	2.10	-	-
2.50	2.35	-0790D	3246.00
2.50	2.65	-0800D	2653.00
2.80	2.85	-0810D	2121.00
3.55	3.50	-0820D	1910.00
4.00	3.90	-0830D	2319.00
4.50	4.50	-0840D	3057.00
5.00	5.10	-0850D	2174.00
6.30	6.60	-0860D	2531.00
8.00	8.00	-0870D	2847.00
6.30	9.40	-0880D	4537.00
7.10	10.80	-0890D	4007.00
9.00	12.20	-0900D	6844.00
10.00	13.50	-0910D	6154.00
11.20	16.50	-0920D	8912.00
12.50	19.50	-0930D	13421.00
14.00	22.25	-0940D	15490.00
16.00	25.00	-	-
18.00	28.00	-	-
20.00	30.75	-	-
22.40	34.00	-	-

UNC (Unified Coarse) HSS Ground Thread Dies

UNC HSS

BS 1127

For use in diestocks to produce external screw threads.



Size - Pitch	Outside Diameter	Thickness	Weight each	Order Code SHR-086	Price/1 TB
No.2 x 56	13/16"	1/4"	12g	-2980K	3395.00
No.4 x 40	13/16"	1/4"	12g	-3000K	1242.00
No.6 x 32	13/16"	1/4"	7g	-3020K	1242.00
No.8 x 32	13/16"	1/4"	13g	-3030K	1242.00
No.10 x 24	13/16"	1/4"	17g	-3040K	1476.00
1/4" x 20	13/16"	3/8"	12g	-3060K	984.00
1/4" x 20	1"	3/8"	26g	-3220K	1164.00
1/4" x 20	1 5/16"	7/16"	46g	-3340K	2100.00
5/16" x 18	1"	3/8"	27g	-3230K	1164.00
5/16" x 18	1 5/16"	7/16"	47g	-3350K	2100.00
3/8" x 16	1"	3/8"	24g	-3240K	2580.00
3/8" x 16	1 5/16"	7/16"	62g	-3360K	2100.00
7/16" x 14	1"	3/8"	27g	-3250K	1706.00
7/16" x 14	1 5/16"	7/16"	51g	-3370K	2100.00
1/2" x 13	1 5/16"	7/16"	52g	-3380K	2100.00
1/2" x 13	1 1/2"	1/2"	79g	-3480K	2580.00
9/16" x 12	1 5/16"	7/16"	37g	-3390K	3717.00
9/16" x 12	1 1/2"	1/2"	71g	-3490K	6365.00
5/8" x 11	1 1/2"	1/2"	71g	-3500K	2733.00
3/4" x 10	1 1/2"	1/2"	70g	-3510K	2842.00
7/8" x 9	2"	5/8"	149g	-3660K	2951.00
1" x 8	2"	5/8"	157g	-3670K	2951.00

UNC (Unified Coarse) HSS Ground Thread Die Nuts

UNC HSS

BS 1127

For use with spanners to clean and repair existing external screw threads.



Size - Pitch	Width	Thickness	Weight each	Order Code SHR-086	Price/1 TB
1/4" x 20	0.71"	1/4"	13g	-3920K	2525.00
5/16" x 18	0.82"	5/16"	12g	-3950K	3006.00
3/8" x 16	0.92"	3/8"	11g	-3970K	3426.00
7/16" x 14	1.01"	7/16"	33g	-3990K	4749.00
1/2" x 13	1.10"	1/2"	45g	-4010K	4148.00
1/2" x 13	1.10"	1/2"	44	-4020K	6011.00
5/8" x 11	1.30"	5/8"	72g	-4040K	5170.00
3/4" x 10	1.48"	1 1/16"	102g	-4070K	6432.00
1" x 8	2.05"	1 5/16"	269g	-4110K	10519.00



**UNC (Unified Coarse)
HSS Ground Thread Taps**

ISO 529

Spiral Point/Gun Nose

UNC HSS



Size - Pitch	Shank Dia.	A/F Square	Weight each	Order Code SHR-085	Price/1 TB
No.1 x 64	2.50	2.00	1g	-0760E	4243.00
No.2 x 56	2.80	2.24	1g	-0770E	1060.00
No.4 x 40	3.15	2.50	1g	-0790E	1910.00
No.5 x 40	3.15	2.50	2g	-0800E	2121.00
No.6 x 32	3.55	2.80	2g	-0810E	1221.00
No.8 x 32	4.50	3.55	4g	-0820E	1221.00
No.10 x 24	5.00	4.00	5g	-0830E	1301.00
No.12 x 24	5.60	4.50	8g	-0840E	1720.00
1/4" x 20	6.30	5.00	11g	-0850E	1130.00
5/16" x 18	8.00	6.30	17g	-0860E	1421.00
3/8" x 16	10.00	8.00	33g	-0870E	1594.00
7/16" x 14	8.00	6.30	38g	-0880E	2549.00
1/2" x 13	9.00	7.10	44g	-0890E	2254.00
9/16" x 12	11.20	9.00	62g	-0900E	3316.00
5/8" x 11	12.50	10.00	91g	-0910E	3430.00
3/4" x 10	14.00	11.20	130g	-0920E	4991.00
7/8" x 9	16.00	12.20	173g	-0930E	7533.00
1" x 8	18.00	14.00	294g	-0940E	8700.00

Fluteless

UNC HSS



Size-Pitch	Shank Diameter	Weight each	Order Code SHR-085	Price/1 TB
No.4 x 40	3.15	2g	-0790K	2733.00
No.6 x 32	3.55	3g	-0810K	2733.00
No.8 x 32	4.50	8g	-0820K	2842.00
1/4" x 20	6.30	11g	-0850K	2222.00
3/8" x 16	10.00	41g	-0870K	3206.00

Thread Restoring Files

Restore internal and external threads by filing, where the use of taps and dies are impractical. The restorer file overlaps several good threads and files the damaged ones. Restore right and left hand, internal and external threads. Long lasting, fast cutting teeth. Thread restoring files are available in ISO, Whit/BSF, UNF/UNC and BSP thread types.

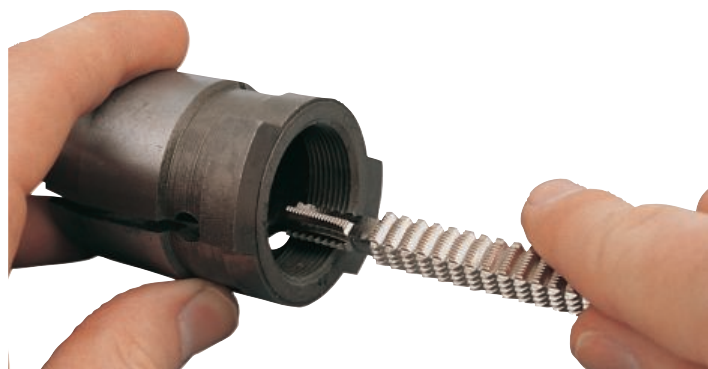

Spiral Flute

UNC HSS



Size - Pitch	Shank Dia.	A/F Square	Weight each	Order Code SHR-085	Price/1 TB
No.4 x 40	3.15	2.50	1g	-0790F	2334.00
No.5 x 40	3.15	2.50	2g	-0800F	2441.00
No.6 x 32	3.55	2.80	3g	-0810F	1486.00
No.8 x 32	4.50	3.55	4g	-0820F	1486.00
No.10 x 24	5.00	4.00	5g	-0830F	1591.00
No.12 x 24	5.60	4.50	8g	-0840F	2100.00
1/4" x 20	6.30	5.00	11g	-0850F	1412.00
5/16" x 18	8.00	6.30	19g	-0860F	1457.00
3/8" x 16	10.00	8.00	31g	-0870F	1868.00
7/16" x 14	8.00	6.30	31g	-0880F	3122.00
1/2" x 13	9.00	7.10	41g	-0890F	2261.00
5/8" x 11	12.50	10.00	89g	-0910F	4118.00
3/4" x 10	14.00	11.20	123g	-0920F	6101.00
7/8" x 9	16.00	12.50	180g	-0930F	8753.00
1" x 8	18.00	14.00	240g	-0940F	10663.00

UNC Threading Set

UNC HSS

No.10 - 3/4" UNC:

HSSGT Straight Flute Taps:

Taper: No. 10 x 24, 1/4" x 20, 5/16" x 18, 3/8" x 16.

Second: 7/16" x 14, 1/2" x 13, 5/8" x 11, 3/4" x 10.

Plug: No. 10 x 24, 1/4" x 20, 5/16" x 18, 3/8" x 16.

Bar Type Tap Wrenches: 1/16" - 1/4" and 1/4" - 3/4".

Tapping Drills to suit: HSS S/S.

3.90, 5.10, 6.60, 8.00, 9.40, 10.80mm

HSS 1" O/D Dies:

1/4" x 20, 5/16" x 18, 3/8" x 16.

Diestock:

1" O/D.

HSS Die Nuts:

7/16" x 14, 1/2" x 13, 5/8" x 11, 3/4" x 10.



Range	Number of Pieces	Order Code SHR-086	Price/1 TB
10 - 3/4" UNC	28	-9994K	17768.00

**28
PIECES**

HSS TAPS & DIES



BSW (British Standard Whitworth) HSS Ground Thread Taps

ISO 529



Left Hand Also Available



Straight Flute Individual Sizes

Size - Pitch	Thread Length	Overall Length	Shank Diameter	Weight each	Taper	Second	Plug	Price/1 TB
					Order Code SHR-085	Order Code SHR-085	Order Code SHR-085	
1/8" x 40	16.0	48.0	3.15	1g	-1320A	-1320B	-1320C	1456.00
5/32" x 32	13.0	53.0	4.00	4g	-1330A	-1330B	-1330C	1250.00
3/16" x 24	16.0	58.0	5.00	8g	-1340A	-1340B	-1340C	887.00
1/4" x 20	19.0	66.0	6.30	14g	-1360A	-1360B	-1360C	837.00
5/16" x 18	22.0	72.0	8.00	23g	-1370A	-1370B	-1370C	966.00
3/8" x 16	24.0	80.0	10.00	38g	-1380A	-1380B	-1380C	1183.00
7/16" x 14	25.0	85.0	8.00	37g	-1390A	-1390B	-1390C	1742.00
1/2" x 12	29.0	89.0	9.00	49g	-1400A	-1400B	-1400C	1538.00
9/16" x 12	30.0	95.0	11.20	67g	-1410A	-1410B	-1410C	2500.00
5/8" x 11	32.0	102.0	12.50	98g	-1420A	-1420B	-1420C	2341.00
3/4" x 10	37.0	112.0	14.00	143g	-1430A	-1430B	-1430C	3406.00
7/8" x 9	38.0	118.0	16.00	195g	-1440A	-1440B	-1440C	5202.00
1" x 8	45.0	130.0	18.00	269g	-1450A	-1450B	-1450C	5942.00
1 1/4" x 7	51.0	151.0	22.40	473g	-	-	-1470C	16180.00

Sets of Three

1 each, taper, second and plug lead.

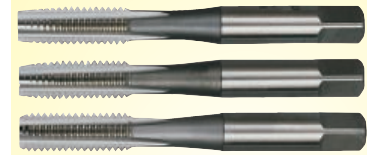

HSS
BSW

Square AF	Tap Drill Size	Set of 3	Price/1 TB
		Order Code SHR-085	
2.50	2.55	-1320D	4360.00
3.15	3.10	-1330D	2971.00
4.00	3.70	-1340D	2661.00
5.00	5.10	-1360D	2502.00
6.30	6.50	-1370D	2894.00
8.00	7.90	-1380D	3549.00
6.30	9.30	-1390D	5205.00
7.10	10.50	-1400D	4613.00
9.00	12.10	-	-
10.00	13.50	-1420D	7056.00
11.20	16.25	-1430D	10239.00
12.50	19.25	-1440D	15649.00
14.00	22.00	-1450D	17824.00
18.00	28.00	-1470D	47211.00

BSW (British Standard Whitworth) HSS Ground Thread Taps

ISO 529

Spiral Point/Gun Nose



Size - Pitch	Shank Dia.	A/F Square	Weight each	Order Code SHR-085	Price/1 TB
1/8" x 40	3.15	2.50	3g	-1320E	2288.00
3/16" x 24	5.00	4.00	8g	-1340E	1396.00
1/4" x 20	6.30	5.00	15g	-1360E	1317.00
5/16" x 18	8.00	6.30	23g	-1370E	1523.00
3/8" x 16	10.00	8.00	38g	-1380E	1863.00
7/16" x 14	8.00	6.30	25g	-1390E	2745.00
1/2" x 12	9.00	7.10	49g	-1400E	2424.00
5/8" x 11	12.50	10.00	62g	-1420E	3942.00
3/4" x 10	14.00	11.20	85g	-1430E	5783.00
1" x 8	18.00	14.00	221g	-1450E	10079.00

Spiral Flute



Size - Pitch	Shank Dia.	A/F Square	Weight each	Order Code SHR-085	Price/1 TB
1/8" x 40	3.15	2.50	2g	-1320F	2759.00
3/16" x 24	5.00	4.00	6g	-1340F	1714.00
1/4" x 20	6.30	5.00	14g	-1360F	1610.00
5/16" x 18	8.00	6.30	26g	-1370F	1863.00
3/8" x 16	10.00	8.00	37g	-1380F	2275.00
7/16" x 14	8.00	6.30	21g	-1390F	2936.00
1/2" x 12	9.00	7.10	46g	-1400F	2962.00
5/8" x 11	12.50	10.00	60g	-1420F	4999.00
3/4" x 10	14.00	11.20	75g	-1430F	7056.00

BSW Threading Set

3/16" - 3/4" BSW:

HSSGT Straight Flute Taps:

Taper: 3/16" x 24, 1/4" x 20, 5/16" x 18, 3/8" x 16.

Second: 7/16" x 14, 1/2" x 12, 5/8" x 11, 3/4" x 10.

Plug: 3/8" x 16, 5/16" x 18,

1/4" x 20, 3/16" x 24.

Bar Type Tap Wrenches:

1/4" - 3/4" and 1/16" - 1/4".

Tapping Drills to Suit:

HSS S/S: 3.70, 5.10, 6.50, 7.90, 9.30, 10.50mm.

HSS 1" O/D Dies:

1/4" x 2, 5/16" x 18 and 3/8" x 16.

Diestock: 1" O/D.

HSS Die Nuts: 7/16" x 14, 1/2" x 12, 5/8" x 11 and 3/4" x 10.



Range	Number of Pieces	Order Code SHR-086	Price/1 TB
3/16" - 3/4" BSW	28	-9992K	17768.00

BSW **HSS**

28
PIECES

BSW (British Standard Whitworth) HSS Ground Thread Dies

BS 1127

For use in diestocks to produce external screw threads.

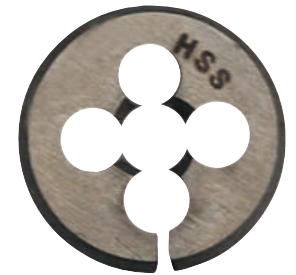

Size - Pitch	Outside Diameter	Thickness	Weight each	Order Code SHR-086	Price/1 TB
1/8" x 40	13/16"	1/4"	13g	-5600K	1394.00
3/16" x 24	13/16"	1/4"	12g	-5620K	1394.00
1/4" x 20	13/16"	1/4"	12g	-5640K	1313.00
1/4" x 20	1"	3/8"	27g	-5730K	1313.00
5/16" x 18	1"	3/8"	27g	-5740K	1313.00
3/8" x 16	1"	3/8"	26g	-5750K	1313.00
3/8" x 16	1 5/16"	7/16"	54g	-5810K	1531.00
7/16" x 14	1 5/16"	7/16"	53g	-5820K	1640.00
1/2" x 12	1 5/16"	7/16"	53g	-5830K	1935.00
1/2" x 12	1 1/2"	1/2"	52g	-5940K	5040.00
5/8" x 11	1 1/2"	1/2"	71g	-5960K	2257.00
3/4" x 10	1 1/2"	1/2"	66g	-5980K	2897.00
3/4" x 10	2"	5/8"	158g	-6120K	2897.00
7/8" x 9	2"	5/8"	135g	-6140K	3226.00
1" x 8	2"	5/8"	140g	-6160K	4208.00

BSW (British Standard Whitworth) HSS Ground Thread Die Nuts

BS 1127

For use with spanners to clean and repair existing external screw threads.



Size - Pitch	Width	Thickness	Weight each	Order Code SHR-086	Price/1 TB
1/8" x 40	0.71"	1/4"	13g	-6450K	4675.00
3/16" x 24	0.71"	1/4"	11g	-6470K	3006.00
1/4" x 20	0.71"	1/4"	10g	-6490K	3006.00
5/16" x 18	0.82"	5/16"	16g	-6570K	3006.00
3/8" x 16	0.92"	3/8"	25g	-6590K	4148.00
7/16" x 14	1.01"	7/16"	35g	-6610K	4646.00
1/2" x 12	1.10"	1/2"	44g	-6630K	4990.00
5/8" x 11	1.30"	5/8"	78g	-6660K	6257.00
3/4" x 10	1.48"	1 1/16"	102g	-6700K	7634.00
1" x 8	2.05"	1 5/16"	265g	-6780K	12458.00

PRODUCTS ARE ONLY AVAILABLE VIA YOUR DISTRIBUTOR



BSF (British Standard Fine) HSS Ground Thread Taps

ISO 529



Straight Flute Individual Sizes

Size - Pitch	Thread Length	Overall Length	Shank Diameter	Weight each	Taper			Price/1 TB
					Order Code SHR-085	Order Code SHR-085	Order Code SHR-085	
3/16" x 32	16.0	58.0	5.0	8g	-1600A	-1600B	-1600C	1017.00
1/4" x 26	19.0	66.0	6.3	14g	-1610A	-1610B	-1610C	944.00
5/16" x 22	22.0	72.0	8.0	23g	-1630A	-1630B	-1630C	1092.00
3/8" x 20	24.0	80.0	10.0	38g	-1640A	-1640B	-1640C	1333.00
7/16" x 18	25.0	85.0	8.0	24g	-1650A	-1650B	-1650C	1966.00
1/2" x 16	29.0	89.0	9.0	30g	-1660A	-1660B	-1660C	1739.00
5/8" x 14	32.0	102.0	12.5	60g	-	-1680B	-1680C	2646.00
3/4" x 12	37.0	112.0	14.0	85g	-1690A	-1690B	-1690C	3849.00
7/8" x 11	38.0	118.0	16.0	187g	-1700A	-1700B	-1700C	5835.00
1" x 10	45.0	130.0	18.0	266g	-1710A	-1710B	-	6684.00
1 1/2" x 8	60.0	170.0	28.0	402g	-	-1740B	-1740C	25568.00
1 3/4" x 7	67.0	187.0	31.5	603g	-1750A	-1750B	-1750C	40633.00

Left Hand Also Available

Sets of Three

1 each, taper, second and plug lead.



BSF HSS

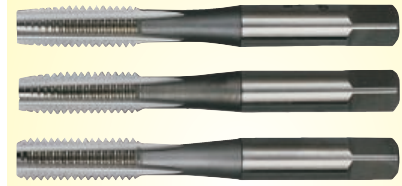

Square AF	Tap Drill Size	Set of 3	
		Order Code SHR-085	Price/1 TB
4.00	4.00	-1600D	3051.00
5.00	5.30	-1610D	2833.00
6.30	6.80	-1630D	3276.00
8.00	8.30	-1640D	4002.00
6.30	9.70	-1650D	5889.00
7.10	11.10	-1660D	5205.00
10.00	14.00	-1680D	7957.00
11.20	15.50	-1690D	11564.00
12.50	19.75	-1700D	17453.00
14.00	22.75	-	-
22.40	34.50	-	-
25.00	40.50	-	-

BSF (British Standard Fine) HSS Ground Thread Dies

BS 1127

For use in diestocks to produce external screw threads.

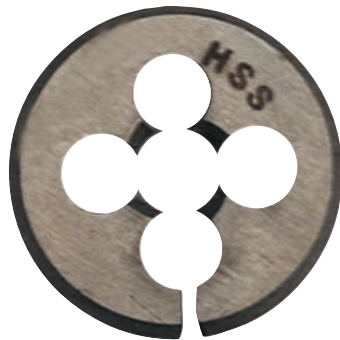

Size - Pitch	Outside Diameter	Thickness	Weight each	Order Code SHR-086	Price/1 TB
3/16" x 32	13/16"	1/4"	12g	-6950K	3607.00
1/4" x 26	13/16"	1/4"	12g	-6980K	2586.00
1/4" x 26	1"	3/8"	27g	-7020K	3066.00
5/16" x 22	1"	3/8"	27g	-7030K	3066.00
3/8" x 20	1"	3/8"	26g	-7040K	3066.00
3/8" x 20	1 5/16"	7/16"	51g	-7100K	4509.00
7/16" x 18	1 5/16"	7/16"	56g	-7110K	4509.00
1/2" x 16	1 5/16"	7/16"	54g	-7120K	4509.00
5/8" x 14	1 1/2"	1/2"	73g	-7250K	5290.00

BSF HSS

BSF (British Standard Fine) HSS Ground Thread Die Nuts

BS 1127

For use with spanners to clean and repair existing external screw threads.



Size - Pitch	Width	Thickness	Weight each	Order Code SHR-086	Price/1 TB
1/4" x 26	0.71"	1/4"	10g	-7720K	3006.00
3/8" x 20	0.92"	3/8"	24g	-7780K	4099.00
1/2" x 16	1.10"	1/2"	48g	-7820K	4973.00
5/8" x 14	1.30"	5/8"	78g	-7850K	6230.00
3/4" x 12	1.48"	11/16"	108g	-7890K	7649.00
7/8" x 11	1.67"	13/16"	149g	-7920K	8742.00
1" x 10	2.05"	15/16"	274g	-7940K	12568.00

BSF HSS

BSF (British Standard Fine) HSS Ground Thread Taps

ISO 529

Spiral Point/Gun Nose



Size - Pitch	Shank Dia.	A/F Square	Weight each	Order Code SHR-085	Price/1 TB
3/16" x 32	5.0	4.0	8g	-1600E	1695.00
1/4" x 26	6.3	5.0	15g	-1610E	1591.00
5/16" x 22	8.0	6.3	23g	-1630E	1847.00
3/8" x 20	10.0	8.0	40g	-1640E	2249.00
7/16" x 18	8.0	6.3	35g	-1650E	3316.00
1/2" x 16	9.0	7.1	54g	-1660E	2928.00
9/16" x 16	11.2	9.0	70g	-1670E	3498.00
5/8" x 14	12.5	10.0	100g	-1680E	5359.00
3/4" x 12	14.0	11.2	143g	-1690E	8276.00

BSF HSS

BSF (British Standard Fine) HSS Ground Thread Taps

ISO 529

Spiral Flute



Size - Pitch	Shank Dia.	A/F Square	Weight each	Order Code SHR-085	Price/1 TB
3/16" x 32	5.0	4.0	8g	-1600F	2071.00
1/4" x 26	6.3	5.0	15g	-1610F	1949.00
5/16" x 22	8.0	6.3	23g	-1630F	2255.00
3/8" x 20	10.0	8.0	40g	-1640F	2751.00
7/16" x 18	8.0	6.3	40g	-1650F	4054.00
1/2" x 16	9.0	7.1	50g	-1660F	3580.00
5/8" x 14	12.5	10.0	99g	-1680F	6790.00
3/4" x 12	14.0	11.2	120g	-1690F	10079.00

BSF HSS



**BA (British Association)
HSS Ground Thread Taps**

ISO 529

**Left Hand
Also
Available**



ISO 529 - 1975 (E)

Nominal Dia. of Tap	Maximum Deviation on Thread Length
Over -	5.5mm
5.5mm	12.0mm
12.0mm	39.0mm
39.0mm	-



Straight Flute Individual Sizes

Size - Pitch	Shank Diameter	Weight each	Taper Order Code SHR-085	Second Order Code SHR-085	Plug Order Code SHR-085	Price/1 TB
No.0 x 0.0394	6.30	14g	-1800A	-1800B	-1800C	826.00
No.2 x 0.0319	5.00	8g	-1820A	-1820B	-1820C	610.00
No.3 x 0.0287	4.50	7g	-1830A	-1830B	-1830C	1268.00
No.4 x 0.0260	3.55	4g	-1840A	-1840B	-1840C	625.00
No.5 x 0.0232	3.15	4g	-1850A	-1850B	-1850C	969.00
No.6 x 0.0209	2.80	3g	-1860A	-1860B	-1860C	684.00
No.8 x 0.0169	2.80	3g	-1880A	-1880B	-1880C	1243.00

Sets of Three

1 each, taper, second and plug lead.

BA HSS

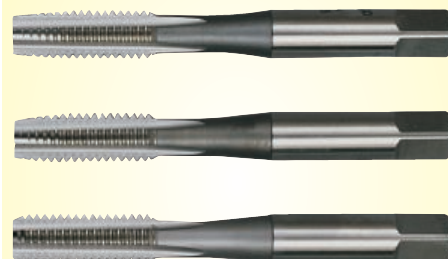

Square AF	Tap Drill Size	Set of 3 Order Code SHR-085	Price/1 TB
5.00	5.10	-1800D	2474.00
4.00	4.00	-1820D	1851.00
3.55	3.40	-1830D	3806.00
2.80	3.00	-1840D	1868.00
2.50	2.65	-1850D	2899.00
2.24	2.30	-1860D	2049.00
2.24	1.80	-1880D	3730.00

Spiral Point/Gun Nose

BA HSS



Size - Pitch	Shank Dia.	A/F Square	Weight each	Order Code SHR-085	Price/1 TB
No.0 x 0.0394	6.30	5.00	15g	-1800E	1750.00
No.1 x 0.0354	5.60	4.50	11g	-1810E	1972.00
No.2 x 0.0319	5.00	4.00	9g	-1820E	1024.00
No.4 x 0.0260	3.55	2.80	4g	-1840E	1049.00
No.5 x 0.0232	3.15	2.50	4g	-1850E	1910.00
No.6 x 0.0209	2.80	2.24	3g	-1860E	1156.00
No.8 x 0.0169	2.80	2.24	3g	-1880E	2093.00

**BA (British Association)
HSS Ground Thread Dies**

BA HSS

BS 1127

For use in diestocks to produce external screw threads.



Spiral Flute

BA HSS



Size - Pitch	Shank Dia.	A/F Square	Weight each	Order Code SHR-085	Price/1 TB
No.0 x 0.0394	6.30	5.00	14g	-1800F	1621.00
No.2 x 0.0319	5.00	4.00	6g	-1820F	1255.00
No.3 x 0.0287	4.50	3.55	5g	-1830F	1972.00
No.4 x 0.0260	3.55	2.80	4g	-1840F	1281.00
No.6 x 0.0209	2.80	2.24	3g	-1860F	1409.00
No.8 x 0.0169	2.80	2.24	3g	-1880F	2563.00

Pitch	Outside Diameter	Thickness	Weight each	Order Code SHR-086	Price/1 TB
No.6	13/16"	1/4"	11g	-8200K	3186.00
No.5	13/16"	1/4"	10g	-8210K	4453.00
No.4	13/16"	1/4"	12g	-8220K	3251.00
No.2	13/16"	1/4"	12g	-8240K	3251.00
No.1	13/16"	1/4"	13g	-8250K	3251.00

Sherwood STD

Spray
400ml foam aerosol penetrates and is able to cling to normally inaccessible areas and moving cutting edges.



Sherwood STD Liquid (Poly Bottle)
Low odour liquid. Coats the cutting edge with a film of EP additives.

Sherwood STD Compound
Low melting point paste maintains a continual lubricant feed to the cutting edge. Hand applied. Suitable for the most severe cutting operations.



Lubricant Type	Size	Order Code SHR-732	Price/1 TB
Liquid	500ml	-4020K	693.00
Liquid	5ltr	-4060K	5665.00
Compound	500g	-4040K	568.00

STD Tapping & Drilling Non-Soluble Foam Lubricant
Foam aerosol penetrates and is able to cling to normally inaccessible areas and moving cutting edges. Can be used on yellow metals without the risk of staining.



Lubricant Type	Size	Order Code SHR-732	Price/1 TB
Foam	400ml	-4210K	387.00



BSP(F) (British Standard Pipe Fitting) HSS Ground Thread Taps

Left Hand Also Available

Sets of Three
1 each, taper, second and plug lead.



BSP HSS

ISO 529



Straight Flute Individual Sizes

Size - Pitch	Thread Length	Overall Length	Shank Diameter	Weight each	Taper	Second	Plug	Price/1 TB
					Order Code SHR-085	Order Code SHR-085	Order Code SHR-085	
1/8" x 28	15.0	59.0	8.0	26g	-2010A	-2010B	-2010C	1047.00
1/4" x 19	19.0	67.0	10.0	47g	-2020A	-2020B	-2020C	1400.00
3/8" x 19	21.0	75.0	12.5	75g	-2030A	-2030B	-2030C	2076.00
1/2" x 14	26.0	87.0	16.0	137g	-2040A	-2040B	-2040C	2942.00
5/8" x 14	26.0	91.0	18.0	191g	-2050A	-2050B	-2050C	4660.00
3/4" x 14	28.0	96.0	20.0	228g	-2060A	-2060B	-2060C	4374.00
7/8" x 14	29.0	102.0	22.4	228g	-	-2070B	-	7799.00
1" x 11	33.0	109.0	25.0	446g	-2080A	-2080B	-2080C	7321.00
1 1/4" x 11	36.0	119.0	31.5	775g	-2090A	-2090B	-2090C	13050.00
1 1/2" x 11	37.0	125.0	35.5	1024g	-2100A	-2100B	-2100C	16551.00

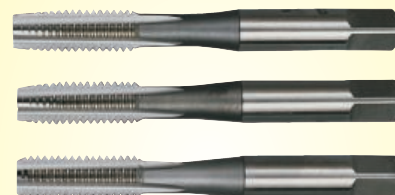

Square AF	Tap Drill Size	Set of 3	Price/1 TB
		Order Code SHR-085	
6.30	8.80	-2010D	2996.00
8.00	11.80	-2020D	4140.00
10.00	15.25	-2030D	6313.00
12.50	19.00	-2040D	8647.00
14.00	21.00	-2050D	14004.00
16.00	24.50	-2060D	13156.00
18.00	28.25	-	-
20.00	30.75	-2080D	21961.00
25.00	39.50	-2090D	39148.00
28.00	45.00	-2100D	49598.00

BSP(F) (British Standard Pipe Fine) HSS Ground Thread Taps

ISO 529

BSP HSS

Spiral Point/Gun Nose



Size - Pitch	Shank Dia.	A/F Square	Weight each	Order Code SHR-085	Price/1 TB
1/8" x 28	8.0	6.3	24g	-2010E	2413.00
1/4" x 19	10.0	8.0	51g	-2020E	3033.00
3/8" x 19	12.5	10.0	85g	-2030E	5067.00
1/2" x 14	16.0	12.5	143g	-2040E	7002.00
3/4" x 14	20.0	16.0	250g	-2060E	8329.00

BSP(F) (British Standard Pipe Fitting) HSS Ground Thread Taps

ISO 529

BSP HSS

Spiral Flute



Size - Pitch	Shank Dia.	A/F Square	Weight each	Order Code SHR-085	Price/1 TB
1/8" x 28	8.0	6.3	24g	-2010F	2567.00
1/4" x 19	10.0	8.0	51g	-2020F	3224.00
3/8" x 19	12.5	10.0	85g	-2030F	5231.00
1/2" x 14	16.0	12.5	143g	-2040F	7162.00
3/4" x 14	20.0	16.0	250g	-2060F	11883.00

BSP(F) (British Standard Pipe Fitting) HSS Ground Thread Dies

BS 1127

BSP HSS

For use in diestocks to produce external screw threads.



Size - Pitch	Outside Diameter	Thickness	Weight each	Order Code SHR-086	Price/1 TB
1/8" x 28	1"	3/8"	26g	-8620K	2705.00
1/8" x 28	1 5/16"	7/16"	50g	-8640K	4809.00
1/4" x 19	1 9/16"	7/16"	50g	-8650K	4088.00
1/4" x 19	1 1/2"	1/2"	76g	-8690K	5590.00
3/8" x 19	1 1/2"	1/2"	75g	-8700K	4689.00
1/2" x 14	2"	5/8"	158g	-8760K	7032.00
3/4" x 14	2"	5/8"	144g	-8780K	8743.00
1" x 11	2 1/4"	1 1/16"	174g	-8860K	12021.00

BSP(F) (British Standard Pipe Fitting) HSS Ground Thread Die Nuts

BS 1127

BSP HSS

For use with spanners to clean and repair existing external screw threads.



Size - Pitch	Width	Thickness	Weight each	Order Code SHR-086	Price/1 TB
1/8" x 28	0.92"	3/8"	23g	-8940K	1313.00
1/4" x 19	1.10"	1/2"	43g	-8960K	1925.00
3/8" x 19	1.30"	5/8"	80g	-8980K	2242.00
1/2" x 14	1.67"	13/16"	161g	-9000K	3322.00
3/4" x 14	2.05"	15/16"	247g	-9040K	4197.00
1" x 11	2.58"	1 1/8"	428g	-9080K	9901.00
1 1/4" x 11	2.76"	1 1/4"	619g	-9100K	16064.00



**BSP(F)
Threading Set**

NEW

BSP HSS

CUTTING TOOLS

HSSGT Straight Flute Taps:

Taper: 1/8" x 28, 1/4" x 19, 3/8" x 19 and 1/2" x 14.

Second: 3/4" x 14.

Plug: 1/8" x 28, 1/4" x 19, 3/8" x 19 and 1/2" x 14.

Outside Diameter HSS Dies

BSPF x 1 5/16":

1/8" x 28, 1/4" x 19 and 3/8" x 19.

BSPF HSS Hexagon

Die Nuts: 1/2" x 14 and 3/4" x 14.

HSS Straight Shank Jobber

Drills: 8.80 and 11.80mm,

Parallel Shank Drills 1/2":

15.25, 19.00 and 24.50mm.

Holders: 1 5/16" outside diameter diestock.

Traditional Tap Wrenches:

1/16" - 1/4" and 1/4" - 3/4".

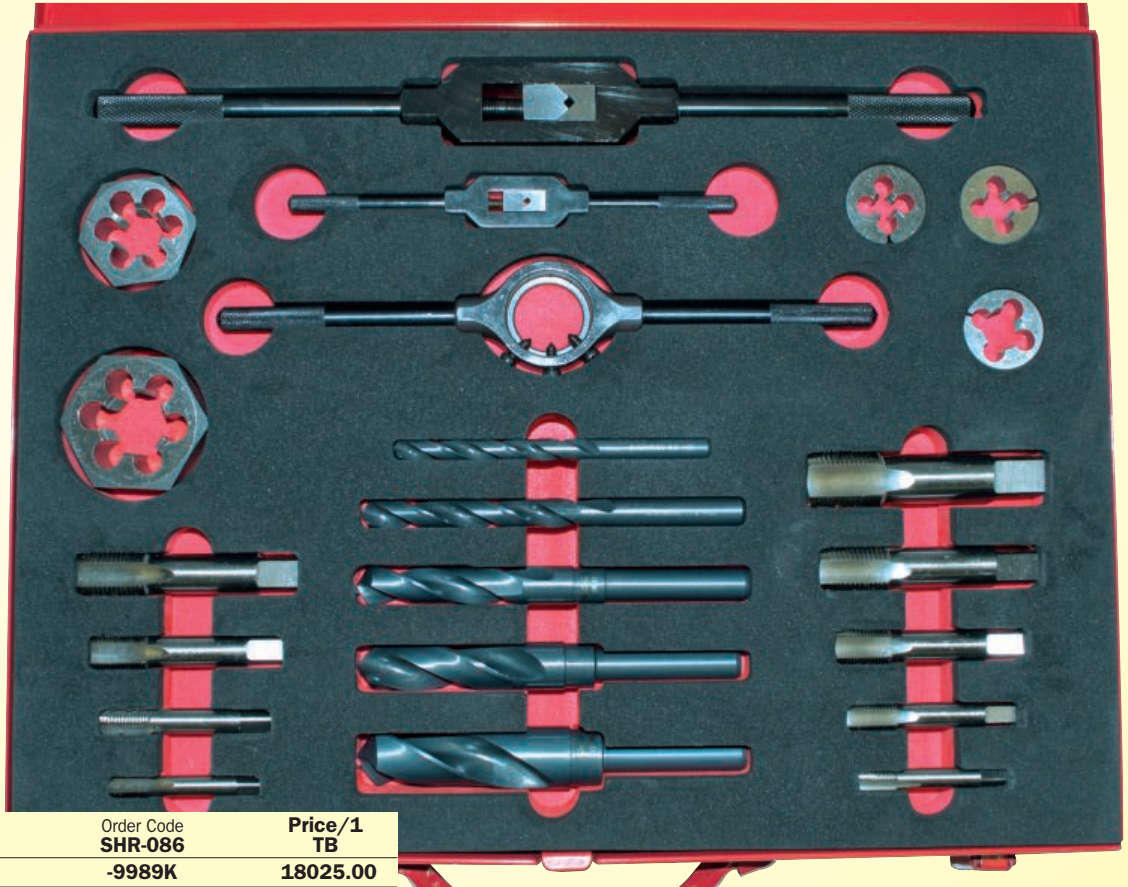

**22
PIECES**

Range	Number of Pieces	Order Code	Price/1 TB
1/16" - 3/4" BSPF	22	SHR-086 -9989K	18025.00

BSPT (British Standard Pipe Taper) HSS Ground Thread Taps

ISO 529

Straight Flute

BSPT HSS

Left Hand Also Available



R = With Reamer

NR = Without Reamer

Size - Pitch	Thread Length	Shank Diameter	Overall Length	Weight each	Square AF	Tap Drill Size R	Drill Size NR	Taper Order Code SHR-085	Second Order Code SHR-085	Plug Order Code SHR-085	Price/1 TB
1/8" x 28	15.0	8.0	59.0	29g	6.30	8.00	8.40	-	-	-2200C	1892.00
1/4" x 19	19.0	10.0	67.0	50g	8.00	10.80	11.20	-	-	-2210C	2527.00
3/8" x 19	21.0	12.5	75.0	66g	10.00	14.25	14.75	-	-	-2220C	3759.00
1/2" x 14	26.0	16.0	87.0	142g	12.50	17.75	18.25	-	-	-2230C	5300.00
3/4" x 14	28.0	20.0	96.0	241g	16.00	23.00	23.75	-	-	-2240C	7957.00
1" x 11	33.0	25.0	109.0	267g	20.00	29.00	30.00	-	-	-2250C	13262.00

BSPT (British Standard Pipe Taper) HSS Ground Thread Dies

ISO 2284

For use in diestocks to produce external screw threads.

BSPT HSS



Size - Pitch	Outside Diameter	Thickness	Weight each	Order Code	Price/1 TB
1/8" x 28	1"	3/8"	26g	-9150K	3497.00
1/4" x 19	1 5/16"	7/16"	62g	-9170K	4809.00
3/8" x 19	1 1/2"	1/2"	75g	-9200K	5764.00
1/2" x 14	2"	5/8"	175g	-9230K	6994.00

BSPT (British Standard Pipe Taper) HSS Ground Thread Die Nuts

BS 1127

For use with spanners to clean and repair existing external screw threads.

BSPT HSS

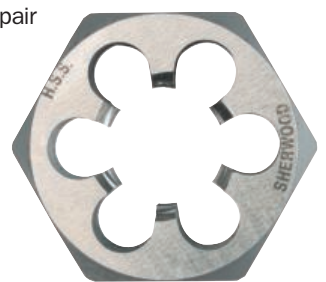
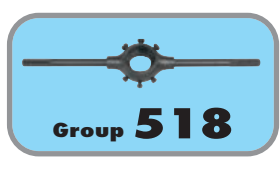

Size - Pitch	Width	Thickness	Weight each	Order Code	Price/1 TB
1/4" x 19	1.10"	1/2"	43g	-9310K	4809.00
3/8" x 19	1.30"	5/8"	80g	-9320K	7268.00
1/2" x 14	1.67"	13/16"	142g	-9330K	7374.00

PRODUCTS ARE ONLY AVAILABLE VIA YOUR DISTRIBUTOR

GROUP 085 HSS TAPS & DIES

SHERWOOD QUALITY CUTTING TOOLS **NPT (National Pipe Taper) HSS Ground Thread Taps**

ANSI 94.9
Straight Flute

Left Hand Also Available

Sets of Three
1 each, taper, second and plug lead.



NPT HSS



Size - Pitch	Thread Length	Overall Length	Shank Diameter	Weight each	Taper			Price/1 TB
					Order Code SHR-085	Order Code SHR-085	Order Code SHR-085	
1/16" x 27	1 1/16"	0.312	2 1/8"	20g	-	-	-3010C	1966.00
1/8" x 27	3/4"	0.437	2 1/8"	50g	-	-	-3020C	1715.00
1/4" x 18	1 1/16"	0.562	2 7/16"	70g	-	-	-3030C	2288.00
3/8" x 18	1 1/16"	0.700	2 9/16"	100g	-	-	-3040C	3406.00
1/2" x 14	1 3/8"	0.687	3 1/8"	180g	-	-	-3050C	4823.00
3/4" x 14	1 3/8"	0.906	3 1/4"	230g	-	-	-3060C	7162.00
1" x 11.5	1 3/4"	1.125	3 3/4"	420g	-	-	-3070C	11989.00
1 1/2" x 11.5	1 3/4"	1.500	4 1/2"	420g	-	-	-3090C	12875.00

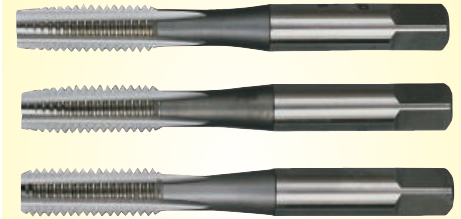

R = With Reamer
NR = Without Reamer

Set of 3						Order Code SHR-085	Price/1 TB
Square AF	Tap Drill R	Size NR	Order Code	Price/1 TB	Price/1 TB		
0.234	6.00	6.30	-	-	-		
0.328	8.40	8.70	-	-	-		
0.421	10.70	11.10	-3030D	6896.00	-		
0.531	14.25	14.50	-3040D	10079.00	-		
0.515	17.50	18.00	-	-	-		
0.679	22.75	23.25	-	-	-		
0.843	28.50	29.00	-3070D	19055.00	-		
1.125	43.50	44.00	-	-	-		

NPT (National Pipe Taper) HSS Ground Thread Die Nuts

NPT HSS

For use with spanners to clean and repair existing external screw threads.



Group 588



Size - Pitch	Width	Thickness	Weight each	Order Code SHR-086	Price/1 TB
1/4" x 18	1.10"	1/2"	51g	-9580K	4809.00
3/8" x 18	1.50"	5/8"	67g	-9590K	5764.00
1/2" x 14	1.67"	1 3/16"	147g	-9600K	9018.00
3/4" x 14	2.05"	1 5/16"	225g	-9610K	10079.00

NPT (National Pipe Taper) HSS Ground Thread Dies

NPT HSS

For use in diestocks to produce external screw threads.



Size - Pitch	Outside Diameter	Thickness	Weight each	Order Code SHR-086	Price/1 TB
1/8" x 27	1 5/16"	7/16"	44g	-9400K	3497.00
1/4" x 18	1 5/16"	7/16"	69g	-9410K	4809.00
1/4" x 18	1 1/2"	1/2"	88g	-9430K	5764.00
3/8" x 18	1 1/2"	1/2"	80g	-9440K	6695.00
1/2" x 14	2"	5/8"	159g	-9470K	6994.00
3/4" x 14	2"	5/8"	189g	-9480K	12875.00

Straight Flute Interrupted Thread

INTERRUPTED HSS

For reduced tapping friction.



Size - Pitch	Thread Length	Shank Diameter	Overall Length	Weight each	Order Code SHR-085	Price/1 TB
1/4" x 18	1 1/16"	0.562	2 7/16"	70g	-3220C	3816.00
3/8" x 18	1 1/16"	0.700	2 9/16"	100g	-3230C	5729.00
1/2" x 14	1 3/8"	0.687	3 1/8"	180g	-3240C	8063.00

NPTF (National Pipe Taper Fuel) HSS Ground Thread Taps

NPTF HSS

ANSI 94.9
Straight Flute



Size - Pitch	Thread Length	Shank Diameter	Overall Length	Weight each	Order Code SHR-085	Price/1 TB
1/16" x 27	1 1/16"	0.312	2 1/8"	20g	-3400C	2888.00
1/8" x 27	3/4"	0.437	2 1/8"	50g	-3410C	3508.00
1/4" x 18	1 1/16"	0.562	2 7/16"	91g	-3420C	3294.00
1/2" x 14	1 3/8"	0.687	3 1/8"	205g	-3440C	7109.00

NPSF (National Pipe Standard Fuel) HSS Ground Thread Taps

NPSF HSS

ANSI 94.9
Straight Flute



Size - Pitch	Thread Length	Overall Length	Shank Diameter	Weight each	Order Code SHR-085	Price/1 TB
1/8" x 27	3/4"	2 1/8"	0.437	45g	-2910C	2906.00
1/2" x 14	1 3/8"	3 1/8"	0.687	-	-2940C	5665.00
3/4" x 14	1 3/8"	3 1/4"	0.906	-	-2950C	9785.00
1" x 11.5	1 3/4"	3 3/4"	1.125	-	-2960C	20085.00

CUTTING TOOLS

SENATOR QUALITY TOOLING **Metric Threading Set**

HSS

Metric M3 - M12

Comprehensive threading set containing machine ground HSS Taps and Dies in a metal box.

Contents:

O/D Split Dies: M3, M4, M5, M6, M8, M10 and M12.

Ground Thread Taps (1 of each, taper, second and plug lead): M3, M4, M5, M6, M8, M10 and M12.

Bar Type Tap Wrench: M1 - M12 x 210mm.

Die Stock: 25 x 9 x 210mm.

Metric Thread Pitch Gauge.

Flat Bladed Screwdriver: 6mm.

**32
PIECES**



Range	Number of Pieces	Order Code	Price/1 TB
M3 - M12	32	SEN-086 -9980K	6632.00

Metric Threading Set

Metric M3 - M12

32 piece set of machine ground carbon steel taps and dies supplied in a metal box. For general workshop and maintenance use only.

CARBON STEEL

NEW

Contents:

O/D Split Dies: M3, M4, M5, M6, M8, M10 and M12.

Ground Thread Taps (1 of each, taper, second and plug lead): M3, M4, M5, M6, M8, M10 and M12.

Bar Type Tap Wrenches: M1 - M12 x 210mm.

Die Stock: 25 x 9 x 210mm.

Metric Thread Pitch Gauge.

Flat Bladed Screwdriver: 6mm.

**32
PIECES**



Range	Number of Pieces	Order Code	Price/1 TB
M3 - M12	32	SEN-086 -3990K	6350.00

SHERWOOD QUALITY CUTTING TOOLS **Metric Threading Set**



M2 - M16:

HSS Ground Thread

Taper and Second Taps:

M2 x 0.40, M3 x 0.50, M4 x 0.70, M5 x 0.80, M6 x 1.00, M8 x 1.25, M10 x 1.50 and M12 x 1.75.

Manufactured to **ISO 529**.

Bar Type Tap Wrenches: 1/16" - 1/4" and 3/16" - 1/2".

Tapping Drills to Suit: 1.6, 2.5, 3.3, 4.2, 5.0, 6.8, 8.5 and 10.2mm.

Made to **BS 328/DIN 338N**.

1 3/16" O/D Split Dies:

M2 x 0.40, M3 x 0.50, M4 x 0.70, M5 x 0.80 and M6 x 1.00.

1" O/D Split Dies:

M8 x 1.25 and M10 x 1.50. Manufactured to **BS 1127**.

Diastocks: 1 3/16" O/D and 1" O/D.

HSS Die Nuts: M12 x 1.75 and M16 x 2.00. Manufactured to **BS 1127**.

METRIC COARSE HSS

**37
PIECES**

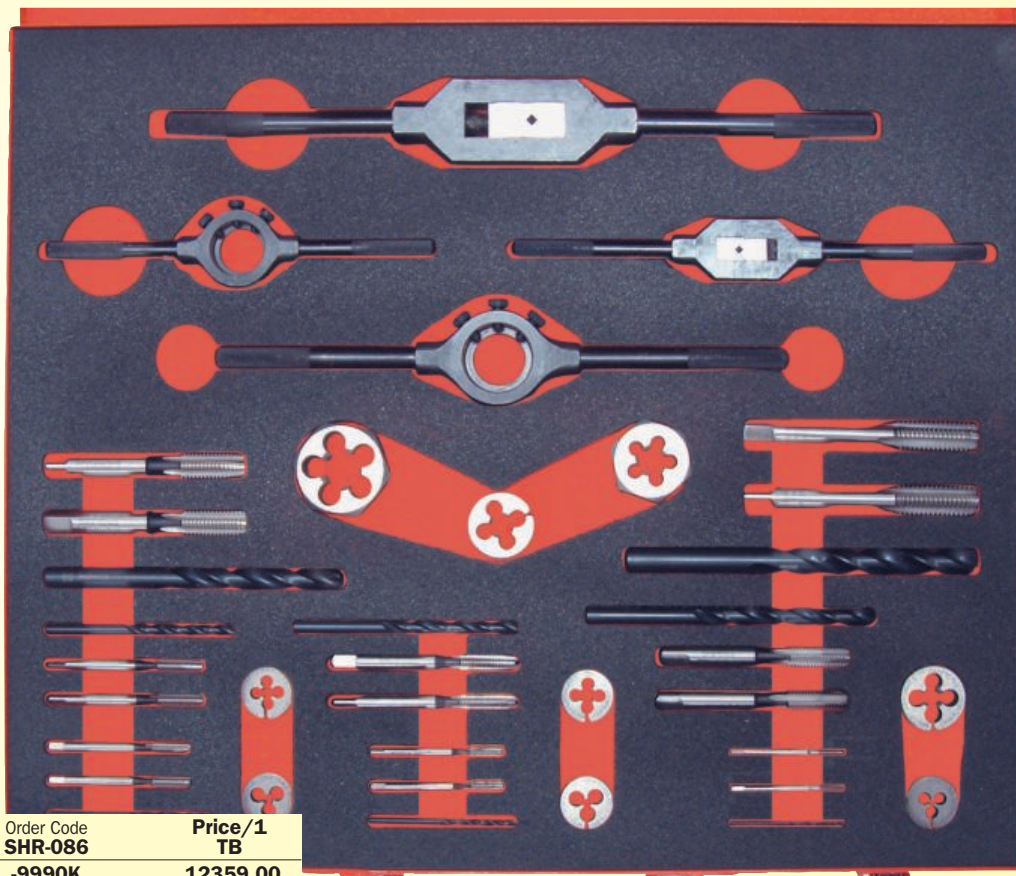

Range	Number of Pieces	Order Code	Price/1 TB
M2 - M16	37	SHR-086 -9990K	12359.00

PRODUCTS ARE ONLY AVAILABLE VIA YOUR DISTRIBUTOR



HSS

CUTTING TOOLS

EXTENDED RANGE

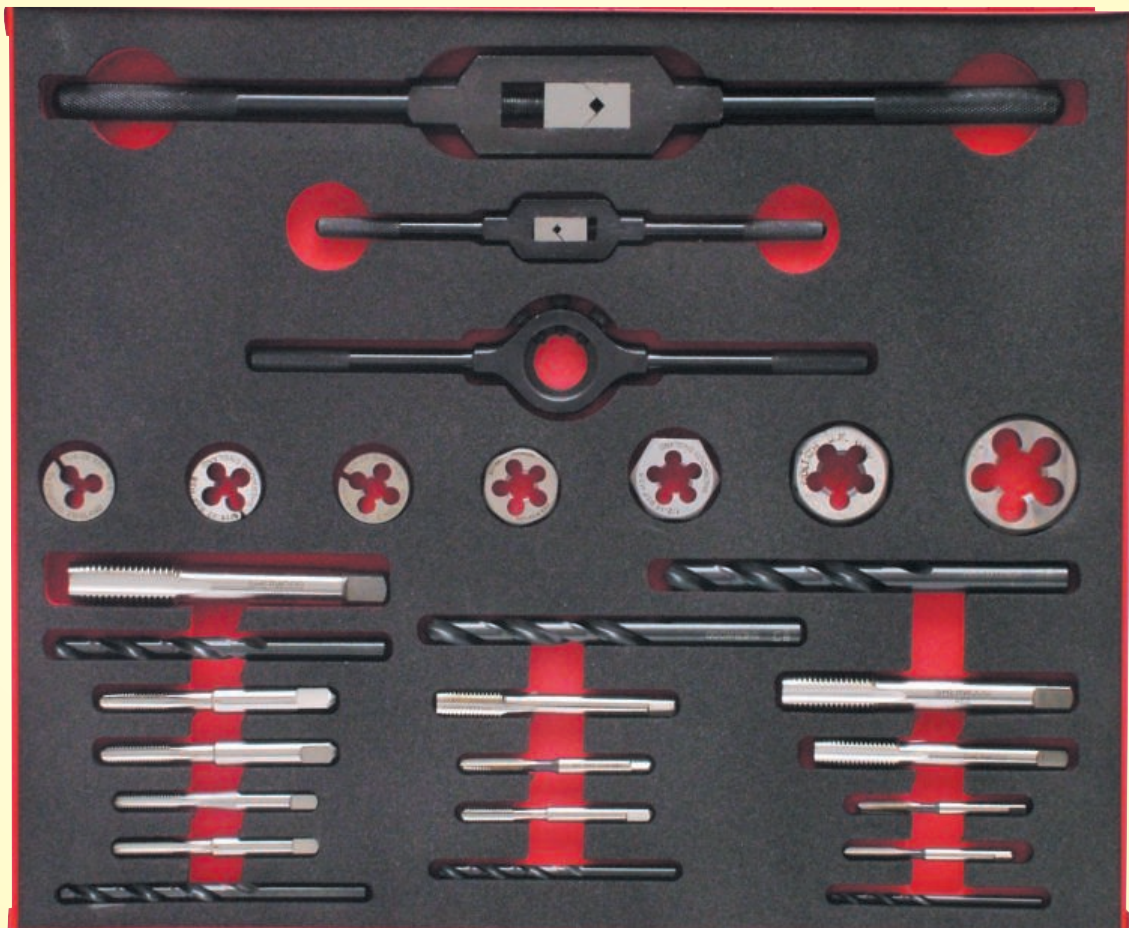

UNC, UNF, BSW, BSF and BSP(F) Sets

UNC Threading Set No.10 - 3/4" UNC:

HSSGT Straight Flute Taps:
Taper: No. 10 x 24, 1/4" x 20, 5/16" x 18, 3/8" x 16.
Second: 7/16" x 14, 1/2" x 13, 5/8" x 11, 3/4" x 10.
Plug: No.10 x 24, 1/4" x 20, 5/16" x 18, 3/8" x 16.
Bar Type Tap Wrenches: 1/16" - 1/4" and 1/4" - 3/4".
Tapping Drills to suit: HSS S/S. 3.90, 5.10, 6.60, 8.00, 9.40, 10.80mm
HSS 1" O/D Dies: 1/4" x 20, 5/16" x 18, 3/8" x 16.
Diestock: 1" O/D.
HSS Die Nuts: 7/16" x 14, 1/2" x 13, 5/8" x 11, 3/4" x 10.

Range	Number of Pieces	Order Code SHR-086	Price/1 TB
10 - 3/4" UNC	28	-9994K	17768.00

UNC
28
PIECES

BSW Threading Set 3/16" - 3/4" BSW:

HSSGT Straight Flute Taps:
Taper: 3/16" x 24, 1/4" x 20, 5/16" x 18, 3/8" x 16.
Second: 7/16" x 14, 1/2" x 12, 5/8" x 11, 3/4" x 10.
Plug: 3/8" x 16, 5/16" x 18, 1/4" x 20, 3/16" x 24.
Bar Type Tap Wrenches: 1/4" - 3/4" and 1/16" - 1/4".
Tapping Drills to Suit: HSS S/S. 3.70, 5.10, 6.50, 7.90, 9.30, 10.50mm
HSS 1" O/D Dies: 1/4" x 2, 5/16" x 18 and 3/8" x 16.
Diestock: 1" O/D.
HSS Die Nuts: 7/16" x 14, 1/2" x 12, 5/8" x 11 and 3/4" x 10.

Range	Number of Pieces	Order Code SHR-086	Price/1 TB
3/16 - 3/4" BSW	28	-9992K	17768.00

BSW
28
PIECES

UNF Threading Set No.10 - 3/4" UNF:

HSSGT Straight Flute Taps:
Taper: No.10 x 32, 1/4" x 28, 5/16" x 24, and 3/8" x 24.
Second: 3/4" x 16, 7/16" x 20, 5/8" x 18 and 1/2" x 20.
Plug: No.10 x 32, 1/4" x 28, 5/16" x 24 and 3/8" x 24.
Bar Type Tap Wrenches: 1/16" - 1/4" and 1/4" - 3/4".
Tapping Drills to Suit: HSS S/S. 4.10, 5.50, 6.90, 8.50, 9.50 and 11.50mm.
HSS 1" O/D Dies: 1/4" x 28, 5/16" x 24 and 3/8" x 24.
Diestock: 1" O/D.
HSS Die Nuts: 7/16" x 20, 1/2" x 20, 5/8" x 18 and 3/4" x 16.

Range	Number of Pieces	Order Code SHR-086	Price/1 TB
10 - 3/4" UNF	28	-9993K	17768.00

UNF
28
PIECES

BSF Threading Set 3/16" - 3/4" BSF:

HSSGT Straight Flute Taps:
Taper: 3/16" x 32, 1/4" x 26, 5/16" x 22 and 3/8" x 20.
Second: 3/4" x 12, 7/16" x 18, 5/8" x 14 and 1/2" x 16.
Plug: 3/16" x 32, 1/4" x 26, 5/16" x 22 and 3/8" x 20.
Bar Type Tap Wrenches: 1/16" - 1/4" and 1/4" - 3/4".
Tapping Drills to Suit: HSS S/S. 4.00, 5.30, 6.80, 8.30, 9.70 and 11.10mm.
HSS 1" O/D Split Dies: 1/4" x 26, 5/16" x 22 and 3/8" x 20.
Diestock: 1" O/D.
HSS Die Nuts: 7/16" x 18, 1/2" x 16, 5/8" x 14 and 3/4" x 12.

Range	Number of Pieces	Order Code SHR-086	Price/1 TB
3/16 - 3/4" BSF	28	-9991K	17768.00

BSF
28
PIECES

BSP(F) Threading Set

HSSGT Straight Flute Taps:
Taper: 1/8" x 28, 1/4" x 19, 3/8" x 19 and 1/2" x 14.
Second: 3/4" x 14.
Plug: 1/8" x 28, 1/4" x 19, 3/8" x 19 and 1/2" x 14.
Outside Diameter HSS Dies BSPF x 1 5/16": 1/8" x 28, 1/4" x 19 and 3/8" x 19.
BSPF HSS Hexagon Die Nuts: 1/2" x 14 and 3/4" x 14.
HSS Straight Shank Jobber Drills: 8.80 and 11.80mm,
Parallel Shank Drills 1/2": 15.25, 19.00 and 24.50mm.
Holders: 1 5/16" outside diameter diestock.
Traditional Tap Wrenches: 1/16" - 1/4" and 1/4" - 3/4".

Range	Number of Pieces	Order Code SHR-086	Price/1 TB
1/16" - 3/4" BSPF	22	-9989K	18025.00

BSP
22
PIECES

SWISS+TECH

High Performance as Standard . . .

...Taking Productivity to New Heights



Cutting Tools For Production Industry
Drills - Milling Cutters - Taps

The tool geometry (with up to 138 parameters) has been developed and optimised during long-term tests in co operation with users for the different sections of structural steel, aluminum casting, machining steel, VA steels, heat-resistant steels and tool steels. Selected hard coatings increase the range of applications. The objective of developing Swiss+Tech's 'Black Ring' Taps was the realisation of narrower tolerances and more efficient cutting times for the thread production.

The unique general purpose properties of these taps guarantee high productivity by reducing the amount of time spent changing taps for different materials and at the same time reduces the number of taps required by the machine shop.

Swiss+Tech 'Black Ring' machine taps with their wide range of applications are the result of years of experience in metal cutting. Responsible for our developments were the following demands from our main customers:

- Increase of a tap's versatility.
- Reducing the confusing type variety.
- Reducing the storage costs for the tools.
- Reducing the tool changing times.

For general tapping applications. For production tapping of specific materials a specialist tap may be more suitable. Manufactured to **DIN 371/376**.

Group	Materials Colour defines similar machineability	Hardness		Tensile Strength N/mm ²	Tapping Speed M/min
		Brinell HB	Rockwell HRC		
1.1	Mild Steel	<130	-	<400	10 - 15
1.2	Case Hardening & Structural Steel	<200	-	<700	10 - 15
1.3	Medium Carbon Steel	<260	<26	<850	5 - 10
1.4	Low Alloy Steel	<260	<26	<850	4 - 8
2.1	Free Machining Stainless	<230	<20	<800	2 - 5
2.2	Medium Strength Austenitic Stainless	<260	<26	<850	2 - 5
7.1	Unalloyed Aluminium Zinc - Magnesium	-	-	<150	15 - 20
7.2	Aluminium Alloy less than 5% Si	-	-	150 - 300	15 - 20
7.3	Aluminium Alloy 5% to 10% Si	<230	<20	<800	5 - 10



Spiral Point/Gun Nose - HSS-E Bright Finish

SPIRAL POINT FOR THROUGH HOLES

HSS-E

For through holes.

Taper lead to **DIN form B**. Tapping tolerance to **6H**.

METRIC



ISO Metric

Size - Pitch (mm)	(d2) Shank Dia.	A/F Square	(l1) Overall Length	(l2) Thread Length	Weight each	Order Code SWT-185	Price/1 TB
M3 x 0.50	3.5	2.7	56	2.5	5g	-8509X	1018.00
M4 x 0.70	4.5	3.4	63	3.3	8g	-8515X	1055.00
M5 x 0.80	6.0	4.9	70	4.2	14g	-8518X	1102.00
M6 x 1.00	6.0	4.9	80	5.0	18g	-8521X	1126.00
M8 x 1.25	8.0	6.2	90	6.8	33g	-8527X	1248.00
M10 x 1.50	10.0	8.0	100	8.5	56g	-8530X	1529.00
M12 x 1.75	9.0	7.0	110	10.2	61g	-8533X	1926.00
M16 x 2.00	12.0	9.0	110	14.0	100g	-8539X	2721.00
M20 x 2.50	16.0	12.0	140	17.5	210g	-8542X	3768.00

Spiral Flute

SPIRAL FLUTE FOR BLIND HOLES

HSS-E

For blind holes.

Taper lead to **DIN form C**.

Tapping tolerance to **6H**.

METRIC



ISO Metric

Size - Pitch (mm)	(d2) Shank Dia.	A/F Square	(l1) Overall Length	(l2) Thread Length	Weight each	Order Code SWT-185	Price/1 TB
M3 x 0.50	3.5	2.7	56	2.5	5g	-8559X	1091.00
M4 x 0.70	4.5	3.4	63	3.3	8g	-8565X	1106.00
M5 x 0.80	6.0	4.9	70	4.2	14g	-8568X	1147.00
M6 x 1.00	6.0	4.9	80	5.0	17g	-8571X	1159.00
M8 x 1.25	8.0	6.2	90	6.8	31g	-8577X	1364.00
M10 x 1.50	10.0	8.0	100	8.5	53g	-8580X	1314.00
M12 x 1.75	9.0	7.0	110	10.2	57g	-8583X	2113.00
M16 x 2.00	12.0	9.0	110	14.0	91g	-8589X	2874.00
M20 x 2.50	16.0	12.0	140	17.5	195g	-8592X	4325.00

Spiral Point Long Series

SPIRAL FLUTE FOR BLIND HOLES

HSS-E

For blind holes.

Taper lead to **DIN 13 form B**

(with gun nose chamber lead 4/5 thread)

Tapping tolerance to **6H**.

Thread angle 60°

METRIC

NEW



ISO Metric

Size - Pitch (mm)	(d2) Shank Dia.	A/F Square	(l1) Overall Length	(l2) Thread Length	Weight each	Order Code SWT-185	Price/1 TB
M6 x 1.00	6.0	4.9	160	17.0	30g	-9806X	1339.00
M8 x 1.25	6.0	4.9	180	20.0	60g	-9808X	2987.00
M10 x 1.50	7.0	5.5	200	22.0	100g	-9810X	3683.00
M12 x 1.75	9.0	7.0	220	24.0	200g	-9812X	4687.00

HSS-E 'Black Ring' M3 - M8 5 Piece Tap Sets

'Black Ring' machine taps for general tapping applications suitable for steels, low alloy steels, stainless steels and non-ferrous materials.

Manufactured to **DIN371/376**.

Tapping tolerance to **6H**.

M3 - M8 Spiral Point/Gun Nose

Spiral Point/Gun Nose - HSS-E Bright Finish

For through holes. Taper lead to **DIN form B**.

M3 - M8 Spiral Flute

Spiral Flute - HSS-E Bright Finish

For blind holes. Taper lead to **DIN form C**.

Contents for each set:

Pitch sizes	Thread length
M3 x 0.5mm	2.5mm
M4 x 0.7mm	3.3mm
M5 x 0.8mm	4.2mm
M6 x 1.0mm	5.0mm
M8 x 1.25mm	6.8mm

5 PIECES



Type	Number of Pieces	Order Code SWT-185	Price/1 TB
Spiral Point	5	-9900X	5330.00
Spiral Flute	5	-9910X	5627.00

SWISS+TECH **HSS 'Yellow Ring' Taps**



Manufactured to **DIN 371/376**

Suitable for the following Material Groups

Group	Materials	Brinell Hardness HB	Tensile Strength N/mm ²	Tapping Speed M/min
1.1	Mild soft steel & free machining non-alloy low carbon steel	up to 130	up to 400	10 - 20
1.2	Non-alloy case hardening, structural & low to medium carbon steel	up to 200	up to 700	10 - 15
1.3	Non-alloy, plain and medium carbon steel and castings	up to 260	up to 850	5 - 10

Spiral Point/Gun Nose - HSS-EV Oxidised Finish
For through holes.
Taper lead to **DIN form B**.
(3.5 x P to 5.5 x P).
Tapping tolerance to **6H**.



ISO Metric Coarse

Size - Pitch (mm)	Overall Length	Thread Length	Shank Dia.	A/F Square	Weight each	Order Code SWT-185	Price/1 TB
M2.0 x 0.40	45.0	8.0	2.8	2.1	4g	-0003Y	1149.00
M3.0 x 0.50	56.0	11.0	3.5	2.7	5g	-0009Y	984.00
M4.0 x 0.70	63.0	13.0	4.5	3.4	8g	-0015Y	984.00
M5.0 x 0.80	70.0	15.0	6.0	4.9	13g	-0018Y	1040.00
M6.0 x 1.00	80.0	17.0	6.0	4.9	17g	-0021Y	1093.00
M8.0 x 1.25	90.0	20.0	8.0	6.0	32g	-0027Y	1203.00
M10.0 x 1.50	100.0	22.0	10.0	8.0	55g	-0030Y	1476.00
M12.0 x 1.75	110.0	24.0	9.0	7.0	61g	-0033Y	1859.00
M16.0 x 2.00	110.0	27.0	12.0	9.0	108g	-0039Y	2624.00

BSP - British Standard Pipe DIN 5156



Size - Pitch	Overall Length	Thread Length	Shank Dia.	A/F Square	Weight each	Order Code SWT-185	Price/1 TB
1/8" x 28	90.0	20.0	7.0	5.5	16g	-0902Y	1804.00
1/4" x 19	100.0	22.0	11.0	9.0	48g	-0904Y	2460.00
3/8" x 19	100.0	22.0	12.0	9.0	69g	-0906Y	2842.00

HSS 'Red Ring' Taps

Manufactured to **DIN 371/376**



Suitable for the following Material Groups

Group	Materials	Brinell Hardness HB	Tensile Strength N/mm ²	Tapping Speed M/min
1.4	Generally low to medium alloy steel and castings	up to 260	up to 850	5 - 10
1.5	Medium to high alloy steel tool steel and steel castings	up to 340	up to 1200	4 - 8

Spiral Point/Gun Nose - HSS-Co Bright Finish
For through holes.
Taper lead to **DIN form B**.
(3.5 x P to 5.5 x P).
Tapping tolerance to **6HX**.



ISO Metric Coarse

Size - Pitch (mm)	Overall Length	Thread Length	Shank Dia.	A/F Square	Weight each	Order Code SWT-185	Price/1 TB
M2.0 x 0.40	45.0	8.0	2.8	2.1	4g	-1003R	1486.00
M3.0 x 0.50	56.0	11.0	3.5	2.7	5g	-1009R	984.00
M4.0 x 0.70	63.0	13.0	4.5	3.4	8g	-1015R	984.00
M5.0 x 0.80	70.0	15.0	6.0	4.9	13g	-1018R	984.00
M6.0 x 1.00	80.0	17.0	6.0	4.9	17g	-1021R	1093.00
M8.0 x 1.25	90.0	20.0	8.0	6.2	32g	-1027R	1203.00
M10.0 x 1.50	100.0	22.0	10.0	8.0	58g	-1030R	1476.00
M12.0 x 1.75	110.0	24.0	9.0	7.0	61g	-1033R	1859.00
M16.0 x 2.00	110.0	27.0	12.0	9.0	108g	-1039R	2936.00

Spiral Flute - HSS-EV Oxidised Finish

For blind holes.
Taper lead to **DIN form C** (3 x P).
Tapping tolerance:
Spiral flute to **6H**.

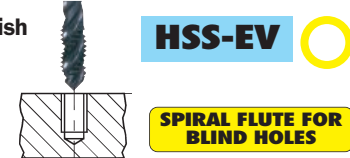

ISO Metric Coarse

Helix angle 40°. Tapping depth **2.5 x D**.

Size - Pitch (mm)	Overall Length	Thread Length	Shank Dia.	A/F Square	Weight each	Order Code SWT-185	Price/1 TB
M2.0 x 0.40	45.0	8.0	2.8	2.1	5g	-0503Y	1367.00
M3.0 x 0.50	56.0	6.0	3.5	2.7	5g	-0509Y	1203.00
M4.0 x 0.70	63.0	7.0	4.5	3.4	8g	-0515Y	1093.00
M5.0 x 0.80	70.0	8.0	6.0	4.9	13g	-0518Y	1149.00
M6.0 x 1.00	80.0	10.0	6.0	4.9	16g	-0521Y	1093.00
M8.0 x 1.25	90.0	13.0	8.0	6.2	30g	-0527Y	1367.00
M10.0 x 1.50	100.0	15.0	10.0	8.0	45g	-0530Y	1749.00
M12.0 x 1.75	110.0	18.0	9.0	7.0	56g	-0533Y	2077.00
M16.0 x 2.00	110.0	20.0	12.0	9.0	95g	-0539Y	2842.00

BSP - British Standard Pipe Bright Finish DIN 5156



Size - Pitch	Overall Length	Thread Length	Shank Dia.	A/F Square	Weight each	Order Code SWT-185	Price/1 TB
1/8" x 28	90.0	20.0	7.0	5.5	16g	-0932Y	1914.00
1/4" x 19	100.0	22.0	11.0	9.0	48g	-0934Y	2678.00
3/8" x 19	100.0	22.0	12.0	9.0	69g	-0936Y	3225.00
1/2" x 14	125.0	25.0	16.0	12.0	152g	-0938Y	4099.00



Spiral Flute - HSS-EV Oxidised Finish

For blind holes.
Taper lead to **DIN form C** (3 x P).
Tapping tolerance:
spiral flute to **6H**.

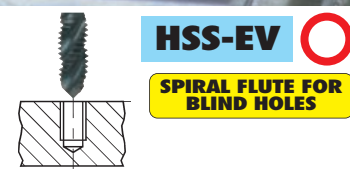

ISO Metric Coarse

Helix angle 40°. Tapping depth **2.5 x D**.

Size - Pitch (mm)	Overall Length	Thread Length	Shank Dia.	A/F Square	Weight each	Order Code SWT-185	Price/1 TB
M2.0 x 0.40	45.0	3.0	2.8	2.1	5g	-1503R	2070.00
M3.0 x 0.50	56.0	6.0	3.5	2.7	5g	-1509R	1203.00
M4.0 x 0.70	63.0	7.0	4.5	3.4	8g	-1515R	1040.00
M5.0 x 0.80	70.0	8.0	6.0	4.9	13g	-1518R	1149.00
M6.0 x 1.00	80.0	10.0	6.0	4.9	16g	-1521R	1093.00
M8.0 x 1.25	90.0	13.0	8.0	6.2	30g	-1527R	1367.00
M10.0 x 1.50	100.0	15.0	10.0	8.0	45g	-1530R	1749.00
M12.0 x 1.75	110.0	18.0	9.0	7.0	56g	-1533R	2077.00
M16.0 x 2.00	110.0	20.0	12.0	9.0	95g	-1539R	2788.00

PRODUCTS ARE ONLY AVAILABLE VIA YOUR DISTRIBUTOR

CUTTING TOOLS

GROUP 085 PRODUCTION TAPS

SWISS+TECH HSS 'Blue Ring' Taps

Manufactured to **DIN 371/376**

Suitable for the following Material Groups

Group	Materials	Brinell Hardness HB	Tensile Strength N/mm ²	Tapping Speed M/min
2.1	Soft and generally easy to machine ferritic & martensitic stainless steel and castings	up to 230	up to 800	4 - 6
2.2	Medium strength & reasonable to machine austenitic stainless steel and castings	up to 290	up to 1000	4 - 6
2.3	Hard & generally difficult to machine ferritic & austenitic stainless steel & castings	up to 340	up to 1200	3 - 6

Note: Fluteless taps may also be used on stainless steel. See 'Green Ring' **FLUTELESS** on page TB.

Spiral Point/Gun Nose - HSS-EV Oxidised Finish

For through holes. Taper lead to **DIN form B** (3.5 x P to 5.5 x P). Tapping tolerance to **6HX**.

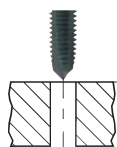

HSS-EV
SPIRAL POINT FOR THROUGH HOLES



ISO Metric Coarse

Size - Pitch (mm)	Overall Length	Thread Length	Shank Dia.	A/F Square	Weight each	Order Code SWT-185	Price/1 TB
M2.0 x 0.40	45.0	8.0	2.8	2.1	4g	-2003B	1149.00
M3.0 x 0.50	56.0	11.0	3.5	2.7	5g	-2009B	984.00
M4.0 x 0.70	63.0	13.0	4.5	3.4	8g	-2015B	984.00
M5.0 x 0.80	70.0	15.0	6.0	4.9	13g	-2018B	1040.00
M6.0 x 1.00	80.0	17.0	6.0	4.9	17g	-2021B	1149.00
M8.0 x 1.25	90.0	20.0	8.0	6.0	32g	-2027B	1203.00
M10.0 x 1.50	100.0	22.0	10.0	8.0	55g	-2030B	1476.00
M12.0 x 1.75	110.0	24.0	9.0	7.0	61g	-2033B	1859.00
M16.0 x 2.00	110.0	27.0	12.0	9.0	108g	-2039B	2624.00

HSS 'White Ring' Taps

Manufactured to **DIN 371/376**

Suitable for the following Material Groups

Group	Materials	Brinell Hardness HB	Tensile Strength N/mm ²	Tapping Speed M/min
3.1	Grey cast iron Hardness soft to medium	up to 130	up to 400	8 - 12
3.2	Grey cast iron Hardness medium to hard	up to 200	up to 700	4 - 6

Straight Flute - HSS-EV Nitride Finish

For through holes. Taper lead to **DIN form D** (taper) (3.5 x P to 5 x P). Tapping tolerance to **6HX**.

STRAIGHT FLUTE FOR THROUGH HOLES

METRIC COARSE



ISO Metric Coarse

Size - Pitch (mm)	Overall Length	Thread Length	Shank Dia.	A/F Square	Weight each	Order Code SWT-185	Price/1 TB
M2.0 x 0.40	45.0	8.0	2.8	2.1	14g	-3503W	2070.00
M3.0 x 0.50	56.0	11.0	3.5	2.7	5g	-3509W	1751.00
M4.0 x 0.70	63.0	13.0	4.5	3.4	8g	-3515W	1858.00
M5.0 x 0.80	70.0	16.0	6.0	4.9	13g	-3518W	1964.00
M6.0 x 1.00	80.0	17.0	6.0	4.9	17g	-3521W	2070.00
M8.0 x 1.25	90.0	22.0	8.0	6.2	32g	-3527W	2228.00
M10.0 x 1.50	100.0	24.0	10.0	8.0	55g	-3530W	2547.00
M12.0 x 1.75	110.0	29.0	9.0	7.0	61g	-3533W	2918.00

Spiral Flute (BLT) - HSS-EV Oxidised Finish

For deep blind holes. Taper lead to **DIN form C** (2 x P to 3 x P). Tapping tolerance to **6H**.



HSS-EV

SPIRAL FLUTE FOR BLIND HOLES

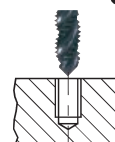

'Biteless Taper' ISO Metric Coarse

Helix angle 45°

Size - Pitch (mm)	Overall Length	Thread Length	Shank Dia.	A/F Square	Weight each	Order Code SWT-185	Price/1 TB
M2.0 x 0.40	45.0	8.0	2.8	2.1	5g	-2503B	2405.00
M3.0 x 0.50	56.0	6.0	3.5	2.7	5g	-2509B	1040.00
M4.0 x 0.70	63.0	7.0	4.5	3.4	8g	-2515B	1040.00
M5.0 x 0.80	70.0	8.0	6.0	4.9	13g	-2518B	1093.00
M6.0 x 1.00	80.0	11.0	6.0	4.9	16g	-2521B	1093.00
M8.0 x 1.25	90.0	13.0	8.0	6.2	30g	-2527B	1313.00
M10.0 x 1.50	100.0	15.0	10.0	8.0	45g	-2530B	1258.00
M12.0 x 1.75	110.0	18.0	9.0	7.0	56g	-2533B	2023.00
M16.0 x 2.00	110.0	20.0	12.0	9.0	95g	-2539B	2788.00

Spiral Flute (BLF) - HSS-EV Oxidised Finish

For shorter blind holes. Taper lead to **DIN form C** (3 x P). Tapping tolerance to **6H**.

'Biteless Flat' ISO Metric Coarse

Helix angle 45°

Size - Pitch (mm)	Overall Length	Thread Length	Shank Dia.	A/F Square	Weight each	Order Code SWT-185	Price/1 TB
M3.0 x 0.50	56.0	6.0	3.5	2.7	5g	-3009B	2121.00
M4.0 x 0.70	63.0	7.0	4.5	3.4	8g	-3015B	2228.00
M5.0 x 0.80	70.0	8.0	6.0	4.9	13g	-3018B	2334.00
M6.0 x 1.00	80.0	11.0	6.0	4.9	16g	-3021B	2441.00
M8.0 x 1.25	90.0	13.0	8.0	6.2	30g	-3027B	2547.00
M10.0 x 1.50	100.0	15.0	10.0	8.0	45g	-3030B	2918.00
M12.0 x 1.75	110.0	18.0	9.0	7.0	56g	-3033B	3025.00
M16.0 x 2.00	110.0	20.0	12.0	9.0	95g	-3039B	3449.00

HSS-EV

Group	Materials	Brinell Hardness HB	Tensile Strength N/mm ²	Tapping Speed M/min
3.3	Malleable and nodular irons Hardness soft to medium	up to 220	up to 850	4 - 6
3.4	Malleable and nodular irons Hardness medium to hard	up to 300	up to 700	4 - 6

Straight Flute - HSS-EV Nitride Finish

For blind holes. Plug/bottoming lead to **DIN form C** (2 x P to 3 x P). Tapping tolerance to **6HX**.

STRAIGHT FLUTE FOR BLIND HOLES

METRIC COARSE



ISO Metric Coarse

Size - Pitch (mm)	Overall Length	Thread Length	Shank Dia.	A/F Square	Weight each	Order Code SWT-185	Price/1 TB
M2.0 x 0.40	45.0	8.0	2.8	2.1	4g	-4003W	2070.00
M2.5 x 0.45	50.0	9.0	2.8	2.1	4g	-4006W	1645.00
M3.0 x 0.50	56.0	11.0	3.5	2.7	5g	-4009W	1751.00
M4.0 x 0.70	63.0	13.0	4.5	3.4	8g	-4015W	1858.00
M5.0 x 0.80	70.0	16.0	6.0	4.9	13g	-4018W	1964.00
M6.0 x 1.00	80.0	19.0	6.0	4.9	17g	-4021W	2070.00
M8.0 x 1.25	90.0	22.0	8.0	6.2	32g	-4027W	2228.00
M10.0 x 1.50	100.0	24.0	10.0	8.0	58g	-4030W	2653.00
M12.0 x 1.75	110.0	29.0	9.0	7.0	61g	-4033W	2918.00
M16.0 x 2.00	110.0	32.0	12.0	9.0	108g	-4039W	3250.00

SWISS+TECH **HSS 'Purple Ring' Taps**



Suitable for the following Material Groups

Group	Materials	Brinell Hardness HB	Tensile Strength N/mm ²	Tapping Speed M/min
4.1	Titanium alloy (also pure nickel)	-		3 - 9

Right Hand Cutting - Left Hand Spiral Flute - HSS-PM Nitride Finish
For through holes. Left hand spiral. Taper lead to **DIN form D** (3.5 x P to 5 x P). Tapping tolerance to **6HX**.

LEFT HAND SPIRAL FLUTE FOR THROUGH HOLES

METRIC COARSE



ISO Metric Coarse	Helix angle 15°.	Size - Pitch (mm)	Overall Length	Thread Length	Shank Dia.	A/F Square	Weight each	Order Code SWT-185	Price/1 TB
M3.0 x 0.50	56.0	11.0	3.5	2.7	5g	-4509P	1751.00		
M4.0 x 0.70	63.0	13.0	4.5	3.4	8g	-4515P	1858.00		
M5.0 x 0.80	70.0	16.0	6.0	4.9	14g	-4518P	1964.00		
M6.0 x 1.00	80.0	19.0	6.0	4.9	17g	-4521P	2070.00		
M8.0 x 1.25	90.0	22.0	8.0	6.2	32g	-4527P	2228.00		
M10.0 x 1.50	100.0	24.0	10.0	8.0	55g	-4530P	2441.00		
M12.0 x 1.75	110.0	29.0	9.0	7.0	63g	-4533P	3289.00		
M16.0 x 2.00	110.0	32.0	12.0	9.0	111g	-4539P	4350.00		

HSS 'Orange Ring' Taps

Suitable for the following Material Groups

Group	Materials	Brinell Hardness HB	Tensile Strength N/mm ²	Tapping Speed M/min
4.3	Titanium alloys of a hard and very hard to machine nature	-	up to 1250	3 - 6
5.1	Heat resistant super alloys including iron based high temperature alloys	-	up to 500	6 - 6

Spiral Point/Gun Nose - HSS-PM Nitride & Oxide Finish
For through holes. Taper lead to **DIN form B** (3.5 x P to 5.5 x P). Tapping tolerance to **6HX**.

SPIRAL POINT FOR THROUGH HOLES

METRIC COARSE



ISO Metric Coarse	Size - Pitch (mm)	Overall Length	Thread Length	Shank Dia.	A/F Square	Weight each	Order Code SWT-185	Price/1 TB
M3.0 x 0.50	56.0	11.0	3.5	2.7	5g	-5509N	1586.00	
M4.0 x 0.70	63.0	13.0	4.5	3.4	8g	-5515N	1586.00	
M5.0 x 0.80	70.0	16.0	6.0	4.9	13g	-5518N	1695.00	
M6.0 x 1.00	80.0	19.0	6.0	4.9	17g	-5521N	1695.00	
M8.0 x 1.25	90.0	22.0	8.0	6.2	32g	-5527N	2023.00	
M10.0 x 1.50	100.0	24.0	10.0	8.0	55g	-5530N	2624.00	
M12.0 x 1.75	110.0	29.0	9.0	7.0	61g	-5533N	3116.00	
M16.0 x 2.00	110.0	32.0	12.0	9.0	108g	-5539N	4584.00	

HSS-PM

Group	Materials	Brinell Hardness HB	Tensile Strength N/mm ²	Tapping Speed M/min
4.2	Titanium alloy medium and hard to machine	-	up to 900	6 - 9
4.3	Titanium alloys of a hard and very hard to machine nature	-	up to 1200	6 - 9

Spiral Flute - HSS-PM Nitride Finish
For blind holes. Taper lead to **DIN form B** (3 x P). Tapping tolerance to **6HX**.

SPIRAL FLUTE FOR BLIND HOLES

METRIC COARSE



ISO Metric Coarse	Helix angle 15°.	Size - Pitch (mm)	Overall Length	Thread Length	Shank Dia.	A/F Square	Weight each	Order Code SWT-185	Price/1 TB
M3.0 x 0.50	56.0	5.0	3.5	2.7	5g	-5009P	1422.00		
M4.0 x 0.70	63.0	7.0	4.5	3.4	8g	-5015P	1592.00		
M5.0 x 0.80	70.0	9.0	6.0	4.9	14g	-5018P	1698.00		
M6.0 x 1.00	80.0	11.0	6.0	4.9	17g	-5021P	1804.00		
M8.0 x 1.25	90.0	12.0	8.0	6.2	32g	-5027P	1910.00		
M10.0 x 1.50	100.0	13.0	10.0	8.0	55g	-5030P	2016.00		
M12.0 x 1.75	110.0	15.0	9.0	7.0	63g	-5033P	2678.00		

HSS-PM

Group	Materials	Brinell Hardness HB	Tensile Strength N/mm ²	Tapping Speed M/min
5.2	Heat resistant super alloys, cobalt or nickel based medium to hard to machine	-	up to 900	3 - 6
5.3	Heat resistant super alloys, cobalt or nickel based hard to very hard to machine	-	up to 1200	3 - 6

Spiral Flute - HSS-PM Nitride & Oxide Finish
For blind holes. Taper lead to **DIN form C**. This tap has the special chamfer lead of (3 x P). Tapping tolerance: spiral flute to **6H**.

SPIRAL FLUTE FOR BLIND HOLES

METRIC COARSE



ISO Metric Coarse	Helix angle 40°.	Size - Pitch (mm)	Overall Length	Thread Length	Shank Dia.	A/F Square	Weight each	Order Code SWT-185	Price/1 TB
M3.0 x 0.50	56.0	5.0	3.5	2.7	5g	-6009N	1592.00		
M4.0 x 0.70	63.0	7.0	4.5	3.4	9g	-6015N	1476.00		
M5.0 x 0.80	70.0	9.0	6.0	4.9	13g	-6018N	1531.00		
M6.0 x 1.00	80.0	11.0	6.0	4.9	16g	-6021N	1531.00		
M8.0 x 1.25	90.0	12.0	8.0	6.2	30g	-6027N	1859.00		
M10.0 x 1.50	100.0	13.0	10.0	8.0	51g	-6030N	2186.00		
M12.0 x 1.75	110.0	15.0	9.0	7.0	56g	-6033N	2788.00		
M14.0 x 2.00	110.0	18.0	11.0	9.0	63g	-6036N	3826.00		
M16.0 x 2.00	110.0	18.0	12.0	9.0	95g	-6039N	3935.00		

PRODUCTS ARE ONLY AVAILABLE VIA YOUR DISTRIBUTOR

CUTTING TOOLS

GROUP 085 PRODUCTION TAPS

SWISS+TECH HSS 'Green Ring' Taps

Manufactured to **DIN 371/376**

Suitable for the following Material Groups



Group	Materials	Brinell Hardness HB	Tensile Strength N/mm ²	Tapping Speed M/min
7.1	Unalloyed aluminium, magnesium and zinc	-	up to 150	20 - 30
7.2	Aluminium alloy less than 5% silicon magnesium & zinc alloys (long chip)	-	up to 1200	20 - 30

Spiral Point/Gun Nose - HSS-EV Nitride Finish
For through holes. Taper lead to **DIN form B** (3.5 x P to 5.5 x P).
Tapping tolerance to **6HX**.

SPIRAL POINT FOR THROUGH HOLES

METRIC COARSE



ISO Metric Coarse

Size - Pitch (mm)	Overall Length	Thread Length	Shank Dia.	A/F Square	Weight each	Order Code SWT-185	Price/1 TB
M2.0 x 0.40	45.0	8.0	2.8	2.1	4g	-6503G	1133.00
M3.0 x 0.50	56.0	11.0	3.5	2.7	5g	-6509G	773.00
M4.0 x 0.70	63.0	13.0	4.5	3.4	8g	-6515G	773.00
M5.0 x 0.80	70.0	16.0	6.0	4.9	13g	-6518G	821.00
M6.0 x 1.00	80.0	19.0	6.0	4.9	17g	-6521G	821.00
M8.0 x 1.25	90.0	22.0	8.0	6.2	32g	-6527G	1133.00
M10.0 x 1.50	100.0	24.0	10.0	8.0	58g	-6530G	1288.00
M12.0 x 1.75	110.0	29.0	9.0	7.0	61g	-6533G	2228.00

HSS 'Green Ring' Fluteless Taps

Lubrication grooves are a feature of all taps of M3.0 and over. Manufactured to **DIN 371/376**.



Suitable for the following Material Groups

Group	Materials	Brinell Hardness HB	Tensile Strength N/mm ²	Tapping Speed M/min
6.1	Copper	-	up to 500	8 - 12
6.2	Brass (alpha - long chip)	-	up to 800	15 - 20

Fluteless - HSS-EV Bright Finish

For through and blind holes.
Taper lead to **DIN form B** (3.5 x P to 5.5 x P). Tapping tolerance to **6H**.

FLUTELESS FOR THROUGH AND BLIND HOLES

METRIC COARSE



ISO Metric Coarse

Size - Pitch (mm)	Overall Length	Thread Length	Shank Dia.	A/F Square	Weight each	Order Code SWT-185	Price/1 TB
M2.0 x 0.40	45.0	8.0	2.8	2.1	4g	-7503G	1380.00
M3.0 x 0.50	56.0	11.0	3.5	2.7	5g	-7509G	1625.00
M4.0 x 0.70	63.0	13.0	4.5	3.4	8g	-7515G	1799.00
M5.0 x 0.80	70.0	15.0	6.0	4.9	13g	-7518G	1066.00
M6.0 x 1.00	80.0	17.0	6.0	4.9	17g	-7521G	1085.00
M8.0 x 1.25	90.0	20.0	8.0	6.2	32g	-7527G	1361.00
M10.0 x 1.50	100.0	22.0	10.0	8.0	58g	-7530G	3395.00
M12.0 x 1.75	110.0	24.0	9.0	7.0	61g	-7533G	3811.00

Group	Materials	Brinell Hardness HB	Tensile Strength N/mm ²	Tapping Speed M/min
7.3	Aluminium alloy 5% to 10% silicon	-	up to 500	15 - 20
7.4	Aluminium alloy 5% to 10% silicon	-	up to 500	15 - 20

Spiral Flute - HSS-EV Nitride Finish
For blind holes. Taper lead to **DIN form C** (2 x P to 3 x P). Tapping tolerance to **6H**.

SPIRAL FLUTE FOR BLIND HOLES

METRIC COARSE



ISO Metric Coarse Helix angle 45°. Tapping depth 2.5 x D.

Size - Pitch (mm)	Overall Length	Thread Length	Shank Dia.	A/F Square	Weight each	Order Code SWT-185	Price/1 TB
M2.0 x 0.40	45.0	8.0	2.8	2.1	5g	-7003G	1133.00
M2.5 x 0.45	50.0	9.0	2.8	2.1	5g	-7006G	1040.00
M3.0 x 0.50	56.0	11.0	3.5	2.7	5g	-7009G	821.00
M3.5 x 0.60	56.0	13.0	4.0	3.0	6g	-7012G	875.00
M4.0 x 0.70	63.0	13.0	4.5	3.4	8g	-7015G	821.00
M5.0 x 0.80	70.0	16.0	6.0	4.9	13g	-7018G	875.00
M6.0 x 1.00	80.0	19.0	6.0	4.9	16g	-7021G	931.00
M8.0 x 1.25	90.0	22.0	8.0	6.2	30g	-7027G	1110.00
M10.0 x 1.50	100.0	24.0	10.0	8.0	45g	-7030G	1298.00
M12.0 x 1.75	110.0	29.0	9.0	7.0	56g	-7033G	1688.00

Fluteless - HSS-EV (TiN Coated)

For through and blind holes.
Taper lead to **DIN form B** (3.5 x P to 5.5 x P). Tapping tolerance to **6H**.

FLUTELESS FOR THROUGH AND BLIND HOLES

METRIC COARSE



ISO Metric Coarse

Size - Pitch (mm)	Overall Length	Thread Length	Shank Dia.	A/F Square	Weight each	Order Code SWT-185	Price/1 TB
M2.0 x 0.40	45.0	8.0	2.8	2.1	4g	-8003G	3193.00
M3.0 x 0.50	56.0	11.0	3.5	2.7	5g	-8009G	1431.00
M4.0 x 0.70	63.0	13.0	4.5	3.4	8g	-8015G	1571.00
M5.0 x 0.80	70.0	15.0	6.0	4.9	13g	-8018G	2053.00
M6.0 x 1.00	80.0	17.0	6.0	4.9	17g	-8021G	2073.00
M8.0 x 1.25	90.0	20.0	8.0	6.2	32g	-8027G	2733.00
M10.0 x 1.50	100.0	22.0	10.0	8.0	58g	-8030G	3250.00
M12.0 x 1.75	110.0	24.0	9.0	7.0	61g	-8033G	4462.00



Brazed Tip Turning & Boring Tools

Manufactured in three standard grades (all sizes are nominal).
Manufactured to **ISO DIN BHMA Standards**.

P40 **P40:** Roughing to heavy roughing of steel and steel castings using heavy feeds and low to medium cutting speeds. Also used under unfavourable conditions, particularly where intermittent cutting is involved. This grade is also suitable for planing operations and for machining manganese steel.

P30 **P30:** Carbide tipped tools are suitable for heavy duty turning and boring on all classes of steel. Suitable also for interrupted cutting and machining at low speeds and heavy feeds.

K20 **K20:** General purpose tools for most applications. Ideal for machining cast iron, non-ferrous metals, bakelite etc. Combines wear resistance with toughness when rough turning at moderate cutting speeds. Suitable for high feed rates.

CUTTING TOOLS

Straight Round Nosed Turning Tools



Tool No.	Cut	Shank Height x Width	Weight each	Order Code KEN-100			Price/1 TB
				P40	P30	K20	
010	N	3/8" x 3/8"	160g	-	-0100K	-0110K	1120.00
012	N	1/2" x 1/2"	190g	-	-0140K	-0150K	1130.00
016	N	5/8" x 5/8"	240g	-	-0190K	-0200K	1445.00
020	N	3/4" x 3/4"	410g	-	-0230K	-0240K	1784.00
024	N	1" x 3/4"	520g	-	-0270K	-	2085.00
026	N	1" x 1"	760g	-	-0310K	-	2514.00

Cranked Round Nosed Turning Tools

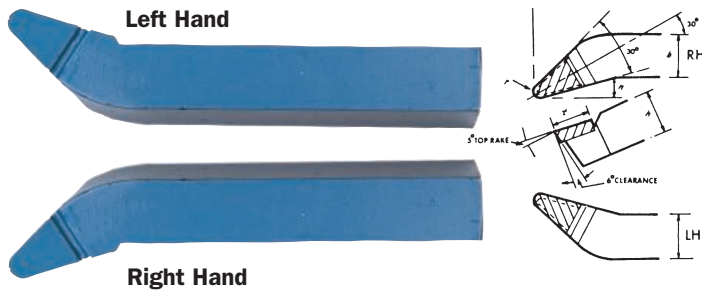

Tool No.	Cut	Shank Height x Width	Weight each	Order Code KEN-100			Price/1 TB
				P40	P30	K20	
12	RH	1/2" x 1/2"	110g	-	-0510K	-0520K	1583.00
13	LH	1/2" x 1/2"	110g	-	-0530K	-0540K	1583.00
16	RH	5/8" x 5/8"	240g	-	-0590K	-0600K	1659.00
17	LH	5/8" x 5/8"	240g	-	-0610K	-	1659.00
20	RH	3/4" x 3/4"	410g	-	-0690K	-0700K	2085.00
21	LH	3/4" x 3/4"	410g	-	-0710K	-0720K	2085.00
26	RH	1" x 1"	720g	-	-0820K	-	2453.00
27	LH	1" x 1"	720g	-	-0840K	-	2453.00

Light Turning & Boring Tools



Tool No.	Cut	Shank Height x Width	Weight each	Order Code KEN-100			Price/1 TB
				P40	P30	K20	
40	N	3/8" x 3/8"	70g	-	-1000K	-	1207.00
44	N	1/2" x 1/2"	120g	-	-1060K	-1070K	1394.00
60	N	3/4" x 3/4"	430g	-	-1660K	-	1897.00

Bar Turning Tools

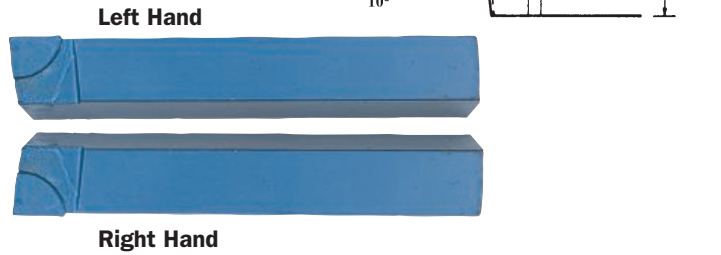
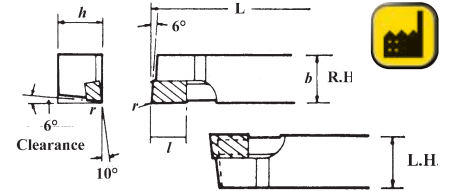

Tool No.	Cut	Shank Height x Width	Weight each	Order Code KEN-100			Price/1 TB
				P40	P30	K20	
100	RH	3/8" x 3/8"	70g	-	-2010K	-	1081.00
101	LH	3/8" x 3/8"	70g	-	-2040K	-	1081.00
102	RH	1/2" x 1/2"	120g	-2055K	-2060K	-2080K	1207.00
103	LH	1/2" x 1/2"	120g	-	-2100K	-2110K	1207.00
106	RH	5/8" x 5/8"	260g	-	-2180K	-	1533.00
110	RH	3/4" x 3/4"	440g	-	-2280K	-2290K	1735.00
111	LH	3/4" x 3/4"	440g	-	-2300K	-	1735.00

Bar & Knee Turning Tools

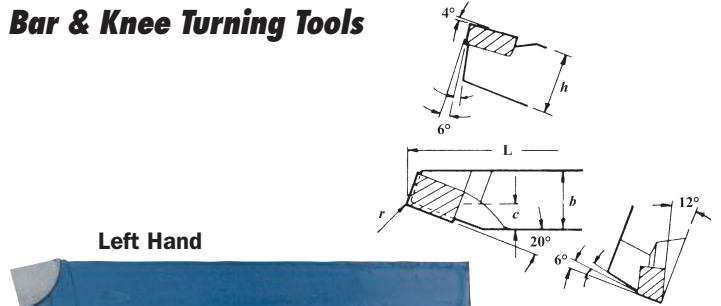

Tool No.	Cut	Shank Height x Width	Weight each	Order Code KEN-100			Price/1 TB
				P40	P30	K20	
132	RH	1/2" x 1/2"	120g	-	-2550K	-	1659.00
140	RH	3/4" x 3/4"	430g	-	-2610K	-	1772.00
141	LH	3/4" x 3/4"	430g	-	-2630K	-	1897.00

Cranked Turning Tools

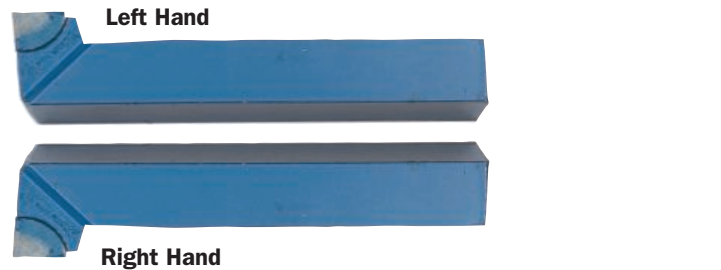
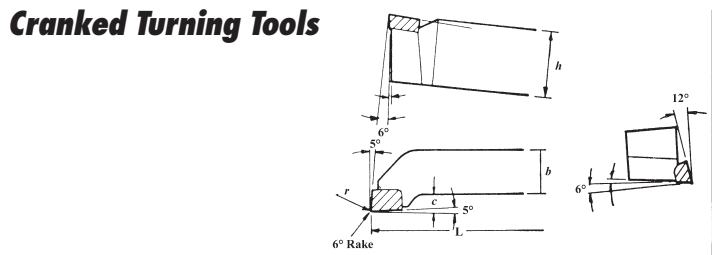

Tool No.	Cut	Shank Height x Width	Weight each	Order Code KEN-100			Price/1 TB
				P40	P30	K20	
160	RH	3/8" x 3/8"	70g	-	-2780K	-2790K	1332.00
161	LH	3/8" x 3/8"	70g	-	-2800K	-	1332.00
162	RH	1/2" x 1/2"	130g	-	-2830K	-2860K	1362.00
163	LH	1/2" x 1/2"	130g	-	-2870K	-2880K	1394.00
166	RH	5/8" x 5/8"	270g	-	-2940K	-2960K	1659.00
167	LH	5/8" x 5/8"	270g	-	-	-2990K	1772.00
170	RH	3/4" x 3/4"	460g	-	-3040K	-3070K	2023.00
171	LH	3/4" x 3/4"	460g	-	-3080K	-3090K	2023.00



Brazed Tip Cranked Turning & Facing Tools

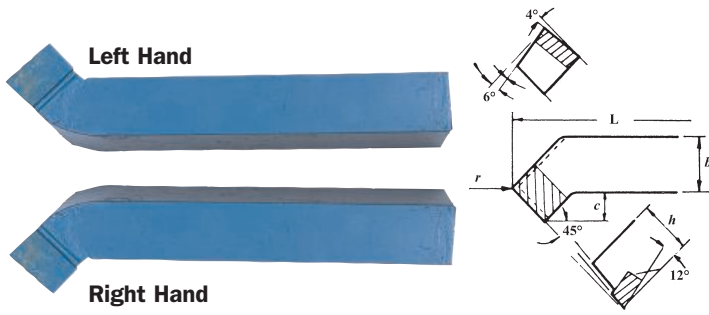

Tool No.	Cut	Shank Height x Width	Weight each	Order Code KEN-100			Price/1 TB
				P40	P30	K20	
192	RH	1/2" x 1/2"	110g	-	-3410K	-3420K	1458.00
196	RH	5/8" x 5/8"	260g	-3490K	-3500K	-	1709.00
197	LH	5/8" x 5/8"	260g	-	-3520K	-	1709.00
200	RH	3/4" x 3/4"	430g	-3680K	-3690K	-3710K	2122.00
201	LH	3/4" x 3/4"	430g	-	-3720K	-	2122.00
206	RH	1" x 1"	790g	-	-	-3850K	2965.00
207	LH	1" x 1"	790g	-3855K	-	-	2965.00

Straight Recessing Tools

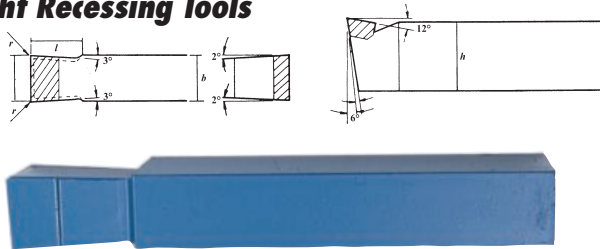

Tool No.	Cut	Shank Height x Width	Weight each	Order Code KEN-100			Price/1 TB
				P40	P30	K20	
230	N	3/8" x 3/8"	64g	-	-4370K	-	1207.00
232	N	1/2" x 1/2"	120g	-	-4460K	-	1489.00
236	N	5/8" x 5/8"	250g	-	-4620K	-	1709.00

Parting Off Tools

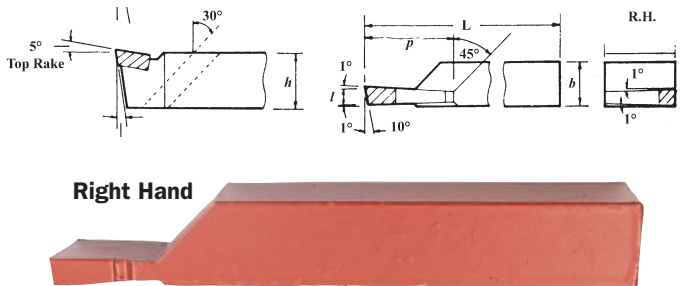

Tool No.	Tip	Shank Height x Width	Weight each	Order Code KEN-100			Price/1 TB
				P40	P30	K20	
260	3/32"	5/8" x 3/8"	120g	-5200K	-5210K	-5220K	2274.00
262	1/8"	3/4" x 1/2"	220g	-5260K	-5270K	-5280K	2274.00
264	3/16"	1" x 5/8"	390g	-5320K	-5330K	-5350K	2306.00
265	1/4"	1" x 3/4"	480g	-5420K	-5430K	-	2306.00
270	3/32"	5/8" x 3/8"	110g	-	-5610K	-	1709.00
272	1/8"	3/4" x 1/2"	220g	-	-5690K	-5710K	1552.00
274	3/16"	1" x 5/8"	390g	-	-5750K	-5770K	2237.00
275	1/4"	1" x 3/4"	460g	-5810K	-5820K	-5840K	2349.00
276	5/16"	1 1/4" x 3/4"	700g	-	-5880K	-5900K	3343.00

Square Shank Boring Tools Held at 90° in Bar



Tool No.	Cut	Shank H W	Weight each	Order Code KEN-100			Price/1 TB
				P40	P30	K20	
280	RH	1/4" x 1/4"	11g	-	-6180K	-	1231.00
288	RH	1/2" x 1/2"	109g	-	-6340K	-	1822.00

Square Shank Boring Tools Held at 80° in Bar

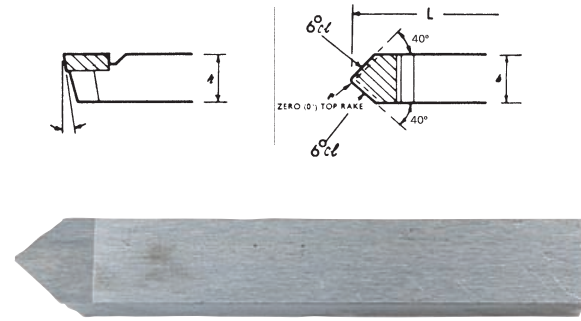

Tool No.	Cut	Shank H W	Weight each	Order Code KEN-100			Price/1 TB
				P40	P30	K20	
300	N	1/4" x 1/4"	11g	-	-6580K	-	1394.00
308	N	3/8" x 3/8"	16g	-	-6750K	-	1583.00
316	N	1/2" x 1/2"	109g	-	-6920K	-	1961.00

Light Duty Round Shank Boring Tools Used at 45° in Bar

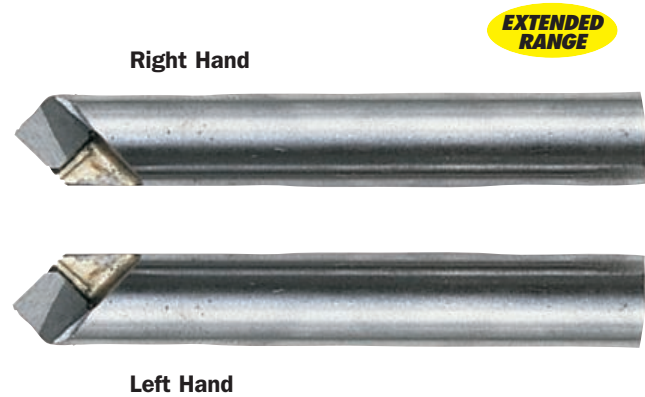

Tool No.	Cut	Shank Dia. x Length	Weight each	Order Code KEN-100			Price/1 TB
				P40	P30	K20	
375	LH	5/16" x 1 1/2"	13g	-	-8110K	-	1313.00
376	RH	3/8" x 2 1/2"	30g	-	-8130K	-	1422.00
377	LH	3/8" x 2 1/2"	30g	-	-8150K	-8160K	1422.00
380	RH	1/2" x 5"	65g	-	-8220K	-	1531.00

Cranked Knife Turning Tools

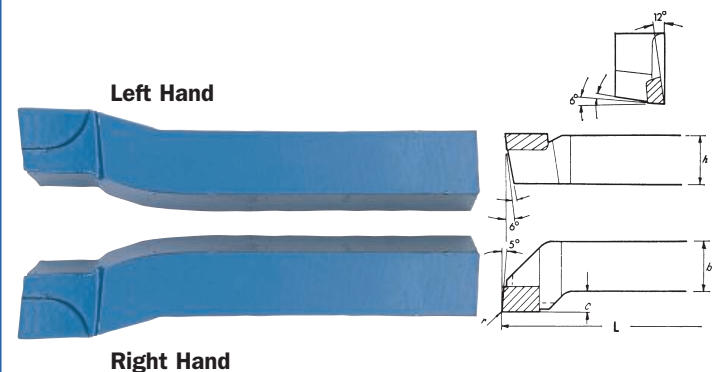

Tool No.	Cut	Shank Height x Width	Weight each	Order Code KEN-100			Price/1 TB
				P40	P30	K20	
2130	RH	3/8" x 3/8"	70g	-	-8970K	-	1313.00
2132	RH	1/2" x 1/2"	120g	-	-9010K	-9020K	1458.00
2133	LH	1/2" x 1/2"	120g	-	-9030K	-	1458.00
2136	RH	5/8" x 5/8"	260g	-	-9230K	-9250K	1740.00
2137	LH	5/8" x 5/8"	260g	-	-9260K	-	1740.00
2140	RH	3/4" x 3/4"	430g	-9380K	-9390K	-9400K	2137.00
2141	LH	3/4" x 3/4"	430g	-	-9420K	-	2137.00
2146	RH	1" x 1"	800g	-	-9670K	-	3405.00

External Toolholders - ISO Designation

1 Clamping System

C	Clamp
D	"One-Double"
M	Clamp & Pin
P	Lever
S	Screw

3 Lead Angle

B 75°	C 90°	D 45°	F 90°
G 90°	J 93°	K 75°	L 95°
N 63°	S 45°	T 60°	U 93°
V 72½°	W 60°		

5 Hand

R	
L	
N	

9 Cutting Edge Length

Expressed in millimetres	
C, D, K, V 	S
	T
R 	W

1 P 2 C 3 K 4 N 5 R 6 20 7 20 8 K 9 12

2 Insert Shape

C	D	K
R	S	T
V	W	

4 Clearance

B
C
N
P

6 Shank Height

Expressed in millimetres
Single Digit Nos. preceded by '0' e.g. h = 8mm is indicated by 08

7 Shank Width

Expressed in millimetres
Single Digit Nos. preceded by '0' e.g. b = 8mm is indicated by 08

8 Tool Length

Length in millimetres			
D	60	M	150
E	70	P	170
F	80	Q	180
H	100	R	200
K	125	S	250

Boring Bars - Additional Designation

1 Bar Type

S	Solid Steel Bar
A	Solid Steel With Through Coolant
C	Carbide Shank
E	Carbide Shank with Through Coolant
T	Anti-Vibration Carbide Reinforced Steel Shank

3 Bar Length

Length in millimetres			
J	110	S	250
K	125	T	300
M	150	U	350
Q	180	V	400
R	200	W	450

Cartridges - Additional Designation

Note: Cutting Edge Lengths are detailed to the lowest whole number e.g. 12.7mm = 12mm

- 1** Clamping System
- 2** Insert Shape
- 3** Lead Angle
- 4** Clearance
- 5** Hand
- 8** Cutting Edge Length

Note: Details as above see External Toolholders

1 2 3 4 5 6 7 8 9
S 50 W P S K N R 19

1 2 3 4 5 6 7 8
P T F N R 16 CA 16

2 Basic Diameter

Expressed in millimetres	
Single Digit Nos. preceded by '0' e.g. b = 8mm is indicated by 08	

- 4** Clamping System
 - 5** Insert Shape
 - 6** Lead Angle
 - 7** Clearance
 - 8** Hand
 - 9** Cutting Edge Length
- Note:** Details as above see External Toolholders

6 Cutting Edge Height

Expressed in millimetres	
Single Digit Nos. preceded by '0' e.g. h ₁ = 8mm is indicated by 08	

7 Type of Tool

'C' Indicates Cartridge
'A' Indicates that Holder is designed to ISO 5611

THREADING TOOLHOLDERS - ISO DESIGNATION

1 Clamping System

D	Top Clamp + Screw-on
S	Screw-on
C	Top Clamp

3 Hand

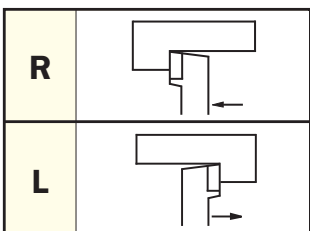

6 Tool Length

Length in millimetres			
H	100	S	250
K	125		
M	150		
P	170		
R	200		

7 Cutting Edge length

	l	ic
06	6mm	5/32"
08	8mm	3/16"
11	11mm	1/4"
16	16.5mm	3/8"
22	22mm	1/2"

1 D 2 E 3 R 4 16 5 16 6 H 7 16

2 Type of holder

E	External
I or N	Internal

4 Shank Height

Round Shank (Boring Bars) = 00
 For Rectangular Shanks, Height is expressed in mm
 Single Digit Nos. preceded by '0'
 E.g. h = 8mm is indicated by 08

5 Shank Width

Round Shank (Boring Bars) = Diameter in mm
 For Rectangular Shanks, Width is expressed in mm
 Single Digit Nos. preceded by '0'
 E.g. h = 8mm is indicated by 08

Dimensional Notation

External Toolholders

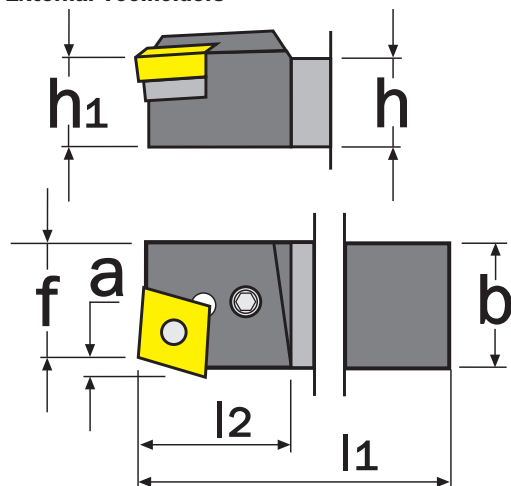

Boring Bars

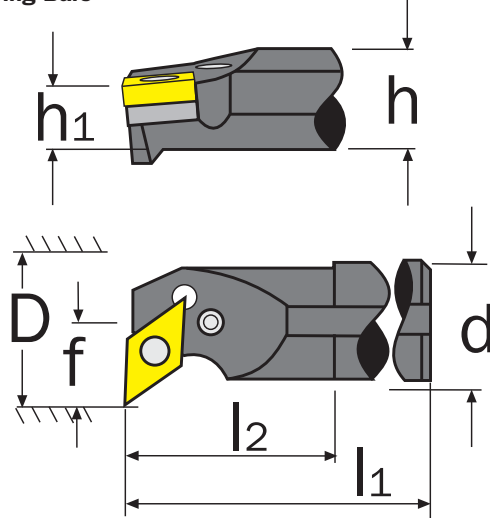

- h = Shank Height or A/F Dmin
- h₁ = Tip Height
- b = Shank Width
- d = Shank Diameter
- f = Width Offset
- a = Insert Approach Length
- D = Min. Boring Diameter
- l₁ = Overall Length to Tip
- l₂ = Neck Length
- l₃ = Min. Adjustment Length
- d₁ = Clamp Screw Bore Diameter
- d₂ = Neck Diameter
- x = Clamp Screw Angle
- e = Clamp Screw Centre

Cartridge Units

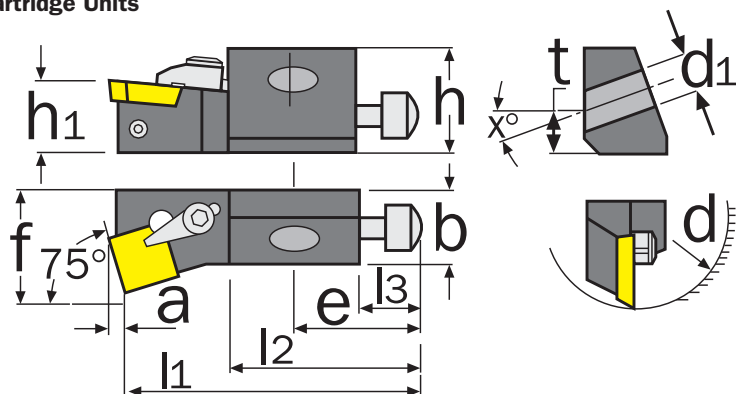

Threading Toolholders

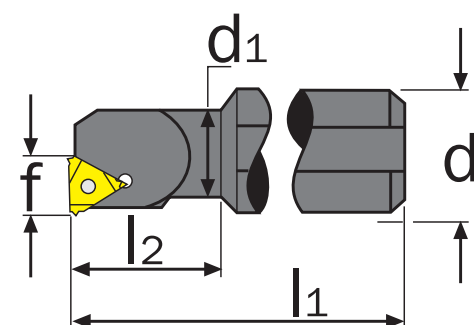

INDEXA-SEIKI™

Indexable Toolholders & Boring Bars

Illustrated are a few basic tool styles from a range that covers the majority of applications in turning. Generally Indexable toolholders use shims made of carbide that lie underneath the inserts in the holder pockets, fixed by means of a pin or screw. They provide clearance and maximum support which is achieved for the insert to absorb the cutting force. In the event of insert fracture, they protect the toolholder from damage.

C-Style Top Clamp

Especially suitable for boring and medium to heavy external turning operations, using positive rakes, various chip breakers and extra side clearance. The clamp is brought down onto the insert by a screw through the clamp. The clamp is designed and positioned so as not to hamper chip flow. When the screw is loosened the clamp lifts and a lug at the back of the clamp keeps it in position. The insert is securely fixed in the two-sided pocket by the positive, direct screw clamp action which gives solid clamping of insert types with no centre hole.



External



Internal

M-Style Combination Clamp & Pin

Suitable for turning and boring operations that require better accessibility than the lever system. The insert is clamped by a top clamp pushing the insert towards a fixed pin. The clamp improves rigidity by wedging the insert against the fixed pin and also clamping the insert down. The insert is held very securely but released through just a slight turn of the screw. The design also provides a clear top face. This design does not provide the same clamping stability as the two sided pocket design of the lever lock type.



External



Internal

Cartridge Units

Many boring, external and combination operations require a number of cuts to be made in a single feed of the tool. In other operations it is wise to distribute the depth of cut on several cutting edges. For this purpose special tools are designed based on standard cartridge units. Compared to tools with fixed insert seats the use of built-in tools gives the following advantage: Relatively small positional tolerances can be maintained. If the tool has to be changed, due to minor modification of the workpiece, the built-in units can be adjusted rather than the entire tool. An expensive tool is not damaged should there be an accident.

These items are available on request. Please contact your distributor for further information.



C-Style



S-Style



P-Style

Widest range of styles and sizes. All compatible with ISO inserts. Complete range of spares in stock. Full technical support services provided.

Performance Tooling
Assured Quality

INDEXA-SEIKI™

Indexable Toolholders & Boring Bars

Illustrated are a few basic tool styles from a range that covers the majority of applications in turning. Generally Indexable toolholders use shims made of carbide that lie underneath the inserts in the holder pockets, fixed by means of a pin or screw. They provide clearance and maximum support which is achieved for the insert to absorb the cutting force. In the event of insert fracture, they protect the toolholder from damage.

P-Style Lever Lock

For external turning and boring of larger diameter holes. Versatile general purpose system for light to heavy machining, utilising a wide range of negative/positive inserts to cover most applications. Inserts are clamped using the centre hole. A pivoted lever tilts by adjustment of the clamping screw. The lever forces the insert backwards into the pocket locating it firmly against two sides giving excellent stability and locating accuracy. This will ensure unobstructed chip flow over the insert top face. Easy to operate for quick indexing.



External



Internal

S-Style Screw-on

For the internal machining of small diameters and for external light roughing to finishing of smaller work pieces. Offers secure insert clamping, excellent repeatability, uninterrupted chip clearance, requires little space and few spares. Suitable for copy turning due to the positive insert being positioned neutrally in the toolholder, giving constant clearance around the periphery and ensuring a clean cut, excellent surface finish and long tool life. The single screw, fits into a hole in the insert pocket holding both insert and shim in place.



External



Internal

Carbide Shank Boring Bars also available

Threading Tools

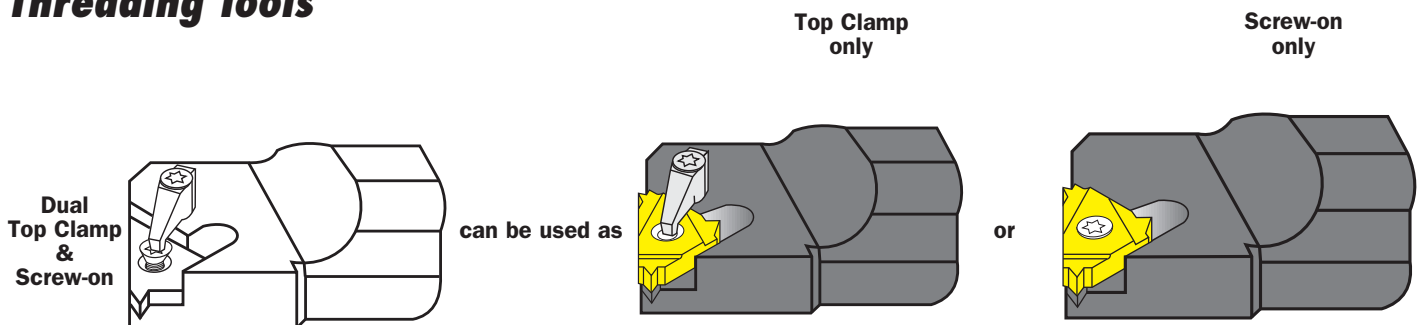

Widest range of styles and sizes. All compatible with ISO inserts. Complete range of spares in stock. Full technical support services provided.

Performance Tooling
Assured Quality

GROUP 106 TOOLHOLDERS - ISO EXTERNAL

INDEXA-SEIKI Top Clamp External Toolholders

CKJN R/L

93° approach for 55° negative parallelogram inserts.



Inserts See Group 120
Sizes **16** = 1604__

KN_X

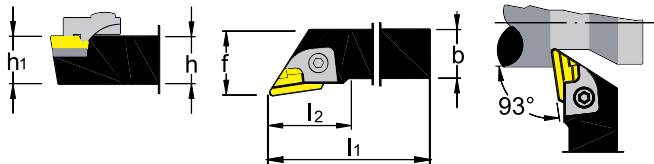

Spares to Suit Contact your local branch for prices

Shim	Shim Pin	Claw	Clamp Screw	Spring	Spring Pin	Hex Key
Order Code IND-107						Order Code KEN-601
-1930K	-2945K	-0670K	-1280K	-0830K	-0840K	-1300K
-1940K	-2945K	-0680K	-1280K	-0830K	-0840K	-1300K

Designation	Dimensions (mm)						Weight each	Order Code	Price/1 TB
	h=h1	b	l1	l2	f				
R 2525M 16	25	25	150	34	32		734g	-0240K	4296.00
L 2525M 16							736g	-0250K	4296.00

CSDP N

45° approach for 11° positive square inserts.



Inserts See Group 120
Sizes **09** = 0903__
Sizes **12** = 1203__

SP_R

SP_N

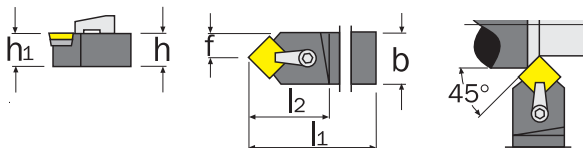

Spares to Suit Contact your local branch for prices

Shim	Shim Pin	Clamp Set				Hex Key
Order Code IND-107						Order Code KEN-601
-1950K	-2950K	-4200K	-	-	-	-1250K
-2000K	-2950K	-4300K	-	-	-	-1300K

Designation	Dimensions (mm)						Weight each	Order Code	Price/1 TB
	h=h1	b	l1	l2	f				
N 1616H 09	16	16	100	22	8.0		194g	-0420K	2295.00
N 2020K 12	20	20	125	28	10.0		380g	-0460K	2733.00

CSSP R/L

45° approach for 11° positive square inserts.



Inserts See Group 120
Sizes **12** = 1203__

SP_R

SP_N

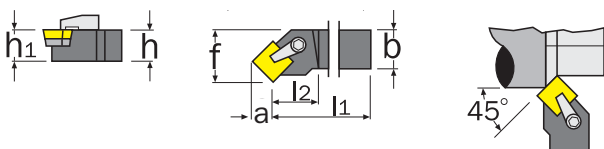

Spares to Suit Contact your local branch for prices

Shim	Shim Pin	Clamp Set				Hex Key
Order Code IND-107						Order Code KEN-601
-2000K	-2950K	-4300K	-	-	-	-1300K

Designation	Dimensions (mm)						Weight each	Order Code	Price/1 TB
	h=h1	b	l1	l2	f	a			
R 2525M 12	25	25	150	28	32	8.3	745g	-0600K	3192.00

INDEXA-SEIKI Top Clamp External Toolholders Continued

CTFP R

90° approach for 11° positive triangular inserts.



Inserts See Group 120

Sizes **11** = 1103__

Sizes **16** = 1603__

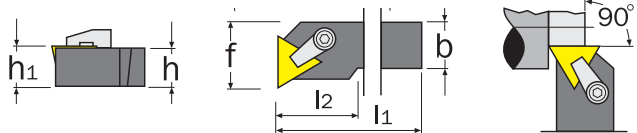

Spares to Suit Contact your local branch for prices

Shim	Shim Pin	Clamp Set					Hex Key
Order Code IND-107							Order Code KEN-601
-	-	-4250K	-	-	-	-	-1250K
-2050K	-2950K	-4300K					-1300K

Designation	Dimensions (mm)					Weight each	Order Code	Price/1 TB
CTFP....	h=h ₁	b	l ₁	l ₂	f		IND-106	
R 1616H 11	16	16	100	22	20	203g	-0900K	3055.00
R 2020K 16	20	20	125	22	25	400g	-0940K	3198.00

CTGP R/L

90° approach for 11° positive triangular inserts.



Inserts See Group 120

Sizes **11** = 1103__

Sizes **16** = 1603__

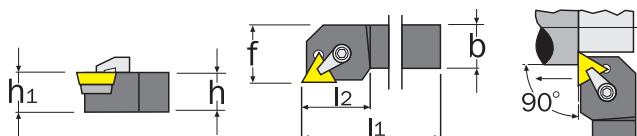

Spares to Suit Contact your local branch for prices

Shim	Shim Pin	Clamp Set					Hex Key
Order Code IND-107							Order Code KEN-601
-	-	-4200K	-	-	-	-	-1250K
-2050K	-2950K	-4300K					-1300K

Designation	Dimensions (mm)					Weight each	Order Code	Price/1 TB
CTGP....	h=h ₁	b	l ₁	l ₂	f		IND-106	
R 1212F 11	12	12	80	18	16	98g	-1040K	2624.00
L 1212F 11						97g	-1050K	2624.00
R 1616H 11	16	16	100	22	20	207g	-1060K	2498.00
R 2020K 16	20	20	125	28	25	397g	-1100K	2569.00
L 2020K 16						395g	-1110K	2569.00
R 2525M 16	25	25	150	28	32	744g	-1120K	2761.00
L2525M 16						744g	-1130K	2761.00

Combination Top Clamp & Pinlock External Toolholders

MTJN R

93° approach for negative triangular inserts.



Inserts See Group 120

Sizes : **16** = 1604

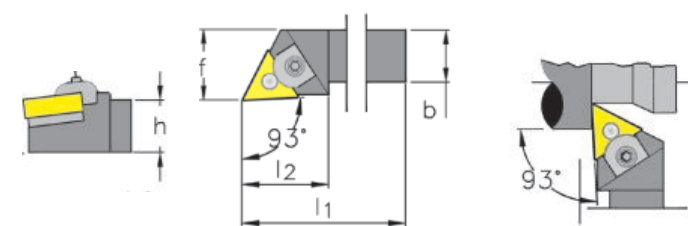

Spares to Suit Contact your local branch for prices

Shim	Lock Pin	Clamp					
Order Code IND-107							
-2087K	-1480K	-0943K	-	-	-	-	-

Designation	Dimensions (mm)					Weight each	Order Code	Price/1 TB
MTJN....	h=h ₁	b	l ₁	l ₂	f		IND-106	
R 2020K 16	20	20	125	34	25	427g	-1300K	2733.00
R 2525M 16	25	25	150	34	32	753g	-1320K	2761.00

INDEXA-SEIKI *Combination Top Clamp & Pinlock External Toolholders*



MVJN R/L

93° approach for negative 35° rhombic inserts.



Inserts See Group 120
Sizes **16** = 1604__



CUTTING TOOLS

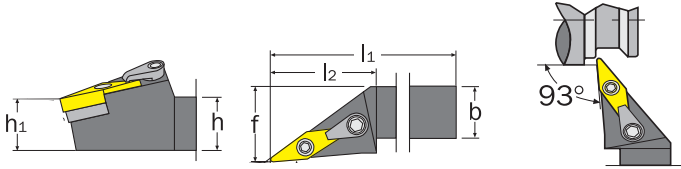

Spares to Suit Contact your local branch for prices

Shim	Lock Pin	Clamp	Clamp Screw			Shim Key	Clamp Key
Order Code IND-107						Order Code KEN-601	
-2100K	-1600K	-0600K	-0900K	-	-	-1200K	-1300K
-2100K	-1600K	-0600K	-0900K	-	-	-1200K	-1300K

Designation MVJN....	Dimensions (mm)					Weight each	Order Code IND-106	Price/1 TB
	h=h1	b	l1	l2	f			
R 2020K 16	20	20	125	37	25	395g	-1500K	2771.00
L 2020K 16	20	20	125	37	25	398g	-1510K	2842.00
R 2525M 16	25	25	150	37	32	679g	-1520K	3198.00
L 2525M 16	25	25	150	37	32	688g	-1530K	4126.00

MVJN N

72.5° approach for negative 35° rhombic inserts.



Inserts See Group 120
Size **16** = 1604__

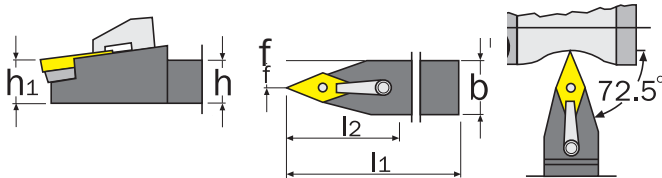

Spares to Suit Contact your local branch for prices

Shim	Lock Pin	Clamp	Clamp Screw			Shim Key	Clamp Key
Order Code IND-107						Order Code KEN-601	
-2100K	-1600K	-0600K	-0900K	-	-	-1200K	-1300K
-2100K	-1600K	-0600K	-0900K	-	-	-1200K	-1300K

Designation MVJN....	Dimensions (mm)					Weight each	Order Code IND-106	Price/1 TB
	h=h1	b	l1	l2	f			
N 2020K 16	20	20	125	48	10.0	379g	-1580K	3873.00
N 2525M 16	25	25	150	48	12.5	675g	-1600K	4126.00

MWLN R/L

95° approach for negative 80° trigon inserts.



Inserts See Group 120
Sizes **08** = 0804__

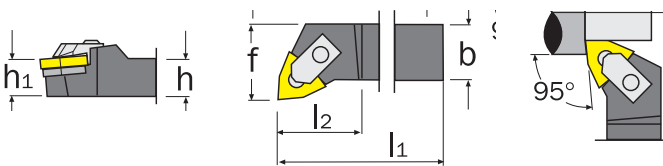

Spares to Suit Contact your local branch for prices

Shim	Lock Pin	Clamp	Clamp Screw			Shim Key	Clamp Key
Order Code IND-107						Order Code KEN-601	
-2920K	-1680K	-0940K	-0080K	-	-	-1250K	-1500K
-2920K	-1680K	-0940K	-0080K	-	-	-1250K	-1500K

Designation MWLN....	Dimensions (mm)					Weight each	Order Code IND-106	Price/1 TB
	h=h1	b	l1	l2	f			
R 2020K 08	20	20	125	34	25	453g	-1680K	2935.00
L 2020K 08	20	20	125	34	25	465g	-1690K	2935.00
R 2525M 08	25	25	150	34	32	789g	-1700K	2979.00
L 2525M 08	25	25	150	34	32	776g	-1710K	2979.00

INDEXA-SEIKI Lever Lock External Toolholders



CUTTING TOOLS

PCBN R/L

75° approach for negative 80° rhombic inserts.

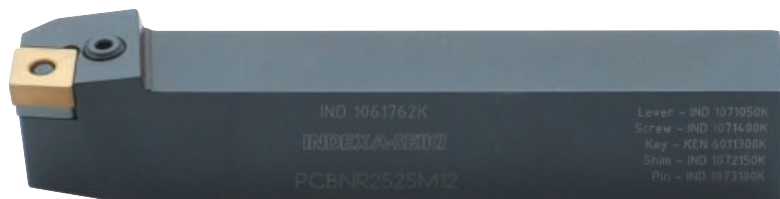

Inserts See Group 120
 Sizes **12** = 1204__
 Sizes **16** = 1606__

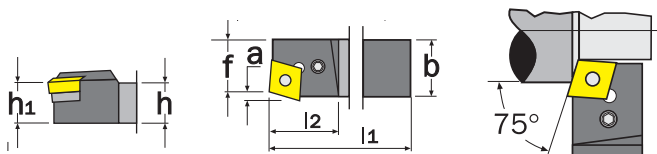

Spares to Suit Contact your local branch for prices

Shim	Shim Pin	Lever	Lever Screw				Hex Key
Order Code IND-107							Order Code KEN-601
-2150K	-3100K	-1050K	-1400K	-	-	-	-1300K
-2150K	-3100K	-1050K	-1400K	-	-	-	-1300K

Designation PCBN....	Dimensions (mm)						Weight each	Order Code IND-106	Price/1 TB
	h=h1	b	l1	l2	f	a			
R 2525M 12	25	25	150	28	22	3.1	730g	-1762K	2733.00
L 2525M 12	25	25	150	28	22	3.1	725g	-1763K	2733.00

PCKN R/L

75° approach for negative 80° rhombic inserts.



Inserts See Group 120
 Sizes **12** = 1204__

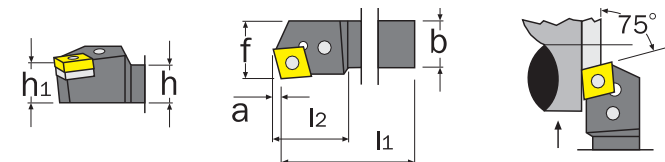

Spares to Suit Contact your local branch for prices

Shim	Shim Pin	Lever	Lever Screw				Hex Key
Order Code IND-107							Order Code KEN-601
-2150K	-3100K	-1050K	-1400K	-	-	-	-1300K
-2150K	-3100K	-1050K	-1400K	-	-	-	-1300K

Designation PCKN....	Dimensions (mm)						Weight each	Order Code IND-106	Price/1 TB
	h=h1	b	l1	l2	f	a			
R 2020K 12	20	20	125	28	25	3.1	408g	-1820K	2733.00
R 2525M 12	25	25	150	34	22	3.8	760g	-1860K	2870.00

PCLN R/L

95° approach for negative 80° rhombic inserts.



Inserts See Group 120
 Sizes **09** = 0903__
 Sizes **12** = 1204__
 Sizes **16** = 1606__
 Sizes **19** = 1906__

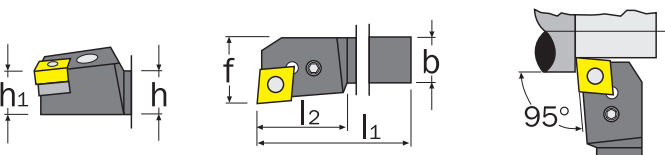
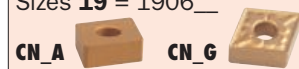

Spares to Suit Contact your local branch for prices

Shim	Shim Pin	Lever	Lever Screw				Hex Key
Order Code IND-107							Order Code KEN-601
-2150K	-3100K	-1260K	-1500K	-	-	-	-1300K
-2130K	-3050K	-0950K	-1300K	-	-	-	-1250K
-2150K	-3100K	-1050K	-1400K	-	-	-	-1300K
-2150K	-3100K	-1050K	-1400K	-	-	-	-1300K
-2860K	-3150K	-1220K	-1590K	-	-	-	-1300K
-2150K	-3100K	-1050K	-1400K	-	-	-	-1300K

Designation PCLN....	Dimensions (mm)						Weight each	Order Code IND-106	Price/1 TB
	h=h1	b	l1	l2	f	a			
R 1616H 12	16	16	100	26	20	206g	-1960K	3055.00	
R 2020K 09	20	20	125	28	25	406g	-1980K	3198.00	
R 2020K 12	20	20	125	28	25	404g	-2000K	3388.00	
L 2020K 12	20	20	125	28	25	404g	-2010K	3388.00	
R 2525M 12	25	25	150	28	32	742g	-2040K	2924.00	
L 2525M 12	25	25	150	28	32	738g	-2050K	2924.00	
R 2525M 16	25	25	150	34	32	743g	-2060K	2924.00	
L 2525M 16	25	25	150	34	32	749g	-2070K	3416.00	
R 3225P 12	32	25	170	28	32	1067g	-2100K	3055.00	
L 3225P 12	32	25	170	28	32	1045g	-2210K	3055.00	

PRODUCTS ARE ONLY AVAILABLE VIA YOUR DISTRIBUTOR

GROUP 106 TOOLHOLDERS - ISO EXTERNAL



INDEXA-SEIKI Lever Lock External Toolholders Continued



PDJN R/L





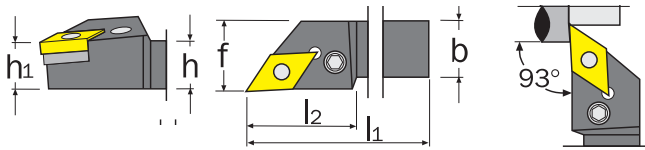

93° approach for negative 55° rhombic inserts.



Inserts See Group 120
 Sizes **11** = 1104__
 Sizes **15** = 1506__
 = 1504__ (optional)
DN_A  **DN_G** 



Spares to Suit Contact your local branch for prices



		Optional 				
1104_ Shim	1506_ Shim	1504_ Shim	Shim Pin	Lever	Lever Screw	Hex Key
Order Code IND-107						Order Code KEN-601
-2800K	-	-	-3050K	-0950K	-1300K	-
-	-2250K	-2270K	-3100K	-1100K	-1410K	-
-2800K	-	-	-3050K	-0950K	-1300K	-
-	-2250K	-2270K	-3100K	-1100K	-1410K	-

Designation PDJN....	Dimensions (mm)					Weight each	Order Code IND-106	Price/1 TB
	h=h1	b	l1	l2	f			
R 2020K 11	20	20	125	30	25	386g	-2380K	2596.00
L 2020K 11	20	20	125	34	25	383g	-2390K	2596.00
R 2020K 15	20	20	125	34	25	383g	-2400K	2569.00
L 2020K 15	20	20	125	34	25	393g	-2410K	2569.00
R 2525M 11	25	25	150	33	32	715g	-2420K	2946.00
L 2525M 11	25	25	150	33	32	715g	-2430K	2946.00
R 2525M 15	25	25	150	34	32	726g	-2440K	2946.00
L 2525M 15	25	25	150	34	32	720g	-2450K	2946.00

PDNN R

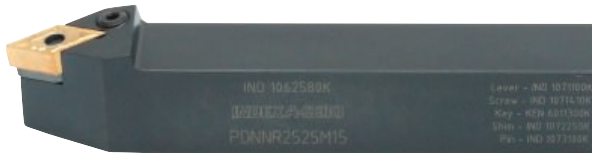



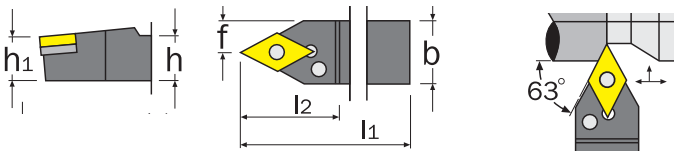

63° approach for negative 55° rhombic inserts.



Inserts See Group 120
 Sizes **15** = 1506__
 = 1504__ (optional)
DN_A  **DN_G** 



Spares to Suit Contact your local branch for prices



	Optional 				
1506_ Shim	1504_ Shim	Shim Pin	Lever	Lever Screw	Hex Key
Order Code IND-107					Order Code KEN-601
-2250K	-2270K	-3100K	-1100K	-1410K	-
-	-	-	-	-	-1300K

Designation PDNN....	Dimensions (mm)					Weight each	Order Code IND-106	Price/1 TB
	h=h1	b	l1	l2	f			
R 2525M 15	25	25	150	34	12.5	689g	-2580K	2924.00

PRSN R

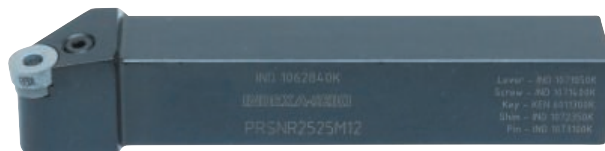



90° approach for negative round inserts.

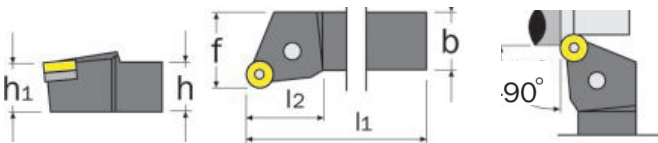

Inserts See Group 120
 Size **12** = 120400
 Sizes **19** = 190600
RN_A  **RN_G** 



Spares to Suit Contact your local branch for prices



				
Shim	Shim Pin	Lever	Lever Screw	Hex Key
Order Code IND-107				Order Code KEN-601
-2350K	-3100K	-1050K	-1400K	-
-	-	-	-	-1300K

Designation PRSN....	Dimensions (mm)					Weight each	Order Code IND-106	Price/1 TB
	h=h1	b	l1	l2	f			
R 2525M 12	25	25	150	28	32	715g	-2840K	2924.00

PSBN R/L





75° approach for negative square inserts.

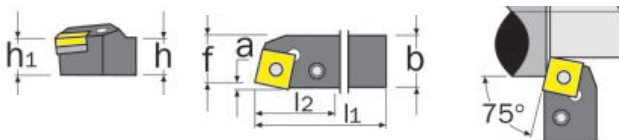

Inserts See Group 120
 Sizes **09** = 0903__
 Sizes **12** = 1204__
 Sizes **19** = 1906__
SN_A  **SN_G** 



Spares to Suit Contact your local branch for prices

				
Shim	Shim Pin	Lever	Lever Screw	Hex Key
Order Code IND-107				Order Code KEN-601
-2500K	-3100K	-1050K	-1400K	-
-	-	-	-	-1300K

Designation PSBN....	Dimensions (mm)						Weight each	Order Code IND-106	Price/1 TB
	h=h1	b	l1	l2	f	a			
R 2020K 12	20	20	125	28	17	3	390g	-2940K	2558.00
L 2020K 12	20	20	125	28	17	3	390g	-2950K	3251.00
R 2525M 12	25	25	150	28	22	3	716g	-2960K	3225.00

INDEXA-SEIKI **Lever Lock External Toolholders** continued



CUTTING TOOLS

PSDN N

45° straight approach for negative square inserts.



Inserts See Group 120
Size **12** = 1204__
Size **19** = 1906__

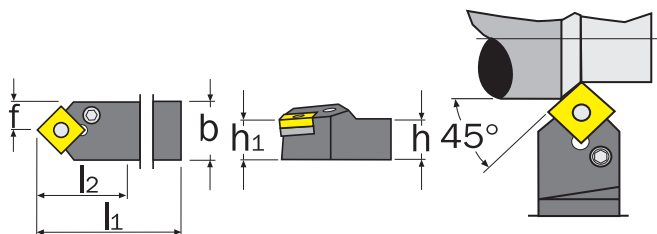

Designation PSDN...	Dimensions (mm)					Weight each	Order Code IND-106	Price/1 TB
	h=h ₁	b	l ₁	l ₂	f			
N 2020K 12	20	20	125	28	10.0		-3220K	2619.00
N 2525M 12	25	25	150	28	12.5		-3240K	2924.00
N 3225P 19	32	25	170	42	12.5		-3280K	3142.00

Spares to Suit Contact your local branch for prices

Shim	Shim Pin	Lever	Lever Screw				Hex Key
Order Code IND-107							Order Code KEN-601
-2500K	-3100K	-1050K	-1400K	-	-	-	-1300K
-2500K	-3100K	-1050K	-1400K	-	-	-	-1300K
-2550K	-3200K	-1250K	-1580K	-	-	-	-1400K

PSKN R/L

75° approach for negative square inserts.

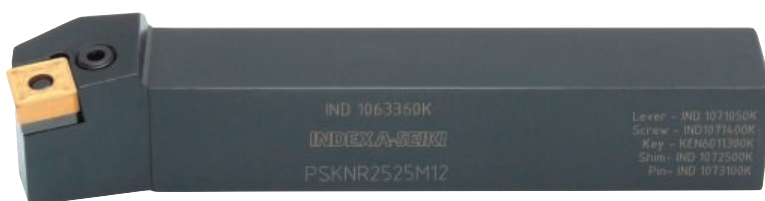

Inserts See Group 120
Size **12** = 1204__

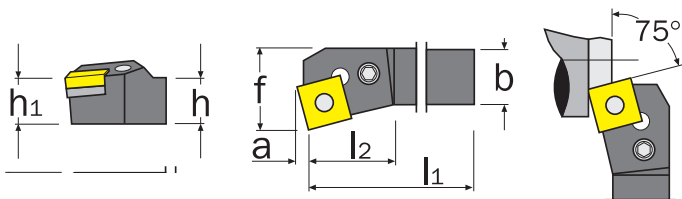

Designation PSKN...	Dimensions (mm)							Weight each	Order Code IND-106	Price/1 TB
	h=h ₁	b	l ₁	l ₂	f	a				
R 2525M 12	25	25	150	28	32	3.1		-3360K	2733.00	

Spares to Suit Contact your local branch for prices

Shim	Shim Pin	Lever	Lever Screw				Hex Key
Order Code IND-107							Order Code KEN-601
-2500K	-3100K	-1050K	-1400K	-	-	-	-1300K

PSSN R/L

45° offset approach for negative square inserts.

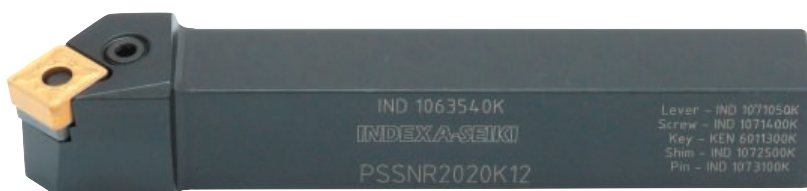

Inserts See Group 120
Size **12** = 1204__
Size **19** = 1906__

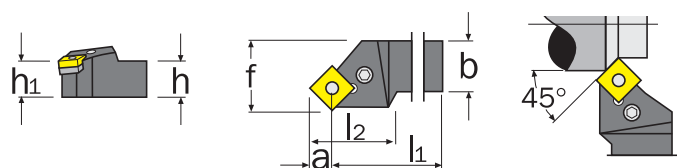

Designation PSSN...	Dimensions (mm)							Weight each	Order Code IND-106	Price/1 TB
	h=h ₁	b	l ₁	l ₂	f	a				
R 2020K 12	20	20	125	28	25	8.3		-3540K	2733.00	
L 2020K 12								-3550K	2733.00	
R 2525M 12	25	25	150	28	32	8.3		-3560K	2924.00	
L 2525M 12								-3570K	2924.00	
R 3232P 19	32	32	170	42	40	12.5		-3660K	3689.00	

Spares to Suit Contact your local branch for prices

Shim	Shim Pin	Lever	Lever Screw				Hex Key
Order Code IND-107							Order Code KEN-601
-2500K	-3100K	-1050K	-1400K	-	-	-	-1300K
-2500K	-3100K	-1050K	-1400K	-	-	-	-1300K
-2550K	-3200K	-1250K	-1580K	-	-	-	-1400K

GROUP 106 TOOLHOLDERS - ISO EXTERNAL

INDEXA-SEIKI Lever Lock External Toolholders Continued



PTFN R/L

90° approach for negative triangular inserts.



Inserts See Group 120
Size **16** = 1604__

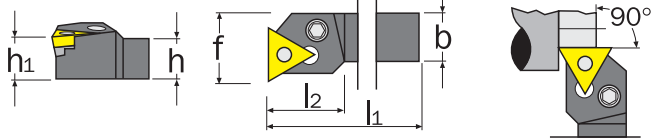

Spares to Suit Contact your local branch for prices

Shim	Shim Pin	Lever	Lever Screw				Hex Key
Order Code IND-107							Order Code KEN-601
-2450K	-3050K	-0950K	-1300K	-	-	-	-1250K
-2450K	-3050K	-0950K	-1300K	-	-	-	-1250K

Designation	Dimensions (mm)					Weight each	Order Code	Price/1 TB
PTFN....	h=h1	b	l1	l2	f		IND-106	
R 2020K 16	20	20	125	22	25		-3680K	2733.00
R 2525M 16	25	25	150	22	32		-3740K	2924.00

PTGN R/L

90° approach for negative triangular inserts.

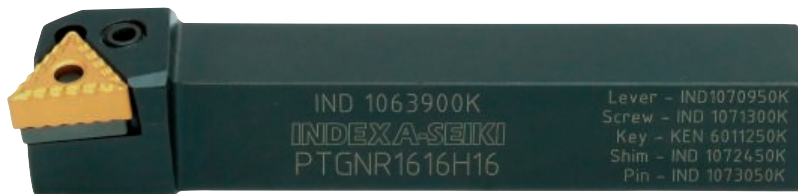

Inserts See Group 120
Size **16** = 1604__
Size **22** = 2204__

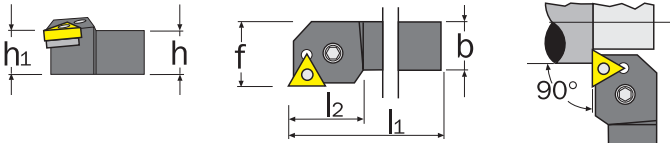

Spares to Suit Contact your local branch for prices

Shim	Shim Pin	Lever	Clamp Screw				Hex Key
Order Code IND-107							Order Code KEN-601
-2450K	-3050K	-0950K	-1300K	-	-	-	-1250K
-2450K	-3050K	-0950K	-1300K	-	-	-	-1250K
-2450K	-3050K	-0950K	-1300K	-	-	-	-1250K
-2450K	-3050K	-0950K	-1300K	-	-	-	-1250K
-2600K	-3100K	-1050K	-1400K	-	-	-	-1300K

Designation	Dimensions (mm)					Weight each	Order Code	Price/1 TB
PTGN....	h=h1	b	l1	l2	f		IND-106	
R 1616H 16							-3900K	3689.00
L 1616H 16	16	16	100	22	20		-3910K	3664.00
R 2020K 16							-3940K	2678.00
L 2020K 16	20	20	125	22	25		-3950K	2678.00
R 2525M 16							-3960K	2924.00
L 2525M 16	25	25	150	22	32		-3970K	2924.00
R 2525M 22	25	25	150	28	32		-3980K	2924.00

PWLN R/L

95° approach for negative 80° trigon inserts.

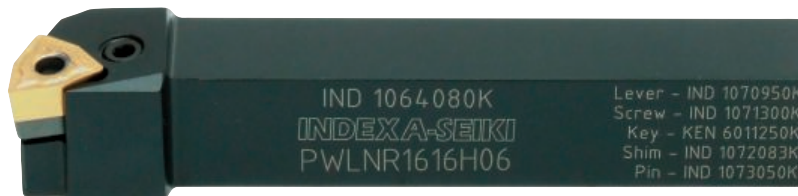

Inserts See Group 120
Size **06** = 0604__
Size **08** = 0804__

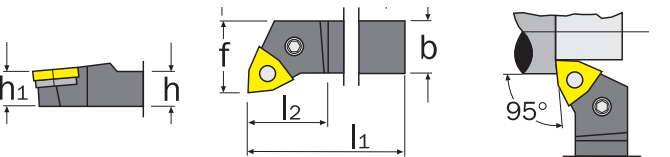

Spares to Suit Contact your local branch for prices

Shim	Shim Pin	Lever	Clamp Screw				Hex Key
Order Code IND-107							Order Code KEN-601
-2083K	-3050K	-0950K	-1300K	-	-	-	-1250K
-2083K	-3050K	-0950K	-1300K	-	-	-	-1250K
-2084K	-3100K	-1050K	-1400K	-	-	-	-1300K
-2083K	-3050K	-0950K	-1300K	-	-	-	-1250K
-2084K	-3100K	-1050K	-1400K	-	-	-	-1300K

Designation	Dimensions (mm)					Weight each	Order Code	Price/1 TB
PWLN....	h=h1	b	l1	l2	f		IND-106	
R 1616H 06							-4080K	2924.00
L 1616H 06	16	16	100	21	20		-4082K	2924.00
R 2020K 06	20	20	125	25	25		-4090K	2924.00
L 2020K 06	20	20	125	25	25		-4092K	2924.00
R 2020K 08							-4100K	2924.00
L 2020K 08	20	20	125	25	25		-4110K	2924.00
R 2525M 06							-4114K	2924.00
L 2525M 06	25	25	150	34	32		-4116K	2924.00
R 2525M 08							-4120K	2924.00
L 2525M 08	25	25	150	34	32		-4130K	2924.00

INDEXA-SEIKI

Screw-On External Toolholders Continued



SCLC R/L

95° approach for 7° positive
80° rhombic inserts.



Inserts See Group 120
Size **06** = 0602__
Size **09** = 09T3__
Size **12** = 1204__

CC_T

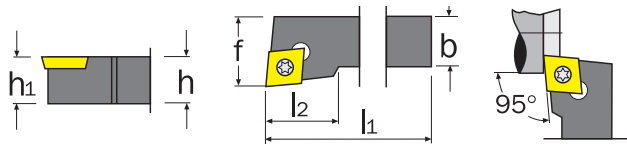

Spares to Suit Contact your local branch for prices

Shim	Shim Screw	Insert Screw						Torx Key
Order Code IND-107								
-	-	-3250K	-	-	-	-	-	-5070K
-	-	-3270K	-	-	-	-	-	-5150K
-	-	-3270K	-	-	-	-	-	-5150K
-	-	-3270K	-	-	-	-	-	-5150K
-	-	-3270K	-	-	-	-	-	-5150K
-2180K	-1575K	-1275K	-	-	-	-	-	-5200K
-2180K	-1575K	-1275K	-	-	-	-	-	-5150K

SDJC R/L

93° approach for 7° positive
55° rhombic inserts.



Inserts See Group 120
Size **07** = 0702__
Size **11** = 11T3__

DC_T

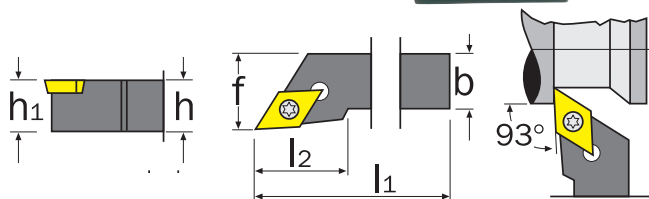

Spares to Suit Contact your local branch for prices

Shim	Shim Screw	Insert Screw						Torx Key
Order Code IND-107								
-	-	-3250K	-	-	-	-	-	-5070K
-	-	-3250K	-	-	-	-	-	-5070K
-	-	-3400K	-	-	-	-	-	-5150K
-2246K	-1570K	-3400K	-	-	-	-	-	-5150K
-2246K	-1570K	-3400K	-	-	-	-	-	-5150K
-2246K	-1570K	-3400K	-	-	-	-	-	-5150K

SDNC N

62.5° approach for 7° positive
55° rhombic inserts.

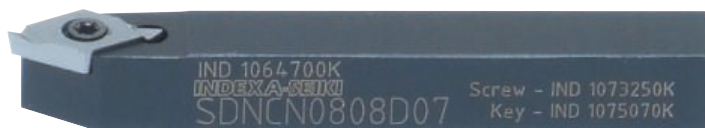

Inserts See Group 120
Size **07** = 0702__
Size **11** = 11T3__

DC_T

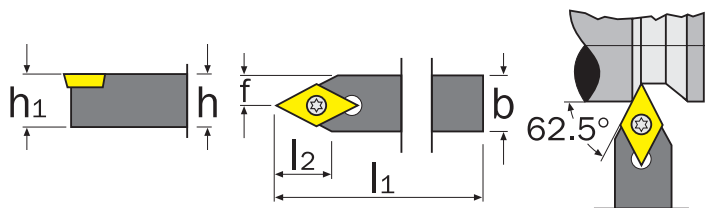

Spares to Suit Contact your local branch for prices

Shim	Shim Screw	Insert Screw						Torx Key
Order Code IND-107								
-	-	-3250K	-	-	-	-	-	-5070K
-	-	-3250K	-	-	-	-	-	-5070K
-2246K	-1570K	-3400K	-	-	-	-	-	-5150K
-2246K	-1570K	-3400K	-	-	-	-	-	-5150K

Designation	Dimensions (mm)	Weight	Order Code	Price/1
SDNC....	h=h1 b l1 l2 f	each	IND-106	TB
N 1010E 07	10 10 70 16 5.0		-4720K	2728.00
N 1212F 07	12 12 80 18 6.0		-4740K	2728.00
N 1616H 11	16 16 100 22 8.0		-4780K	2728.00
N 2020K 11	20 20 125 22 10.0		-4800K	2728.00



SRDC N

90° approach for positive round inserts.



Inserts See Group 120
 Sizes **06** = 0602MO.
 Sizes **08** = 0803MO.



CUTTING TOOLS

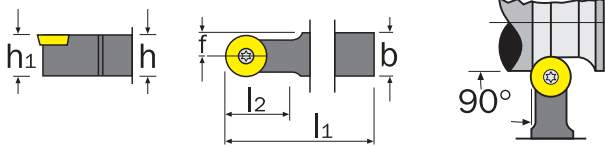

Spares to Suit Contact your local branch for prices

Insert Screw										Torx Key	
Order Code IND-107											
N 2020K 06	20	20	125	20	13.0	-4950K	2728.00	-3250K	-	-	-5070K
N 2020K 08	20	20	125	20	14.0	-4960K	2728.00	-3264K	-	-	-5090K
N 2525M 06	25	25	150	25	15.5	-4970K	2728.00	-3250K	-	-	-5070K
N 2525M 08	25	25	150	25	16.5	-4980K	2728.00	-3264K	-	-	-5090K

SSDC N

45° approach for 7° positive square inserts.



Inserts See Group 120
 Sizes **09** = 09T3____
 Sizes **12** =1204____

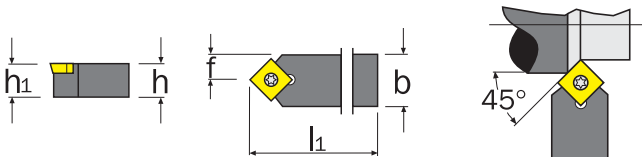

Spares to Suit Contact your local branch for prices

Shim	Shim Screw	Insert Screw								Torx Key	
Order Code IND-107											
N 1212F 09	12	12	80	-	6	-5160K	2728.00	-3270K	-	-	-5150K
N 1616H 09	16	16	100	-	8	-5180K	2761.00	-3270K	-	-	-5150K
N 2020K 12	20	20	125	-	10	-5200K	2814.00	-2090K	-1575K	-1275K	-5200K

SSSC R/L

45° approach for 7° positive square inserts.



Inserts See Group 120
 Size **09** = 09T3____
 Size **12** =1204____

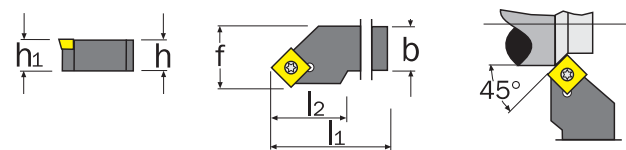

Spares to Suit Contact your local branch for prices

Shim	Shim Screw	Insert Screw								Torx Key	
Order Code IND-107											
R 1212F 09	12	12	80	22	20	-5310K	2814.00	-3270K	-	-	-5150K
R 1616H 09	16	16	100	22	20	-5350K	2814.00	-3270K	-	-	-5150K
R 2020K 12	20	20	125	22	25	-5390K	2814.00	-2090K	-1570K	-1275K	-5200K

INDEXA-SEIKI

Screw-On External Toolholders Continued



CUTTING TOOLS

STGC R/L

90° approach for 7° positive triangular inserts.



Inserts See Group 120
 Sizes **11** = 1102__
 Sizes **16** = 16T3__

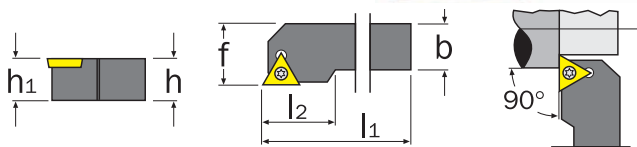

Designation STGC....	Dimensions (mm)					Weight each	Order Code IND-106	Price/1 TB
	h=h ₁	b	l ₁	l ₂	f			
R 1212F 11	12	12	80	18	16		-5660K	2814.00
R 1616H 11	16	16	100	22	20		-5680K	2814.00
R 2020K 16	20	20	125	22	25		-5740K	2814.00
L 2020K 16	20	20	125	22	25		-5750K	2814.00
R 2525M 16	25	25	150	22	32		-5760K	2837.00

Spares to Suit Contact your local branch for prices

Shim	Shim Screw	Insert Screw							Torx Key
Order Code IND-107									
-	-	-3250K	-	-	-	-	-	-	-5070K
-	-	-3250K	-	-	-	-	-	-	-5070K
-2087K	-1570K	-3400K	-	-	-	-	-	-	-5150K
-2087K	-1570K	-3400K	-	-	-	-	-	-	-5150K

SVJN R/L

93° approach for 35° negative rhombic inserts.



Inserts See Group 120
 Size **12** = 12T3__

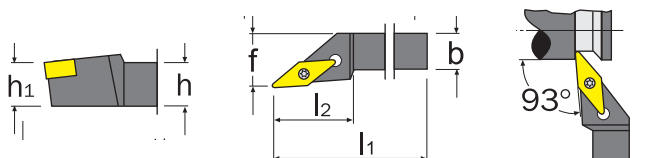

Designation SVJN....	Dimensions (mm)					Weight each	Order Code IND-106	Price/1 TB
	h=h ₁	b	l ₁	l ₂	f			
R 2020K 12	20	20	125	22	25		-5830K	4509.00
L 2020K 12	20	20	125	22	25		-5840K	4509.00
R 2525M 12	25	25	150	31	32		-5850K	4848.00

Spares to Suit Contact your local branch for prices

Insert Screw								Torx Key	Hex Key
Order Code IND-107									
-	-	-3520K	-	-	-	-	-	-5090K	-0080K
-	-	-3520K	-	-	-	-	-	-5090K	-

SVLB R/L

95° approach for 5° positive 35° rhombic inserts.

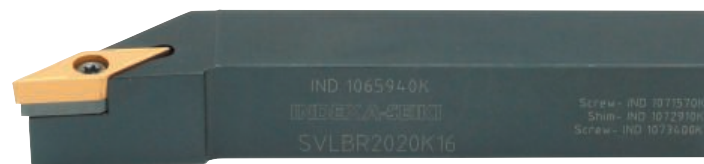

Inserts See Group 120
 Size : **16** = 1604

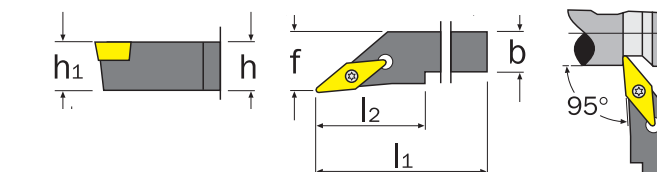

Designation SVLB....	Dimensions (mm)					Weight each	Order Code IND-106	Price/1 TB
	h=h ₁	b	l ₁	l ₂	f			
R 2020K 16	20	20	125	42	25		-5940K	3116.00
L 2020K 16	20	20	125	42	25		-5950K	3165.00
R 2525M 16	25	25	150	42	32		-6020K	3361.00
L 2525M 16	25	25	150	42	32		-6030K	3361.00

Spares to Suit Contact your local branch for prices

Shim	Shim Screw	Insert Screw							Torx Key
Order Code IND-107									
-2910K	-1570K	-3400K	-	-	-	-	-	-	-5150K
-2910K	-1570K	-3400K	-	-	-	-	-	-	-5150K

SVVB N

72.5° approach for 5° positive 35° rhombic inserts.



Inserts See Group 120
 Size : **16** = 1604

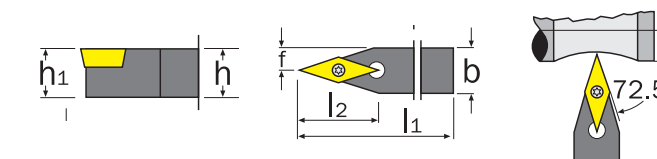

Designation SVVB....	Dimensions (mm)					Weight each	Order Code IND-106	Price/1 TB
	h=h ₁	b	l ₁	l ₂	f			
N 2020K 16	20	20	125	28	10.6		-6080K	3142.00
N 2525M 16	25	25	150	28	13.1		-6100K	3361.00
N 3225P 16	32	25	170	28	13.1		-6120K	3826.00

Spares to Suit Contact your local branch for prices

Shim	Shim Screw	Insert Screw							Torx Key
Order Code IND-107									
-2910K	-1570K	-3400K	-	-	-	-	-	-	-5150K
-2910K	-1570K	-3400K	-	-	-	-	-	-	-5150K
-2910K	-1570K	-3400K	-	-	-	-	-	-	-5150K

INDEXA-SEIKI Top Clamp Boring Bars

CTFP R/L

90° approach for 11° positive triangular inserts.



Inserts See Group 120
 Sizes **11** = 1103__
 Sizes **16** = 1603__

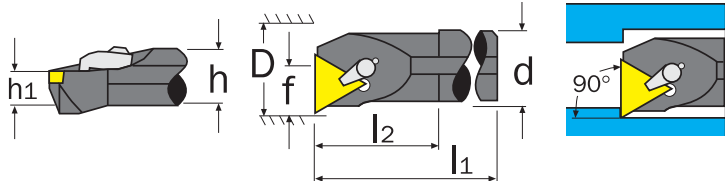

Spares to Suit Contact your local branch for prices

Shim	Shim Pin	Clamp Set					Hex Key
Order Code IND-107							Order Code KEN-601
-	-	-4250K	-	-	-	-	-1250K
-	-	-4210K	-	-	-	-	-1250K
-	-	-4210K	-	-	-	-	-1250K
-	-	-4220K	-	-	-	-	-1300K
-2050K	-2950K	-4300K	-	-	-	-	-1300K

ISO Designation	dg7	h	h1	l1	l2	f	Dmin	Weight each	Order Code IND-106	Price/1 TB
S12M CTFPR 11	12	11	5.5	150	25	9	16		-6400K	3601.00
S16R CTFPR 11	16	15	7.5	200	30	11	20		-6410K	3225.00
S20S CTFPR 11	20	18	9.0	250	35	13	24		-6420K	3919.00
S25T CTFPR 16	25	23	11.5	300	40	17	31		-6460K	4453.00
S32U CTFPR 16	32	30	15.0	350	50	22	39		-6480K	5350.00

Top Clamp & Pin Lock Boring Bars

MWLN R/L

95° approach for 80° negative trigon inserts.



Inserts See Group 120
 Sizes **08** = 0804__

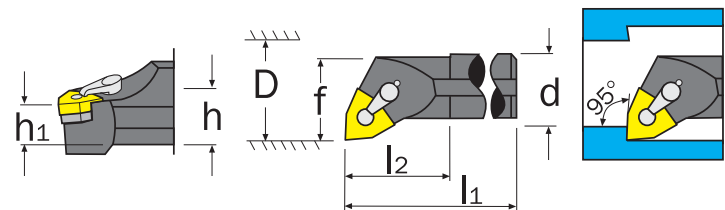

Spares to Suit Contact your local branch for prices

Shim	Lock Pin	Clamp Set	Clamp Screw				Shim Key	Hex Key
Order Code IND-107							Order Code KEN-601	
-	-1490K	-0940K	-1880K	-	-	-	-1250K	-1500K
-2920K	-1680K	-0940K	-1880K	-	-	-	-1250K	-1500K
-2920K	-1680K	-0940K	-1880K	-	-	-	-1250K	-1500K

ISO Designation	dg7	h	h1	l1	l2	f	Dmin	Weight each	Order Code IND-106	Price/1 TB
S25T MWLNR 08	25	23	11.5	300	40	17	31		-6770K	5683.00
S25T MWLNL 08	25	23	11.5	300	40	17	31		-6772K	8181.00
S32U MWLNR 08	32	30	15.0	350	50	22	39		-6776K	8181.00
S40V MWLNR 08	40	37	18.5	400	60	27	48		-6782K	8661.00

Lever Lock Boring Bars

PCLN R/L

95° approach for 80° negative rhombic inserts.



Inserts See Group 120

Sizes **09** = 0903__
 Sizes **12** = 1204__
 Sizes **16** = 1606__

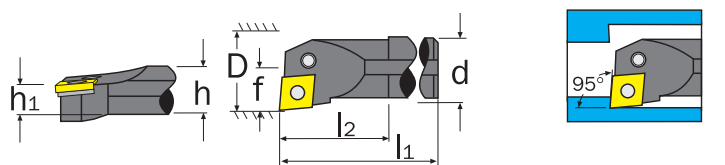

Spares to Suit Contact your local branch for prices

Shim	Shim Pin	Lever	Lever Screw				Hex Key
Order Code IND-107							Order Code KEN-601
-	-3050K	-0950K	-1450K	-	-	-	-1250K
-	-3100K	-1150K	-1450K	-	-	-	-1250K
-2150K	-3100K	-1260K	-1500K	-	-	-	-1300K
-2150K	-3100K	-1260K	-1500K	-	-	-	-1300K
-2860K	-3150K	-1220K	-1590K	-	-	-	-1300K

ISO Designation	dg7	h	h1	l1	l2	f	Dmin	Weight each	Order Code IND-106	Price/1 TB
S25T PCLNR 09	25	23	11.5	300	33	17.0	32		-6800K	6104.00
S25T PCLNR 12	25	23	11.5	300	40	17.0	31		-6820K	6104.00
S25T PCLNL 12	25	23	11.5	300	40	17.0	31		-6830K	6175.00
S32U PCLNR 12	32	30	15.0	350	50	22.0	39		-6840K	7295.00
S32U PCLNL 12	32	30	15.0	350	50	22.0	39		-6850K	7295.00
S40V PCLNR 12	40	37	18.5	400	60	27.0	48		-6860K	8470.00
S40V PCLNL 12	40	37	18.5	400	60	27.0	48		-6870K	8470.00
S50W PCLNR 16	50	47	23.5	450	65	35.0	61		-6880K	10803.00

CUTTING TOOLS

INDEXA-SEIKI Lever Lock Boring Bars

PDUN R/L

93° approach for 55° negative rhombic inserts.

Inserts See Group 120
 Sizes **11** = 1104__
 Sizes **15** = 1506__

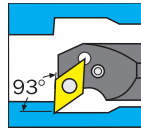
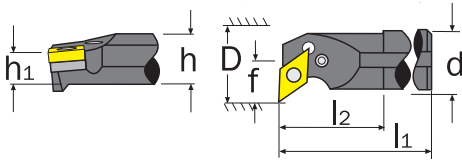

Spares to Suit Contact your local branch for prices

Shim	Shim Pin	Lever	Lever Screw				Hex Key
Order Code IND-107							Order Code KEN-601

ISO Designation	dg7	h	h1	l1	l2	f	Dmin	Weight each	Order Code IND-106	Price/1 TB
S25T PDUNR 11	25	25	15.0	300	50	22	30		-6940K	6104.00
S32U PDUNR 15	32	30	15.0	350	50	22	39		-6960K	7841.00
S40V PDUNR 15	40	37	18.5	400	60	27	48		-6980K	8519.00

PSKN R

75° approach for negative square inserts.

Inserts See Group 120
 Sizes **12** = 1204__

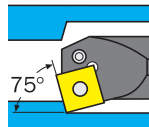
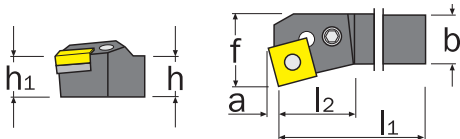

Spares to Suit Contact your local branch for prices

Shim	Shim Pin	Lever	Lever Screw				Hex Key
Order Code IND-107							Order Code KEN-601

ISO Designation	dg7	h	h1	l1	l2	f	a	Dmin	Weight each	Order Code IND-106	Price/1 TB
S25T PSKNR 12	25	23	11.5	300	40	17	3.1	31		-7020K	6420.00

PTFN R/L

90° approach for negative triangular inserts.

Inserts See Group 120
 Sizes **16** = 1604__
 Sizes **22** = 2204__

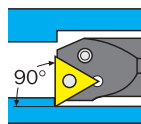
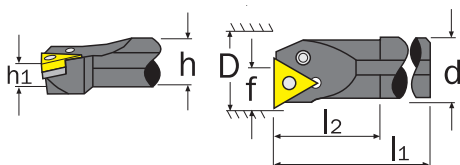

Spares to Suit Contact your local branch for prices

Shim	Shim Pin	Lever	Lever Screw				Hex Key
Order Code IND-107							Order Code KEN-601

ISO Designation	dg7	h	h1	l1	l2	f	Dmin	Weight each	Order Code IND-106	Price/1 TB
S25T PTFNR 16	25	23	11.5	300	40	17	31		-7200K	6420.00
S32U PTFNR 16	32	30	15.0	350	50	22	39		-7240K	7841.00

PRODUCTS ARE ONLY AVAILABLE VIA YOUR DISTRIBUTOR

GROUP 106 TOOLHOLDERS - ISO BORING

INDEXA-SEIKI Lever Lock Boring Bars Continued



PWLN R/L

95° approach for negative 80° Trigon inserts.



Inserts See Group 120
 Sizes **06** = 0604__
 Sizes **08** = 0804__



WN_G

CUTTING TOOLS

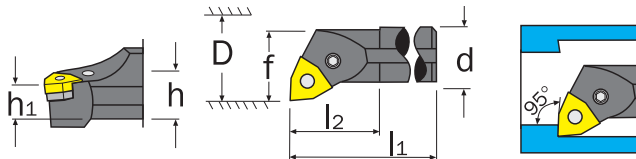

Spares to Suit Contact your local branch for prices

Shim	Shim Pin	Lever	Lever Screw					Hex Key
Order Code IND-107								
		-1000K	-1350K					Order Code KEN-601
								-1250K
	-2083K	-3050K	-1300K					-1250K
			-1500K					-1300K

ISO Designation	dg7	h	h1	l1	l2	f	Dmin	Weight each	Order Code IND-106	Price/1 TB
S16R PWLNR 06	16	15	9	200	44	10	19		-7320K	5022.00
S20S PWLNR 06	20	18	9	250	42	12	23		-7324K	5350.00
S25T PWLNR 06	25	23	15	300	45	15.5	30		-7328K	5350.00
S25T PWLNR 08	25	23	11.5	300	40	17	31		-7334K	5350.00

Screw-On Boring Bars SCLC R/L

95° approach for 7° positive 80° rhombic inserts.



Inserts See Group 120
 Sizes **06** = 0602__
 Sizes **09** = 09T3__



CC_T

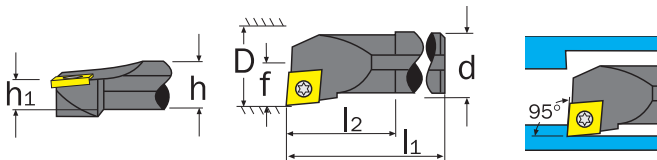

Spares to Suit Contact your local branch for prices

Insert Screw								Torx Key
Order Code IND-107								
		-3250K						-5070K
								-5070K
	-3250K							-5070K
								-5150K
		-3350K						-5150K
								-5150K
	-3350K							-5150K
								-5150K

ISO Designation	dg7	h	h1	l1	l2	f	Dmin	Weight each	Order Code IND-106	Price/1 TB
S08K SCLCR 06	8	7	3.5	125	16	5	11		-7380K	3055.00
S08K SCLCL 06	8	7	3.5	125	16	5	11		-7390K	3055.00
S10M SCLCR 06	10	9	4.5	150	25	7	13		-7400K	2946.00
S10M SCLCL 06	10	9	4.5	150	25	7	13		-7410K	2946.00
S12M SCLCR 06	12	11	5.5	150	30	9	17		-7435K	4243.00
S12Q SCLCR 09	12	11	5.5	180	30	9	17		-7440K	4243.00
S12Q SCLCL 09	12	11	5.5	180	30	9	17		-7450K	4243.00
S16R SCLCR 09	16	15	7.5	200	30	11	20		-7480K	2946.00
S16R SCLCL 09	16	15	7.5	200	30	11	20		-7490K	3055.00
S20S SCLCR 09	20	18	9	250	35	13	24		-7500K	3930.00
S20S SCLCL 09	20	18	9	250	35	13	24		-7510K	3930.00
S25T SCLCR 09	25	23	11.5	300	40	17	31		-7520K	6639.00

Screw-on Boring Bars (Through Coolant)

95° approach. Uses CCMT 06 inserts.

WITH THROUGH COOLANT

Inserts See Group 120
 Sizes **06** = 0602__



CC_T

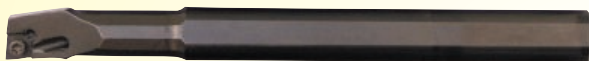

QBC-06 Quad Bore Holder Set - SCLC R

A set featuring 4 SCLCR 95° approach screw-on boring bars in 6, 8, 10 and 12mm diameter, the bars use a CCMT 06 insert. For small diameter bores on manual and CNC lathes.

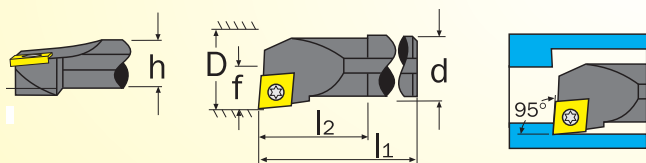

Spares to Suit Contact your local branch for prices

Insert Screw								Torx Key
Order Code IND-107								
		-5240K						-5070K

ISO Designation	dg7	h	h1	l1	l2	f	Dmin	Weight each	Order Code IND-106	Price/1 TB
A0608H SCLC 06	6	7	1.00	25	4	8			-7530K	4537.00
A0810J SCLC 06	8	9	1.10	32	6	12			-7532K	4537.00
A01012K SCLC 06	10	11	1.25	38	7	14			-7534K	4537.00
A01216M SCLCR 06	12	15	1.50	50	9	18			-7536K	4537.00
Set of all 4 above									-9980K	11253.00

INDEXA-SEIKI Screw-on Boring Bars

SDUC R/L

93° approach for 7° positive 55° rhombic inserts.



Inserts See Group 120
 Sizes **07** = 0702__
 Sizes **11** = 11T3__

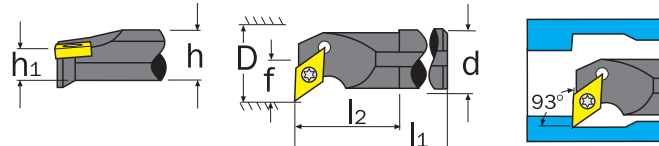

Spares to Suit Contact your local branch for prices

Order Code IND-107										
-	-3250K	-	-	-	-	-	-	-	-	-5070K
-	-3250K	-	-	-	-	-	-	-	-	-5070K
-	-3250K	-	-	-	-	-	-	-	-	-5070K
-	-3270K	-	-	-	-	-	-	-	-	-5150K
-	-3270K	-	-	-	-	-	-	-	-	-5150K

ISO Designation	dg7	h	h ₁	l ₁	l ₂	f	D _{min}	Weight each	Order Code IND-106	Price/1 TB
S12Q SDUCR 07	12	11	5.5	180	25	9	16		-7660K	4770.00
S12Q SDUCL 07	12	11	5.5	180	25	9	16		-7670K	4770.00
S16R SDUCR 07	16	15	7.5	200	30	11	20		-7680K	4770.00
S16R SDUCL 07	16	15	7.5	200	30	11	20		-7690K	4770.00
S20S SDUCR 11	20	18	9.0	250	35	13	24		-7710K	4770.00
S20S SDUCL 11	20	18	9.0	250	35	13	24		-7720K	4770.00
S20S SDUCR 11	20	18	9.0	250	35	13	24		-7730K	4770.00
S25T SDUCR 11	25	23	11.5	300	40	17	31		-7740K	4891.00
S25T SDUCL 11	25	23	11.5	300	40	17	31		-7750K	4891.00

STFC R/L

90° approach for 7° positive triangular inserts.



Inserts See Group 120
 Sizes **11** = 1102__
 Sizes **16** = 16T3__

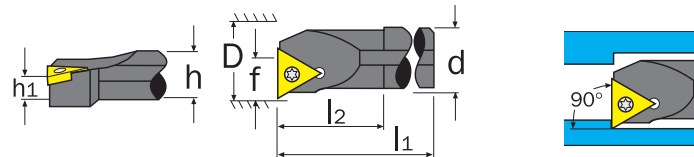

Spares to Suit Contact your local branch for prices

Order Code IND-107										
-	-3260K	-	-	-	-	-	-	-	-	-5060K
-	-3250K	-	-	-	-	-	-	-	-	-5070K
-	-3250K	-	-	-	-	-	-	-	-	-5070K
-	-3250K	-	-	-	-	-	-	-	-	-5070K
-	-3270K	-	-	-	-	-	-	-	-	-5150K

ISO Designation	dg7	h	h ₁	l ₁	l ₂	f	D _{min}	Weight each	Order Code IND-106	Price/1 TB
S10K STFCR 11	10	9	4.5	125	25	7	13		-7840K	4453.00
S12Q STFCR 11	12	11	5.5	180	25	9	16		-7880K	4453.00
S16R STFCR 11	16	15	7.5	200	30	11	20		-7920K	4453.00
S20S STFCR 11	20	18	9.0	250	35	13	24		-7940K	4453.00
S25T STFCR 16	25	23	11.5	300	40	17	31		-7955K	5678.00

Screw-On Carbide Shank Boring Bars with Through Coolant
SCLC R/L

95° approach for 7° positive 80° rhombic inserts.



Inserts See Group 120
 Sizes **06** = 0602__
 Sizes **09** = 09T3__



CARBIDE

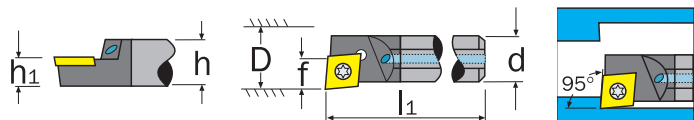

Spares to Suit Contact your local branch for prices

Order Code IND-107										
-	-3248K	-	-	-	-	-	-	-	-	-5080K
-	-3248K	-	-	-	-	-	-	-	-	-5080K
-	-3350K	-	-	-	-	-	-	-	-	-5150K

ISO Designation	r _h B	h ₁	h	l ₁	f	D _{min}	Weight each	Order Code IND-106	Price/1 TB
E10M SCLCR 06	10	5	9	150	5.5	12		-7340K	20688.00
E12M SCLCR 06	12	6	11	150	6.5	14		-7420K	22257.00
E16R SCLCR 09	16	8	14	200	8.5	18		-7460K	40214.00

PRODUCTS ARE ONLY AVAILABLE VIA YOUR DISTRIBUTOR

SWISS+BURR Modular Deburring Tools



An interchangeable system of handle, holders and blades designed to cover all hand applications of deburring. Made up of HSS and carbide blades, countersinks and scrapers along with ergonomically designed handles. This is one of the most comprehensive ranges available.

Blades are interchangeable with commonly available brands including Kennedy®, Noga®, Ruko®, Seco®, Snap-Tap® and Stellram®.

CUTTING TOOLS

Application Range

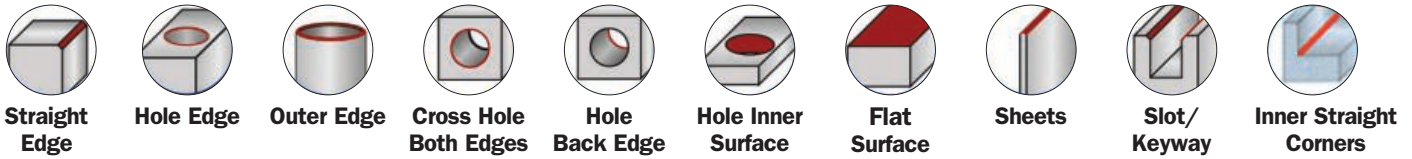

Industry Sectors

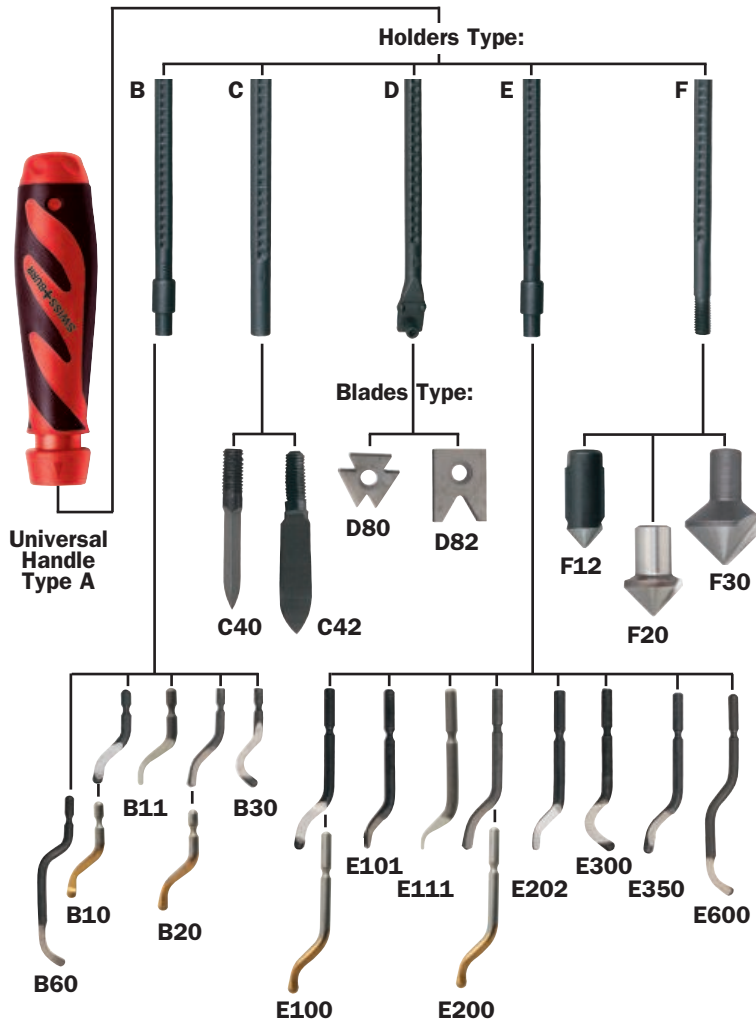
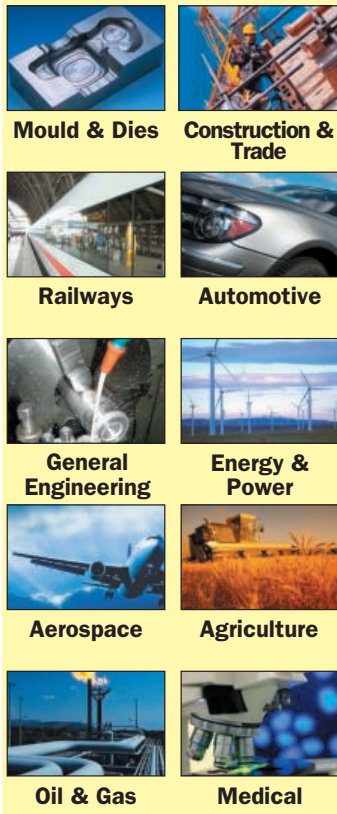

Material Range



Universal Ergonomic Handle

Modern ergonomic handle design, with an easy to use spring release mechanism. Pulling back on the locking head collar releases the telescopic blade holder for optimal length. Works with all **SWISS+BURR** holders and blades.



Type	To Suit	Weight each	Order Code SWT-109	Price/1 TB
A	B, C, D, E & F Holders	130g	-1010A	316.00

Holders

Type	Suitable For Type	Weight each	Order Code SWT-109	Price/1 TB
B	B Blades	50g	-1020B	296.00
C	C Scrapers	40g	-1200K	409.00
D	D Corner Chamfering Blades	50g	-1300R	409.00
E	E Blades	40g	-1400A	409.00
F	F Countersinks	50g	-1600P	485.00

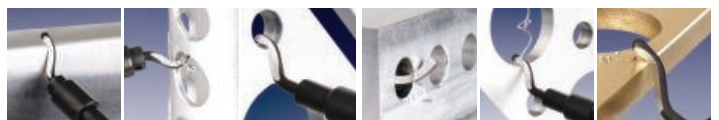

Heavy Duty Slim Grip Handle SB2000

SWISS+BURR hand deburring tools are a fast, effective and efficient way of deburring holes, slots and edges. **SWISS+BURR** is a totally modular system of interchangeable handles, holders and blades designed to cover all applications. A choice of HSS or carbide blades, countersinks and scrapers are available to suit your specific application. **SWISS+BURR** blades are also interchangeable with commonly available brands including Kennedy®, Noga®, Ruko®, Seco®, Snap-Tap® and Stellram®.



Type	Suitable for Type	Weight each	Order Code SWT-109	Price/1 TB
SB2000	E Blades		-6010A	603.00

SWISS+BURR *Modular Deburring Tools*

Application Table (by Material)

Material Blade	Steel	Aluminium	Copper	Brass	Cast Iron	Plastics	Stainless Steel	Hardened Steels
B10	•	•	•			•		
B10 TiN	•	•	•			•	•	
B10 HSSCo	•	•	•			•	•	
B11	•	•	•			•		
B20				•	•	•		
B20 TiN				•	•	•		
B30	•	•	•			•		
B60	•	•	•			•		
C40/C42	•	•		•	•	•	•	
D80/D82	•	•	•	•	•	•	•	•
E100/E101	•	•	•					
E100 TiN	•	•	•				•	•
E111	•	•	•			•		
E200/E202				•	•	•		
E200 TiN				•	•	•		
E300	•	•	•			•		
E350		•		•	•	•		
E600	•	•	•			•		
F12/F20/F30	•	•	•	•	•	•	•	
N80	•	•	•			•	•	
N80K	•	•	•	•	•	•	•	

Light Duty Blades

B10

HSS Blade for straight and hole edge deburring.



B11

B10 geometry with thin nose for small diameter holes down to 2mm.



B20

HSS Blade for straight and hole edge deburring, blade design allows clockwise and anti-clockwise movement.



B30

HSS Blade for Cross-Hole and both edges, blade will simultaneously deburr the inside and outside of the hole. For use on holes up to 4mm thick.



B60

HSS Blade for deburring back edges on holes, will remove burrs from the back edge of holes up to 20mm thick.



Type	Description	Weight each	Order Code SWT-109	Price/1 TB
B10	Steel & Aluminium	30g/10	-1030C	152.00
B10 TiN	Steel & Aluminium	30g/10	-1031B	152.00
B10 HSSCo	Steel & Aluminium	30g/10	-1031M	152.00
B11	Steel & Aluminium	30g/10	-1032C	152.00
B20 TiN	Steel & Aluminium	30g/10	-1041B	152.00
B20	Brass & Cast Iron	30g/10	-1040D	152.00
B30	Sheet & Tubing, Front & Rear Cut	20g/10	-1050E	170.00
B60	Rear Cut - Extra Length	30g/10	-1060F	195.00

DEBURRING TOOLS

Modular Deburring Tools

EXTENDED RANGE



Heavy Duty Blades

E100E100S



HSS heavy duty blade for use on straight and hole edges, for deburring materials with spiral chips. E100S has additional cobalt content for use on hardened materials.

E101



HSS heavy duty blade for use on straight and hole edges, E style shank with B10 cutting geometry, for use on materials with spiral chips and holes with minimum diameter of 2mm.

E111



HSS heavy duty blade is for straight and hole edge deburring, for use on materials with spiral chips, steel, aluminium, copper and plastic.

E200



HSS heavy duty blade for use on straight and hole edges, blade design allows clockwise and anti-clockwise movement for use on materials with powdery chips.

E202



HSS heavy duty blade for use on straight and hole edges, E style shank with B20 cutting geometry, blade design allows clockwise and anti clockwise movement for use on materials with powdery chips.

E300



HSS heavy duty blade for use on cross-hole and both edges, blade will simultaneously deburr the inside and outside of the hole up to 6mm thick. For use on materials with spiral chips.

E350



HSS heavy duty blade for use on straight and hole edges, blade design allows clockwise and anti-clockwise movement for use on materials with powdery chips.

E600



Heavy duty blade for removing burrs from the back edges of holes up to 20mm thick.

Type	Description	Weight each	Order Code SWT-109	Price/1 TB
E100	Steel & Aluminium	40g/10	-1420C	70.00
E100 TiN	Steel & Aluminium	40g/10	-1421B	137.00
E100S	Steel & Aluminium	40g/10	-1422C	155.00
E101	Steel & Aluminium, Extra Fine Point	50g/10	-1430D	83.00
E111	Steel & Aluminium	40g/10	-1431B	126.00
E200	Brass & Cast Iron	40g/10	-1440E	70.00
E200 TiN	Steel & Aluminium	40g/10	-1441B	137.00
E202	Brass & Cast Iron, Extra Fine Point	40g/10	-1450F	83.00
E300	Sheet & Tubing, Front & Rear Cut	50g/10	-1460G	70.00
E350	For Deburring Grooves	40g/10	-1480J	70.00
E600	Rear Cut - Extra Length	30g/ 5	-1500L	120.00

PRODUCTS ARE ONLY AVAILABLE VIA YOUR DISTRIBUTOR

GROUP 109 DEBURRING TOOLS

SWISS+BURR B4 Hand Deburring Set

The **SWISS+BURR™** B4 deburring set is a popular choice for deburring holes, slots and edges on metals and plastics.

The **B4 set contains: SWISS+BURR™** 1x universal handle, 1x B-holder, B10 and B20 blades.



**4
PIECES**

Number of Pieces	Description	Weight each	Order Code	Price/1 TB
4	B4 Hand Deburring Set		-5020B	818.00

B & C Standard Duty Deburring & Scraping Set

The **SWISS+BURR™** B & C Standard Duty Deburring and Scraping Set is ideal for general deburring and scraping use on holes, slots and edges.

The set contains: **SWISS+BURR™** 1x Type A universal handle, 1x Type B Blade holder, 1x B10, 1x B11, 1x B20 TiN, 1x B30, 1x B60, 1x B70 carbide tipped, 1x Type C scraper and 1x C40 triangular scraper.



**11
PIECES**

Number of Pieces	Description	Weight each	Order Code	Price/1 TB
11	B & C Deburring Set		-5021B	2678.00

E & C Heavy Duty Deburring & Scraping Set

The **SWISS+BURR™** E & C Standard Duty Deburring and Scraping Set is ideal for intense deburring and scraping use on holes, slots and edges.

The set contains: **SWISS+BURR™** 1x Type A universal handle, 1x Type C scraper, 1x C42 triangular scraper, 1x Type E blade holder, 1x E100 TiN blade, 1x E111 blade, 1x E200 blade, 1x E300 two sided blade, 1x E600 rear cutting blade and 1x E700 blade.



**11
PIECES**

Number of Pieces	Description	Weight each	Order Code	Price/1 TB
11	E & C Heavy Duty Set		-5061B	2733.00

E5 Heavy Duty Hand Deburring Set

For holes, slots and edges.

The **SWISS+BURR™** E-Type modular hand deburring system is supplied with high speed steel blades, and scrapers along with an ergonomically designed handle and blade holder.

The **E5 set contains: SWISS+BURR™** 1x universal handle, 1x E-holder, 1x E100 blade, 1x E101 blade, 1x E200 blade.



**5
PIECES**

Number of Pieces	Description	Weight each	Order Code	Price/1 TB
5	E5 Hand Deburring Set		-5050E	693.00

E7 Heavy Duty Hand Deburring Set

For holes, slots and edges.

Modern ergonomic handle design, with an easy to use spring release mechanism. Pulling back on the locking head collar releases the telescopic blade holder for optimal length.

Works with all **SWISS+BURR™** holders and blades.

The **E7 set contains: SWISS+BURR™** 1x universal handle, 1x E-holder, 1x E100 blade, 1x E101 blade, 1x E200 blade, 1x E202 blade, 1x E300 blade.



**7
PIECES**

Number of Pieces	Description	Weight each	Order Code	Price/1 TB
7	E Hand Deburring Set		-5060F	818.00

Diamond Coated Filing & Deburring Set

The set contains: **SWISS+BURR™**

1x extra close handle, 1x E100S and 1x E400 blades plus five different shaped diamond coated files: rectangular, square, triangular, round and half round.



**8
PIECES**

Number of Pieces	Description	Weight each	Order Code	Price/1 TB
8	Filing & Deburring Set		-1350Z	4371.00

CUTTING TOOLS

SWISS+BURR C3 Hand Scraper Set

Three cutting edges which when combined with a telescopic holder allow easy access to deburr small holes etc in difficult positions.

The C3 set contains: SWISS+BURR™ 1x ergonomic handle, 1x C type blade holder, and 1x C42 blade.

3
PIECES



Number of Pieces	Description	Weight each	Order Code SWT-109	Price/1 TB
3	C3 Scraper Set		-5030C	1635.00

Scraper Blades

C40 HSS Small Triangular Scraper (4.00mm)

For precision work on back edge and inner surface of holes and flat surfaces.



C42 HSS Small Triangular Scraper (8.00mm)

For precision work on back edge and inner surface of holes and flat surfaces.



Type	Description	Weight each	Order Code SWT-109	Price/1 TB
C40	Triangular 4 x 20mm	10g	-1220M	568.00
C42	Triangular 8 x 30mm	10g	-1230N	818.00

D3 Hand Deburring Set

For scraping surfaces and deburring sheet metal up to 3mm thick.

The D3 set contains: SWISS+BURR™ 1x ergonomic handle, 1x D type blade holder and 1x D80 blade.

3
PIECES



Number of Pieces	Description	Weight each	Order Code SWT-109	Price/1 TB
3	D3 Hand Deburring Set		-5040D	1698.00

Corner Chamfering Blades

D80 Solid Carbide Blade

For sheet metal and flat surfaces, for scraping surfaces and deburring sheet metal up to 3mm thick.

D82 Solid Carbide Heavy Duty Blade

With double edge for deburring sheet metal, for deburring sheet metal up to 9mm thick.



Type	Description	Weight each	Order Code SWT-109	Price/1 TB
D80	Sheet up to 3mm	5g	-1340V	661.00
D82	Sheet up to 8mm	9g	-1350W	818.00

DB3 Double Burr Hand Deburring Set

For deburring materials with single or double straight edges up to 14.00mm thick. Blade holder fitted with safety hand guard.

The DB3 set contains: SWISS+BURR™ 1x ergonomic handle, 1x blade holder and 2x N80 blades.

3
PIECES



Number of Pieces	Description	Weight each	Order Code SWT-109	Price/1 TB
3	DB3 Double Burr Hand Deburring Set		-2400K	1508.00

N80 Replacement Blade

HSS double edged round blade for straight edge and sheet metal deburring on materials with spiral chips.



Type	Description	Weight each	Order Code SWT-109	Price/1 TB
N80	Blade for Type DB3	10g/2	-2080M	490.00

DEBURRING TOOLS

F3 Hand Chamfering & Countersinking Set

For hole edges up to 20.00mm.

The F3 set contains:

SWISS+BURR™ 1x ergonomic handle, 1x F type blade holder and 1x F20 countersink.

3
PIECES



Number of Pieces	Description	Weight each	Order Code SWT-109	Price/1 TB
3	B4 Deburring Set		-5070G	2075.00

Countersinks - 90° Included Angle

F12

HSS countersink for hole edges up to 12mm dia.

F20

HSS countersink for hole edges up to 20mm dia.

F30

HSS countersink for hole edges up to 30mm dia.



Type	Description	Weight each	Order Code SWT-109	Price/1 TB
F12 (C12)	Drilled holes up to 12mm Diameter	30g/1	-1610Q	1070.00
F20 (C20)	Drilled holes up to 20mm Diameter	30g/1	-1620R	1251.00
F30 (C30)	Drilled holes up to 30mm Diameter	90g/1	-1630S	2075.00

KB3 Keyway Burr Hand Deburring Set

3 Piece Set

For deburring and cleaning edges of internal and external keyways and slots up to 15mm.

The KB3 set contains: SWISS+BURR™ 1x ergonomic handle, 1x blade holder and 1x N80K blade.

3
PIECES



Number of Pieces	Description	Weight each	Order Code SWT-109	Price/1 TB
3	KB3 Keyway Hand Deburring Set		-2500M	1163.00

N80K Replacement Blade

HSS blade with eight cutting edges for slots and keyways up to 15.00mm wide.



Number of Pieces	Description	Weight each	Order Code SWT-109	Price/1 TB
N80K	Blade for Type KB3	10g/2	-2090N	265.00

Mini Burr Set

Lightweight reinforced plastic handle with easy grip and pocket clip. Handle will hold all E style heavy duty blades, supplied with 1x E100 blade. Removable cap for blade storage.

2
PIECES



Number of Pieces	Description	Weight each	Order Code SWT-109	Price/1 TB
2	Mini Burr Set		-2600P	296.00

1 Shape

Symbol	Shape	Nose Angle	Figure
H	Hexagonal	120°	
O	Octagonal	135°	
P	Pentagonal	108°	
S	Square	90°	
T	Triangular	60°	
C	Rhombic	80°	
D		55°	
E		75°	
F		50°	
M		86°	
V		35°	
W	Trigon	80°	
L	Rectangular	90°	
A	Parallelogram	85°	
B		82°	
K		55°	
R	Round	-	

2 Relief Angle

Symbol	Relief Angle
A	3°
B	5°
C	7°
D	15°
E	20°
F	25°
G	30°
N	0
P	11°
O	Others

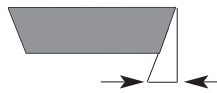

3 Accuracy

Symbol (class)	Tolerance (mm)		
	Corner Height (m)	Thickness (s)	I.C. Dia. (d)
A	±0.005	±0.025	±0.025
F	±0.005	±0.025	±0.013
C	±0.013	±0.025	±0.025
H	±0.013	±0.025	±0.013
E	±0.025	±0.025	±0.025
G	±0.025	±0.13	±0.025
J	±0.025	±0.13	±0.05 } * ±0.13 } *
K	±0.01	±0.025	±0.05 } * ±0.13 } *
L	±0.025	±0.025	±0.05 } * ±0.13 } *
M	±0.08 } * ±0.18 } *	±0.13	±0.05 } * ±0.13 } *
N	±0.08 } * ±0.18 } *	±0.025	±0.05 } * ±0.13 } *
U	±0.13 } * ±0.38 } *	±0.13	±0.08 } * ±0.25 } *

* Details of accuracy will vary according to shape and size of insert - further details are available on request.

1
T

2
N

3
M

4
G

5
16

4 Groove and Hole

Symbol	Shape of Hole	Chipbreaker	Shape
N	Without Hole	Without	
R		Single-sided	
F		Double-sided	
A	Cylindrical Hole	Without	
M		Single-sided	
G		Double-sided	
W	With partly cylindrical hole, double-side 40° - 60°	Without	
T		Single-sided	
Q	With partly cylindrical hole, double-side 40° - 60° Countersink	Without	
U		Double-sided	
B	With partly cylindrical hole, single-side 70° - 90° Countersink	Without	
H		Single-sided	
C	With partly cylindrical hole, single-side 70° - 90° Countersink	Without	
J		Double-sided	
X	Special Type		

5 Cutting Edge Length

R		S		C		W		T		D		V		K		I.C. dia. (mm)
Symbol	Length	Symbol	Length	Symbol	Length	Symbol	Length	Symbol	Length	Symbol	Length	Symbol	Length	Symbol	Length	
03	3.97	03	3.97	03	4.0	02	2.7	06	6.9	04	4.8	-	-	-	-	3.97
-	-	04	4.76	04	4.8	L3	-	08	8.2	05	5.8	-	-	-	-	4.76
05	5.0	-	-	-	-	-	-	-	-	-	-	-	-	-	-	5.0
-	-	05	5.56	05	5.6	03	3.8	09	9.6	06	6.8	-	-	-	-	5.56
06	6.0	-	-	-	-	-	-	-	-	-	-	-	-	-	-	6.0
-	-	06	6.35	06	6.5	04	4.3	11	11.0	07	7.8	-	-	-	-	6.35
-	-	07	7.94	08	8.1	05	5.4	13	13.8	09	9.7	-	-	-	-	7.94
08	8.0	-	-	-	-	-	-	-	-	-	-	-	-	-	-	8.0
09	9.525	09	9.525	09	9.7	06	6.5	16	16.5	11	11.6	16	16.6	16	19.7	9.525
10	10.0	-	-	-	-	-	-	-	-	-	-	-	-	-	-	10.0
12	12.0	-	-	-	-	-	-	-	-	-	-	-	-	-	-	12.0
12	12.7	12	12.7	12	12.9	08	8.7	22	22.0	15	15.5	22	22.1	-	-	12.70
15	15.875	15	15.875	16	16.1	10	10.9	27	27.5	19	19.4	-	-	-	-	15.875
16	16.0	-	-	-	-	-	-	-	-	-	-	-	-	-	-	16.0
19	19.05	19	19.05	19	19.3	13	13.0	33	33.0	23	23.3	-	-	-	-	19.05
20	20.0	-	-	-	-	-	-	-	-	-	-	-	-	-	-	20.0
-	-	22	22.225	22	22.6	-	-	38	38.5	27	27.1	-	-	-	-	22.225
25	25.0	-	-	-	-	-	-	-	-	-	-	-	-	-	-	25.0
25	25.4	25	25.4	25	25.8	-	-	44	44.0	31	31.0	-	-	-	-	25.4
31	31.75	31	31.75	32	32.2	-	-	55	55.0	38	38.8	-	-	-	-	31.75
32	32.0	-	-	-	-	-	-	-	-	-	-	-	-	-	-	32.0

Note: For the insert shape "K", the rule for the relationship between the symbol and the dimension differs from those of other shapes.

Detailed accuracy for **J, K, L, M, N,** and **U** classes
For inserts whose corner angle is larger than 55°

Inscribed circle	Tolerance on inscribed circle dia. (d)		Tolerance on corner height (m)		Insert Shapes applied
	J, K, L, M, N	U	J, K, L, M, N	U	
6.35	±0.05	±0.08	±0.08	±0.13	H M
9.525					O R
12.70	±0.08	±0.13	±0.13	±0.20	P
15.875	±0.10	±0.18	±0.15	±0.27	S
19.05					T
25.40	±0.13	±0.25	±0.18	±0.38	C E M

7a Edge Preparation (Milling Inserts)

Rake Angle	
A	14°
D	60°
E	75°
F	85°
P	90°
Special	

Relief Angle	
A	3°
B	5°
C	7°
D	15°
E	20°
F	25°
G	30°
N	0°
P	11°
Z	Special

Note on insert thickness
For chipbreaker inserts, the thickness is defined as 'T' (height from the bottom face to the cutting edge) shown in the figure below



6 Thickness

Symbol	Thickness
01	1.59
02	2.38
T2	2.78
03	3.18
T3	3.97
04	4.76
05	5.56
06	6.35
07	7.94
09	9.52



For D-type inserts whose corner angles are 55°

Inscribed circle	Tolerance on inscribed circle dia. (d)	Tolerance on corner height (m)	Insert Shapes applied
6.35	±0.05	±0.011	D
9.525			
12.70	±0.08	±0.15	
15.875	±0.10	±0.11	
19.05			

Note: The tolerance for shape V may be increased more than the value above.

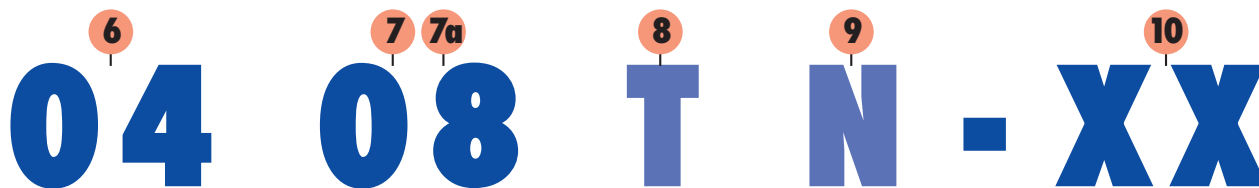

(Optional Symbols)

7 Corner Radius

Symbol	Corner Radius (mm)
00	0.03
02	0.2
04	0.4
08	0.8
12	1.2
16	1.6
20	2.0
24	2.4
28	2.8
32	3.2



Radius (Turning Inserts)

8 Symbols of major cutting edge (Milling Inserts)

Symbol	Condition of Cutting Edge	Shape
F	Sharp Edge	
E	Honed Rounded edge	
T	Chamfered edge	
S	Combination Chamfered & honed edge	

9 Hand of Insert

Symbol	Hand
R	Right
L	Left
N	Neutral

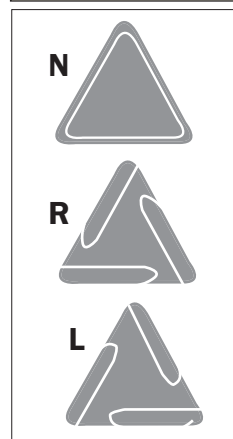

10 Chipbreaker

Chipbreakers are not part of ISO designation. Each manufacturer designates a chipbreaker in their own way.

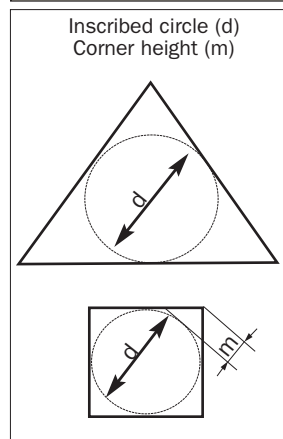

QX500 (ISO **P10-P25**) Cermet. For high speed finishing and light cutting. Will remain a high class surface finish. Mainly used on steels and can be applied to finish some Stainless steels and Cast Irons.

QX505 (ISO **K05-K15**) Coated. Used for finishing, semi finishing and medium roughing of Cast Irons including Malleable and Nodular Irons, at high speed.

QX510 (ISO **P01-P15 M10-M15 K01-K20**) Coated. Used for finishing on Steels and Stainless Steels, suitable also for turning Cast Irons including Malleable irons at high speeds.

QX5020 (ISO **P10-P35 M10-M30 K10-K30**) CVD Coated. An excellent general purpose grade for medium roughing on Steels, Stainless and Cast Irons.

QX530 (ISO **P25-P35 M15-M25**) Coated. Turning grade for Steels, Cast Steels and Stainless Steels. A good general purpose Steel grade for roughing.

QX5030 (ISO **P20-P40 M20-M30**) CVD Coated. Medium / rough turning and intermediate cutting of steel / stainless steel. Combination of toughest substrate and alumina coating (MT-TiCN + TiC + AL2O3 + TiN) having superior chipping resistance provide wide coverage.

QX535S (ISO **M10-M30**) CVD Coated. For roughing and finishing turning applications on a wide variety of Stainless Steels.

QX8010 (ISO **M10 S10**) Coated. Excellent grade giving superior results on heat resistant super alloys, especially for the aerospace industry. TiAlN based coating ensures high wear resistance on these demanding materials.

K10 (ISO **K05-K20**) Uncoated. Used in combination with a high rake geometry for matching Aluminiums, Plastics and other soft Non-Ferrous materials.

Material Group	Material Description Like Colour defines similar machineability	Brinell Hardness HB	Rockwell Hardness HRC	Tensile Strength N/mm ²	Speed - m/min										
					QX500	QX505	QX510	QX5020	QX530	QX5030	QX535S	QX8010	K10		
1.1	Mild, soft & free machining non-alloy low carbon steels	-130	-	200-400	200-270	180-300	150-350	120-200	100-200	80-200	70-200	60-200	50-200	40-200	30-200
1.2	Non-alloy, case hardening, structural & low to medium carbon steels	-200	-	180-250	180-300	150-320	120-180	100-180	80-180	70-180	60-180	50-180	40-180	30-180	
1.3	Non alloy, plain & medium carbon steels & castings	-260	-26	150-220	150-300	120-130	110-110	120-120	110-110	100-110	90-110	80-110	70-110	60-110	
1.4	Generally low to medium alloy steels & castings	-260	-26	140-210	140-250	130-210	110-140	100-140	90-140	80-140	70-140	60-140	50-140	40-140	
1.5	Medium to high alloy steels, tool steels & steel	260-340	26-48	850-1200	140-200	130-200	100-120	100-120	90-120	80-120	70-120	60-120	50-120	40-120	
1.6	Heat treated high alloy steels & castings	340-450	36-48	1200-1500	110-180	100-180	70-90	70-90	60-90	50-90	40-90	30-90	20-90	10-90	
2.1	Soft, generally easy to machine Ferritic & Martensitic steels & castings	-230	-20	800-900	90-190	110-220	70-120	170-220	80-220	80-220	70-220	60-220	50-220	40-220	
2.2	Medium, reasonable to machine Austenitic stainless steels & castings	-290	-30	1000-1600	70-160	100-220	70-140	60-100	70-120	80-120	80-120	70-120	60-120	50-120	
2.3	Hard, difficult to machine Ferritic & Austenitic (duplex) stainless & castings	-340	-36	1200	340-480	50-90	50-90	70-120	80-120	80-120	70-120	60-120	50-120	40-120	
3.1	Grey cast iron - soft to medium	-180	-	175-280	200-420	150-250	190-400								
3.2	Grey cast iron - medium to hard	180-300	-	160-250	160-340	100-180	150-300								
3.3	Malleable & Nodular iron - soft to medium	-220	-	175-280	110-300	150-250	120-250								
3.4	Malleable & Nodular irons - medium to hard	220-300	-	160-250	100-280	100-180	100-200								
4.1	Pure Titanium (also pure Nickel)													30-70	
4.2	Titanium alloys of a medium & hard nature													30-70	
4.3	Titanium alloys of a hard & very hard nature													30-50	
5.1	Heat resistant super alloys including iron based high temperature alloys													30-50	
5.2	Heat resistant super alloys, cobalt or nickel based, medium to hard to machine													30-50	
5.3	Heat resistant super alloys, cobalt or nickel based, hard or very hard to machine													30-50	
6.1	Copper			-500	200-250									200-500	
6.2	Brass (Alpha - long chip)			-800	200-250									200-500	
6.3	Brass (Beta - short chip) & soft Bronze			-800	200-250									100-500	
6.4	High strength Bronze			-1200											
7.1	Unalloyed: Aluminium, Magnesium & Zinc			-150	300-500									400-700	
7.2	Aluminium alloys less than 5% Si Magnesium & Zinc alloys (long chip)			150-300	300-500									400-700	
7.3	Aluminium alloys 5% to 10% Si			200-500	300-500									400-600	
7.4	Aluminium alloys above 10% Si (short chip)			200-500										300-500	
8.1	Thermoplastics													400-700	
8.2	Thermo-setting plastics													400-700	
8.3	Reinforced plastics & composite materials													200-500	

AL - High positive breaker specifically for aluminium alloys.

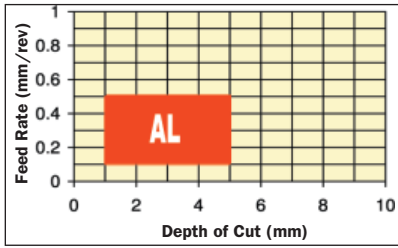
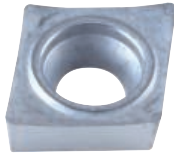

NM6 - General application medium breaker used on negative inserts with tougher grades.

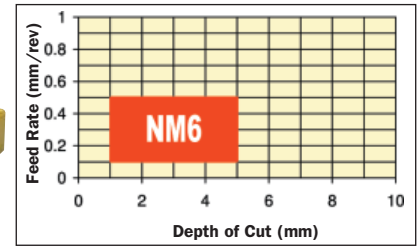
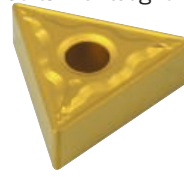

L11 / R11 - General purpose breaker for copy turning.

(A): 05 L/R11.
(B): 10 L/R11.

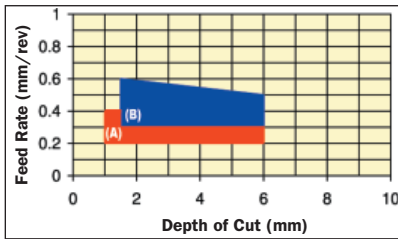

NM7 - A ripple edge breaker ideal for copy turning where cut depth varies and chip control is very important. Use with grade QX520 on steels, stainless and malleable irons.

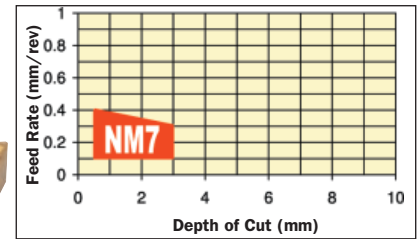

NF1 - Finishing breaker used on small VNMG 12 inserts.

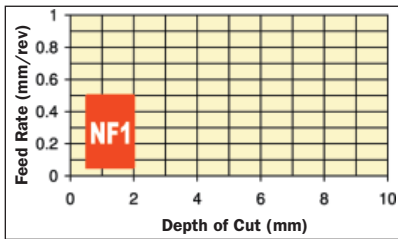

NR8 - Roughing breaker for steels and stainless with grades QX520.

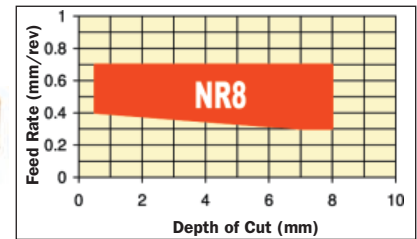

NF2 - A finishing chipbreaker associated with QX500 cermet will provide excellent surface finishes at high speeds on the majority of ferrous materials.

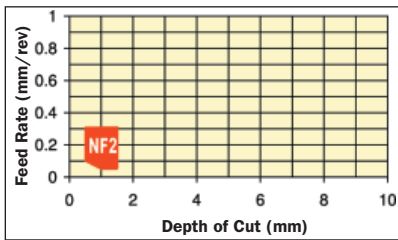
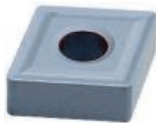

NR9 - General application roughing breaker, suitable for intermittent cuts on negative inserts.

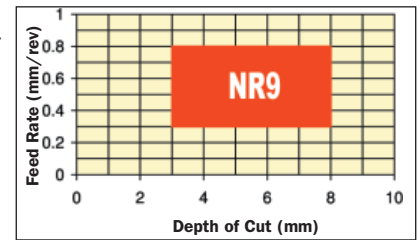
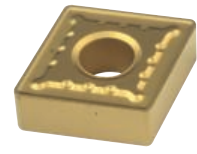

NF3 - Finishing chipbreaker for negative inserts used with QX510 for finishing steel or finish and medium cutting on cast iron.

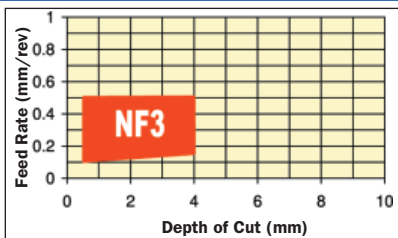
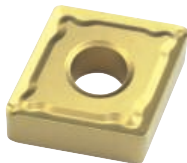

PG - General application finishing and light to medium roughing in conjunction with SPMR and TPMPR positive inserts.

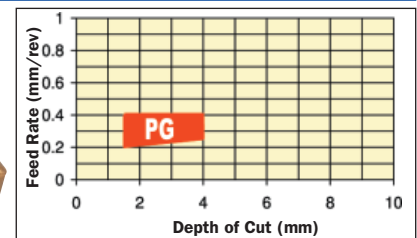
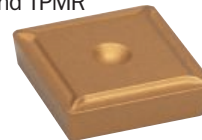

NM4 - Medium breaker used on negative inserts for light to medium roughing.

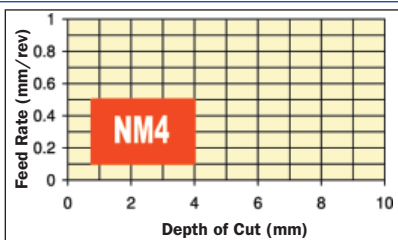
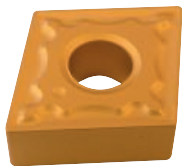

PF - Finishing breaker used on positive inserts for general application.

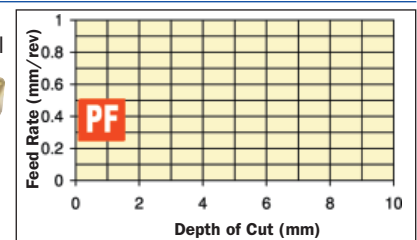

NM5 - General chipbreaker for medium roughing or semi finishing on steels and stainless in combination with grades QX510 and QX520.

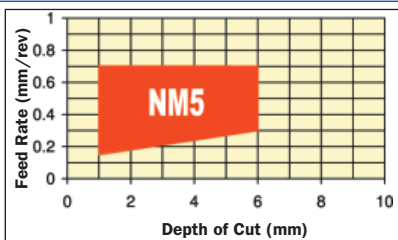

PM - Medium breaker used on positive inserts for general application.

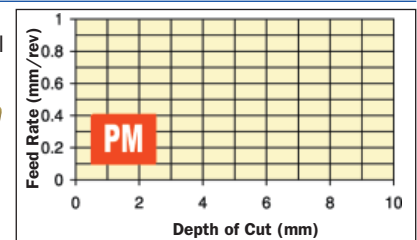
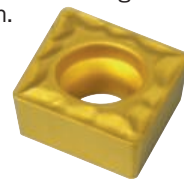

VF - General purpose chipbreaker with a radius groove, used with negative inserts. For light to medium cutting across a wide application band.

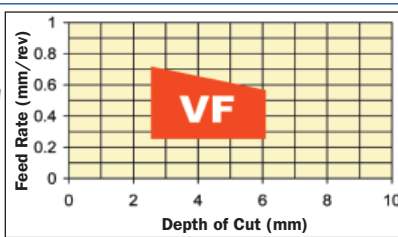

ST - Light to medium roughing breaker used in conjunction with QX535S grade for turning stainless steels.

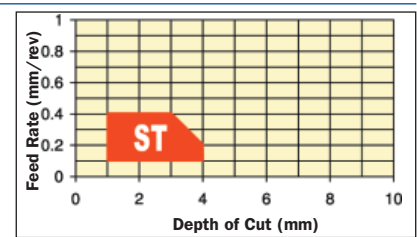

KNUX

Chip Breaker	Application
R11	Rough



Grade	ISO Designation			P	M	K	N	S	H
	P	M	K						
QX520	10 - 35	10 - 30	10 - 30	✓	✓	✓			
QX530	20 - 40	20 - 30	-	✓	✓				

Suitable for External Toolholders:

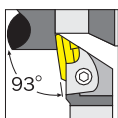

CKJN-

Insert Size	Chip-breaker	Grade	Order Code YML-120	Price/1 TB
160405	R11	QX520	-2213D	541.00
	R11	QX530	-2213E	541.00

SCGT

Chip Breaker	Application
AL	Medium (Alum)

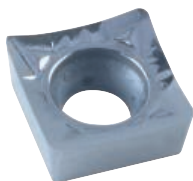

Grade	ISO Designation			P	M	K	N	S	H
	P	M	K						
K10	-	-	05 - 20						✓

Suitable for External Toolholders:

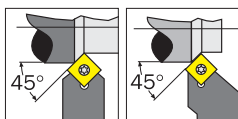

SSDC- SSSC-

Insert Size	Chip-breaker	Grade	Order Code YML-120	Price/1 TB
09T308	AL	K10	-4169N	397.00

SCMT

Chip Breaker	Application
PM	Medium



Grade	ISO Designation			P	M	K	N	S	H
	P	M	K						
QX520	10 - 35	10 - 30	10 - 30	✓	✓	✓			

Suitable for External Toolholders:

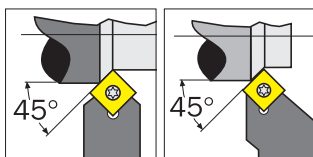

SSDC- SSSC-

Insert Size	Chip-breaker	Grade	Order Code YML-120	Price/1 TB
09T304	PM	QX520	-0425D	371.00

SNMG

Chip Breaker	Application
NM6	Med Cut
NM7	Med/Rough
NR8	Rough



Grade	ISO Designation			P	M	K	N	S	H
	P	M	K						
QX510	01 - 15	10 - 15	01 - 20	✓	✓				
QX520	10 - 35	10 - 30	10 - 30	✓	✓	✓			
QX530	20 - 40	20 - 30	-	✓	✓				
QX5030	25 - 35	15 - 25	-	✓	✓				
QX535S	-	10 - 30	-	✓					

Suitable for Internal/External Toolholders:

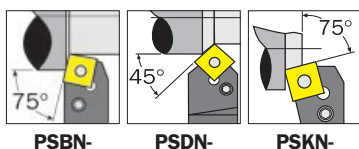

PSBN- PSDN- PSKN-

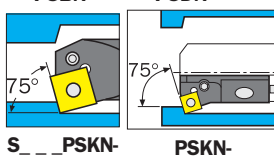

S__PSKN- PSKN-

Insert Size	Chip-breaker	Grade	Order Code YML-120	Price/1 TB
120404	NM7	QX520	-5293D	446.00
	NM6	QX5030	-5336H	446.00
120408	NM7	QX520	-5340D	446.00
	NR8	QX520	-5339D	446.00

SPMR

Chip Breaker	Application
PG	Medium



Grade	ISO Designation			P	M	K	N	S	H
	P	M	K						
QX520	10 - 35	10 - 30	10 - 30	✓	✓	✓			
QX530	20 - 40	20 - 30	-	✓	✓				
QX5020	10 - 35	10 - 30	10 - 30	✓	✓	✓			
QX5030	25 - 35	15 - 25	-	✓	✓				

Suitable for Internal/External Toolholders:

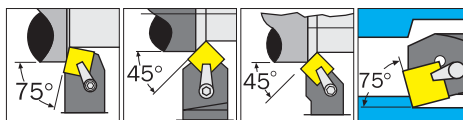

CSBP- CSDP- CSSP- S__CSKP

Insert Size	Chip-breaker	Grade	Order Code YML-120	Price/1 TB
120304	PG	QX520	-6642D	409.00
120308	PG	QX5020	-6662G	409.00
	PG	QX5030	-6662H	409.00



TCGT

Chip Breaker	Application
PF	Finish
AL	Medium

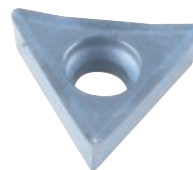

Grade	ISO Designation			P	M	K	N	S	H
	P	M	K						
K10	-	-	05 - 20						✓
QX520	10 - 35	10 - 30	10 - 30	✓	✓	✓			
QX5020	10 - 35	10 - 30	10 - 30	✓	✓	✓			

Suitable for Internal/External Toolholders:

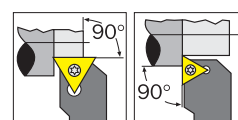

STFC- STGC-

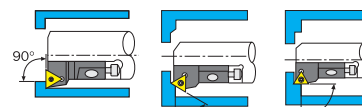

STFC- STTC- STGC-

Insert Size	Chip-breaker	Grade	Order Code YML-120	Price/1 TB
110202	AL	K10	-6931N	419.00
110204	AL	K10	-6941N	419.00
16T304	PF	QX5020	-7073G	582.00
	AL	K10	-6971N	582.00
16T308	AL	K10	-6981N	582.00

TCMT

Chip Breaker	Application
PM	Med Cut



Grade	ISO Designation			P	M	K	N	S	H
	P	M	K						
QX500	10 - 25	-	-	✓	✓	✓			
QX520	10 - 35	10 - 30	10 - 30	✓	✓	✓			

Suitable for Internal/External Toolholders:

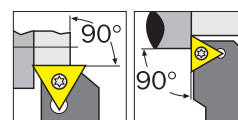

STFC- STGC-

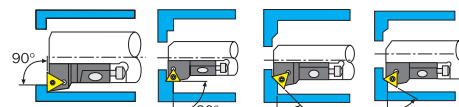

STFC- STGC- STSC- STTC-

Insert Size	Chip-breaker	Grade	Order Code YML-120	Price/1 TB
090204	PM	QX5020	-7110G	285.00
110204	PM	QX500	-7120A	285.00
	PM	QX520	-7120D	285.00
16T304	PM	QX500	-7140A	409.00
	PM	QX5020	-7140G	409.00
16T308	PM	QX5020	-7145G	409.00

TNMG

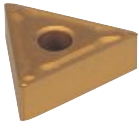

Chip Breaker	Application
NF3	Finish
NM5	Med Cut
NM6	Med Cut
NM7	Med Cut
NR8	Rough
NR9	Rough

Grade	ISO Designation			P	M	K	N	S	H
	P	M	K						
QX500	10 - 25	-	-	✓	✓	✓			
QX520	10 - 35	10 - 30	10 - 30	✓	✓	✓			
QX5030	25 - 35	15 - 25	-	✓	✓	✓			
QX535S	-	10 - 30	-	✓					

Suitable for Internal/External Toolholders:

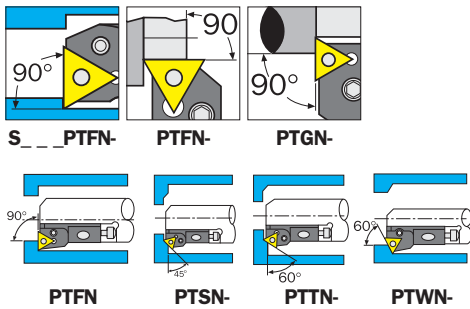

Insert Size	Chip-breaker	Grade	Order Code YML-120	Price/1 TB
160404	NM5	QX520	-7519D	346.00
	NM6	QX5030	-7516H	316.00
	NM7	QX520	-7518D	377.00
160408	NF3	QX520	-7527D	377.00
	NM5	QX520	-7529D	371.00
	NM6	QX5030	-7526H	316.00
220408	NM7	QX520	-7528D	377.00
	NM5	QX520	-7562D	504.00

TPMR



Chip Breaker	Application
PG	Med/Cut

Grade	ISO Designation			P	M	K	N	S	H
	P	M	K						
QX520	10 - 35	10 - 30	10 - 30	✓	✓	✓			
QX530	20 - 40	20 - 30	-	✓	✓	✓			
QX5020	10 - 35	10 - 30	10 - 30	✓	✓	✓			
QX5030	25 - 35	15 - 25	-	✓	✓	✓			

Suitable for Internal/External Toolholders:

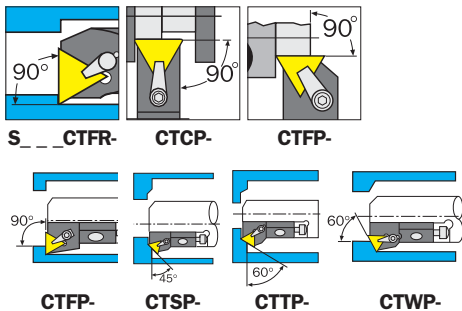

Insert Size	Chip-breaker	Grade	Order Code YML-120	Price/1 TB
110304	PG	QX5020	-8742G	371.00
	PG	QX5030	-8742H	371.00
160304	PG	QX520	-8772D	438.00
	PG	QX530	-8772E	438.00
160308	PG	QX520	-8782D	438.00
	PG	QX5030	-8782H	438.00

VCGT



Chip Breaker	Application
AL	Med Cut

Grade	ISO Designation			P	M	K	N	S	H
	P	M	K						
K10	-	-	05 - 20	✓					

Suitable for External Toolholders:

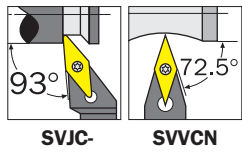

Insert Size	Chip-breaker	Grade	Order Code YML-120	Price/1 TB
110302	AL	K10	-9101N	514.00
110304	AL	K10	-9111N	514.00
160404	AL	K10	-9141N	541.00
160408	AL	K10	-9151N	567.00
160412	AL	K10	-9161N	593.00

VNMG

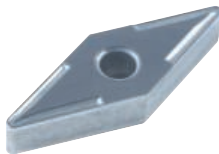

Chip Breaker	Application
NFI	Finish
VF	Finish

Grade	ISO Designation			P	M	K	N	S	H
	P	M	K						
QX500	10 - 25	-	-	✓	✓	✓			
QX520	10 - 35	10 - 30	10 - 30	✓	✓	✓			
QX530	20 - 40	20 - 30	-	✓	✓	✓			
QX5030	25 - 35	15 - 25	-	✓	✓	✓			

Suitable for External Toolholders:

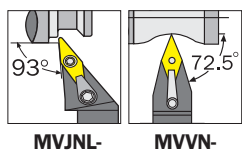

Insert Size	Chip-breaker	Grade	Order Code YML-120	Price/1 TB
12T302	NFI	QX530	-9402E	479.00
12T304	NFI	QX500	-9404A	552.00
	NFI	QX530	-9404E	552.00
12T308	NFI	QX5030	-9408H	567.00
160404	VF	QX520	-9415D	613.00

WCMX



Chip Breaker	Application
N/A	

Grade	ISO Designation			P	M	K	N	S	H
	P	M	K						
QZ820	10 - 30	10 - 30	10 - 30	✓	✓	✓			
QZ825	20 - 30	10 - 30	10 - 30	✓	✓	✓			
QZ830	05 - 30	-	-	✓	✓				

Suitable for Indexable Drills:



Insert Size	Chip-breaker	Grade	Order Code YML-120	Price/1 TB
050308	-	QZ820	-9510G	493.00
06T308	-	QZ830	-9540J	520.00
080412	-	QZ830	-9580J	520.00

WNMG



Chip Breaker	Application
NSS	Light/Medium
NM4	Med Cut
NM5	Med Cut
NM6	Med Cut

Grade	ISO Designation			P	M	K	N	S	H
	P	M	K						
QX510	01 - 15	10 - 15	01 - 20	✓	✓	✓			
QX520	10 - 35	10 - 30	10 - 30	✓	✓	✓			
QX5030	25 - 35	15 - 25	-	✓	✓	✓			
QX535S	-	10 - 30	-	✓	✓	✓			
QX8010	10	10	10	✓	✓	✓			

Suitable for Internal/External Toolholders:

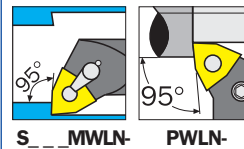

Insert Size	Chip-breaker	Grade	Order Code YML-120	Price/1 TB
060404	NM4	QX520	-9774D	384.00
060408	NSS	QX8010	-9780K	384.00
080404	NM5	QX520	-9827D	498.00
080408	NM6	QX5030	-9836H	409.00

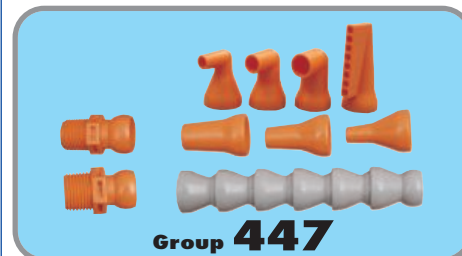

Insert Geometry for Finishing & Semi-finishing of Aluminium & Aluminium Alloys

- Optimised edge and radius geometry.
- Improved surface finish.
- Improved chip control.
- 'G' Tolerance for high repeatability.
- First choice for machining pure aluminium.
- 30% longer insert life compared to uncoated grade.

NEW

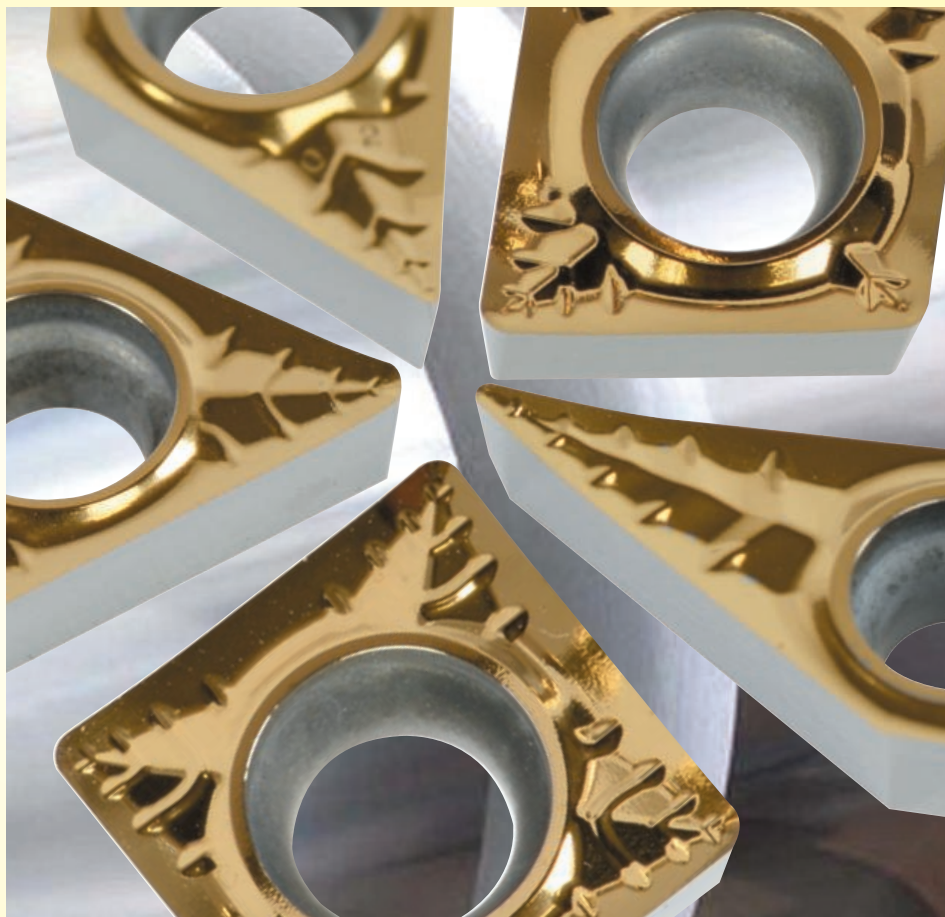

Grade K10C

ISO N05-N15 PVD Coated. Micrograin carbide for machining aluminium and aluminium alloys, 30% higher tool life against uncoated grade. Smooth coating and polished surface gives better chip control.

ALC Geometry

For finishing and semi finishing of aluminium and aluminium alloys. A unique breaker design gives a sharp cutting edge and positive rake angle. Special edge preparation and surface treatment produce better surface quality and greater chip control, reduced friction and vibration. 'G' tolerance inserts for higher repeatability.

Feed Rates

For Machining Pure Aluminium

Ap. DOC = 0.02 ~ 4.80 (mm)
F = 0.05~0.50 (mm/r)

For Machining Aluminium Alloys

Ap. DOC = 0.02 ~ 3.50 (mm)
F = 0.05~0.40 (mm/r)

30% LONGER INSERT LIFE COMPARED TO UNCOATED GRADE

DCGX

Fits the same Internal/External Toolholders as DCGT

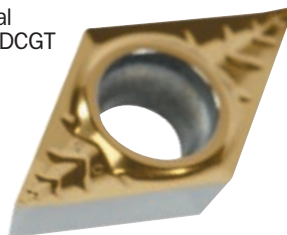

Insert Size	Chip-breaker	Grade	Order Code YML-120	Price/1 TB
070204	ALC	K10C	-1282N	361.00
11T304	ALC	K10C	-1291N	361.00

TCGX

Fits the same Internal/External Toolholders as TCGT



Insert Size	Chip-breaker	Grade	Order Code YML-120	Price/1 TB
16T308	ALC	K10C	-7096N	603.00

CCGX

Fits the same Internal/External Toolholders as CCGT

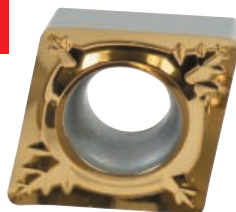

Insert Size	Chip-breaker	Grade	Order Code YML-120	Price/1 TB
060202	ALC	K10C	-0312N	361.00
060204	ALC	K10c	-0314N	361.00
09T304	ALC	K10C	-0318N	387.00
09T308	ALC	K10C	-0320N	438.00
120404	ALC	K10C	-0324N	438.00
120408	ALC	K10C	-0326N	464.00

SCGX

Fits the same Internal/External Toolholders as SCGT

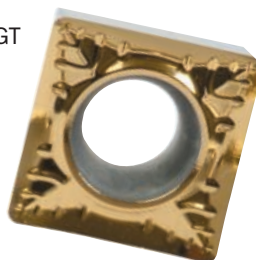

Insert Size	Chip-breaker	Grade	Order Code YML-120	Price/1 TB
120408	ALC	K10C	-4173N	411.00

VCGX

Fits the same Internal/External Toolholders as VCGT



Insert Size	Chip-breaker	Grade	Order Code YML-120	Price/1 TB
110302	ALC	K10C	-9201N	464.00
110304	ALC	K10C	-9203N	490.00
160404	ALC	K10C	-9233N	541.00

Q-Series

Think Positive!

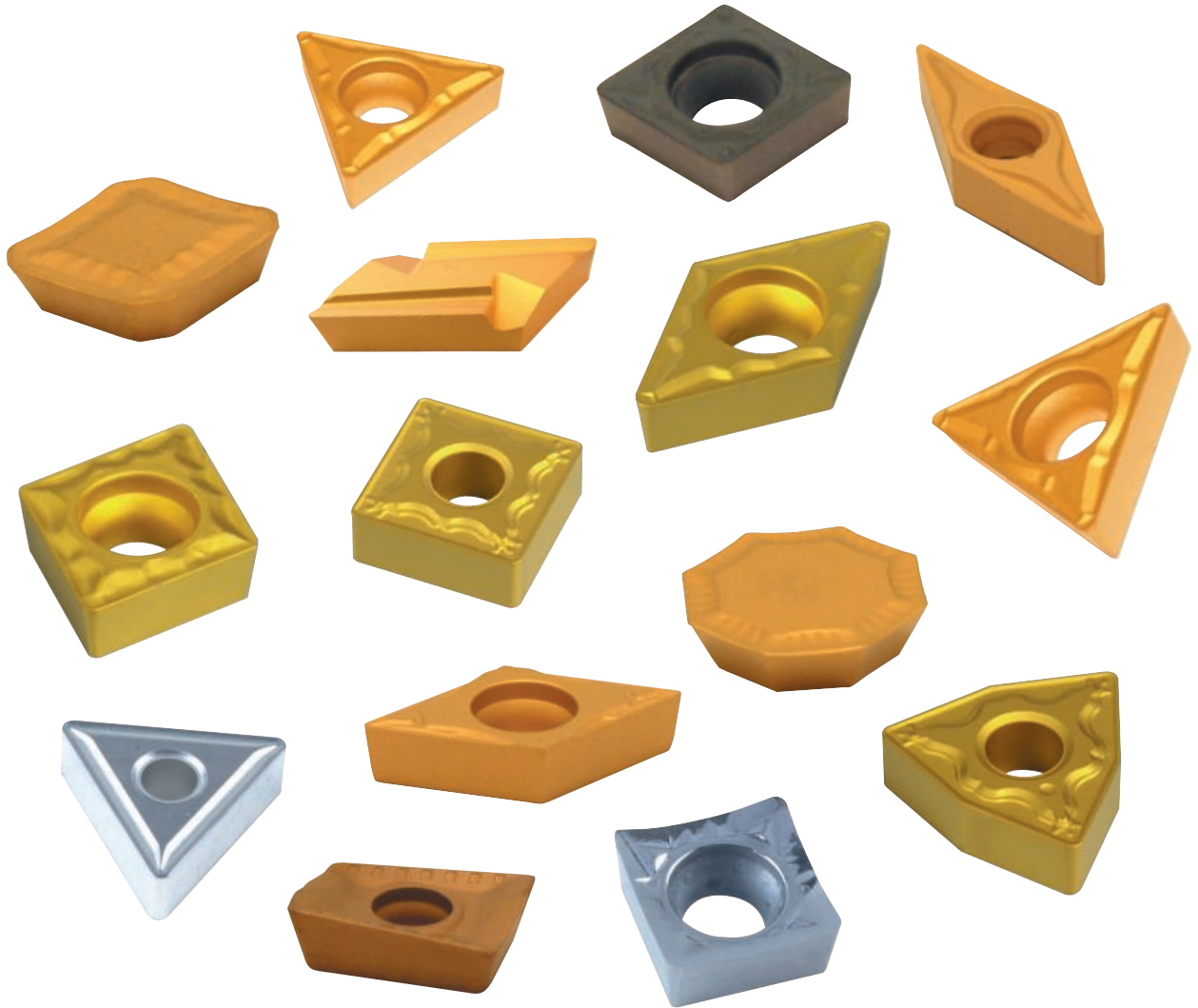

QX500 P10 - P25	QX505 K05 - K15	QX510 P01-15,M10-15,K01-20	QX520 P10-35,M10-30,K10-30	QX530 P20 - 40, M20 - 30	QX5355 M10 - M30			
QC10 K10	QK25C K15 - K30	QM10 P10 - M10, K10	QP25 P25	QP25C P10 - P35	QP30P P10 - P35	QP40 P40	QS20 P20	QX500 P10 - P25
QX520 P10-35,M10-30,K10-30							QX530 P20-40, M20-30	

...and Negative!

YAMALOY
YAMALOY TOOLING • JAPAN

High Performance Carbide Tooling
Turning - Milling - Boring - Drilling

Insert Grade

K20 **K20** Micrograin uncoated. For cast iron, aluminium alloy, other non-ferrous materials including titanium and nickel alloy.

QK25C **QK25C (K15 - K30)** Coated. For milling cast irons.

QM3535 **QM3535 (P20 - P35)** PVD TiAlN Coated for milling of steel. Comprehensive grade which covers wide application range due to substrate providing optimal wear resistance and toughness.

QP25 **QP25 (P25)** Uncoated. For medium and finish milling of steels.

QP25C **QP25C (P10 - P35)** CVD coated. Milling grade for steel and some stainless steels.

QP30P **QP30P (P10 - P35)** PVD Coated. Milling grade for steel and some stainless steels.

QP30T **QP30T (P10 - P35)** PVD Coated. Milling grade for steel and some stainless steels.

QP40 **QP40 (P40)** Uncoated. For rough medium and finish milling of tough Steels and Stainless Steels including interrupted cutting.

QX530 **QX530 (P20 - P40, M20 - M30)** Coated. A good general purpose steel grade for roughing. Use on steels, cast steel and stainless steel.

Chipbreaker

Chip Breaker	Application
AL	Aluminium & non Ferrous (Polished)
EM	Medium
MF	Finish/Light
MM	Medium/Light Roughing

APKT

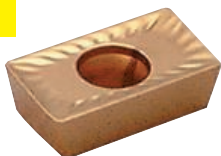

Insert Size APKT	Chip-breaker	Grade	Order Code YML-120	Price/1 TB
1003PDR	EM	QK25C	-0028X	409.00
	EM	QP30P	-0028W	346.00
1604PDR	AL	K10	-0029K	547.00
1604PDTR	-	QP30P	-0030W	441.00
	-	QK25C	-0030X	597.00
	-	K20	-0031V	409.00

SEHT



Insert Size SEHT	Chip-breaker	Grade	Order Code YML-120	Price/1 TB
1204AFTN	-	K20	-4430V	446.00
1204AFTN	-	QP25C	-4430W	629.00
120408	-	QP25C	-4432W	755.00

SEMN

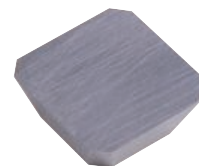

Insert Size SEMN	Chip-breaker	Grade	Order Code YML-120	Price/1 TB
1204-AZ	-	QM3535	-4727M	438.00

OFKR



Insert Size OFKR	Chip-breaker	Grade	Order Code YML-120	Price/1 TB
05T308	MF	QP25C	-2388W	1038.00

SEHW

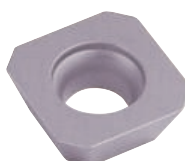

Insert Size SEHW	Chip-breaker	Grade	Order Code YML-120	Price/1 TB
1204AFTN05	-	K20	-4445V	629.00
	-	QP25C	-4445W	629.00

SNKN



Insert Size SNKN	Chip-breaker	Grade	Order Code YML-120	Price/1 TB
1204-ENN	-	QP25	-5227P	438.00

OFKT



Insert Size OFKT	Chip-breaker	Grade	Order Code YML-120	Price/1 TB
05T308-SN	MM	QP25C	-2384W	1038.00

SEKN

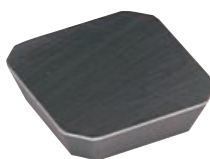

Insert Size SEKN	Chip-breaker	Grade	Order Code YML-120	Price/1 TB
1203AFFN	-	K20	-4517V	410.00
1203AFSN	-	QM3535	-4527M	531.00
1203AFTN	-	QP25	-4527P	531.00
	-	QP40	-4527S	531.00

SPKN



Insert Size SPKN	Chip-breaker	Grade	Order Code YML-120	Price/1 TB
1203EDR	-	K20	-6328V	384.00
	-	QM3535	-6338M	478.00
1203EDTR	-	QP25	-6338P	505.00
	-	QP40	-6338S	505.00
1504EDTR	-	QP25	-6368P	691.00

SDMT



Insert Size SDMT	Chip-breaker	Grade	Order Code YML-120	Price/1 TB
12T308	-	QX530	-4280E	472.00

SEKR



Insert Size SEKR	Chip-breaker	Grade	Order Code YML-120	Price/1 TB
1203AFTN05	-	K20	-4617V	593.00
	-	QP25C	-4627W	593.00

TPKN

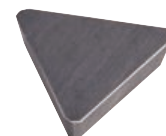

Insert Size TPKN	Chip-breaker	Grade	Order Code YML-120	Price/1 TB
1603PPR	-	K20	-8428V	411.00
	-	QM3535	-8438M	411.00
1603PPTR	-	QP25	-8438P	411.00
	-	QP40	-8438S	411.00
2204PDR	-	K20	-8458V	567.00
2204PDSR	-	QM3535	-8468M	567.00
2204PDTR	-	QP25	-8468P	567.00
	-	QP40	-8468S	567.00

GROUP 121 INDEXABLE THREADING

INDEXA-SEIKI Threading Toolholders - Dual Top Clamp & Screw-on

Example shows DIR - Internal, but clamping is identical to DER/L - External. Standard Helix is 1.5°.



CUTTING TOOLS

External

Dual DER/L - External.

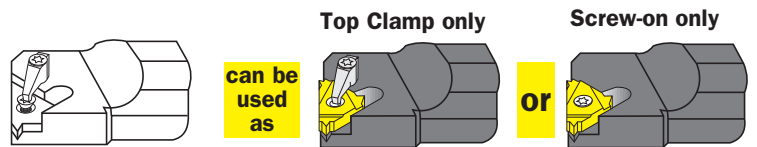
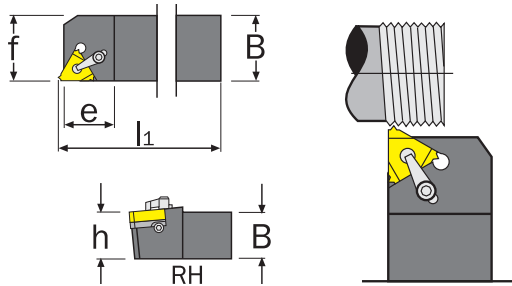

Suitable Inserts See Next Page

ER = Right Hand EL = Left Hand

Sizes 16 = 16ER/L
22 = 22ER/L



Spares to Suit

Clamp Set		Anvil		Shim Screw		Insert Screw		Torx Key	
Order Code	Price/1 TB	Order Code	Price/1 TB	Order Code	Price/1 TB	Order Code	Price/1 TB	Order Code	Price/1 TB
IND-107	957.00	IND-107	713.00	IND-107	3780K	IND-107	3430K	IND-107	5090K
0620K	957.00	2930K	713.00	3780K	90.00	3430K	110.00	5090K	126.00
0620K	957.00	2930K	713.00	3780K	90.00	3430K	110.00	5090K	126.00
0620K	957.00	2960K	651.00	3780K	90.00	3430K	110.00	5150K	73.00
0620K	957.00	2930K	713.00	3780K	90.00	3430K	110.00	5090K	126.00
0620K	957.00	2960K	651.00	3780K	90.00	3430K	110.00	5150K	73.00
0620K	957.00	2930K	713.00	3780K	90.00	3430K	110.00	5090K	126.00
0620K	957.00	2960K	651.00	3780K	90.00	3430K	110.00	5150K	73.00
0630K	1143.00	2940K	713.00	3790K	105.00	3440K	170.00	5150K	170.00

Internal

Dual DIR - Internal.

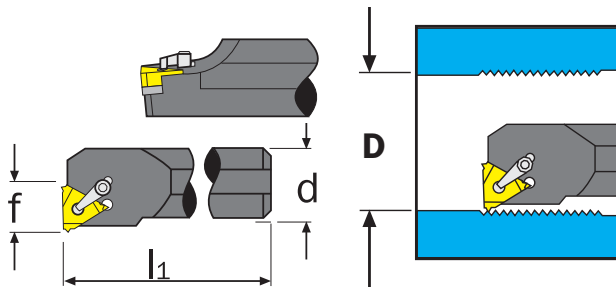

Suitable Inserts See Next Page

IR = Right Hand

Sizes 16 = 16IR
22 = 221R



Spares to Suit

Clamp Set		Anvil		Shim Screw		Insert Screw		Torx Key	
Order Code	Price/1 TB	Order Code	Price/1 TB	Order Code	Price/1 TB	Order Code	Price/1 TB	Order Code	Price/1 TB
IND-107	957.00	IND-107	651.00	IND-107	3780K	IND-107	3430K	IND-107	5090K
0620K	957.00	2960K	651.00	3780K	90.00	3430K	110.00	5090K	126.00
0620K	957.00	2960K	651.00	3780K	90.00	3430K	110.00	5100K	274.00
0620K	957.00	2960K	651.00	3780K	90.00	3430K	110.00	5090K	126.00
0630K	1143.00	2980K	833.00	3790K	105.00	3440K	170.00	5150K	73.00
0630K	1143.00	2980K	833.00	3790K	105.00	3440K	170.00	5150K	73.00

Screw-on

SIR/L - Internal.

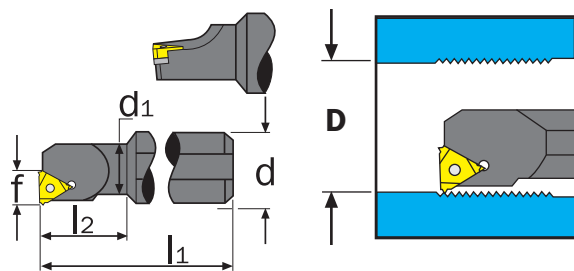

Suitable Inserts See Next Page

IR = Right hand IL = Left Hand

Sizes 06 = 06IR/L
08 = 08IR/L
11 = 11IR/L
16 = 16IR/L
22 = 22IR/L



Spares to Suit

Insert Screw		Torx Key	
Order Code	Price/1 TB	Order Code	Price/1 TB
IND-107	110.00	IND-107	5080K
3419K	110.00	5070K	73.00
3420K	110.00	5150K	73.00
3420K	110.00	5150K	73.00
3430K	110.00	5150K	73.00
3430K	110.00	5150K	73.00
3430K	110.00	5150K	73.00
3440K	170.00	5200K	126.00

ISO Designation	Dimensions							Weight each	Order Code IND-106	Price/1 TB	Order Code IND-107	Price/1 TB	Order Code IND-107	Price/1 TB
	d	d1	l1	l2	f	DMin								
SIR 0007K	08	16	6.6	125	18	5.3	7.8	174g	-8350K	4510.00	-3419K	110.00	-5080K	247.00
SIR 0010H	11	10	10	100	-	7.4	12.0	160g	-8360K	4881.00	-3420K	110.00	-5070K	73.00
SIR 0010K	11	16	10	125	25	7.4	12.0	175g	-8380K	4881.00	-3420K	110.00	-5150K	73.00
SIL 0010K	11	16	10	125	25	7.4	12.0	172g	-8390K	4881.00	-3420K	110.00	-5150K	73.00
SIR 0013M	16	16	13	150	32	10.2	16.0	217g	-8400K	4881.00	-3430K	110.00	-5150K	73.00
SIR 0016P	16	20	16	170	40	11.7	19.0	369g	-8420K	4881.00	-3430K	110.00	-5150K	73.00
SIL 0016P	16	20	16	170	40	11.7	19.0	364g	-8430K	4881.00	-3430K	110.00	-5150K	73.00
SIR 0020P	22	20	20	170	-	15.6	24.0	406g	-8440K	5040.00	-3440K	170.00	-5200K	126.00

YAMALOY *ISO Threading Insert Designation*
YAMALOY TOOLING - JAPAN

Insert Grade Description

QMA (P20-P40/K20-K30) Coated.

Sintered chipbreaker with a multi layer TiAlN PVD coated sub-micrograin grade. Provides high quality threads for most materials including exotic alloys and stainless steels. Best performance is achieved at medium to high cutting speeds.

16 ER 12 UN QMA

L

06	5/32"
08	3/16"
11	1/4"
16	3/8"
22	1/2"
27	5/8"
33	3/4"

I.C.
E= EXTERNAL
I= INTERNAL

R= RIGHT HAND
L = LEFT HAND

FULL PROFILES:
Pitch in mm:
0.35 - 8
or TPI
(Threads per inch)
64 - 4

ISO
UN
WHIT
NPT
NPTF
BSPT

CARBIDE GRADE

PARTIAL PROFILES
A N
G 60
AG 55

Partial Profiles
Internal Right Hand

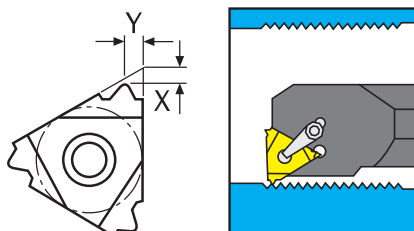

60°

Insert Designation	Pitch Range mm	TPI	X mm	Y mm	Grade	Weight per 10	Order Code YML-121	Price/1 TB
16 IR AG60	0.5-3.0	48-8	1.2	1.7	QMA	60g	-0208A	742.00

ISO Metric

External Right Hand

11 ER available on request.

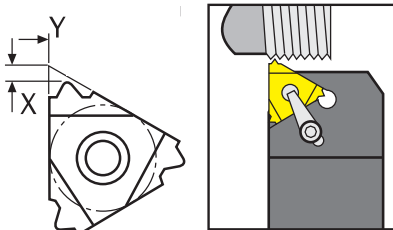

Insert Designation	TPI	X mm	Y mm	Grade	Weight per 10	Order Code YML-121	Price/1 TB
16 ER 1.00 ISO	1.00	0.7	0.7	QMA	70g	-1044Y	742.00
16 ER 1.25 ISO	1.25	0.8	0.9	QMA	70g	-1045J	742.00
16 ER 1.50 ISO	1.50	0.8	1.0	QMA	70g	-1045U	742.00
16 ER 1.75 ISO	1.75	0.9	1.2	QMA	65g	-1046E	742.00
16 ER 2.00 ISO	2.00	1.0	1.3	QMA	60g	-1046Q	742.00
16 ER 2.50 ISO	2.50	1.1	1.5	QMA	60g	-1047A	742.00
16 ER 3.00 ISO	3.00	1.2	1.6	QMA	60g	-1047L	742.00

ISO Metric

Internal Right Hand

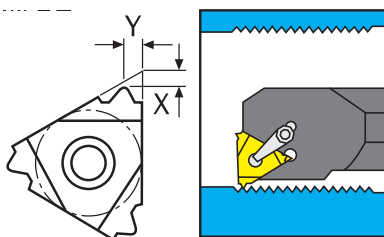

Insert Designation	TPI	X mm	Y mm	Grade	Weight per 10	Order Code YML-121	Price/1 TB
16 IR 1.00 ISO	1.00	0.6	0.7	QMA	70g	-1210Y	742.00
16 IR 1.50 ISO	1.50	0.8	1.0	QMA	65g	-1211U	742.00
16 IR 2.00 ISO	2.00	1.0	1.3	QMA	65g	-1212Q	742.00
16 IR 2.50 ISO	2.50	1.1	1.5	QMA	60g	-1213L	742.00
16 IR 3.00 ISO	3.00	1.1	1.5	QMA	60g	-1213W	742.00

Metric B-Type Toolholder & Threading Kit

QMA grade inserts (P20 - P40, K20 - K30).
Contents: 1x 16ER B 1.00 ISO insert, 1x 16ER B. 1.25 ISO insert, 1x 16ER B 1.50 ISO insert, 1x 16ER B 1.75 ISO insert, 1x 16ER B 2.00 ISO insert, 1x DER 2020 K16 toolholder, 1x T15 torx key. Supplied in plastic tube.



TOOLHOLDER + 5 INSERTS

Number of Pieces	Order Code	Price/1 TB
6	-0001A	5655.00

Partial Profiles
External Right Hand

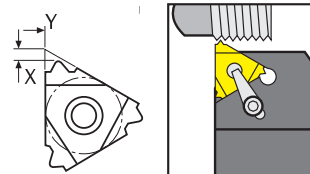

55°

Insert Designation	Pitch Range mm	TPI	X mm	Y mm	Grade	Weight per 10	Order Code YML-121	Price/1 TB
16 ER AG55	0.5-3.0	48-8	1.2	1.7	QMA	60g	-0542A	742.00

60°

Insert Designation	Pitch Range mm	TPI	X mm	Y mm	Grade	Weight per 10	Order Code YML-121	Price/1 TB
16 ER AG60	0.5-1.5	48-16	0.8	0.9	QMA	60g	-0041Q	724.00
16 ER AG60	0.5-3.0	48-8	1.2	1.7	QMA	60g	-0042A	724.00

UN

External Right Hand

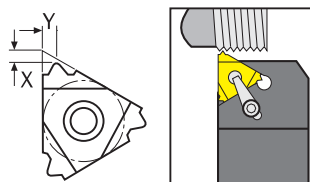

Insert Designation	TPI	X mm	Y mm	Grade	Weight each	Order Code YML-121	Price/1 TB
16 ER 24 UN	24	0.7	0.8	QMA	7g	-1546Q	742.00
16 ER 20 UN	20	0.8	0.9	QMA	7g	-1547W	742.00
16 ER 18 UN	18	0.8	1.0	QMA	7g	-1548S	742.00
16 ER 14 UN	14	1.0	1.2	QMA	7g	-1549N	742.00
16 ER 12 UN	12	1.1	1.4	QMA	7g	-1550J	742.00
16 ER 8 UN	8	1.2	1.6	QMA	7g	-1552L	742.00

UN

Internal Right Hand

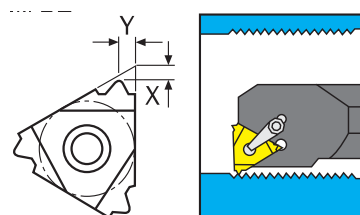

Insert Designation	TPI	X mm	Y mm	Grade	Order Code YML-121	Price/1 TB
16 IR 12 UN	12	1.1	1.4	QMA	-1750J	742.00

Whitworth

External Right Hand

A full range of sizes are available on request.

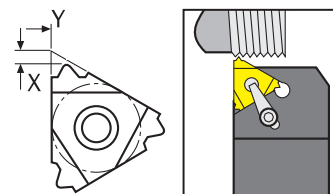

Insert Designation	TPI	X mm	Y mm	Grade	Order Code YML-121	Price/1 TB
16 ER 14 W	14	1.0	1.2	QMA	-2049N	742.00
16 ER 11 W	11	1.1	1.5	QMA	-2051E	742.00

Whitworth

Internal Right Hand

A full range of sizes are available on request.

Insert Designation	TPI	X mm	Y mm	Grade	Order Code YML-121	Price/1 TB
16 IR 14 W	14	1.0	1.2	QMA	-2215N	742.00
16 IR 11 W	11	1.1	1.5	QMA	-2217E	742.00

GROUP 139 INDEXABLE MILLING CUTTERS

INDEXA-SEIKI XP-45C 'Face Hog' Milling Cutters

Super Positive 45° approach milling cutter, angle decreases cutting forces and allows a quick feed in a limited capacity machine. Clamp style insert pocket with shim seats to protect the body in case of accident. Plasma Ion coating offers longer tool life and greater hardness that is more resistant to wear. Through coolant as standard.



CUTTING TOOLS

XP XTRA PLASMA COATED BODY

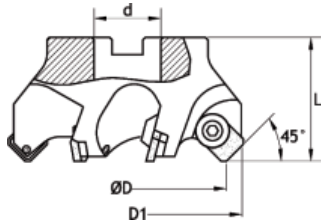

Feed Per Tooth (mm)
0.05 - 0.20
See Page 153 for Cutting Speed Information

Application Range

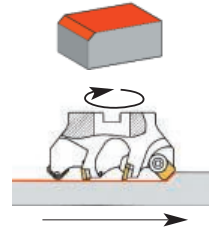

Spares to suit

Arbor Screw	Shim	Shim Screw	Clamp Screw	Hex Key
Order Code IND-107				
Price/1 TB	Price/1 TB	Price/1 TB	Price/1 TB	Price/1 TB
-5353K 149.00	-5354K 149.00	-5356K 280.00	-5358K 280.00	-1400K 1995.00
-7600K 9018.00	-7620K 12103.00	-7640K 15384.00	-7660K 17768.00	-7680K 23340.00
-4960K 357.00	-5284K 83.00	-5290K 1022.00	-5290K 1022.00	-5290K 1022.00

YAMALOY YAMALBY TOOLING • JAPAN

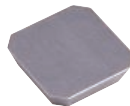

Inserts

Designation	Grade	To Suit	Order Code YML-120	Price/1 TB
SEKN 1203 AFTN	K20	Face Hog	-4517V	410.00
	QP25		-4527P	531.00
	QP40		-4527S	531.00
SEKR 1203 AFTN	K20	Face Hog	-4617V	593.00
	QP25C		-4627W	593.00

Insert Grade Description

- K20** (K20) Micrograin uncoated. For cast irons, aluminium alloys, other non-ferrous materials including titaniums and nickel alloys.
- QP25** (P25) Uncoated. For medium and finish milling of steels.
- QP25C** (P10-P35) CVD coated. Milling grade for steels and some stainless steels.
- QP40** (P40) Uncoated. For rough medium and finish milling of tough steels and stainless steels including interrupted cutting.

INDEXA-SEIKI XP-45C 'Hi Shear' Milling Cutters

Super Positive 45° approach milling cutter, angle decreases cutting forces and allows a quick feed in a limited capacity machine. Torx screws allow for good chip evacuation. Plasma Ion coating offers longer tool life and greater hardness that is more resistant to wear. Through coolant as standard.

XP XTRA PLASMA COATED BODY

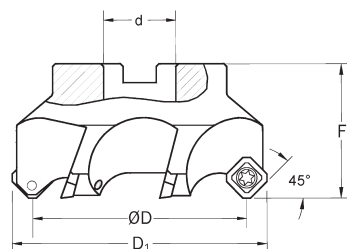
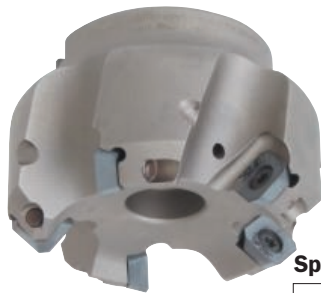

Feed Per Tooth (mm)
0.05 - 0.20
See Page 153 for Cutting Speed Information

Application Range

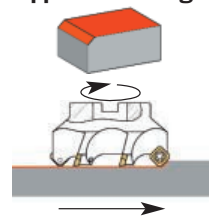

Spares to suit

Arbor Screw			Clamp Screw	Driver
Order Code IND-107				
Price/1 TB	Price/1 TB	Price/1 TB	Price/1 TB	Price/1 TB
-5353K 149.00	-5354K 149.00	-5356K 280.00	-5352K 170.00	-0220D 583.00
-7400K 9124.00	-7420K 11845.00	-7440K 13791.00		

YAMALOY YAMALBY TOOLING • JAPAN



Inserts

Designation	Grade	Order Code YML-120	Price/1 TB
SEHT 1204 AFTN	K20	-4430V	446.00
	QP25C	-4430W	629.00
SEHW 1204 AFTN-05	K20	-4445V	629.00
	QP25C	-4445W	629.00

Insert Grade Description

- K20** (K20) Micrograin uncoated. For cast irons, aluminium alloys, other non-ferrous materials including titaniums and nickel alloys.
- QP25C** (P10-P35) CVD coated. Milling grade for steels and some stainless steels.

INDEXA-SEIKI XP-90C '4 Square' 90° Shell Mills

Positive 90° cutter with an exact angle of 90°, square insert allowing depth passes and high feed per teeth. Torx style insert pocket with shim seats to protect the body in case of accident. Plasma Ion coating offers longer tool life and greater hardness that is more resistant to wear. Through coolant as standard.

XP XTRA PLASMA COATED BODY

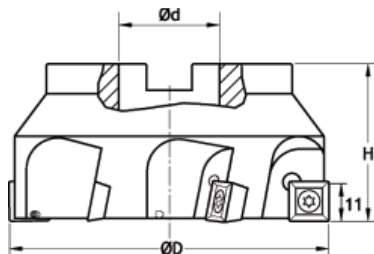

Feed Per Tooth (mm)
0.04 - 0.30
See Page 153 for Cutting Speed Information

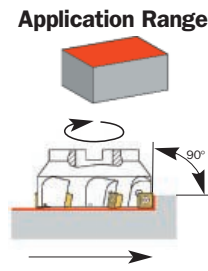

Spares to suit

Arbor Screw	Shim	Shim Pin	Clamp Screw	Driver
Order Code IND-107				Order Code KEN-603
Price/1 TB	Price/1 TB	Price/1 TB	Price/1 TB	Price/1 TB
-5354K 149.00	-2490K 274.00	-1570K 328.00	-3400K 110.00	-0150D 514.00
-5354K 149.00	-5356K 280.00			

XP-90C '4 Square' 90° Shell Mills for SDMT 12 inserts

Dia (mm)	d	H	Z	Weight each	Order Code IND-139	Price/1 TB
63	22	40	5	459g	-7500K	8594.00
80	27	50	6	999g	-7520K	12103.00
100	32	50	7	1669g	-7540K	15449.00

'Tri Square' 90° Shell Mills

Uses top clamping triangular inserts to produce a 90° shoulder at the edge of a milled face. This is of major benefit when taking a number of cuts across a face as the shoulder produced is without steps.

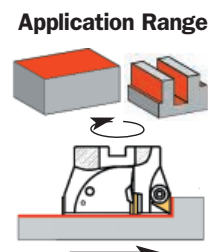
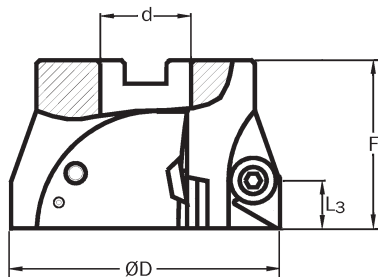

Insert Size	Feed Per Tooth (Fz) mm
TPKN 16	0.05 - 0.20
TPKN 22	0.10 - 0.30
See Page 153 for Cutting Speed Information	

Spares to suit

Arbor Screw	Shim	Shim Pin	Clamp Screw	Clamp Ring
Order Code IND-107				
Price/1 TB	Price/1 TB	Price/1 TB	Price/1 TB	Price/1 TB
-5354K 149.00	-5360K 324.00	-5362K 83.00	-0050K 88.00	-0440K 88.00
-5355K 110.00	-5357K 324.00			
Order Code IND-107				
Price/1 TB	Price/1 TB	Price/1 TB	Price/1 TB	Price/1 TB
-5357K 324.00	-5361K 357.00	-5380K 83.00	-0060K 88.00	-0500K 99.00

For TPKN 1603



Dia (mm)	d	F	L3	Z	Weight each	Order Code IND-139	Price/1 TB
63	27	50	13	4	655g	-3400K	9681.00
80	32	50	13	5	1200g	-3420K	11140.00
100	40	50	13	6	1746g	-3440K	14429.00

For TPKN 2204



Dia (mm)	d	F	L3	Z	Weight each	Order Code IND-139	Price/1 TB
100	40	50	18	5	1546g	-3460K	14429.00
125	40	63	18	6	2777g	-3480K	19097.00

Hexagon Keys

To Suit	Order Code KEN-601	Price/1 TB
Clamp Wrench (Insert 1603)	-1400K	1995.00
Clamp Wrench (Insert 2204)	-1500K	2516.00

Insert Grade Selection

K20 (K20) Micrograin uncoated.
For cast irons, aluminium alloys and other non-ferrous materials including titaniums and nickel alloys.

QP25 (P25) Uncoated. For medium and finish milling of steels.

QP40 (P40) Uncoated. For rough medium and finish milling of tough steels and stainless steels including interrupted cutting.

QX530 (P20-P40 M20-M30) Coated. Turning grade for steels, cast steels and stainless steels. A good general purpose steel grade for roughing.



Inserts

Designation	Grade	To Suit	Order Code YML-120	Price/1 TB
TPKN 1603 PPR	K20	Tri-Sq	-8428V	411.00
TPKN 1603 PPTR	QP25	Tri-Sq	-8438P	411.00
	QP40	Tri-Sq	-8438S	411.00
TPKN 2204 PDR	K20	Tri-Sq	-8458V	567.00
TPKN 2204 PDTR	QP25	Tri-Sq	-8468P	567.00
	QP40	Tri-Sq	-8468S	567.00
SDMT 12T308	QX530	4 Sq	-4280E	472.00

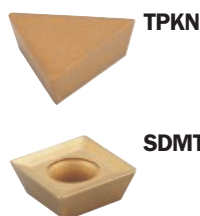

GROUP 139 INDEXABLE MILLING CUTTERS

INDEXA-SEIKI XP-90C 'APT' 90° Shell Mills



Positive 90° approach milling cutter, using size 10/16 inserts allowing depth passes and high feed per teeth. Torx screw allows for good chip evacuation. Plasma Ion coating offers longer tool life and greater hardness that is more resistant to wear. Through coolant as standard.

CUTTING TOOLS



Insert Size	Feed Per Tooth (Fz) mm
APXT 10	0.05 - 0.20
APXT 16	0.10 - 0.30
See Page 153 for Cutting speed Information	

XP-90C End Mills For AP_T 10 Inserts

D	z	H	C	L	Inserts	Order Code IND-139	Price/1 TB
10	1	20	10	80	APKT1003	-4800K	6472.00
12	1	20	12	80	or	-4820K	7772.00
16	2	25	16	90	APXT1003	-4860K	8833.00
20	3	25	20	110		-4900K	9973.00

XP-90C End Mills For AP_T 16 Inserts

D	z	H	C	L	Inserts	Order Code IND-139	Price/1 TB
20	1	37	20	115	APKT1604	-5000K	8806.00
25	2	40	25	117	or	-5020K	9018.00
32	3	40	25	126	APXT1604	-5040K	11246.00
40	4	50	32	136		-5060K	16232.00

For Inserts See Below

Spares	Arbor Screw		Clamp Screw		Flag Torx Key		Driver	
	To Suit	Price/1 TB	Order Code IND-107	Price/1 TB	Order Code IND-107	Price/1 TB	Order Code KEN-603	Price/1 TB
10-20 Dia (APKT 10)	-	-	-5240K	410.00	-	73.00	-0080D	361.00
20-25 Dia (APKT 16)	-	-	-5270K	410.00	-5150K	73.00	-0150D	514.00
32-40 Dia (APKT 16)	-	-	-5270K	410.00	-5150K	73.00	-0150D	514.00

XP-90C 'APT' 90° Shell Mills

Positive 90° approach milling cutter, using size 16 inserts allowing depth passes and high feed per teeth. Torx screw allows for good chip evacuation. Plasma Ion coating offers longer tool life and greater hardness that is more resistant to wear. Through coolant as standard.

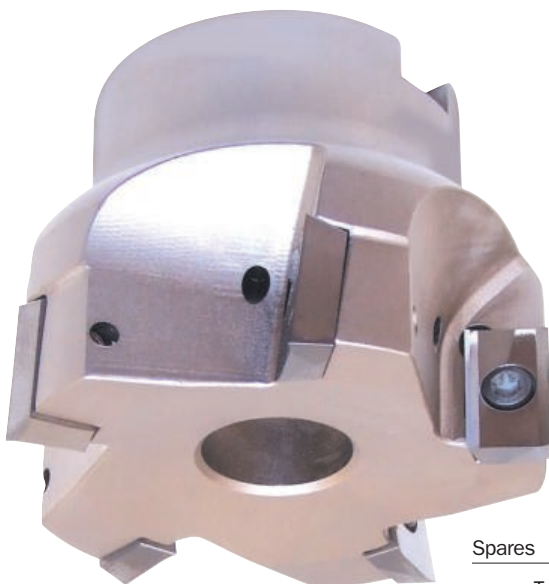

Feed Per Tooth (Fz) mm
0.10 - 0.30
See Page 153 for Cutting speed Information

XP-90C Shell Mills For APKT 16 Inserts

D	z	B	C	L	Inserts	Order Code IND-139	Price/1 TB
50	4	22	10.4	50	APKT1604	-3920K	11140.00
63	5	22	10.4	50	or	-3940K	15384.00
80	6	27	12.7	50	APXT1604	-3960K	19362.00
100	7	32	14.4	63		-3980K	22810.00

Spares	Arbor Screw		Clamp Screw		Flag Torx Key		Driver	
	To Suit	Price/1 TB	Order Code IND-107	Price/1 TB	Order Code IND-107	Price/1 TB	Order Code KEN-603	Price/1 TB
50 & 63 Dia	-	-	-5354K	149.00	-	-	-	-
80 Dia (APKT 16)	-	-	-5354K	149.00	-5270K	410.00	-0150D	514.00
100 Dia	-	-	-5355K	110.00	-	-	-	-



Insert Grade Selection

Designation	Grade	To Suit	Weight each	Order Code YML-120	Price/1 TB
APKT 1003 PDR	QK25C	APT	27g	-0028X	409.00
	QP30P	Shell Mills	35g	-0028W	346.00
	K20	Combination	85g	-0031V	409.00
APXT 1604 PDTR	QK25C	End, APT	92g	-0030X	597.00
	QP30P	Shell Mills	85g	-0030W	441.00

Insert Grade Description



- K20** (K20) Micrograin uncoated. For cast irons, aluminium alloys, other non-ferrous materials including titaniums and nickel alloys.
- QK25C** (K15-K30) Coated. For milling cast irons.
- QP30P** (P10-P35) PVD coated. Milling grade for steels and some stainless steels.



Speed Recommendations for Yamaloy Milling Inserts

Use the following table with the specific feed rates of the cutter used (found on the specific cutter page). Feed rates may vary according to work material and machine conditions but the following can be used as a general guide.

Steel Group	Materials Colour Defines Similar Machineability	Brinell Hardness HB	Rockwell Hardness HRC	Tensile Strength N/mm ²	Speed M/min					
					K20	QK25C	QP25/ QP30P	QP30P	QP40	QX530
1.1	Mild, soft and free machining non-alloy low carbon steels	up to 130	-	up to 400	-	-	140 - 200	180 - 250	80 - 50	150 - 200
1.2	Non-alloy, case hardening, structural and low to medium carbon steels	up to 200	-	up to 700	-	-	130 - 180	150 - 230	75 - 110	130 - 180
1.3	Non-alloy, plain and medium carbon steels and castings	up to 260	up to 26	up to 850	-	-	130 - 160	140 - 210	75 - 95	110 - 150
1.4	Generally low to medium alloy steels and castings	up to 260	up to 26	up to 850	-	-	120 - 160	130 - 200	70 - 90	110 - 140
1.5	Medium to high alloy steels, tool steels and castings	from 260 up to 340	from 26 up to 48	from 850 up to 1200	-	-	110 - 150	120 - 180	65 - 85	100 - 120
1.6	Heat treated alloy steels and castings	up to 230	up to 20	from 1200 up to 1500	-	-	80 - 120	110 - 150	60 - 80	70 - 90
2.1	Soft and generally easy to machine ferritic and martensitic stainless steels and castings	up to 290	up to 30	up to 800	-	-	130 - 180	150 - 200	70 - 100	80 - 120
2.2	Medium strength and easy to machine austenitic stainless steels and castings	up to 340	up to 36	up to 1000	-	-	120 - 170	130 - 180	70 - 100	60 - 100
2.3	Hard and generally difficult to machine ferritic and austenitic (duplex) stainless steels and castings	up to 180	-	up to 1200	-	-	-	40 - 50	25 - 40	50 - 90
3.1	Grey cast iron Hardness - soft to medium	from 180 up to 300	-	-	120 - 150	150 - 250	-	-	-	-
3.2	Grey cast iron Hardness - medium to hard	up to 220	-	-	90 - 130	120 - 200	-	-	-	-
3.3	Malleable and nodular iron - soft to medium	from 220 to 300 max	-	-	80 - 110	150 - 250	-	-	-	-
3.4	Malleable and nodular iron - medium to hard	-	-	-	70 - 100	120 - 200	-	-	-	-
4.1	Pure titanium (also pure nickel)	-	-	up to 700	200 - 300	-	-	-	-	-
4.2	Titanium alloys of a medium and hard nature	-	-	up to 900	50 - 80	-	-	-	-	-
4.3	Titanium alloys of a hard and very hard nature	-	-	from 900 up to 1250	20 - 50	-	-	-	-	-
5.1	Heat resistant super alloys including iron based high temperature alloys	-	-	up to 500	15 - 35	-	-	-	-	-
5.2	Heat resistant super alloys, cobalt or nickel based, of a medium to hard nature to machine	-	-	up to 900	15 - 35	-	-	-	-	-
5.3	Heat resistant super alloys, cobalt or nickel based, of a hard or very hard nature to machine	-	-	from 900 up to 1200	20 - 50	-	-	-	-	-
6.1	Copper	-	-	up to 500	250 - 400	-	-	-	-	-
6.2	Brass (alpha - long chip)	-	-	up to 800	200 - 400	-	-	-	-	-
6.3	Brass (beta - short chip) and soft bronze	-	-	up to 800	200 - 800	-	-	-	-	-
6.4	High strength bronze	-	-	up to 1200	50 - 120	-	-	-	-	-
7.1	Unalloyed: aluminium, magnesium & zinc	-	-	up to 150	500 - 900	-	-	-	-	-
7.2	Aluminium alloys less than 5% Si magnesium and zinc alloys (long chip)	-	-	from 150 up to 300	600 - 900	-	-	-	-	-
7.3	Aluminium alloys 5% to 10% Si	-	-	from 200 up to 500	300 - 600	-	-	-	-	-
7.4	Aluminium alloys above 10% Si (short chip)	-	-	from 200 up to 500	200 - 500	-	-	-	-	-
8.1	Thermoplastics	-	-	-	300 - 700	-	-	-	-	-
8.2	Thermo-setting plastics	-	-	-	300 - 500	-	-	-	-	-
8.3	Reinforced plastics & composite materials	-	-	-	100 - 300	-	-	-	-	-

GROUP 139 INDEXABLE MILLING CUTTERS

INDEXA-SEIKI QMC 06 Quad Milling Holder Set

Small diameter Indexable End Mills are taking a CCMT 06 insert. Ideal for use on manual and CNC milling machines where reach and clearance are required.

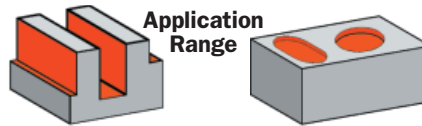

Uses **CCMT 06/CCGT 06** inserts.

Feed Per Rev (mm)
0.02 - 0.10

Dia. (mm)	d	L	L1	L2	Order Code	Price/1 TB
08	12	120	95	25	IND-139	18025.00
10	12	120	95	25		
12	12	120	95	25		
12	12	120	95	25		
16	16	120	95	25		

Insert Grade Description

QX520 (P10-P35 M10-M30 K10-K30) Coated. An excellent general purpose grade for medium roughing on steels, stainless and cast irons.

K10 (K10) Uncoated. Used in combination with a high rake geometry for machining aluminium, plastics and other soft non-ferrous materials.

QX500 (QX500) (P10-P25 Cermet). For high speed finishing and light roughing. Will maintain a high class surface finish. Mainly used on steels and can be applied to finishing some stainless steels and cast irons.



Spares

Description	To Suit	Order Code	Price/1 TB
Insert Screw	Quad Mill	-5240K	410.00
T8 Torx Key	Mill	-5080K	247.00

Insert Grade Selection

Designation	Grade	To Suit	Order Code	Price/1 TB
CCMT060204-PM	QX500	Quad Mill	-0355A	308.00
	QX520		-0355D	308.00
CCGT060202-AL	K10	Quad Mill	-0121N	409.00
CCGT060204-AL	K10	Quad Mill	-0131N	409.00

Speed & Feed Recommendations for Quad Mills

Specific feed rates may vary according to work material and machine conditions but the following can be used as a general guide.

Steel Group	Materials Colour defines similar machineability	Speed-M/Min						
		Brinell Hardness HB	Rockwell Hardness HRC	Tensile Strength N/mm ²	QX500	QX520	QX530	K10
1.1	Mild, soft and free machining non-alloy low carbon steels	up to 130	-	up to 400	200-270	180-350	150-200	
1.2	Non-alloy, case hardening, structural and low to medium carbon steels	up to 200	-	up to 700	180-250	150-320	130-180	
1.3	Non alloy, plain and medium carbon steels and castings	up to 260	up to 26	up to 850	150-220	130-280	110-150	
1.4	Generally low to medium alloy steels and castings	up to 260	up to 26	up to 850	140-210	140-210	110-140	
1.5	Medium to high alloy steels, tool steels and steel castings	from 260 up to 340	from 26 up to 48	from 850 up to 1200	140-200	130-200	100-120	
1.6	Heat treated high alloy steels and castings	from 340 up to 450	from 36 up to 48	from 1200 up to 1500	110-180	100-170	70-90	
2.1	Soft & generally easy to machine Ferritic & Martensitic stainless steels & castings	up to 230	up to 20	up to 800	90-190	110-220		
2.2	Medium strength & reasonable to machine Austenitic stainless steels & castings	up to 290	up to 30	up to 1000	70-160	70-140	60-100	
2.3	Hard & generally difficult to machine Ferritic & Austenitic (duplex) stainless steels & castings	up to 340	up to 36	up to 1200			50-90	
3.1	Grey cast iron Hardness - soft to medium	up to 180	-		175-280	190-400		
3.2	Grey cast iron Hardness - medium to hard	from 180 up to 300	-		160-250	150-300		
3.3	Malleable and Nodular irons - soft to medium	up to 220	-		200-250			
3.4	Malleable and Nodular irons - medium to hard	from 220 up to 300	-		200-250			
6.1	Copper	-	-	up to 500	200-250			100-500
6.2	Brass (Alpha - long chip)	-	-	up to 800	300-500			400-700
6.3	Brass (Beta - short chip) & soft Bronze	-	-	up to 800	300-500			400-700
7.1	Unalloyed: Aluminium, Magnesium & Zinc	-	-	up to 150	300-500			400-600
7.2	Aluminium alloys less than 5% Si Magnesium & Zinc alloys (long chip)	-	-	from 150 up to 300				300-500
7.3	Aluminium alloys 5% to 10% Si	-	-	from 200 up to 500				400-700
7.4	Aluminium alloys above 10% Si (short chip)	-	-	from 200 up to 500				400-700
8.1	Thermoplastics							200-500
8.2	Thermo-setting plastics							
8.3	Reinforced plastics & composite materials							

INDEXA-SEIKI Multi-Pro Spot Drills & Chamfer Mills

A spotting drill with all the advantages of indexable inserts - reduced tool maintenance time, increased performance, lower inventory cost and no regrinding requirements. The insert clamping method ensures accurate and secure location with quick change-over times. Multi-pro has a unique geometry which allows cutting over the centre line, using carbide, without chipping of the cutting edge. This versatile tool may be used to 'spot' holes prior to drilling, as a means to guide the drill and keep the hole straight, to keep size and accurately position, relative to the datum.

NB. The 118° inclusive tool is recommended for 'spotting' prior to drilling with 118° point drills. Countersinks may be produced prior to drilling to provide a corner break on a drilled hole, a chamfer conforming to drawing specifications, a lead in for a subsequent tapping operation, or a full countersink to accommodate a screw head. Corner chamfers on edges, contours and bores can be machined as light de-burring operations or full depth chamfers. Multi-pro may be used to produce vee grooves for fluid channels, locations for round components and grip pattern or serrations on jaws and clamp pads.

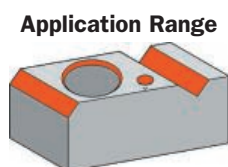

Application Range



SCM1045C SC1645C SC1630C



Hole Chamfer

Vee Groove Milling

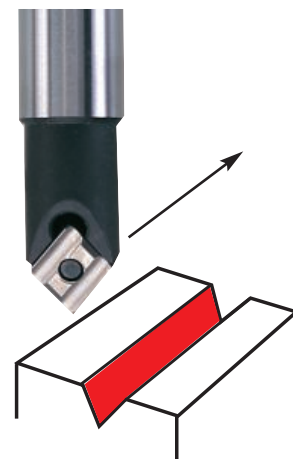

Hole Chamfer

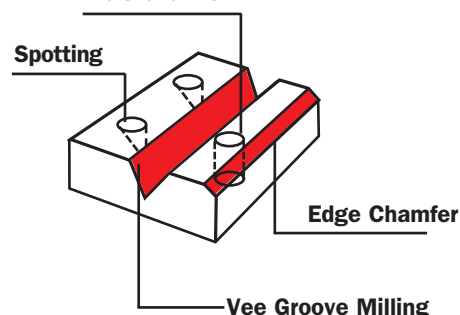

Spotting

Edge Chamfer

Vee Groove Milling

'Multi Pro Mini' - Uses C22 GUX Inserts

Designation	Cutting Diameter	Overall Length	Included Angle	Shank Diameter	Weight each	Order Code IND-139	Price/1 TB
SCM 1045C	8mm	105mm	90°	10mm	78g	-8050K	12875.00

'Multi Pro Standard' - Uses C32 GUX Inserts

Designation	Cutting Diameter	Overall Length	Included Angle	Shank Diameter	Weight each	Order Code IND-139	Price/1 TB
SC 1645C	13mm	110mm	90°	16mm	174g	-8545K	13133.00
SC 1630C	16mm	110mm	118°	16mm	184g	-8530K	13133.00

Insert Grade Description

QM10 (ISO P10/M10/K10) Tin Coated Multi-purpose grade for general use, can cut the majority of ferrous and non-ferrous materials used in industry.



QS20 (ISO P20) Uncoated Grade for steel and stainless steel application.

QC10 (ISO K10) Uncoated Grade for cast irons, aluminiums, and non-ferrous materials.

Inserts

Designation	Grade	To Suit	Order Code YML-122	Price/1 TB
C22 GUX	QM10	Multi-Pro Mini	-0080N	2389.00
C32 GUX	QS20	Multi-Pro	-0102P	1949.00
C32 GUX	QC10	Standard	-0100N	1698.00

Spares

Insert Screw	Order Code IND-107	Price/1 TB
To suit SCM1045C	-3249K	239.00
To suit SC1645C & SC1630C	-4800K	384.00

Speed & Feed Recommendations for Multi-Pro

Group	Materials	Rockwell Hardness HRC	Recommended Grade	Cutting Speed M/min	Type of Operation	Feed/Rev		
						Pro Mini 105mm	Pro Standard 110mm	Pro Mini 165mm
1.1 to 1.3	Alloy Steels and castings	from 36 up to 45	QS20 QM10	80~100	Spot Drilling Chamfer Milling	0.020 0.050	0.026 0.070	0.013 0.040
1.4 to 1.6	Tool and die steels	from 45 up to 55	QS20 QM10	55~65	Spot Drilling Chamfer Milling	0.012 0.030	0.016 0.050	0.008 0.020
2.1 to 2.3	Stainless steels	up to 36	QS20 QM10	70~90	Spot Drilling Chamfer Milling	0.020 0.040	0.026 0.060	0.013 0.030
3.1 to 3.4	Cast irons	-	QC10 QM10	100~120	Spot Drilling Chamfer Milling	0.034 0.050	0.045 0.070	0.022 0.040
6.1 to 6.6	Copper alloys brass and bronze	-	QC10 QM10	120~150	Spot Drilling Chamfer Milling	0.034 0.050	0.045 0.070	0.022 0.040
7.1 to 7.4	Aluminium alloys	-	QC10 QM10	120~150	Spot Drilling Chamfer Milling	0.034 0.050	0.045 0.070	0.022 0.040

GROUP 140 SPINDLE NOSE TOOLING

INDEXA-SEIKI Standard Pull Studs

BT-MAS 403

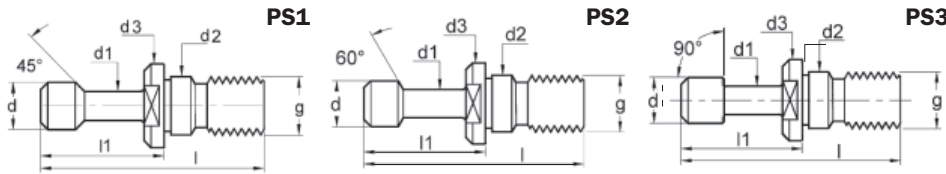

BT-MAS 403

Product Number Taper - Type	Dimensions (mm)								Order Code IND-140	Price/1 TB
	l	l1	d	d1	d2	d3	g			
BT30 - PS1	43.0	23.0	11.0	7.0	12.5	16.5	M12		-9230K 1009.00	
BT40 - PS1	60.0	35.0	15.0	10.0	17.0	23.0	M16		-9240K 1009.00	
BT40 - PS2	60.0	35.0	15.0	10.0	17.0	23.0	M16		-9242K 1009.00	
BT40 - PS3	60.0	35.0	15.0	10.0	17.0	23.0	M16		-9243K 1316.00	
BT45 - PS1	70.0	40.0	19.0	14.0	21.0	31.0	M20		-9245K 1115.00	
BT45 - PS2	70.0	40.0	19.0	14.0	21.0	31.0	M20		-9247K 1115.00	
BT45 - PS3	70.0	40.0	19.0	14.0	21.0	31.0	M20		-9248K 1236.00	
BT50 - PS1	85.0	45.0	23.0	17.0	25.0	38.0	M24		-9250K 1327.00	
BT50 - PS2	85.0	45.0	23.0	17.0	25.0	38.0	M24		-9252K 1327.00	
BT50 - PS3	85.0	45.0	23.0	17.0	25.0	38.0	M24		-9253K 1327.00	

DIN 69871/A

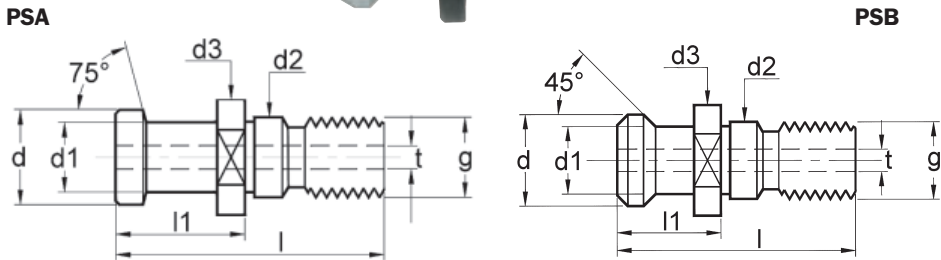

ISO 7388/2 (DIN 69871/A) (SQ = Square Shoulder)

Product Number Taper-Shoulder-Type	Dimensions (mm)								Order Code IND-140	Price/1 TB
	l	l1	d	d1	d2	d3	t	g		
DN40-SQ-PSB	44.5	16.4	18.9	12.9	17.0	22.5	7.5	M16	-9142K 1545.00	
DN50-SQ-PSB	65.5	25.5	29.0	19.6	25.0	36.0	11.5	M24	-9152K 1648.00	

DIN 69872

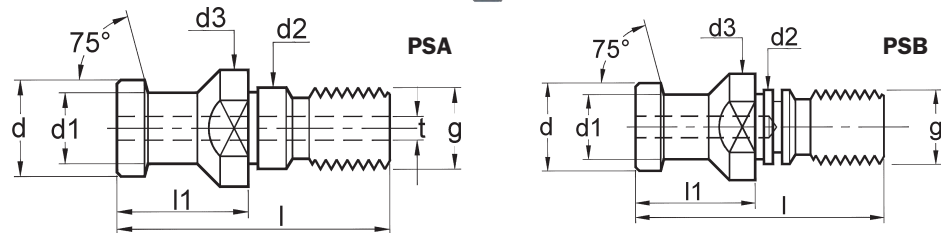

DIN 69872 (CH = Chamfered Shoulder)

Product Number Taper-Shoulder-Type	Dimensions (mm)								Order Code IND-140	Price/1 TB
	l	l1	d	d1	d2	d3	t	g		
DN40-CH-PSA	54.0	26.0	19.0	14.0	17.0	23.0	7.5	M16	-9040K 797.00	
DN45-CH-PSB	65.0	30.0	23.0	17.0	21.0	30.0	-	M20	-9047K 1545.00	
DN50-CH-PSA	74.0	34.0	28.0	21.0	25.0	36.0	11.5	M24	-9050K 1545.00	

INDEXA Tool Locking Fixtures



Universal

Made from cast aluminium with machined carbon steel fittings, these fixtures are an invaluable asset in your machine shop. Universal in use, suitable for BT, DIN and CAT tool holders. Designed to give maximum protection for your tool holder whilst enabling strong gripping power to be exerted in both horizontal and vertical positions. It is tough but remains light in weight and its compact design makes it ideal for mounting on a work table or tool cart.

Overall dimensions (L x W x H)

Taper size 40: 200 x 155 x 100mm.

Taper size 50: 270 x 210 x 145mm.



Vertical

Taper Size BT-DIN-CAT	Weight each	Order Code IND-140	Price/1 TB
30	1.9kg	-6630K	10815.00
40	1.9kg	-6640K	10815.00
50	4.2kg	-6650K	13905.00

Tool Blocks

For use on manual and CNC lathes, this universal style tool block will accurately clamp all parting blades of the corresponding width, 26mm or 32mm. The rigid clamping method allows blades to be set securely for varying depths of cut.

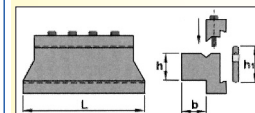
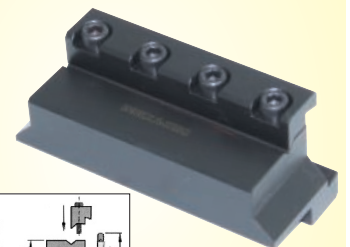

Product Number	h1	L	h & b	Order Code IND-152	Price/1 TB
DPTS-2620	26	87	20	-1160K	10057.00
DPTS-2625	26	87	25	-1162K	10057.00
DPTS-3220	32	100	20	-1170K	10057.00
DPTS-3225	32	110	25	-1172K	10057.00
DPTS-3232	32	120	32	-1174K	10057.00

KENNEDY Industrial Drill Chuck Arbors
QUALITY INDUSTRIAL TOOLING

Precision machined, fully hardened and ground to give maximum surface contact.

Morse Taper Drive to Jacobs Taper



Description	Overall Length	Weight each	Order Code KEN-442	Price/1 TB
No.1 MT x 1JT	90mm	70g	-9110K	240.00
No.1 MT x 2JT	95mm	80g	-9120K	240.00
No.1 MT x 6JT	96mm	100g	-9160K	255.00
No.1 MT x 33JT	95mm	90g	-9190K	442.00
No.2 MT x 1JT	100mm	150g	-9210K	227.00
No.2 MT x 2JT	105mm	160g	-9220K	285.00
No.2 MT x 3JT	115mm	220g	-9230K	263.00
No.2 MT x 6JT	110mm	180g	-9260K	316.00
No.2 MT x 33JT	110mm	180g	-9290K	242.00
No.3 MT x 1JT	120mm	310g	-9310K	595.00
No.3 MT x 2JT	125mm	330g	-9320K	329.00
No.3 MT x 3JT	135mm	380g	-9330K	336.00
No.3 MT x 4JT	145mm	520g	-9340K	357.00
No.3 MT x 5JT	150mm	680g	-9350K	1906.00
No.3 MT x 6JT	130mm	340g	-9360K	357.00
No.3 MT x 33JT	125mm	340g	-9390K	457.00
No.4 MT x 2JT	135mm	700g	-9420K	818.00
No.4 MT x 3JT	160mm	730g	-9430K	818.00
No.4 MT x 4JT	170mm	860g	-9440K	818.00
No.4 MT x 5JT	175mm	1000g	-9450K	1906.00
No.4 MT x 6JT	155mm	690g	-9460K	818.00
No.4 MT x 33JT	155mm	680g	-9490K	818.00
No.5 MT x 3JT	190mm	1700g	-9530K	2023.00
No.5 MT x 5JT	210mm	1900g	-9550K	2023.00

Bridgeport Drive to Jacobs Taper

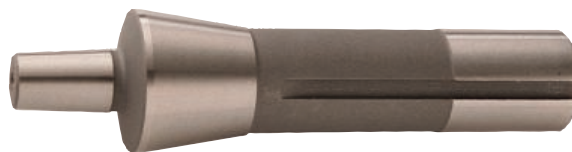

Description	Overall Length	Weight each	Order Code KEN-442	Price/1 TB
R8 x 1JT	130mm	420g	-9610K	2201.00
R8 x 2JT	135mm	440g	-9620K	2201.00
R8 x 3JT	145mm	510g	-9630K	2201.00
R8 x 6JT	135mm	450g	-9660K	1834.00
R8 x 33JT	135mm	460g	-9690K	1570.00

Morse Taper Drive to Threaded



Description	Overall Length	Weight each	Order Code KEN-442	Price/1 TB
No.1 MT 1/2 x 20	92mm	100g	-1120K	1507.00
No.1 MT 3/8 x 24	95mm	80g	-1380K	1507.00
No.2 MT 1/2 x 20	105mm	170g	-2120K	1789.00
No.2 MT 3/8 x 24	105mm	170g	-2380K	1789.00
No.2 MT 5/8 x 16	105mm	180g	-2580K	1789.00
No.3 MT 1/2 x 20	125mm	360g	-3120K	1977.00
No.3 MT 5/8 x 16	125mm	370g	-3580K	1977.00

KD Type - Morse Taper Shank to Din Taper Arbors
 Fully hardened and ground Morse Taper to DIN 228. Chuck taper to DIN 238.



Morse Taper	Chuck Taper	Overall length	Order Code KEN-442	Price/1 TB
No.2 MT	B12	106.5mm	-5220K	205.00
No.2 MT	B16	111.5mm	-5260K	205.00
No.3 MT	B12	125.0mm	-5320K	286.00
No.3 MT	B16	134.0mm	-5360K	286.00
No.4 MT	B16	159.0mm	-5420K	476.00
No.4 MT	B22	176.0mm	-5460K	476.00

INDEXA-SEIKI Shank Adaptors



R8 Shank Sidelock Adaptors

For Bridgeport type turret milling machine spindles to accept weldon shank (DIN 1835B) cutters.

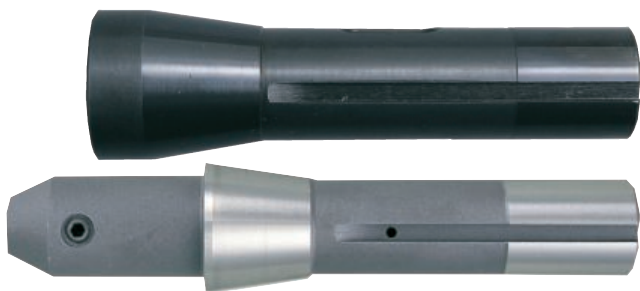

Shank	Bore Size	Weight each	Order Code IND-144	Price/1 TB
R8	SL20	1209g	-3568K	4996.00
R8	SL25	1952g	-3570K	4996.00

R8 Shank Morse Adaptors



Shank	Bore Size	Weight each	Order Code IND-144	Price/1 TB
R8	MT1	400g	-5592K	5665.00
R8	MT2	332g	-5594K	6695.00
R8	MT3	881g	-5596K	7210.00

R8 Shank Face Mill Adaptors

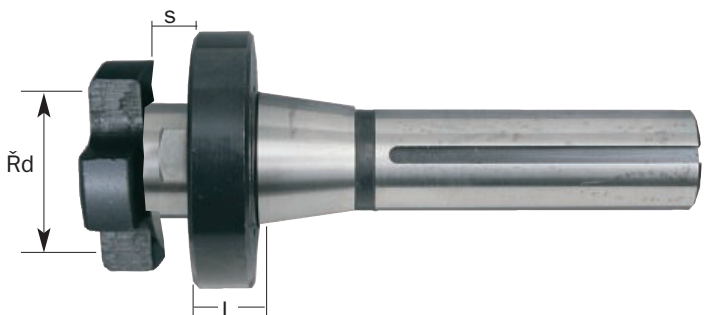

Shank	Spigot Size	d	s	Gauge Length (L)	Weight each	Order Code IND-144	Price/1 TB
R8	FM16	16	6	15	512g	-4970K	6695.00
R8	FM22	22	10	15	696g	-4972K	6695.00
R8	FM27	27	12	15	741g	-4974K	7725.00
R8	FM32	32	16	17	938g	-4976K	8755.00

R8 Collets for Bridgeport

Used directly in the machine spindle for general purpose milling and drilling operations, collets have dedicated bores for specific cutter shank sizes.

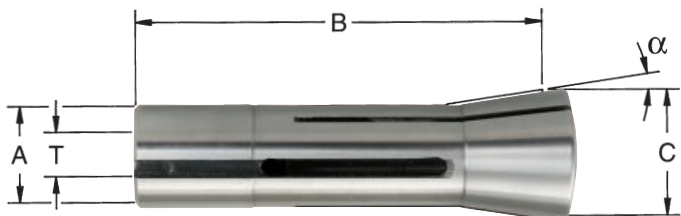

Dimensions: A = 24.1mm, B = 102.3mm, C = 31.5mm T = 7/16" UNF. Angle: alpha = 8°25'.

Bore Size	Weight each	Order Code IND-144	Price/1 TB
3.0mm	291g	-3622K	1803.00
6.0mm	298g	-3580K	1803.00
8.0mm	304g	-3630K	1803.00
10.0mm	297g	-3582K	1803.00
11.0mm	299g	-3634K	1803.00
12.0mm	295g	-3584K	1803.00
14.0mm	283g	-3638K	1803.00
16.0mm	275g	-3586K	1803.00
20.0mm	209g	-3588K	1803.00

GROUP 144 SPINDLE NOSE TOOLING

INDEXA-SEIKI ER - Collet Chucks

Europe's most popular collet system. Collapsing collet design can be used for a range of diameters and maintains concentricity for drilling and milling. Long reach options available to give access into deep recesses.



CUTTING TOOLS

BT = BT-MAS 403.....(See main picture)

DN = DIN69871/A.....

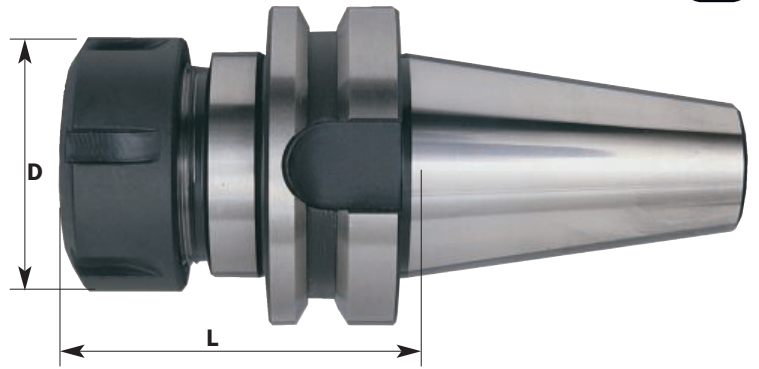

DN = DIN 69871/A

Shank	Collet Diameter	L	D	Weight each	Order Code IND-144	Price/1 TB
DN40	ER16	100	28	929g	-2710K	5665.00
	ER16	150	28	1608g	-2712K	5768.00
	ER25	60	42	1119g	-2714K	6695.00
	ER32	70	50	1253g	-2716K	6953.00
	ER32	130	50	1744g	-2718K	8755.00
	ER40	70	63	1293g	-2720K	9270.00

Straight Shank - Mini Extension

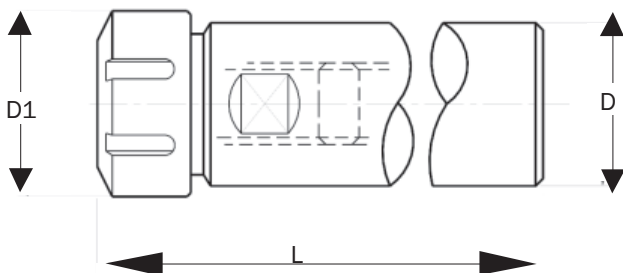

Product Number	Collet Diameter	D ₁	L	D	Weight each	Order Code IND-144	Price/1 TB
SSE20	ER16	22	160	20	305g	-2880K	8755.00

BT = BT-MAS 403

Shank	Collet Diameter	L	D	Weight each	Order Code IND-144	Price/1 TB
BT30	ER16	60	32	539g	-2792K	6695.00
	ER32	60	50	1100g	-2796K	5665.00
	ER16	60	32	1002g	-2798K	4883.00
	ER16	100	28	1240g	-2800K	7285.00
BT40	ER16	150	28	1240g	-2802K	8233.00
	ER25	60	42	1155g	-2804K	6090.00
	ER32	70	50	1299g	-2806K	6090.00
	ER32	130	50	2177g	-2808K	7659.00
	ER40	70	63	1334g	-2810K	6090.00
BT50	ER16	100	28	3827g	-2816K	12978.00
	ER32	70	50	3807g	-2832K	8704.00
	ER32	130	50	4664g	-2834K	11272.00
	ER40	80	63	4041g	-2836K	10815.00

Straight Shank

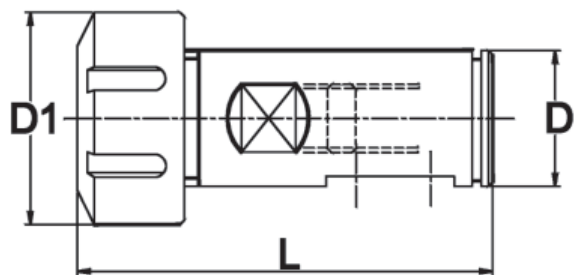

Product Number	Collet Diameter	D ₁	L	D	Weight each	Order Code IND-144	Price/1 TB
SS32	ER32	50	098	32	655g	-2850K	7171.00
SS40	ER32	50	118	40	913g	-2860K	8077.00



INDEXA-SEIKI ER Industrial Hook Wrench

For ER8/ER40 collet nuts.
Adjustable size, drop forged steel.
Single hand adjustment. One spanner will cover 35 - 105 collet nuts.

To suit collets: ER 8, 16, 25, 32 and 40.
Metric sizes: 35, 50, 60, 70, 80, 90 and 105mm.



Description	Weight each	Order Code IND-140	Price/1 TB
Adjustable	500g	-8100K	2215.00

Spanners & Locknuts

Suitable for all collet chucks including straight shank.



Spanners

Chuck Type	Order Code KEN-580	Price/1 TB
ER16 Mini	-5160K	397.00
ER16	-5300K	423.00
ER25	-5400K	423.00
ER32	-5450K	423.00



ER - Single Angle Collets

Manufactured from hardened and tempered high alloy steel.
Conform to **DIN 6499**.

Range mm	Weight each	Order Code IDX-144	Price/1 TB
ER11			
1.00	4g	-2872K	955.00
1.50	5g	-2874K	955.00
2.00	6g	-2876K	955.00
2.50	7g	-2878K	955.00
3.00	8g	-2880K	955.00
3.50	10g	-2882K	955.00
4.00	12g	-2884K	955.00
4.50	15g	-2886K	955.00
5.00	19g	-2888K	955.00
5.50	25g	-2890K	955.00
6.00	28g	-2892K	955.00
6.50	30g	-2894K	955.00
7.00	35g	-2896K	955.00
ER16			
1.0-0.5	26g	-3200K	955.00
2.0-1.0	25g	-3210K	955.00
3.0-2.0	27g	-3220K	955.00
4.0-3.0	28g	-3230K	955.00
5.0-4.0	22g	-3240K	955.00
6.0-5.0	19g	-3250K	955.00
7.0-6.0	19g	-3260K	955.00
8.0-7.0	17g	-3270K	955.00
9.0-8.0	21g	-3280K	955.00
10.0-9.0	15g	-3290K	955.00
ER20			
3.0-2.0	41g	-3312K	955.00
4.0-3.0	40g	-3314K	955.00
5.0-4.0	40g	-3316K	955.00
6.0-5.0	42g	-3318K	955.00
7.0-6.0	44g	-3320K	955.00
8.0-7.0	25g	-3322K	955.00
9.0-8.0	36g	-3324K	955.00
10.0-9.0	36g	-3326K	955.00
11.0-10.0	32g	-3328K	955.00
12.0-11.0	31g	-3330K	955.00
13.0-12.0	25g	-3332K	955.00
ER25			
2.0-1.0	74g	-3400K	1057.00
3.0-2.0	76g	-3410K	1057.00
4.0-3.0	75g	-3420K	1057.00
5.0-4.0	76g	-3430K	1057.00
6.0-5.0	75g	-3440K	1057.00
7.0-6.0	72g	-3450K	1057.00
8.0-7.0	73g	-3460K	1057.00
9.0-8.0	71g	-3470K	1057.00
10.0-9.0	68g	-3480K	1057.00
11.0-10.0	67g	-3490K	1057.00

Range mm	Weight each	Order Code IDX-144	Price/1 TB
ER25 Continued			
12.0-11.0	65g	-3500K	1057.00
13.0-12.0	59g	-3510K	1057.00
14.0-13.0	55g	-3520K	1057.00
15.0-14.0	52g	-3530K	1057.00
16.0-15.0	46g	-3540K	1057.00
ER32			
3.0-2.0	140g	-3700K	1210.00
4.0-3.0	141g	-3710K	1210.00
5.0-4.0	146g	-3720K	1210.00
6.0-5.0	147g	-3730K	1210.00
7.0-6.0	145g	-3740K	1210.00
8.0-7.0	148g	-3750K	1210.00
9.0-8.0	145g	-3760K	1210.00
10.0-9.0	141g	-3770K	1210.00
11.0-10.0	139g	-3780K	1210.00
12.0-11.0	134g	-3790K	1210.00
13.0-12.0	133g	-3800K	1210.00
14.0-13.0	128g	-3810K	1210.00
15.0-14.0	123g	-3820K	1210.00
16.0-15.0	119g	-3830K	1210.00
17.0-16.0	112g	-3840K	1210.00
18.0-17.0	103g	-3850K	1210.00
19.0-18.0	101g	-3860K	1210.00
20.0-19.0	44g	-3870K	1210.00
ER40			
4.0-3.0	252g	-4000K	1242.00
5.0-4.0	268g	-4010K	1242.00
6.0-5.0	270g	-4020K	1242.00
7.0-6.0	263g	-4030K	1242.00
8.0-7.0	274g	-4040K	1242.00
9.0-8.0	261g	-4050K	1242.00
10.0-9.0	278g	-4060K	1242.00
11.0-10.0	276g	-4070K	1242.00
12.0-11.0	274g	-4080K	1242.00
13.0-12.0	268g	-4090K	1242.00
14.0-13.0	263g	-4100K	1242.00
15.0-14.0	258g	-4110K	1242.00
16.0-15.0	250g	-4120K	1242.00
17.0-16.0	248g	-4130K	1242.00
18.0-17.0	242g	-4140K	1242.00
19.0-18.0	238g	-4150K	1242.00
20.0-19.0	224g	-4160K	1242.00
21.0-20.0	216g	-4170K	1242.00
22.0-21.0	207g	-4180K	1242.00
23.0-22.0	194g	-4190K	1242.00
24.0-23.0	186g	-4200K	1242.00
25.0-24.0	176g	-4210K	1242.00
26.0-25.0	165g	-4220K	1242.00

ER - Collet Sets

Manufactured from hardened and tempered high alloy steel.
All supplied in hard wearing bench cases.
Conform to **DIN 6499**.



Collet Dimensions (mm)

Type	Capacity	D	L
ER16	0.5-10	17.0	27.0
ER20	3.0-13	21.0	31.5
ER25	1.0-16	26.0	35.0
ER32	2.0-20	33.0	40.0
ER40	3.0-26	41.0	46.0

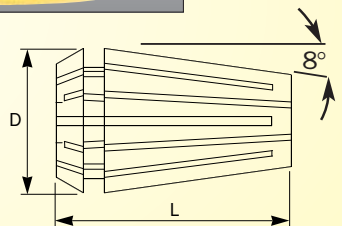

Collet Type	Number of Collets	Range Dia. (mm)	Weight each	Order Code IDX-144	Price/1 TB
ER16	9	1.0 - 10.0	535g	-9010K	7002.00
ER20	11	2.0 - 13.0	637g	-9015K	8912.00
ER25	15	1.0 - 16.0	1207g	-9020K	10822.00
ER32	18	2.0 - 20.0	4.8kg	-9030K	13368.00
ER40	23	3.0 - 26.0	5.5kg	-9040K	21006.00

PRODUCTS ARE ONLY AVAILABLE VIA YOUR DISTRIBUTOR

GROUP 144 SPINDLE NOSE TOOLING

INDEXA-SEIKI

CUTTING TOOLS

BT

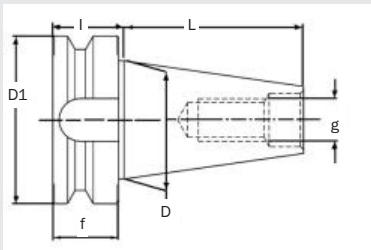

**Japanese Standard
BT-MAS 403**



Taper	D	D1	f	g	I	L
30	31.75	46	20	M12	22	48.4
35	38.10	53	22	M12	24	56.5
40	44.45	63	25	M16	27	65.4
45	57.15	85	30	M20	33	82.8
50	69.85	100	35	M24	38	101.8

ISO Including Quick Change.

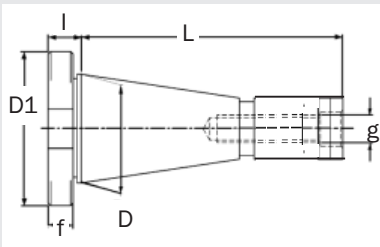

**ISO Standard
ISO R 297-2583 - DIN 2080**



ISO

Taper	D	D1	f	g	I	L	L1
30	31.75	50	8	M12	9.61	68.39	-
40	44.45	63	10	M16	11.6	93.40	7
45	57.15	80	12	M20	15.2	106.8	-
50	69.85	97.5	12	M24	15.2	126.8	13

Quick Change

Taper	D	D1	L	f	I	g
30	31.75	46.0	69	8.76	10.7	M12
40	44.45	63.5	93	7.98	9.9	M16

FM - Face Mill Adaptors

From an extensive programme of quality spindle nose tooling, used with an extensive range of face and shell mills.

BT = BT-MAS 403 (See main picture)

DN = DIN69871/A.....



IS = ISO/DIN 2080/

QC = ISO/DIN 2080 Quick Change.....

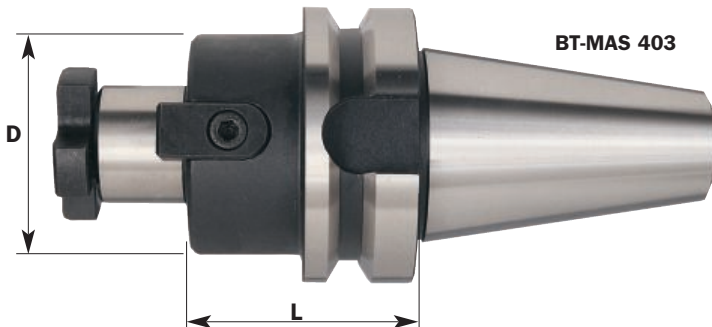

Shank	Spigot Diameter	L	D	Weight each	Order Code IND-144	Price/1 TB
DN40	FM22	60	50	1554g	-4610K	13156.00
	FM22	120	40	2167g	-4612K	13898.00
	FM27	60	50	1602g	-4614K	16869.00
	FM27	120	48	2705g	-4616K	18991.00
QC40	FM32	60	78	2326g	-4618K	13262.00
	FM22	37	40	1125g	-4810K	12731.00
	FM22	90	40	1845g	-4812K	13898.00
	FM27	37	48	1275g	-4814K	13898.00
	FM32	37	58	1558g	-4818K	14853.00
	FM40	37	70	2025g	-4822K	14853.00

Shank	Spigot Diameter	L	D	Weight each	Order Code IND-144	Price/1 TB
BT40	FM16	52	36	1.2kg	-4907K	14853.00
	FM22	52	50	1.5kg	-4910K	14853.00
	FM22	120	40	2.2kg	-4912K	15914.00
	FM27	52	50	1.5kg	-4914K	14853.00
	FM27	120	48	2.7kg	-4916K	15914.00
	FM32	52	78	2.2kg	-4918K	15119.00
FM40	60	89	2.9kg	-4922K	15914.00	

MT - Morse Taper Adaptors

With internal morse taper socket. For use on drilling machines etc. For drills, core drills, reamers etc. Manufactured to stringent quality standards.

BT = BT-MAS 403.....(See main picture)

**QC = ISO/DIN 2080
Quick Change.....**

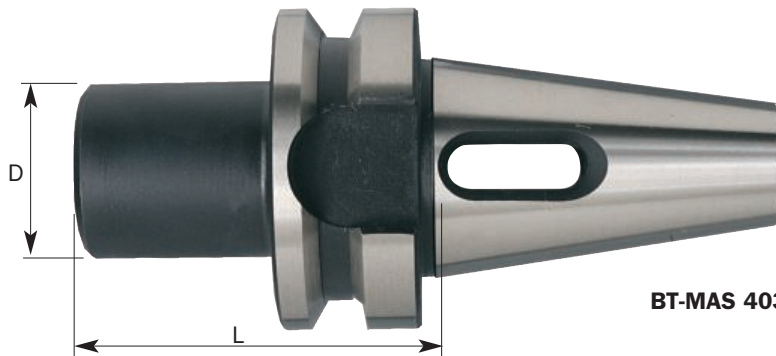
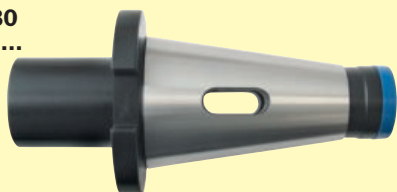

Shank	Morse Taper	L	D	Weight each	Order Code IND-144	Price/1 TB
QC40	2	50	32	882g	-5826K	5665.00
	3	65	40	1008g	-5830K	5665.00
	4	95	48	1304g	-5834K	6695.00

Shank	Morse Taper	L	D	Weight each	Order Code IND-144	Price/1 TB
BT40	1	50	25	1033g	-5922K	7210.00
	2	50	32	1050g	-5926K	7210.00
	3	70	40	1186g	-5930K	7210.00
	4	95	48	1394g	-5934K	7725.00
BT50	3	65	40	3750g	-5974K	9785.00

INDEXA-SEIKI Tapping Head Sets

Adjustable torque control protects against tap breakage/overload. Auto-reverse withdraws the tap without reversing the machine spindle. Each set is supplied complete with two rubber flex collets, two Morse arbors, kick bar and wrenches. Suitable for use with ISO, DIN and ANSI taps. These tapping heads are suitable for light and medium duty applications not for production machining. Range capacity is nominal sizes only and is dependent on tap shank dimensions (ISO or DIN).



Model JSN-7
IND- 144-8010K



Model JSN-12
IND- 144-8020K



Model JSN-20
IND- 144-8030K



Model	Range	Morse Taper	Recommended Max. Speed	Reverse Ratio	Body Diameter	Overall Length	Clockwise Compression	Self Feed*	Clockwise Expansion	Weight each	Order Code IND-144	Price/1 TB
JSN-7	M2-7	1 & 3	1500 RPM	01:01.6	52mm	130mm	5.0mm	3.5mm	10.0mm	2.10kg	-8010K	19569.00
JSN12	M4-12	3 & 4	1000 RPM	01:01.8	75mm	156mm	5.0mm	4.5mm	14.0mm	4.20kg	-8020K	25750.00
JSN-20	M8-20	3 & 4	600 RPM	01:01.7	90mm	205mm	6.0mm	6.0mm	14.0mm	7.00kg	-8030K	27810.00

Flexible Rubber Collet Sets
To suit Indexa-Seiki tapping heads. Supplied as sets of two collets.



Tapping Head	Contact Length	Cone Angle	Outside Diameter	Weight each	Order Code IND-140	Price/1 TB
JSN - 7	12mm	36°	15µm	10γ	-9600K	3089.00
JSN - 12	12mm	36°	22µm	20γ	-9610K	3089.00
JSN - 20	12mm	36°	26µm	40γ	-9620K	3089.00

Arbors

Suitable for	Morse taper to Jacobs taper	Overall Length	Weight Each	Order Code KEN-442	Price/1 TB
JSN-7& JSN-12	1MT x 6JT	96mm	100g	-9160K	255.00
	2MT x 6JT	110mm	180g	-9260K	316.00
	3MT x 6JT	130mm	340g	-9360K	357.00
JSN-20	4MT x 6JT	155mm	690g	-9460K	818.00
				Order Code IND-140	Price/1 TB
	3MT x M20 x 2.5			-9430K	1442.00
	4MT x M20 x 2.5			-9440K	1442.00

GROUP 144 TAPPING CHUCKS & COLLETS

INDEXA-SEIKI Tapping Chucks - Tension & Compression Type

With axial compensation. Suitable for use on boring machines and machining centres.



ISO/DIN 69871-A Taper Shank

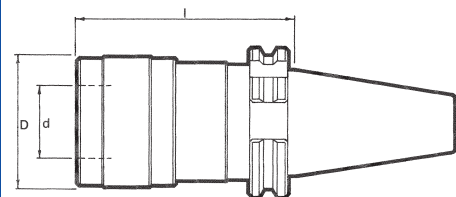

Collet Size (d)	Shank Size	Dimensions D	Dimensions I	Tapping Range	Compression Range	Extension Range	Order Code IND-144	Price/1 TB
SC19	DN40	38.0	60	M3 - M12	9.0	9.0	-8630K	15965.00
	DN50	38.0	62	M3 - M12	9.0	9.0	-8640K	22660.00

MAS 403 BT Taper Shank

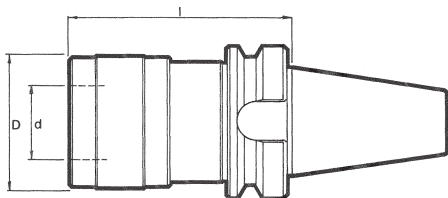

Collet Size (d)	Shank Size	Dimensions D	Dimensions I	Tapping Range	Compression Range	Extension Range	Order Code IND-144	Price/1 TB
SC19	BT40	38.0	68	M3 - M12	9.0	9.0	-8610K	15862.00
	BT50	38.0	80	M3 - M12	15.0	15.0	-8620K	25905.00
SC31	BT40	55.0	93	M6-M20	15.0	15.0	-8612K	20085.00
	BT50	55.0	102	M6-M20	15.0	15.0	-8622K	30488.00

Tapping Collets

Slipping clutch type. To suit tension and compression type tapping chucks shown above.

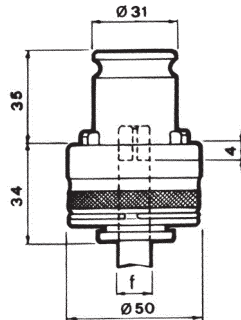
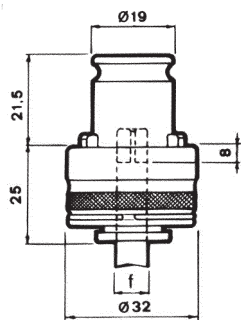

Size (d) SC19/1	For DIN Taps	Dimensions Shank	Dimensions A/F	Order Code IND-144	Price/1 TB
352	371 374 376				
335	M3 M3	3.5	2.7	-9230K	4893.00
445	M4 M4	4.5	3.4	-9232K	4893.00
645	M6 M6	4.5	3.4	-9234K	4893.00
56	M5 M5	6.0	4.9	-9220K	4893.00
6649	M6 M6	6.0	4.9	-9238K	4893.00
86	M8 M8	6.0	4.9	-9222K	4893.00
88	M8 M8	8.0	6.2	-9224K	4893.00
997	M9 M9	9.0	7.0	-9236K	4893.00
107	M10 M10	7.0	5.5	-9226K	4893.00
1010	M10 M10	10.0	8.0	-9280K	5149.00
11862	M11 M11	8.0	6.2	-9240K	4893.00
129	M12 M12	9.0	7.0	-9228K	4893.00

Size (d) SC31/2	For DIN Taps	Dimensions Shank	Dimensions A/F	Order Code IND-144	Price/1 TB
6649	M6 M6	6.0	4.9	-9314K	6179.00
8649	M8 M8	6.0	4.9	-9316K	6179.00
88	M8 M8	8.0	6.2	-9300K	6179.00
997	M9 M9	9.0	7.0	-9306K	6179.00
107	M10 M10	7.0	5.5	-9302K	6179.00
1010	M10 M10	10.0	8.0	-9360K	6179.00
11862	M11 M11	8.0	6.2	-9318K	6179.00
129	M12 M12	9.0	7.0	-9304K	6179.00
1411	M14 M14	11.0	9.0	-9308K	6179.00
1612	M16 M16	12.0	9.0	-9310K	6179.00
181411	M18 M18	14.0	11.0	-9320K	6179.00
2016	M20 M20	16.0	12.0	-9312K	6179.00

Size (d) SC19/1	For ISO 529 Taps	Dimensions Shank	Dimensions A/F	Order Code IND-144	Price/1 TB
Metric	UNC/UNF BSW/BSF BA/BSP				
3315	M3 4 / 5 1/8" 5BA	3.15	2.50	-9274K	5149.00
0044	M4 5/32"	4.00	3.15	-9260K	5149.00
0046	M4.5 8 3BA	4.50	3.55	-9262K	5149.00
55	M5 10 3/16" 2BA	5.00	4.00	-9270K	5149.00
0053	M5.5 12 7/32" 1BA	5.60	4.50	-9268K	5149.00
663	M6 1/4" 1/4" OBA	6.30	5.00	-9272K	5149.00
0082	M8 5/16" 5/16"	8.00	6.30	-9264K	5149.00
1010	M10 3/8" 3/8"	10.00	8.00	-9280K	5149.00
0121	M12 1/2" 1/2"	9.00	7.10	-9266K	5149.00

Size (d) SC31/2	For ISO 529 Taps	Dimensions Shank	Dimensions A/F	Order Code IND-144	Price/1 TB
Metric	UNC/UNF BSW/BSF BA/BSP				
663	M6 1/4" 1/4" OBA	6.3	5.0	-9346K	6438.00
0082	M8 5/16" 5/16"	8.0	6.3	-9340K	6438.00
1010	M10 3/8" 3/8"	10.0	8.0	-9360K	6179.00
0121	M12 1/2" 1/2"	9.0	7.1	-9344K	6438.00
14112	M14 9/16" 9/16"	11.2	9.0	-9352K	6438.00
16125	M16 5/8" 5/8"	12.5	10.0	-9354K	6438.00
1814112	M18 1" 1"	14.0	11.2	-9356K	6438.00
2014	M20 3/4" 3/4"	14.0	11.2	-9348K	6438.00
2216	M22 7/8" 7/8"	16.0	12.5	-9350K	6438.00
001814	M24 1" 1"	18.0	14.0	-9342K	6438.00



INDEXA-SEIKI Tapping Chucks - Rigid Type (No Compression)

With through coolant. Suitable for use on CNC machines set up for rigid tapping.

ISO/DIN 69871-A Taper Shank

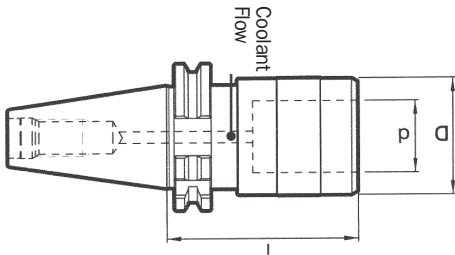

Collet Size (d)	Shank Size	Dimensions		Tapping Range	Order Code IND-144	Price/1 TB
SC19	DN40	33.0	59	M3-M12	-8530K	19500.00
	DN50	33.0	75	M3-M12	-8540K	14008.00
SC31	DN40	50.0	86	M6-M20	-8532K	12875.00
	DN50	50.0	98	M6-M20	-8542K	15965.00

MAS 403 BT Taper Shank

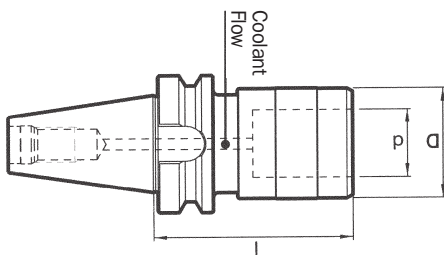

Collet Size (d)	Shank Size	Dimensions		Tapping Range	Order Code IND-144	Price/1 TB
SC19	BT40	33.0	67	M3-M12	-8510K	14419.00
	BT50	33.0	78	M3-M12	-8520K	17768.00
SC31	BT40	50.0	90	M6-M20	-8512K	14935.00

Tapping Collets

Rigid type. To suit Rigid Type tapping chucks shown above.

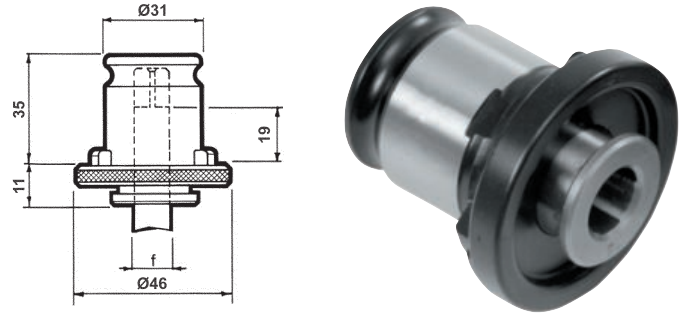
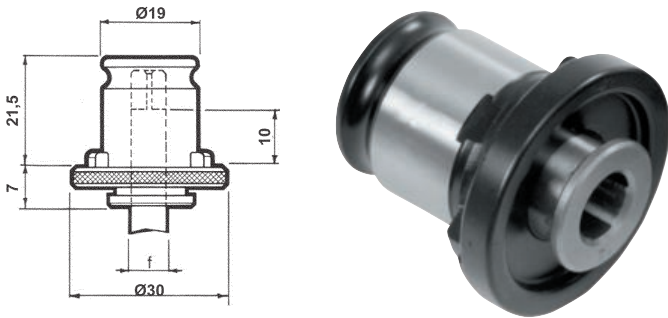

Size (d)	For DIN Taps				Dimensions		Order Code	Price/1
SC19/11	352	371	374	376	Shank	A/F	IND-144	TB
3527	M3	M3	M5	M5	3.5	2.7	-9108K	1700.00
4534	M4	M4			4.5	3.4	-9110K	1700.00
649	M5-M8	M5-M6	M8	M8	6.0	4.9	-9102K	1700.00
862	M8	M11	M11		8.0	6.2	-9106K	1700.00
755	M10	M7	M10	M10	7.0	5.5	-9104K	1700.00
97	M12	M9	M12	M12	9.0	7.0	-9100K	1700.00
108		M10			10.0	8.0	-9140K	1957.00

Size (d)	For DIN Taps				Dimensions		Order Code	Price/1
SC31/12	352	371	374	376	Shank	A/F	IND-144	TB
649	M5-M8	M5-M6	M8	M8	6.0	4.9	-9166K	2575.00
862	M11	M8	M11	M11	8.0	6.2	-9170K	2575.00
97	M12	M9	M12	M12	9.0	7.0	-9160K	2575.00
755	M10		M10	M10	7.0	5.5	-9168K	2575.00
108		M10			10.0	8.0	-9200K	2575.00
119	M14		M14	M14	11.0	9.0	-9162K	2575.00
129	M16		M16	M16	12.0	9.0	-9164K	2575.00
1411	M18		M18	M18	14.0	11.0	-9172K	2575.00
1612	M20		M20	M20	16.0	12.0	-9174K	2575.00

Size (d)	For ISO 529 Taps				Dimensions		Order Code	Price/1
SC19/11	Metric	UNC/UNF	BSW/BSF	BA	Shank	A/F	IND-144	TB
31525	M3	4/5	1/8"	5BA	3.15	2.50	-9132K	1957.00
0044	M4		5/32"		4.00	3.15	-9120K	1957.00
0046	M4.5	8		3BA	4.50	3.55	-9122K	1957.00
54	M5	10	3/16"	2BA	5.00	4.00	-9128K	1957.00
635	M6	1/4"	1/4"	OBA	6.30	5.00	-9130K	1957.00
0082	M8/M11	5/16"/7/16"	5/16"/7/16"		8.00	6.30	-9124K	1957.00
0121	M9/M12	1/2"	1/2"		9.00	7.10	-9126K	1957.00
108	M10	3/8"	3/8"		10.00	8.00	-9140K	1957.00

Size (d)	For ISO 529 Taps				Dimensions		Order Code	Price/1
SC31/12	Metric	UNC/UNF	BSW/BSF	BA/BSP	Shank	A/F	IND-144	TB
635	M6	1/4"	1/4"	OBA	6.3	5.0	-9184K	2575.00
755	M7				7.0	5.5	-9186K	2575.00
0082	M8/M11	5/16"/7/16"	5/16"/7/16"	1/8" BSP	8.0	6.3	-9180K	2575.00
0121	M9/M12	1/2"	1/2"		9.0	7.1	-9182K	2575.00
108	M10	3/8"	3/8"	1/4" BSP	10.0	8.0	-9200K	2575.00
1129	M14	9/16"	9/16"		11.2	9.0	-9188K	2575.00
12510	M16	5/8"	5/8"	3/8" BSP	12.5	10.0	-9192K	2575.00
14112	M18/M20	3/4"	3/4"		14.0	11.2	-9194K	2575.00
16125	M22	7/8"	7/8"		16.0	12.5	-9196K	2575.00
1814	M24	1"	1"	5/8" BSP	18.0	14.0	-9190K	2575.00



GROUP 200 ABRASIVE SHEETS & COILS

 Page **166 - 167**

GROUP 201 ABRASIVE SPONGES

 Page **167**

GROUP 202 FIBRE BACKED DISCS

 Page **168**

GROUP 203 HOOK-N-LOOP BACKED DISCS

 Page **169**

GROUP 204 SANDING BELTS

 Page **170**

GROUP 205 SANDING BANDS & CARTRIDGE ROLLS

 Page **171 - 172**

GROUP 205 SURFACE PREPARATION

 Page **173**

GROUP 210 CARBIDE & DIAMOND BURRS

 Page **174 - 177**

GROUP 220 FLAP DISCS & FLAP WHEELS

 Page **178 - 179**

GROUP 230 CUTTING & GRINDING DISCS

 Page **180 - 181**

GROUP 235 GRINDING WHEELS

 Page **182 - 183**

GROUP 240 JIGSAW BLADES

 Page **184 - 185**

GROUP 245 FIBRE ABRASIVES

 Page **186 - 187**

GROUP 247 POLISHING & LAPPING

 Page **188 - 189**

GROUP 250 MOUNTED POINTS

 Page **190 - 191**

GROUP 255 OILSTONES

 Page **192 - 193**

GROUP 257 GRINDING COMPOUNDS

 Page **188**

GROUP 259 AIR PRODUCTS

 Page **194 - 201**

GROUP 261 BENCH GRINDERS

 Page **232**

GROUP 268 MAGNETIC DRILLING MACHINES

 Page **202 - 203**

GROUP 270 AIR TOOLS

 Page **204 - 221**

GROUP 271 MACHINE TOOLS

 Page **222 - 223**

GROUP 273 COMPRESSORS & GENERATORS

 Page **224**

GROUP 279 PRESSURE WASHERS

 Page **225**

GROUP 279 DIY POWER TOOLS

 Page **226 - 227**

GROUP 279 WATER PUMPS

 Page **225**

GROUP 279 INDUSTRIAL POWER TOOLS

 Page **228 - 233**

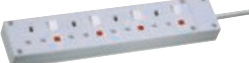
GROUP 281 CABLE REELS, PLUGS & SOCKETS

 Page **236**

GROUP 282 LIGHTING

 Page **237**

GROUP 287 ROUTER CUTTERS

 Page **238**

GROUP 288 MULTI-TOOTH DRILLING CUTTERS

 Page **203**

GROUP 289 POWER TOOL CHISELS

 Page **239**

GROUP 291 PUSH-FIT PNEUMATIC FITTINGS

 Page **240 - 241**

GROUP 295 WIRE WHEELS & BRUSHES

 Page **242 - 243**



ABRASIVES & POWER TOOLS

Product Groups
200 - 295

Product Grading



Production

High performance industrial tooling designed for continuous use applications on machine tools where repeatability and long tool life are of critical importance.



Professional

Industrial tooling that has enhanced features and benefits demanded by craftsmen and professional users.



Industrial

Designed for regular use in industrial applications. Manufactured to stringent quality levels and international standards.



Workshop

Standard quality tooling for use by tradesmen and generally industrial use.



Maintenance

Products designed for general maintenance of machines, workshops, garages and some household applications.



Home Improver

DIY quality tooling. Designed for home use and light industrial applications.

Contents

Abrasives

Description	Group	Page
Abrasive Coated Sponges	201	167
Abrasive Sheets & Coils	200	166 - 167
Carbide Burrs	210	174 - 177
Cartridge Rolls	205	172
Cutting & Grinding Discs	230	180 - 181
Diamond Coated Burrs	210	177
Fibre Abrasives	245	186 - 187
Felt Bobs	247	188
Flap Discs	220	179
Flap Wheels	220	178
Grinding Compounds	257	188
Grinding Wheels	235	182 - 183
Jigsaw Blades	240	184 - 185
Mandrels	205	171
Mounted Points	250	190 - 191
Oilstones	255	192 - 193
Polishing & Lapping	247	188 - 189
Pre-finish & Polishing Bars	247	188
Sanding Bands	205	171
Sanding Belts	204	170
Sanding Discs - Fibre Backed	202	168
Sanding Discs - Hook-n-Loop Backed	203	169
Surface Preparation Products	205	173

Power Tools & Accessories

Description	Group	Page
Air Hose & Balancers	258	194
Air Tools - Drills	270	205 - 207
- Grinders	270	208 - 212
- Hammers	270	213
- Nibblers, Saws & Shears	270	214
- Polishers	270	216 - 217
- Sanders	270	216 - 218
- Screwdrivers	270	215
- Wrenches	270	219 - 221
Airline Accessories	259	195 - 199
Bench Grinder	261	232
Blow Guns	259	200
Cable Reels, Plugs & Sockets	281	236
Compressors	273	224
DIY Power Tools	279	226 - 227
Engravers	279	226
Generators	273	224
Industrial Power Tools	279	228 - 233
Lighting	282	237
Machine Tools	271	222 - 223
Magnetic Drilling Cutters	288	203
Magnetic Drilling Machines	268	202 - 203
Multi-tools	279	226
Pillar Drills	271	223
Power Tool Chisels	289	239
Pressure Washers	279	225
Push-Fit Pneumatic Fittings	291	240 - 241
Router Cutters	287	238
Spray Guns	259	201
Wire Wheels & Brushes	295	242 - 243

GROUP 200 ABRASIVE SHEETS & COILS

KENNEDY SANDING SHEETS
QUALITY INDUSTRIAL TOOLING

Industrial aluminium oxide sanding paper is 'glue' bonded and suitable for use with hand sanding blocks and orbital sanders.



PACK OF 25

Grit	Weight per 25	Order Code KEN-200	Price/25 TB
1/3 Sheet (93mm Wide x 230mm Long)			
P80 Med	290g	-9150K	264.00
P50 Cse	330g	-9190K	264.00
1/2 Sheet (115mm Wide x 280mm Long)			
P120 Fine	400g	-9410K	332.00
P80 Med	380g	-9450K	332.00
P50 Cse	570g	-9490K	332.00

1/4 Sheet Hand Sanding Pad

Made from compound rubber. With curved and flat sides. Complete with locating spikes.

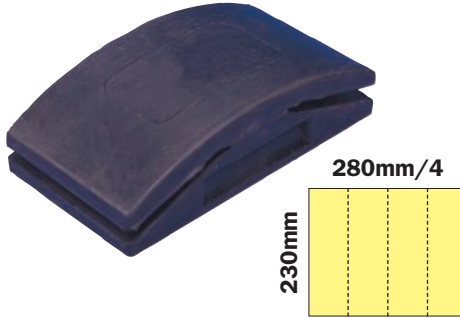

Suitable for all types of coated abrasive sheets. Accepts a standard 230 x 280mm sheet split down into quarters across the width, as shown.

Width x Length x Height (mm)	Weight each	Order Code KEN-280	Price/1 TB
70 x 125 x 35	360g	-4100K	152.00

Aluminium Oxide Cloth



Superflex aluminium oxide is 'resin bonded over resin' on a very flexible J-weight blue twill cloth. Moisture resistant and electrostatically coated for polishing flat and contoured surfaces in most materials.

Rolls



Grit	Weight each	Order Code KEN-200	Price/1 TB
25mm Wide x 50m Long			
P40	1.65kg	-2210K	1502.00
P60	1.20kg	-2170K	1502.00
P80	0.95kg	-2150K	1277.00
P100	1.00kg	-2130K	1277.00
P120	0.80kg	-2110K	1277.00
P150	0.70kg	-2090K	1277.00
P180	0.70kg	-2080K	1277.00
P220	0.70kg	-2070K	1277.00
P240	0.65kg	-2060K	1277.00
P280	0.55kg	-2050K	1277.00
P320	0.60kg	-2030K	1277.00
38mm Wide x 50m Long			
P60	2.00kg	-2470K	2502.00
P80	1.70kg	-2450K	2285.00
P100	1.40kg	-2430K	2121.00
P120	1.30kg	-2410K	2121.00
P150	1.10kg	-2390K	2121.00
P220	1.15kg	-2370K	2287.00
50mm Wide x 50m Long			
P40	3.35kg	-2810K	2691.00
P60	2.30kg	-2770K	2691.00
P80	2.10kg	-2750K	2189.00
P100	1.60kg	-2730K	2189.00
P120	1.60kg	-2710K	2189.00
P150	1.40kg	-2690K	2189.00
P180	1.60kg	-2680K	2189.00
P220	1.30kg	-2670K	2189.00
P240	1.30kg	-2660K	2189.00
P320	1.15kg	-2630K	2189.00

Sheets

Size: 230 x 280mm (9" x 11"). Supplied in packs of 50.



PACK OF 50

Grit	Weight per 50	Order Code KEN-200	Price/50 TB
230mm Wide x 280mm Long			
P40	4.00kg	-3210K	3166.00
P50	3.25kg	-3190K	3166.00
P60	3.20kg	-3170K	2378.00
P80	2.70kg	-3150K	2378.00
P100	2.25kg	-3130K	2189.00
P120	2.10kg	-3110K	2189.00
P150	1.95kg	-3090K	2189.00
P180	1.85kg	-3080K	2189.00
P220	1.75kg	-3070K	3691.00
P240	1.70kg	-3060K	1877.00
P280	1.75kg	-3050K	1877.00
P320	1.50kg	-3030K	2189.00

SENATOR GLASS PAPER
QUALITY TOOLING

Suitable for joinery and general woodworking use ideal for surface preparation prior to painting.

Size: 230mm wide x 280mm long.



PACK OF 50

Grit	Order Code SEN-200	Price/50 TB
00	-8010K	236.00
0	-8020K	236.00
1	-8030K	236.00
1.5	-8040K	236.00
F2	-8060K	236.00
M2	-8070K	236.00
S2	-8080K	236.00

Assorted Sheets Glass Paper (pk 5) -8100K 190.00

Assorted Emery Strips

Approximately 100 strips of assorted grades. Suitable for a variety of industrial, garage and workshop applications.

Size: 1" (25mm) x 10" (250mm).



100 PIECES

Strip Size	Pack Quantity	Order Code SEN-200	Price/1 TB
25 x 250	100 (approx)	-9000K	980.00

Aluminium Oxide Cloth

Aluminium oxide resinoid, cloth backed, X-weight for workshop use.

Rolls



Grit	Order Code SEN-200	Price/1 TB
25mm Wide x 46m Long		
P60	-2170K	427.00
P120	-2110K	415.00
P180	-2080K	407.00
P240	-2060K	389.00

Sheets

Size: 230 x 280mm (9" x 11"). Supplied in packs of 25.



PACK OF 25

Grit	Order Code SEN-200	Price/25 TB
230mm Wide x 280mm Long		
P60	-4010K	439.00
P120	-4030K	369.00
P180	-4050K	369.00
P240	-4070K	369.00

KENNEDY *Economy Emery Cloth*
QUALITY INDUSTRIAL TOOLING

Blue twill economy emery is 'glue bonded' to a very flexible J-weight blue twill cloth. Suitable for general-purpose, light duty workshop use.



Rolls			
Grit	Weight each	Order Code KEN-200	Price/1 TB
25mm Wide x 50m Long			
P40 (3)	1.30kg	-0210K	502.00
P50 (2.5)	1.30kg	-0190K	502.00
P60 (2)	1.20kg	-0170K	502.00
P80 (1.5)	0.90kg	-0150K	502.00
P100 (1)	0.90kg	-0130K	502.00
P120 (F)	0.75kg	-0110K	502.00
P150 (FF)	0.60kg	-0090K	463.00
P220 (O)	0.50kg	-0070K	451.00
P280 (OO)	0.50kg	-0050K	451.00
38mm Wide x 50m Long			
P50 (2.5)	1.70kg	-0490K	617.00
P60 (2)	1.50kg	-0470K	617.00
P80 (1.5)	0.95kg	-0450K	617.00
P100 (1)	1.10kg	-0430K	603.00
P120 (F)	1.00kg	-0410K	603.00
P150 (FF)	1.00kg	-0390K	603.00
P220 (O)	0.70kg	-0370K	603.00
50mm Wide x 50m Long			
P40 (3)	2.40kg	-0810K	908.00
P50 (2.5)	2.10kg	-0790K	908.00
P60 (2)	1.90kg	-0770K	908.00
P80 (1.5)	1.70kg	-0750K	908.00
P100 (1)	1.80kg	-0730K	908.00
P120 (F)	1.20kg	-0710K	889.00
P150 (FF)	1.20kg	-0690K	889.00
P220 (O)	0.90kg	-0670K	783.00
P280 (OO)	0.90kg	-0650K	783.00

Sheets
230 x 280mm (9" x 11").
Supplied in packs of 50.



Grit	Weight per 50	Order Code KEN-200	Price/50 TB
P40 (3)	3.35kg	-1210K	2065.00
P50 (2.5)	3.00kg	-1190K	2065.00
P60 (2)	2.50kg	-1170K	2065.00
P80 (1.5)	1.80kg	-1150K	2065.00
P100 (1)	2.20kg	-1130K	1854.00
P120 (F)	1.80kg	-1110K	1854.00
P150 (FF)	1.25kg	-1090K	1854.00
P220 (O)	1.60kg	-1070K	1854.00
P280 (OO)	1.15kg	-1050K	1854.00

ABRASIVE SHEETS, COILS & SPONGES

Wet or Dry Silicon Carbide Paper

Silicon carbide is waterproof-resin bonded to paper suitable for wet and dry production polishing and finishing of a wide range of materials including metals, plastics, paintwork, ceramics etc. Supplied in packs of 50.



PACK OF 50			
Grit	Weight per 50	Order Code KEN-200	Price/100 TB
230mm Wide x 280mm Long			
P60	2.00kg	-7060K	2189.00
P80	1.65kg	-7080K	1877.00
P100	1.55kg	-7100K	2502.00
P120	1.50kg	-7120K	1854.00
P150	1.25kg	-7140K	1854.00
P180	1.20kg	-7160K	2189.00
P220	1.10kg	-7180K	1790.00
P240	1.00kg	-7200K	2189.00
P280	0.95kg	-7220K	1940.00
P320	0.85kg	-7240K	1940.00
P360	0.80kg	-7260K	2627.00
P400	0.70kg	-7280K	1940.00
P500	0.65kg	-7300K	1940.00
P600	0.60kg	-7320K	2065.00
P800	0.55kg	-7340K	1940.00
P1000	0.55kg	-7360K	2065.00
P1200	0.55kg	-7380K	1940.00

SENATOR QUALITY TOOLING

Wet & Dry Sheet Kit

Silicon carbide. Waterproof-resin bonded paper. Suitable for wet and dry applications. For metal and wood giving a high quality surface preparation and an excellent key for following coats.

Contents Pack of 25 (5 of each):
P180, P240, P320, P400, P600.
All sheets 230 x 280mm.

PACK OF 25			
Grit	Weight per 25	Order Code SEN-200	Price/Pk TB
Mixed	370g	-8200K	361.00

YORK ABRASIVES Flexible Abrasives

Abrasive covered foam for general-purpose sanding on wood.

Double-Sided Blocks Square End

Abrasive coated semi-flexible sponge, coated on all four surfaces. Suitable for sanding 90° contoured surfaces. Available in four different grades.

Size: 56 x 69 x 25mm.

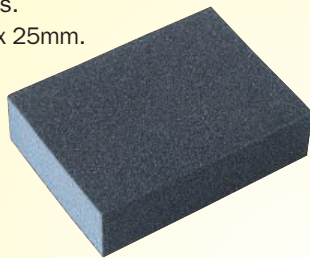

Grade	Weight each	Order Code YRK-201	Price/100 TB
Fine	21g	-9000K	2502.00
Fine/Medium	23g	-9010K	2502.00
Medium	27g	-9020K	2502.00
Medium/Coarse	29g	-9030K	2502.00

Chamfered Sanding Block

Semi-flexible abrasive coated sponge. The different surface angles allow awkwardly contoured wooden surfaces to be easily sanded. Available in two different grades.

Size: 97 x 45/70 x 21mm.

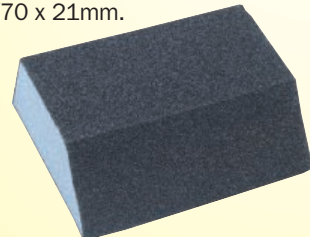

Grade	Weight each	Order Code YRK-201	Price/100 TB
Medium	20g	-8310K	3534.00
Fine	14g	-8320K	3534.00

Al-Ox

Single-Sided Pads

Single-sided highly flexible abrasive coated sponge pad. Will conform to the shape of any contoured surface. Available in three different grades.

Size: 140 x 110 x 5mm.

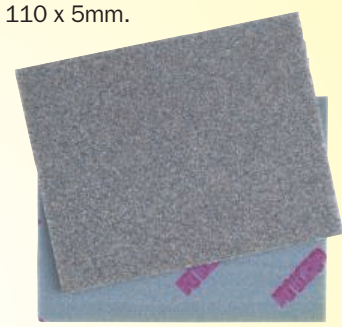

Grade	Weight each	Order Code YRK-201	Price/100 TB
Medium	15g	-9510K	6309.00
Fine	13g	-9520K	3763.00

Double Sided Pads

Flexible abrasive coated sponge pads will conform to most contoured surface shape. Coated with abrasive on both sides. Available in two different grades.

Size: 120 x 96 x 12.5mm.

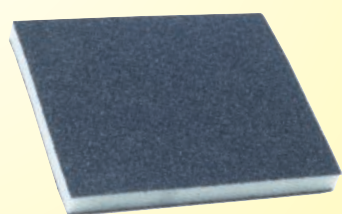

Grade	Weight each	Order Code YRK-201	Price/100 TB
Medium	18g	-9310K	2378.00
Fine	11g	-9320K	2127.00

GROUP 202 SANDING DISCS - FIBRE BACKED



Fibre Discs



Fibre Discs



Adhesive Backed Discs



Aluminium Oxide General-Purpose Grade

Al-Ox

Resin fibre backed sanding discs are designed for a wide range of industrial applications. High speed penetration of tough and high tensile materials combined with long disc life and optimum flexibility ensure York sanding discs give first class performance every time. Recommended for use with all portable grinders and sanders.



Grit	Weight per 100	Order Code YRK-202	Price/100 TB
100mm Diameter x 16mm Bore Max 12,400rpm			
P24	0.55kg	-2010K	3155.00
P36	0.55kg	-2030K	3155.00
P50	0.45kg	-2050K	2611.00
P60	0.45kg	-2060K	2611.00
P80	0.40kg	-2070K	2611.00
P100	0.35kg	-2080K	2627.00
P120	0.35kg	-2090K	2627.00
115mm Diameter x 22mm Bore Max 11,000rpm			
P24	1.70kg	-2110K	3753.00
P36	1.65kg	-2130K	3753.00
P50	1.60kg	-2150K	3753.00
P60	1.55kg	-2160K	3753.00
P80	1.50kg	-2170K	3753.00
P100	1.50kg	-2180K	3753.00
P120	1.45kg	-2190K	3753.00
178mm Diameter x 22mm Bore Max 7,000rpm			
P24	1.95kg	-2410K	8171.00
P36	1.80kg	-2430K	7782.00
P50	1.55kg	-2450K	6803.00
P60	1.55kg	-2460K	6803.00
P80	1.40kg	-2470K	6406.00
P120	1.30kg	-2490K	6406.00

Zirconium Stainless Steel Grade

Zirc

The zirconia grain is supported by grinding additives which lubricate and cool the area being ground and help prevent clogging, prolonging the effective life of the disc. Suitable for use on all types of stainless steels, weld seams castings and other sophisticated metals for extended periods, removing large amounts of metal without excess heat build up.

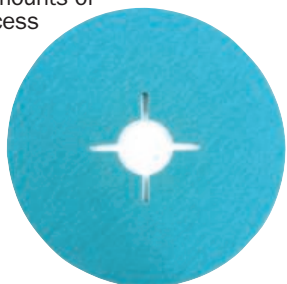

Grit	Weight per 25	Order Code YRK-202	Price/100 TB
115mm Diameter x 22mm Bore Max 13,300rpm			
P36	0.65kg	-4130K	6091.00
P50	0.60kg	-4150K	5655.00
P60	0.55kg	-4160K	5384.00
P80	0.80kg	-4170K	5112.00
P100	0.50kg	-4180K	5112.00
P120	0.45kg	-4190K	5112.00

Aluminium Oxide

Designed for a wide range of applications. High speed penetration of tough and high tensile materials combined with long disc life and optimum flexibility ensure Kennedy sanding discs give first class performance every time. Recommended for use with all portable grinders and sanders.



Grit	Weight per 25	Order Code KEN-202	Price/100 TB
100mm Diameter x 16mm Bore Max 12,400rpm			
P24	0.55kg	-2010K	3155.00
P36	0.55kg	-2030K	3155.00
P50	0.45kg	-2050K	2611.00
P60	0.45kg	-2060K	2611.00
P80	0.40kg	-2070K	2611.00
P100	0.35kg	-2080K	2627.00
P120	0.35kg	-2090K	2627.00
115mm Diameter x 22mm Bore Max 11,000rpm			
P24	0.70kg	-2110K	3753.00
P36	0.65kg	-2130K	3753.00
P50	0.60kg	-2150K	3753.00
P60	0.55kg	-2160K	3753.00
P80	0.50kg	-2170K	3753.00
P100	0.50kg	-2180K	3753.00
P120	0.45kg	-2190K	3753.00
127mm Diameter x 22mm Bore Max 10,000rpm			
P24	0.70kg	-2210K	4297.00
P36	0.80kg	-2230K	4187.00
P50	0.70kg	-2250K	4133.00
P60	0.70kg	-2260K	3916.00
P80	0.60kg	-2270K	3862.00
P100	0.60kg	-2280K	3862.00
P120	0.60kg	-2290K	3862.00
178mm Diameter x 22mm Bore Max 7,000rpm			
P24	1.95kg	-2410K	8169.00
P36	1.80kg	-2430K	7782.00
P50	1.55kg	-2450K	4941.00
P60	1.55kg	-2460K	6803.00
P80	1.40kg	-2470K	6406.00
P100	1.35kg	-2480K	6406.00
P120	1.25kg	-2490K	6406.00



Fibre Disc Kit



Al-Ox

Aluminium Oxide resin-backed fibre. Long disc life. Optimum flexibility. For metal and wood. For use with portable grinders and sanders.

Contents:

5 each of P24, P36, P60, P80, P120. All discs - 115 x 22mm. Pack of 25 discs.



PACK OF 25

Grit	Weight per 25	Order Code SEN-202	Price/Pk TB
Mixed	0.45kg	-8500K	435.00

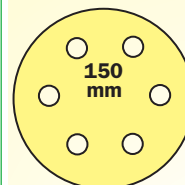

BEST SELLER

Hole Pattern: 600A. 6 Hole.

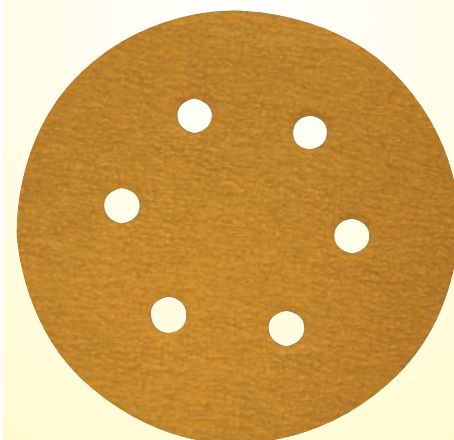

Grade	Weight per 100	Order Code YRK-202	Price/100 TB
P60	540g	-6360K	2252.00
P80	490g	-6370K	2252.00
P100	440g	-6380K	2252.00
P120	420g	-6390K	2252.00
P150	400g	-6400K	2252.00
P180	350g	-6410K	2252.00
P220	350g	-6420K	2252.00

Self-stick Backing Pads



For use with rotary and orbital sanders. The 125mm pad can be used for discs with or without holes

Thread size: 5/16" x UNF male.



To Suit Disc	Hole Configuration	Order Code KEN-280	Price/1 TB
150mm	No Hole	-3870K	1029.00
	6 Hole	-3920K	944.00

KOBE

Hook-n-Loop Backed Sanding Discs

No spanners required. 100% of disc can be used, material removal rate is therefore increased. Can be repeatedly removed and re-applied. Silicon carbide abrasive especially suitable for automotive body preparation prior to spraying and for cutting back two-pack paint finishes. Can be used wet or dry.



Disc Diameter	Grade	Pack Qty	Order Code KBE-280	Price/Pk TB
50mm (2")	320	25	-0203A	504.00
	400		-0204A	504.00
	600		-0205A	504.00
75mm (3")	320	25	-0206A	921.00
	400		-0207A	921.00
	600		-0208A	921.00

Flexible Backing Pads for Hook-n-Loop Sanding Discs

Suitable for use with Kobe Hook-n-Loop sanding discs for rapid disc changing.

Thread size: M6.



To Suit Disc	Hole Configuration	Order Code KBE-280	Price/1 TB
50mm	No Hole	-0201A	882.00
75mm	No Hole	-0202A	882.00

YORK ABRASIVES

Hook-n-Loop Backed Sanding Sheets

Aluminium oxide abrasive 'resin-bonded over resin' to Hook-n-Loop backed paper suitable for wood, plastics and ceramics etc.

Size: 165 x 75mm.

7 Hole. Dust Extraction Type.

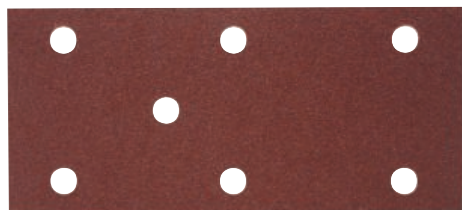

Grit	Order Code YRK-200	Price/100 TB
P60	-1560K	2815.00
P80	-1570K	2815.00
P100	-1580K	2815.00
P120	-1590K	2815.00
P180	-1610K	2815.00



KENNEDY QUALITY INDUSTRIAL TOOLING

Hook-n-Loop Sanding Discs

No spanners required. 100% of sanding disc can be used. Can be removed and re-applied. Unaffected by dust or moisture. Aluminium oxide abrasive 'resin-bonded over resin' to Hook-n-Loop backed paper suitable for wood, plastics, ceramics.

Plain (no holes).

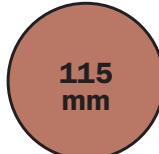

Grit	Weight per 100	Order Code KEN-203	Price/100 TB
P40	360g	-2040K	2285.00
P60	340g	-2060K	2121.00
P80	290g	-2070K	2121.00
P120	240g	-2090K	2176.00

Plain (no holes).

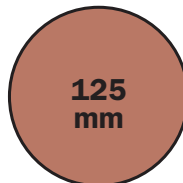

Grit	Weight per 100	Order Code KEN-203	Price/100 TB
P40	510g	-2240K	2720.00
P60	410g	-2260K	2611.00
P80	340g	-2270K	2557.00
P120	260g	-2290K	2448.00

Plain (no holes).

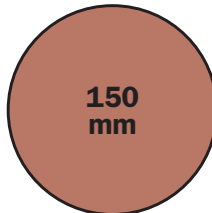

Grit	Weight per 100	Order Code KEN-203	Price/100 TB
P40	630g	-2440K	3373.00
P60	570g	-2460K	3209.00
P80	440g	-2470K	3264.00
P120	390g	-2490K	3317.00

Flexible Backing Pads for Hook-n-Loop Sanding Discs

Suitable for use with Kennedy Hook-n-Loop sanding discs.

Thread size: 150mm: 5/16" x UNF male. 125mm: M14 x 2.0



To Suit Disc	Hole Configuration	Order Code KEN-280	Price/1 TB
125mm	No Hole	-3230K	1005.00
150mm	No Hole	-3370K	1029.00
	6 Hole	-3390K	1029.00



Hole Pattern: 800A. 8 Hole.

To suit PEX115, PEX9.6, Kress.

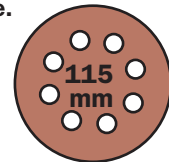

Grit	Weight per 100	Order Code KEN-203	Price/100 TB
P60	330g	-2160K	2665.00
P80	260g	-2170K	2557.00
P120	220g	-2190K	2557.00

Pattern: 600A. 6 Hole.

To suit Flex, Kress, PEX15 PEX9.6.

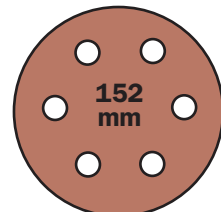

Grit	Weight per 100	Order Code KEN-203	Price/100 TB
P40	690g	-2540K	3373.00
P60	540g	-2560K	3209.00
P80	470g	-2570K	3100.00
P120	360g	-2590K	3317.00

Hook-n-Loop Backed Delta Sheets

Aluminium oxide abrasive 'resin-bonded over resin' to Hook-n-Loop backed paper suitable for wood, plastics and ceramics etc.

Size: 94 x 94 x 94mm.

6 Hole Delta Dust Extraction Type.



PACK OF 50

Grit	Weight per 250	Order Code KEN-203	Price/50 TB
P40	300g	-6040K	1469.00
P60	280g	-6060K	1360.00
P80	230g	-6070K	1252.00
P100	190g	-6080K	1252.00
P400	160g	-6140K	1252.00

Delta Sheet Pack

Aluminium oxide abrasive 'resin-bonded over resin' to Hook-n-Loop backed paper suitable for wood, plastics, ceramics etc.



PACK OF 10

Contents (Quantity x Grit)	Weight per 10	Order Code KEN-203	Price/Pk TB
2x P40, 3x P60, 2x P80, 3x P100	36g	-6500K	218.00

GROUP 204 SANDING BELTS

YORK ABRASIVES Sanding Sticks & Belts

The ideal tool for those awkward finishing jobs, the spring loaded holders combine with standard sanding belts to become a simple but effective lapping tool.

Belts are suitable for use on wood and metal

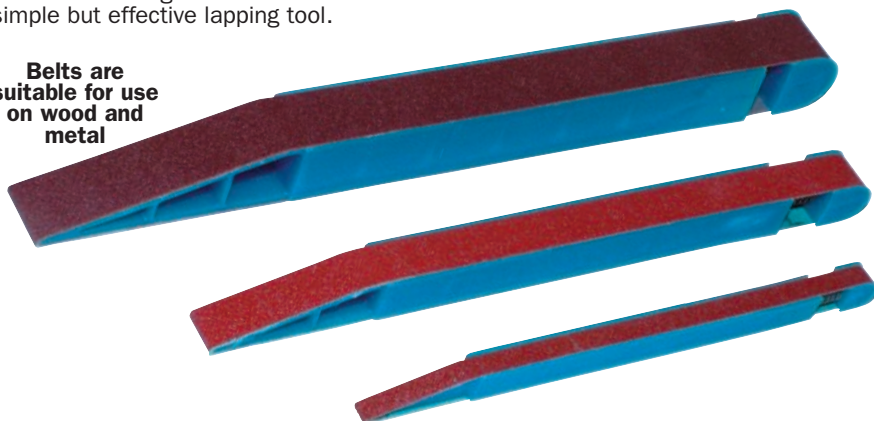

Sanding Sticks

To Suit Belt Size	Order Code YRK-204	Price/1 TB
6mm x 330	-9060K	183.00
12mm x 420	-9120K	226.00
20mm x 520	-9190K	361.00

Set Contents:

- 1 - 6mm sanding stick,
- 1 - 12mm sanding stick,
- 1 - 19mm sanding stick,
- 2 - 6mm x 330mm P120 sanding belts,
- 2 - 12mm x 420mm P120 sanding belts,
- 2 - 19mm x 520mm P120 sanding belts.

9 PIECES

Number of Pieces	Order Code YRK-204	Price/1 TB
9	-9500K	876.00

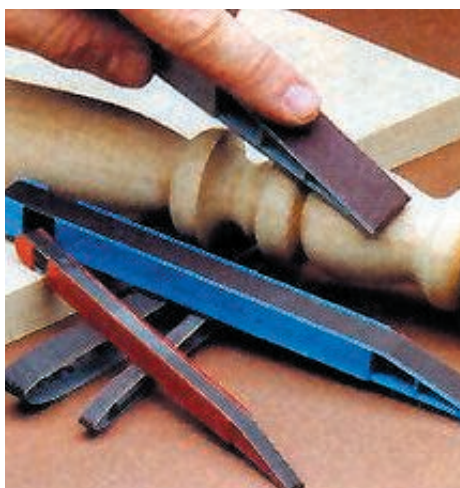

KENNEDY Portable Sander Belts

Resin bond aluminium oxide sanding belts are designed for industrial applications. Durability combined with flexibility ensures a long life and first class performance. Suitable for wood and metal work.

Al-Ox

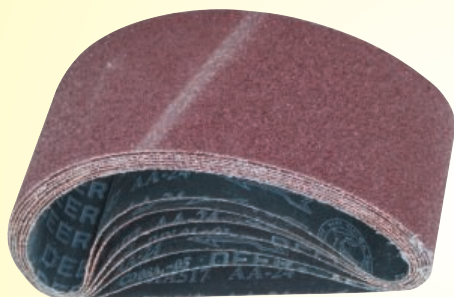

100mm (4") Wide x 610mm (24") Long

Grit	Weight per 10	Order Code KEN-204	Price/10 TB
P24	1,100g	-0540K	1189.00
P36	870g	-0560K	1189.00
P40	880g	-0580K	1189.00
P50	790g	-0600K	1220.00
P60	750g	-0620K	1189.00
P80	700g	-0640K	1189.00
P100	550g	-0660K	1189.00
P120	580g	-0680K	1189.00
P150	490g	-0700K	1220.00
P180	520g	-0720K	1220.00
P240	500g	-0760K	1220.00
P320	480g	-0780K	1220.00

Linisher Belts

Resin bond aluminium oxide sanding belts are designed for industrial applications. Durability combined with flexibility ensures a long life and first class performance. Suitable for wood and metal work.

Al-Ox



Grit	Weight per 10	Order Code KEN-204	Price/10 TB
100mm (4") Wide x 915mm (36") Long			
P24	2.15kg	-1040K	1877.00
P36	1.80kg	-1060K	1877.00
P40	1.55kg	-1080K	1877.00
P50	1.40kg	-1100K	1877.00
P60	1.30kg	-1120K	1877.00
P80	1.20kg	-1140K	1877.00
P100	1.00kg	-1160K	1877.00
P120	0.95kg	-1180K	1877.00
P150	0.90kg	-1200K	1877.00
P180	0.90kg	-1220K	1877.00
P220	0.85kg	-1240K	1877.00
P240	0.85kg	-1260K	1877.00
P320	0.80kg	-1280K	1877.00

File Belts

Suitable for a wide range of power tools. Aluminium oxide designed for a wide range of materials including metal, steel, aluminium and non-ferrous metals.

Al-Ox



EXTENDED RANGE

Size (mm) W x L	Grit	Order Code YRK-204	Price/100 TB
6 x 330	P36	-4060K	2189.00
	P60	-4120K	2752.00
	P80	-4140K	2752.00
	P100	-4160K	2752.00
	P120	-4180K	2752.00
	P150	-4200K	2752.00
6 x 457	P240	-4240K	2270.00
	P150	-3202K	4119.00
6 x 610	P60	-3240K	3399.00
	P40	-3260K	3090.00
10 x 330	P50	-3265K	3039.00
	P60	-3270K	3039.00
	P80	-3275K	3039.00
10 x 457	P120	-3282K	4223.00
	P150	-3301K	4223.00
	P60	-4280K	4187.00
12 x 420	P120	-4300K	4187.00
	P240	-4340K	4187.00
	P40	-3302K	3348.00
	P60	-3304K	3348.00
13 x 305	P80	-3306K	3348.00
	P120	-3308K	3348.00
	P36	-3310K	4378.00
	P40	-3320K	4378.00
13 x 457	P60	-3330K	4378.00
	P80	-3342K	4378.00
	P120	-3382K	6179.00
	P36	-4360K	4378.00
13 x 610	P40	-4370K	4250.00
	P50	-4380K	4250.00
	P60	-4420K	4378.00
	P80	-4440K	4378.00
	P100	-4460K	4378.00
	P120	-4480K	4378.00
19 x 457	P150	-4500K	4378.00
	P80	-3390K	6179.00
20 x 457	P60	-3422K	8239.00
	P80	-3442K	6695.00
20 x 480	P120	-3450K	6695.00
	P40	-4660K	4554.00
	P50	-4670K	4554.00
	P60	-4680K	4691.00
20 x 520	P36	-4860K	4691.00
	P40	-4870K	4554.00
	P60	-4920K	4691.00
	P80	-4940K	4691.00
	P100	-4960K	4691.00
	P120	-4980K	4691.00
25 x 760	P150	-5000K	4691.00
	P240	-5040K	5942.00
	P36	-5100K	5665.00
	P60	-5130K	5665.00
25 x 1370	P80	-5140K	5665.00
	P120	-5160K	5665.00
	P100	-5320K	10815.00
	P50	-5420K	11588.00
50 x 287	P60	-5820K	9785.00
	P60	-5920K	19055.00
50 x 1525	P40	-6010K	22145.00
	P100	-6040K	22145.00
50 x 2000	P50	-6150K	23690.00
	P100	-7180K	25750.00
75 x 2000	P60	-7260K	27810.00
	P60	-7320K	14678.00
100 x 289	P80	-7330K	14678.00
	P120	-7350K	14678.00



Sanding Bands

Spiral wound with tear-resistant backing fabric. For grinding and finishing edges, profiles, welded joints etc. For use with power tools. Aluminium Oxide for use on most metals.



* P60 = Coarse, P80 = Medium, P150 = Fine.

Diameter x Width (mm)	Grit*	Weight per 50	Order Code YRK-205	Price/50 TB
10 x 10	P60	20g	-0520K	815.00
	P80	30g	-0550K	815.00
	P150	40g	-0580K	815.00
10 x 20	P60	50g	-0720K	961.00
	P80	50g	-0750K	961.00
	P150	40g	-0780K	961.00
13 x 10	P60	50g	-0920K	776.00
	P80	30g	-0950K	776.00
	P150	30g	-0980K	776.00
13 x 25	P60	90g	-1120K	1027.00
	P80	80g	-1150K	1027.00
	P150	60g	-1180K	1027.00
15 x 10	P60	40g	-1320K	776.00
	P80	40g	-1350K	776.00
	P150	30g	-1380K	776.00
15 x 30	P60	120g	-1520K	961.00
	P80	100g	-1550K	961.00
	P150	80g	-1580K	961.00
19 x 25	P60	140g	-1720K	961.00
	P80	110g	-1750K	961.00
	P150	80g	-1780K	961.00
22 x 20	P60	120g	-1920K	1064.00
	P80	110g	-1950K	1064.00
	P150	80g	-1980K	1064.00
25 x 25	P60	160g	-2120K	1145.00
	P80	150g	-2150K	1145.00
	P150	130g	-2180K	1145.00
30 x 20	P60	160g	-2320K	1158.00
	P80	130g	-2350K	1158.00
	P150	120g	-2380K	1158.00
30 x 30	P60	240g	-2520K	1250.00
	P80	200g	-2550K	1250.00
	P150	180g	-2580K	1250.00
38 x 25	P60	270g	-2720K	1346.00
	P80	220g	-2750K	1346.00
	P150	210g	-2780K	1346.00
45 x 30	P60	380g	-2920K	1634.00
	P80	310g	-2950K	1634.00
	P150	290g	-2980K	1634.00
51 x 25	P60	330g	-3120K	1634.00
	P80	300g	-3150K	1634.00
	P150	320g	-3180K	1634.00
60 x 30	P60	430g	-3320K	1999.00
	P80	400g	-3350K	1999.00
	P150	360g	-3380K	1999.00
75 x 30	P60	670g	-3520K	2496.00
	P80	490g	-3550K	2496.00
	P150	550g	-3580K	2496.00
100 x 40	P60	1100g	-3720K	3534.00
	P80	400g	-3750K	3534.00
	P150	700g	-3780K	3534.00

SANDING BANDS

Sanding Band Kits

Spiral wound with tear-resistant backing fabric. For grinding and finishing edges, profiles, welded joints etc. For use with power tools. Aluminium oxide for use on most metals.

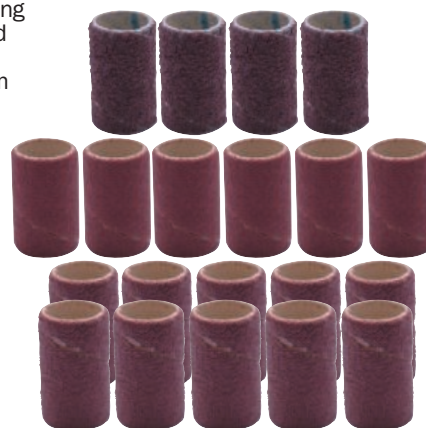

EXTENDED RANGE

Number of Pieces	Size (mm)	Contents	Order Code YRK-205	Price/1 TB
21	15 x 30	10 x P60 6 x P80 4 x P150 1 x 6mm Shank Holder	-9360K	773.00
21	22 x 20	10 x P60 6 x P80 4 x P150 1 x 6mm Shank Holder	-9300K	929.00
21	25 x 25	10 x P60 6 x P80 4 x P150 1 x 6mm Shank Holder	-9320K	807.00
21	51 x 25	10 x P60 6 x P80 4 x P150 1 x 6mm Shank Holder	-9340K	854.00

Drum Holders

Suitable for use with chucks/collets on all portable power and air tools. For use with spiral bound abrasive sanding bands. Self expanding when in use for a secure grip on the band. All shanks are 6mm, except where marked * which have an 8mm shank.



Diameter x Width (mm)	Min. RPM	Max. RPM	Weight per 5	Order Code YRK-205	Price/1 TB
10 x 10	33,250	47,500	50g	-4100K	335.00
10 x 20	33,250	47,500	70g	-4130K	439.00
13 x 10	25,500	36,500	60g	-4160K	439.00
13 x 25	25,500	36,500	80g	-4190K	439.00
15 x 10	22,000	31,500	70g	-4220K	439.00
15 x 30	22,000	31,500	100g	-4250K	439.00
19 x 25	17,500	25,000	110g	-4280K	470.00
22 x 20	14,700	21,000	120g	-4310K	470.00
25 x 25	13,000	19,000	140g	-4340K	470.00
30 x 20	11,000	15,800	150g	-4370K	470.00
30 x 30	11,000	15,800	200g	-4400K	470.00
38 x 25	8,700	12,500	240g	-4430K	470.00
45 x 30	9,000	10,500	380g	-4460K	514.00
51 x 25	7,400	9,300	360g	-4490K	628.00
60 x 30	6,500	7,900	460g	-4520K	628.00
75 x 30*	4,500	6,300	1100g	-4550K	909.00
100 x 40*	3,300	5,700	2100g	-4580K	2033.00

Fitting/Removal of Bands

Spindle Rotation During Use
(Holder expands)

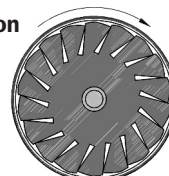

Band Rotation
(Holder stationary)

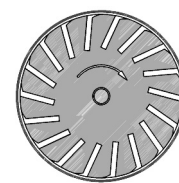

Max Operating Speeds (Peripheral = 25m/sec)

Band Dia. (mm)	Max (rpm)	Band Dia. (mm)	Max (rpm)
10	47,500	30	15,800
13	36,500	38	12,500
15	31,500	45	10,500
19	25,000	51	9,300
22	21,500	60	7,900
25	19,000	75	6,300
		100	4,700

GROUP 205 CARTRIDGE ROLLS



Cartridge Rolls



Spirally wound aluminium oxide cloth rolls that wear in use constantly exposing new abrasive. Used for weld flash removal, deburring, blending and polishing applications. Available in two types.

A steel mandrel must be used to secure the abrasive to the tool.

Maximum Running Speeds:

- Up to 12mm dia. 22,000rpm.
- Up to 19mm dia. 18,000rpm.
- Up to 25mm dia. 10,000rpm.

Straight Type

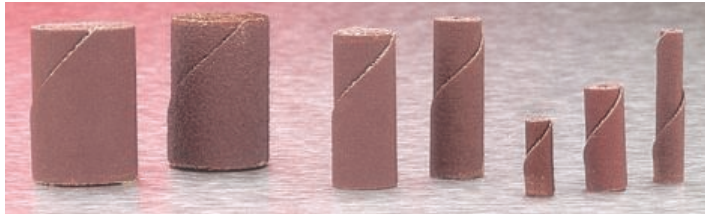

Diameter x Length (mm)	Type	Grit	Weight per 100	Order Code YRK-205	Price/1 TB
3 x 19	CR1	P80 P120	100g	-7010K -7020K	28.00 28.00
6 x 19	CR3	P80	150g	-7050K	28.00
6 x 25	CR4	P80 P120	200g	-7070K -7080K	28.00 28.00
6 x 38	CR4	P80 P120	200g	-7250K -7260K	31.00 48.00
9.5 x 25	CR5	P80	265g	-7090K	23.00
9.5 x 38	CR6	P80 P120	400g	-7110K -7120K	28.00 33.00
12 x 38	CR8	P60	670g	-7150K	33.00
		P80		-7155K	45.00
		P120		-7160K	45.00
19 x 38	CR10	P60	1500g	-7190K	57.00
		P120		-7200K	53.00

Mandrels

For use with Cartridge Rolls. This steel adaptor is used to secure and hold both tapered and parallel sided cartridge rolls to air grinders or electric drills. This holder is used by sliding the cartridge roll onto the mandrel pilot until the bottom of the abrasive touches the threaded steel area. Simply screw the cartridge roll onto the threads to secure. Your mandrel should be at least 13mm longer than your cartridge roll.



Shank Diameter	Type	To suit Rolls	Weight per 5	Order Code YRK-205	Price/1 TB
3mm	CRM1	CR1	35g	-7510K	246.00
3mm	CRM2	CR2	35g	-7520K	246.00
6mm	CRM3	CR3	55g	-7530K	285.00
6mm	CRM4	CR4	55g	-7540K	285.00
		CR5			
		CR7			
		CRT1			
		CRT2			
6mm	CRM5	CRT4	55g	-7550K	285.00
		CR6			
		CR8			
		CRT3			
6mm	CRM6	CR9	75g	-7560K	285.00
6mm	CRM7	CR10	80g	-7570K	285.00
		CR11			



Taper Type

Tapered for angles, corners and irregular or concave surfaces.

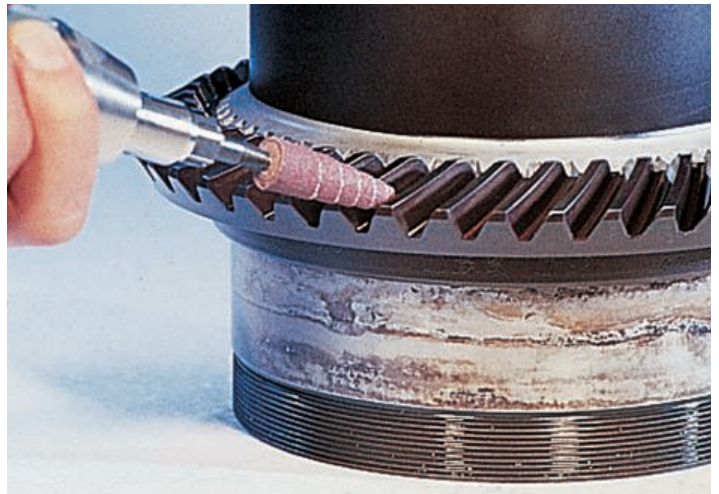
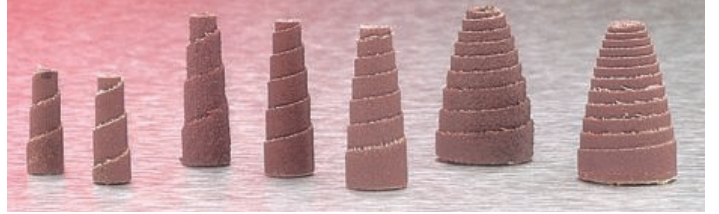

Diameter x Length (mm)	Type	Grit	Weight per 100	Order Code YRK-205	Price/1 TB
9.5 x 25	CRT1	P60	235g	-7310K	48.00
		P120		-7320K	48.00
9.5 x 38	CRT2	P80	256g	-7315K	48.00
12 x 25		P60	270g	-7330K	54.00
12 x 38	CRT3	P60	460g	-7350K	54.00
		P80		-7355K	56.00
		P120		-7360K	56.00

Cartridge Roll Kit

Spirally wound aluminium oxide cloth roll that wears in use, constantly exposing new abrasive. Used for weld flash removal, deburring, blending and polishing applications.

Contents:

Straight type rolls: 6 - 10 x 38mm P80 and P120, 4 - 13 x 38mm P80 and P120, 12 - 6 x 38mm P80 and P120, 16 - 6 x 25mm P80 and P125, 6 - 10 x 25mm P80 and P120.

Taper type rolls: 6 - 10 x 38mm P80. 6 - 13 x 38mm P80.

Mandrels:

- 1 - 3 x 25 x 6mm.
- 1 - 3 x 19 x 6mm.

**122
PIECES**



Description	Order Code YRK-205	Price/1 TB
122 Piece Cartridge Roll Kit	-9800K	3219.00



YORK ABRASIVES **Surface Preparation**

Quick Change Screw Fitting Discs

For general use including blending welds and removing machining marks. Also suitable for use on mild contours as well as flat surfaces. Quick change screw fitting ensures that the disc is always perfectly centred without adhesive, moving parts or centre screw damage to the workpiece. Higher speeds can be attained resulting in faster stock removal reduced man-hours and increased productivity. Available in two abrasive types, aluminium oxide for general-purpose use and zirconia alumina for grinding and finishing of stainless steel. Available in 25mm, 38mm, 50mm, 75mm and 100mm diameters for the abrasive discs. Also available in a surface preparation material that is designed for smoothing surfaces prior to painting, removing rust, oxides, imperfections and blending out grit disc marks to produce fine finishes on metal. All discs are compatible with 3M ROLOC™ system holders.

Disc Dia.	Grit	Weight per 100	Order Code YRK-205	Price/100 TB
25mm	P36	220g	-5010K	2632.00
	P40	220g	-5020K	2632.00
	P50	220g	-5030K	2632.00
	P60	220g	-5040K	2632.00
	P80	220g	-5050K	2632.00
	P100	220g	-5060K	2632.00
	P120	220g	-5070K	2632.00
38mm	P180	220g	-5080K	2632.00
	P36	320g	-5110K	2678.00
	P40	320g	-5120K	2678.00
	P50	320g	-5130K	2678.00
	P60	320g	-5140K	2678.00
	P80	320g	-5150K	2678.00
	P100	320g	-5160K	2678.00
50mm	P180	320g	-5180K	2678.00
	P36	620g	-5210K	3753.00
	P40	620g	-5220K	4691.00
	P50	620g	-5230K	4691.00
	P60	620g	-5240K	4691.00
	P80	620g	-5250K	4691.00
	P100	620g	-5260K	4691.00
75mm	P120	620g	-5270K	4691.00
	P180	620g	-5280K	4691.00
	P36	1330g	-5310K	5628.00
	P40	1330g	-5320K	5628.00
	P50	1330g	-5330K	5628.00
	P60	1330g	-5340K	5628.00
	P80	1330g	-5350K	5628.00
75mm	P100	1330g	-5360K	5628.00
	P120	1330g	-5370K	5628.00
	P180	1330g	-5380K	5628.00



Quick Change Screw Fitting Disc Kits

Multi-purpose kit containing: one of each surface preparation disc fine, medium and coarse. Two of each abrasive disc grades P36, P60, P80 and P120. One 6mm diameter shank to fit the backing pad.

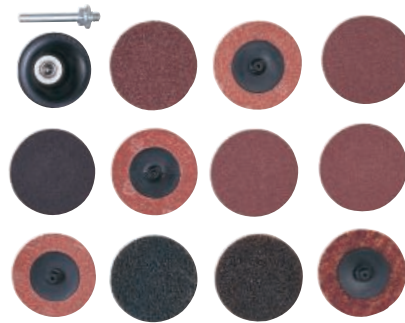

13 PIECES



Size	Weight each	Order Code YRK-205	Price/1 TB
50mm	250g	-9550K	1952.00
75mm	410g	-9600K	2076.00

Surface Preparation Discs

Designed for cleaning and finishing on all metals. Leaves a burr-free surface ready for painting or coating. Can also be used for the removal of light rust, oxides and coatings.



Surface Conditioning Kit

Aluminium oxide abrasive discs with quick change screw fitting. For cleaning and finishing on all metals leaving a burr-free surface ready for painting or coating. Can also be used for the removal of light rust, oxides and coatings. Suitable for use with power tools.

Size: 50mm diameter discs.

Contents:
2 discs x P36, P40, P50, P60, P80, P100, P120 and P180 grade.
Plus 6mm shank screw fitting disc holder.

Disc Dia.	Grit	Weight per 100	Order Code YRK-205	Price/100 TB
50mm	Fine	630g	-6210K	6254.00
	Med	630g	-6220K	6254.00
	Coarse	630g	-6230K	6254.00
75mm	Fine	1330g	-6310K	9714.00
	Med	1330g	-6320K	9714.00
	Coarse	1330g	-6330K	9714.00

17 PIECES

Size	Order Code YRK-205	Price/1 TB
50mm	-9500K	2890.00



Screw Fitting Disc Holders

Rubber holders to suit screw fitting discs. Supplied complete with 6mm diameter shank.

To Suit Disc Size	Weight Per 25	Order Code YRK-205	Price/1 TB
25mm	0.80kg	-6810K	634.00
38mm	0.95kg	-6820K	634.00
50mm	1.00kg	-6830K	652.00
75mm	2.00kg	-6840K	785.00

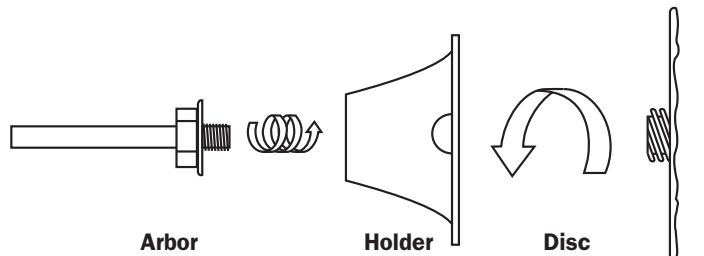

GROUP 210 CARBIDE BURRS

Carbide Burrs

Cut 3 - Rapid Cut

For use on softer non-ferrous and plastic materials, i.e. aluminium, fibreglass, plastics, hard rubber and zinc alloy.



Cut 6 - Double Cut

Crosscut and double cut to improve control and chipbreaks. Manufactured from high grade tungsten carbide for general-purpose use.



Cut 9 - Chipbreaker

Chipbreaker fast stock removal for improved control and reduced chips for use on hard materials, i.e. steel alloy 50RC, 60RC, carbon and cast iron.



Suitable for deburring and polishing of cast iron, cast steel, carbon steel, alloy steel and stainless steel etc. up to HRC65 hardness.

Please note:

- Workpiece and tools should always be steady and well supported.
- Carbide burrs are not suitable for 'milling' large amounts of material, they are for light stock removal at high rpm's 'LOW FEED - HIGH SPEED'.
- Always ensure that at least 70% of the shank length is clamped by the collet or chuck of the tool being used.
- Always ensure that the tool is rated to the recommended operating speed of the burr.

List Diameter	Recommended Operating Speeds (rpm)	Surface Speed
3	64,000 - 75,000	
6	32,000 - 38,000	
8	24,000 - 28,000	600 - 700
10	19,000 - 22,000	m/min
12	16,000 - 18,750	
16	12,000 - 14,000	

YORK ABRASIVES Carbide Burrs

Cylindrical-End Cutting

All sizes are nominal. Sizes marked * are 3mm shank, all others are 6mm shank.

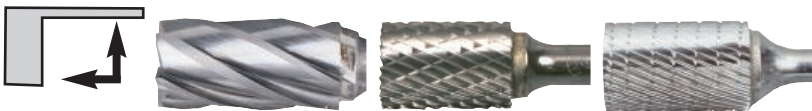

Head Size Ø x L (mm)	Cut 3 - Rapid Cut		Cut 6 - Double Cut		Cut 9 - Chipbreaker	
	Order Code YRK-210	Price/1 TB	Order Code YRK-210	Price/1 TB	Order Code YRK-210	Price/1 TB
3 x 12*	-	-	-	-	-0129K	418.00
3 x 14*	-	-	-0086K	337.00	-0089K	418.00
6 x 15*	-	-	-0126K	542.00	-	-
6 x 16	-	-	-0166K	716.00	-0169K	605.00
6 x 19	-0143K	716.00	-	-	-	-
8 x 19	-	-	-0206K	866.00	-0209K	661.00
10 x 19	-	-	-0246K	904.00	-0249K	778.00
13 x 25	-	-	-0286K	1152.00	-0289K	1059.00
16 x 25	-0383K	1931.00	-0406K	1806.00	-0409K	1558.00

Cylindrical Plain End

All sizes are nominal. Sizes marked * are 3mm shank, all others are 6mm shank.



Head Size Ø x L (mm)	Cut 3 - Rapid Cut		Cut 6 - Double Cut		Cut 9 - Chipbreaker	
	Order Code YRK-210	Price/1 TB	Order Code YRK-210	Price/1 TB	Order Code YRK-210	Price/1 TB
3 x 14*	-	-	-0586K	293.00	-0589K	530.00
4 x 13*	-	-	-	-	-0629K	616.00
6 x 13*	-	-	-0626K	405.00	-	-
6 x 16	-	-	-0666K	592.00	-0669K	741.00
6 x 19	-0643K	567.00	-	-	-	-
8 x 19	-	-	-0706K	680.00	-0709K	810.00
10 x 19	-0723K	1059.00	-0746K	741.00	-0749K	810.00
13 x 25	-	-	-0786K	997.00	-0789K	1029.00
16 x 25	-	-	-0906K	1495.00	-0909K	1495.00

Cylindrical Ball Nosed

All sizes are nominal. Sizes marked * are 3mm shank, all others are 6mm shank.



Head Size Ø x L (mm)	Cut 3 - Rapid Cut		Cut 6 - Double Cut		Cut 9 - Chipbreaker	
	Order Code YRK-210	Price/1 TB	Order Code YRK-210	Price/1 TB	Order Code YRK-210	Price/1 TB
3 x 14*	-	-	-1086K	368.00	-1089K	368.00
6 x 13*	-	-	-1126K	616.00	-1129K	616.00
6 x 16	-	-	-1166K	692.00	-1169K	692.00
8 x 19	-	-	-1206K	741.00	-1209K	741.00
10 x 19	-	-	-1246K	810.00	-1249K	810.00
11 x 25	-	-	-	-	-1329K	1115.00
13 x 25	-	-	-1326K	1115.00	-	-
16 x 25	-	-	-1406K	1558.00	-1409K	1558.00

KENNEDY Carbide Burrs

Cylindrical-End Cutting

All sizes are nominal. Sizes marked * are 3mm shank, all others are 6mm shank.

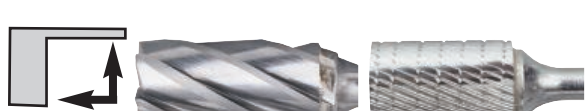

Head Size Ø x L (mm)	Cut 3 - Rapid Cut		Cut 9 - Chipbreaker	
	Order Code KEN-210	Price/1 TB	Order Code KEN-210	Price/1 TB
3 x 14*	-	-	-0080K	363.00
6 x 12*	-	-	-0120K	611.00
6 x 18	-0140K	736.00	-0160K	761.00
8 x 20	-	-	-0200K	741.00
10 x 20	-0220K	1619.00	-0240K	686.00
12 x 20	-	-	-0280K	1184.00
12 x 25	-0340K	2055.00	-0360K	1495.00
16 x 25	-	-	-0400K	1558.00

Cylindrical Plain End

All sizes are nominal. Sizes marked * are 3mm shank, all others are 6mm shank.



Head Size Ø x L (mm)	Cut 3 - Rapid Cut		Cut 9 - Chipbreaker	
	Order Code KEN-210	Price/1 TB	Order Code KEN-210	Price/1 TB
3 x 14*	-	-	-0580K	263.00
6 x 12*	-	-	-0620K	437.00
6 x 18	-	-	-0660K	487.00
8 x 20	-	-	-0700K	561.00
10 x 20	-0720K	741.00	-0740K	655.00
12 x 20	-	-	-0780K	872.00
12 x 25	-0840K	1558.00	-	-
16 x 25	-	-	-0900K	1214.00
19 x 25	-0980K	2614.00	-	-

Cylindrical Ball Nosed

All sizes are nominal. Sizes marked * are 3mm shank, all others are 6mm shank.

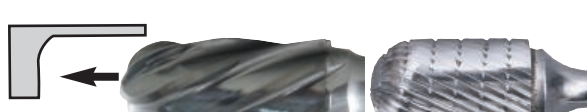

Head Size Ø x L (mm)	Cut 3 - Rapid Cut		Cut 9 - Chipbreaker	
	Order Code KEN-210	Price/1 TB	Order Code KEN-210	Price/1 TB
3 x 12*	-	-	-1080K	313.00
6 x 12*	-	-	-1120K	437.00
6 x 18	-1140K	778.00	-1160K	530.00
8 x 20	-	-	-1200K	686.00
10 x 20	-1220K	1059.00	-1240K	1059.00
12 x 25	-1300K	2205.00	-1320K	1059.00
16 x 25	-	-	-1400K	2055.00



Round Tree

All sizes are nominal. Sizes marked * are 3mm shank, all others are 6mm shank.

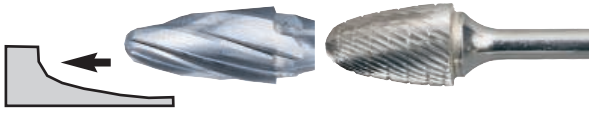

Head Size Ø x L (mm)	Cut 3 - Rapid Cut		Cut 9 - Chipbreaker	
	Order Code KEN-210	Price/1 TB	Order Code KEN-210	Price/1 TB
3 x 12	-	-	-3080K	313.00
6 x 18	-	-	-3160K	561.00
10 x 20	-3220K	1369.00	-3240K	741.00
12 x 25	-3300K	1868.00	-3320K	1868.00
16 x 25	-3380K	2739.00	-3400K	2179.00

Round Tree

All sizes are nominal. Sizes marked * are 3mm shank, all others are 6mm shank.



Head Size Ø x L (mm)	Cut 3 - Rapid Cut		Cut 6 - Double Cut		Cut 9 - Chipbreaker	
	Order Code YRK-210	Price/1 TB	Order Code YRK-210	Price/1 TB	Order Code YRK-210	Price/1 TB
3 x 13*	-	-	-3086K	368.00	-3089K	368.00
6 x 16	-	-	-3166K	810.00	-3169K	810.00
10 x 19	-	-	-3246K	890.00	-3249K	890.00
13 x 25	-	-	-3326K	1152.00	-3329K	1152.00
16 x 25	-	-	-	-	-3409K	1103.00

Flame Shape

All sizes are nominal. Sizes marked * are 3mm shank, all others are 6mm shank.



Head Size Ø x L (mm)	Cut 3 - Rapid Cut		Cut 9 - Chipbreaker	
	Order Code KEN-210	Price/1 TB	Order Code KEN-210	Price/1 TB
3 x 6*	-	-	-2120K	437.00
8 x 20	-	-	-2160K	636.00
12 x 32	-	-	-2320K	1558.00
16 x 35	-	-	-2400K	1931.00

Flame Shape

All sizes are nominal. Sizes marked * are 3mm shank, all others are 6mm shank.



Head Size Ø x L (mm)	Cut 3 - Rapid Cut		Cut 6 - Double Cut		Cut 9 - Chipbreaker	
	Order Code YRK-210	Price/1 TB	Order Code YRK-210	Price/1 TB	Order Code YRK-210	Price/1 TB
3 x 6*	-	-	-2126K	368.00	-2129K	368.00
8 x 19	-	-	-2166K	766.00	-2169K	766.00
13 x 32	-	-	-2326K	1432.00	-2329K	1432.00
16 x 36	-	-	-	-	-2409K	2163.00

Pointed Tree

All sizes are nominal. Sizes marked * are 3mm shank, all others are 6mm shank.



Head Size Ø x L (mm)	Cut 3 - Rapid Cut		Cut 9 - Chipbreaker	
	Order Code KEN-210	Price/1 TB	Order Code KEN-210	Price/1 TB
3 x 12*	-	-	-4120K	281.00
6 x 12*	-	-	-4160K	437.00
10 x 20	-	-	-4240K	748.00
12 x 20	-	-	-4280K	997.00
12 x 25	-	-	-4320K	1115.00
16 x 25	-	-	-4400K	1369.00

Pointed Tree

All sizes are nominal. Sizes marked * are 3mm shank, all others are 6mm shank.



Head Size Ø x L (mm)	Cut 3 - Rapid Cut		Cut 6 - Double Cut		Cut 9 - Chipbreaker	
	Order Code YRK-210	Price/1 TB	Order Code YRK-210	Price/1 TB	Order Code YRK-210	Price/1 TB
3 x 13*	-	-	-4126K	342.00	-4129K	342.00
6 x 13*	-	-	-4166K	630.00	-4169K	630.00
10 x 19	-	-	-4246K	810.00	-4249K	810.00
13 x 19	-	-	-	-	-4289K	1737.00
13 x 25	-	-	-4326K	1089.00	-4329K	778.00
16 x 25	-	-	-4406K	1495.00	-4409K	1495.00

Ball Shape

All sizes are nominal. Sizes marked * are 3mm shank, all others are 6mm shank.



Head Size Ø x L (mm)	Cut 3 - Rapid Cut		Cut 9 - Chipbreaker	
	Order Code KEN-210	Price/1 TB	Order Code KEN-210	Price/1 TB
3 x 3*	-	-	-6080K	313.00
4 x 4*	-	-	-6120K	686.00
6 x 6*	-	-	-6160K	530.00
8 x 8	-	-	-6200K	530.00
10 x 10	-6220K	810.00	-6240K	810.00
12 x 12	-	-	-6320K	829.00
16 x 15	-	-	-6360K	1028.00

Ball Shape

All sizes are nominal. Sizes marked * are 3mm shank, all others are 6mm shank.



Head Size Ø x L (mm)	Cut 3 - Rapid Cut		Cut 6 - Double Cut		Cut 9 - Chipbreaker	
	Order Code YRK-210	Price/1 TB	Order Code YRK-210	Price/1 TB	Order Code YRK-210	Price/1 TB
3 x 3*	-	-	-6086K	405.00	-6089K	405.00
5 x 4*	-	-	-6126K	1608.00	-6129K	1608.00
6 x 5	-	-	-6166K	729.00	-6169K	729.00
8 x 6	-	-	-6206K	605.00	-6209K	605.00
11 x 10	-	-	-6246K	1575.00	-6249K	1575.00
13 x 11	-	-	-6326K	1575.00	-6329K	1575.00
16 x 14	-	-	-	-	-6369K	1931.00

Oval Shape

All sizes are nominal. Sizes marked * are 3mm shank, all others are 6mm shank.



Head Size Ø x L (mm)	Cut 3 - Rapid Cut		Cut 9 - Chipbreaker	
	Order Code KEN-210	Price/1 TB	Order Code KEN-210	Price/1 TB
3 x 6*	-	-	-5120K	288.00
6 x 10*	-	-	-5160K	561.00
9.5 x 15	-	-	-5200K	810.00
12 x 20	-	-	-5240K	1184.00
16 x 25	-5300K	2428.00	-5320K	1082.00
19 x 25	-5360K	2318.00	-	-

Oval

All sizes are nominal. Sizes marked * are 3mm shank, all others are 6mm shank.

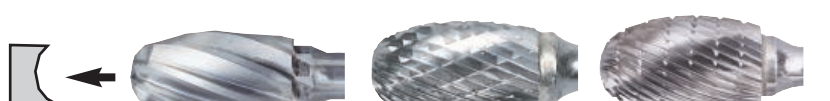

Head Size Ø x L (mm)	Cut 3 - Rapid Cut		Cut 6 - Double Cut		Cut 9 - Chipbreaker	
	Order Code YRK-210	Price/1 TB	Order Code YRK-210	Price/1 TB	Order Code YRK-210	Price/1 TB
3 x 6*	-	-	-5126K	381.00	-	-
6 x 10*	-	-	-5166K	616.00	-5169K	616.00
10 x 16	-	-	-5206K	778.00	-5209K	778.00
13 x 22	-	-	-5246K	1089.00	-5249K	1089.00
16 x 25	-	-	-	-	-5329K	1288.00

GROUP 210 CARBIDE BURRS



Carbide Burrs

Conical

All sizes are nominal. Sizes marked * are 3mm shank, all others are 6mm shank.

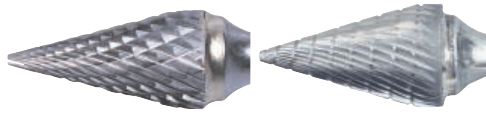
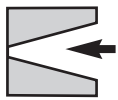

Head Size R x L (mm)	Cut 3 - Rapid Cut		Cut 6 - Double Cut		Cut 9 - Chipbreaker	
	Order Code YRK-210	Price/1 TB	Order Code YRK-210	Price/1 TB	Order Code YRK-210	Price/1 TB
3 x 11*	-	-	-7126K	268.00	-7129K	268.00
6 x 13*	-	-	-7166K	561.00	-7169K	561.00
6 x 19	-	-	-7206K	686.00	-7209K	686.00
10 x 16	-	-	-7246K	854.00	-7249K	854.00
13 x 22	-	-	-7326K	1059.00	-7329K	1059.00
16 x 25	-	-	-7406K	2110.00	-	-

Conical 14°

All sizes are nominal. Sizes marked * are 3mm shank, all others are 6mm shank.

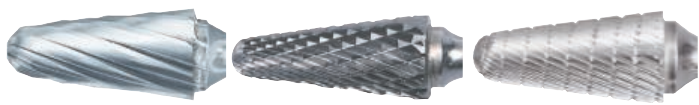
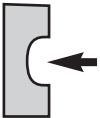

Head Size R x L (mm)	Cut 3 - Rapid Cut		Cut 6 - Double Cut		Cut 9 - Chipbreaker	
	Order Code YRK-210	Price/1 TB	Order Code YRK-210	Price/1 TB	Order Code YRK-210	Price/1 TB
3 x 13*	-	-	-8126K	431.00	-	-
5 x 13*	-	-	-	-	-8129K	318.00
6 x 12*	-	-	-8166K	655.00	-	-
6 x 16*	-	-	-	-	-8168K	903.00
6 x 16	-	-	-	-	-8169K	518.00
8 x 22	-	-	-8206K	890.00	-8209K	890.00
10 x 27	-	-	-8246K	1004.00	-8249K	1004.00
13 x 28	-	-	-8326K	1103.00	-8329K	1103.00
16 x 30	-	-	-8406K	1184.00	-8409K	1558.00

Conical 60° Inc. Angle



Head Size R x L (mm)	Cut 9 - Chipbreaker	
	Order Code YRK-210	Price/1 TB
10 x 8	-8649K	1059.00
16 x 14	-8669K	904.00

Conical 90° Inc. Angle



Head Size R x L (mm)	Conical 90° Inc. Angle	
	Order Code YRK-210	Price/1 TB
6 x 3	-8919K	797.00
10 x 5	-8939K	778.00
12.7 x 6.3	-8959K	1059.00

Inverted Cone.

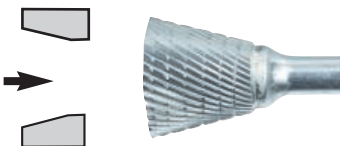

Head Size R x L (mm)	Inverted Cone	
	Order Code YRK-210	Price/1 TB
12.7 x 12.7	-9329K	935.00
19 x 16	-9489K	1382.00

All sizes are nominal. Sizes marked * are 3mm shank, all others are 6mm shank.

Carbide Burr Sets

Sets of various style burrs packaged in a handy pocket 'glasses case' style plastic holder. Ideal for the shop floor workman with various deburring tasks.

Operating speeds: 6,000 - 40,000rpm.

Cut 6 - 6mm Shank Contents 1x each:

- 10 x 19mm cylindrical end cutting, cylindrical plain end, cylindrical ball end, round tree, pointed tree,
- 6 x 5mm spherical,
- 6 x 19mm conical,
- 10 x 27 conical 14°.

Cut 6 - 3mm Shank Contents 1x each:

- 3 x 14mm cylindrical end cutting,
- 3 x 14mm cylindrical plain end,
- 3 x 14mm cylindrical ball end,
- 6 x 13mm pointed tree,
- 6 x 10mm oval,
- 3 x 3mm spherical,
- 3 x 11mm conical,
- 6 x 19mm conical 14°.

**8
PIECES**



Number of Pieces	Shank Size	Order Code YRK-210	Price/1 TB
8	3mm	-9896K	2986.00
8	6mm	-9886K	4654.00



Conical

All sizes are nominal. Sizes marked * are 3mm shank, all others are 6mm shank.



Head Size R x L (mm)	Cut 3 - Rapid Cut		Cut 9 - Chipbreaker	
	Order Code KEN-210	Price/1 TB	Order Code KEN-210	Price/1 TB
3 x 11*	-	-	-7120K	313.00
6 x 12*	-	-	-7160K	437.00
6 x 20	-	-	-7200K	561.00
10 x 20	-	-	-7240K	935.00
12 x 25	-	-	-7320K	1184.00
16 x 25	-	-	-7400K	1558.00

Conical 14°

All sizes are nominal. Sizes marked * are 3mm shank, all others are 6mm shank.

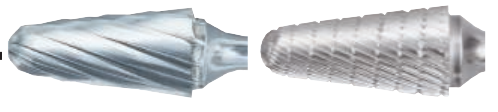
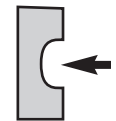

Head Size R x L (mm)	Cut 3 - Rapid Cut		Cut 9 - Chipbreaker	
	Order Code KEN-210	Price/1 TB	Order Code KEN-210	Price/1 TB
3 x 11*	-	-	-8120K	342.00
6 x 12*	-	-	-8160K	561.00
8 x 22	-	-	-8200K	686.00
10 x 26	-8220K	1868.00	-8240K	1681.00
12 x 28	-8300K	3112.00	-8320K	1558.00
16 x 33	-	-	-8400K	2614.00

Conical 60° Inc. Angle

All sizes are nominal. Sizes marked * are 3mm shank, all others are 6mm shank.



Head Size R x L (mm)	Cut 3 - Rapid Cut		Cut 9 - Chipbreaker	
	Order Code KEN-210	Price/1 TB	Order Code KEN-210	Price/1 TB
6 x 4	-	-	-8620K	810.00
10 x 8	-	-	-8640K	1059.00
16 x 14	-	-	-8660K	1558.00

Conical 90° Inc. Angle

All sizes are nominal. Sizes marked * are 3mm shank, all others are 6mm shank.

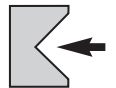

Head Size R x L (mm)	Cut 3 - Rapid Cut		Cut 9 - Chipbreaker	
	Order Code KEN-210	Price/1 TB	Order Code KEN-210	Price/1 TB
3 x 3	-	-	-8870K	372.00
6 x 3	-	-	-8910K	437.00
10 x 4	-	-	-8930K	686.00
12 x 6	-	-	-8950K	1395.00

Inverted Cone

All sizes are nominal. Sizes marked * are 3mm shank, all others are 6mm shank.



Head Size R x L (mm)	Cut 3 - Rapid Cut		Cut 9 - Chipbreaker	
	Order Code KEN-210	Price/1 TB	Order Code KEN-210	Price/1 TB
6 x 8	-	-	-9160K	810.00
13 x 12	-	-	-9320K	1495.00
19 x 16	-	-	-9480K	2241.00

**YORK
ABRASIVES****Diamond Coated
Burr Set**

DIAMOND



Set of various style burrs packaged in a handy pocket 'glasses case' style plastic holder. Ideal for the shop floor worker with various deburring tasks. Assorted sizes of ball shape, cylindrical, ball nose cylindrical, tree shape and conical. Up to 4.5mm diameter. 3m shank.

Overall length: 45mm.

**30
PIECES**

Number of Pieces	Order Code YRK-210	Price/1 TB
30	-9900K	2139.00

Diamond Coated Burrs

3mm shank. Overall length 45mm. Diamond grip mesh is 120/140. Recommended operating speeds 15,000 - 30,000rpm.

Suitable for precision grinding of carbide gems, ceramics, tough alloys, cermets, tool steels etc.

Cylindrical

Head Dia. x Length (mm)	Order Code YRK-210	Price/1 TB
1.0 x 9	-9010K	83.00
1.5 x 9	-9015K	87.00
2.0 x 10	-9020K	93.00
2.5 x 10	-9025K	87.00
3.0 x 10	-9030K	100.00
4.0 x 10	-9040K	100.00
5.0 x 10	-9050K	100.00

Cylindrical Ball Nosed

Head Dia. x Length (mm)	Order Code YRK-210	Price/1 TB
1.5 x 9	-9115K	87.00
2.0 x 10	-9120K	87.00
2.5 x 10	-9125K	100.00
3.0 x 10	-9130K	93.00
4.0 x 10	-9140K	100.00
5.0 x 10	-9150K	115.00

**YORK
ABRASIVES****'Speedway'
Burr Sets**

Unique flute design: fine pitch and coarse pitch flutes for rapid material removal, while maintaining a smooth surface finish.

Contains 1x each:

10 x 19mm cylindrical end cutting, cylindrical plain end, cylindrical ball end, round tree, pointed tree, 6 x 5mm spherical, 6 x 19mm conical, 10 x 27 conical 14°.

**8
PIECES****UNIQUE
'DUAL CUT'
DESIGN**

Number of Pieces	Shank Size	Order Code YRK-210	Price/1 TB
8	3mm	-9940K	2382.00
8	6mm	-9920K	5249.00

**KENNEDY
QUALITY INDUSTRIAL TOOLING Carbide
Burr Set****Cut 9**

Chipbreaker fast stock removal for improved control and reduced chips for use on hard materials, i.e. steel alloy 50RC, 60RC, carbon and cast iron.

Operating speeds:

6,000 - 40,000rpm.
6mm shank.

Contents 1 each:

10 x 20 & 12 x 25mm Ball nose.
12 x 25mm Plain cylindrical.
12 x 25 & 10 x 20mm Round tree.
12 x 12mm Ball.
9.5 x 15mm Oval.
10 x 20mm Pointed tree.

**8
PIECES**

Number of Pieces	Order Code KEN-210	Price/1 TB
8	-9880K	6535.00

DIAMOND BURRS GROUP 210**Ball Nosed**

Head Dia. x Length (mm)	Order Code YRK-210	Price/1 TB
1.0 x 1.0	-9310K	83.00
2.0 x 2.0	-9320K	83.00
3.0 x 3.0	-9330K	83.00
4.0 x 4.0	-9340K	95.00
5.0 x 5.0	-9350K	95.00

Round Tree

Head Dia. x Length (mm)	Order Code YRK-210	Price/1 TB
2.0 x 10	-9510K	87.00
3.0 x 10	-9570K	100.00
3.3 x 10	-9610K	100.00
3.3 x 10	-9620K	100.00

Pointed Tree

Head Dia. x Length (mm)	Order Code YRK-210	Price/1 TB
2.0 x 9	-9220K	87.00
3.0 x 9	-9230K	100.00
4.0 x 10	-9240K	100.00
5.0 x 10	-9250K	100.00

Conical

Included Angle	Head Dia. x Length	Order Code YRK-210	Price/1 TB
7°	2 x 12	-9770K	87.00
10°	3 x 15	-9800K	115.00

**SENATOR
QUALITY TOOLING****Diamond Coated
Burr Set**

10 piece assortment of burrs, all diamond coated, in a fitted wooden box.

**Contents (with 3mm shank) 1x each:**

cylindrical 2 x 8mm, 3 x 10mm and 5 x 10mm, cylindrical ball nosed 5 x 10mm, pointed tree 2 x 10mm and 3 x 10mm, ball 2mm, 3mm and 5mm, 10° conical 0.5/3mm x 15mm.

NEW**10
PIECES**

Number of Pieces	Order Code SEN-210	Price/1 TB
10	-8980K	550.00

Diamond Coated Burr Set

Set of various style burrs packaged in a fitted plastic case. Assorted sizes of ball shape, cylindrical, ball nose cylindrical, tree shape and conical. Up to 4.5mm diameter. 3mm shank.

Overall length: 45mm.

DIAMOND

**30
PIECES**

Number of Pieces	Order Code SEN-210	Price/1 TB
30	-9000K	1059.00

PRODUCTS ARE ONLY AVAILABLE VIA YOUR DISTRIBUTOR

© 2016

YORK ABRASIVES Flap Discs

High performance alternative to sanding discs. Have the advantage over depressed centre grinding discs on light gauge sheet metal where surface finish is important. Overlapped abrasive strips slowly wear away revealing fresh abrasive, ensuring the disc always cuts effectively, reducing clogging and providing constant finish throughout disc life. No backing pads needed. Safe to use at 80m/s on any grinder. Tested at 150m/s and approved by the German Grinding Wheel Authority (DSA). Available in two grades and with two types of backing.

Precision Layered



115mm Rust & Paint Removal Disc

Made of intertwined nylon fibres which are then immersed in synthetic resin and gently hardened. Ideal for removing old paint, rust and welding splatter without scratching the surface of the workpiece, cleaning and smoothing wood and plastic, polishing of stainless steel and removal of thermal bluing. **DIN EN 13743.**



Size x Bore (mm)	Maximum rpm	Order Code YRK-245	Price/1 TB
115 x 22	10,500	-3800K	468.00

Non-woven Polishing Flap Discs

High performance non-woven flap discs make an ideal choice for polishing and finishing stainless steel, carbon steel, non-ferrous metals etc. Available in two sizes and choice of coarse, medium and fine. Maximum rpm 13,280 and maximum speed 80m/s.

NEW



Size (mm)	Grade	Order Code YRK-220	Price/1 TB
115 x 22	Coarse	-9800K	335.00
115 x 22	Medium	-9810K	335.00
115 x 22	Fine	-9820K	335.00
125 x 22	Coarse	-9830K	387.00
125 x 22	Medium	-9840K	387.00
125 x 22	Fine	-9850K	387.00

Aluminium Oxide Grade Aluminium-Backed (General-purpose).



Grit	Weight per 10	Order Code YRK-220	Price/1 TB
100mm Dia x 16mm Bore 15,300 MOS (rpm)			
P36	0.90kg	-9010K	199.00
P40	0.85kg	-9020K	199.00
P60	0.75kg	-9030K	199.00
P80	0.70kg	-9040K	199.00
P120	0.65kg	-9050K	199.00
115mm Dia x 22mm Bore 13,300 MOS (rpm)			
P36	1.10kg	-9110K	205.00
P40	1.20kg	-9120K	205.00
P60	1.20kg	-9130K	205.00
P80	1.05kg	-9140K	205.00
P120	0.90kg	-9150K	205.00
127mm Dia x 22mm Bore 12,000 MOS (rpm)			
P36	1.40kg	-9210K	270.00
P40	1.60kg	-9220K	270.00
P60	1.40kg	-9230K	270.00
P80	1.40kg	-9240K	270.00
P120	1.40kg	-9250K	270.00
180mm Dia x 22mm Bore 8,600 MOS (rpm)			
P40	3.20kg	-9320K	567.00

Zirconium Grade Aluminium-Backed (For stainless steel).



Grit	Weight per 10	Order Code YRK-220	Price/1 TB
100mm Dia x 16mm Bore 15,300 MOS (rpm)			
P36	0.85kg	-8010K	191.00
P40	0.80kg	-8020K	191.00
P60	0.80kg	-8030K	196.00
P80	0.70kg	-8040K	196.00
P120	0.70kg	-8050K	196.00
115mm Dia x 22mm Bore 13,300 MOS (rpm)			
P36	1.20kg	-8110K	229.00
P40	1.25kg	-8120K	220.00
P60	1.20kg	-8130K	220.00
P80	1.00kg	-8140K	220.00
P120	8.00kg	-8150K	220.00
127mm Dia x 22mm Bore 12,000 MOS (rpm)			
P40	1.55kg	-8220K	270.00
P60	1.50kg	-8230K	270.00
P80	1.10kg	-8240K	270.00
P120	1.30kg	-8250K	270.00

Aluminium Oxide Grade Glass Fibre-Backed (General-purpose, non-scratch).



Grit	Weight per 10	Order Code YRK-220	Price/1 TB
100mm Dia x 16mm Bore 15,300 MOS (rpm)			
P36	0.70kg	-9410K	176.00
P40	0.70kg	-9420K	176.00
P60	0.65kg	-9430K	176.00
P80	0.60kg	-9440K	176.00
P120	0.55kg	-9450K	176.00
115mm Dia x 22mm Bore 13,300 MOS (rpm)			
P36	0.95kg	-9510K	205.00
P40	0.90kg	-9520K	205.00
P60	0.85kg	-9530K	205.00
P80	0.75kg	-9540K	205.00
P120	0.75kg	-9550K	205.00
127mm Dia x 22mm Bore 12,000 MOS (rpm)			
P36	1.30kg	-9610K	234.00
P40	1.20kg	-9620K	234.00
P60	1.10kg	-9630K	234.00
P80	1.00kg	-9640K	234.00
P120	0.90kg	-9650K	234.00
180mm Dia x 22mm Bore 8,600 MOS (rpm)			
P36	2.40kg	-9710K	365.00
P40	2.30kg	-9720K	356.00

Zirconium Grade Glass Fibre-Backed (For stainless steel, non-scratch).



Grit	Weight per 10	Order Code YRK-220	Price/1 TB
100mm Dia x 16mm Bore 15,300 MOS (rpm)			
P36	0.70kg	-8410K	175.00
P40	0.70kg	-8420K	175.00
P60	0.70kg	-8430K	175.00
P80	0.60kg	-8440K	175.00
P120	0.55kg	-8450K	175.00
115mm Dia x 22mm Bore 13,300 MOS (rpm)			
P36	0.85kg	-8510K	199.00
P40	0.80kg	-8520K	199.00
P60	0.90kg	-8530K	199.00
P80	0.80kg	-8540K	199.00
P120	0.75kg	-8550K	199.00
127mm Dia x 22mm Bore 12,000 MOS (rpm)			
P36	1.20kg	-8610K	234.00
P40	1.15kg	-8620K	234.00
P60	1.15kg	-8630K	234.00
P120	1.00kg	-8650K	234.00
180mm Dia x 22mm Bore 8,600 MOS (rpm)			
P36	2.60kg	-8710K	361.00
P40	2.30kg	-8720K	361.00
P60	2.20kg	-8730K	361.00
P80	2.00kg	-8740K	361.00

Polishing & Finishing Kits

Multi-pack
High performance five piece surface finishing and polishing kits.

Kit Contents:
2x 110g polishing bars
1x Flap disc (Fine)
1x Flap disc (Coarse)
1x Polishing wheel

Size	Order Code YRK-220	Price/1 TB
115mm	-9905K	1700.00
125mm	-9910K	1803.00



GROUP 230 CUTTING & GRINDING DISCS



Depressed Centre Cutting & Grinding Discs

- For general-purpose use on metals.
 - For use on stone and non-ferrous materials.
 - For use on stainless steel.
- Grade X24** - Special, for use on cast iron.

Type 27 Depressed Centre Grinding

Manufactured to assure operator safety and optimum performance. For use with all portable angle grinders. Not to be used for 'free hand' or wet grinding.

Optimum angle for use 25 to 35°.

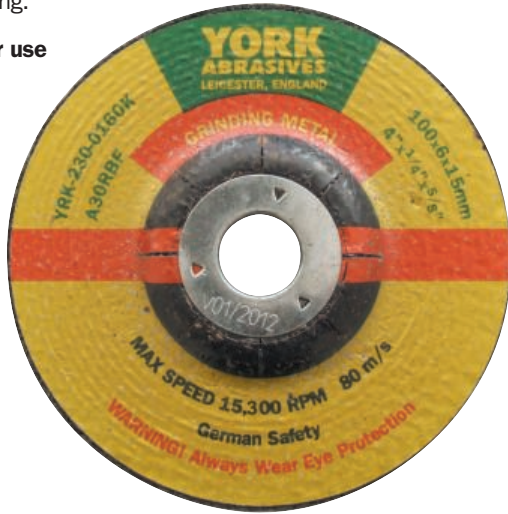

Size (mm)	Box Quantity	Grade	Weight Per 50	Order Code YRK-230	Price/1 TB
100 x 5 x 16	25	A30RBF	4.20kg	-0120K	67.00
100 x 6 x 16	25	A30RBF	6.20kg	-0160K	74.00
115 x 5 x 22	25	A30RBF	5.80kg	-1120K	85.00
115 x 6 x 22	25	A30RBF	8.00kg	-1160K	85.00
125 x 6 x 22	25	A30RBF	9.40kg	-2160K	102.00
180 x 5 x 22	10	A30RBF	14.2kg	-3120K	151.00
180 x 6 x 22	10	A30RBF	18.4kg	-3160K	157.00
180 x 6 x 22	10	R30RBF	18.4kg	-3660K	168.00
230 x 6 x 22	10	A30RBF	28.8kg	-4160K	223.00
230 x 6 x 22	10	X24RBF	26.0kg	-4180K	223.00

Type 42 Depressed Centre Cutting

Manufactured to assure operator safety and optimum performance. For use with all portable grinders/cut-off machines. Not to be used for 'free hand' cutting and importantly not to be used for grinding.



Size	Grade	Weight Per 50	Order Code YRK-230	Price/1 TB
100 x 3 x 16	A30TBF	3.30kg	-0080K	42.00
115 x 3 x 22	A30TBF	3.90kg	-1080K	74.00
125 x 3 x 22	A30RBF	4.30kg	-2080K	85.00
180 x 3 x 22	A30TBF	10.6kg	-3080K	116.00
230 x 3 x 22	A30RBF	15.0kg	-4080K	175.00

Flat Reinforced Cutting Discs

- Grade A30** - For general-purpose use on metals.
- Grade C24** - For use on stone and non-ferrous materials.
- Grade R30** - For use on stainless steel.
- Grade X24** - Special, for use on cast iron.

Type 41 Flat Reinforced Cutting

Manufactured to assure operator safety and optimum performance. For use with all portable angle grinders. 180mm to 230mm discs can also be used on circular saws and 300 to 350mm discs are for use with chop saws/cut-off machines, subject to bore compatibility. Not to be used for wet cutting.

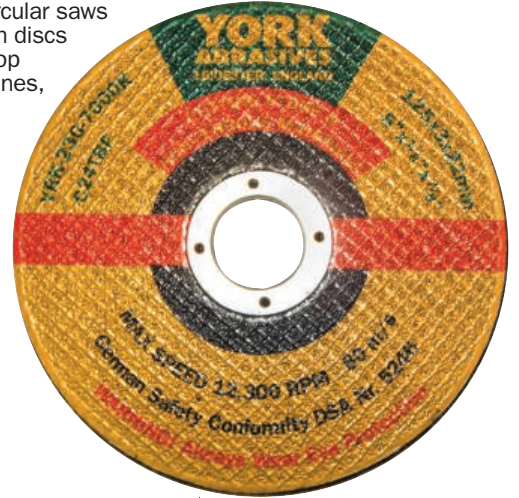

Size (mm)	Grade	Weight Per 50	Order Code YRK-230	Price/1 TB
100 x 3 x 16	A30RBF	2.60kg	-5080K	67.00
100 x 3 x 16	C24RBF	2.60kg	-5800K	67.00
115 x 3 x 22	A30TBF	4.00kg	-6080K	67.00
115 x 3 x 22	C24RBF	3.50kg	-6800K	67.00
125 x 3 x 22	A30RBF	4.20kg	-6950K	74.00
125 x 3 x 22	C24TBF	4.30kg	-7000K	74.00
180 x 3 x 22	A30TBF	9.20kg	-7080K	91.00
180 x 3 x 22	C24TBF	8.50kg	-7800K	91.00
230 x 3 x 22	A30TBF	15.0kg	-8080K	151.00
230 x 3 x 22	C24TBF	14.6kg	-8800K	151.00
300 x 3 x 20	A30RBF	18.8kg	-9080K	191.00
300 x 3 x 20	C24RBF	25.0kg	-9090K	191.00
300 x 3 x 22	A30RBF	28.8kg	-9800K	191.00
300 x 3 x 22	C24RBF	25.0kg	-9810K	191.00
355 x 3 x 25	A24NBF	34.6kg	-9920K	354.00

Cutting Discs - Inox

Type 41 - Flat Reinforced Cutting

Flat reinforced cutting discs for use with portable angle grinders. 180mm and 230mm discs can also be used on circular saws. Not to be used for wet cutting. For stainless steel (iron, chlorine and sulphur-free). EN 12413.

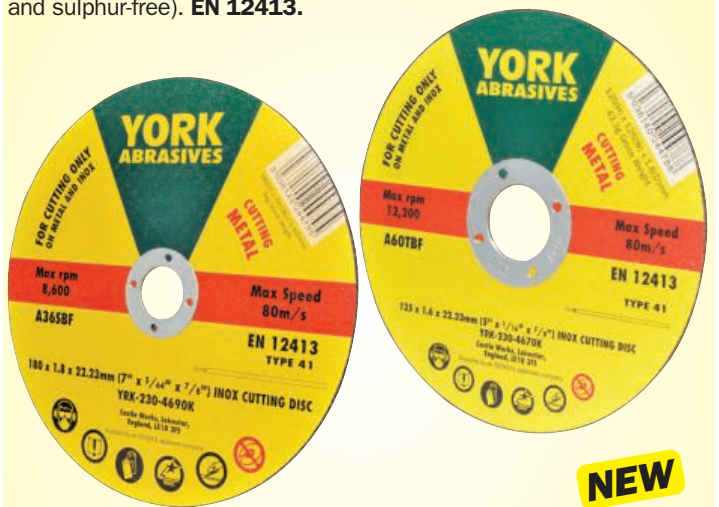

Size (mm)	Grade	Max Speed (rpm)	Order Code YRK-230	Price/1 TB
100 x 1.0 x 16.00		15,200	-4610K	21.00
115 x 1.0 x 22.23	A60-TBF Inox	13,300	-4630K	31.00
115 x 1.6 x 22.23		13,300	-4640K	31.00
125 x 1.0 x 22.23			-4660K	37.00
125 x 1.6 x 22.23	A60-TBF Inox	12,200	-4670K	37.00
180 x 1.8 x 22.23		8,600	-4690K	78.00
230 x 1.8 x 22.23	A36-SBF Inox	6,600	-4710K	98.00



NEW



Depressed Centre & Flat Reinforced Cutting & Grinding Discs

All Kennedy Depressed Centre and Flat Reinforced Cutting Wheels now carry the 'oSa' (The Organisation for the Safety of Abrasives) mark of approval. 'oSa' is an association of the world's leading abrasives manufacturers. In France, it is mandatory to use only oSa-certified rough grinding wheels and cutting wheels. Similarly in Germany and Italy, it is strongly recommended that abrasive products conform to the relevant EN standards. 'oSa' marked products are guaranteed to meet or exceed the highest worldwide safety standards, including those of the Comite Europeen de Normalisation (CEN), the European standards body that issues EN standards, and of ANSI in the USA.



Type 27 Depressed Centre Grinding

For use with all portable angle grinders.
Not to be used for 'free hand' or wet grinding.
Optimum angle for use 25 to 35°.

Grade A30/AS30 - For general-purpose use on metals.
INOX - For use on stainless steel (iron, chlorine and sulphur free).

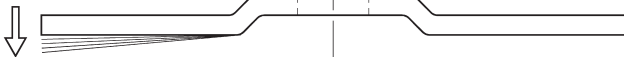

Size (mm)	Grade	Weight Per 50	Order Code KEN-230	Price/1 TB
50 x 4 x 9.6	A80-QBF	1.02kg	-0050K	155.00
50 x 4 x 9.6	A120-QBF	0.90kg	-0060K	155.00
100 x 6 x 16	A30-TBF	6.20kg	-0160K	85.00
115 x 4 x 22.23	AS30-RBF	5.80kg	-1120K	67.00
115 x 6 x 22.23	A30-TBF	8.00kg	-1160K	80.00
125 x 6 x 22.23	A30-TBF	9.40kg	-2160K	91.00
180 x 6 x 22.23	A30-TBF	18.4kg	-3160K	140.00
230 x 6 x 22.23	A30-TBF	28.8kg	-4160K	266.00
230 x 6 x 22.23	AS30-INOX-BF	26.0kg	-4200K	300.00

Type 42 Depressed Centre Cutting

For use with all portable grinders/cut-off machines.
Not to be used for 'free hand' cutting and importantly not to be used for grinding.

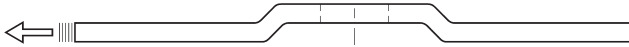

Grade A24/A46 - For general purpose cutting on metals.

Size (mm)	Grade	Weight Per 50	Order Code KEN-230	Price/1 TB
100 x 3 x 16	A24RBF	3.30kg	-0080K	67.00
115 x 3 x 22.23	A24RBF	3.90kg	-1080K	55.00
125 x 3 x 22.23	A24RBF	4.30kg	-2080K	67.00
180 x 3 x 22.23	A24RBF	10.6kg	-3080K	132.00
230 x 3 x 22.23	A24RBF	15.0kg	-4080K	155.00

Type 41 Flat Reinforced Cutting

For use with all portable angle grinders. 180mm to 230mm discs can also be used on circular saws, and 300 to 350mm discs are for use with chop saws/cut-off machines, subject to bore compatibility. Not to be used for wet cutting.

Grade A24/A36 - For general-purpose cutting on metals.
Grade C24 - For general-purpose cutting on stone.

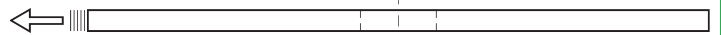
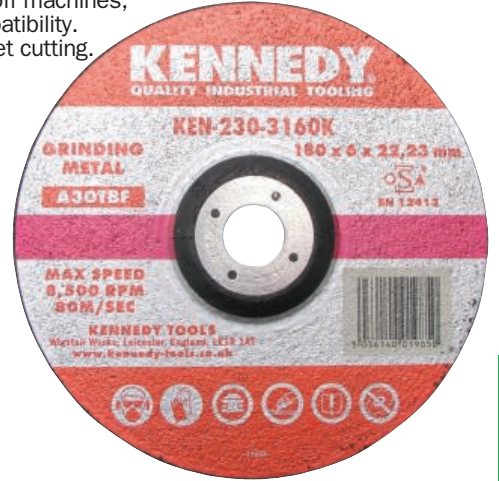

Size (mm)	Grade	Weight Per 50	Order Code KEN-230	Price/1 TB
100 x 3 x 16	A24-RBF	2.60kg	-5080K	67.00
100 x 3 x 16	C24-RBF	2.60kg	-5800K	67.00
115 x 3 x 22.23	A24-RBF	4.00kg	-6080K	80.00
115 x 3 x 22.23	C24-RBF	3.50kg	-6800K	80.00
125 x 3 x 22.23	A24-RBF	4.20kg	-6950K	102.00
180 x 3 x 22.23	A24-RBF	9.20kg	-7080K	151.00
230 x 3 x 22.23	A24-RBF	15.0kg	-8080K	168.00
230 x 3 x 22.23	C24-RBF	14.6kg	-8800K	168.00
350 x 3 x 25.4	A36-RBF	34.6kg	-9920K	331.00

Inox Cut-Off Discs

For stainless steel (iron, chlorine and sulphur-free).

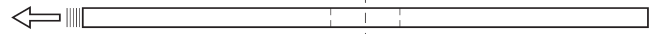

Diameter x Thickness x Bore (mm)	Grade	Order Code KEN-230	Price/1 TB
100 x 1.0 x 16.00	AS60T-INOX-BF	-4410K	80.00
115 x 1.0 x 22.23	AS60T-INOX-BF	-4430K	91.00
115 x 1.6 x 22.23	AS46T-INOX-BF	-4440K	102.00
125 x 1.0 x 22.23	AS60T-INOX-BF	-4460K	116.00
125 x 1.6 x 22.23	AS46T-INOX-BF	-4470K	121.00
180 x 1.6 x 22.23	AS46T-INOX-BF	-4500K	168.00
230 x 1.9 x 22.23	AS46T-INOX-BF	-4540K	199.00



Depressed Centre Cutting & Grinding Discs

A quality range of depressed centre cutting and grinding discs that offer professional performance and assure operator safety. For use with all portable grinders. Manufactured to European safety standards.

Note: Cutting discs not to be used for grinding.

Cutting discs: Type 42.
Grinding discs: Type 27.

Type	Size (mm)	Grade	Pack Quantity	Order Code SEN-230	Price/1 TB
Cutting	100 x 3 x 16	A24RBF	10	-1030K	299.00
	115 x 3 x 22.23	A24RBF	10	-1130K	350.00
Grinding	100 x 6 x 16	A30TBF	5	-1060K	250.00
	115 x 6 x 22.23	A30TBF	5	-1160K	299.00



PRODUCTS ARE ONLY AVAILABLE VIA YOUR DISTRIBUTOR

How a Grinding Wheel is Defined

Any grinding wheel is defined by three specific pieces of information:

(1) The Wheel Size

Wheel size is the measure of the overall diameter, wheel thickness and hole diameter quoted in mm:

Diameter (D) x Thickness (T) x Bore (B)

Diameter and thickness are usually represented as nominal dimensions but the bore size is given to two decimal places.

(2) The Shape and Minor Dimensions

Grinding wheels are available in a vast range of shapes. Below are several examples of International Standard Shapes:

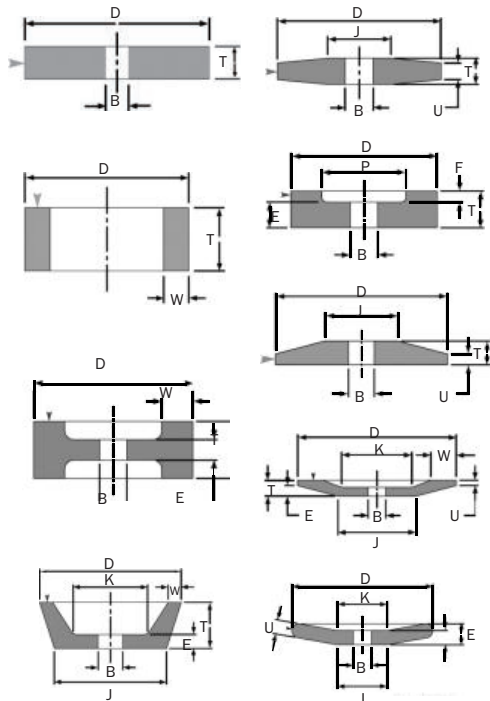

(3) Designation
The specification of a grinding wheel is given by the designation mark which is made up of six basic parts:

ALUMINIUM OXIDE		
Friable	White	WA
	Pink	41A
	Ruby	46A
	Pink	48A
Regular		A
	Rubemite	RA
	Mixtures	MA (WA+A)
SILICON CARBIDE		
Regular		C
*Black		BC

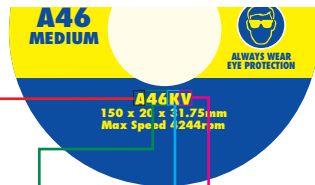

Grain Size	Grade	Bond Type	
COARSE	SOFT	VITRIFIED	
8	E	V	
10	F		
14	G		
16	H		
20	I		
24	MEDIUM	RESINOID	
30	J	B	
46	K		
36	L		
	M	RUBBER	
60	HARD		R
80	N		
100	O		
120	P		
150	Q		
FINE	R	SHELLAC	
180	VERY HARD	E	
220	S		
240	T		
280	U		
VERY FINE	V		
320	W		
400	X		
500	Y		
600	Z		

Abrasive Types

Regular Aluminium Oxide

Tough form of aluminium oxide which contains 3% titanium oxide. Further oxidation of the titanium oxide occurs at temperatures above 1250°C causing the colour to change from the usual brown to a grey-blue. Suitable for grinding high tensile strength materials.

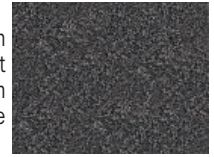

White Aluminium Oxide

Produces wheels with high friability (the ability to fracture, exposing sharp cutting edges) due to the highly refined aluminium oxide containing over 99% pure alumina. Suitable for precision grinding hardened or HSS materials.

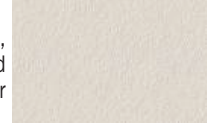

Semi-Friable Aluminium Oxide

Produces wheels using an abrasive with friability, toughness and free cutting characteristics. With good form holding and a high degree of versatility making 48A abrasive suitable for cylindrical, centreless, crankshaft and angle head grinding.



Pink Aluminium Oxide

Produces wheels that have highly refined aluminium oxide containing less than 0.3% of chromium oxide. A pink colour wheel, tougher and less friable than white abrasive while still retaining free cutting properties. Suitable for grinding high alloyed tool steels especially when a cooler grinding action is required.



Rubemite Aluminium Oxide

High performance aluminium oxide abrasive used on shank mounted points and wheels. With free cutting characteristics. Suitable for general purpose grinding of steels and most metals.



Silicon Carbide

Wheels that are harder than aluminium oxide type abrasives but brittle. Suitable for grinding low tensile strength materials such as cast iron, non-ferrous metals and non-metallic materials. Silicon carbide is available in three varieties with very similar physical properties. They are distinguished by colour; dark green (DC) the most commonly used, black silicon carbide (BC) is for roughing operations and light green carbide (GC) for specific applications.



Abrasive Mixtures

By mixing different types of abrasives a large range of wheels can be produced with very different characteristics to meet specific needs.

Grain Size

The grain or grit size is important for determining a wheel's ability to produce the required surface finish and stock removal. Grain size is denoted by a number which increases as grain sizes decrease, i.e. 10 grit, grain size = 2.00mm, 60 grit, grain size = 0.25mm. Standard sizes are used for all wheels in Europe as specified in the European Standards laid down by FEPA (Federation of European Producers of Abrasive Products).

A wheel will have the following characteristics as the grit size is made progressively finer:

- It will cut more slowly.
- It will produce a finer surface finish.
- It will be more resistant to dressing by the component being ground.
- It will be more likely to produce chatter marks if the grade is too hard.
- The minimum form radius that can be ground will decrease.

A coarser grit wheel will act in the following way:

- It will be freer cutting.
- It will produce a coarser surface finish.
- It will be less resistant to dressing by the workpiece.
- The minimum form radius that can be ground will increase.

Bond Type

Vitrified Bond: These wheels have a porous structure of abrasive particles bonded together by bridges of glass or similar vitreous material. Other fusible materials are used in formulating bonds to produce a wide range of structures each with its own characteristics. The wheels are kiln fired at temperatures exceeding 1000°, because of this they are unaffected by heat generated during normal grinding processes. Suitable for precision grinding due to their high rigidity, they can be fractured by mechanical forces.

Organic Bonds: Organic bonds such as resinoid, rubber and shellac are cured at relatively low temperatures, when compared to vitrified bonds. Their resistance to mechanical forces can be affected by the heat generated when grinding causing the wheel to wear quickly or fracture easily. This can be altered by controlling the heat resistance of the bond.

Resinoid Bond: Based on thermosetting phenolic resin, to which fillers may be added to improve the mechanical properties of the wheel. As these wheels are tougher and less rigid than vitrified wheels, they are suitable for heavy stock removal. They also produce finer finish.

Rubber Bond: Rubber bonded wheels are suitable for grinding operations where a fine finish is necessary and on wet cutting off operations where a high degree of accuracy and quality of cut are required. Used for most centreless control wheels.

Shellac Bond

These wheels are cool cutting and produce very fine finishes. This makes them particularly suitable for applications with minimal heat generation or for grinding very soft materials such as copper.



YORK ABRASIVES **Grinding Wheels**

Vitrified bond for precision grinding. Unaffected by water, acid and oils. All 1 1/4" bore, supplied with 1", 7/8", 3/4", 5/8" and 1/2" bore nylon bushes.



All York grinding wheels are supplied in a unique storage box, which helps prevent chipping and other accidental damage. Spare cases available below.



Spare Storage Box

Type	Order Code YRK-235	Price/1 TB
For up to 8"/200mm grinding wheels	-9000K	213.00

Reducing Bush Set

Contents	Order Code YRK-235	Price/1 TB
1/2", 5/8", 3/4" & 1"	-9010K	189.00

Type 1 Plain

Diameter x Thickness	Grade	Weight each	Order Code YRK-235	Price/1 TB
1 1/4" Bore				
100 x 6	WA80KV Med	0.25kg	-0030K	259.00
127 x 6	WA60KV Med	0.30kg	-0040K	295.00
	WA100KV Med	0.30kg	-0045K	369.00
127 x 13	GC80KV Med	0.40kg	-0050K	439.00
150 x 6	WA60KV Med	0.30kg	-1110K	439.00
	WA100KV Med	0.30kg	-1130K	439.00
150 x 13	A46NV Med	0.55kg	-1530K	339.00
	A60NV Med	0.55kg	-1550K	333.00
	A80NV Med	0.55kg	-1580K	333.00
	WA60KV Med	0.55kg	-1620K	502.00
	WA100KV Med	0.55kg	-1625K	552.00
	GC60JV Soft	0.55kg	-1630K	620.00
150 x 16	A46NV Med	0.65kg	-1730K	640.00
	A60NV Med	0.65kg	-1750K	640.00
	GC60JV Soft	0.65kg	-1780K	690.00
	GC100JV Soft	0.65kg	-1800K	690.00
150 x 20	A36OV Med	0.80kg	-2010K	707.00
	A36PV Hard	0.80kg	-2020K	707.00
	A46NV Med	0.80kg	-2030K	707.00
	A60NV Med	0.80kg	-2050K	707.00
	A60PV Hard	0.80kg	-2060K	707.00
	A80NV Med	0.80kg	-2070K	707.00
	WA60KV Med	0.80kg	-2090K	707.00
	GC60JV Soft	0.80kg	-2110K	707.00
	GC80JV Soft	0.80kg	-2120K	707.00
	GC100IV Soft	0.80kg	-2130K	815.00
150 x 25	A60NV Med	1.10kg	-2350K	876.00
	GC60JV Med	1.10kg	-2380K	876.00
180 x 6	WA60KV Med	0.40kg	-2400K	376.00
	WA100KV Med	0.40kg	-2410K	502.00
	A46NV Med	0.80kg	-2440K	595.00
	GC60JV Soft	0.80kg	-2460K	595.00
180 x 13	GC100IV Soft	0.80kg	-2470K	595.00
	WA46HV Soft	0.80kg	-2480K	595.00
	WA46JV Med	0.80kg	-2490K	595.00
	WA46KV Med	0.80kg	-2500K	608.00
	WA60JV Soft	0.80kg	-2510K	690.00
	WA60KV Med	0.80kg	-2520K	690.00
	WA80JV Soft	0.80kg	-2528K	690.00
	WA80KV Med	0.80kg	-2530K	690.00
	WA100KV Med	0.70kg	-2540K	690.00
	A60NV Med	1.20kg	-2550K	707.00
180 x 20	WA46KV Med	1.20kg	-2560K	707.00
	WA60KV Med	1.20kg	-2570K	707.00
	WA80KV Med	1.20kg	-2580K	707.00
200 x 13	GC60JV Soft	1.20kg	-2590K	940.00
	WA46KV Med	0.90kg	-2596K	815.00
	WA60KV Med	0.90kg	-2600K	815.00
200 x 20	WA80KV Med	0.90kg	-2610K	815.00
	A36NV Med	1.40kg	-2616K	876.00
	A36PV Hard	1.40kg	-2620K	876.00
	A46NV Med	1.40kg	-2630K	876.00
	A46PV Hard	1.40kg	-2640K	876.00
	A60NV Med	1.40kg	-2650K	876.00
	A60PV Hard	1.40kg	-2660K	876.00
	WA46KV Med	1.40kg	-2680K	876.00
	WA60KV Med	1.40kg	-2700K	876.00
	GC60JV Soft	1.40kg	-2710K	1288.00
200 x 25	A36PV Hard	1.80kg	-2820K	1288.00
	A46NV Med	1.80kg	-2830K	1288.00
	A46PV Hard	1.80kg	-2840K	1288.00
	A60NV Med	1.80kg	-2850K	1288.00
	A60PV Hard	1.80kg	-2860K	1288.00
	A80NV Med	1.80kg	-2870K	1288.00
	GC60JV Soft	1.80kg	-2910K	1391.00
	GC80JV Soft	1.80kg	-2920K	1391.00
	GC100IV Soft	1.80kg	-2930K	1391.00
	GC120JV Soft	1.80kg	-2940K	1391.00
3" Bore				
250 x 20	WA46KV Med	2.50kg	-3240K	1565.00
256 x 20	WA60KV Med	2.50kg	-3260K	1565.00
	A36MV Med	3.05kg	-3300K	1877.00
	A36NV Hard	3.05kg	-3320K	1877.00
	A46MV Med	3.05kg	-3340K	1877.00
	A60MV Med	3.05kg	-3360K	1877.00
	WA46JV Med	3.05kg	-3420K	1877.00
	WA46KV Med	3.05kg	-3440K	1877.00
	WA60KV Med	3.05kg	-3460K	2065.00
	GC60JV Med	3.05kg	-3500K	2065.00
	GC60KV Med	3.05kg	-3520K	2065.00
256 x 25	GC80JV Med	3.05kg	-3540K	2065.00
	GC100IV Soft	3.05kg	-3580K	2065.00
	WA46KV Med	3.65kg	-4260K	3128.00
	WA60KV Med	3.65kg	-4280K	3128.00
	WA100KV Med	3.65kg	-4320K	3128.00
	A36NV Hard	5.20kg	-4520K	4378.00
300 x 25	A46MV Med	5.20kg	-4560K	4378.00
	A60MV Med	5.20kg	-4600K	4378.00
300 x 33	A36NV Hard	5.20kg	-4520K	4378.00
	A46MV Med	5.20kg	-4560K	4378.00

ABRASIVES & POWER TOOLS

PRODUCTS ARE ONLY AVAILABLE VIA YOUR DISTRIBUTOR

GROUP 240 JIGSAW BLADES



Manufactured from high quality steels to meet the demands of most industrial and DIY applications. Supplied display carded. High teeth per inch (TPI) blades will be slower cutting and produce a better edge finish. Low teeth per inch blades will be faster cutting but produce coarse edges on the workpiece. Different materials will also give different edge finishes depending on the make up of the material and direction of cut in relation to the direction of the grain. When cutting certain metals, lubricant or grease may be required to reduce friction and dissipate heat. Various techniques can be employed to prevent splintering of cut edges on wood, especially laminated materials. These include the use of an anti-splinter guard. This is a plastic insert that locates in the jigsaw base plate, reducing the gap around the blade and the splinter area. Another technique is to score a guide line on the wood. This creates a pre-cut line that must then be followed accurately. The last technique is to place adhesive tape over the proposed cut line. This holds the material in place whilst the cut is being made.

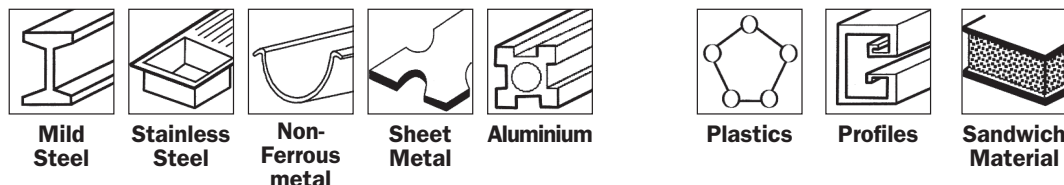

EXTENDED RANGE

Capacity (mm)		Tooth Pitch	Effective Length (mm)	Features/Recommendations	Equiv.	Order Code KEN-240	Price/Pk TB
Steel	Wood						
HSS - Heavy Duty (Pack 5)							
-	-	10.0	20.0	2.0	75	Tapered & Ground T101A	-1010K 438.00
1.54.0	-	1.54.0	8.0	1.2	48	Way Set Teeth T118A	*-1160K 266.00
1.54.0	-	1.54.0	-	1.2	48	Way Set Teeth T218A	-2180K 321.00
2.0	-	2.0	-	0.7	50	Way Set Teeth T118G	-1180K 266.00
3.06.0	-	3.0-15.0	30.0	3.0	75	Side Set Teeth T127D	*-1270K 290.00
3.06.0	-	3.0-10.0	-	2.0	48	Way Set Teeth T118B	*-1170K 266.00
3.06.0	-	3.0-10.0	-	2.0	100	Way Set Teeth T318B	-3190K 455.00
3.06.0	-	3.0-15.0	30.0	3.0	75	Side Set Teeth T227D	-2270K 364.00
4.0	-	1.54.0	-	1.2	100	Way Set Teeth T318A	-3180K 407.00
10.0	-	10.0	-	2.6	75	Way Set Teeth T123X	-1240K 232.00
10.0	10.0	10.0	-	5.0	110	Way Set Teeth T1345X	-3450K 335.00
Bi-Metal - High Performance (Pack 5)							
1.54.0	-	1.54.0	8.0	1.2	50	Way Set Teeth T118AF	-1150K 337.00

***Best Sellers are also available in 'Contractor Packs' of 20 blades - See below**



PACK OF 5

ABRASIVES & POWER TOOLS

'Contractor Packs'

The most popular 'T' style blades bulk packed in 20s for economy. Supplied in telescopic 'pocket' cases that are ideal for the industrial user.



PACK OF 20

Capacity (mm)		Tooth Pitch	Effective Length (mm)	Features	Equiv.	Order Code KEN-240	Price/Pk TB
Steel	Wood						
HSS - Heavy Duty (Pack 20)							
1.5-4.0	-	1.5-4.0	8.0	1.2	48	Way Set Teeth	T118A -1165K 1042.00
3.0-6.0	-	3.0-10.0	-	2.0	48	Way Set Teeth	T118B -1175K 1042.00
3.0-6.0	-	3.0-15.0	30.0	3.0	75	Side Set Teeth	T127D -1275K 1153.00

EXTENDED RANGE



Recommendations:

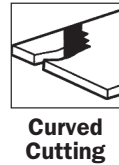
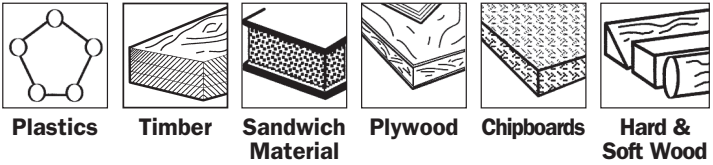

'T' Type Shank
 'T' Style or bayonet fitting as used by AEG, Atlas Copco, Bosch, Dewalt, Elu, Hitachi, Holz-Her, Kobe, Makita, Metabo and Osaki.

Capacity (mm)	Effective Tooth Length (mm)	Features/Recommendations	Equiv.	Order Code	Price/Pk
Wood	Plastics	Pitch		KEN-240	TB
HCS - Medium Duty (Pack 5)					
Wavy Set Teeth					
15.0	8.0	1.2	48	T119A	-1190K 142.00
Ground Set Teeth					
15.0	-	1.4	50	T101AOF-1017K	258.00
Tapered & Ground					
15.0	-	1.4	50	T101AO	-1015K 227.00
Wavy Set Teeth					
20.0	20.0	2.5	50	T119B0	-1210K 191.00
Wavy Set Teeth					
30.0	20.0	2.0	48	T119B	-1200K 142.00
Tapered & Ground					
30.0	-	2.5	75	T101BRF-1035K	284.00
Tapered & Ground					
50.0	30.0	2.5	64	T101BR	-1030K 290.00
Tapered & Ground					
50.0	30.0	2.5	75	T101B *	-1020K 266.00
Ground & Side Set					
50.0	-	4.0	75	T144DP	-1450K 205.00
Side Set Teeth					
60.0	30.0	3.0	75	T111C *	-1110K 142.00
Tapered & Ground					
60.0	30.0	4.0	75	T101D	-1040K 261.00
Tapered & Ground					
60.0	50.0	4.0	75	T144D *	-1440K 191.00
Side Set Teeth					
60.0	50.0	4.0	75	T244D	-2440K 228.00
Tapered & Ground					
65.0	-	3.0	90	T234X	-2340K 258.00
Tapered & Ground					
70.0	50.0	4.0	85	T301D	-3010K 304.00
Bi-Metal - High Performance (Pack 5)					
60.0	30.0	4.0	70	Combi	-3320K 472.00
Cuts on Both Edges	1.8	40			

Jigsaw Blade Assortment

'T'-Shank - Fits 90% of all current jigsaw makes and models including Bosch, DeWalt, Hitachi, Kobe, Makita and Osaki. Supplied in a tough plastic storage case. Contains one of each of the most popular wood cutting blades:
 Clean cut wood blades: **T101AO, T101B, T101BR, T101AOF, T101BF, T101BRF.**
 Speed cut wood blades: **T144D, T244D.**
 Speed cut hardwood blades: **T144DF.**
 Precision cut wood blades: **T144DP.**

NEW



PACK OF 10

Description	Order Code	Price/Pk
	KEN-240	TB
Assorted set of Jigsaw Blades (Pack of 10)	-5620K	411.00

***Best Sellers are also available in 'Contractor Packs' of 20 blades - See below**

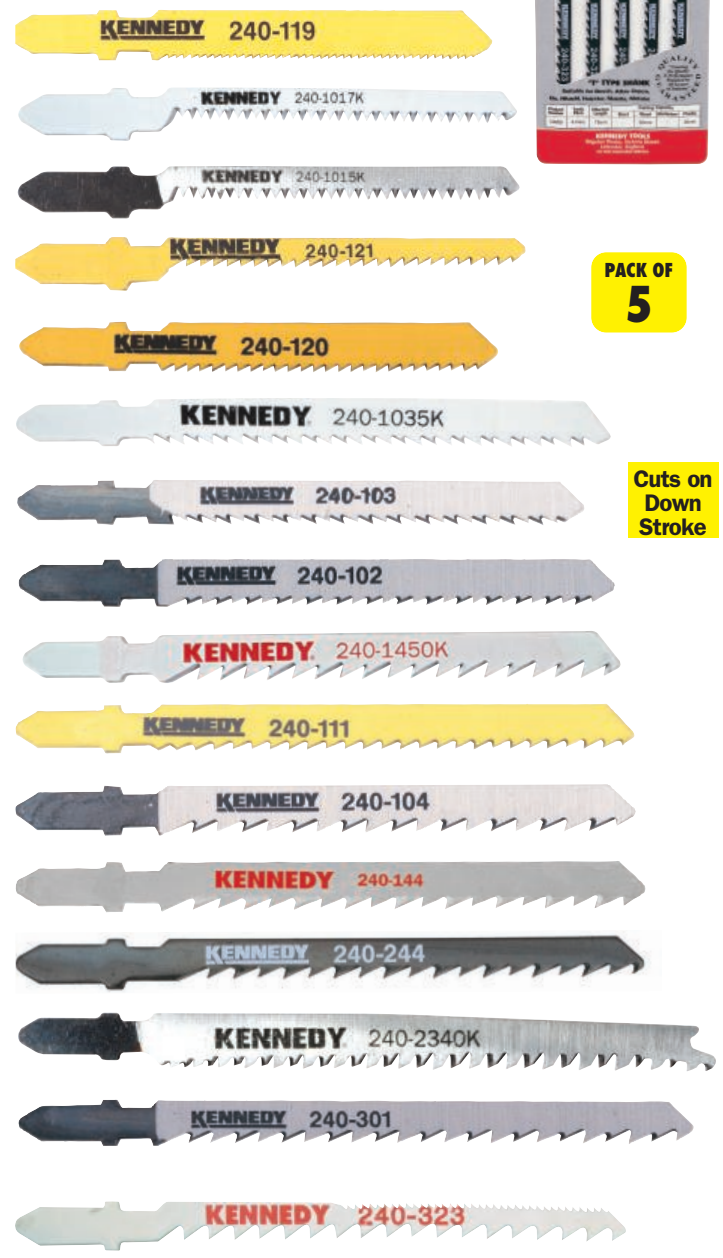

PACK OF 5

Cuts on Down Stroke

ABRASIVES & POWER TOOLS

'Contractor Packs'

The most popular 'T' style blades bulk packed in 20's for economy. Supplied in telescopic 'pocket' cases that are ideal for the industrial user.



PACK OF 20

Capacity (mm)	Effective Tooth Length (mm)	Features	Equiv.	Order Code	Price/Pk
Wood	Plastics	Pitch		KEN-240	TB
HCS - Medium Duty (Pack 20)					
50.0	30.0	2.5	75	Tapered & Ground	T101B -1025K 1045.00
60.0	30.0	3.0	75	Side Set Teeth	T111C -1115K 450.00
60.0	50.0	4.0	75	Tapered & Ground	T144D -1445K 750.00

PRODUCTS ARE ONLY AVAILABLE VIA YOUR DISTRIBUTOR

GROUP 245 FIBRE ABRASIVES



Fibre Hand Pads

A range of non-woven fibre hand pads for cleaning, blending and finishing applications. Supplied in packs of 10.

Size: 155 x 225mm.

White - Non-abrasive: for the removal of oxides and coatings, produces a scratch-free finish.

Grey - XX-Fine Pad: for light finishing on all minerals as well as lacquer de-nibbing.

Maroon - X-Fine: general-purpose conformable hand pad which gives a finer finish than the Green hand pad.

Green - Fine: general-purpose hand pad for cleaning and finishing. It can also be used for lacquer de-nibbing and matt finishing on solid surfaces.

Black - Medium: for medium to coarse finishing and blending.

Brown - Coarse: heaviest duty pad in the range. Used for light deburring, cleaning and finishing applications, e.g. deburring edges of sheet materials to improve handling.

Pack of 6

Handy book with one of each: white, grey, maroon, green, black and brown.



Colour	Grade	Size (mm)	Order Code YRK-245	Price/10 TB
White	Non		-2080K	561.00
Grey	XX-Fine	155 x 225	-2100K	592.00
Maroon	X-Fine		-2060K	561.00
Green	Fine		-2040K	561.00
Black	Medium	155 x 225	-2000K	616.00
Brown	Coarse		-2020K	989.00
Pack of 6		155 x 225	-3000K	313.00

Non-Woven Roll

Non-woven roll for cleaning, blending and finishing.



Colour	Grade	Size (mm x m)	Order Code YRK-245	Price/1 TB
Maroon	X-Fine		-1600K	1066.00
Green	Fine	100 x 10	-1640K	1495.00
Black	Medium		-1620K	1495.00
Maroon	X-Fine		-1700K	2055.00
Green	Fine	150 x 10	-1740K	2055.00
Black	Medium		-1720K	2055.00

Industrial Steel Wire Wool

Available in a choice of seven grades for industrial, household, and trade use. For the preparation of surfaces between coats, use the wire wool dry. For removing paint spots, use with a white spirit, turpentine or liquid paint remover. For household work, use with soap and water as required. Suitable for use with metallic pots and pans. Always wear gloves.

Applications:

000 - Very Fine: dulling of varnish, polishing metals and car bodies.

00 - Fine: between coats of paint and polishing wooden surfaces.

0 - Fine: general-purpose.

1 - Medium: preparation prior to painting or varnishing.

2 - Medium: general-purpose.

3 - Coarse: removal of paint, varnish, rust etc.

4 - Very Coarse: rubbing down wooden surfaces, preparation of car bodies/exterior surfaces.

Rust Removal

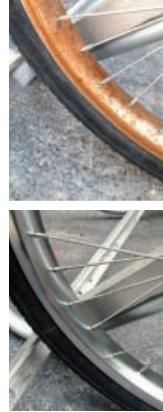

EXTENDED RANGE



Pack Size	Grade	Order Code YRK-245	Price/1 TB
200g	000 - Very Fine	-1210K	155.00
	00 - Fine	-1220K	150.00
	0 - Fine	-1230K	134.00
	1 - Medium	-1240K	124.00
	2 - Medium	-1250K	124.00
450g	3 - Coarse	-1260K	124.00
	4 - Very Coarse	-1270K	124.00
	000 - Very Fine	-1010K	261.00
	00 - Fine	-1030K	229.00
	0 - Fine	-1050K	229.00
450g	1 - Medium	-1070K	229.00
	2 - Medium	-1090K	229.00
	3 - Coarse	-1110K	229.00
	4 - Very Coarse	-1130K	229.00

SENATOR Fibre Hand Pads

Non-woven Hand Pads

For cleaning, blending and finishing applications.

Green - fine: General-purpose pads for cleaning and finishing. Can also be used for lacquer de-nibbing and matt finishing on solid surfaces.

Maroon - X-fine: General-purpose pads which give a finer finish than the Green hand pad.

NEW

PACK OF 10

Colour	Pack Quantity	Order Code SEN-245	Price/Pk TB
Green	10	-6010K	499.00
Maroon	10	-6020K	499.00

Shaft Mounted Combi Wheels



Made from high quality nylon, which is both flexible, durable and does not clog as easily as standard abrasive. 6mm shank diameter. Ideal for matching/blending a finish, light deburring, decorative/cosmetic applications. Alternate flaps of abrasive are interleaved with a versatile high quality nylon. 6mm shank diameter. Suitable for: deburring, producing cosmetic finishes on most materials, rust removal and blending.

Finishing Wheels

Diameter x Width (mm)	Grade	Order Code YRK-245	Price/1 TB
50 x 25	Coarse	-8310K	405.00
	Medium	-8320K	405.00
	Fine	-8330K	405.00
50 x 50	Very Fine	-8340K	405.00
	Coarse	-7560K	561.00
	Medium	-7570K	561.00
60 x 30	Fine	-7580K	561.00
	Very Fine	-7590K	561.00
	Medium	-7620K	624.00
76 x 25	Medium	-8370K	459.00
	Fine	-8380K	459.00
	Very Fine	-8390K	459.00
76 x 50	Coarse	-8410K	459.00
	Medium	-8420K	666.00
	Very Fine	-8440K	566.00
100 x 50	Medium	-7770K	706.00
	Fine	-7780K	706.00

Interleaved Wheels

Diameter x Width (mm)	Grade	Order Code YRK-245	Price/1 TB
50 x 25	Coarse	-8710K	518.00
	Medium	-8720K	518.00
	Fine	-8730K	492.00
50 x 50	Very Fine	-8740K	492.00
	Coarse	-7960K	561.00
	Medium	-7970K	561.00
60 x 30	Fine	-7980K	561.00
	Very Fine	-7990K	561.00
	Coarse	-8010K	459.00
76 x 25	Medium	-8020K	459.00
	Fine	-8030K	459.00
	Very Fine	-8760K	704.00
76 x 50	Medium	-8770K	704.00
	Fine	-8780K	704.00
	Very Fine	-8790K	704.00
100 x 50	Coarse	-8810K	704.00
	Medium	-8820K	704.00
	Fine	-8830K	704.00
100 x 50	Coarse	-8160K	1059.00
	Medium	-8170K	1059.00
	Fine	-8180K	1059.00
	Very Fine	-8190K	1059.00

York Abrasive Blocks

Rubber sanding blocks impregnated with abrasive. Remains abrasive throughout the block. For industrial sanding/cleaning components and surfaces.



Grade	Weight each	Order Code YRK-245	Price/1 TB
Fine	141g	-4000K	331.00
Medium	110g	-4010K	331.00
Coarse	119g	-4020K	393.00
X-Coarse	122g	-4030K	393.00

YORK ABRASIVES

Clean & Strip Unitised Wheels

Cleans surfaces faster and more effectively than wire brushes, scrapers or pickling pastes. Produced by adhesively bonding and compressing web together to form a slab from which wheels are then cut. High stock removal producing a very good finish. As there are no metal components used in the manufacture of these wheels, accidental damage to the work piece is eliminated. Ideally suitable for preparation and cleaning of welds, rust removal and removal of discolouration.

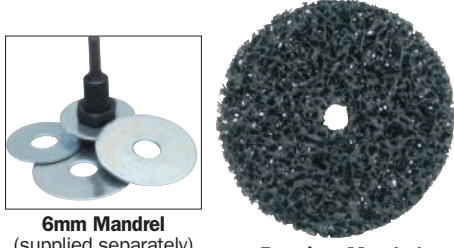

6mm Mandrel
(supplied separately)

Requires Mandrel

Size x Bore (mm)	Grade	Max. RPM	Order Code YRK-245	Price/1 TB
100 x 12		5,500	-5020K	243.00
150 x 12	X/Coarse	3,500	-5040K	437.00
200 x 12		2,500	-5060K	686.00

	Order Code YRK-280	Price/1 TB
6mm Mandrel for clean strip wheel	-5010K	926.00

Clean & Strip Unitised Discs

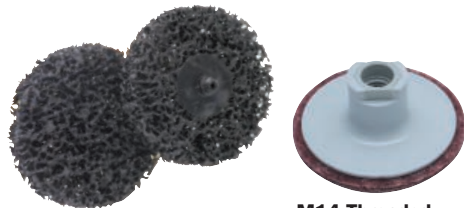

Requires Backing Pad

M14 Threaded Backing Pad
(supplied separately)

Size (mm)	Grade	Maximum RPM	Order Code YRK-245	Price/1 TB
75	X/Coarse	10,000	-5310K	335.00
Backing Pad - M14 Thread				-3510K 567.00

Clean & Strip Discs Kit

Contents	Grade	Max. RPM	Order Code YRK-245	Price/1 TB
4x 75mm Discs				
1x 12 M14 Backing Pad	X/Coarse	10,000	-9100K	2215.00

Surface Preparation & Polishing Kit

Contents:

1x M14 backing pad, 1x surface conditioning discs brown (CRS), 1x surface conditioning disc in maroon (medium), blue (very fine) and grey (ultra fine), 1x felt disc (white), 1x bar of compound (yellow).

7 PIECES



Number of Pieces	Order Code YRK-245	Price/1 TB
7	-9200K	1495.00

XL Unitised Wheels

Produced by adhesively bonding and compressing web together to form a slab from which wheels are then cut.

Maximum RPM:
76mm diameter: 9,500.
152mm diameter: 4,700.
Density grade: 2SFIN.

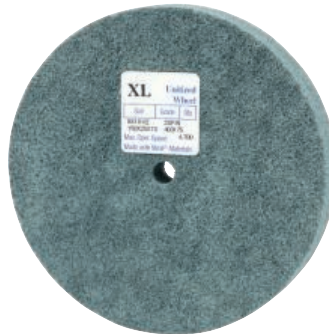

Nominal Size (mm)	Weight per 10	Order Code YRK-245	Price/1 TB
76 x 12 x 6.5	250g	-6550K	561.00
76 x 25 x 6.5	540g	-6570K	922.00
152 x 6 x 12.7	590g	-6610K	1184.00
152 x 12 x 12.7	1080g	-6630K	2055.00
152 x 25 x 12.7	2160g	-6650K	5166.00

XL Unitised Discs

Ideal for use on portable hand and power tools for working on intricate shapes. Main applications include deburring, blending and finishing on a variety of materials. Suitable for use with all types of portable drills, grinders etc. Can be used as a disc or wheel.



Nominal Size	Grade	MOS RPM	Order Code YRK-245	Price/1 TB
50 x 6mm	Fine	22,100	-6810K	243.00

Surface Preparation & Finishing Discs

A complete range of flexible surface preparation discs from coarse grit through to a fine polishing disc allows you to rapidly and consistently achieve the finish you require. Ideal for rust removal, preparing and cleaning welds. The threaded mounting allows rapid disc change when required.

Diameter: 75mm.

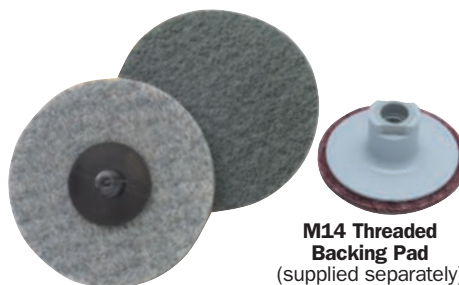

M14 Threaded Backing Pad
(supplied separately)

Grade	Colour	Order Code YRK-245	Price/1 TB
Ultra Fine	Grey	-3640K	119.00
Polishing	White	-3700K	131.00
Backing Pad M14 Thread -3510K 567.00			

FIBRE ABRASIVES

Surface Conditioning Discs

Fibre-Backed

For removing grinding marks and scratches leaving a greatly improved surface finish. For use with a regular (sanding disc) flexible backing pad.



Nominal Size	Grade	MOS RPM	Order Code YRK-245	Price/1 TB
100mm	Coarse	18,000	-6110K	188.00
115mm	Coarse	13,000	-6150K	268.00
178mm	Coarse	6,000	-6200K	492.00

Hook-n-Loop Scrim-Backed

For removing grinding marks and scratches leaving a greatly improved surface finish.

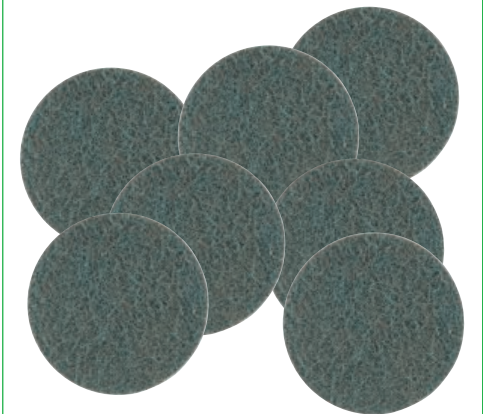

Nominal Size	Grade	MOS RPM	Order Code YRK-245	Price/1 TB
100mm	Fine	18,000	-6010K	139.00
	Med		-6020K	775.00
	Coarse		-6030K	140.00

Rigid Backing Pad

To suit scrim backed surface conditioning discs. M14 female thread.

Size: 100mm x M14.

Nominal Size	Order Code YRK-280	Price/1 TB
100mm x M14	-4100K	937.00

Rust & Paint Removal Disc

Made of intertwined nylon fibres which are then immersed in synthetic resin and gently hardened. Ideal for removing old paint, rust and welding splatter without scratching the surface of the workpiece, cleaning and smoothing wood and plastic, polishing of stainless steel and removal of thermal bluing.

DIN EN 13743.



Size x Bore (mm)	Maximum RPM	Order Code YRK-245	Price/1 TB
115 x 22	10,500	-3800K	468.00

ABRASIVES & POWER TOOLS

YORK ABRASIVES

Pre-Finish & Polishing Bars

General-Purpose Polishing

High quality ingredients combine to produce this bar for rapid working to give a mirror finish on non-ferrous metals and plastics.



Product Number	Size	Order Code YRK-247	Price/1 TB
PGP100	1000g	-8000K	308.00

Fast Cutting Pre-Finish

Medium greasy in composition with iron free abrasives for fast cutting when used with our sisal mops. Its consistency will often negate the need for scrubbing or abrasion and produce a matt finish without drag lines.



Product Number	Size	Order Code YRK-247	Price/1 TB
FFC080	800g	-8020K	258.00

Felt Bob Finishing Set

Supplied in a stylish and robust case.

21 Piece Set Contents:

Cylindrical

3mm shank: 19 x 19mm x1 and 18 x 20mm x1; 6 x 10mm x2, 6 x 14mm x2, 12 x 7mm x2 and 12 x 24mm x2.

6mm shank: 18 x 38mm x1; 12 x 24mm x2 and 24 x 24mm x2.

Taper Plain End

3mm shank: 12 x 20mm x2.

6mm shank: 19 x 25mm x2 and 25 x 30mm x2.

Cone

3mm shank: 9 x 14mm x1.

Also included:

SM-51224 - 3mm Collet.

SM-51224 - 6mm Collet.

Polishing Bar Compound: 110g.

NEW

21 PIECES



Number of Pieces	Weight each	Order Code YRK-247	Price/1 TB
21	250g	-9100K	2250.00

Bright Shine Pre-Finish

This bar has a composition that gives good cutting characteristics and also leaves a bright finish when used with our sisal mops.



Product Number	Size	Order Code YRK-247	Price/1 TB
FBS080	800g	-8040K	258.00

Fast Cutting Polishing Bar

This composition produces a superb fast cutting bar to give a final polish on stainless steels, chrome plate and non-ferrous metals. Used generally for commercial finishes because it is clean to use and clears well.



Product Number	Size	Order Code YRK-247	Price/1 TB
PFC100	1000g	-8060K	308.00

Mirror Finish Polishing Bar

This bar has a composition that produces a superb mirror finish on stainless steels, chrome plate and non-ferrous metals.



Product Number	Size	Order Code YRK-247	Price/1 TB
PMF100	1000g	-8080K	361.00

Synthetic Gloss Polishing Bar

High quality ingredients combine to produce this bar for rapid working to give a mirror finish on non-ferrous metals and plastics.



Product Number	Size	Order Code YRK-247	Price/1 TB
PSG080	800g	-8100K	308.00

ABRASIVES & POWER TOOLS

Felt Bobs

York Felt Bobs are made of pure wool in a variety of sizes, shapes. The mandrels are exactly centred for true-running operation. Suitable for product finishing/polishing with finishing/polishing compounds.



Felt Stick



Diameter x Length (mm)	Shank Size	Order Code YRK-247	Price/1 TB
Plain End Cylinder (Bob)			
6 x 10	3mm	-1040K	70.00
6 x 14	3mm	-1060K	56.00
12 x 7	3mm	-1100K	76.00
12 x 24	3mm	-1120K	76.00
12 x 24	6mm	-1140K	76.00
12.7 x 15	3mm	-1150K	76.00
13 x 13	3mm	-1160K	76.00
18 x 20	3mm	-1190K	91.00
18 x 38	6mm	-1200K	101.00
19 x 19	3mm	-1220K	78.00
24 x 24	6mm	-1250K	83.00
25 x 7	3mm	-1300K	88.00
Ball Nose			
12.70 x 12.70	3mm	-3940K	45.00
Ball Nose (Cone)			
9.00 x 14.00	3mm	-3080K	45.00
12.70 x 12.70	3mm	-3120K	32.00
25.00 x 25.00	6mm	-3220K	63.00
Felt Stick			
150.00 x 13.00	10mm	-0400K	313.00
150.00 x 20.00	10mm	-0420K	530.00
Tapered Plain End			
12.00 x 20.00	3mm	-3560K	45.00
19.00 x 25.00	6mm	-3720K	83.00
25.00 x 30.00	6mm	-3820K	83.00

Felt Bob Set

7 Piece Set Contents:

Cylindrical

3mm shank: 6 x 14mm, 12 x 7mm, 12 x 24mm and 25 x 7mm.

6mm shank: 12 x 24mm and 24 x 24mm.

Cylindrical Ball Nosed

3mm shank:

9 x 14mm.

Supplied in wooden storage box.



7 PIECES

Number of Pieces	Weight each	Order Code YRK-247	Price/1 TB
7	250g	-9070K	670.00

Silicon Carbide Valve Grinding Compound

For cutting brass, hardened steel and cast iron. Ideally used within the automotive and engineering industry. For heavy and light stock removal applications, from the removal of pits in exhaust pipes to the finishing of inlet valves.



*Contains 1x fine 85g and 1x coarse 85g

Size	Type	Order Code YRK-257	Price/1 TB
85g*	Fine/Coarse	-2100K	358.00
200g	Fine	-2010K	264.00
	Coarse	-2050K	264.00
500g	Fine	-2020K	335.00
	Coarse	-2060K	335.00



YORK ABRASIVES

Open Type Polishing Mops

Soft

Produces high quality finishes on non-ferrous metals such as brass, copper, aluminium and pewter. Can also be used on plastics for a medium finish. Best used with medium polishing pressure. Can be used with our fast cutting and mirror finish polishing bars.



Size	Order Code YRK-247	Price/1 TB
100 x 25mm	-4020K	168.00
150 x 25mm	-4040K	243.00
150 x 100mm	-4060K	644.00
Arbor To Suit	-6020K	109.00

Extra Soft

For use on plastics but are also suitable for gold and silver. Soft material is unsuitable for steel, stainless and non-ferrous metals. Performs well with a medium pressure and our synthetic gloss polishing bars.



Size	Order Code YRK-247	Price/1 TB
100 x 25mm	-4120K	258.00
150 x 25mm	-4140K	258.00
150 x 50mm	-4160K	492.00
Arbor to Suit	-6020K	109.00

Medium

For use with steel, brassware, nickel silver, copper, aluminium, chrome and plastics. Made in 13mm (1/2") sections, they will splay out when under pressure, ideal for work on uneven surfaces. Use with medium pressure and general-purpose polishing bar, fast cutting finishing bar and mirror finish polishing bar.



Size	Order Code YRK-247	Price/1 TB
100 x 12mm	-4220K	131.00
100 x 25mm	-4240K	232.00
150 x 25mm	-4260K	361.00
Arbor To Suit	-6020K	109.00

Stitched Type Polishing Mops

Untreated Sisal

Designed for heavy duty use including mopping operations on steel and non-ferrous metals. Ideal for the clearing of grinding/polishing marks from previous operations.



Size	Order Code YRK-247	Price/1 TB
150 x 13mm	-4320K	258.00
150 x 25mm	-4340K	361.00
150 x 50mm	-4360K	670.00
200 x 25mm	-4400K	562.00
200 x 50mm	-4420K	810.00
250 x 50mm	-4520K	1288.00
Arbor To Suit	-6020K	109.00

Polishing Mop Kits

A complete high performance surface finishing solution, producing a mirror finish in three stages. For use with drills, bench grinders or die grinders. All mops are plated to run cooler and carry more composition.

For Non-Ferrous Metals

Contents (1 of each): Secure holding arbor with a 6mm shank. Unstitched hard calico mop 100 x 12.5mm with 10 folds and a 9.5mm bore. Unstitched soft calico mop 100 x 12.5mm with 10 folds and a 9.5mm bore. 60g brown bar - general polishing composition. 60g blue bar - mirror finish polishing composition.

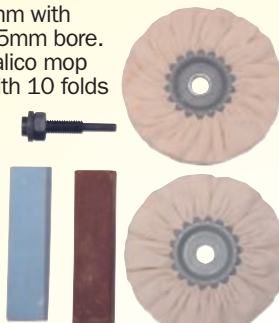

For Polishing	Order Code YRK-280	Price/1 TB
Non-Ferrous Metals	-9420K	1303.00

For Ferrous Metals

Contents (1 of each): Secure holding arbor with a 6mm shank. Stitched sisal mop 100 x 25mm with four sections and a 9.5mm bore. Unstitched hard calico mop 100 x 12.5mm with 10 folds and a 9.5mm bore. Unstitched soft calico mop 100 x 12.5mm with 10 folds and a 9.5mm bore. 60g dark brown bar - fast cutting composition. 60g pink bar - general polishing. 60g blue bar - mirror finish polishing composition.



For Polishing	Order Code YRK-280	Price/1 TB
Ferrous Metals	-9400K	1303.00

For Plastics

Contents (1 of each): Secure holding arbor with a 6mm shank. Unstitched hard calico mop 100 x 12.5mm with 10 folds and a 9.5mm bore. Unstitched soft calico mop 100 x 12.5mm with 10 folds and a 9.5mm bore. 60g brown bar - general polishing composition. 100g beige bar - general finishing composition.

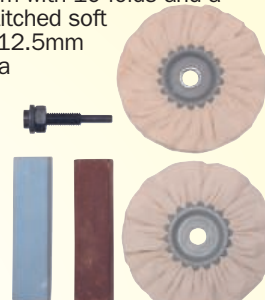

For Polishing	Order Code YRK-280	Price/1 TB
Plastics	-9440K	1303.00

For Woods

Contents (1 of each): Secure holding arbor with a 6mm shank. Denibbing disc 100 x 25mm with 4 sections and a 9.5mm bore. Unstitched hard calico mop 100 x 12.5mm with 10 folds and a 9.5mm bore. Unstitched soft calico mop 100 x 12.5mm with 10 folds and a 9.5mm bore. 100g beige bar - general finishing composition.

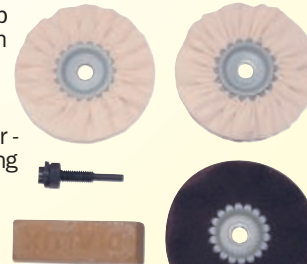

For Polishing	Order Code YRK-280	Price/1 TB
Woods	-9460K	1303.00

G-VA Polishing Flap Discs

Manufactured with high quality felt flaps. To be used with polishing compounds to produce polished mirror finishes on metal.



Size	Order Code YRK-247	Price/1 TB
115 x 22.23mm	-4720K	191.00
125 x 22.23mm	-4740K	212.00

Felt Flap Wheels

Made of pure wool in a variety of sizes and shapes. The mandrels are exactly centred for true-running operation. Suitable for product finishing/polishing with finishing/polishing compounds.

Diameter x Length	Order Code YRK-247	Price/1 TB
30 x 25mm	-5040K	271.00
40 x 25mm	-5050K	271.00
50 x 25mm	-5060K	288.00
60 x 25mm	-5070K	299.00
80 x 25mm	-5090K	380.00
30 x 30mm	-5140K	271.00
40 x 30mm	-5150K	271.00
50 x 30mm	-5160K	380.00
60 x 30mm	-5170K	429.00
80 x 30mm	-5190K	462.00

Polishing Compound

White: pre-polishing steel and stainless steel.

Blue: high gloss polishing.

Brown: pre-polishing of non-ferrous metals.



Colour	Size	Order Code YRK-247	Price/1 TB
Blue	110gm	-8420K	258.00
Brown	110gm	-8440K	258.00
White	110gm	-8470K	258.00
8 Piece Set - As above			-8500K 773.00

Shank: 6mm.



ABRASIVES & POWER TOOLS



'A' Shape
Shank
Diameter
6mm

Suitable for portable die and straight hand grinders. All points are aluminium oxide with 'Rubenite™' as standard for all general-purpose grinding and deburring on steels and most metals. Shank diameters are metric as listed below with inch sizes available on request. Maximum speeds are quoted assuming that collet to back of point does not exceed 12.7mm (1/2") and are for guidance only.

Shape	A1	A2	A3	A4	A5	A6	A8	A11	A12	A13	A14	A15	A21	A22
Grade	RA46	RA46	RA46	RA46	RA46	RA46	RA46	RA46	RA46	RA60	RA60	RA80	RA60	RA60
Diameter	20mm	25mm	25mm	32mm	20mm	19mm	21mm	18mm	18mm	28mm	18mm	6mm	25mm	19mm
Length	63mm	32mm	70mm	32mm	28mm	28mm	45mm	50mm	32mm	28mm	22mm	27mm	25mm	16mm
Max. rpm	20,000	38,000	16,000	30,000	45,000	39,000	20,000	20,000	48,000	34,000	55,000	55,000	34,000	51,000
Weight per 10	420g	380g	630g	440g	240g	240g	370g	470g	210g	390g	190g	100g	380g	200g
Price/1 TB	KEN-250-0010K	KEN-250-0020K	KEN-250-0030K	KEN-250-0040K	KEN-250-0050K	KEN-250-0060K	KEN-250-0080K	KEN-250-0110K	KEN-250-0120K	KEN-250-0130K	KEN-250-0140K	KEN-250-0150K	KEN-250-0210K	KEN-250-0220K
	91.00	53.00	141.00	67.00	45.00	51.00	78.00	91.00	67.00	83.00	51.00	46.00	59.00	60.00

Shape	A23	A24	A25	A26	A31	A32	A33	A34	A35	A36	A37	A38	A39
Grade	RA60	RA80	RA60	RA60	RA46	RA46	RA46	RA46	RA46	RA80	RA80	RA60	RA60
Diameter	19mm	6mm	25mm	16mm	35mm	25mm	25mm	38mm	25mm	40mm	32mm	25mm	19mm
Length	25mm	20mm	25mm	16mm	25mm	16mm	13mm	9mm	10mm	10mm	6mm	25mm	19mm
Max. rpm	39,000	70,000	35,000	60,000	25,000	38,000	38,000	25,000	38,000	23,000	30,000	35,000	47,000
Weight per 10	220g	100g	310g	150g	340g	230g	200g	280g	180g	230g	160g	370g	200g
Price/1 TB	KEN-250-0230K	KEN-250-0240K	KEN-250-0250K	KEN-250-0260K	KEN-250-0310K	KEN-250-0320K	KEN-250-0330K	KEN-250-0340K	KEN-250-0350K	KEN-250-0360K	KEN-250-0370K	KEN-250-0380K	KEN-250-0390K
	51.00	42.00	83.00	52.00	79.00	50.00	60.00	56.00	54.00	67.00	66.00	67.00	46.00

Shape	B41	B42	B43	B44	B45	B46	B47	B51	B52	B53	B54	B55	B61	B62	B63	B64
Grade	RA80	RA80	RA100	RA100	RA100	RA120	RA120	RA80	RA80	RA100	RA100	RA100	RA80	RA80	RA100	RA120
Diameter	16mm	13mm	6mm	6mm	5mm	3mm	3mm	12mm	10mm	8mm	6mm	3mm	19mm	13mm	6mm	6mm
Length	16mm	19mm	8mm	10mm	8mm	8mm	4mm	19mm	20mm	16mm	13mm	6mm	8mm	10mm	5mm	2mm
Max. rpm	34,000	33,000	80,000	68,000	100,000	100,000	100,000	45,000	45,000	60,000	60,000	100,000	38,000	41,000	92,000	100,000
Weight per 10	220g	100g	310g	150g	20g	20g	20g	50g	40g	30g	30g	20g	70g	40g	20g	20g
Price/1 TB	KEN-250-0410K	KEN-250-0420K	KEN-250-0430K	KEN-250-0440K	KEN-250-0450K	KEN-250-0460K	KEN-250-0470K	KEN-250-0510K	KEN-250-0520K	KEN-250-0530K	KEN-250-0540K	KEN-250-0550K	KEN-250-0610K	KEN-250-0620K	KEN-250-0630K	KEN-250-0640K
	46.00	48.00	36.00	46.00	48.00	36.00	40.00	40.00	51.00	46.00	36.00	38.00	44.00	43.00	38.00	36.00

Shape	B65	B70	B71	B73	B81	B82	B83	B84	B91	B92	B93	B95	B96	B97	B101
Grade	RA120	RA120	RA120	RA120	RA120	RA120	RA120	RA120	RA120	RA120	RA120	RA120	RA100	RA100	RA100
Diameter	3mm	19mm	16mm	13mm	19mm	13mm	10mm	8mm	13mm	6mm	5mm	3mm	3mm	3mm	16mm
Length	3mm	3mm	2.4mm	3mm	5mm	5mm	5mm	5mm	16mm	6mm	5mm	5mm	6mm	10mm	18mm
Max. rpm	100,000	50,000	60,000	73,000	50,000	76,000	87,000	100,000	34,000	81,000	100,000	100,000	100,000	100,000	33,000
Weight per 10	20g	40g	40g	25g	40g	30g	30g	20g	50g	20g	20g	20g	20g	20g	70g
Price/1 TB	KEN-250-0650K	KEN-250-0700K	KEN-250-0710K	KEN-250-0730K	KEN-250-0810K	KEN-250-0820K	KEN-250-0830K	KEN-250-0840K	KEN-250-0910K	KEN-250-0920K	KEN-250-0930K	KEN-250-0950K	KEN-250-0960K	KEN-250-0970K	KEN-250-1010K
	36.00	46.00	41.00	51.00	38.00	34.00	40.00	40.00	36.00	40.00	40.00	40.00	46.00	53.00	53.00

Shape	B102	B103	B104	B105	B106	B111	B112	B113	B114	B115	B121	B122	B123	B124	B131	B132	B135
Grade	RA180	RA80	RA100	RA120	RA100	RA100	RA120	RA80	RA80	RA100	RA120	RA120	RA80	RA120	RA80	RA80	RA120
Diameter	16mm	16mm	8mm	6mm	3mm	12mm	10mm	6mm	6mm	2.5mm	13mm	10mm	5mm	3mm	13mm	10mm	6mm
Length	13mm	5mm	10mm	6mm	3mm	18mm	13mm	6mm	10mm	3mm	13mm	10mm	5mm	3mm	13mm	13mm	13mm
Max. rpm	44,000	61,000	68,000	100,000	100,000	33,000	45,000	70,000	68,000	100,000	45,000	61,000	100,000	100,000	34,000	45,000	60,000
Weight per 10	60g	40g	20g	20g	20g	50g	40g	30g	20g	20g	50g	40g	20g	20g	50g	50g	30g
Price/1 TB	KEN-250-1020K	KEN-250-1030K	KEN-250-1040K	KEN-250-1050K	KEN-250-1060K	KEN-250-1110K	KEN-250-1120K	KEN-250-1130K	KEN-250-1140K	KEN-250-1150K	KEN-250-1210K	KEN-250-1220K	KEN-250-1230K	KEN-250-1240K	KEN-250-1310K	KEN-250-1320K	KEN-250-1350K
	45.00	36.00	38.00	38.00	38.00	41.00	52.00	45.00	62.00	46.00	41.00	51.00	40.00	38.00	41.00	51.00	40.00



'W' Shape Shank Dia. 3mm

Shape	W142	W143	W144	W145	W146	W147	W149	W151	W152	W153	W154	W158	W159	W160	W162	W163
Grade	RA120	RA120	RA100	RA80	RA80	RA120	RA120	RA120	RA100	A120	RA80	RA120	RA100	RA80	RA80	RA80
Diameter	2.5mm	3mm	3mm	3mm	3mm	4mm	4mm	5mm	5mm	5mm	5mm	6mm	6mm	6mm	6mm	6mm
Length	6mm	3mm	6mm	10mm	13mm	0.8mm	6mm	3mm	6mm	10mm	13mm	3mm	5mm	6mm	10mm	13mm
Max. rpm	100,000	100,000	100,000	100,000	100,000	100,000	100,000	100,000	100,000	80,000	70,000	90,000	92,000	81,000	68,000	60,000
Weight per 10	20g	20g	20g	20g	20g	20g	20g	20g	20g	20g	30g	20g	20g	30g	30g	30g
Price/1 TB	46.00	36.00	38.00	46.00	46.00	34.00	34.00	34.00	34.00	38.00	38.00	36.00	38.00	36.00	38.00	34.00

'W' Shape Shank Dia. 3mm except * = 6mm

Shape	W164	W167	W170	W171*	W173	W174	W175	W176	W177*	W178*	W179*	W182	W183	W184	W185	W186*
Grade	RA80	RA60	RA60	RA60	RA80	RA60	RA60	RA60	RA60	RA60	RA60	RA60	RA80	RA80	RA60	RA60
Diameter	6mm	8mm	8mm	8mm	10mm	10mm	10mm	10mm	10mm	10mm	10mm	13mm	13mm	13mm	13mm	13mm
Length	13mm	6mm	13mm	19mm	3mm	6mm	10mm	13mm	20mm	32mm	32mm	3mm	6mm	10mm	13mm	13mm
Max. rpm	55,000	60,000	40,000	36,000	70,000	60,000	50,000	45,000	33,000	26,000	25,000	70,000	70,000	70,000	34,500	51,000
Weight per 10	40g	30g	40g	100g	30g	30g	40g	50g	120g	120g	140g	40g	40g	50g	60g	140g
Price/1 TB	41.00	41.00	51.00	44.00	41.00	41.00	44.00	52.00	53.00	42.00	46.00	46.00	46.00	52.00	38.00	45.00

'W' Shape Shank Diameter 6mm

Shape	W187	W188	W192	W193	W194	W195	W196	W197	W200	W201	W202	W203	W204	W205	W208
Grade	RA60	RA60	RA80	RA60	RA60	RA60	RA60	RA60	RA80	RA60	RA60	RA60	RA60	RA60	RA46
Diameter	13mm	13mm	16mm	16mm	16mm	16mm	16mm	16mm	20mm	20mm	20mm	20mm	19mm	20mm	20mm
Length	25mm	38mm	6mm	10mm	13mm	19mm	25mm	50mm	3mm	6mm	10mm	13mm	19mm	25mm	50mm
Max. rpm	40,500	30,370	61,000	61,000	56,000	46,000	32,000	21,000	50,000	40,000	30,000	25,000	42,000	34,000	18,000
Weight per 10	170g	220g	140g	140g	150g	190g	220g	350g	400g	400g	160g	180g	230g	280g	500g
Price/1 TB	61.00	49.00	41.00	45.00	60.00	46.00	52.00	75.00	41.00	46.00	48.00	48.00	61.00	67.00	67.00

'W' Shape Shank Diameter 6mm except W244 = 10mm & W211 = 3mm

Shape	W211*	W212	W215	W216	W217	W218	W219	W220	W222	W225	W226	W227	W230	W236	W238	W242	W244*
Grade	RA80	RA60	RA80	RA46	RA46	RA80	RA46	RA46	RA46	RA46	RA46	RA46	RA46	RA46	RA46	RA46	RA46
Diameter	22mm	22mm	25mm	25mm	25mm	25mm	25mm	25mm	25mm	32mm	32mm	32mm	32mm	38mm	38mm	50mm	50mm
Length	3mm	6mm	3mm	6mm	10mm	13mm	19mm	25mm	50mm	6mm	9.5mm	13mm	32mm	13mm	38mm	25mm	50mm
Max. rpm	43,000	33,000	38,000	38,000	38,000	38,000	35,000	25,000	15,900	30,000	30,000	30,000	20,000	25,000	15,000	11,000	11,000
Weight per 10	60g	150g	30g	30g	40g	30g	40g	100g	730g	210g	270g	230g	700g	430g	1100g	1380g	2670g
Price/1 TB	54.00	60.00	48.00	51.00	66.00	46.00	67.00	70.00	66.00	46.00	52.00	53.00	83.00	64.00	90.00	141.00	120.00

Assorted Mounted Point Sets

Selected shapes suitable for a vast range of internal grinding operations. For use with air and electric die grinders, drills etc. 3mm and 6mm shank sizes. 'Rubelite' aluminium oxide grade for general use on metals.

Contents:

- 5 Piece:** A5, A24, A26, W217 and W205. Supplied in clear bag with header.
- 8 Piece:** A5, A24, A25, A26, A39, W177, W186 and W205. Supplied in clear bag with header.
- 24 Piece:** A5, A15, A24, A26, A32, A37, A38, B44, B52, B53, B81, B91, B97, B122, B123, B135, W144, W153, W163, W176, W177, W186, W205 and W220. Supplied in fitted wooden bench case.

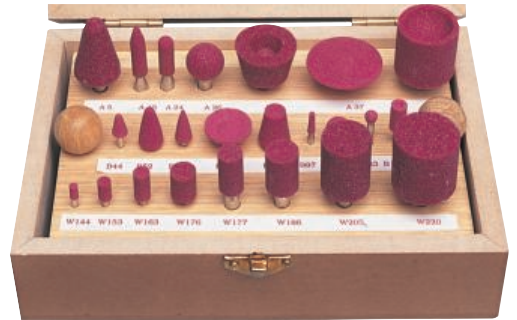

Number of Pieces	Contents	Weight each	Order Code	Price/1 TB
5	As	0.10kg	-2950K	308.00
8	Above	0.17kg	-2980K	490.00
24	Above	1.20kg	-3240K	1247.00

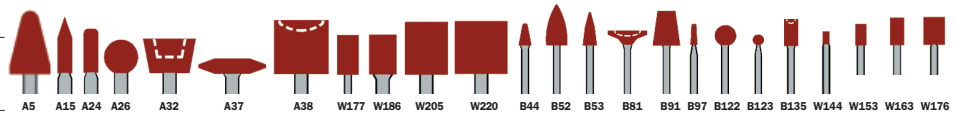

PRODUCTS ARE ONLY AVAILABLE VIA YOUR DISTRIBUTOR

ABRASIVES & POWER TOOLS



A range of tough general-purpose sharpening stones able to give keen, even cutting edges on all straight edge cutting tools. Consistent and uniform cutting edges ensure fast cutting and longer tool life.

Square Aluminium Oxide



Size (mm)	Grade	Weight each	Order Code KEN-255	Price/1 TB
100 x 6	Fine	15g	-1500K	75.00
	Medium		-1510K	75.00
	Coarse		-1520K	75.00
100 x 10	Fine	35g	-1600K	93.00
	Medium		-1610K	93.00
	Coarse		-1620K	93.00
100 x 13	Fine	55g	-1700K	124.00
	Medium		-1710K	124.00
	Coarse		-1720K	124.00

Silicon Carbide

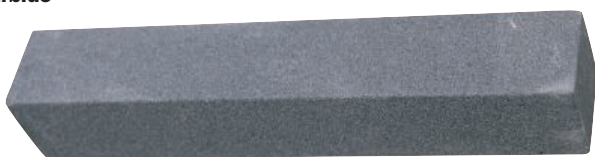

Size (mm)	Grade	Weight each	Order Code KEN-255	Price/1 TB
100 x 6	Fine	10g	-4300K	70.00
	Medium		-4310K	70.00
	Coarse		-4320K	70.00
100 x 10	Fine	30g	-4400K	89.00
	Medium		-4410K	89.00
	Coarse		-4420K	89.00
100 x 13	Fine	45g	-4500K	118.00
	Medium		-4510K	118.00
	Coarse		-4520K	118.00
150 x 13	Fine	55g	-4600K	145.00
	Medium		-4610K	145.00
	Coarse		-4620K	145.00
150 x 19	Fine	110g	-4700K	234.00
	Medium		-4710K	234.00
	Coarse		-4720K	234.00
150 x 25	Fine	170g	-4800K	377.00
	Medium		-4810K	377.00
	Coarse		-4820K	377.00

3 Square Aluminium Oxide



Size (mm)	Grade	Weight each	Order Code KEN-255	Price/1 TB
100 x 6	Fine	10g	-1800K	67.00
	Medium		-1810K	67.00
	Coarse		-1820K	67.00
100 x 10	Fine	20g	-1900K	98.00
	Medium		-1910K	98.00
	Coarse		-1920K	98.00
100 x 13	Fine	30g	-2000K	124.00
	Medium		-2010K	124.00
	Coarse		-2020K	124.00

Silicon Carbide



Size (mm)	Grade	Weight each	Order Code KEN-255	Price/1 TB
100 x 6	Fine	10g	-4900K	52.00
	Medium		-4910K	80.00
	Coarse		-4920K	82.00
100 x 10	Fine	15g	-5000K	89.00
	Medium		-5010K	89.00
	Coarse		-5020K	58.00
100 x 13	Fine	25g	-5100K	118.00
	Medium		-5110K	118.00
	Coarse		-5120K	118.00
150 x 13	Medium	40g	-5210K	234.00
150 x 19	Medium	60g	-5310K	234.00

Oilstones

A comprehensive range of bench stones and sharpening stones to cover a wide variety of sharpening and honing applications. Most of the shapes and sizes are available in fine, medium and coarse grades. Available in aluminium oxide or silicon carbide, all stones can be used wet or dry to produce sharp cutting edges or to remove burrs.

Aluminium Oxide Man-made abrasive which is extremely tough enabling high speed penetration of high tensile materials without causing excessive fracturing. This resistance to fracturing makes it a versatile material suitable for general sharpening and honing applications.

Silicon Carbide Man-made abrasive with very hard, sharp particles. This makes it ideal for non-ferrous metals, hard surfaces, alloys and cemented carbides. Also used on stone, marble, glass and plastics. A superior abrasive that is able to penetrate and cut quickly with only light pressure being applied.

Bench Stones

For workshop use. Ideal for sharpening chisels, plain iron and virtually any metallic implements.

Combination Aluminium Oxide



Size (mm)	Grade	Weight each	Order Code KEN-255	Price/1 TB
100 x 25 x 13	Med/Coarse	70g	-1050K	150.00
150 x 50 x 25	Med/Coarse	430g	-1010K	427.00
200 x 50 x 25	Med/Coarse	530g	-1030K	555.00

Single Grit Silicon Carbide



Size (mm)	Grade	Weight each	Order Code KEN-255	Price/1 TB
100 x 25 x 6	Fine	36g	-4000K	121.00
	Medium		-4010K	121.00
100 x 25 x 13	Fine	61g	-4100K	160.00
	Medium		-4110K	160.00

Single Grit Aluminium Oxide



Size (mm)	Grade	Weight each	Order Code KEN-255	Price/1 TB
100 x 25 x 13	Fine	57g	-1300K	175.00
	Medium	57g	-1310K	175.00
	Coarse	57g	-1320K	80.00
150 x 50 x 25	Fine	450g	-1100K	507.00
	Medium		-1110K	507.00
200 x 50 x 25	Fine	530g	-1200K	603.00
	Medium	570g	-1210K	603.00
	Coarse	685g	-1220K	605.00

Pocket Stone

Single Grit Aluminium Oxide

Man-made abrasive which is extremely tough, enabling high speed penetration of high tensile materials without causing excessive fracturing. This resistance to fracturing makes it a versatile material suitable for general sharpening and honing applications. Ideal for sportsmen, farmers, gardeners and the home user to bring back that sharp edge on pocket-knives, chisels etc.

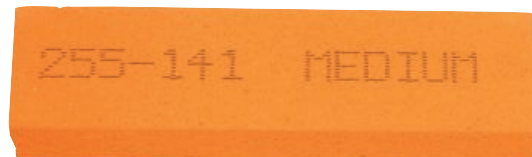

Size (mm)	Grade	Weight each	Order Code KEN-255	Price/1 TB
80 x 22 x 10	Medium	45g	-1410K	175.00



KENNEDY *Scythe Stones*
QUALITY INDUSTRIAL TOOLING

Aluminium Oxide

A general-purpose sharpening stone for agricultural and horticultural tools such as hoes, spades, edgers, clippers and shears.

Size: 235mm flat tapered and 305mm English round.



Flat tapered



Size (mm)	Grade	Weight each	Order Code KEN-255	Price/1 TB
235 x 35/15	Coarse	250g	-3620K	437.00
305 x 36/20	Coarse	610g	-3720K	463.00

Abrasive Files

Round Aluminium Oxide



Size (mm)	Grade	Weight each	Order Code KEN-255	Price/1 TB
100 x 6	Fine	10g	-2100K	131.00
	Medium		-2110K	131.00
	Coarse		-2120K	127.00
100 x 10	Fine	20g	-2200K	157.00
	Medium		-2210K	157.00
	Coarse		-2220K	157.00
100 x 13	Fine	30g	-2300K	180.00
	Medium		-2310K	180.00

Round Silicon Carbide



Size (mm)	Grade	Weight each	Order Code KEN-255	Price/1 TB
100 x 6	Fine	10g	-5400K	234.00
	Medium		-5410K	136.00
	Coarse		-5420K	139.00
100 x 10	Fine	15g	-5500K	139.00
	Medium		-5510K	139.00
	Coarse		-5520K	136.00
100 x 13	Fine	25g	-5600K	139.00
	Medium		-5610K	170.00
	Coarse		-5620K	179.00

Half Round Aluminium Oxide



Size (mm)	Grade	Weight each	Order Code KEN-255	Price/1 TB
100 x 13	Fine	25g	-2400K	190.00
	Medium		-2410K	190.00
	Coarse		-2420K	190.00

Sharpening Stone Set

Supplied in a wooden case specially selected to cover the majority of sharpening applications. All stones are 13 x 100mm medium grit supplied in both aluminium oxide and silicon carbide.

Contents:

2x square, 2x three square and 2x round.

6
PIECES



Number of Pieces	Weight each	Order Code KEN-255	Price/1 TB
6	250g	-9000K	940.00

Slip Stones

For sharpening curved edge cutting tools.

Aluminium Oxide



Size (mm)	Grade	Weight each	Order Code KEN-255	Price/1 TB
100 x 25 x 11/5	Fine	45g	-3000K	385.00
100 x 25 x 11/5	Medium	50g	-3010K	385.00
115 x 45 x 6/1.5	Medium	55g	-3110K	478.00
115 x 45 x 13/5	Fine	120g	-3200K	632.00
115 x 45 x 13/5	Medium	120g	-3210K	629.00

Silicon Carbide



Size (mm)	Grade	Weight each	Order Code KEN-255	Price/1 TB
115 x 45 x 6-1.5	Fine	40g	-5800K	445.00
	Medium		-5810K	444.00
115 x 45 x 13-5	Medium	95g	-5910K	479.00

Silversmith Stone

Aluminium Oxide



Size (mm)	Grade	Weight each	Order Code KEN-255	Price/1 TB
100 x 13 x 2	Fine	15g	-2500K	86.00
100 x 13 x 2	Medium	15g	-2510K	86.00

Knife Stone

Aluminium Oxide



Size (mm)	Grade	Weight each	Order Code KEN-255	Price/1 TB
100 x 25 x 3	Medium	20g	-2710K	231.00

Reamer Stone

Aluminium Oxide



Size (mm)	Grade	Weight each	Order Code KEN-255	Price/1 TB
125 x 25 x 5	Medium	45g	-3410K	215.00

ABRASIVES & POWER TOOLS

GROUP 258 AIR HOSE & BALANCERS

KOBE PU Air & Water Hose Reels

Auto layering mechanism to prevent jamming. Working pressure 8 bar (120 PSI). Suitable for water up to 45°C. 180° pivoting wall bracket included - can be fixed to walls or ceilings. 1/4 BSPT. Conforms to **BS EN ISO 12100: 2010**.



NEW

Hose Size Bore x Length	Order Code KBE-258	Price/1 TB
6mm x 12m	-1050K	4326.00
8mm x 12m	-1060K	4429.00
10mm x 10m	-1070K	4635.00

Rubber Air & Water Hose Reels

Designed for professional garages/workshops. Controlled slow rewind with auto layering mechanism to prevent jamming. Suitable for water up to 45°C. Working pressure 18 bar (260 PSI). 180° pivoting wall bracket included - can be fixed to walls or ceilings. 1/4 BSPT. Conforms to **BS EN ISO 12100 : 2010**.



NEW

Hose Size Bore x Length	Order Code KBE-258	Price/1 TB
10mm x 15m	-1110K	5253.00
10mm x 20m	-1120K	6129.00
10mm x 30m	-1130K	8137.00

Retractable Air Hose Balancer

With adjustable tension return, it retracts when the air tool is released, leaving the work place clear of unwanted lengths of air hose. Ideally suited for in-line production.

With spring loaded safety clip for overhead fixing.
Hose length: 1.5m.
Hose I.D.: 5mm.
Hose O.D.: 8mm.
Maximum pressure: 200psi.
Hoist range: 0 - 1.5kg.



Maximum Tool Weight	Weight each	Order Code KBE-280	Price/1 TB
1.5kg	850g	-1000K	4978.00

KENNEDY QUALITY INDUSTRIAL TOOLING

Industrial PVC Airline Hose

Reinforced with a polyester fibre braid. Used in pneumatic airline systems, crop spraying, transportation of gases and liquids, decanting of acids, salts and many other chemicals. Fully approved for food contact applications. Operating temperature range of -20°C to +60°C.

Maximum pressure ratings:

6.35mm bore - 250psi
 9.50mm bore - 150psi,
 12.7mm bore - 130psi,
 19.0mm bore - 100psi.

Supplied in 30m (100ft) reels.

Bore Size (mm)	Weight each	Order Code KEN-258	Price/1 TB
6.35 (1/4")	3.6kg	-1010K	1442.00
9.50 (3/8")	4.5kg	-1030K	1906.00
12.70 (1/2")	5.9kg	-1050K	3089.00
19.00 (3/4")	9.0kg	-1070K	3760.00



30m

Through Flow Air Hose

Open drum 20m air hose reel. Easy wind reel mechanism. With high impact resistant drum and guide walls. 1/2" air hose fitted with two ear hose clips and standard PCL couplings for 1/2" hose. 15bar working pressure. The axial supply allows the hose to be wound and unwound during operation. Supplied complete with 1.5m supply connection hose and wall mounting hooks.



20m

Group 732

Hose Length	Weight each	Order Code KEN-258	Price/1 TB
20m	4.5kg	-5100K	4119.00

Pressure Gauges

Fitted with a G1/8" brass thread, can be used to measure psi and bar readings and can be fitted directly onto any filter regulator - lubricators.

Available in two face sizes (40 and 50mm), made from tough ABS plastic. Back entry fittings.



Face Diameter	Pressure Bar	Weight each	Order Code KEN-259	Price/1 TB
40mm	0 - 12	55g	-8240K	316.00
40mm	0 - 4	50g	-8280K	316.00
50mm	0 - 12	70g	-8320K	693.00
50mm	0 - 4	70g	-8360K	693.00

KOBE Whip Hose & Adaptor

Used to supply air between air tool and supply point. Uses standard couplings. Prevents vibration damage to couplings and the user. 1/4 NPT thread. Quick release. Coupling - 650mm overall length.



0.65m



Thread	Order Code KBE-280	Price/1 TB
1/4 NPT	-1360K	488.00

Heavy Duty Nylon Air Hose

Solid brass couplings with 360° swivel and spring protectors allow use in any direction. Ideal for use in awkward access areas. Recoils to a fraction of its working length when not in use leaving the work place clear of entanglement hazards.

Extended length: 7.5m.

Pressure rating:

8.0mm diameter - 250psi.
 9.5mm diameter - 150psi.

7.5m



Thread (BSPT)	Outside Diameter	Weight each	Order Code KBE-280	Price/1 TB
1/4"	6.0mm	850g	-1140K	380.00
3/8"	9.5mm	850g	-1300K	1299.00

Industrial PVC Airline Hose

Hi-flex Polyurethane Air Hose With brass 360° swivel couplings, ideal for use in awkward access areas. Recoils to a fraction of its working length leaving the work place clear of entanglement hazards.

Extended length: 7.5m.

Pressure rating:

6.0mm diameter - 200psi
 9.5mm diameter - 300psi.

7.5m

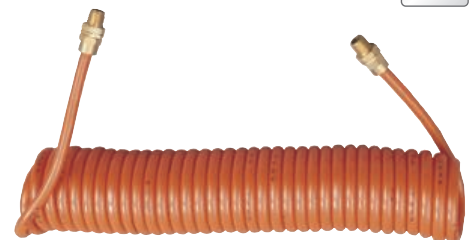

Thread (BSPT)	Outside Diameter	Weight each	Order Code KBE-280	Price/1 TB
1/4"	8.0mm	850g	-1160K	1299.00
3/8"	9.5mm	850g	-1320K	1516.00

ABRASIVES & POWER TOOLS



KENNEDY *Air Filter Regulator Lubricator*
QUALITY INDUSTRIAL TOOLING

Manual/semi-auto drain as standard. Rolling membrane regulator with secondary bleed and adjustable knob. 20µm element as standard. Constant oil flow. Fully assembled units comprise a combined filter - regulator - lubricator in modular configuration.

Body: technopolymer.
Bowl: polycarbonate with protector.
Filtration size: 20µm.

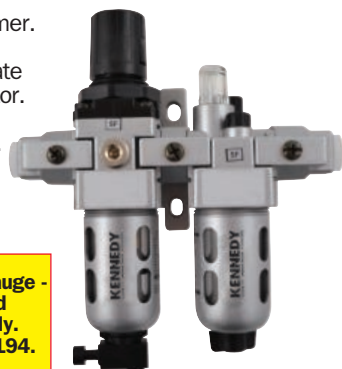

Pressure Gauge - supplied separately. See page 194.

Port Size	Flow Rate	Order Code KEN-259	Price/1 TB
G ¹ / ₄	260ltr/min	-5830K	6913.00
G ³ / ₈	1100ltr/min	-5840K	9299.00
G ¹ / ₂	2500ltr/min	-5850K	11311.00

Air Filter Regulator Combi

Manual/semi-auto drain as standard. Rolling membrane regulator with secondary bleed and adjustable knob. 20µm element as standard. Simply unscrew bowl for servicing. Use individually or as part of a combination unit.

Pressure range: 0 - 8bar.
Max inlet: 15bar.
Body: Technopolymer.
Bowl: Polycarbonate with protector.
Filtration size: 20µm.



Port Size	Flow Rate	Order Code KEN-259	Price/1 TB
G ¹ / ₄	800ltr/min	-5800K	6503.00
G ³ / ₈	1650ltr/min	-5810K	7103.00
G ¹ / ₂	3000ltr/min	-5820K	7759.00

Air Lubricator Units

Adjustable, constant oil flow. Integral mounting provision. Use individually or as part of a combination unit.

Temperature range: -10°C to 60°C.
Max input pressure: 10bar.
Body: Technopolymer.
Bowl: Polycarbonate with protector.
Recommended oil: ISO VG32 (Servo System 32).
Filtration size: 20µm.



Port Size	Bowl Capacity	Order Code KEN-259	Price/1 TB
G ¹ / ₄	28.0cc	-5900K	1886.00
G ³ / ₈	46.0cc	-5910K	2201.00
G ¹ / ₂	89.5cc	-5920K	3269.00

Portable Air Preparation Cradle

Combined Filter-Regulator-Lubricator modular unit. Housed in a rugged stove enamelled steel cage. Manual filter drain. Push to lock non-rising regulator control knob. Constant lubricator oil flow & very low pick-up pressure. Rugged metal bowl guards. Available 1/2" providing 3000l/min (106cfm) at 7bar. Filters out condensate build-up from compressor through mains close to point of use. Lubricates near to air tools. Prolongs life of air tools. Accessibility of air to work location. High flow rate allows multiple air tool use. Adjustable pressure range 0.5 to 10bar. For use in garages (very high automotive use), machine shops, joinery industry, sheet metal industry and any industry where air tools or spray guns are used.



Size	Delivery (@7bar)	Order Code KEN-294	Price/1 TB
1/2"	3000l/min(106cfm)	-3001B	14419.00

Air Filter Units

Manual/Semi-Auto drain as standard, 20µm element, simply unscrew bowl for servicing. Integral mounting provision. Use individually or as part of a combination unit.

Pressure range: 0 - 8bar max Inlet: 15bar.
Temperature range: -10°C to 60°C.
Filtration standard: 25µm.
Body: Technopolymer
Bowl: Polycarbonate with protector.
Filtration size: 20µm.



Port Size	Flow Rate	Order Code KEN-259	Price/1 TB
G ¹ / ₄	800ltr/min	-5500K	1508.00
G ³ / ₈	1900ltr/min	-5510K	2075.00
G ¹ / ₂	3750ltr/min	-5520K	3142.00

Air Regulator Units

Rolling membrane regulator with secondary bleed and adjustable knob. Press to lock.

Pressure range: 0 - 8bar standard, 2bar, 4bar and 12bar options.
Temperature range: -10°C to 60°C.
Gauge ports: G¹/₈ (two).
Body: technopolymer.



Port Size	Flow Rate	Order Code KEN-259	Price/1 TB
G ¹ / ₄	600ltr/min	-6100K	1384.00
G ³ / ₈	2050ltr/min	-6110K	2685.00
G ¹ / ₂	3200ltr/min	-6120K	3844.00

Electronic Auto Drain Valve

Electronic timer for ultimate reliability. Adjustable interval and discharge times. Self cleaning valve needs no maintenance. LED indicators show operational status. Impulse test button. Supplied with full instructions. Includes tamperproof kit.

Electronic Timer:
Power 'ON' LED. Valve 'OPEN' LED.
Interval time: 0.5 to 45min.
Discharge time: 0.5 to 10sec.
Solenoid Valve: 0 to 16bar.
Function: 2/2 NC.
Port connections: G³/₈.
Main pressure range: 0 - 16bar max.
Filtration: strainer recommended.
Temperature range: Ambient -10°C to +50°C, Media -10°C to +140°C.
Lubrication: not required.
Media: air, gases, non-corrosive liquids.

Timer & Solenoid Valve Assembly:
Electrical data: AC 220V, 50Hz, 19W AC 110V, 50Hz, 28W.
Insulation: Class H 180°C.
Protection: IP65 (with connector).
Temperature range: -10°C to +140°C.

Materials Solenoid Valve:
Tube and plunger: stainless steel.
Spring: stainless steel.
Body: brass.
Seals: Buna.



Model Number	Size	Order Code KEN-259	Price/1 TB
AVD220	220V	-6200K	7957.00

KOBE Mini Oiler

Feeds oil directly into the airline ensuring your air tool is well lubricated at all times preventing corrosion. The clear body reservoir allows immediate inspection of the oil level.



All brass construction.

Thread Size	Weight each	Order Code KBE-280	Price/1 TB
G ¹ / ₄ "	130g	-1400K	488.00

Water Separator

Continuously removes moisture from the air supply helping to prevent corrosion to the internal components of the air tool. The spring valve allows immediate draining of reservoir without any down time.



Thread Size	Weight each	Order Code KBE-280	Price/1 TB
G ¹ / ₄ "	110g	-1900K	596.00

ABRASIVES & POWER TOOLS

KOBE 'Standard' Couplings



The 'Industry Standard' coupling. Zinc plated all steel construction, finished in hard wearing passivate. Positive single locking action prevents accidental dislocation. For fixed applications - for couplings for trailing hoses see 'Vertex' type below. Compatible with the range of standard Kobe adaptors. Free air flow rate at 7bar/100psi: **35 to 42cfm** (990 to 1130ltr/min).

Female Threaded

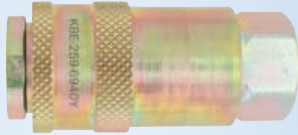

Type	Thread Size	Order Code	Price/1 TB
Standard	G ^{1/4} "	-6940Y	313.00
	G ^{3/8} "	-6946F	324.00

Male Threaded

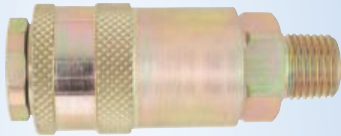

Type	Thread Size	Order Code	Price/1 TB
Standard	G ^{1/4} "	-6944D	313.00

'Vertex' Couplings

With slim profile, double locking action and additional collar to prohibit dirt ingress. Designed for trailing hoses.

Male Threaded

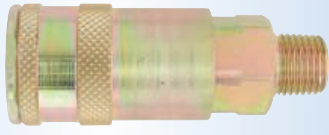

Type	Thread Size	Order Code	Price/1 TB
Vertex	G ^{1/4} "	-6983A	324.00

Coupling Adaptors

Designed for use with Kobe airline couplings. 'Third level' zinc plated for protection against corrosion.

Female Threaded

For connecting a **Standard, Vertex** or **Safeflow** coupling to a male threaded fitting.



Type	Thread Size	Order Code	Price/1 TB
Female	G ^{1/4} "	-6992X	94.00

Male Threaded

For connecting a **Standard, Vertex** or **Safeflow** coupling to a female threaded fitting.

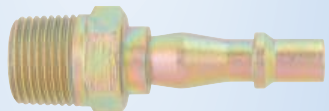

Type	Thread Size	Order Code	Price/1 TB
Male	G ^{3/8} "	-6996D	110.00

Integral Tailpiece

For connecting a **Standard, Vertex** or **Safeflow** coupling to a hose.



Type	Bore Size	Order Code	Price/1 TB
Tailpiece	1/4"	-6983P	94.00
	3/8"	-6984T	94.00

PCL 'Standard' Couplings

Female Threaded

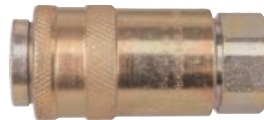

Product Number	Thread Size	Order Code	Price/1 TB
AC21CF02	G ^{1/4} "	-1940Y	416.00
AC21EF	G ^{3/8} "	-1946F	624.00
AC21JF	G ^{1/2} "	-1946R	624.00

Male Threaded

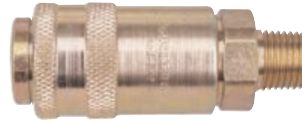

Product Number	Thread Size	Order Code	Price/1 TB
AC21CM	G ^{1/4} "	-1944D	394.00
AC21EM	G ^{3/8} "	-1946K	624.00
AC21JM	G ^{1/2} "	-1946W	624.00

Integral Tailpiece



Product Number	Thread Size	Order Code	Price/1 TB
AC21T02	G ^{3/8} "	-1948D	624.00

'Vertex' Couplings

Male Threaded

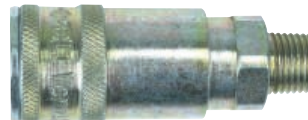

Product Number	Thread Size	Order Code	Price/1 TB
AC91CM	G ^{1/4} "	-1983D	525.00

Female Threaded



Product Number	Thread Size	Order Code	Price/1 TB
AC91CF	G ^{1/4} "	-1983A	525.00

Coupling Adaptors

Female Threaded



Product Number	Thread Size	Order Code	Price/1 TB
ACA2746	G ^{1/4} "	-1992X	111.00
ACA6582	G ^{3/8} "	-1996B	165.00

Male Threaded



Product Number	Thread Size	Order Code	Price/1 TB
ACA2746	G ^{1/4} "	-1985R	111.00
ACA6582	G ^{3/8} "	-1996D	394.00

Integral Tailpiece



Product Number	Bore Size	Order Code	Price/1 TB
ACA1793	1/4"	-1983P	111.00
ACA2487	5/16"	-1984Q	79.00
ACA2488	3/8"	-1984T	111.00

'SafeFlow' Couplings

Safe and simple to use. Enhances workshop safety - prevents hose whip. Creates a safe compressed air environment. Two stage self-venting release. Hard wearing steel construction with corrosive resistant finish. Conforms to **ISO 4414:1998** and **EN 983:1996**. Genuine PCL product, designed and manufactured in Sheffield, England. **Compatible with standard adaptors.**

Female Threaded

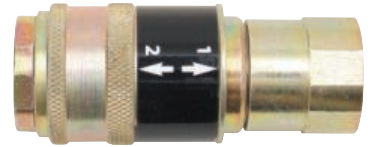

Product Number	Thread Size	Order Code	Price/1 TB
SC21CF	G ^{1/4} "	-4518T	670.00
SC21EF	G ^{3/8} "	-4521B	778.00
SC21JF	G ^{1/2} "	-4523D	778.00

Male Threaded



Product Number	Thread Size	Order Code	Price/1 TB
SC21CM	G ^{1/4} "	-4520A	670.00
SC21JM	G ^{1/2} "	-4524E	778.00

Integral Tailpiece



Product Number	Bore Size	Order Code	Price/1 TB
SC21R	1/4"	-4528M	778.00

Twin Coupling Assembly

A quick and easy solution to providing two operation points from a single air line. Fits directly into any single **Standard, Vertex** or **Safeflow** coupling. **Overall length: 180mm.**



Product Number	Coupling Style	Order Code	Price/1 TB
AC6103	Standard	-1981A	1845.00
AC6503	Vertex	-1981L	1575.00



GROUP 291

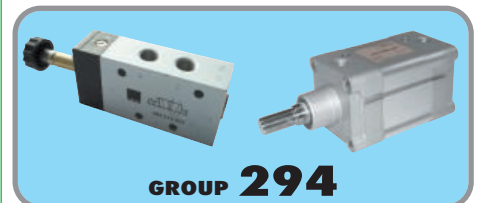

GROUP 294

PCL '60 Series' Couplings

Designed for general industrial applications - free flow air rate at 7bar/100psi: **55 to 60cfm** (1557 to 1698ltr/min). All steel construction with hard wearing passivate finish. Hardened steel shoulder to prevent accidental disconnection in use.

Female Threaded

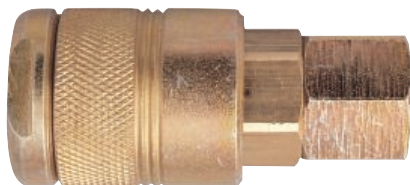

Product Number	Thread Size	Order Code PCL-259	Price/1 TB
AC4CF	G ¹ / ₄ "	-1980L	1339.00
AC4EF	G ³ / ₈ "	-1958T	1317.00

Male Threaded

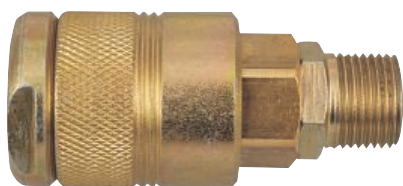

Product Number	Thread Size	Order Code PCL-259	Price/1 TB
AC4EM	G ³ / ₈ "	-1959V	1339.00
AC4JM	G ¹ / ₂ "	-1960B	1339.00

60 Series Coupling Adaptors

Case hardened with hard wearing passivate finish for use with '60 Series' couplings.

Female Threaded

For connecting a 60 Series coupling to a male threaded fitting.

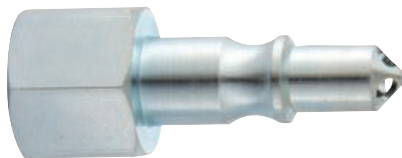

Product Number	Thread Size	Order Code PCL-259	Price/1 TB
ACA2653	G ¹ / ₄ "	-1986D	284.00

Male Threaded

For connecting a 60 Series coupling to a female threaded fitting.



Product Number	Thread Size	Order Code PCL-259	Price/1 TB
ACA2657	G ¹ / ₄ "	-1986M	366.00
ACA2661	G ³ / ₈ "	-1988T	398.00

Integral Tailpiece

For connecting a 60 Series coupling to a hose.



Product Number	Thread Size	Order Code PCL-259	Price/1 TB
ACA2658	G ¹ / ₄ "	-1986P	398.00
ACA2659	G ³ / ₈ "	-1986R	398.00

'100 Series' Couplings (Hi-Duty)

Large diameter allows greater airflow making them suitable for industrial applications - free air flow rate at 7bar/100psi: **100 to 120cfm** (2830 to 3400ltr/min). All steel construction with hardened shoulder protects against accidental disconnection. Hard wearing passivated zinc finish.

Female Threaded

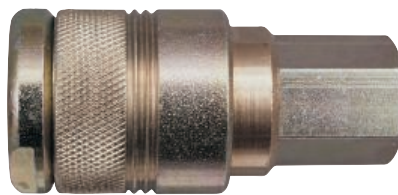

Product Number	Thread Size	Order Code PCL-259	Price/1 TB
AC5EF	G ³ / ₈ "	-1980N	1640.00
AC5JF	G ¹ / ₂ "	-1980T	1640.00

Male Threaded

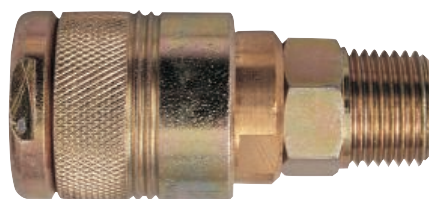

Product Number	Thread Size	Order Code PCL-259	Price/1 TB
AC5EM	G ³ / ₈ "	-1980Q	1640.00
AC5JM	G ¹ / ₂ "	-1980X	1640.00

100 Series Coupling Adaptors

Case hardened with hard wearing passivate finish. For use with '100 Series' type couplings.

Female Threaded

For connecting a 100 series coupling to a male threaded fitting.



Product Number	Thread Size	Order Code PCL-259	Price/1 TB
ACA2994	G ³ / ₈ "	-1994M	394.00

Male Threaded

For connecting a 100 series coupling to a female threaded fitting.

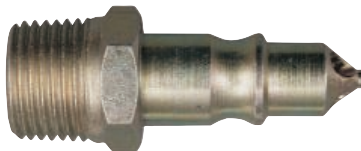

Product Number	Thread Size	Order Code PCL-259	Price/1 TB
ACA2999	G ³ / ₈ "	-1994W	394.00
ACA3035	G ¹ / ₂ "	-1995G	394.00

Integral Tailpiece

For connecting a 100 series coupling to a hose.



Product Number	Hose Size	Order Code PCL-259	Price/1 TB
ACA3036	1/2" Bore	-1995J	394.00
ACA3037	3/8" Bore	-1995L	394.00

AIRLINE FITTINGS

KOBE XF Series Couplings



Euro 130

Offering increased airflow and enhanced tool efficiency. Heavy duty steel construction with corrosive resistant finish. Free air flow rate at 7bar/100psi: -**130cfm**. Steel shoulder prevents accidental disconnection. Compatible with Euro adaptor styles CEJN320, RECTUS 25 and 26 series.

Nominal bore: 7.4mm.

Flow rate @6bar: 2200l/min @0.5bar p.d.

Max. working pressure: 35 bar. (508lbf/in.).

Temperature range: -40°C to 100°C.

Female Threaded



Type	Thread Size	Order Code KBE-259	Price/1 TB
Euro 130	G ¹ / ₄ "	-6981H	384.00

XF Series (Euro 130) Adaptors Male Threaded

For connecting an XF series coupling to a female threaded fitting.



Type	Thread Size	Order Code KBE-259	Price/1 TB
Standard	G ¹ / ₄ "	-6102A	81.00

PCL XF Series (Euro 130) Couplings

Female Threaded



Product Number	Thread Size	Order Code PCL-259	Price/1 TB
AC71CF	G ¹ / ₄ "	-1981H	978.00
AC71EF	G ³ / ₈ "	-1981M	1144.00
AC71JF	G ¹ / ₂ "	-1981T	1144.00

Male Threaded



Product Number	Thread Size	Order Code PCL-259	Price/1 TB
AC71CM	G ¹ / ₄ "	-1981K	978.00
AC71EM	G ³ / ₈ "	-1981P	1144.00
AC71JM	G ¹ / ₂ "	-1981W	1144.00

XF Series (Euro 130) Adaptors Female Threaded



Product Number	Thread Size	Order Code PCL-259	Price/1 TB
AA7102	G ¹ / ₄ "	-1102A	193.00
AA7103	G ³ / ₈ "	-1103C	258.00
AA7104	G ¹ / ₂ "	-1104E	361.00

Male Threaded



Product Number	Thread Size	Order Code PCL-259	Price/1 TB
AA7106	G ¹ / ₄ "	-1106K	202.00
AA7107	G ³ / ₈ "	-1107M	202.00
AA7108	G ¹ / ₂ "	-1108P	361.00

Integral Tailpiece



Product Number	Bore Size	Order Code PCL-259	Price/1 TB
AA7110	1/4"	-1110R	193.00
AA7112	3/8"	-1112B	183.00
AA7113	1/2"	-1113C	201.00

KOBE 'Schrader' Couplings



High flow, quick release couplings with locking facility to prevent accidental disconnection. Corrosive resistant finish. Free air flow rate at 7bar/100psi: **50cfm (1400ltr/min)**.

Female Threaded

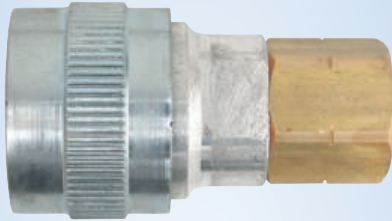

Thread Size	Thread Type	Order Code	Price/1 TB
G ^{1/4} "	Female	-7002A	410.00

'Schrader' Coupling Adaptors

Corrosive resistant finish. For use with Schrader airline couplings.

Female Threaded

For connecting a Schrader coupling to a male threaded fitting.



Thread Size	Thread Type	Order Code	Price/1 TB
G ^{1/4} "	Female	-6998J	110.00

Male Threaded

For connecting a Schrader coupling to a female threaded fitting.



Thread Size	Thread Type	Order Code	Price/1 TB
G ^{1/4} "	Male	-6998G	94.00

Integral Tailpiece

For connecting a Schrader coupling to a hose.



Bore Size	Thread Type	Order Code	Price/1 TB
1/4"	Tailpiece	-6998A	94.00

PCL PF Series Adaptor

A competitive alternative to the genuine Schrader. With a corrosive resistant finish and case hardened for longer life.

Male Threaded

For connecting a Schrader coupling to a female threaded fitting.



Product Number	Thread Size	Order Code	Price/1 TB
AA7702	1/4" BSPT	-1702B	201.00

PCL Genuine 'Schrader' Couplings

High flow, quick release couplings with locking facility to prevent accidental disconnection. Corrosive resistant finish. Free air flow rate at 7bar/100psi: **50cfm (1400ltr/min)**.

Female Threaded

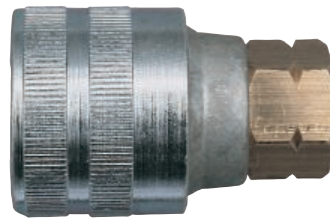

Thread Size	Overall Length	Weight each	Order Code	Price/1 TB
G ^{1/4} "	45mm	120g	-2002A	1729.00

Male Threaded

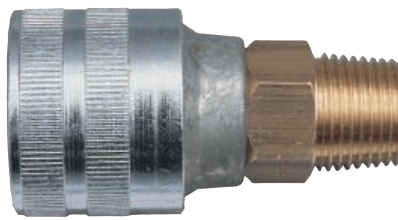

Thread Size	Overall Length	Weight each	Order Code	Price/1 TB
G ^{1/4} "	55mm	130g	-2002C	1782.00
G ^{3/8} "	60mm	135g	-2002E	1782.00

Genuine 'Schrader' Coupling Adaptors

Case hardened, zinc finish. For use with 'Schrader' type couplings.

Female Threaded

For connecting a Schrader coupling to a male threaded fitting.



Thread Size	Overall Length	Weight each	Order Code	Price/1 TB
G ^{1/4} "	46mm	25g	-1998J	349.00

Male Threaded

For connecting a Schrader coupling to a female threaded fitting.



Thread Size	Overall Length	Weight each	Order Code	Price/1 TB
G ^{1/4} "	46mm	35g	-1998G	349.00

Integral Tailpiece

For connecting a Schrader coupling to a hose.



Bore Size	Overall Length	Weight each	Order Code	Price/1 TB
1/4"	65mm	10g	-1998A	349.00
5/16"	60mm	25g	-1998E	349.00
3/8"	60mm	25g	-1998C	349.00

Genuine 'Schrader' Heavy Duty Couplings

High flow, quick release couplings with locking facility to prevent accidental disconnection. Swivel facility eliminates hose kinking. Free air flow rate at 7bar/100psi: **110cfm (3080ltr/min)**.

Female Threaded

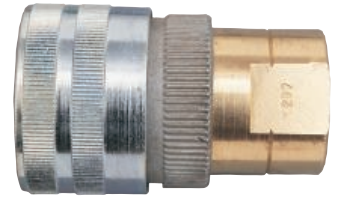

Thread Size	Overall Length	Weight each	Order Code	Price/1 TB
G ^{1/4} "	60mm	750g	-2003F	3191.00

Genuine 'Schrader' Heavy Duty Coupling Adaptors

Case hardened, zinc finish. For use with 'Schrader' Type Heavy Duty couplings.

Male Threaded

For connecting a Schrader Heavy Duty coupling to a female threaded fitting.



Thread Size	Overall Length	Weight each	Order Code	Price/1 TB
G ^{1/2} "	55mm	85g	-1999W	510.00

Integral Tailpiece

For connecting a Schrader Heavy Duty coupling to a hose.



Bore Size	Overall Length	Weight each	Order Code	Price/1 TB
3/8"	72mm	45g	-1999R	510.00
1/2"	72mm	65g	-1999T	510.00

InstantAir Couplings & Adaptors

Original and genuine Broomwade bayonet fittings. Steel bayonet, preventing accidental disconnection. Suitable for most fixed compressed air applications, although swivel adaptors are recommended for hose applications.

Nominal bore: 5.6mm.
Maximum flow rate: 54cfm @100lbf/in.
Maximum working pressure: 17bar (250lbf/in.).
Temperature range: -20°C to 80°C.

InstantAir Couplings



Product Number	Thread Size	Order Code	Price/1 TB
AA5106	G ^{1/4} " Female	-1006M	411.00
AA5102	G ^{1/4} " Male	-1002H	411.00

InstantAir Adaptors Female Threaded



Product Number	Thread Size	Order Code	Price/1 TB
AC51CF	G ^{1/4} "	-1980Z	720.00

KENNEDY *Ball Valves*
QUALITY INDUSTRIAL TOOLING



Pressure range: 0 to +10bar.
Temperature range: -25 to +90°C.
Female to Male

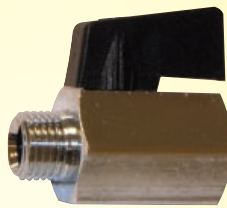

Product Number	Thread Size	Order Code KEN-259	Price/1 TB
VAB1FM	G ¹ / ₈ - G ¹ / ₈	-7200K	411.00
VAB2FM	G ¹ / ₄ - G ¹ / ₄	-7210K	411.00
VAB3FM	G ³ / ₈ - G ³ / ₈	-7220K	411.00
VAB4FM	G ¹ / ₂ - G ¹ / ₂	-7230K	552.00

Female to Female



Product Number	Thread Size	Order Code KEN-259	Price/1 TB
VB2FF	G ¹ / ₄ - G ¹ / ₄	-7310K	411.00
VB3FF	G ³ / ₈ - G ³ / ₈	-7320K	411.00
VB6FF	G ³ / ₄ - G ³ / ₄	-7340K	821.00

NPT-BSP Adaptors

Specially designed to allow British Standard airline couplings and adaptors to be fitted to 1/4" NPT threaded air tools. Also suitable for use in hydraulic lines and coolant flow systems. Passivated zinc finish for double protection against corrosion.

Fixed



Swivel

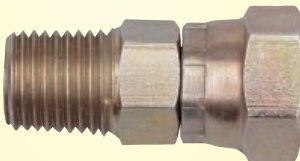

Type	BSP x NPT	Order Code KEN-259	Price/1 TB
Fixed	1/4" x 1/4"	-4900K	693.00
Swivel	1/4" x 1/4"	-4950K	285.00

PCL Flexible Elbow

Designed to eliminate hose kinks.



Product Number	Thread Size	Order Code PCL-259	Price/1 TB
FE101	1/4" BSPT	-3131B	773.00

Parallel Socket

Female to Female

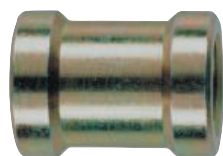

Product Number	Thread Size	Order Code PCL-259	Price/1 TB
HC6889	1/4" BSPT	-3369R	102.00

PCL Tailpieces & Connectors

Case hardened with zinc finish.

Male Threaded Tailpieces

For connecting a hose to a female threaded fitting.



Product Number	Thread Size	Bore Size	Order Code PCL-259	Price/1 TB
HC5656		1/4"	-3368N	78.00
HC1206	G ¹ / ₄ "	5/16"	-3355T	165.00
HC1217		3/8"	-3360M	73.00
HC2479		1/2"	-3362A	73.00
HC6904		1/4"	-3371T	83.00
HC2951	G ³ / ₈ "	3/8"	-3365D	78.00
HC2808		1/2"	-3364C	73.00
HC2954	G ¹ / ₂ "	1/2"	-3365H	232.00

Double-Ended Tailpieces

For joining two lengths of hose or repairing a hose.



Product Number	Bore Size	Order Code PCL-259	Price/1 TB
HC2983	1/4" x 1/4"	-3365P	110.00
HC2985	3/8" x 3/8"	-3365T	126.00
HC2986	1/2" x 1/2"	-3365W	182.00

Male Threaded Unions

For connecting female threaded fittings of the same size.

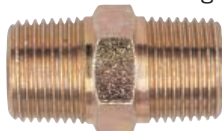

Product Number	Thread Size (G)	Order Code PCL-259	Price/1 TB
HC6560	1/4" x 1/4"	-3368X	182.00
HC4281	3/8" x 3/8"	-3366R	83.00
HC6898	1/2" x 1/2"	-3370G	137.00

Coned Tailpieces

For use in conjunction with union nuts to connect hose to male threaded fittings.



Product Number	Bore Size	Order Code PCL-259	Price/1 TB
HC5275	1/4"	-3367W	78.00
HC1225	3/8"	-3360W	73.00

Union Nuts

For use in conjunction with coned tailpieces to connect hose to male threaded fittings.



Product Number	Bore Size	Order Code PCL-259	Price/1 TB
HC5194	1/4"	-3367H	66.00
HC1226	3/8"	-3360Y	73.00

Female Threaded Y-Piece

For creating two airlines from a single supply.



Product Number	Thread Size	Order Code PCL-259	Price/1 TB
SPR4279	G ¹ / ₄ "	-4420D	318.00

AIRLINE FITTINGS

KOBE Tailpieces & Connectors



Designed for use with KOBE airline couplings. 'Third Level' Zinc plated for protection against corrosion.

Male Threaded Tailpieces

For connecting a hose to a female threaded fitting.

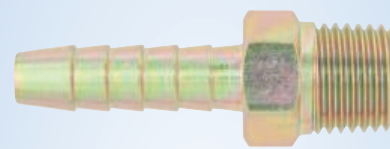

Thread Size	Bore Size	Order Code KBE-259	Price/1 TB
	1/4"	-8368N	94.00
G ¹ / ₄ "	3/8"	-8360M	94.00
	1/2"	-8362A	94.00
G ³ / ₈ "	3/8"	-8365D	94.00

Double-Ended Tailpieces

For joining two lengths of hose or repairing a hose.

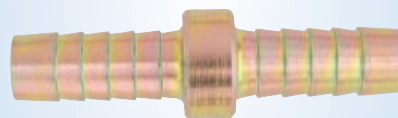

Bore Size	Order Code KBE-259	Price/1 TB
3/8" x 3/8"	-8365T	105.00

Male Threaded Unions

For connecting female threaded fittings of the same size.

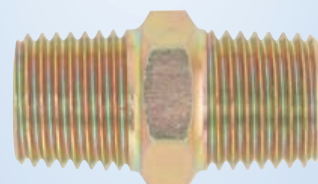

Bore Size (G)	Order Code KBE-259	Price/1 TB
1/4" x 1/4"	-8368X	73.00

Male to Female Threaded Reducing Unions

For connecting female threaded fittings to male threaded fittings of a smaller size.

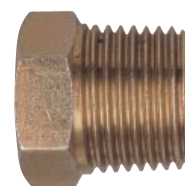

Product Number	Thread Size (G)	Order Code PCL-259	Price/1 TB
HC6895	3/8" x 1/4"	-3370A	78.00
HC6896	1/2" x 1/4"	-3370C	102.00
HC6897	1/2" x 3/8"	-3370E	110.00

Male Threaded Reducing Unions

For connecting female threaded fittings of different sizes.

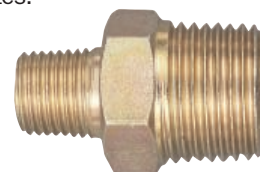

Product Number	Bore Size (G)	Order Code PCL-259	Price/1 TB
HC6899	3/8" x 1/4"	-3370K	83.00
HC6900	1/2" x 1/4"	-3370M	126.00
HC6901	1/2" x 3/8"	-3370S	192.00

ABRASIVES & POWER TOOLS

KOBE

Air Spray Guns

For Industrial and automotive use. Large responsive trigger, adjustable width of spray and flow control adjustment. Quick release bayonet fitting canisters.

Max operating pressure:
Suction/gravity: 2 - 3.5bar.
Air consumption:
Suction/gravity feed: 180 - 280ltr/min.
Pot capacities: 680cc.



Gravity Feed



Suction Feed

Type	Nozzle (mm)	Order Code KBE-259	Price/1 TB
Suction	2.0	-2150K	4775.00
Gravity	1.5	-2055K	3289.00

KOBE STAR

Suction Feed Spray Guns

Standard/Professional
 Well balanced with large, responsive triggers, and adjustable width of spray. For horizontal or vertical use with cellulose enamel or acrylic paints etc. Both with 1/4" NPT male fittings. 30 - 70psi, 7 - 12cfm. Standard model is suitable for applying base coats. Professional is suitable for applying finishing coats.

Weight: 1.3kg.



Nozzle (mm)	Max.Spray Pattern	Order Code STA-259	Price/1 TB
Standard			
1.4	240mm	-1000A	3605.00
1.8	280mm	-1010B	3500.00
Professional			
1.5	255mm	-1200D	4350.00
2.0	265mm	-1210E	4750.00

Spare Needles



Feed Type	Size (mm)	Weight each	Order Code STA-259	Price/1 TB
Gravity	1.4	10g	-2120M	350.00
	1.4	15g	-2100K	275.00
Suction	1.8	16g	-2110L	299.00
	1.5	15g	-2130N	375.00
Suction	2.0	15g	-2140P	450.00

Spare Air Caps



Feed Type	Size (mm)	Weight each	Order Code STA-259	Price/1 TB
Gravity	1.5	50g	-2020H	1450.00
Suction	1.4 & 1.8	100g	-2000F	1250.00
	1.4	50g	-2010G	1350.00
Suction	2.0	50g	-2030J	1500.00

Gravity Feed Spray Gun

Professional

Well balanced with large, responsive trigger and adjustable width of spray. For horizontal or vertical use with cellulose enamel or acrylic paints etc. With 1/4" NPT male fittings. 40 - 60psi, 6 - 12cfm. Screw top.

Weight: 1.10kg.



Nozzle (mm)	Max. Spray Pattern	Order Code STA-259	Price/1 TB
1.4	195mm	-1100C	4250.00
Spare Filter for STA259-1100C			-2060S 99.00

Spray Gun Accessories

Spare Nozzles



Feed Type	Size (mm)	Weight each	Order Code STA-259	Price/1 TB
Gravity	1.4	35g	-2220S	850.00
Suction	1.4	30g	-2200Q	550.00
	1.8	30g	-2210R	650.00
Suction	1.5	25g	-2230N	950.00
	2.0	25g	-2240P	1250.00

Repair Kit

Includes replacement air valve, valve spring, needle spring and O-rings.



Feed Type	Size (mm)	Weight each	Order Code STA-259	Price/1 TB
Gravity	1.5	14g	-2310V	475.00
Suction	1.4 & 1.8	11g	-2300T	450.00
Suction	1.5 & 2.0	15g	-2320W	499.00

KOBE STAR

Spare Pots

Only suitable with Kobe Star spray guns.



Feed Type	Weight each	Order Code STA-259	Price/1 TB
Gravity (600cc)	100g	-1500A	550.00
Suction (1000cc)	50g	-1510B	950.00
Set of No. 4 Baffles & No. 7 Cup Gaskets	10g	-2500A	150.00

TYRE INFLATORS



KENNEDY Heavy Duty Tyre Inflator with Gauge
QUALITY INDUSTRIAL TOOLING

This heavy duty push on inflator is of rugged construction and has a clearview integral pressure gauge reading from 10 - 120psi. Heavy duty corrosion resistant body with brass fittings. 300psi rated fibre reinforced rubber hose. **Conforms to EC Directive 86/217/EEC.**
Accuracy:
Reading scale: 2psi/50kPa (0.5bar).
Inflation range: 120psi/800kPa (8bar).



Model Number	Max. Pressure Reading	Weight each	Order Code	Price/1 TB
TPG170	120psi/800kPa	635g	KEN-503 -8520K	2476.00

Heavy Duty Dial Type Tyre Inflator

This push on type tyre inflator is robust and has a dial type pressure gauge reading up to a maximum of 170psi. The pressure gauge is protected from accidental damage by a rubber shock guard. Heavy duty corrosion-resistant body with steel operating lever, brass fittings and anti-shock rubber guard. 300psi rated fibre reinforced rubber hose. **Conforms to EC Directive 86/217/EEC.**



Accuracy:
Reading scale: 2psi/10kPa (0.1bar).
Inflation range: 170psi/1200kPa (12bar).

Model Number	Max. Pressure Reading	Weight each	Order Code	Price/1 TB
TPG170	170psi/1200kPa	720g	KEN-503 -8480K	2946.00

KOBE Blow Guns



Ideal for awkward and general air dusting jobs. 110mm long angled nozzle allowing projection of airflow directly to required area. Ergonomic design with trigger style operation. Lightweight and impact resistant nylon body with hanging point and integral air control valve. 1/4" brass BSPT inlet.
Minimum working pressure 3bar/43psi.
Safe working pressure 10bar/150psi.



Temperature Range	Weight each	Order Code	Price/1 TB
-10 to 50°C	120g	KBE-259 -5000K	437.00
-17 to 37°C	230g	-5010K	520.00

Flexible Extension

The extended flexible nozzle can be bent into any position to allow you to direct the air flow to exactly the area you require it in. Suitable for use with standard and plastic blow guns.



Overall Length	Weight each	Order Code	Price/1 TB
250mm	10g	KEN-259 -5100K	953.00

KENNEDY Blow Gun
QUALITY INDUSTRIAL TOOLING



Manufactured from bright nickel chrome plated die cast alloy for a long trouble free life. Complete with safety nozzle as standard. 1/4" NPT air inlet. Normal working pressure with safety nozzle intact is 90psi. If safety nozzle is removed a safe working pressure of 30psi is recommended.



Overall Length	Weight each	Order Code	Price/1 TB
100mm	140g	KEN-259 -5050K	253.00

Pistol Grip Blow Gun

Moulded anti-slip body made from a special acetalic resin to resist damage, staining and contamination with a 100% brass inner valve. The blow gun adjusts the airflow gradually for delicate working. With 110mm Long safety nozzle for access into awkward areas. Suitable for use with both air and water. Recommended maximum working (outlet) pressure of 2bar/30psi.



Nozzle Length	Weight each	Order Code	Price/1 TB
110mm	105g	PCL-259 -2404H	953.00

Pistol Grip Blow Gun

Manufactured from high quality die-cast alloy, giving the tool a long trouble-free life. Robust/compact design. Supplied with interchangeable conical and safety nozzles. Extensive, easy to fit, additional nozzle range.



Type	Weight each	Order Code	Price/1 TB
Blow Gun	235g	PCL-259 -2320R	1072.00
Safety Nozzle	11g	-2461H	222.00

PCL Blow Gun

Made from die cast alloy for long trouble-free life. Inlet thread 1/4" BSPT. Health and safety regulations dictate that an in-line regulator should be used to restrict pressure to 28psi.

Standard Grip
With safety nozzle.



Product Number	Weight each	Order Code	Price/1 TB
BG106	200g	PCL-259 -2106A	821.00

Plastic Blow Guns

The body is moulded from a special acetalic resin to resist damage, staining and contamination with a 100% brass inner valve. The blow gun adjusts the airflow gradually for delicate working. Also available with a 230mm extension nozzle that can be cut and bent to suit user applications. Suitable for use with both air and water. Recommended working (outlet) pressure of 2bar/30psi.

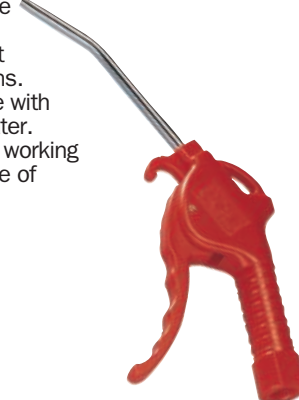

Product Number	Nozzle Length	Order Code	Price/1 TB
BG5002	110mm	PCL-259 -2402G	695.00
BG5007	230mm	-2407M	926.00

Rigid Extension Nozzle

Suitable for use with both standard and plastic blow guns.

Overall Length	Weight each	Order Code	Price/1 TB
230mm	30g	PCL-259 -2466K	567.00

ABRASIVES & POWER TOOLS

GROUP 268 MAGNETIC DRILLING

KOBE 2-speed Magnetic Drilling Machine

Suitable for industrial use, this compact 2-speed machine can drill holes up to 50mm diameter. It has powerful magnets with a clamping force of 17,000N/1,730kg/3,800lbs and comes supplied with safety guard, coolant tank, safety chain and portable case.

- Cutter capacity:** up to 50mm diameter x 50mm.
- Twist drill:** 13mm diameter x 140mm.
- Countersink:** 65mm diameter.
- Cutter arbor:** quick release arbor.
- Weldon shank:** 19mm.
- Dimensions:** 438 x 280 x 255mm.

NEW



Model Number	No Load Speed	Voltage	Weight each	Order Code KBE-268	Price/1 TB
DMM2Si	300-450	230V	15.28kg	-2828K	75000.00

4-speed Magnetic Drilling Machine

Compact and easy to use, this 4-speed variable machine is powerful enough to drill holes up to 120mm diameter. Has a clamping force of 32,000N/3,263kg/7,190lbs and is supplied with safety guard, coolant tank, safety chain and portable case. Suitable for industrial use.

- Cutter capacity:** up to 120mm diameter x 50mm.
- Twist drill capacity:** 32mm diameter x 140mm.
- Taps capacity:** up to 32mm diameter x 40mm (with adaptor).
- Weldon shank:** 19mm.
- Dimensions:** 570 x 250 x 330mm.

NEW



Model Number	No Load Speed	Voltage	Weight each	Order Code KBE-268	Price/1 TB
DMM4VSi	115-450	230V	30.0kg	-2848K	125000.00

Magnetic Drilling & Milling Machines



Suitable for light industrial use, these machines have a powerful 1200W motor providing enough power to drill holes up to 35mm diameter. They have a gravity feed coolant bottle, 13mm chuck, key and weldon adaptor, safety chain, drilling guard and hexagon keys.

- Motor:** 1200W. **Speed:** 595rpm.
- Arbor:** 19mm weldon. **Chuck size:** 13mm.
- Magnetic adhesion:** 13,000N.
- Dimensions (H x W x D):** 390 x 260 x 100mm.
- Drilling capacities:** core drill 12 - 35mm, twist drill 1.5 - 13mm, countersink 10 - 40mm.
- Cutting depth:** 50mm.
- Stroke:** 165mm.



Model Number	No Load Speed	Voltage	Weight each	Order Code KBE-268	Price/1 TB
DMM3050i	595rpm	230V	13.5kg	-4220K	27810.00

MAGTRON Two Speed Variable Milling/Drilling System



MBE40

Has a unique two speed power unit with variable speed control and a powerful magnet with a clamping force of 1,410kg/3,100lbs. Automatic safety is provided by revolutionary electronic switching system, supplied with two morse taper arbor, morse taper drift, safety chain, carabina hook, cutting oil, hexagon keys and carry case.

- Dimensions (H x W x L):** 418 x 100 x 281mm.
- Power input:** 1,050W.



Capacities (mm) Drilling	Capacities (mm) Milling	No Load Speed	Voltage	Weight each	Order Code KEN-268	Price/1 TB
3 - 23	13 - 45	280 - 640	240V	18.0kg	-7020K	131325.00

ABRASIVES & POWER TOOLS



Mini-Mag Bore & Drilling System

MB30

Has an Hitachi power unit and a powerful magnet with a clamping force of 1,000kg/ 2,200lbs. A safety relay and an automatic cut-out gives maximum operator protection. Supplied with arbor and support, safety chain, carabina hook, cutting oil, chuck and key, allen keys and carrying case. 240V.

Power input: 750W.

No load speed: 550rpm.



Dimensions (H x W x L):
295 x 100 x 235mm.

Capacities (mm)	Weight each	Order Code	Price/1 TB
Drilling Milling		KEN-268	
3 - 16 13 - 32	10.0kg	-4520K	70338.00

Variable Speed Milling/ Drilling System

MBE100

Unique power unit gives constant torque and speed regulation even under load. Powerful magnet has a clamping force of 1,410kg/ 3,100lbs. This machine has a slow start and infinite variable speed. It has a slipping clutch to protect against breakage of cutters and comes complete with an oil coolant system to automatically lubricate the cutters. Gearbox is mounted directly onto the cradle for extra rigidity. Supplied with three morse taper arbor, morse drift key, safety chain, carabina hook, hexagon keys, carry case. 240V.

Power input: 1,800W.

No load speed: 160 - 450rpm.

Dimensions (H x W x L):
500 x 135 x 312mm.



Capacities (mm)	Weight each	Order Code	Price/1 TB
Drilling Milling		KEN-268	
3 - 32 13 - 100	26.0kg	-7120K	108212.00



KENNEDY M2 Multi-Tooth Milling Cutters

Proven value and success based upon the low energy required to cut more holes accurately with extended tool life. The cutter is designed to enable a faster feed rate with lower cutting resistance, resulting in consistency of finish and tolerance.

Sizes available: 2 - 52mm diameter short and 13 - 52mm diameter long series.

Long Series

Shank diameter: 19mm^{3/4"}.

Depth of cut: 50mm.

Bore: 6mm.

Overall length: 85mm.



Diameter (mm)	Weight each	Order Code	Price/1 TB
13	80g	-2130K	1184.00
14	80g	-2140K	1184.00
15	90g	-2150K	1558.00
16	90g	-2160K	1619.00
17	100g	-2170K	1619.00
18	110g	-2180K	1619.00
19	110g	-2190K	1619.00
20	120g	-2200K	2055.00
21	130g	-2210K	2055.00
22	130g	-2220K	2179.00
23	130g	-2230K	2305.00
24	140g	-2240K	2428.00
25	150g	-2250K	2490.00
26	160g	-2260K	2553.00
27	160g	-2270K	2553.00
28	170g	-2280K	2553.00
29	180g	-2290K	2553.00
30	180g	-2300K	2553.00
31	190g	-2310K	2863.00
32	190g	-2320K	2863.00
33	210g	-2330K	2987.00
34	210g	-2340K	3112.00
35	210g	-2350K	3423.00
36	220g	-2360K	3549.00
38	260g	-2380K	3672.00
39	260g	-2390K	3859.00
40	260g	-2400K	4108.00
41	260g	-2410K	4232.00
42	260g	-2420K	4357.00
43	280g	-2430K	4600.00
44	300g	-2440K	4667.00
45	320g	-2450K	4793.00
46	280g	-2460K	4978.00
48	400g	-2480K	5103.00
50	360g	-2500K	5788.00
52	520g	-2520K	5913.00

M2 Multi-Tooth Milling Cutter Set

Short Series

Compatible with all magnetic drilling and broaching units. Complete with pilot pin and fitted case.

Shank diameter: 19mm^{3/4"}.

Bore: 6mm.

Depth of cut: 25mm.

Overall length: 60mm.

Sizes: 14, 16, 18, 20, 22 and 24mm.



Number of Pieces	Weight each	Order Code	Price/1 TB
6	800g	-3000K	7406.00

Morse Taper Adaptors

For use with Magtron broaching units, drill presses, lathes etc.

Bore diameter: 20mm.

Overall length: 156mm.



Adaptor	Weight each	Order Code	Price/1 TB
No.2 MT	0.6kg	-4120K	8448.00
No.3 MT	1.0kg	-4130K	8448.00

MAGNETIC DRILLING



Short Series

Shank diameter: 19mm^{3/4"}.

Depth of cut: 25mm.

Bore: 6mm.

Overall length: 60mm.



Diameter (mm)	Weight each	Order Code	Price/1 TB
12	70g	-1120K	966.00
13	70g	-1130K	972.00
14	70g	-1140K	1059.00
15	75g	-1150K	1059.00
16	80g	-1160K	1059.00
17	80g	-1170K	1214.00
18	85g	-1180K	1214.00
19	90g	-1190K	1221.00
20	90g	-1200K	1246.00
21	100g	-1210K	1308.00
22	100g	-1220K	1495.00
23	120g	-1230K	1619.00
24	110g	-1240K	1619.00
25	110g	-1250K	1743.00
26	120g	-1260K	1743.00
27	120g	-1270K	1743.00
28	130g	-1280K	1743.00
29	135g	-1290K	1806.00
30	140g	-1300K	1868.00
31	150g	-1310K	1993.00
32	150g	-1320K	2116.00
33	160g	-1330K	2305.00
34	160g	-1340K	2428.00
35	170g	-1350K	2739.00
36	170g	-1360K	2863.00
38	180g	-1380K	2987.00
39	185g	-1390K	3050.00
40	190g	-1400K	3112.00
42	220g	-1420K	3193.00
43	260g	-1430K	3355.00
44	220g	-1440K	3789.00
45	220g	-1450K	4108.00
50	240g	-1500K	4918.00
52	290g	-1520K	5291.00

Pilot Pins

For use with all multi-tooth milling cutters with 6mm bore. Pilots locate into pre-drilled pilot holes ensuring positional accuracy of the cutter. Suitable for 'blind' or 'through' pilot holes, pin will retract into cutter adaptor on 'bottoming'.

Short series: 77mm.

Long series: 102mm.



* For 12mm cutters only

Description	Weight each	Order Code	Price/1 TB
Short Series	15g	-4010K	342.00
Short Series*	15g	-4050K	188.00
Long Series	20g	-4020K	219.00
Long Series*	20g	-4060K	219.00

ABRASIVES & POWER TOOLS



KOBE

AIR CORDLESS ELECTRIC

KOBE

Offering high quality and superb value combined with the design elements of a modern industrial classic.

RED LINE



Industrial Quality



Classically Styled



High Quality & Superb Value

KOBE

Ergonomically designed with operator friendly features for improved comfort throughout longer periods of use.

GREEN LINE



Professional Quality

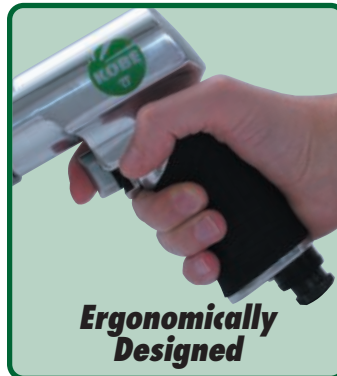

Ergonomically Designed



Packed with Features

KOBE

Higher specification offering user comfort and maximum durability - designed for continuous use..

BLUE LINE



Extra Heavy Duty



Operator Friendly Features



Highest Specification

KOBE 10mm Straight Drill



DS4510L

10mm Jacobs chuck, stall-resistant, safety lever throttle, high performance, planetary gearing, 3/8" - 24 spindle thread.

Air inlet thread: 1/4" NPT. **Chuck capacity:** 10mm.
Spindle thread: 3/8" - 24. **Minimum air hose size (ID):** 3/8" (10mm).
Air pressure: 90psi/6.3bar.
Air consumption: 4cfm* (144ltr/min).
Noise level: 88dBA.
Sound power level: 95dBA.
Vibration level: 2.5m/s².
Overall length: 206mm.



*Based on a 15 second cycle per minute average use.

Free Speed (rpm)	Weight each	Order Code KBE-270	Price/1 TB
4,500	0.90kg	-1450N	5520.00

10mm Reversible Angle Drill



DAR1510

10mm Jacobs chuck, fingertip control of reverse, reverse exhaust, overall head height 94mm, 3/8" - 24 spindle thread.

Air inlet thread: 1/4" NPT.
Chuck capacity: 10mm.
Minimum hose size: 3/8"(10mm).
Air pressure: 90psi/6.3bar.
Air consumption: 4cfm*



*Based on a 15 second cycle per minute average use.

Sound pressure level: 94dBA.
Sound power level: 106dBA.
Vibration level: 2.6m/s².
Overall length: 178mm.

Free Speed (rpm)	Weight each	Order Code KBE-270	Price/1 TB
1,500	1.80kg	-1425M	7117.00

10mm Pistol Drill



DP2210

10mm Jacobs chuck, stall resistant, heavy duty bearings, 1/2hp motor, 3/8" - 24 spindle thread.

Air inlet thread: 1/4" NPT.
Minimum air hose size (ID): 3/8" (10mm).

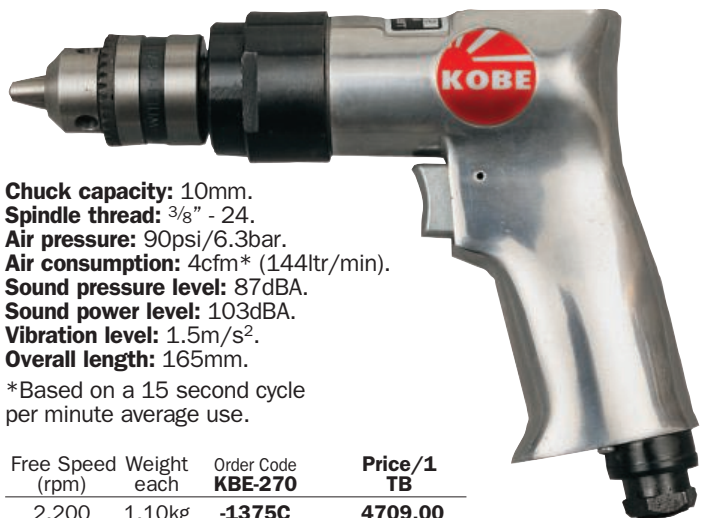

Chuck capacity: 10mm.
Spindle thread: 3/8" - 24.
Air pressure: 90psi/6.3bar.
Air consumption: 4cfm* (144ltr/min).
Sound pressure level: 87dBA.
Sound power level: 103dBA.
Vibration level: 1.5m/s².
Overall length: 165mm.

*Based on a 15 second cycle per minute average use.

Free Speed (rpm)	Weight each	Order Code KBE-270	Price/1 TB
2,200	1.10kg	-1375C	4709.00

10mm Heavy Duty Pistol Drill



DP2610

10mm Jacobs chuck, stall resistant, directional front exhaust, hammer finish casing, needle bearing gears, 3/8" - 24 spindle thread.

Air inlet thread: 1/4" NPT.
Minimum air hose size (ID): 3/8" (10mm).
Chuck capacity: 10mm.
Spindle thread: 3/8" - 24.
Air pressure: 90psi/6.3bar.
Air consumption: 4cfm* (144ltr/min).



Sound pressure level: 87dBA.
Sound power level: 103dBA.
Vibration level: 2.5m/s².
Overall length: 180mm.

*Based on a 15 second cycle per minute average use.

Free Speed (rpm)	Weight each	Order Code KBE-270	Price/1 TB
2,600	0.90kg	-1390D	8107.00

10mm Reversible Pistol Drill



DPR1810

10mm Jacobs chuck, stall resistant, heavy duty bearings, thumb switch for reverse, suitable for screwdriving.

Air inlet thread: 1/4" NPT.
Minimum air hose size (ID): 3/8" (10mm).
Spindle: 3/8" - 24.
Chuck capacity: 10mm.
Spindle thread: 3/8" - 24.



Air pressure: 90psi/6.3bar.
Air consumption: 4cfm* (144ltr/min).
Sound pressure level: 85dBA.
Sound power level: 101dBA.
Vibration level: 5.4m/s².
Overall length: 165mm.

*Based on a 15 second cycle per minute average use.

Free Speed (rpm)	Weight each	Order Code KBE-270	Price/1 TB
1,800	1.40kg	-1400L	5043.00

ABRASIVES & POWER TOOLS

GROUP 270 AIR TOOLS - DRILLS

KOBE 10mm Straight Air Drill

BCSD10 - 10mm Composite Straight Air Drill

Exhaust outlet adjusts 360° to direct air flow away from the operator. Χομπαχτ ανδ λιγητσειγητ φορ εασε οφ υσε ιν χονφινεδ αρεασ. Φαστ δριλλ βιτ χηανγε ωιτη κεψλεσσ χηυκχ ανδ α σαφετην λεσπερ τηροττλε. Εργονομιχ ανδ χουμοφορταβλε ηανδ γριπ.

Μοτορ ποωερ: 0.45ηπ.
Φρεε σπεεδ: 2,500rpm.
Χηυκχ σιζε: 10μμ.
Αιρ ινλετ τηρεαδ: 1/4" BSP.
Οπερατινγ πρεσσυρε: 90psi/6.2bar.
Minimum air hose size (ID): 3/8" (10mm).
Air consumption: 4.0cfm*.
Sound pressure level: 92dBA.
Sound power level: 110dBA.
Vibration level: 0.49m/s².
Overall length: 215mm.

NEW



*Based on a 15 second cycle per minute average use.



Keyless chuck.



Exhaust outlet adjusts 360°



Safety lever throttle



Speed adjustment.

Free Speed (rpm)	Weight each	Order Code KBE-270	Price/1 TB
2500	1.80kg	-6050K	5665.00

ABRASIVES & POWER TOOLS

KOBE 10mm Reversible Pistol Drill

FPD3175

Suitable for drilling and screwdriving. Rubber handle provides grip and operator comfort. 3/8" keyless chuck. Stall resistant. Short gear case design. Heavy duty gearing system with oil-less bushing. Spring loaded rotor vanes. Rear exhaust. Ball bearing construction for a long tool life.

Chuck capacity: 10mm.
Spindle thread: 3/8" - 24.
Air inlet thread: 1/4" NPT.
Minimum air hose size (ID): 3/8" (10mm).
Air pressure: 90psi/6.2bar.
Air consumption: 3.35cfm*.
Sound pressure level: 95dBA.
Sound power level: 100dBA.
Vibration level: 0.7m/s².
Overall length: 188mm.

*Based on a 15 second cycle per minute average use.

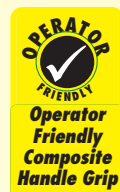
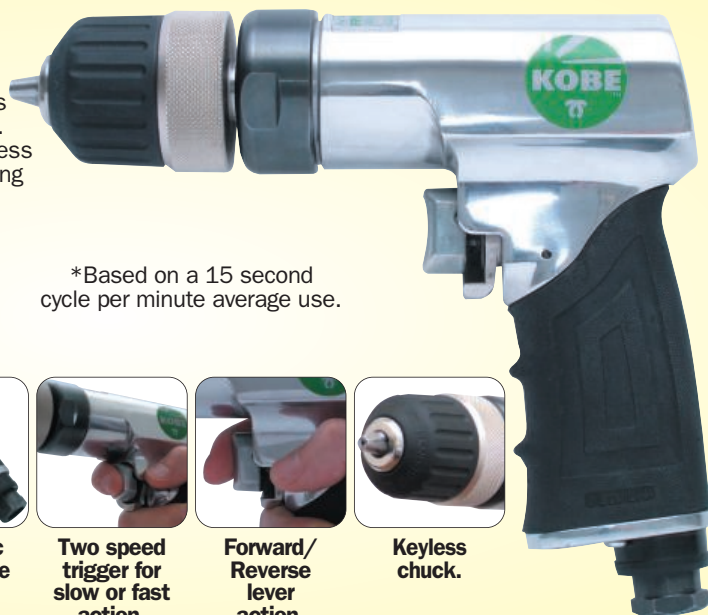

Ergonomic comfortable grip.



Two speed trigger for slow or fast action.



Forward/Reverse lever action.



Keyless chuck.

Free Speed (rpm)	Chuck size	Order Code KBE-270	Price/1 TB
1,800	3/8" (10mm)	-2152K	5520.00

KOBE 10mm Reversible Pistol Grip Drill

B2834

Use for drilling and screwdriving. Two speed trigger (slow speed when pushed halfway). Directional lever accessible from both sides for left/right handed use. 10mm (3/8") chuck included. Planetary gears for longer life and smoother running. Ergonomic comfortable grip.

Chuck size: 3/8" (10mm). **Free speed:** 1,800rpm.
Recommended air pressure: 6.2bar (90psi).
Air consumption: 4cfm* (113ltr/min).
Air inlet thread: 1/4" NPT.
Spindle thread: 3/8" - 24.
Minimum air hose size (ID): 3/8" (10mm).
Noise level†: 85dBA.
Sound power level†: 96dBA.
Vibration level #: 0.4m/s².
Overall length: 185mm.
 †Per EN ISO 15744:2002.
 #Per EN 28927-5.

*Based on a 15 second cycle per minute average use.



Ergonomic comfortable grip.



Two speed trigger for slow or fast action.



Forward/Reverse lever action.



Complete with industrial chuck.

Free Speed (rpm)	Weight each	Order Code KBE-270	Price/1 TB
1,800	1.10kg	-4310K	6630.00

KOBE 13mm Heavy Duty Pistol Drill



DP513
13mm Jacobs chuck, high reduction gearbox, high torque, with side handle, 1/2hp motor.
Air inlet thread: 1/4" NPT. **Minimum hose:** 3/8" (10mm).
Chuck capacity: 13mm. **Spindle thread:** 3/8" - 24.

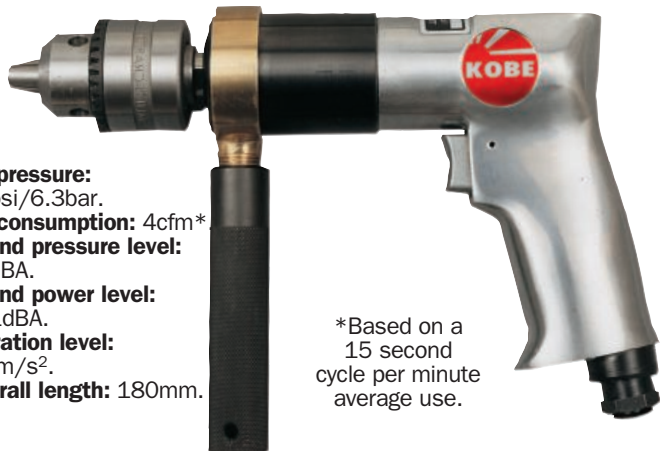

Air pressure: 90psi/6.3bar.
Air consumption: 4cfm*
Sound pressure level: 85dBA.
Sound power level: 101dBA.
Vibration level: 5.4m/s².
Overall length: 180mm.

*Based on a 15 second cycle per minute average use.

Free Speed (rpm)	Weight each	Order Code	Price/1 TB
500	1.80kg	KBE-270	7792.00

13mm Reversible Heavy Duty Pistol Drill



DPR813
13mm Jacobs chuck, thumb switch for reverse, auxiliary handle, suitable for screwdriving, heavy duty planetary gearing.
Air inlet thread: 1/4" NPT. **Minimum hose:** 3/8" (10mm).
Chuck capacity: 13mm. **Spindle thread:** 3/8" - 24.
Air pressure: 90psi/6.3bar. **Air consumption:** 4cfm*.

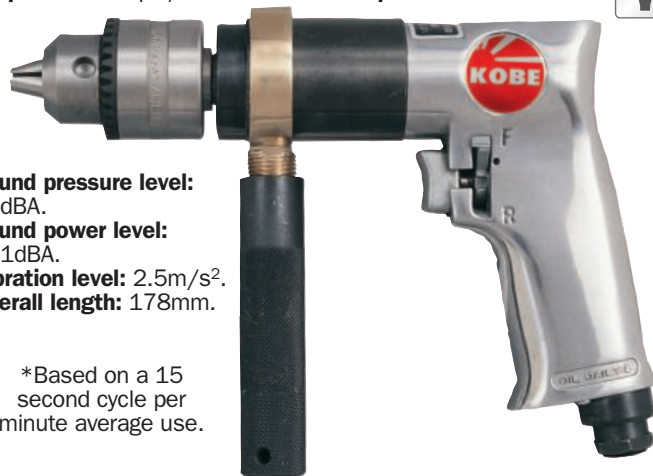

Sound pressure level: 89dBA.
Sound power level: 101dBA.
Vibration level: 2.5m/s².
Overall length: 178mm.

*Based on a 15 second cycle per minute average use.

Free Speed (rpm)	Weight each	Order Code	Price/1 TB
800	1.80kg	KBE-270	7976.00

KOBE 13mm Reversible Pistol Drill

FPD500
Suitable for high torque drilling applications as well as screwdriving, hole sawing and cylinder honing. Rubber handle provides grip and operator comfort. 1/2" chuck. Adjustable side handle. Short gear case design. Heavy duty gearing system with oil-less bushing. Spring loaded rotor vanes. Rear exhaust. Ball bearing construction for a long tool life.

Spindle thread: 3/8" - 24.
Air inlet thread: 1/4" NPT.
Minimum air hose size (ID): 3/8" (10mm).
Air pressure: 90psi/6.2bar.
Air consumption: 3.65cfm*.
Sound pressure level: 95dBA.
Sound power level: 100dBA.
Vibration level: 0.4m/s².
Overall length: 240mm.

*Based on a 15 second cycle per minute average use.

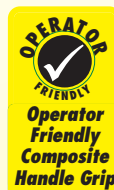

Free Speed (rpm)	Chuck size	Order Code	Price/1 TB
500	1/2" (13mm)	KBE-270	7349.00

KOBE 13mm Reversible Pistol Grip Drill

B2842
Use for drilling and screwdriving. Two speed trigger (slow speed when pushed halfway). Directional lever accessible from both sides for left/right handed use. 13mm (1/2") chuck and detachable side handle included. Planetary gears for longer life and smoother running. Ergonomic comfortable grip.

Chuck size: 1/2" (13mm). **Free speed:** 800rpm.
Recommended air pressure: 6.2bar (90psi).
Air consumption: 4cfm* (113ltr/min).
Air inlet thread: 1/4" NPT.
Spindle thread: 3/8" - 24.
Minimum air hose size (ID): 3/8" (10mm).
Noise level†: 86dBA.
Sound power level†: 93dBA.
Vibration level #: 0.4m/s².
Overall length: 218mm.
†Per EN ISO 15744:2002.
#Per EN 28927-5.



Ergonomic comfortable grip.



Two speed trigger for slow or fast action.



Forward/Reverse lever action.



Complete with industrial chuck.



*Based on a 15 second cycle per minute average use.

Free Speed (rpm)	Weight each	Order Code	Price/1 TB
800	1.30kg	KBE-270	7901.00

GROUP 270 AIR TOOLS - GRINDERS

KOBE High Speed Mini Die Grinder

GD2806L

For precision engineers' mould making etc. Safety lever throttle, front exhaust, ultra compact and lightweight.

Collet size: 6mm. **Air inlet thread:** 1/4" NPT. **Minimum air hose size (ID):** 10mm (3/8"). **Air pressure:** 90psi. **Air consumption:** 4cfm*. **Sound pressure level:** 94dBA. **Sound power level:** 103dBA. **Vibration level:** 5.0m/s². **Overall length:** 120mm.



Uses Long Collet Nut

*Based on a 15 second cycle per minute average use.

Free Speed (rpm)	Weight each	Order Code KBE-270	Price/1 TB
25,000	450g	-2035M	2912.00

Extended Spindle Die Grinder

GES2506L

For extra reach in 'hard to get at' areas, extended spindle housing allowing two-handed operation, rear exhaust, safety lever throttle.

Collet size: 6mm. **Air inlet thread:** 1/4" NPT. **Minimum air hose size (ID):** 10mm (3/8"). **Air pressure:** 90psi. **Air consumption:** 4cfm*.



Uses Long Collet Nut

Sound pressure level: 93dBA. **Sound power level:** 103dBA. **Vibration level:** 5.4m/s². **Overall length:** 248mm.

*Based on a 15 second cycle per minute average use.

Free Speed (rpm)	Weight each	Order Code KBE-270	Price/1 TB
25,000	850g	-2040N	4329.00

Additional Collets

To suit Kobe and similar grinders.

Collet Size	Order Code KBE-280	Price/1 TB
3mm	-0073A	325.00
1/8" (3.175mm)	-0079A	237.00
6mm	-0070A	325.00
1/4" (6.35mm)	-0076A	210.00
Collet Nut (Short)	-0064A	102.00
Collet Nut (Long)	-0067A	115.00

Surface Conditioning & Finishing Kit

Multi-purpose kit containing: one of each of the following surface preparation discs - fine, medium and coarse. 2x abrasive disc grades - P36, P60, P80 and P120. 1x 6mm diameter shank to fit the backing pad. One Kobe angle die grinder with 1/4" NPT air inlet thread for 10mm air hose, 90psi air pressure, 4cfm* air consumption. Supplied in a sturdy plastic carry case.



Uses Long Collet Nut

*Based on a 15 second cycle per minute average use.

Free Speed (rpm)	Weight each	Order Code KBE-270	Price/1 TB
22,000	1.25kg	-7000K	6709.00

Straight Die Grinder

GD2206L

1/2hp motor delivers 22,000 precisely controllable rpm in the palm of your hand making it ideally suitable for polishing, buffing and grinding. The robust and durable single piece aluminium body houses the 1/2hp motor and precision balanced bearings provide reliability in the most demanding of industrial/ automotive applications. The trigger has a safety catch to prevent accidental starts.

Collet size: 6mm. **Air inlet thread:** 1/4" NPT. **Minimum air hose size (ID):** 10mm (3/8"). **Air pressure:** 90psi. **Air consumption:** 4cfm*. **Sound pressure level:** 93dBA. **Sound power level:** 103dBA. **Vibration level:** 5.4m/s². **Overall length:** 170mm.



Uses Short Collet Nut

*Based on a 15 second cycle per minute average use.

Free Speed (rpm)	Weight each	Order Code KBE-270	Price/1 TB
22,000	500g	-2024K	2766.00

Die Grinder Kit

GD22LK

Includes: GD2206L, as shown below left. With 3 and 6mm collets, 10 assorted mounted points and robust blow moulded case.



Uses Short Collet Nut

Free Speed (rpm)	Weight each	Order Code KBE-270	Price/1 TB
22,000	600g	-2030L	3302.00

90° Angle Die Grinder

GDA2206L

Safety lever throttle, reverse exhaust, Ideal for polishing, grinding and buffing, suitable for use in confined areas.

Free speed: 22,000rpm. **Collet size:** 6mm. **Air inlet thread:** 1/4" NPT. **Minimum air hose size:** 10mm (3/8"). **Air pressure:** 90psi/6.2bar. **Air consumption:** 4cfm*. **Sound pressure level:** 85dBA. **Sound power level:** 99dBA. **Vibration level:** 7.0m/s². **Overall length:** 160mm.



Uses Long Collet Nut

*Based on a 15 second cycle per minute average use.

Free Speed (rpm)	Weight each	Order Code KBE-270	Price/1 TB
22,000	500g	-2020H	4860.00

ABRASIVES & POWER TOOLS



KOBE Straight Die Grinder

FDG180m

For polishing, buffing, deburring and grinding. Rubber handle provides grip and operator comfort. Speed regulator, safety release throttle, rear exhaust, ball bearing construction for long tool life.

Contents: mini die grinder, two collet spanners and instructions.

Collet size: 1/4" (6mm).

Air inlet thread: 1/4" NPT.

Minimum air hose size (ID): 3/8" (10mm).

Air pressure: 90psi/6.3bar.

Air consumption: 4cfm* (144ltr/min).

Sound pressure level: 91dBA.

Sound power level: 98dBA.

Vibration level: 4.53m/s².

Overall length: 158mm.



Uses Long Collet Nut



*Based on a 15 second cycle per minute average use.

Free Speed (rpm)	Weight each	Order Code	Price/1 TB
25,000	600g	KBE-270 -2262K	3626.00



Speed regulator



Safety release throttle

Extended Spindle Die Grinder

FDG180e

For polishing, buffing, deburring and grinding. Rubber handle provides grip and comfort. Extended head for flexibility in tight areas. Speed regulator. Safety release throttle. Rear exhaust. Ball bearing construction for long tool life.

Collet size: 6mm.

Air inlet thread: 1/4" NPT.

Minimum air hose size (ID): 3/8" (10mm).

Air pressure: 90psi/6.2bar.

Air consumption: 4cfm*.

Free speed: 25,000rpm.

Sound pressure level: 91dBA.

Sound power level: 98dBA.

Vibration level: 4.53m/s².

Overall length: 235mm.

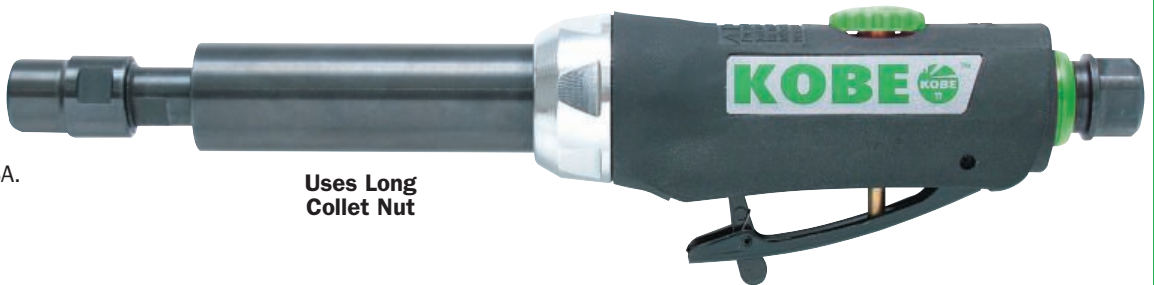

Uses Long Collet Nut



*Based on a 15 second cycle per minute average use.

Free Speed (rpm)	Weight each	Order Code	Price/1 TB
25,000		KBE-270 -2272K	4102.00

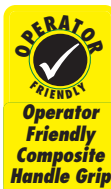

Speed regulator



Safety release throttle

90° Angle Die Grinder

FDG090

For polishing, buffing, deburring and grinding. Rubber handle provides grip and operator comfort. Speed regulator. Safety release throttle. Rear exhaust. Ball bearing construction for long tool life.

Free speed: 22,000rpm.

Collet size: 6mm.

Air inlet thread: 1/4" NPT.

Minimum air hose size (ID): 3/8" (10mm).

Air pressure: 90psi/6.2bar.

Air consumption: 4cfm*.

Sound pressure level: 90dBA.

Sound power level: 97dBA.

Vibration level: 1.24m/s².

Overall length: 160mm.



Uses Long Collet Nut



*Based on a 15 second cycle per minute average use.

Free Speed (rpm)	Weight each	Order Code	Price/1 TB
22,000		KBE-270 -2222K	4600.00

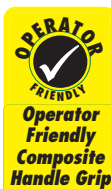

Speed regulator



Safety release throttle

GROUP 270 AIR TOOLS - GRINDERS

KOBE Straight Continuous Use Die Grinder



B3456

Reversible hardened steel 1/4" collet. Short body length allowing access into hard to reach areas. Planetary gears for longer life and smoother running. Low profile teasing throttle for precise speed control. Rotating air inlet to prevent the air hose tangling.

Drive size: 1/4" (6mm), 1/8" (3mm).

Free speed: 25,000rpm.

Air pressure: 6.2bar (90psi).

Air consumption: 4cfm* (113ltr/min).

Air inlet thread: 1/4" NPT.

Minimum air hose size (ID): 10mm (3/8").

Sound pressure level: 91dBA.

Sound power level: 98dBA.

Vibration level: 4.53m/s².

Overall length: 160mm.



Uses Short Collet Nut

CE *Based on a 15 second cycle per minute average use.

Free Speed (rpm)	Weight each	Order Code KBE-270	Price/1 TB
25,000	0.60kg	-4090K	3842.00



Safety release throttle

90° Angle Die Grinder

B3144

Short body length allowing access into hard to reach areas. Planetary gears for longer life and smoother running. Low profile teasing throttle for precise speed control. Rotating air inlet to prevent the air hose tangling.

Collet size: 1/4" (6mm), 1/8" (3mm).

Free speed: 20,000rpm.

Air pressure: 6.2bar (90psi).

Air consumption: 4cfm* (113ltr/min).

Air inlet thread: 1/4" NPT.

Minimum air hose size (ID): 10mm (3/8").

Sound pressure level: 90dBA.

Sound power level: 97dBA.

Vibration level: 1.24m/s².

Overall length: 165mm.



CE *Based on a 15 second cycle per minute average use.

Free Speed (rpm)	Weight each	Order Code KBE-270	Price/1 TB
20,000	0.50kg	-4080K	4925.00



Speed regulator

Safety release throttle

KOBE 115° Angle Die Grinder

FDG115

For polishing, buffing, deburring and grinding. Rubber handle provides grip and operator comfort. 115° angle head for flexibility in tight areas. Speed regulator. Safety release throttle. Rear exhaust. Ball bearing construction for long tool life.

Free speed: 22,000rpm.

Collet size: 6mm.

Air inlet thread: 1/4" NPT.

Minimum air hose size: 3/8" (10mm).

Air pressure: 90psi/6.2bar.

Air consumption: 4cfm*.

Sound pressure level: 90dBA.

Sound power level: 97dBA.

Vibration level: 1.05m/s².

Overall length: 195mm.



Uses Long Collet Nut

CE *Based on a 15 second cycle per minute average use.

Free Speed (rpm)	Weight each	Order Code KBE-270	Price/1 TB
22,000		-2242K	4930.00

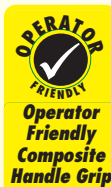

Speed regulator

Safety release throttle

ABRASIVES & POWER TOOLS

KOBE *Extended Straight Die Grinder*



B3555

Use for grinding, polishing, buffing and deburring. The extra length allows you to reach more confined areas. Reversible hardened steel 1/4" collet. Planetary gears for longer life and smoother running. Low profile teasing throttle for precise speed control. Rotating air inlet to prevent the air hose tangling.

Collet size: 1/4" (6mm), 1/8" (3mm).

Free speed: 25,000rpm.

Recommended air pressure: 90psi/6.2bar.

Air consumption: 4cfm* (11.3ltr/min).

Air inlet thread: 1/4" NPT.

Minimum air hose size (ID): 10mm (3/8").

Sound pressure level: 91dBA.

Sound power level: 98dBA.

Vibration level: 4.53m/s².

Overall length: 260mm.



Uses Long Collet Nut

*Based on a 15 second cycle per minute average use.

Free Speed (rpm)	Weight each	Order Code KBE-270	Price/1 TB
25,000	0.68kg	-4140K	4519.00



115° Angle Die Grinder

B3244

Reversible hardened steel 1/4" collet. Short body length allowing access into hard to reach areas. Planetary gears for longer life and smoother running. Low profile teasing throttle for precise speed control. Rotating air inlet to prevent the air hose tangling.

Collet size: 1/4" (6mm), 1/8" (3mm). **Free speed:** 20,000rpm. **Recommended air pressure:** 6.2bar (90psi). **Air consumption:** 4cfm* (11.3ltr/min).

Air inlet thread: 1/4" NPT. **Minimum air hose size (ID):** 10mm (3/8"). **Sound pressure level:** 90dBA. **Sound power level:** 97dBA.

Vibration level: 1.24m/s². **Overall length:** 200mm.



Uses Long Collet Nut

*Based on a 15 second cycle per minute average use.

Free Speed (rpm)	Weight each	Order Code KBE-270	Price/1 TB
20,000	0.55kg	-4110K	5195.00



KOBE *Micro Die Grinder*



GM5603

For precision grinding etc. With hose and silencer, 1/4" NPT air inlet thread for 5mm air hose, 90psi air pressure, 7cfm* air consumption.

Collet size: 3mm. **Free speed:** 56,000rpm. **Sound pressure level:** 76dBA. **Sound power level:** N/A dBA. **Vibration level:** 4.80m/s².

Overall length: 156mm.



Free Speed (rpm)	Weight each	Order Code KBE-270	Price/1 TB
56,000	210g	-2543K	7712.00

Collets

For Kobe and similar micro grinders.

Collet Size	Order Code KBE-280	Price/1 TB
1/8"	-0088A	515.00
3mm	-0091A	515.00
3/32"	-0094A	515.00
Collet nut	-0097A	140.00

*Based on a 15 second cycle per minute average use.



GROUP 270 AIR TOOLS - GRINDERS

KOBE 100mm Angle Grinder

100mm



GA1011L

Adjustable safety guard, safety lever throttle. Supplied with auxiliary side handle, flanges and spanners, lightweight and compact. 100 x 3 x 16mm cut-off disc.

- Air inlet thread:** 1/4" NPT. **Spindle thread:** 3/8" - 24.
- Minimum air hose size:** 10mm (3/8").
- Air pressure:** 6.3bar (90psi).
- Air consumption:** 6cfm* (216ltr/min).
- Motor power:** 0.7hp.
- Sound pressure level:** 89dBA.
- Sound power level:** 96dBA.
- Vibration level:** 4.0m/s².
- Overall length:** 230mm.



*Based on a 15 second cycle per minute average use.

Free Speed (rpm)	Weight each	Order Code KBE-270	Price/1 TB
11,000	1.80kg	-2050P	9404.00

115mm Angle Grinder

GA1211L

Suitable for grinding, cutting-off and sanding. Safety lever throttle. Supplied with auxiliary side handle, flanges and spanners. 115 x 3 x 22mm cut off disc.

- Air inlet thread:** 1/4" NPT. **Spindle thread:** M10 x 1.5mm.
- Minimum air hose size:** 10mm (3/8").
- Air pressure:** 6.3bar (90psi).
- Air consumption:** 6cfm* (216ltr/min).
- Motor power:** 0.7hp.
- Sound pressure level:** 89dBA.
- Sound power level:** 96dBA.
- Vibration level:** 4.0m/s².
- Overall length:** 240mm.



*Based on a 15 second cycle per minute average use.

Free Speed (rpm)	Weight each	Order Code KBE-270	Price/1 TB
11,000	1.80kg	-2060Q	12391.00

180mm Heavy Duty Angle Grinder

GA1807L

Supplied with front exhaust, safety lever throttle, auxiliary side handle and adjustable safety guard. For grinding only.

- Air inlet thread:** 1/4" NPT. **Spindle thread:** 5/8" UNC.
- Minimum air hose size (ID):** 10mm.
- Air pressure:** 90psi. **Air consumption:** 6cfm*.
- Sound pressure level:** 103dBA.
- Sound power level:** 109dBA.



Vibration level: 2.6m/s².
Overall length: 340mm.

*Based on a 15 second cycle per minute average use.

Free Speed (rpm)	Weight each	Order Code KBE-270	Price/1 TB
7,000	3.50kg	-2070R	21102.00

KOBE 50mm Mini Angle Grinder

50mm



FAG050M

For metal dressing, rust removal, weld preparation and automotive bodywork fabrication in hard to reach areas. Speed regulator. Safety release throttle. Heavy duty disc guard. Side exhaust. Ball bearing construction. Supplied with: 2x A60 (KEN230-0040K), 1x A80 (KEN230-0050K) and 1x A120 (KEN230-0060K) 50mm grinding discs.

- Disc size:** 50 x 4 x 9.6mm (2" x 5/32" x 3/8").
- Air inlet thread:** 1/4" NPT.
- Minimum air hose size (ID):** 3/8" (10mm).
- Air pressure:** 90psi/6.3bar.
- Air consumption:** 4cfm*.
- Sound pressure level:** 83dBA.
- Sound power level:** 92dBA.
- Vibration level:** 1.7m/s².
- Overall length:** 140mm.



*Based on a 15 second cycle per minute average use.

Free Speed (rpm)	Weight each	Order Code KBE-270	Price/1 TB
20,000	530g	-2090K	6710.00

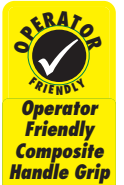

115 & 125mm Angle Grinder

Suitable for metal dressing, rust removal, weld preparation and automotive bodywork fabrication. Rubber-cushioned side handle provides grip and operator comfort.

- Free speed:** 10,000rpm (governed). **Air inlet thread:** 1/4" NPT.
- Spindle thread:** M14 x 2.0mm. **Minimum air hose size:** 10mm (3/8").
- Air pressure:** 6.2bar (90psi). **Air consumption:** 4cfm* (113ltr/min).
- Motor power:** 0.7hp.
- Sound pressure level:** 89dBA.
- Sound power level:** 92dBA.
- Vibration level:** 1.2m/s².
- Overall length:** 240mm.



*Based on a 15 second cycle per minute average use.

Model Number	Disc Size	Free Speed (rpm)	Weight each	Order Code KBE-270	Price/1 TB
FGA120g	115mm (4 1/2")	10,000	1.95kg	-1960K	12391.00
FGA130g	125mm (5")	10,000	1.96kg	-1980K	12716.00



76mm Reversible Cut-off Tool

FCT076

For cutting auto panels, light sheet metal, fibreglass, nuts and bolts. Powerful 0.5HP motor. Speed regulator. Safety release throttle. Rear exhaust. Rotating air inlet. Reverse feature. Ball bearing construction. Supplied with one 76mm cutting disc (KEN230-0020K).

- Disc size:** 76 x 1.8 x 9.6mm (3" x 1/16" x 3/8").
- Minimum air hose size (ID):** 3/8" (10mm).
- Air inlet thread:** 1/4" NPT. **Air pressure:** 90psi/6.2bar.
- Air consumption:** 4cfm*. **Sound pressure level:** 98dBA.
- Sound power level:** 103dBA.
- Vibration level:** 0.5m/s².
- Overall length:** 185mm.



*Based on a 15 second cycle per minute average use.

Free Speed (rpm)	Weight each	Order Code KBE-270	Price/1 TB
18,000	950g	-1200K	5033.00



KOBE Heavy Duty Pistol Grip Hammer

HP2190

For a wide range of workshop and automotive uses. Supplied with retainer spring. Accepts all standard 0.401" shank tools, 1/4" NPT air inlet thread for 10mm air hose, 90psi air pressure, 4cfm* air consumption.

Stroke length: 90mm. **Sound pressure level:** 109dBA. **Sound power level:** 119dBA. **Vibration level:** 11.2m/s². **Overall length:** 225mm.



KOBE COMPLETE RANGE OF SPARE PARTS & ACCESSORIES ARE AVAILABLE

*Based on a 15 second cycle per minute average use.

Blows Per Minute	Weight each	Order Code KBE-270	Price/1 TB
2,100	2.00kg	-3050K	4102.00

Pistol Grip Hammer

HP4540

Suitable for use with cutters, punches, spot weld breakers and flat chisels. Supplied with retainer spring. Accepts all standard 0.401" shank tools, 1/4" NPT air inlet thread for 10mm air hose, 90psi air pressure, 4cfm* air consumption.

Stroke length: 40mm. **Sound pressure level:** 112dBA. **Sound power level:** 121dBA. **Vibration level:** 15.5m/s². **Overall length:** 145mm.



*Based on a 15 second cycle per minute average use.

Blows Per Minute	Weight each	Order Code KBE-270	Price/1 TB
4,500	1.40kg	-3000K	3561.00

Hammer & Chisel Kit

HP5040K

Supplied with flat chisel, spot weld breaker, taper punch and rivet cutter. Variable power regulator. Accepts all standard 0.401" shank tools. 1/4" NPT air inlet thread for 10mm air hose, 90psi air pressure, 4cfm* air consumption.

Stroke length: 40mm. **Sound pressure level:** 112dBA. **Sound power level:** 119dBA. **Vibration level:** 14.8m/s². **Overall length:** 135mm.



*Based on a 15 second cycle per minute average use.

Blows Per Minute	Weight each	Order Code KBE-270	Price/1 TB
5,000	1.60kg	-3150K	2588.00

Hammer & Chisel Kit

HP2090K

Supplied with flat chisel, spot weld breaker, taper punch, rivet cutter and sheet metal cutter. Hard hitting long stroke. Accepts all standard 0.401" shank tools. 1/4" NPT air inlet thread for 10mm air hose, 90psi air pressure, 4cfm* air consumption.

Stroke length: 90mm. **Sound pressure level:** 105dBA. **Sound power level:** 118dBA. **Vibration level:** 11.5m/s². **Overall length:** 230mm.



*Based on a 15 second cycle per minute average use.

Blows Per Minute	Weight each	Order Code KBE-270	Price/1 TB
2,000	3.00kg	-3100K	4211.00

Retainers

Suitable for use with all Kobe air hammers.



Retainer Type	Weight each	Order Code KBE-280	Price/1 TB
Quick Change	60g	-0001A	136.00
Beehive	80g	-0004A	180.00
Zip Change	70g	-0007A	407.00

Air Hammer Chucks

Suitable for use with all Kobe air hammers. Cannot accidentally be released.

Quick Change Chuck
Spring loaded front collar, that must be pulled forward to allow tool release.



Safety Chuck
Spring loaded retainer, that must be unscrewed to allow tool release.



Chuck Type	Weight each	Order Code KBE-280	Price/1 TB
Safety	530g	-0010A	670.00
Quick Change	70g	-0013A	920.00

Needle Scaler Attachment

Converts a pneumatic hammer into a needle scaler.



To Suit	Weight each	Order Code KBE-280	Price/1 TB
All Kobe Air Hammers	865g	-0116A	2318.00

Heavy Duty Needle Scaler

NS4030

10 needles for quick removal of rust, paint, scale, flux and corrosion. Slimline body. Lightweight. (For replacement scaling needles, please refer to parts drawing supplied with tool), 1/4" NPT air inlet thread for 10mm air hose, 90psi air pressure, 4cfm* air consumption.

Needle diameter: 3mm. **Sound pressure level:** 95dBA. **Sound power level:** 109dBA. **Vibration level:** 12.8m/s². **Overall length:** 250mm.

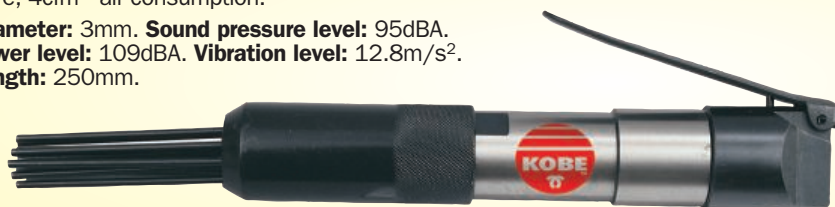

Scaler Needles

For use with Kobe Needle Scaler NS4030.



Blows Per Minute	Weight each	Order Code KBE-270	Price/1 TB
5,000	1.25kg	-3300K	6808.00

*Based on a 15 second cycle per minute average use.

Number of Needles	Weight each	Order Code KBE-280	Price/1 TB
Set 10	140g	-0019A	572.00

KOBE Air Nibbler

NB160

Produces burr-free cuts without distortion. Ideal for body shop and sheet metal work, teasing throttle for precise control, 1/4" NPT air inlet thread for 10mm air hose, 90psi air pressure, 4cfm* air consumption and a cutting capacity of 1.6mm (steel) to 2.0mm (aluminium).

Sound pressure level: 91dBA.

Sound power level: 104dBA.

Vibration level: 5.9m/s².

Overall length: 180mm.



*Based on a 15 second cycle per minute average use.

Cutting Rate Per Min.	Weight each	Order Code KBE-270	Price/1 TB
2.6m	900g	-3400K	5617.00

Punches & Dies for Nibblers

Produce burr-free cuts without distortion. Ideal for body shop and sheet metal work. Suitable for use with Kobe NB160 high performance nibbler. KBE-298 parts cut on upstroke. KBE-280 parts cut on downstroke.

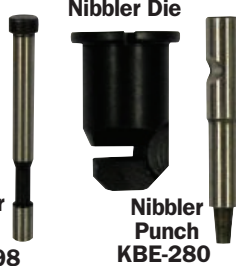

Upstroke				
Type	To Suit Model	Weight each	Order Code KBE-298	Price/1 TB
Punch	Newer	5g	-5003C	328.00
Die	NB160	75g	-5004D	983.00
Downstroke				
Type	To Suit Model	Weight each	Order Code KBE-280	Price/1 TB
Punch	Older	5g	-0025A	309.00
Die	NB160	75g	-0028A	1025.00

Multi-Purpose Body Saw

BS920L

Produces burr-free cuts without distortion. Ideal for body shop and sheet metal work. Teasing throttle for precise control, 1/4" NPT air inlet thread, 90psi air pressure, 4cfm* air consumption and a cutting capacity of 1.6mm (steel) to 2mm (aluminium).

Sound pressure level: 91dBA.

Sound power level: 102dBA.

Vibration level: 5.1m/s². **Overall length:** 235mm.



Free Speed (rpm)	Weight each	Order Code KBE-270	Price/1 TB
9,000	550g	-3500K	6873.00

*Based on a 15 second cycle per minute average use.

Accepts most square-ended blades up to 1mm thick x 12mm wide

Shatter Resistant Body Saw Blades

HSS body saw blade with two tooth pitch variations. 24 tooth (medium) and 32 tooth (fine) to suit a wide range of applications. Sold in packs of two.

All Hard - For Straight Cuts

Teeth Per Inch	Pack Quantity	Order Code KBE-280	Price/1 TB
24	2	-5670K	103.00
32	2	-5672K	103.00

Bi-Metal - For Curved Cuts

Teeth Per Inch	Pack Quantity	Order Code KBE-280	Price/1 TB
24	2	-5674K	115.00
32	2	-5676K	115.00

Rapid Cutting Metal Shear

SH120

Produces burr-free cuts without distortion. Ideal for body shop and sheet metal work. Teasing throttle for precise control, 1/4" NPT air inlet thread for 10mm air hose, 90psi air pressure, 4cfm* air consumption, cutting capacity of 1.2mm steel to 1.6mm aluminium.

Sound pressure level: 82dBA.

Sound power level: N/A dBA.

Vibration level: 4.2m/s².

Overall length: 200mm.



*Based on a 15 second cycle per minute average use.

Strokes Per Min.	Weight each	Order Code KBE-270	Price/1 TB
2,200	2.30kg	-3900K	6808.00

Shear Head

Produces burr-free cuts without distortion. Ideal for body shop and sheet metal work. Suitable for use with Kobe SH120 rapid cutting metal shear.



To Suit Model	Weight each	Order Code KBE-280	Price/1 TB
SH120	360g	-0022A	2575.00

KOBE Pistol Screwdriver Kit

SP1825K

1/4" NPT air inlet thread for 10mm air hose, 90PSI air pressure, 4cfm* air consumption, 45 - 115lbs/inch. 1/4" hex drive capacity.

Sound pressure level: 86dBA.

Sound power level: 102dBA.

Vibration level: 4.6m/s².

Overall length: 178mm.

Contents:

SP1825 screwdriver.
Hexagon wrench and spanner.
No.1, 2 and 3 x 50mm crosspoint bits.
4, 5 and 6mm x 50mm slotted bits.
No.2 x 100mm crosspoint double-ended bit.

*Based on a 15 second cycle per minute average use.

Free Speed (rpm)	Weight each	Order Code KBE-270	Price/1 TB
1800	900g	-3850K	7062.00

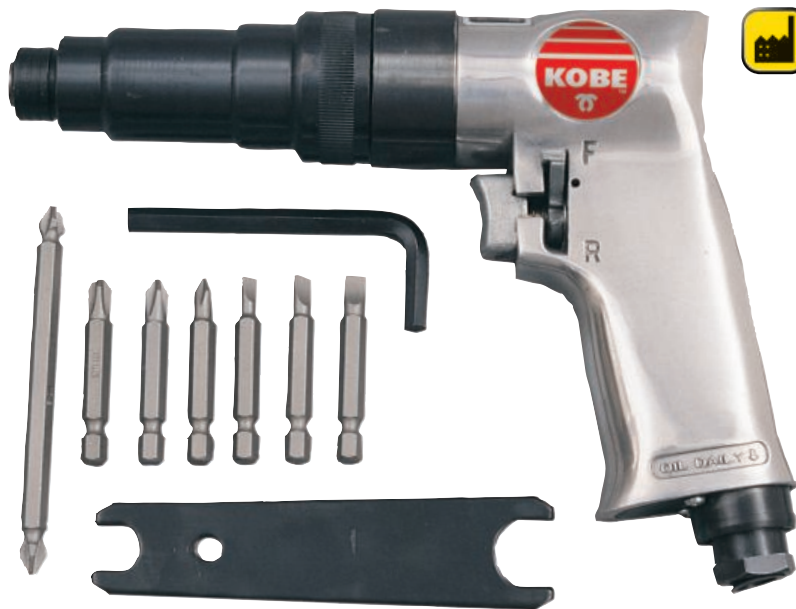

Straight Screwdriver Kit

SS1525K

1/4" NPT air inlet thread for 10mm air hose, 90PSI air pressure, 4cfm* air consumption, 10 - 30lbs/inch torque. 1/4" hex drive capacity.

Sound pressure level: 90dBA.

Sound power level: 104dBA.

Vibration level: 3.2m/s².

Overall length: 210mm.

Contents:

SS1525 screwdriver.
Two clutch springs:
Clutch Spring No.06-703-13
Dia 2.3mm; 1Nm - 3Nm
Clutch Spring No.06-703-23
Dia 1.8mm; 0.3Nm - 0.7Nm
2x spanners. Clutch adjusting wrench.
1/4 NPT nipple. Mini oil bottle.
No.1 x 65mm crosspoint double ended bit.
5 x 50mm slotted bit.

*Based on a 15 second cycle per minute average use.

Free Speed (rpm)	Weight each	Order Code KBE-270	Price/1 TB
1700	900g	-3800K	6818.00



KOBE Automatic Shut-off Screwdriver 0.6 - 5.1Nm

CSP005S

Heavy-duty reverse action pistol grip screwdriver suitable for production and assembly applications.

Push to start type with auto shut-off clutch for precision applications.

Three interchangeable torque springs allow for easy conversion for new applications. 1/4" hex drive. External torque adjustment does not require disassembly of the tool. Variable speed throttle.

Ergonomically contoured grip for operator comfort.

Handle exhaust directs air away from the workpiece and operator. Hanging ring included.

Chuck size: 1/4" (6mm) hex.

Air inlet thread: 1/4" NPT.

Minimum air hose size (ID): 3/8" (10mm).

Green torque spring:* 0.6 - 2.1Nm (5 - 19in/lbs).

Black torque spring: 1.1 - 4.3Nm (10 - 38in/lbs).

Yellow torque spring: 1.7 - 5.1Nm (15 - 45in/lbs).

Air pressure: 6.3bar/90psi.

Air consumption: 4cfm* (144ltr/min).

Sound pressure level: 84dBA.

Sound power level: 93dBA.

Vibration level: <0.5m/s².



*Based on a 15 second cycle per minute average use.

Overall Length	Weight each	Order Code KBE-270	Price/1 TB
210mm	815g	-3760K	13419.00



PRODUCTS ARE ONLY AVAILABLE VIA YOUR DISTRIBUTOR

ABRASIVES & POWER TOOLS

GROUP 270 AIR TOOLS - SANDERS

KOBE 75mm Air Random Orbital Sander

BROS3 - Heavy Duty

High speed random orbital sander with an adjustable power regulator to match the speed to the job. Provides a smooth, swirl-free finish whilst the ergonomic hand grip offers enhanced user comfort. Compact, lightweight design makes it easy to use in confined areas. Ball bearing construction for long tool life.

Motor power: 0.40hp
Air inlet thread: 1/4" BSP.
Backing pad size: 75mm (3").
Sound power level: 91dBA.
Vibration level: 6.3m/s².
Free speed: 15,000rpm.
Backing pad: Hook-n-Loop.
Operating pressure: 90psi/6.2bar.
Minimum air hose size (ID): 3/8" (10mm).
Overall length: 125mm.

Free Speed (rpm)	Weight each	Order Code	Price/1 TB
15,000		-6010K	6179.00

NEW



75 mm



KOBE Mini Random Orbital Sander Kit

F05003mk

Uses 2" and 3" backing pads. Rubber handle provides grip and operator comfort. Two finger throttle for easier control and less fatigue. Adjustable power regulator to match the speed to the job. Ball bearing construction for a long tool life.

Accessories included: 2" and 3" backing pads. 10x 2" diameter sanding discs - 320, 400 and 600 grit. 10x 3" diameter sanding discs - 320, 400 and 600 grit. Spindle key and instructions. Supplied in a robust blow-moulded carry case.

Free speed: 15,000rpm.
Air inlet thread: 1/4" NPT.
Minimum air hose size (ID): 3/8" (10mm).
Air consumption: 4cfm*.
Vibration level: 0.9m/s².

CE *Based on a 15 second cycle per minute average use.

Free Speed (rpm)	Weight each	Order Code	Price/1 TB
15,000	611g	-2103K	5184.00



ABRASIVES & POWER TOOLS

150mm Random Orbital Sander

FS0150

Suitable for shaping, blending, smoothing body filler and rapid material removal. Rubber handle. Random orbit. Can be used for wet sanding. Rotating air inlet to prevent tangling. Speed control for easy adjustment. Ball bearing construction for a long tool life.

Backing pad size: 150mm (6"). **Backing pad type:** hook and loop. **Orbit diameter:** 5mm (3/16"). **Suction type:** Self-generating vacuum. **Spindle size:** 5/16" NPT. **Free speed:** 10,000rpm. **Air inlet thread:** 1/4" NPT. **Minimum air hose size (ID):** 10mm (3/8"). **Air pressure:** 6.2bar/90psi. **Motor power:** 0.2hp. **Air consumption:** 3cfm* (85ltr/min). **Sound pressure level:** 84dBA. **Sound power level:** 90dBA. **Vibration level:** 5.6m/s². **Overall length:** 280mm.



Free Speed (rpm)	Weight each	Order Code	Price/1 TB
10,000	1.04kg	-2720K	11688.00

*Based on a 15 second cycle per minute average use.



Mini Polisher Kit

GMPK3 - 75mm (3") Mini Polisher Kit

Compact and lightweight for ease of use in confined areas. Ergonomic and comfortable hand grip.

Kit contents: mini polisher, backing pad, spanner, 90mm (3") fine polishing sponge (white), 90mm (3") coarse polishing sponge (yellow) and 90mm (3") lambs wool polishing bonnet.

Motor power: 0.25hp.
Air inlet thread: 1/4" BSP.
Backing pad size: 75mm (3").
Sound power level: 94dBA.
Vibration level: 0.77m/s².
Free speed: 3,200rpm.
Backing pad: Hook-n-Loop.
Operating pressure: 90psi/6.2bar.
Minimum air hose size (ID): 3/8" (10mm).
Overall length: 115mm.

Free Speed (rpm)	Weight each	Order Code	Price/1 TB
3,200		-6740K	5923.00

6 PIECES

NEW



75 mm



KOBE 150mm Random Orbital Palm Sander Self-Vacuum Type

R5666
Suitable for shaping, blending and smoothing of body filler and rapid material removal. Random 5mm diameter orbit for a swirl-free finish - can be used for wet sanding. 150mm diameter Hook-n-Loop backing pad with a 600A hole pattern. 1.6m extraction hose. Can be connected to a portable dust collection system or supplied cotton bag to help reduce airborne dust and clean-up time. One handed operation with a rubber grip. Rotating air inlet to prevent the air hose tangling.

Backing pad size: 150mm (6"). **Backing pad type:** Hook-n-Loop.
Orbit diameter: 5mm (3/16"). **Suction type:** self-generating vacuum.
Spindle size: 5/16". **Free speed:** 11,000rpm.
Recommended air pressure: 6.2bar/90psi.
Air consumption: 3cfm* (85ltr/min).
Air inlet thread: 1/4" NPT. **Minimum air hose size (ID):** 10mm (3/8").
Motor power: 0.25hp. **Sound pressure level:** 88dBA.
Sound power level: 76dBA. **Vibration level:** 5.2m/s².
Overall length: 210mm.



Free Speed (rpm)	Weight each	Order Code KBE-270	Price/1 TB	*Based on a 15 second cycle per minute average use.
11,000	1.47kg	-4170K	10363.00	

Dust Free Orbital Palm Grip Sander

FPS874
Complete with 1m dust removal hose, large capacity dust collection bag and foam backed velcro pad. Connects to dust extraction. Adjustable speed regulator.

Air inlet thread: 1/4" NPT.
Minimum air hose size (ID): 3/8" (10mm).
Air pressure: 6.3bar/90psi.
Air consumption: 4cfm* (144ltr/min).
Sheet size: 93 x 230mm.
Pad size: 165 x 74mm.
Overall length: 175mm.



Free Speed (rpm)	Weight each	Order Code KBE-270	Price/1 TB	*Based on a 15 second cycle per minute average use.
8,000	1.80kg	-2650K	11093.00	

AIR TOOLS - SANDERS

1/3 Sheet Heavy Duty Orbital Sander

FOS890
For use on wood, metal, plastics, fibre glass, fillers etc. Connects to 10mm hose, dust extraction, adjustable speed regulator, low noise, vibration damped.

Pad size: 165 x 90mm.
Sheet size: 93 x 230mm.
Air inlet thread: 1/4" NPT.
Minimum air hose size (ID): 3/8" (10mm).
Air pressure: 6.3bar/90psi.
Air consumption: 4cfm* (144ltr/min).
Sound pressure level: 91dBA.
Sound power level: 105dBA.
Vibration level: 16.6m/s².
Overall length: 175mm.



Free Speed (rpm)	Weight each	Order Code KBE-270	Price/1 TB	*Based on a 15 second cycle per minute average use.
8,000	1.80kg	-2900K	4977.00	

180mm Angle Polisher

PA1825
For high performance buffing and polishing on bodywork and paintwork. Built-in regulator for consistent performance. Can be used with compounding heads and polishing sponges.

Spindle thread: 5/8" - 11 NPT.
Air inlet thread: 1/4" NPT.
Minimum air hose size (ID): 3/8" (10mm).
Air pressure: 6.3bar/90psi.
Air consumption: 4cfm* (144 ltr/min).
Pad size: 180mm.
Sound pressure level: 96dBA.
Sound power level: 103dBA.
Vibration level: 8.2m/s².
Overall length: 380mm.



Free Speed (rpm)	Weight each	Order Code KBE-270	Price/1 TB	*Based on a 15 second cycle per minute average use.
2,500	2.30kg	-3600K	11417.00	



ABRASIVES & POWER TOOLS

180 mm



PRODUCTS ARE ONLY AVAILABLE VIA YOUR DISTRIBUTOR

KOBE Mini Belt Sander Kit

MBS025-X

Suitable for shaping, paint removal, weld sanding, smoothing and rust removal on flat or curved surfaces. Supplied with 9 flexible abrasive belts and 5 contact arms. Rated for continuous use. Uses 6, 10, 13 and 20mm wide by 457mm long abrasive belts. Adjustable multi-positional sanding arm angle with a speed regulator and rear handle exhaust with noise baffle.

Free speed: 18,000rpm.
Air inlet thread: 1/4" NPT.
Minimum air hose size (ID): 10mm (3/8").
Air consumption: 4cfm* (113ltr/min).
Air pressure: 90psi/6.3bar.
Motor power: 0.6hp.
Sound pressure level: 84dBA.
Sound power level: 92dBA.
Vibration level: 0.80m/s².
Overall length: 390mm.



6-20 mm



Kit contents:
Contact arms:
 6, 10, 13, 20mm with flat roller.
 10mm with rounded roller.
Surface preparation file belts:
20mm: P80 grit (coarse),
13mm: P300 grit (fine)
Aluminium oxide file belts:
20mm: P60, P80 grit,
13mm: P80, P120 grit,
10mm: P120, P150 grit,
6mm: P150 grit.
 4mm hexagon key L-wrench.

File Belt

Grit	Weight per 10	Order Code	Price/100 TB
		YRK-204	
		13mm Wide x 457mm Long	
P80	600g	-3342K	4378.00



Free Speed (rpm)	Weight each	Order Code	Price/1 TB
18,000	1.36kg	KBE-270 -2880K	15686.00

ABRASIVES & POWER TOOLS

KOBE Mini Belt Sanders

Suitable for flat, concave and convex surfaces. Sanding arm can be rotated to any angle - improved access in confined spaces, saves space when storing the tool. Spare belt and hex wrench included. Ergonomic and comfortable rubber grip for reduced vibration. Low profile teasing throttle for precise speed control. Directional rear exhaust.

Air inlet thread: 1/4" NPT
Minimum air hose size (ID): 10mm (3/8").
Air consumption: 4cfm* (113ltr/min).
Air pressure: 90psi/6.2bar.
Overall length/folded length:
R5218: 305/207mm,
R5228: 470/310mm,
R5238: 420/255mm.



*Based on a 15 second cycle per minute average use.

Model Number	Belt Size W x L (mm)	No Load Speed	Weight each	Order Code	Price/1 TB
R5218	6 x 330	18,000rpm	0.85kg	-4250K	11417.00
R5228	13 x 610	18,000rpm	0.95kg	-4270K	12500.00
R5238	20 x 520	16,000rpm	1.60kg	-4200K	16503.00



KOBE Speed Ratchets

SR375 3/8" square drive, 10mm bolt capacity.

SR500 1/2" square drive, 13mm bolt capacity.

Ball type retainer, disc type reversing action, compact, lightweight design, ideal for automotive work, front exhaust.

Free speed: 150rpm.

Air inlet thread: 1/4" NPT.

Minimum air hose

size (ID): 10mm (3/8").

Air pressure: 6.2bar/90psi.

Air consumption:

4cfm* (113ltr/m).

Torque: 50ft./lbs.

Overall length: 255mm.



3/8

1/2

KBE - 270

Sound pressure level:	2375K 89dBA	2500K 89dBA
Sound power level:	96dBA	89dBA
Vibration level:	4.0m/s ²	4.0m/s ²

*Based on a 15 second cycle per minute average use.

Model Number	Square Drive	Weight each	Order Code KBE-270	Price/1 TB
SR375	3/8"	1.10kg	-2375K	3355.00
SR500	1/2"	1.10kg	-2500K	3383.00

Speed Ratchet 1/4" Square Drive

R7722

Suitable for the removal and installation of threaded fasteners. Reversible hardened steel 1/4" square drive. Short body length allowing access into hard to reach areas. Planetary gears for longer life and smoother running. Low profile throttle for precise speed control. Rotating air inlet to prevent the air hose tangling.

Drive size: 1/4" (6mm).

Free speed: 200rpm.

Recommended air pressure: 6.2bar/90psi.

Air consumption: 4cfm* (113ltr/min).

Working torque range:

7 ~ 27nm (5 ~ 20ft./lbs).

Air inlet thread: 1/4" NPT.

Minimum air hose

size (ID): 10mm (3/8").

Sound pressure level: 80dBA.

Sound power level: 88dBA.

Vibration level: 1.8m/s².

Overall length: 200mm.



1/4



Protective rubber head cover

Lever operated throttle

Directional rear exhaust

Forward/Reverse lever switch

Adjustable air (speed) regulator

Vibration dampened rubber grip

*Based on a 15 second cycle per minute average use.

Overall Length	Weight each	Order Code KBE-270	Price/1 TB
200mm	0.65kg	-4010K	4644.00

ABRASIVES & POWER TOOLS

KOBE Speed Ratchets

FSR375 3/8" square drive. **Working torque range:** 5 - 20ft.lbs (7 - 27Nm).

FSR500 1/2" square drive. **Working torque range:** 10 - 50ft.lbs (14 - 68Nm).

Overall length: 205mm. **Free speed:** 200rpm.

Overall length: 265mm. **Free speed:** 150rpm.

3/8

1/2

Suitable for the removal and installation of threaded fasteners when doing automotive and light assembly work.

Reversible hardened steel square drive. Rubber handle provides grip and operator comfort with reduced hand chill. Three planetary gears for longer life and smoother running. Rubber cover protects the ratchet head and the workpiece. Short body length allows access into hard to reach areas. Low profile teasing throttle for precise speed control. Rotating rear exhaust with baffle for reduced noise. Rotating air inlet to prevent the air hose tangling. Adjustable air regulator.

Air inlet thread: 1/4" NPT.

Minimum air hose size

(ID): 10mm (3/8").

Air pressure: 6.2bar/90psi.

Air consumption:

4cfm* (113ltr/min).

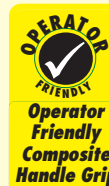

KBE - 270

Sound pressure level:	2360K 84dBA	2300K 80dBA
Sound power level:	88dBA	87dBA
Vibration level:	1.8m/s ²	2.6m/s ²

*Based on a 15 second cycle per minute average use.

Model Number	Square Drive	Working Torque Range	Overall Length	Weight each	Order Code KBE-270	Price/1 TB
FSR375	3/8"	7 - 27Nm	205mm	640g	-2360K	4466.00
FSR500	1/2"	14 - 68Nm	265mm	1.20kg	-2300K	4303.00

PRODUCTS ARE ONLY AVAILABLE VIA YOUR DISTRIBUTOR

KOBE Impact Wrench



G7321

Suitable for light workshop and garage use. Twin hammer mechanism with a 4-point adjustable air (speed) forward/reverse speed regulator. Ergonomic and comfortable handle grip with vibration dampening a fixed inlet and exhaust. One finger stop/start trigger operation. Downward facing external exhaust in handle.

Free speed: 10,100rpm, forward: position 1: 8,000rpm, position 2: 9,100rpm, position 3: 10,100rpm, reverse: 10,200rpm.



Maximum torque: 393Nm (290ft/lbs).
Working torque: 339Nm (250ft/lbs).
Recommended air pressure: 6.2bar (90psi).
Air consumption: 3.4cfm*
Air inlet thread: 1/4" NPT.
Minimum air hose size (ID): 10mm (3/8").
Overall length: 160mm.

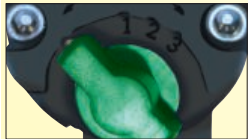

Free Speed (rpm)	Weight each	Order Code	Price/1 TB
10,100		KBE-270	9199.00

*Based on a 15 second cycle per minute average use.

KOBE Impact Wrench



B7444

Suitable for production and assembly applications. Twin hammer mechanism. Three position dial style speed regulator. Forward/reverse selection. Ergonomic and comfortable handle grip. Fixed inlet and exhaust.

Forward: position 1: 4,000rpm, position 2: 5,000rpm, position 3: 7,000rpm.

Reverse: position 1: 3,000rpm, position 2: 5,000rpm, position 3: 7,000rpm.

Collet size: 1/2" (13mm).
Free speed: 7,000rpm.



Maximum torque: 813Nm (600ft/lbs).
Recommended air pressure: 6.2bar/90psi.
Air consumption: 4cfm* (1.13ltr/min).
Air inlet thread: 1/4" NPT.
Minimum air hose size (ID): 10mm (3/8").
Sound pressure level: 83dBA.
Sound power level: 90dBA.
Vibration level: 6.8m/s².
Overall length: 183mm.



Free Speed (rpm)	Weight each	Order Code	Price/1 TB
7,000	1.94g	KBE-270	10336.00

*Based on a 15 second cycle per minute average use.

KOBE Impact Wrench



IW500

One piece aluminium housing, 10 position power regulator, thumb switch for reversing, 1/4" NPT air inlet thread for 10mm air hose, 90psi air pressure, 300ft/lbs torque, 4cfm* air consumption, 16mm bolt capacity.

Sound pressure level: 88dBA. **Sound power level:** N/A dBA.
Vibration level: 4.2m/s². **Overall length:** 191mm.



Free Speed (rpm)	Weight each	Order Code	Price/1 TB
7,000	2.30kg	KBE-270	6656.00

*Based on a 15 second cycle per minute average use.

Impact Wrench Kit



IWS500

Kit supplied complete in robust blow-moulded case.

Includes: 1/2" impact wrench IW500. 10 metric sockets: 9 - 27mm. Threaded tailpiece, in-line mini-oiler and oil bottle. One piece aluminium housing, 10 position power regulator, thumb switch for reversing, 1/4" NPT air inlet thread for 10mm air hose, 90psi air pressure, 300ft/lbs torque, 4cfm* air consumption, 16mm bolt capacity.

Sound pressure level: 93dBA. **Sound power level:** N/A dBA.
Vibration level: 1.219m/s². **Overall length:** 191mm.



Free Speed (rpm)	Weight each	Order Code	Price/1 TB
7,000	4.30kg	KBE-270	8225.00

*Based on a 15 second cycle per minute average use.

KOBE Impact Wrench



3/4

IW750

One-piece aluminium housing, 10 position power regulator, thumb switch for reversing, 1/4" NPT air inlet thread for 10mm air hose, 25mm bolt capacity. 90psi air pressure, 7.5cfm* air consumption. 500ft/lbs torque.

Sound pressure level: 83dBA.
Sound power level: N/A dBA.
Vibration level: 0.449m/s².
Overall length: 245mm.



Free Speed (rpm)	Weight each	Order Code KBE-270	Price/1 TB
4,200	5.00kg	-2325S	13798.00

*Based on a 15 second cycle per minute average use.

KOBE Pistol Grip Air Impact Wrench



1

IWP100-X

Suitable for industrial and commercial production and assembly applications. Front or rear mounting spring balance loop. Forward/reverse switch and three position power regulator. Forward facing exhaust. Oiling points for daily maintenance.

Free speed: 3,400rpm.
Final drive: 1" (25mm) hex.



Working torque: 2,170Nm (1600lb/ft).
Maximum torque: 2,440Nm (1800lb/ft).
Air inlet thread: 1/2" NPT.
Minimum air hose size (ID): 1/2" (13mm).
Air pressure: 6.3bar/90psi.
Air consumption: 5.95cfm.
Sound pressure level: 87dBA.
Vibration level: 5.9m/s².
Overall length: 295mm.



Free Speed (rpm)	Weight each	Order Code KBE-270	Price/1 TB
3,400	9.70kg	-1620A	25425.00

*Based on a 15 second cycle per minute average use.

KOBE Heavy Duty In-Line Air Impact Wrench

1" square drive. Suitable for industrial and commercial production and assembly applications. Side handle for two-handed operation. Top mounted spring balance loop. Easy to use forward/reverse switch and three position power regulator. Top venting exhaust. Oiling points for daily maintenance.

Free speed: 3,300rpm.
Final drive: 1" (25mm) hex.
Working torque: 2,030Nm (1500lb/ft).
Maximum torque: 2,300Nm (1700lb/ft).
Safe working pressure: 6.2bar/90psi.
Air inlet thread: 1/2" NPT.
Minimum air hose size (ID): 1/2" (13mm).
Air pressure: 6.3bar/90psi.
Air consumption: 7.0cfm.
Sound pressure level: 87dBA.
Vibration level: 5.9m/s².
Overall length: 500mm.



Free Speed (rpm)	Weight each	Order Code KBE-270	Price/1 TB
3,300	9.34kg	-1630B	34505.00

*Based on a 15 second cycle per minute average use.



ABRASIVES & POWER TOOLS

GROUP 271 MACHINE TOOLS - DRILLS & MILLS

OSAKI POWER TOOLS Mini Milling/Drilling Machine

A must for model makers. Bench mounted, this milling/drilling machine has a spindle rotation of up to 45°, making it a very capable tool. An assortment of useful accessories are available (see list). This versatile tool has been manufactured to meet European Machinery Directive 98/37/EC and is both CE and RoSH compliant.

- Swing over bed:** 180mm.
- Drilling capacity:** 13mm.
- End milling capacity:** 16mm.
- Face milling capacity:** 30mm.
- Headstock travel (Z):** 180mm.
- Cross axis:** 100mm.
- Longitudinal axis:** 220mm.
- Spindle rotary angle:** ±45.
- Output power:** 350W.
- Spindle speed:**
- Low range**
- 0 - 1100rpm ±10%.
- High range**
- 0 - 2500rpm ±10%.
- Spindle taper:** MT#3.
- T-slot:** 12mm.
- Net/gross weight:** 50/68kg.
- Packing size:** 540 x 500 x 760mm.



FOR DIY USE
Not warranted for Industrial Use

Model Number	Volts	Motor	Order Code OSA-271	Price/1 TB
01490	240	350W (¾hp)	-5500K	54075.00



Toolmaker's Vices

Made from alloy steel with a quick release mechanism and knurled grip handle. For use with mini milling/drilling machines.

Jaw dimensions (W x O x H):
100 x 85 x 28mm.

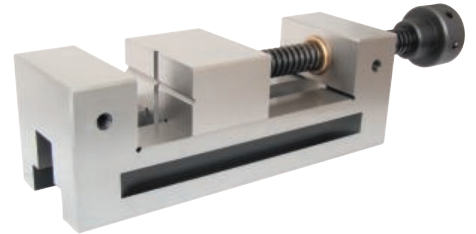

Jaw Dimension Width x Opening x Height	Order Code OSA-280	Price/1 TB
100 x 85 x 28mm	-2410A	5408.00

10126



Product Number

Description

10037



Order Code OSA-280

Price/1 TB

10126	3MT Direct Drive Collet Set	-2411A	6129.00
10037	3MT Double Angle Collet Set	-2412A	11588.00
10046	3MT Indexable Milling Cutter	-2413A	5149.00
-	Chuck Guard Assembly	-2414A	773.00

ABRASIVES & POWER TOOLS

Mini Metalworking Lathe

This little gem is ideal for model-making etc. Supplied with a self-centring three jaw chuck, four-way tool post, swarf tray, rear splash guard, emergency stop button and chuck guard. A variety of useful accessories are available (see list). Manufactured to meet European Machinery Directive 98/37/EC and is both CE and RoSH compliant.

- Swing over bed:** 180mm.
- Distance between centres:** 300mm.
- Hole through spindle:** 20mm.
- Spindle taper:** MT#3.
- Tailstock taper:** MT#2.
- Spindle speed:**
- Low range:** 0 - 1100rpm ±10%.
- High range:** 0 - 2500rpm ±10%.
- Output power:** 300W.
- Range of threads:** metric 0.4 - 2.00mm (10 thread pitches) or inch 12 - 52 TP (8 thread pitches).
- Net/gross weight:** 37/40kg.
- Packing size:** 770 x 330 x 330mm.

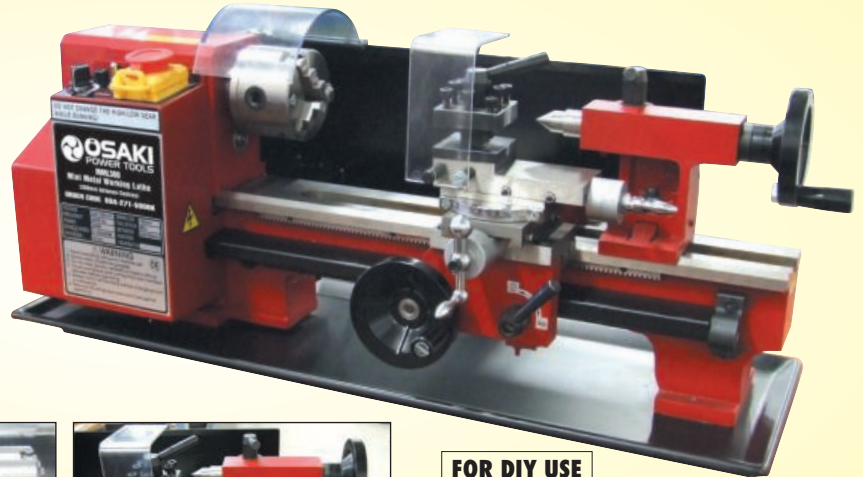

FOR DIY USE
Not warranted for Industrial Use



Description	Volts	Motor	Order Code OSA-271	Price/1 TB
Mini Lathe	240	300W	-5000K	53045.00

Optional Accessories

Supplied Separately

Product Number	Description	Order Code OSA-280	Price/1 TB
10007	160mm Diameter Face Plate	-2400A	1906.00
10007A	Clamping Kit for Face Plate	-2401A	1236.00
10010	4 Jaw Chuck (Independent)	-2402A	6695.00
10005	11 Piece Brazed Turning Tool Set	-2403A	2936.00
10006	6 Piece Brazed Turning Tool Set	-2404A	1494.00
10130	Knurling Attachment	-2405A	2823.00
10061	Milling Attachment	-2406A	12618.00
-	Chuck Guard Assembly	-2407A	1338.00

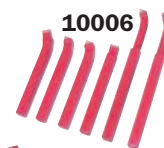
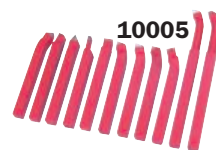

KOBE Bench Pillar Drills

Industry standard Morse Taper specification pillar drills, suitable for workshop and light industrial use with a tilting rise and fall work table, user friendly depth gauge, telescopic chuck guard, integral bit drawer and laser beam target guide for quick positioning of repeat work.

DPB350

This drill has a smooth running 350W motor which provides enough power to drill holes up to 13mm and five speeds for versatility and performance when drilling different materials.

- Spindle taper:** MT2.
- Chuck:** 13mm.
- Drill capacity:** 13mm.
- Spindle travel:** 50mm.
- Speeds:** 5.
- Speed range:** 580 - 2,650rpm.
- Maximum distance - chuck/table:** 250mm.
- Maximum distance - chuck/base:** 250mm.
- Maximum distance - spindle to column:** 102mm.
- Column diameter:** 50mm.
- Table size:** 152 x 170mm.
- Complete with side plates:** 192 (max 272) x 170mm.
- Base size:** 320 x 190mm.



DPB350

350 WATT
13 AMP
CLASS 2 LASER



Model Number	Net Weight	Order Code	Price/1 TB
DPB350	24kg	KBE-271-2030K	10815.00

DPB500

More versatile than its smaller stable mate. 500W motor provides more power to drill holes up to 16mm with 12 speeds for increased performance when drilling on either the table or base.

- Spindle taper:** MT2.
- Chuck:** 16mm.
- Drill capacity:** 16mm.
- Spindle travel:** 65mm.
- Speeds:** 12.
- Speed range:** 425 - 2,545rpm.
- Maximum distance - chuck/table:** 355mm.
- Maximum distance - chuck/base:** 465mm.
- Maximum distance - spindle to column:** 126mm.
- Column diameter:** 60mm.
- Table size:** 200 x 200mm.
- Complete with side plates:** 200 x 340mm.
- Base size:** 380 x 250mm.



DPB500

500 WATT
13 AMP
CLASS 2 LASER



Model Number	Net Weight	Order Code	Price/1 TB
DPB500	39.5kg	KBE-271-2110K	15965.00

Floor Standing Pillar Drill

DPF550

Suitable for industrial use on much larger workpieces. Its 550W motor and 12 speeds which give optimal performance when drilling holes up to 20mm. It also comes with a no-volt auto-release switch which turns off when voltage is removed by power cut etc. This stops the machine from starting up on its own when power is restored.

The tilting work table with rise and fall rack and pinion can rotate to the rear of the pillar to accommodate larger workpieces on the base plate.

- Spindle taper:** MT2.
- Chuck:** 16mm.
- Drill capacity:** 20mm.
- Spindle travel:** 80mm.
- Speeds:** 12.
- Speed range:** 200 - 2,600rpm.
- Maximum distance - chuck/table:** 725mm.
- Maximum distance - chuck/base:** 1,220mm.
- Maximum distance - spindle to column:** 190mm.
- Column diameter:** 80mm.
- Table size:** 300 x 300mm.
- Base size:** 500 x 300mm.



DPF550

550 WATT
13 AMP



Model Number	Net Weight	Order Code	Price/1 TB
DPF550	79kg	KBE-271-2210K	27295.00



OSAKI 5-Speed Bench Drill

This versatile machine has a smooth running 350W motor for drilling holes up to 13mm. It can be set to five different speeds for versatility and performance when drilling different materials. Complete with a tilting rise and fall work table it operates from a standard 13amp plug.

- Power input:** 350W.
- Motor output:** 210W.
- Supply voltage:** 230V - 50Hz.
- Spindle travel:** 50mm.
- Spindle taper:** MT2.
- Table size:** 156 x 160mm.
- Base size:** 314 x 200mm.
- Column diameter:** 46mm.
- Drilling speed:** 580 - 2650rpm.
- Sound power:** 75.1dBA.
- Sound pressure:** 62.1dBA.
- Maximum distance from spindle axis to surface of column:** 104mm.
- Maximum distance from spindle end to surface of table:** 200mm.
- Maximum distance from spindle end to surface of base:** 290mm.
- Overall size:** 355 x 225 x 580mm.



FOR DIY USE
Not warranted for Industrial Use

Model Number	Voltage	Net Weight	Order Code	Price/1 TB
PDB132	240V	19kg	OSA-279-9340K	5923.00

ABRASIVES & POWER TOOLS

KOBE Portable Petrol Generator

GPP230

- Ideal for builders, contractors, mobile caterers, etc.
- Powers lighting, freezers, power tools, water pumps and other electrical items. • Brushless alternator type.
- 2.3kVA/2.3kW maximum power. • 2kVA/2kW continuous power
- One 220V AC and one 110V AC outlet. • Voltmeter.
- Circuit breakers.
- 12ltr fuel tank with fuel level indicator.
- Approximately 9hrs running time.
- Motor: 4-stroke, 6.0hp, OHV, single cylinder, air cooled engine that runs on unleaded petrol.
- Low oil alert and shutdown.
- Recoil starter.
- Anti-vibration mounts.

Dimensions (H x W x D):
425 x 515 x 430mm.



Product Number	Motor	Weight each	Order Code KBE-273	Price/1 TB
GPP230	6.0hp	42.0kg	-3100K	25750.00

Oil-free Compressors



1.5hp 6ltr Compressor

This compressor may be small in size and weight (only 18.6kg) but it has an output of up to 8bar producing up to 115psi and 140ltr/min. Suitable for DIY, home improvement and workshop use, NOT suitable for continuous use.



MOTOR 1.5hp
RECEIVER 6ltr

Product Number	Motor	Maximum Delivery	Maximum Pressure	Receiver Size	Order Code KBE-273	Price/1 TB
CNL156	1.5hp	5.0cfm	8bar	6ltr	-1000K	16995.00



Oil-free Compressor



GTS800

Suitable for DIY and hobby use, this oil-free compressor is easy to start up and dry and clean to use. It operates from a standard 13 amp plug and is mounted on wheels for easy manoeuvrability. Features automatic safety valve, pressure cut-off switch, thermal overload protector and fully automatic stop/start control.

NEW



Receiver Size	Weight each	Order Code OSA-273	Price/1 TB
24ltr		-0120K	17500.00

2 Stroke Petrol Generator

GTS800

- Suitable for DIY and hobby use.
- Runs small power tools, freezers lights etc.
- Smooth running 2-stroke 2hp easy start engine.
- 5.8hrs running time from a 4.2ltr fuel tank.
- 800W peak power, 650W continuous.
- 12V DC battery charging outlet with lead and clamps.
- Maintenance free brushless alternator.
- 13amp 240V outlet socket.
- Overload circuit breakers.
- Anti-vibration feet.

Dimensions (H x W x D):
365 x 360 x 330mm.



Product Number	Motor	Weight each	Order Code OSA-273	Price/1 TB
GTS800	2.0hp	20.5kg	-3000K	8239.00

2hp 23ltr Compressor

These Direct Drive oil-free compressors are built of quality materials to ensure trouble free use and can be run on a normal 240V domestic supply. Robust in manufacture, they all come with a pressure cut-off switch, fully automatic stop/start control, tank and line pressure gauges and an air outlet regulator.

Robust 2hp direct drive motor producing an 8bar/115psi working pressure and an air supply of 8cfm/230ltr/min which is enough to run most air tools.



MOTOR 2.0hp
RECEIVER 23ltr

Product Number	Motor	Maximum Delivery	Maximum Pressure	Receiver Size	Order Code KBE-273	Price/1 TB
CNL223	2.0hp	8.0cfm	8bar	23ltr	-1050K	20085.00

2hp 46ltr Compressor

These Direct Drive oil-free compressors are built of quality materials to ensure trouble free use and can be run on a normal 240V domestic supply. Robust in manufacture, they all come with a pressure cut-off switch, fully automatic stop/start control, tank and line pressure gauges and an air outlet regulator. Robust 2hp direct drive motor producing an 8bar/115psi working pressure and an air supply of 8cfm/230ltr/min which is enough to run most air tools.



MOTOR 2.0hp
RECEIVER 46ltr

Product Number	Motor	Maximum Delivery	Maximum Pressure	Receiver Size	Order Code KBE-273	Price/1 TB
CNL246	2.0hp	8.0cfm	8bar	46ltr	-1100K	22693.00

OSAKI POWER TOOLS *High Pressure Washers*

For easy cleaning of vehicles, patios and other light duty applications. Compact and portable design with 5m length high pressure hose and trigger gun. Automatic on/off. Adjustable lance nozzle for fan or open jet wash pattern and an attachable soap dispenser bottle. Comes with 5m length of power cord.

HPW090
Power: 1.5kw.
Max rated pressure: 90bar.
Max water flow: 360ltr/hr.
Dimensions (L x W x H):
 290 x 330 x 610mm.

FOR DIY USE
 Not suitable for Industrial Use

90 BAR



NEW



Product Number	Weight each	Order Code	Price/1 TB
HPW090	12.14kg	OSA-279-9610K	6386.00

Accessory Kit



To suit: **OSA-279-9610K, OSA-279-9620K.**

Kit contents:
 wash brush, rotating head brush, water hose, pipe cleaning hose, tap connection coupling, hose coupling and turbo lance.

Product Number	Weight each	Order Code	Price/1 TB
PWA010	2.1kg	OSA-280-1705W	3021.00

HPW110
Power: 1.8kw.
Max rated pressure: 110bar.
Max water flow: 360ltr/hr.
Dimensions (L x W x H):
 290 x 330 x 1065mm.

110 BAR

NEW

Winding Handle



Product Number	Weight each	Order Code	Price/1 TB
HPW110	14.6kg	OSA-279-9620K	7725.00

Spare Parts

To suit: **OSA-279-6100K, OSA-279-6110K, OSA-279-9610K, OSA-279-9620K.**

Spare Parts:
 Replacement lance and trigger assembly.
 Replacement 5m high pressure hose.

Description	Order Code	Price/1 TB
Lance & Trigger Assembly	OSA-280-1701W	823.00
Long Hose	OSA-280-1702W	683.00

OSAKI LAWN AND GARDEN *Submersible Water Pump*

WPS 400
 Suitable for the effective drainage of cellars, cisterns and the general transfer of water. Can handle solids up to 5mm diameter. Easy to remove filters for cleaning and access to the impeller. Automatic float switch. Strong double insulated case. Multi-hose adaptor-accepts 25 or 32mm outlet hoses. Overload protection.

Motor: 400W (230V - 50Hz).
Max. flow rate: 7,500ltr/hr.
Max. delivery height/submersible depth: 5m.



400 WATT
230V

Model Number	Order Code	Price/1 TB
WPS 400	OSA-279-0560K	3348.00

KOBE *Submersible Water Pump*

WPS 750
 Suitable for the effective draining of cellars, cisterns and the general transfer of water. Capable of continuous and reliable running, strong double insulated case with no metal parts are in contact with the water. Overload protection and easy to remove filters for cleaning and access to the impeller. Fitted with an automatic float switch and a multi hose adaptor (25, 32, 38mm), can handle solids up to 5mm diameter.

Motor: 750W.
Maximum delivery height: 8.5m.
Power cable: 10m.
Flow rate: 230ltr.



750 WATT
240V

Model Number	Order Code	Price/1 TB
WPS 750	KBE-279-4470K	3570.00

PRODUCTS ARE ONLY AVAILABLE VIA YOUR DISTRIBUTOR

ABRASIVES & POWER TOOLS

GROUP 279 **DIY POWER TOOLS**



Multi Purpose Power Tool

219-Piece

The multi-tool includes a 1.1m flexible drive making it ideal for small DIY and craft jobs such as drilling, polishing, grinding and engraving. Complies with EN regulations and EC directives for CE certification.

Accessories include: 219 piece kit including grinding wheels, mounted points, carbide burrs, sanding bands, wire wheels and more.
1.1m flexible extension shaft.

Nominal voltage: 230V ~ 50Hz.

Power consumption: 130W.

No load speed: 8,000 - 30,000rpm.

Noise: 82db(A).

Weight: 674g.



Model Number	No Load Speed (rpm)	Power Input	Order Code	Price/1 TB
MP32E	8,000 - 30,000	130W	-8510K	3605.00

Electric Engraver Kit



Electric hand held engraver with positive on/off switch and five position stroke adjuster for varied engraving depths. For use on metals, plastics, glass, ceramics, wood and leather.

- Soft grip.
- 1.8m cable.
- Includes two tips and template for letters and numbers.



NEW

FOR DIY USE
Not warranted for Industrial Use

Model Number	Order Code	Price/1 TB
ENG003	-9810K	1500.00

Replacement Tips

Supplied as a packet of 5.

Pack Quantity	To suit	Order Code	Price/1 TB
5	ENG003	-3100A	361.00

250mm Sliding Compound Mitre Saw

MS254

Supplied with a 30T blade as standard plus an extra 60T blade for fine cutting. The powerful 1,900W motor, 5,300rpm blade speed, electric brake, laser cutting guide and auto return blade guard for safety make this saw amazing value for money. Its positive locking mechanism for quick selection of pre-set mitre angles and manual clamping for angles in between make it easy to work with. It can bevel up to 45° to the left and mitre up to 45° to the left or right. It also has a spindle lock, blade wrench and hexagon key for changing blades, spare brushset, dust bag and manual.

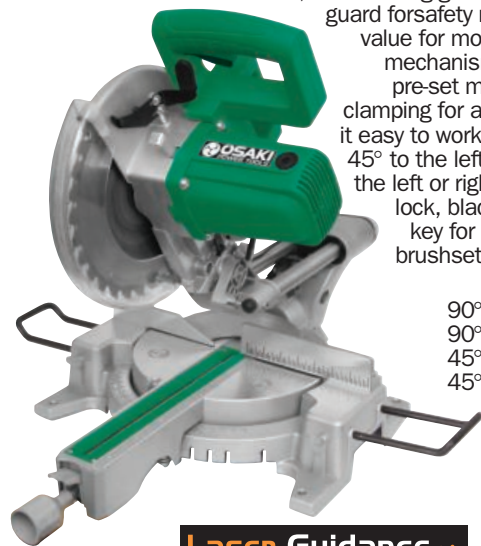

1900 WATT

EXTRA BLADE INSIDE

Cutting capacity:
90° x 90° - 70 x 310mm.
90° x 45° - 70 x 210mm.
45° x 90° - 40 x 310mm.
45° x 45° - 40 x 210mm.

Voltage	Weight each	Order Code	Price/1 TB
240V	1.90kg	-4780K	10970.00

Laser Guidance

Wood Planer 82mm

PWE910

This robust wood planer has adjustable cutting depth for precise material removal. Supplied with a spare set of twin TCT blades, parallel guide, rebating shoe and a dust collecting bag.

Input power: 910W.

Voltage: 240V.

No load speed: 15,000rpm.

Planing depth: 3mm.



910 WATT

EXTRA BLADE INSIDE

Model Number	Order Code	Price/1 TB	Description	Order Code	Price/1 TB
PWE910	-9100K	3031.00	Spare Blades	-1770A	98.00

185mm Circular Saw

SC185

Laser guidance for precision cutting. Low weight, durable magnesium alloy gear housing. Smooth running 1,350W motor, 230 - 240V/50Hz supply.



1350 WATT

Cutting capacity:
@90° 62mm/
@45° 43mm.
Supplied with:
two carbide-tipped blades 24T and 40T fine blade. Soft grip handle.

Laser Guidance

EXTRA BLADE INSIDE

Voltage	Weight each	Order Code	Price/1 TB
240V	4.20kg	-3650K	4654.00

2000W Hot Air Gun Kit

HG2000-2

Overheating protection. Can be positioned on a work surface facing upwards for hands free use. Air intake with 'hit and miss' air vent to keep out foreign matter. Useful for soldering, welding PVC, shaping, drying, shrink-fitting, stripping paint, removing sticky labels, drying wet timber prior to filling, etc. Supplied with accessories and moulded case.

Working temperature: 450 - 600°C.

Rating voltage: 220 - 240V - 50Hz.

Input power: 2,000W.

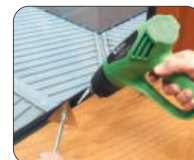

Model Number	Order Code	Price/1 TB
HG2000-2	-9600K	1853.00



**3.6V
Screwdriver**

CS36Li

Suitable for DIY, home improvement and for workshop use, its compact design allows you to get into tight spaces and it weighs only 350g. Powered by a high capacity lithium-ion battery with three colour LED battery condition lights, it has an ergonomic bi-material grip for comfort. The seven torque settings, forward/reverse/spindle lock and integral three LED worklight make it a versatile tool, ideal for kitchen/bedroom fitters etc.



Battery Condition Indicator

Voltage	Weight each	Order Code	Price/1 TB
3.6V	350g	OSA-279 -7100K	2165.00



3.6V
Li-Ion

13mm Impact Drill

IDH013

Suitable for DIY and hobby use. Variable speed forward and reverse. Heavy duty two speed gearbox. Switches easily from rotary to impact action. Locking side handle with integral metal depth stop.

Power input: 1,050W (230 - 240V).

No load speed: 0 - 1,100/3,000rpm.

Chuck capacity: 13mm.

Capacities: wood 30mm, steel 13mm, concrete 16mm.

Overall size (H x W x D):

360 x 260 x 100mm.

1050W

Model Number	Weight each	Order Code	Price/1 TB
IDH013	3.40kg	OSA-279 -9660K	4119.00



Group 595



1050
WATT

Rotary or hammer action

Heavy duty two speed gear box

Tile Cutter

TC08-450

Suitable for DIY and hobby use. Designed for cutting porcelain, glazed ceramic, slate, quarry and natural stone tiles. It features a 450W - 240V electric motor, 180mm continuous rimmed diamond cutting blade, 45° cutting guide, and a 3.5ltr capacity water reservoir. Safety features include blade guard, thermal overload protection and magnetic, VDE-approved safety switch.

450
WATT

NEW



No-volt release switch

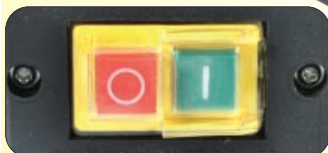

0° to 45° tilt for angled cuts



Motor	Voltage	Order Code	Price/1 TB
450W	240V	OSA-279 -8760K	4635.00

150mm/6" Bench Grinder - 250W

BG03-150-1

This electric bench grinder has a smooth running 250W motor, adjustable work support and spark deflectors/eye shields. It takes 150 x 20 x 12.7mm wheels and is supplied with a 36 grit wheel on the left and 60 grit wheel on the right.

250
WATT



FOR DIY USE
Not warranted for Industrial Use

Motor	Weight	Order Code	Price/1 TB
250W	7.5kg	OSA-279 -8000K	3089.00

ABRASIVES & POWER TOOLS

KOBE Multi Purpose Tool Kit

MPTK130EK

Cushion grip body. Six position speed dial. Spindle lock button. Fitted with a quick change collet nut system. Ideal for a wide range of smaller DIY and craft jobs as an alternative to larger power tools. Supplied in a fitted aluminium case.



Accessories included:
Flexible rubber drive shaft:

for use where maximum flexibility is required, to improve access in confined spaces. Bench clamp and tool steady.

118 Piece Accessory Kit Includes: various collets, cutters, drills, abrasives, brushes, burrs, wheels, discs and mandrels.

Bench Clamp & Tool Steady:

To fix tool steady to a work bench or table to hold the multi tool in place when using the flexible drive shaft.



Model Number	No Load Speed (rpm)	Power Input	Weight each	Order Code	Price/1 TB
MPT130EK	8,000 - 30,000	130W	640g	-2200K	4790.00

Description	Order Code	Price/1 TB
Flexible Drive	-4800K	578.00
Tool Stand	-4810K	433.00

Multi-Tool Accessory Kit

Fitted plastic case containing 53 piece multi-tool kit for a range of surface cleaning and polishing tasks.

Contents:

1x silicon carbide sanding wheel with 1/8" diameter shank,
1x aluminium oxide sanding wheel with 1/8" diameter shank,

1x holder 1/4" x 1/2", 1x holder 1/2" x 1/2",
1x mandrel shank diameter: 1/8",
1x nylon end brush,
1x wire cup brush,

2x grinding wheel 1/8" x 13/16",
30x cutting disc 1/32" x 15/16",
6x sanding band 1/2" x 1/2",
8x sanding band 1/4" x 1/2".

NEW

**53
PIECES**



Number of Pieces	Order Code	Price/1 TB
53	-3380K	599.00



KOBE Multi Tool Accessories

Suitable for use with KOBE, DREMEL and OSAKI Multi Tools.

Diamond Coated Burrs

Use with 3.2mm (1/8") 3 jaw collet.

Style & Diameter (mm)	Order Code KBE-280	Price/1 TB
Cylindrical 10.0	-3232K	78.00
Ball 2.4	-3234K	78.00



Flat Cut-off Wheels

Flat Cut-off in packs of 20.

Diameter (mm)	Order Code KBE-280	Price/Pk TB
Reinforced		
32	-3237K	88.00
Non-reinforced		
24	-3238K	57.00
32	-3239K	102.00

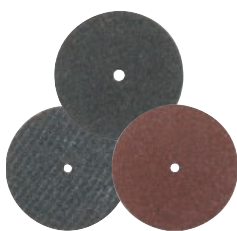

Wire Brushes

For the removal of paint, rust and burrs.

Type & Shape	Diameter x Length	Order Code KBE-280	Price/1 TB
Steel Cup	20 x 10	-3326K	68.00
Brass Cup	20 x 10	-3329K	98.00
Steel Wheel	19 x 1.2	-3332K	48.00
Bristle Wheel	19 x 1.2	-3335K	58.00
Bristle Flat End	3.2 x 9	-3338K	38.00



Mandrel

Product Number	Shank Dia.(mm)	Order Code KBE-280	Price/1 TB
M2	3.2	-3370K	47.00



Replacement 3 Jaw Collets

Suits Kobe and Osaki Multi Tools.

For Shank Size (mm)	Order Code KBE-280	Price/1 TB
1.6	-3361K	27.00
2.4	-3362K	38.00
3.2	-3364K	58.00



Collet Nut Wrench

Suits Kobe and Osaki Multi Tools.

AF Size	Order Code KBE-280	Price/1 TB
10mm	-3366K	27.00



Mounted Points & Wheels

3mm shank. 'W' numbers are for Wheels (for flat surface grinding). 'B' numbers are for points (Shaped for contour grinding).

Shape Number	Diameter x Length	Order Code KBE-280	Price/1 TB
B52	10 x 18	-3253K	27.00
W193	16 x 10	-3256K	21.00



Grey Silicon Carbide

Use on stone, glass, ceramics and non-ferrous metals.

Shape Number	Diameter x Length	Order Code KBE-280	Price/1 TB
B53	8 x 15	-3283K	26.00
B121	12 x 12	-3286K	26.00



Pink Al-ox

For use on harder metals where greater precision is required (lower stock removal rate).

Shape Number	Diameter x Length	Order Code KBE-280	Price/1 TB
B44	6.5 x 10.5	-3262K	21.00
B54	6.35 x 13.5	-3265K	21.00
B83	10 x 6.5	-3268K	21.00
B1222	9.8 x 9.8	-3271K	27.00
W164	6.35 x 14	-3274K	19.00
W173	10 x 3.2	-3277K	19.00
W193	16 x 10	-3280K	26.00



Green Silicon Carbide

For applications requiring a harder abrasive offering greater precision and durability (lower stock removal rate).



Diameter (mm)	Diameter x Length	Order Code KBE-280	Price/1 TB
W164	6 x 12	-3292K	19.00
W173	10.5 x 3	-3301K	27.00
W181	13 x 1.5	-3289K	22.00



Grinding Wheels

Silicon carbide: for use on stone, ceramics and non-ferrous metals.

Pink Al-ox: high hardness, use on metals.

White Al-ox: free cutting, use on metals.

Diameter (mm)	Diameter x Length	Order Code KBE-280	Price/1 TB
20	Silicon Carb.	-3244K	48.00
	Pink Al-ox	-3247K	48.00
	White Al-ox	-3250K	48.00



Polishing Wheel

Impregnated with silicon carbide. Use with spindle shown below

Diameter x Width (mm)	Order Code KBE-280	Price/1 TB
22 x 3	-3311K	42.00

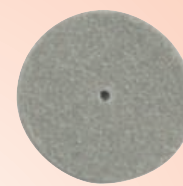

Felt Polishing Bobs

For use with polishing compounds to produce a high finish. Use with spindle shown below.

Shape	Diameter x Length	Order Code KBE-280	Price/1 TB
Cone	10 x 20	-3321K	47.00
Wheel	12.5 x 6	-3322K	38.00
Wheel	25 x 6.5	-3323K	48.00



Spindle

To suit above, taper screw.



Product Number	Shank Dia.(mm)	Order Code KBE-280	Price/1 TB
M1	3.2	-3371K	47.00

Sanding Bands

Al-ox abrasive for shaping and smoothing wood and fibreglass and removing rust. Quick change, use with holders shown below.

Supplied in packs of 10.

Diameter x Length	Grit Size	Order Code KBE-280	Price/Pk TB
10 x 12.5	P60	-3345K	158.00
10 x 12.5	P120	-3347K	158.00
12.5 x 12.5	P60	-3349K	185.00
12.5 x 12.5	P120	-3351K	185.00



Holders

Diameter x Length	Shank Size	Order Code KBE-280	Price/1 TB
10 x 12.5	3	-3359K	132.00
12.5 x 12.5	3	-3360K	143.00



ABRASIVES & POWER TOOLS

KOBE 18V 2-Speed Cordless Combi Drill

DDH180

Lightweight and well-balanced with a soft grip design, this drill has a built in LED light, 13mm keyless chuck, hammer-drill/drill-driver mode selection collar and 20 stage torque adjustment collar. The variable speed with electric brake and reversible control switch gives it maximum versatility in driver mode.

No load speed: 0 - 400/0 - 1,400rpm.

Max torque: 35Nm.

Blows per minute: 21,000bpm.

Drilling capacity: mild steel 13mm, softwood 28mm, concrete 13mm.

Batteries: 2x 1.5Ah, 18V DC.



Spare Battery & Charger

Model Number	Weight each	Order Code KBE-279	Price/1 TB	Item	Order Code KBE-280	Price/1 TB
DDH180	4.05kg	-0090K	16995.00	18V Li-Ion	-5790K	5408.00
				18V Charger	-5840M	2761.00

10.8V Drill Driver & Impact Driver Cordless Twinpack

Lightweight, high impact, heavy duty and compact design with built-in LED light and ergonomic, soft grip handles. Ideal for applications in tight spaces. 30 minute charging time. Twinpack contains 10.8V Cordless Drill Driver and Impact Driver with 2 Li-Ion battery packs and 1 battery charger. Supplied in carry case with shoulder strap.



NEW



Spare Battery & Charger

Item	Order Code KBE-279	Price/1 TB	Item	Order Code KBE-280	Price/1 TB
10.8V Drill/Driver	-0070K	8999.00	10.8V Li-Ion 1.5Ah	-9300K	1650.00
			10.8V Charger	-9310K	1999.00

KOBE Variable Speed Impact Driver

AID14.4

Soft grip design. Quick release. Integral battery level indicator. Heavy duty motor and gearbox. High impact speed.

- No load speed: 0 - 2,300.
- Rated impact rate: 0 - 3,000bpm.
- Maximum torque (kg-fcm): 1,300.
- Screwing capacity:
- Mechanical screws: M4 - M8.
- Standard screws: M5 - M12.
- High tension screws: M5 - M10.
- Batteries: 2x 1.3Ah NiMH.
- Charge time: 1hr.



- 14.4V NiMH
- 130 Nm
- x2
- 1HR

1/4" HEX FOR DIRECT DRIVE

Model Number	Weight each	Order Code KBE-279	Price/1 TB
AID14.4	1.60kg	-0600K	13905.00

Spare Battery & Charger

Item	Order Code KBE-280	Price/1 TB
14.4V, 1.3Ah NiMH	-2024W	2977.00
230V Charger	-5903A	2730.00

Variable Speed Cordless Impact Wrench

AIW14.4V

This quality industrial tool is lightweight and well balanced. Soft grip design, 1/2" square final drive. Forward/reverse. Integral battery level indicator. Heavy duty motor and gearbox and variable speed trigger, high impact speed.

- No load speed: 0 - 2,300rpm.
- Maximum torque: 1,300kg-fcm.
- Impacts per minute: 0 - 3,000ipm.
- Batteries: 2x 1.3Ah NiMH.
- Charge time: 1hr.



- 14.4V NiMH
- 130 Nm
- x2
- 1HR

1/2" SQUARE FOR POWER SOCKETS

Model Number	Weight each	Order Code KBE-279	Price/1 TB
AIW14.4V	1.75kg	-0660K	14935.00

Spare Battery & Charger

Item	Order Code KBE-280	Price/1 TB
14.4V, 1.3Ah NiMH	-2024W	2977.00
230V Charger	-5903A	2730.00

Impact Driver

AIL7.2LI

Compact and lightweight design allows you to get into tight spaces. Powered by a high capacity lithium-ion batteries. Rubber grip. Impact drive. Quick release 1/4" hexagon chuck. Forward and reverse. LED work light.

- Complete with:**
 carrying case, charger, 4x hexagon screwdriver bits, 1x 1/4" hexagon to 3/8" square drive adaptor, 5x hexagon shank drill bits.



Model Number	Weight each	Order Code KBE-279	Price/1 TB
AIL7.2LI	0.80kg	-4020K	5547.00



- 7.2V Li-Ion

ABRASIVES & POWER TOOLS

KOBE Angle Grinders

700W motor. Aluminium alloy gear housing. Slim low profile body design for easy use and access. Multi-position side handle. Disc guard can be turned 60°. Spindle locking device. Disc not included.

Rated voltage: 240V.
Frequency: 50Hz.
No load speed: 11,500rpm.



EXTENDED RANGE

Model Number	Disc Size	Spindle Thread	Order Code	Price/1 TB
KAG 100	100	M10	-1420D	4119.00
KAG 115	115	M14	-1420G	4100.00

'Combi-Sand' Belt & Disc Sander

Light enough to be semi-portable, yet its robust construction makes it ideal for workshop use. It has a disc sanding table suitable for finish sanding and curve sanding. The disc table also tilts to 45° for bevel sanding and when used with the mitring guide is ideal for sanding compound angles. The sanding belt is ideal for flat surface sanding but tilts up to 90° for end sanding. Can be directly connected to dust extraction (highly recommended) by way of the 61mm outlet port on the end of the sander.

Power input: 370W.
Sanding disc: 150mm PSA (Stikit).
Sanding belt: 100 x 914mm (4" x 36").

370 WATT



Model Number	Weight each	Order Code	Price/1 TB
SBD370	17.0kg	-4140K	10281.00



Group 230



Group 235

Bench Grinders

Industrial quality, for the professional user. Adjustable tool rest and spark deflector. Maintenance-free motor. Eye shield. Smooth and quiet operation. CE approved.

150mm
Voltage: 240V.
Speed: 2,800rpm.
Maximum grinding wheel width: 25mm.
Spindle diameter: 15mm.



385 WATTS



Supplied with 2 York Grinding Wheels: A36 & A60

Voltage	Weight each	Order Code	Price/1 TB
240V	11.0kg	-1060K	7725.00

200mm
Voltage: 240V.
Speed: 2,800rpm.
Maximum grinding wheel width: 25mm.
Spindle diameter: 15mm.

385 WATTS



Supplied with 2 York Grinding Wheels: A36 & A60

Voltage	Weight each	Order Code	Price/1 TB
240V	21.2kg	-1080K	9199.00

Pedestal & Wall Mounted Bench Grinder Stands

Four point fixing suitable for securely fixing bench grinders to the wall or floor. Manufactured from heavy gauge steel, all welded construction painted finish. Each mounting plate can accommodate various sizes of grinder base.

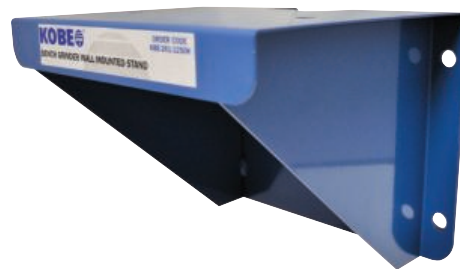

Description	Order Code	Price/1 TB
Pedestal Stand	-1220K	6494.00
Wall Mounted Stand	-1250K	3863.00

KOBE Belt & Disc Sander

KBDS230

Semi-portable and bench mounting, making it ideal for use in joiners and carpenters' workshops. For sanding hard and soft woods, most plastics and non-ferrous metals. Suitable for bevel sanding, flat surface sanding, end sanding and curved edge sanding. Tilting worktable (0 - 45°) and adjustable horizontal angle guide.

Power input: 250W.

Voltage: 230V.

Belt size: 25 x 762mm.

Disc size: 125mm diameter.

2x dust extraction outlets.

Supplied with: 1x 125mm P80 sanding disc, 1x 25 x 762mm P80 sanding belt.



NEW

250 WATTS

125 mm

Belt & Disc Sander

KSS406

High performance scroll saw suitable for home woodworking and model making projects, pattern makers and technical colleges. Rigid construction eliminates vibration in use. Variable speed motor gives ultimate control regardless of the material being cut. Features a 405mm throat capacity, and variable cutting speed range from 550 to 1600spm. Parallel arm design ideal for cutting curves. Dust blower to keep work area free of sawdust. Table can be adjusted 0 - 45°. Adjustable safety guard and drop foot. Cast iron base.

Variable speed: 550 - 1,600SPM.

Max cutting length: 405mm.

Max cutting depth: 50mm.

Stroke: 20mm.

Table size: 415 x 255mm.

Supplied with:

pinless blade adaptors, blades: 1x 133 x 3mm x 15TPI and 1x 133 x 2mm x 18TPI.

250 WATTS

VARIABLE SPEED

NEW



Voltage	Weight each	Order Code	Price/1 TB
230V	7.36kg	KBE-271 -4150K	6999.00

File Belts to Suit

Suitable for a wide range of power tools. Aluminium oxide designed for a wide range of materials including metal, steel, aluminium and non-ferrous metals.

Size W x L:

25 x 760mm



Grit	Order Code	Price/1 TB
P36	-5100K	5665.00
P60	-5130K	5665.00
P80	-5140K	5665.00

Adhesive Backed Discs to Suit

A range of adhesive backed discs - plain.



Size (mm)	Grit	Order Code	Price/1 TB
	P40	-0008A	499.00
	P60	-0009A	499.00
125	P80	-0010A	499.00
	P120	-0011A	499.00

Voltage	Weight each	Order Code	Price/1 TB
230V	11.5kg	-8520K	6250.00

ABRASIVES & POWER TOOLS

Wet & Dry Vacuum Cleaner & Blower

Lightweight, compact and portable design with powerful 1,200W two stage motor. Vacuums up dirt, debris and liquid. Low noise model with 30 litre capacity and safety shut-off for wet operation.

Supplied with:

2 metre vacuum hose, 2x aluminium extension pipes, 32mm brush tool, squeegee tool, round brush tool, crevice tool, paper filter cartridge, cylinder for wet vacuuming and 11 litre fleece vacuum bag.

1200 WATTS

30 ltr

NEW



Filter



Voltage	Weight each	Order Code	Price/1 TB
230V	11.0kg	KBE-279 -3140K	16500.00

Wet & Dry Vacuum Cleaner

Suitable for industrial and commercial use. Two powerful motors, 1,200W and 2,400W for superior performance in cleaning large areas. Portable design with swivel stainless steel drum for easy emptying of waste and liquids. Trolley with two front swivel castor wheels for ease of movement and two large rear fixed wheels for enhanced stability.

Supplied with:

3 metre vacuum hose, 2x stainless steel extension pipes, 38mm brush tool, crevice tool, squeegee tool, round brush tool, crevice tool, paper filter cartridge for dry vacuuming and cloth filter for wet vacuuming.

2400 WATTS

1200 WATTS

55 ltr

NEW



Vacuum bag connector



Voltage	Weight each	Order Code	Price/1 TB
230V	25.5kg	KBE-279 -3170K	29000.00

PRODUCTS ARE ONLY AVAILABLE VIA YOUR DISTRIBUTOR

GROUP 280 SANDING & POLISHING PADS



Flexible Backing Pads for Velcro Sanding Discs



Suitable for use with Kennedy Hook-n-Loop and other 'velcro-type' sanding discs.

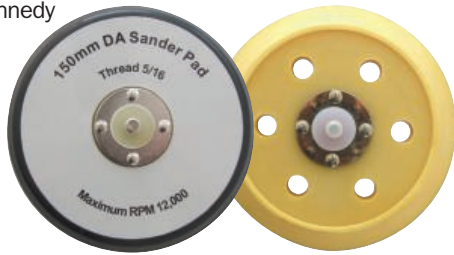

To Suit Disc	Thread Size	Hole Configuration	Order Code KEN-280	Price/1 TB
115mm	M14 x 2.0	No Hole	-3110K	979.00
125mm	M14 x 2.0	No Hole	-3230K	1005.00
	5/8" UNC	No Hole	-3210K	1005.00
150mm	M14 x 2.0	No Hole	-3330K	1288.00
	5/8" UNC	No Hole	-3310K	1288.00
	5/16" UNF Male	No Hole	-3370K	1029.00
	5/16" UNF Male	6 Hole	-3390K	1029.00

Flexible Backing Pads

Suitable for use with all portable and air disc grinders and sanders. Recommended for use with York abrasive discs.



To Suit Disc	Thread Size	Order Code KEN-280	Price/1 TB
100mm	M10 x 1.25	-2010K	411.00
	M10 x 1.5	-2030K	411.00
	3/8" UNF	-2050K	411.00
115mm	M10 x 1.5	-2110K	420.00
	M14 x 2.0	-2130K	420.00
125mm	5/8" UNC	-2210K	563.00
	M14 x 2.0	-2230K	563.00
	5/8" UNC	-2310K	1029.00
178mm	M14 x 2.0	-2330K	1029.00
	5/8" UNC	-2350K	1029.00
	Quick Release M14 x 2.0	-2370K	1029.00

Flexible Backing Pads for Self-Stick Sanding Discs

Designed for use with orbital sanders



To Suit Disc	Thread Size	Hole Configuration	Order Code KEN-280	Price/1 TB
150	5/16" UNF	No Hole	-3870K	1029.00
	5/16" UNF	6 Hole	-3920K	944.00

Tie Cord Bonnet Support Pads



High quality 23mm foam pads with rigid back plates. For use with all tie cord bonnets. Bonnets supplied separately. Max. 2,500rpm.



*125mm and 150mm pads are dual purpose - also for use with Velcro bonnets or foams.

Bonnet Dia. (mm)	Thread Size	Order Code KEN-280	Price/1 TB
125*	M14 x 2 5/8" UNC	-3230K	1005.00
150*	M14 x 2	-4030K	1288.00
180	M14 x 2	-2420K	1015.00
	5/8" UNC	-4020K	904.00

Sheepskin Bonnets

Genuine 100% natural long lasting sheepskin tie-on bonnets for professional use. For polishing metal, glass fibre, wood and painted surfaces. With tie cord. Maximum 2,500rpm - Best results are obtained with a tool speed of 1,500 - 2,000rpm. Not suitable for wet use. Support pads supplied separately, see below.



Merino Sheepskin Bonnets

With a unique double skin making this the longest lasting bonnet we know. For professional use. 32mm pile.

Diameter (mm)	Thread Size	Order Code KEN-280	Price/1 TB
150	55g	-5020K	666.00
180	60g	-3900K	773.00
225	60g	-3905K	943.00

Fabric Backed Lambs Wool Bonnets

Natural fabric backed wool bonnet. Ideal for use on surfaces of all colours. 20mm pile.



Diameter (mm)	Weight each	Order Code KEN-280	Price/1 TB
178	50g	-3910K	567.00

KOBE Sanding Discs

Hook-n-Loop Backed

No spanners required. 100% of disc can be used, material removal rate is therefore increased. Can be repeatedly removed and re-applied. Silicon carbide abrasive especially suitable for automotive body preparation prior to spraying and for cutting back two-pack paint finishes. Can be used wet or dry.



Disc Diameter	Grade	Pack Quantity	Order Code KBE-280	Price/Pk TB
50mm (2")	320	25	-0203A	504.00
	400		-0204A	504.00
	600		-0205A	504.00
75mm (3")	320	25	-0206A	921.00
	400		-0207A	921.00
	600		-0208A	921.00

Flexible Backing Pads for Velcro Sanding Discs

For use with Kobe Hook-n-Loop and other 'velcro-type' sanding discs, for rapid abrasive disc changing.



To Suit Disc	Thread Size	Order Code KBE-280	Price/1 TB
50mm	M6	-0201A	882.00
75mm		-0202A	882.00

KENNEDY *Buffing & Polishing Foams*
QUALITY INDUSTRIAL TOOLING

A range of professional polishing foams for use with all makes of power tools. Offers a complete surface finishing solution. All pads are 150mm diameter x 50mm deep.



White Compounding Foam

Excellent results with all leading makes of compound and polish. Very firm material, ideal for all modern paints including LVHM.

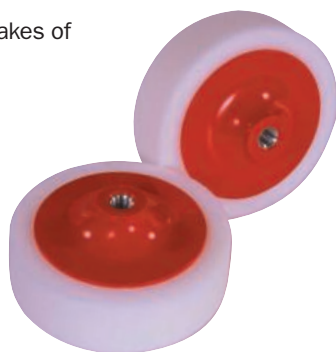

Diameter (mm)	Thread Size	Order Code KEN-280	Price/1 TB
150	M14 x 2 5/8" UNC	-5260K	778.00
		-5280K	763.00

Blue Regular Compounding Foam

Softer, all purpose foam for polishing and compounding of cellulose and acrylic. With a medium density grade.

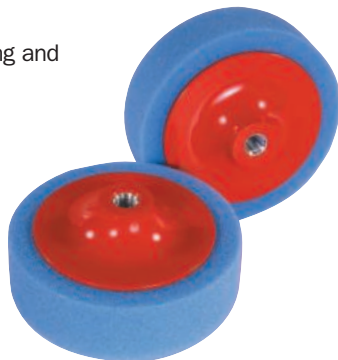

Diameter (mm)	Thread Size	Order Code KEN-280	Price/1 TB
150	M14 x 2 5/8" UNC	-5300K	755.00
		-5320K	763.00

Red Final Polishing Foam

Ultra soft reticulated foam for final polishing/finishing. Designed to allow free flow of air.



Diameter (mm)	Thread Size	Order Code KEN-280	Price/1 TB
150	M14 x 2 5/8" UNC	-5380K	755.00
		-5400K	755.00

CIRCULAR SAW BLADES

KOBE *Circular Saw Blades*

NEW



HSS TCT circular saw blade for precision ground cutting angles on softwood, hardwood, MDF, plywood etc. Excellent blade sharpness and faster cutting make it ideal for general purpose use on both corded and cordless circular saws.

Coarse Pitch

Ripping blades, with fewer teeth per inch (less TPI). Suitable for cutting long grain solid wood.

TCT

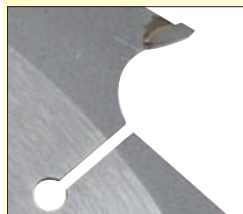

Size Dia. x Thickness x Bore	Blade Type	Order Code KBE-280	Price/1 TB
160 x 2.4 x 30mm	12T - Coarse	-5695K	747.00
190 x 2.4 x 30mm	12T - Coarse	-5698K	850.00
235 x 2.8 x 30mm	24T - Coarse	-5702K	1288.00

Medium Pitch

General purpose blades, with medium teeth per inch. For cutting both long grain and cross grain solid wood. These blades produce a good surface finish that requires less finishing.

TCT

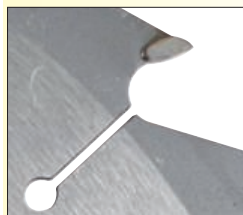

Size Dia. x Thickness x Bore	Blade Type	Order Code KBE-280	Price/1 TB
150 x 2.4 x 16mm	24T - Medium	-5711K	979.00
150 x 2.4 x 20mm	24T - Medium	-5712K	979.00
160 x 2.4 x 16mm	24T - Medium	-5713K	979.00
160 x 2.4 x 20mm	24T - Medium	-5714K	979.00
180 x 2.4 x 20mm	24T - Medium	-5715K	979.00
184 x 2.4 x 16mm	24T - Medium	-5716K	979.00
190 x 2.4 x 16mm	24T - Medium	-5717K	979.00
190 x 2.4 x 30mm	24T - Medium	-5718K	979.00
200 x 2.4 x 30mm	30T - Medium	-5719K	1185.00
210 x 2.4 x 30mm	30T - Medium	-5720K	1236.00
230 x 2.8 x 30mm	34T - Medium	-5721K	1442.00
235 x 2.8 x 30mm	34T - Medium	-5722K	1442.00
250 x 2.8 x 30mm	40T - Medium	-5723K	1545.00

Fine Pitch

Perfect for cross cutting, with high teeth per inch. Suitable for cross grain cutting solid wood, producing a smooth surface that requires less finishing.

TCT

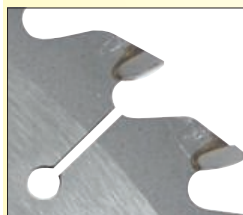

Size Dia. x Thickness x Bore	Blade Type	Order Code KBE-280	Price/1 TB
184 x 2.4 x 16mm	40T - Fine	-5736K	1339.00
190 x 2.4 x 16mm	40T - Fine	-5737K	1442.00
190 x 2.4 x 30mm	40T - Fine	-5738K	1442.00
216 x 2.4 x 30mm	64T - Fine	-5740K	2059.00
235 x 2.8 x 30mm	48T - Fine	-5742K	1803.00
250 x 2.8 x 30mm	60T - Fine	-5743K	1854.00

ABRASIVES & POWER TOOLS

GROUP 281 SOCKETS & CABLE REELS

KENNEDY 110V Open Drum Cable Reel
QUALITY INDUSTRIAL TOOLING

Polycarbonate drum and side walls. Arctic grade cable. Maximum load 16A/1760W. Conforms with **BS 5733**.

1.5mm² core cable.



Cable Length	Weight each	Order Code	Price/1 TB
40m	8.50kg	KEN-281 -2840K	4635.00

240V Site Extension - Square Pin

With fitted 240V/13A square pin plug and socket. Not suitable for use in wet conditions. Arctic grade cable. Conforms to **BS 4343 : 1968**.



Cable Length	Weight each	Order Code	Price/1 TB
3m	3.3kg	KEN-282 -2600K	2421.00

KOBE Twin Socket Drum Cable Reel

Twin socket 240V open drum industrial cable reel. Metal frame with built-in carry handle with winding handle built into the high impact resistant drum.

Rated: 3120W/13A unwound. 1680W/7A wound. 25m cable supplied complete with fitted plug. Conforms to **BS 1363** and **BS EN61242:2004**.



Type	Cable Length	Weight each	Order Code	Price/1 TB
Open Drum	25m	3.90kg	KBE-281 -1050K	2184.00

25m 110V Open Drum Cable Reel

Easy wind reel mechanism. High impact resistant drum and guide walls. 25m cable. Conforms to **BS 1363**.



Type	Cable Length	Weight each	Order Code	Price/1 TB
Open Drum	25m	4.40kg	KBE-281 -2500K	3354.00

Twin Socket Cable Reel

Twin socket, versatile 10m cable reel for home and office use. Fully enclosed cassette with built-in carry and winding handle. Fitted with a safety cut-out switch. Lifetime guarantee.

240V rated: 2400W/10A unwound 20W/3A wound. Conforms to **BS 5733**.



Cable Length	Weight each	Order Code	Price/1 TB
10m	1.9kg	KBE-281 -1010K	974.00

4 Socket Cable Reels

4 socket, 240V/13A versatile cable reels for home and office use. Fully enclosed cassette with built-in carry and winding handle. Conforms to **BS6500/1363A/EN61242**, fitted with a safety cut-out switch.



Cable Length	Weight each	Order Code	Price/1 TB
5m	1.2kg	KBE-281 -0060K	649.00
10m	1.7kg	-0070K	1236.00
15m	1.3kg	-0080K	1339.00

Site Plugs & Sockets

Rated to 16A over 6 hours.

Colour coded: 110V yellow, 240V blue. Conform to **BS 4343 : 1968**.

Sockets fitted with fully waterproof spring loaded caps.

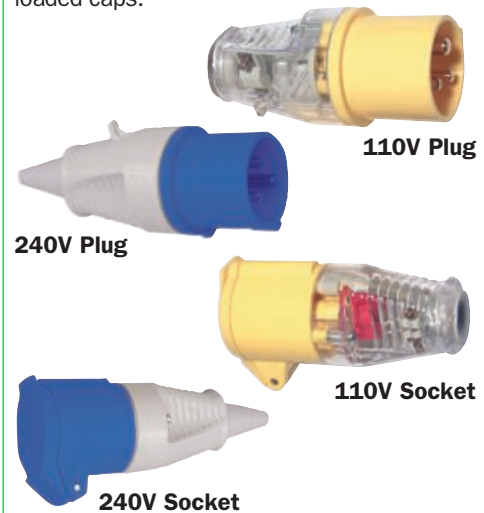

Voltage	Weight each	Order Code	Price/1 TB
3 Pin Plugs			
110V	110g	-1110K	155.00
240V	110g	-1115K	155.00
3 Pin Sockets			
110V	150g	-1120K	205.00
240V	150g	-1125K	222.00

240V Site Extension - Square Pin

With fitted 240V/13A square pin plug and socket. Not suitable for use in wet conditions. Arctic grade cable. Conforms to **BS 4343 : 1968**.



Voltage	Weight each	Order Code	Price/1 TB
240V	1.85kg	KEN-282 -2530K	1700.00

ABRASIVES & POWER TOOLS

Ingress Protection (IP) Ratings

Ingress Protection (IP) ratings are developed by the **European Committee for Electro Technical Standardization (CENELEC)** (described IEC/EN 60529), specify the environmental protection an enclosure provides. In order to comply with stringent requirements for **CE Marking**, machine makers today are fitting their machines with parts that are certified according to **EU (European Union)** and international standards.

The IP rating normally has two (or three) numbers:

- IP First Number**
Protection from solid objects or materials
- IP Second Number**
Protection from liquids
- IP Third Number**
Protection against mechanical impacts (commonly omitted)

Example - IP Rating



5 describes the level of protection from solid objects and
4 describes the level of protection from liquids.

1 Protection against solid objects

- 0 No protection.
- 1 Protected against solid objects up to 50mm, e.g. accidental touch by hands.
- 2 Protected against solid objects up to 12mm, e.g. fingers.
- 3 Protected against solid objects over 2.5mm (tools and wires).
- 4 Protected against solid objects over 1mm (tools, wire, and small wires).
- 5 Protected against dust limited ingress (no harmful deposit).
- 6 Totally protected against dust.

2 Protection against liquids

- 0 No protection.
- 1 Protection against vertically falling drops of water e.g. condensation.
- 2 Protection against direct sprays of water up to 15° from the vertical.
- 3 Protected against direct sprays of water up to 60° from the vertical.
- 4 Protection against water sprayed from all directions or limited ingress permitted.
- 5 Protected against low pressure jets of water from all directions - limited ingress.
- 6 Protected against low pressure jets of water, e.g. for use on ship decks - limited ingress permitted.
- 7 Protected against the effect of immersion between 15cm and 1m.
- 8 Protects against long periods of immersion under pressure.

3 Protection against mechanical impacts (commonly omitted)

- 0 No protection.
- 1 Protects against impact of 0.225 joule (e.g. 150g weight falling from 15cm height).
- 2 Protected against impact of 0.375 joule (e.g. 250g weight falling from 15cm height).
- 3 Protected against impact of 0.5 joule (e.g. 250g weight falling from 20cm height).
- 4 Protected against impact of 2.0 joule (e.g. 500g weight falling from 40cm height).
- 5 Protected against impact of 6.0 joule (e.g. 1.5kg weight falling from 40cm height).
- 6 Protected against impact of 20.0 joule (e.g. 5kg weight falling from 40cm height).

KENNEDY Portable Task Light

Using an energy saving 28W 2D fluorescent bulb that generates the same light as halogen but using far less energy. Tough poly-carbonate case and virtually shatterproof lens. Supplied with 3m rubberised mains lead. Ideal for all trades. **IP44 rated**



3m CABLE

Input Voltage	Weight each	Order Code	Price/1 TB
240V	1.52kg	KEN-282	2115.00

Mini-Pod Floodlight

With epoxy coated, non-tipping frame, fitted plug and halogen tube. Made from top grade components and wire for industrial, heavy duty use.



3m CABLE

Supplied with 500W halogen bulb and plug. **Maximum rating: 500W.** Replacement head units available on request.

Input Voltage	Wattage	Weight each	Order Code	Price/1 TB
240V	500W	2.5kg	-3820K	2059.00

Gripper Lamps

Clamp facility ideal for 'hands free' use. High strength metal clamp with rubber contact points. Glass bulb housing with sturdy plastic casing. 5m/16' cable length with fitted plug. CE approved. Bulb not included.



22m CABLE

Input Voltage	Bulb Fitting	Max Rating	Order Code	Price/1 TB
110V	Screw	60W	-3200K	1339.00
240V	Bayonet	60W	-3220K	1339.00

KOBE Rechargeable 108 LED Portable Floodlight

NEW

With 108 super bright LEDs, this portable floodlight is ideal for lighting garages, workshops and working environments where lighting is not available. Mounted on a steel frame with an adjustable head, it has a waterproof design which makes it suitable for indoor and outdoor use. Comes supplied with a Li-Ion rechargeable battery, mains AC adaptor and 12V in-car charger.



Battery	Order Code	Price/1 TB
12V	KBE-282	3863.00

Work Lights

400W tungsten halogen head fitted with 3m cable. Complete with tungsten halogen tube. Heavy duty aluminium telescopic tripod that extends from 0.7m to 1.74m. **IP54 rated.**

5m CABLE
EXTENDS TO 1.7m



Twin Head



Single Head

Input Voltage	Head Type	Order Code	Price/1 TB
240V	Single	-2830H	2575.00
240V	Twin	-2850H	3193.00

Spare Bulbs - Halogen

Suitable for use with all standard PIR lights, mini-pod floodlights, tripod site lights etc.



EXTENDED RANGE

Input Voltage	Wattage	Weight each	Order Code	Price/1 TB
240V	500W	15g	-3100K	134.00
110V	500W	15g	-3110K	134.00
240V	150W	15g	-3150K	99.00

GROUP 287 ROUTER CUTTERS

KENNEDY Router Cutters
QUALITY INDUSTRIAL TOOLING

Manufactured from high speed steel with tungsten carbide tips. Suitable for use with all portable routing machines. Ideal for both craft work and production. Suitable for light duty and workshop use.

Two Flute Straight Plunging Bits
General purpose tool suitable for profiling, rebating and through slotting. Plunge cut when on the move.



Cut Dia. x Cut Length x Overall Length	Weight each	Order Code KEN-287	Price/1 TB
1/4" Shank Diameter			
3.2 x 11 x 51mm	10g	-4100K	979.00
4.0 x 11 x 51mm	10g	-4120K	979.00
5.0 x 11 x 51mm	10g	-4160K	1082.00
6.0 x 19 x 51mm	10g	-4200K	1104.00
6.0 x 25 x 57mm	10g	-4220K	1210.00
8.0 x 19 x 51mm	12g	-4360K	999.00
12.0 x 25 x 57mm	25g	-4580K	1104.00
20.0 x 19 x 51mm	30g	-4840K	1681.00
25.0 x 19 x 51mm	40g	-4920K	1419.00
25.4 x 19 x 51mm	45g	-4940K	1419.00

Cut Dia. x Cut Length x Overall Length	Weight each	Order Code KEN-287	Price/1 TB
1/2" Shank Diameter			
6.0 x 19 x 63mm	45g	-5020K	894.00
12.0 x 25 x 67mm	60g	-5220K	1104.00
12.7 x 32 x 73mm	70g	-5260K	1050.00
12.7 x 51 x 108mm	80g	-5320K	1419.00
12.7 x 64 x 114mm	100g	-5340K	1787.00
16.0 x 32 x 73mm	70g	-5460K	1524.00
16.0 x 51 x 96mm	70g	-5500K	1997.00
22.0 x 32 x 73mm	90g	-5680K	1787.00
25.4 x 32 x 73mm	80g	-5740K	1629.00
32.0 x 32 x 73mm	140g	-5800K	2154.00

Two Flute Staggered Tooth Bits
Cutter for deep mortising and grooving. Staggered cutting edges give good chip clearance enhancing quality of cut.

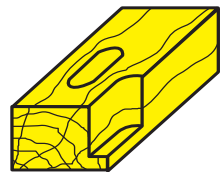

Cut Dia. x Cut Length x Overall Length	Weight each	Order Code KEN-287	Price/1 TB
3/8" Shank Diameter			
9.5 x 35 x 76mm	35g	-3160K	946.00

Single Flute Straight Plunging Bits
For cutting grooves/apertures and general shaping work. Single flute for maximum support behind the cutting edge, giving strength, while providing large clearance for ease of chip flow promoting fast free cutting.

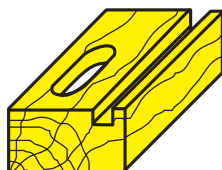

Cut Dia. x Cut Length x Overall Length	Weight each	Order Code KEN-287	Price/1 TB
1/2" Shank Diameter			
12.7 x 32 x 73mm	60g	-0080K	1104.00
12.7 x 38 x 80mm	65g	-0100K	1314.00

Cove Bits
With ball bearing guide. For edge mould on coving, picture frames etc.



Cut Dia. x Cut Length x Overall Angle	Weight each	Order Code KEN-287	Price/1 TB
1/4" Shank Diameter			
12.7 x 45mm x 90°	10g	-2480K	1067.00
19.0 x 51mm x 90°	15g	-2540K	1209.00

Two Flute Rabbeting Bits
For producing rebates. With ball bearing guide ensuring accurate depth of cut. Ideal for straight and curved work.



Cut Dia. x Cut Length x Overall Length	Weight each	Order Code KEN-287	Price/1 TB
1/4" Shank Diameter			
32.0 x 9.5 x 55mm	55g	-1160K	1839.00

SENATOR Router Cutters

Grooving Bits
For veining work and decor of panels.



Cut Dia. x Cut Length x Cutting Angle	Weight each	Order Code SEN-287	Price/1 TB
1/4" Shank Diameter			
12.7 x 40mm x 90°	10g	-7340K	655.00

Core Box Bits
For edge moulding, face grooving and fluting.



Cut Dia. x Cut Length x Radius	Weight each	Order Code SEN-287	Price/1 TB
1/4" Shank Diameter			
12.7 x 8 x 6.3mm	10g	-7240K	655.00

Rounding Over Bits
With ball bearing guide for panel and edge moulding.



Cut Dia. x Cut Length x Radius	Weight each	Order Code SEN-287	Price/1 TB
1/4" Shank Diameter			
28.6 x 17.0 x 9.5mm	40g	-7450K	2115.00

Two Flute Rounding Over Bits
For panel and edge moulding work, such as table tops and window boards. For use with template guide.



Cut Dia. x Cut Length x Radius	Weight each	Order Code KEN-287	Price/1 TB
1/4" Shank Diameter			
19.0 x 14.5 x 6.3mm	10g	-2640K	2207.00

Router Cutter Set

- Two Flute Core Box Bit:** 12.7mm diameter x 6.3mm radius.
- Two Flute Core Bit:** 22mm diameter x 6.3mm radius with ball bearing guide.
- Two Flute Dovetail Bit:** 12.7mm diameter x 14° side cutting angle.
- Two Flute Chamfering Bit:** 32mm dia. x 45° side cutting angle with ball bearing guide.
- Two Flute Flush Trimming Bit:** 12.7mm diameter with ball bearing guide.
- Two Flute Straight Trimming Bit:** 16mm diameter x 12.4mm cutting length.
- Two Flute Rounding Over Bit:** 22mm dia. 6.3mm radius with ball bearing guide.
- Two Flute Straight Trimming Bit:** 12mm diameter x 20mm cutting length.
- Two Flute Straight Trimming Bit:** 6mm diameter x 19mm cutting length.
- Two Flute Rounding Over Bit:** 28.6mm dia. x 9.5mm radius with ball bearing guide.
- Two Flute Dovetail Bit:** 12.7mm diameter x 90° inclusive cutting angle.
- Two Flute Roman Ogee Bit:** 25mm dia. x 14.5mm.

12 PIECES



TCT

Number of Pieces	Weight each	Order Code SEN-287	Price/1 TB
12	650g	-9000K	1571.00



KENNEDY *SDS Max*
QUALITY INDUSTRIAL TOOLING® **Chisels**

High grade forged-steel with shot-blast finish. Suitable for all tools with SDS Max system.

Moil Point - 500mm



Flat Breaker Chisel - 500 x 25mm



Wide Chisel - 400 x 50mm



Spade Chisel - 300 x 75mm

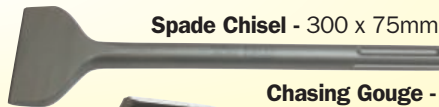

Chasing Gouge - 300 x 25mm

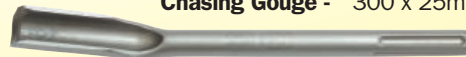

Type	Size (mm)	Weight each	Order Code KEN-289	Price/1 TB
Flat Breaker Chisel	500 x 25	1.0kg	-2720K	1005.00
Point	500 x 18 x 5	1.0kg	-2760K	1005.00
Wide Chisel	400 x 50	0.9kg	-2780K	1523.00
Spade Chisel	300 x 75	0.7kg	-2800K	1624.00
Chasing Gouge	300 x 25	0.7kg	-2820K	1318.00

Air Tool Chisels with 0.401" Shank

For all brands of portable air chisels including CP, Desoutter, Kobe, Toku and YK.

Flat Chisel - 178 x 15mm.



Smoothing Hammer - 75 x 25mm.



Rivet Cutter - 145 x 25mm.



Panel Cutter - 150mm.



Taper Punch - 180 x 3mm.



Straight Punch - 180 x 12mm.



Bushing Splitter - 180 x 12mm.



Spot Weld - 180 x 12mm.



Type	Weight each	Order Code KEN-289	Price/1 TB
Flat Chisel	150g	-1070K	642.00
Smoothing	100g	-2300K	393.00
Rivet Cutter	130g	-2350K	754.00
Panel Cutter	150g	-2400K	440.00
Taper Punch	150g	-2450K	723.00
Straight Punch	150g	-2500K	564.00
Bushing Splitter	170g	-2550K	564.00
Spot Weld	160g	-2600K	629.00

Power Tool Chisels

Hilti Style Chisels

For Hilti: TE54, TE72, TE92, TE504.

18mm Round Shank with Hilti Direct Fit Retainer.

Flat Chisel - 355 x 25mm.



Type	Weight each	Order Code KEN-289	Price/1 TB
Flat Chisel	700g	-1270K	749.00

Kango Style Chisels

For Kango: 501, 627, 628, 637, 638, 430 - Type 750 shanks.

19mm Hex Shank with Single Flat & Round Tang

Flat Chisel - 380 x 25mm.



Wide Chisel - 305 x 50mm/305 x 75mm.



Moil Point - 380 x 3mm.



Type	Weight each	Order Code KEN-289	Price/1 TB
Flat Chisel	800g	-1330K	610.00
Wide Chisel	700g	-1800K	868.00
Moil Point	730g	-1830K	973.00
	800g	-2000K	405.00

For Kango: 900K, 928, 950K, 978, 1400. Hitachi: DH38YD, DH50SA, H55SA. Makita: HM1200K, HR3850K.

21mm Hex Shank with Single Flat & Round Tang

Flat Chisel - 380 x 25mm.



Wide Chisel - 305 x 50mm/305 x 75mm.



Moil Point - 380 x 3mm.



Type	Weight each	Order Code KEN-289	Price/1 TB
Flat Chisel	1000g	-1350K	786.00
Wide Chisel	900g	-1640K	768.00
Moil Point	930g	-1670K	768.00
	1000g	-2030K	686.00

Makita Style Chisels

For Makita: HM0810, HR3500, HR3520, 8035NB.

17mm Hex Shank with Round Tang & Round Retainer Recess

Wide Chisel - 280 x 50mm.



Moil Point - 280 x 3mm.



Type	Weight each	Order Code KEN-289	Price/1 TB
Wide Chisel	530g	-1550K	816.00
Moil Point	430g	-1900K	462.00

Bosch Style Chisels

For Bosch: GBH7/45, UBH6/35, UBH12/50, USH6, 11202, 11203, 11204, 11206, 11208, 11209. AEG (Atlas Copco): PHD26, PH38, PHD38, PH240D, PH350D. Black & Decker: HD2032, HD2038, P8032, P8038.

19mm Hex Shank with Single Flat & Round Tang

Flat Chisel - 380 x 25mm.



Wide Chisel - 305 x 50mm/305 x 75mm.



Moil Point - 380 x 3mm.



Type	Weight each	Order Code KEN-289	Price/1 TB
Flat Chisel	880g	-1300K	639.00
Wide Chisel	780g	-1580K	809.00
Moil Point	830g	-1610K	907.00
	880g	-1970K	405.00

For Bosch: USH10, 11305, 12312.

19mm Hex Shank with Single Flat

Flat Chisel - 380 x 25mm.



Wide Chisel - 305 x 50mm/305 x 75mm.



Moil Point - 380 x 6mm.



Type	Weight each	Order Code KEN-289	Price/1 TB
Flat Chisel	900g	-1400K	548.00
Wide Chisel	820g	-1700K	768.00
Moil Point	900g	-2090K	1376.00

For Bosch: USH27, USH28, 11304, 11308, 12314

29mm Hex Shank with Single Flat

Flat Chisel - 380 x 31mm/455 x 25mm.



Moil Point - 380 x 6mm/455 x 6mm.



Type	Weight each	Order Code KEN-289	Price/1 TB
Flat Chisel	2.0kg	-1430K	1451.00
	2.4kg	-1480K	1571.00
Moil Point	2.0kg	-2060K	1191.00
	2.4kg	-2120K	1376.00

ABRASIVES & POWER TOOLS

GROUP 291 PUSH-FIT PNEUMATIC FITTINGS

KENNEDY® Push-Fit Pneumatic Fittings

QUALITY INDUSTRIAL TOOLING

Quick and simple tube insertion. Compact lightweight design with a well proven tube retaining system. Tapered threads have a re-usable thread seal and parallel threads have a rubber washer. Main body manufactured from nickel plated brass, acetal resin, PBT with a stainless steel retaining ring, nitrile tube seal and acetal resin tube release collar.

Pressure range: -0.9bar min to +10bar max. **Temp range:** -20°C min to +70°C max. **Tube suitability:** Nylon, polyurethane.

Thread Forms:

G = BSPP - British Standard Pipe, Parallel

R = BSPT - British Standard Pipe, Taper

M = ISO Metric [mm = Tube diameter]



Straight Connector



Model Number	Size (mm)	Order Code KEN-291	Price/1 TB
KC4	4	-2200K	163.00
KC6	6	-2210K	163.00
KC8	8	-2220K	163.00

Connector to Female Parallel



Model Number	Size (mm)	Order Code KEN-291	Price/1 TB
KC4-1FP	4 - G ¹ / ₈	-2260K	139.00
KC6-1FP	6 - G ¹ / ₈	-2270K	191.00
KC6-2FP	6 - G ¹ / ₄	-2280K	191.00
KC8-2FP	8 - G ¹ / ₄	-2290K	186.00
KC8-3FP	8 - G ³ / ₈	-2300K	258.00
KC10-2FP	10 - G ¹ / ₄	-2310K	380.00

Connector to Male Parallel



Model Number	Size (mm)	Order Code KEN-291	Price/1 TB
KC4-1MP	4 - G ¹ / ₈	-2350K	107.00
KC4-2MP	4 - G ¹ / ₄	-2360K	107.00
KC4-5MP	4 - M5	-2370K	107.00
KC6-1MP	6 - G ¹ / ₈	-2380K	107.00
KC6-2MP	6 - G ¹ / ₄	-2390K	112.00
KC6-5MP	6 - M5	-2400K	112.00
KC8-1MP	8 - G ¹ / ₈	-2410K	112.00
KC8-2MP	8 - G ¹ / ₄	-2420K	116.00
KC8-3MP	8 - G ³ / ₈	-2430K	139.00
KC10-2MP	10 - G ¹ / ₄	-2440K	139.00

Connector to Male Taper



Model Number	Size (mm)	Order Code KEN-291	Price/1 TB
KC4-1MT	4 - G ¹ / ₈	-2500K	163.00
KC4-2MT	4 - G ¹ / ₄	-2510K	163.00
KC6-3MT	6 - G ³ / ₈	-2540K	139.00
KC8-1MT	8 - G ¹ / ₈	-2550K	139.00
KC8-2MT	8 - G ¹ / ₄	-2560K	191.00
KC8-3MT	8 - G ³ / ₈	-2570K	191.00
KC8-4MT	8 - G ¹ / ₂	-2580K	218.00
KC10-1MT	10 - G ¹ / ₈	-2600K	163.00
KC10-4MT	10 - G ¹ / ₂	-2630K	198.00
KC12-3MT	12 - G ³ / ₈	-2650K	198.00
KC12-4MT	12 - G ¹ / ₂	-2660K	237.00

Elbow Connector



Model Number	Size (mm)	Order Code KEN-291	Price/1 TB
KEC4	4	-2700K	163.00
KEC6	6	-2710K	163.00
KEC8	8	-2720K	163.00
KEC10	10	-2730K	185.00
KEC12	12	-2740K	193.00

Elbow Connector to Stem

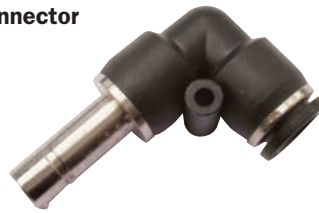

Model Number	Size (mm)	Order Code KEN-291	Price/1 TB
KEC8S-8	8 - 8	-2820K	153.00
KEC12S-12	12 - 12	-2840K	308.00

Elbow Connector to Male Parallel



Model Number	Size (mm)	Order Code KEN-291	Price/1 TB
KEC4-1MP	4 - G ¹ / ₈	-2900K	163.00
KEC4-2MP	4 - G ¹ / ₄	-2910K	163.00
KEC4-5MP	4 - M5	-2920K	163.00
KEC6-1MP	6 - G ¹ / ₈	-2930K	163.00
KEC6-2MP	6 - G ¹ / ₄	-2940K	163.00
KEC6-5MP	6 - M5	-2950K	163.00
KEC8-1MP	8 - G ¹ / ₈	-2960K	163.00
KEC8-2MP	8 - G ¹ / ₄	-2970K	163.00
KEC10-2MP	10 - G ¹ / ₄	-2980K	188.00

Elbow Connector to Male Taper



Model Number	Size (mm)	Order Code KEN-291	Price/1 TB
KEC4-1MT	4 - G ¹ / ₈	-3100K	163.00
KEC4-2MT	4 - G ¹ / ₄	-3110K	163.00
KEC6-1MT	6 - G ¹ / ₈	-3120K	163.00
KEC6-2MT	6 - G ¹ / ₄	-3130K	163.00
KEC6-3MT	6 - G ³ / ₈	-3140K	188.00
KEC8-1MT	8 - G ¹ / ₈	-3150K	163.00
KEC8-3MT	8 - G ³ / ₈	-3170K	188.00
KEC8-4MT	8 - G ¹ / ₂	-3180K	188.00
KEC10-1MT	10 - G ¹ / ₈	-3190K	243.00
KEC10-2MT	10 - G ¹ / ₄	-3200K	243.00
KEC10-3MT	10 - G ³ / ₈	-3210K	271.00
KEC10-4MT	10 - G ¹ / ₂	-3220K	271.00
KEC12-2MT	12 - G ¹ / ₄	-3230K	263.00
KEC12-3MT	12 - G ³ / ₈	-3240K	263.00

Elbow Reducer to Stem

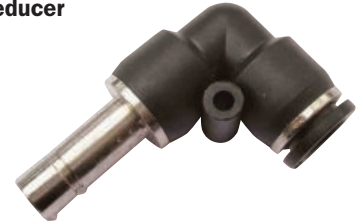

Model Number	Size (mm)	Order Code KEN-291	Price/1 TB
KER10S-8	10 - 8	-3640K	380.00

In-line Flow Restrictor



Model Number	Size (mm)	Order Code KEN-291	Price/1 TB
KFR-4	4	-3800K	685.00
KFR-6	6	-3810K	720.00
KRF-6	8	-3830K	720.00

Out-flow Restrictor to Male Taper



Model Number	Size (mm)	Order Code KEN-291	Price/1 TB
KFRE4-1MT	4 - G ¹ / ₈	-4000K	391.00
KFRE6-1MT	6 - G ¹ / ₈	-4020K	361.00
KFRE6-2MT	6 - G ¹ / ₄	-4030K	444.00
KFRE6-3MT	6 - G ³ / ₈	-4040K	720.00
KFRE8-1MT	8 - G ¹ / ₈	-4050K	364.00
KFRE8-2MT	8 - G ¹ / ₄	-4060K	596.00
KFRE8-3MT	8 - G ³ / ₈	-4070K	704.00
KFRE10-2MT	10 - G ¹ / ₄	-4080K	661.00

In-flow Restrictor



MT = Male Taper Thread

Model Number	Size (mm)	Order Code KEN-291	Price/1 TB
KFRT6-2MT	6 - G ¹ / ₄	-4530K	704.00
KFRT8-1MT	8 - G ¹ / ₈	-4540K	704.00
KFRT8-2MT	8 - G ¹ / ₄	-4550K	720.00
KFRT10-2MT	10 - G ¹ / ₄	-4570K	921.00

PUSH-FIT PNEUMATIC FITTINGS



Thread Forms:

G = BSPP - British Standard Pipe, **Parallel**
R = BSPT - British Standard Pipe, **Taper**
M = ISO Metric [mm = Tube diameter]

Push-Fit Pneumatic Fittings

Reducing Triple Branch Manifolds



Model Number	Size (mm)	Order Code KEN-291	Price/1 TB
KMT6-4	6 - 4	-5000K	353.00
KMT8-6	8 - 6	-5010K	353.00

In-line Reducer



Model Number	Size (mm)	Order Code KEN-291	Price/1 TB
KR10-8	10 - 8	-5420K	175.00

Stem Reducers



Model Number	Size (mm)	Order Code KEN-291	Price/1 TB
KR6S-4	6 - 4	-5500K	175.00
KR8S-6	8 - 6	-5520K	174.00
KR10S-6	10 - 6	-5530K	174.00
KR10S-8	10 - 8	-5540K	195.00
KR12S-8	12 - 8	-5560K	195.00
KR12S-10	12 - 10	-5570K	195.00

Equal Tees



Model Number	Size (mm)	Order Code KEN-291	Price/1 TB
KT4	4	-5700K	271.00
KT6	6	-5710K	243.00
KT8	8	-5720K	271.00
KT10	10	-5730K	266.00
KT12	12	-5740K	307.00

Branch Tee to Male Taper



Model Number	Size (mm)	Order Code KEN-291	Price/1 TB
KTB4-2MT	4 - G ¹ / ₄	-6510K	196.00
KTB6-1MT	6 - G ¹ / ₈	-6520K	196.00
KTB6-2MT	6 - G ¹ / ₄	-6530K	196.00
KTB6-3MT	6 - G ³ / ₈	-6540K	196.00
KTB8-1MT	8 - G ¹ / ₈	-6550K	308.00
KTB8-2MT	8 - G ¹ / ₄	-6560K	308.00
KTB8-3MT	8 - G ³ / ₈	-6570K	308.00
KTB8-4MT	8 - G ¹ / ₂	-6580K	308.00
KTB10-1MT	10 - G ¹ / ₈	-6590K	374.00
KTB10-2MT	10 - G ¹ / ₄	-6600K	374.00
KTB12-2MT	12 - G ¹ / ₄	-6630K	385.00
KTB12-4MT	12 - G ¹ / ₂	-6650K	385.00

'Y' Piece



Model Number	Size (mm)	Order Code KEN-291	Price/1 TB
KY4	4	-6800K	271.00
KY6	6	-6810K	299.00
KY8	8	-6820K	353.00
KY10	10	-6830K	380.00
KY12	12	-6840K	407.00

'Y' Reducers



Model Number	Size (mm)	Order Code KEN-291	Price/1 TB
KYR6-4	6 - 4	-7500K	231.00
KYR8-6	8 - 6	-7510K	263.00
KYR10-8	10 - 8	-7520K	274.00
KYR12-10	12 - 10	-7530K	288.00

Bulkhead Adaptors



Model Number	Size (mm)	Order Code KEN-291	Price/1 TB
KBH4	4 - 4	-2010K	271.00
KBH8	8 - 8	-2030K	299.00

Bulkhead to Female Parallel



Model Number	Size (mm)	Order Code KEN-291	Price/1 TB
KBH6-2FP	6 - G ¹ / ₄	-2110K	271.00
KBH8-1FP	8 - G ¹ / ₈	-2120K	380.00
KBH8-2FP	8 - G ¹ / ₄	-2130K	380.00
KBH10-2FP	10 - G ¹ / ₄	-2150K	462.00
KBH12-3FP	12 - G ³ / ₈	-2180K	596.00

Blanking Plugs



Model Number	Size (mm)	Order Code KEN-291	Price/1 TB
EPP4	4	-5200K	33.00
EPP8	8	-5220K	60.00
EPP10	10	-5230K	94.00

Conical Silencer

Sintered (with Hex) Type 1



Model Number	Size Male	Order Code KEN-259	Price/1 TB
S1-1	G ¹ / ₈	-6800K	170.00
S1-2	G ¹ / ₄	-6810K	170.00
S1-3	G ³ / ₈	-6820K	357.00
S1-4	G ¹ / ₂	-6830K	493.00
S1-6	G ³ / ₄	-6840K	821.00

Conical Silencer

Sintered (with Hex) Type 2



Model Number	Size Male	Order Code KEN-259	Price/1 TB
S2-1	G ¹ / ₈	-6870K	190.00
S2-2	G ¹ / ₄	-6880K	209.00
S2-3	G ³ / ₈	-6890K	493.00
S2-4	G ¹ / ₂	-6900K	572.00

Flow Regulators

Pressure range:
+1 to +10 bar.
Temperature range:
0 to +80°C.



Model Number	Size (mm)	Order Code KEN-259	Price/1 TB
Bi-Directional			
FR1-1	G ¹ / ₈	-6400K	670.00
FR1-2	G ¹ / ₄	-6410K	823.00
FR1-3	G ³ / ₈	-6420K	2189.00

Exhausting Slide Valve - Female to Female

Pressure range:
0 to +10bar.
Temperature range:
-18 to +70°C.



Model Number	Size (mm)	Order Code KEN-259	Price/1 TB
VAS1FF	G ¹ / ₈ - G ¹ / ₈	-7250K	773.00
VAS4FF	G ¹ / ₂ - G ¹ / ₂	-7280K	1391.00

Non-Return Valve - Female to Female

Pressure range:
+2 to +8bar.
Temperature range:
-25 to +90°C.

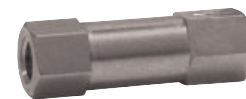

Model Number	Size (mm)	Order Code KEN-259	Price/1 TB
VNR1FF	G ¹ / ₈ - G ¹ / ₈	-7400K	603.00
VNR3FF	G ³ / ₈ - G ³ / ₈	-7420K	1313.00
VNR4FF	G ¹ / ₂ - G ¹ / ₂	-7430K	1313.00

Quick Exhaust Valve - Female to Female

Pressure range:
+0.3 to +10bar.
Temperature range:
-18 to +70°C.



Model Number	Size (mm)	Order Code KEN-259	Price/1 TB
VQE1FF	G ¹ / ₈ - G ¹ / ₈	-7500K	1040.00
VQE2FF	G ¹ / ₄ - G ¹ / ₄	-7510K	1133.00
VQE3FF	G ³ / ₈ - G ³ / ₈	-7520K	1133.00
VQE4FF	G ¹ / ₂ - G ¹ / ₂	-7530K	1236.00

Flat Head Silencer

Sintered (with Hex) Type 3



Model Number	Size Male	Order Code KEN-259	Price/1 TB
S3-1	G ¹ / ₈	-6940K	221.00
S3-2	G ¹ / ₄	-6950K	258.00
S3-3	G ³ / ₈	-6960K	441.00
S3-4	G ¹ / ₂	-6970K	466.00
S3-6	G ³ / ₄	-6980K	572.00

Dome Head Silencer

Sintered (with Hex) Type 4



Model Number	Size Male	Order Code KEN-259	Price/1 TB
S4-1	G ¹ / ₈	-7000K	215.00
S4-2	G ¹ / ₄	-7010K	239.00

ABRASIVES & POWER TOOLS

GROUP 295 WIRE WHEELS & BRUSHES



Industrial rotary wire wheels and brushes are available as a comprehensive range including circular brushes, shaft mounted arbor style and de-carbonising brushes for use with power tools, machine tools and flexible drives.

EXTENDED RANGE

Circular Brushes - Plain Bore

Suitable for removal of rust, paint and dirt from heavily covered parts. Order side plates separately.

(See below right).
30 SWG



Diameter x Width x Bore (mm)	Max. RPM	Order Code KEN-295	Price/1 TB
Steel Wire Brushes			
80 x 15 x 20	10,000	-0030K	186.00
80 x 22 x 20	10,000	-0060K	250.00
100 x 20 x 30	6,000	-0140K	181.00
100 x 28 x 30	6,000	-0170K	258.00
125 x 22 x 30	6,000	-0360K	464.00
125 x 30 x 30	6,000	-0390K	567.00
150 x 21 x 51	6,000	-0450K	438.00
150 x 29 x 51	6,000	-0480K	464.00
200 x 21 x 80	4,500	-0650K	696.00
200 x 29 x 80	4,500	-0680K	1082.00
Brass Wire Brushes			
80 x 22 x 20	4,500	-0920K	464.00
100 x 20 x 30	6,000	-0940K	412.00
150 x 21 x 51	6,000	-0960K	670.00
200 x 29 x 80	4,500	-0980K	979.00

Circular Brushes Twist Knot - Plain Bore

A more aggressive circular brush. The twist knot construction allows a higher surface speed.

35 SWG



Diameter x Width x Bore (mm)	Max. RPM	Order Code KEN-295	Price/1 TB
75 x 11 x 13	20,000	-1010K	514.00
100 x 11 x 22	12,500	-1110K	531.00
115 x 11 x 22	11,000	-1210K	567.00
115 x 11 x M14 Threaded	11,000	-1220K	618.00



Circular Brushes - Shaft Mounted

Suitable for use in power drills. Most suitable for hard to reach areas and grooves.

6mm shanks.
30 SWG



EXTENDED RANGE

Diameter x Width (mm)	Max. RPM	Order Code KEN-295	Price/1 TB
Steel Wire Brushes			
30 x 5	20,000	-2000K	165.00
30 x 10	20,000	-2010K	165.00
30 x 12	20,000	-2030K	126.00
40 x 13.5	20,000	-2140K	126.00
40 x 18	20,000	-2160K	126.00
50 x 10	15,000	-2320K	165.00
50 x 15	15,000	-2350K	170.00
50 x 20	15,000	-2370K	324.00
60 x 10	15,000	-2420K	149.00
60 x 15	15,000	-2450K	274.00
60 x 20	15,000	-2470K	518.00
70 x 10	15,000	-2620K	159.00
70 x 15	15,000	-2650K	225.00
70 x 20	15,000	-2670K	412.00
80 x 10	12,000	-2720K	159.00
80 x 15	12,000	-2750K	301.00
80 x 20	12,000	-2770K	324.00
Brass Wire Brushes			
30 x 12	20,000	-2800K	206.00
50 x 10	15,000	-2820K	155.00
70 x 15	15,000	-2840K	308.00
80 x 20	12,000	-2860K	361.00

Additional Side Plates for Circular Brushes



Size (mm)	Order Code KEN-295	Price/1 TB	Size (mm)	Order Code KEN-295	Price/1 TB
20x13	-9130K	27.00	51x20	-9390K	27.00
20x16	-9160K	27.00	80x13	-9430K	56.00
30x13	-9230K	27.00	80x16	-9460K	56.00
30x16	-9260K	27.00	80x20	-9490K	56.00
30x20	-9290K	27.00	100x13	-9530K	116.00
51x13	-9330K	27.00	100x16	-9560K	116.00
51x16	-9360K	27.00	100x20	-9590K	116.00

Cup Brushes - Shaft Mounted

For all round use, ideal for work on larger surfaces removing burrs, rust and paint. 6mm shanks.

30 SWG



EXTENDED RANGE

Diameter x Width (mm)	Max. RPM	Order Code KEN-295	Price/1 TB
Steel Wire Brushes			
40 x 10	11,000	-3120K	137.00
45 x 10	11,000	-3220K	258.00
50 x 10	11,000	-3320K	235.00
50 x 50	11,000	-3380K	274.00
60 x 15	11,000	-3450K	301.00
60 x 60	11,000	-3490K	301.00
70 x 15	4,500	-3650K	335.00
70 x 70	4,500	-3700K	366.00
Brass Wire Brushes			
40 x 10	11,000	-3820K	205.00
50 x 10	11,000	-3840K	232.00
70 x 70	11,000	-3860K	361.00

Cup Brushes

Multi-purpose brush for removal of rust, paint and burrs.

Ideally suited for use on bench machines and angle grinders.
30 SWG



Dia. (mm)	Arbor	Max. RPM	Order Code KEN-295	Price/1 TB
75	22mm Plain	12,500	-4310K	324.00
75	M14 Thrd	12,500	-4330K	520.00
75	5/8" BSW	12,500	-4340K	514.00
100	22mm Plain	10,000	-4420K	567.00
100	M14 Thrd	10,000	-4430K	357.00
100	5/8" BSW	10,000	-4440K	482.00
125	M14 Thrd	6,000	-4530K	487.00
125	5/8" BSW	-	-4540K	1250.00
150	M14 Thrd	6,000	-4630K	520.00

Cup Brushes Twisted Knot - Threaded Bore

For fast and heavy duty cleaning. Support ring prevents excessive spreading. For removal of rust, paint and scale on large surfaces.

50 SWG



Dia. (mm)	Arbor	Max. RPM	Order Code KEN-295	Price/1 TB
Steel Wire Brushes				
65	M14 Thread	12,500	-5230K	466.00
75	M14 Thread	9,000	-5330K	575.00
100	22mm Plain	8,500	-5420K	876.00
100	M14 Thread	8,500	-5430K	827.00
100	5/8" BSW	8,500	-5440K	876.00
120	M14 Thread	6,000	-5470K	1258.00
120	5/8" BSW	6,000	-5480K	1258.00
Brass Wire Brushes				
75	M14 Thread	12,500	-4160K	464.00
100	M14 Thread	10,000	-4180K	567.00
100	22 Plain	10,000	-4400K	567.00

WIRE WHEELS & BRUSHES

KENNEDY Industrial
QUALITY INDUSTRIAL TOOLING® **Wire Wheel Sets**

All supplied in clear bag with header.

5 Piece Set Contents (1 off each):

Shaft mounted circular brushes
30 x 12, 50 x 10 and 50 x 20.
Flat end decarbonising 12 x 20.
Pointed end decarbonising 12 x 20.

**5
PIECES**



Number of Pieces	Weight each	Order Code KEN-295	Price/1 TB
5	250g	-9800K	903.00

6 Piece Set Contents (1 off each):

Flat end decarbonising brushes 12 x 20, 17 x 22 and 24 x 25.
Pointed end decarbonising brushes 12 x 20, 17 x 22 and 24 x 25.



**6
PIECES**

Number of Pieces	Weight each	Order Code KEN-295	Price/1 TB
6	250g	-9900K	860.00

Pointed End Decarbonising Brushes

For use in high speed air and electrical tools. Ideal for hard to reach areas. For the removal of paint, carbon and for deburring. 6mm shanks. 30 SWG



EXTENDED RANGE

Diameter x Width (mm)	Max RPM	Order Code KEN-295	Price/1 TB
Steel Wire Brushes			
12 x 20	20,000	-7320K	112.00
17 x 22	20,000	-7440K	170.00
24 x 25	20,000	-7600K	192.00
30 x 25	20,000	-7800K	280.00
Brass Wire Brushes			
12	20,000	-7920K	155.00
24	20,000	-7940K	205.00

8 Piece Set Contents (1 off each):

Shaft mounted circular brushes 30 x 12, 50 x 20 and 80 x 20. Flat end decarbonising brushes 12 x 20 and 24 x 25. Pointed end decarbonising brushes 12 x 20 and 24 x 25. Shaft mounted cup brush 50 x 50.



**8
PIECES**



Number of Pieces	Weight each	Order Code KEN-295	Price/1 TB
8	630g	-9850K	1307.00

Flat End Decarbonising Brushes

For hard to reach areas such as drilled holes, recesses and corners. For removal of burrs, rust and paint. 30 SWG



EXTENDED RANGE

Diameter x Width (mm)	Max RPM	Order Code KEN-295	Price/1 TB
Steel Wire Brushes			
12 x 20	20,000	-6320K	105.00
17 x 22	20,000	-6440K	110.00
24 x 25	20,000	-6600K	165.00
30 x 25	20,000	-6800K	247.00
Brass Wire Brushes			
12	20,000	-7020K	155.00
24	20,000	-7040K	205.00

ABRASIVES & POWER TOOLS

PRODUCTS ARE ONLY AVAILABLE VIA YOUR DISTRIBUTOR

GROUP 300 DIAL GAUGES



Page **246 - 247**

GROUP 302 AXIS GAUGING



Page **248**

GROUP 303 HARDNESS TESTERS



Page **248**

GROUP 306 GRANITE BLOCKS & PLATES



Page **249**

GROUP 312 THERMOMETERS



Page **250**

GROUP 312 ENVIRONMENT METERS



Page **250**

GROUP 314 MECHANICAL COUNTERS



Page **251**

GROUP 314 STOPWATCHES



Page **251**

GROUP 315 TACHOMETERS



Page **251**

GROUP 316 EYE LOUPES & MAGNIFIERS



Page **252 - 253**

GROUP 318 BINOCULARS



Page **254 - 255**

GROUP 318 MICROSCOPES



Page **256**

GROUP 330 PROTRACTORS & COMBINATION SETS



Page **257**

GROUP 330 HEIGHT GAUGES



Page **257**

GROUP 330 THICKNESS GAUGES



Page **257**

GROUP 330 DIAL CALIPERS



Page **258**

GROUP 330 VERNIER CALIPERS



Page **259**

GROUP 331 DIGITAL CALIPERS



Page **260 - 261**

GROUP 331 DIGITAL DEPTH GAUGES



Page **261**

GROUP 331 DIGITAL INDICATORS



Page **262**

GROUP 331 DIGITAL MICROMETERS



Page **262**

GROUP 333 MAGNETIC BASES & FITMENTS



Page **263 - 265**

GROUP 335 BORE GAUGES



Page **266**

GROUP 335 MICROMETERS



Page **267 - 270**

GROUP 336 REFRACTOMETERS



Page **271**

GROUP 338 GAUGE BLOCKS



Page **271**

GROUP 340 ENGINEER'S LEVELS & SQUARES



Page **270**

GROUP 360 SCREW PLUG GAUGES

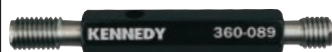

Page **270**

GROUP 370 STEEL BLOCKS & PLATES



Page **272**

GROUP 372 STEEL PARALLELS



Page **273**



PRECISION EQUIPMENT

**Product Groups
300 - 385**

Product Grading



Production

High performance industrial tooling designed for continuous use applications on machine tools where repeatability and long tool life are of critical importance.



Professional

Industrial tooling that has enhanced features and benefits demanded by craftsmen and professional users.



Industrial

Designed for regular use in industrial applications. Manufactured to stringent quality levels and international standards.



Workshop

Standard quality tooling for use by tradesmen and generally industrial use.



Maintenance

Products designed for general maintenance of machines, workshops, garages and some household applications.



Home Improver

DIY quality tooling. Designed for home use and light industrial applications.

Contents

Description	Group	Page
Axis Gauging	302	248
Binoculars	318	254 - 255
Bore Gauges	335	266
Calipers - Dial	330	258
- Vernier	330	259
Combination Sets	330	257
Counters	314	251
Dial Gauges	300	246 - 247
Digital Calipers	331	260 - 261
Depth Gauges	331	266
Indicators	331	262
Micrometers	331	262
Thickness Gauges	330	257
Engineer's Levels & Squares	341	270
Environment Meters	312	250
Eye Loupes & Magnifiers	316	252 - 253
Granite Products	306	249
Hardness Testers	303	248
Height Gauges	330	257
Magnetic Bases & Comparator Stands	333	262 - 265
Micrometers - Bore	335	266
- Digital	331	262
- External	335	265
Microscopes	318	256
Refractometers	336	271
Screw Gauges	360	270
Steel Gauge Blocks	338	271
Parallels	372	273
Vee Blocks, Squares & Surface Plates	370	272
Stopwatches	314	251
Tachometers	315	251
Thermometers	312	250
Thickness Gauges - Dial	330	257

GROUP 300 DIAL GAUGES

OXFORD PRECISION Easy Read Dial Gauges Plunger Type

58mm (2¼") Diameter Dial
Matt finish chromed housing and black oxidised limit hands. Fitted with ¼" inside diameter stem. Manufactured to **BS 907**.



58mm Diameter

Spares to suit Oxford Plunger Type Gauges

Description	Order Code KEN-301	Price/1 TB
Anvil - mm	-9400K	205.00

Graduation	Travel	Reading	Weight each	Order Code OXD-300	Price/1 TB
0.001"	0.5"	0-50-0	440g	-8100K	882.00
0.01mm	5mm	0-50-0	350g	-7850K	1255.00
0.01mm	10mm	0-100	440g	-8500K	1495.00
0.01mm	25mm	0-100	440g	-8520K	2215.00

Easy Read Dial Gauges Plunger Type

58mm (2¼") Diameter Dial 6 Jewel
Matt finish chromed housing and black oxidised limit hands. Shockproof mechanism. Fitted with ¼" inside diameter stem. Manufactured to **BS 907**.

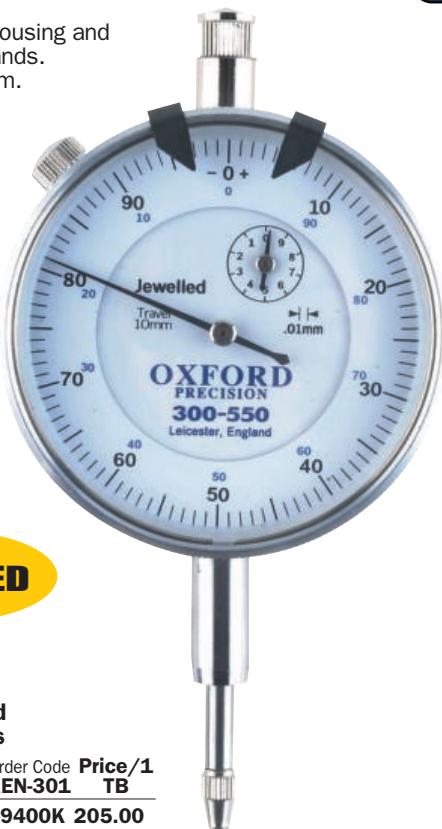

58mm Diameter

JEWELLED

Spares to suit Oxford Plunger Type Gauges

Description	Order Code KEN-301	Price/1 TB
Anvil - mm	-9400K	205.00

Graduation	Travel	Reading	Weight each	Order Code OXD-300	Price/1 TB
0.01mm	10mm	0-100	440g	-5500K	1775.00
0.01mm	25mm	0-100	440g	-5520K	2982.00

KENNEDY QUALITY INDUSTRIAL TOOLING Easy Read Dial Gauges Plunger Type

58mm (2¼") Diameter Dial
Easy Read Dial Gauges and DTI's are designed for countless applications and available in two basic styles. With shockproof mechanisms and clear, 'Easy Read' dial for zero setting. All models are operational in both directions. Supplied in fitted cases with accessories storage space.



58mm Diameter

Matt finish chromed housing and black oxidised limit hands. Fitted with ¼" inside diameter centre back lug and 5/16" diameter stem. Manufactured to **BS 907**.

Spares to suit Kennedy Plunger Type Gauges

Description	Order Code KEN-301	Price/1 TB
Anvil - mm	-9400K	205.00

Graduation	Travel	Reading	Weight each	Order Code KEN-300	Price/1 TB
0.001"	0.5"	0-50-0	440g	-7100K	1018.00
0.001"	0.5"	0-100	440g	-7110K	1375.00
0.0005"	0.5"	0-25-0	440g	-7120K	1018.00
0.001"	1.0"	0-100	440g	-7160K	948.00
0.0005"	1.0"	0-50	440g	-7170K	1191.00
0.01mm	10mm	0-100	440g	-7500K	1111.00
0.01mm	25mm	0-100	440g	-7520K	2435.00

Smile Dial Gauges Plunger Type

58mm (2¼") Diameter Dial
Matt finish chromed housing and black oxidised limit hands. Jewelled. Fitted with ¼" inside diameter centre back lug and 5/16" diameter stem. Manufactured to **BS 907**.

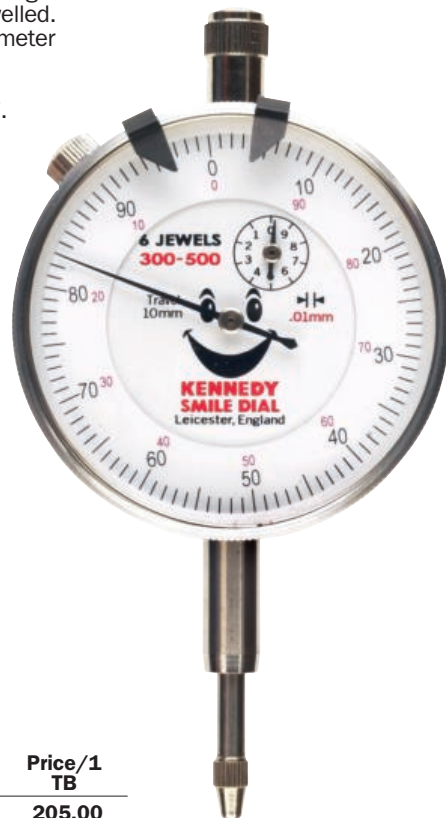

JEWELLED

58mm Diameter

Spares to suit Kennedy Plunger Type Gauges

Description	Order Code KEN-301	Price/1 TB
Anvil - mm	-9400K	205.00

Graduation	Travel	Reading	Weight each	Order Code KEN-300	Price/1 TB
0.01mm	10mm	0-100	440g	-5000K	1495.00

PRECISION EQUIPMENT

KENNEDY *Easy Read Anti-Magnetic Dial Test Indicators*

32mm (1 1/4") Diameter Dial Lever Type

Supplied with dovetail fitting and 6 and 8mm spigot. Matt finish chromed housing. Jewelled.

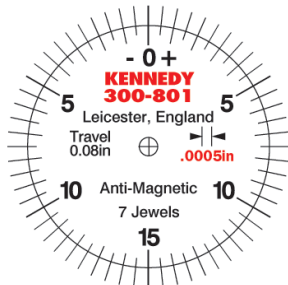

JEWELLED

Spares to suit Kennedy Dial Test Indicators

Description	Order Code	Price/1 TB			
Replacement Stylus	-9630K	158.00			
Universal Holder	-9840K	646.00			
Description	Order Code	Price/1 TB			
1/4" Spigot - 6mm Stem	-0340K	140.00			
1/4" Spigot - 8mm Stem	-0350K	140.00			
Graduation	Travel	Reading	Weight each	Order Code	Price/1 TB
0.0005"	0.03"	0-15-0	170g	-8010K	2544.00
0.01mm	0.8mm	0-40-0	170g	-8020K	2550.00

Dovetail Mounting Accessories

Spigot
1/4" standard type.

Stem Diameter	Weight each	Order Code	Price/1 TB
4mm	20g	-0330K	140.00
6mm	20g	-0340K	140.00
8mm	20g	-0350K	140.00

Dial Gauge Accessories

Replacement Anvils

For all Kennedy plunger type dial gauges. Steel.

Type	Weight each	Order Code	Price/1 TB
Metric	.082g	-9400K	205.00

Universal Spigot

For lever type (not easy read).

Type	Weight each	Order Code	Price/1 TB
1/4" ID	20g	-9840K	646.00

Replacement Stylus

Carbon Steel. Replacement stylus for all Kennedy lever type dial test indicators (except dual reading stylus for KEN-300-4000K).

Suitable for use with	Order Code	Price/1 TB
New Style Easy Read DTI's	-9630K	158.00

OXFORD *Easy Read Dial Test Indicators*

32mm Diameter Dial Lever Type

Supplied with dovetail fitting and 6 and 8mm spigot. Matt finish chromed housing.



Spares to suit Oxford Dial Test Indicators

Description	Order Code	Price/1 TB			
Replacement Stylus	-9630K	158.00			
Universal Holder	-9840K	646.00			
Description	Order Code	Price/1 TB			
1/4" Spigot - 6mm Stem	-0340K	140.00			
1/4" Spigot - 8mm Stem	-0350K	140.00			
Graduation	Travel	Reading	Weight each	Order Code	Price/1 TB
0.01mm	0.8mm	0-40-0	170g	-9020K	2327.00

1 1/4" Dial Diameter



Spares to suit Oxford Dial Test Indicators

Description	Order Code	Price/1 TB			
Replacement Stylus	-9630K	158.00			
Universal Holder	-9840K	646.00			
Description	Order Code	Price/1 TB			
1/4" Spigot - 6mm Stem	-0340K	140.00			
1/4" Spigot - 8mm Stem	-0350K	140.00			
Graduation	Travel	Reading	Weight each	Order Code	Price/1 TB
0.0005"	0.03"	0-15-0	170g	-9010K	2338.00

PRECISION EQUIPMENT

The New Generation of NC axis gauging equipment, for quick, accurate setting of all three axes (X, Y, Z) by analogue differential indicator. Suitable for all machine tools with CNC, NC or DRO and also for EDM/spark erosion tools - the stylus is electrically insulated from the spindle. Universal - one tool measures length, height, diameter and centre. The synchronous single needle allows greater needle displacement before reaching '12 o'clock'. A positive reading is given regardless of direction of axis movement. No calculations and no 'trial and error' involved. Increases production and efficiency, reduces job time and operator requirement. The stylus is designed to break on a 'nominal fracture' before the workpiece or tester can be damaged. Three plug in styli types can be changed in seconds without the use of special tools. Pre-adjusted to a concentricity of 0.01mm maximum.

Indicator diameter: 50mm.

Clamping shank diameter: 16mm.

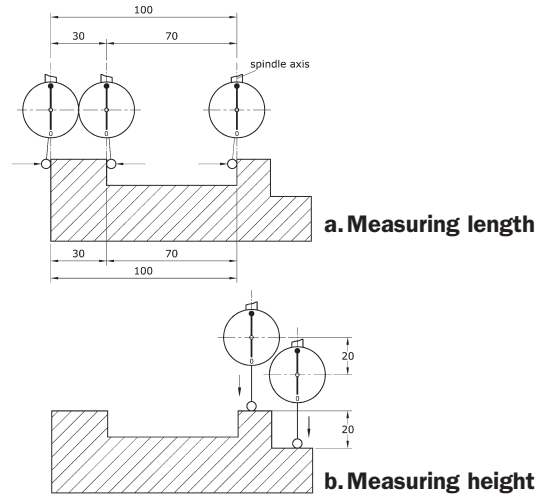

c. Establishing true centre and diameter of bores.

Insert stylus roughly in centre of bore, measure distance A and divide by 2 (P). Measure distance B in Y direction, across point P and divide by 2.

Result: true centre point (M). Repeat measuring of distance A.

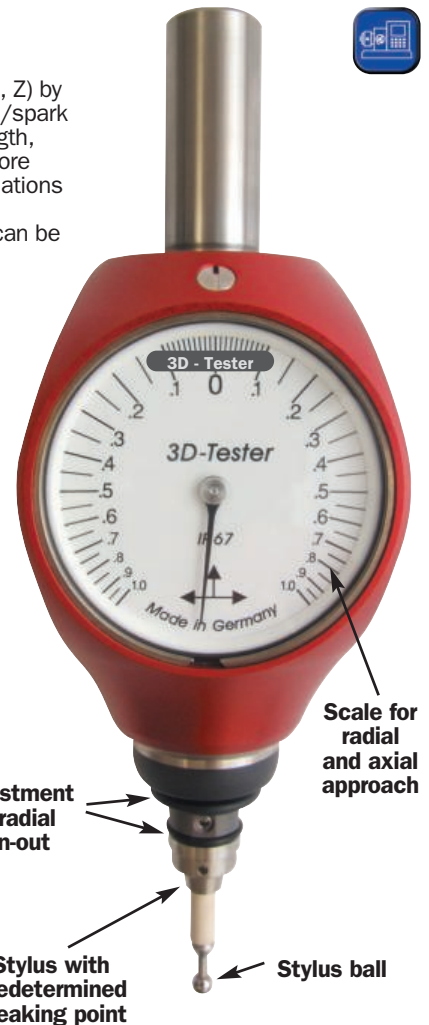
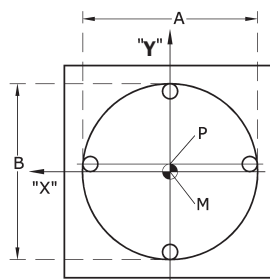

3D Axis Gauge

Indicator Dia.	Effective Length	Shank Dia.	Weight each	Order Code	Price/1 TB
50mm	125mm	16mm	89g	KEN-302 -2010K	19055.00

OXFORD PRECISION Hardness Testers

Rockwell Hardness Tester Model 150R

For testing the hardness of hard alloys, quenched and unquenched steels, using steel ball or diamond penetrators to measure Rockwell A, B & C units of measurement. Supplied with test block, flat large, small and V notch anvils, steel ball bearing indenter and diamond indenter. Manufactured in accordance with **ISO 6508-2:1999 & ASTM E18**.

Measuring ranges:

- 20-88HRA (Test force: 588.4N/60kgf),
- 20-100HRB (Test force: 980.7N/100kgf),
- 20-70HRC (Test force: 1471N/150kgf).

Max height of test piece:

80mm with screw protective jacket, 170mm without.

Depth of throat: 135mm.

Dimensions:

466 x 238 x 630mm.



Model Number	Weight each	Order Code	Price/1 TB
150R	65kg	-1000K	91303.00

Anvils, Indentors & Test Blocks

To suit Oxford hardness tester.



Description	Size	Order Code	Price/1 TB
Large Flat Anvil	150mm	-9100K	3415.00
Small Flat Anvil	58mm	-9110K	2578.00
V-Notch Anvil	-	-9120K	2632.00
Diamond Indentor	ø1.588mm	-9150K	14741.00
Steel Ball Bearing Indentor	ø1.588mm	-9160K	2895.00
	88 HRA	-9200K	1393.00
	85 HRB	-9210K	1393.00
Rockwell Std. Test Blocks	60 HRC	-9220K	1393.00
60 x 40 x 10mm	35 HRC	-9230K	1393.00
	20 HRC	-9240K	1393.00



Oxford Precision Granite Products

Precision granite products are manufactured to the highest quality standards to provide an accurate surface from which final measurements can be taken. More dimensionally stable than steel or cast iron, with a low thermal expansion co-efficient. Does not burr, is corrosion free and easy to maintain.

Granite Straight Edges

Used for checking surfaces for straightness, drawing and scribing straight lines. Made to **BS5204 : Grade A**.



L x W x H	Weight each	Order Code OXD-306	Price/1 TB
630 x 100 x 50mm	7kg	-6020K	8755.00
1000 x 160 x 50mm	10kg	-6040K	22145.00

Granite Parallels

Used for setting up work on machine tables and surface plates. Made to **BS906 : Part 1 : Grade B** for flatness and parallelism of working faces. Supplied in pairs.



L x W x H	Weight each	Order Code OXD-306	Price/Pr TB
160 x 25 x 16mm	0.55kg	-3020K	7725.00
250 x 40 x 25mm	1.83kg	-3040K	12875.00
400 x 63 x 40mm	6.97kg	-3060K	13905.00

Granite Vee Blocks

90°. Used for handling and inspecting round work. Also used for layout work. Made to **BS3731 : Grade 2**. Supplied in pairs.



L x W x H	Weight each	Order Code OXD-306	Price/Pr TB
62 x 62 x 62mm	2.0kg	-7020K	21018.00

Granite Surface Plates

Accurate bases which are used for mounting sensitive measuring, mechanical and electronic equipment. Made to **BS817**. Supplied with **UKAS** calibration certificate.



Stand

Grade 1 - Inspection Grade

L x W x H	Weight each	Order Code OXD-306	Price/1 TB
400 x 250 x 70mm	27kg	-4020K	9785.00
630 x 400 x 100mm	90kg	-4040K	22594.00
800 x 500 x 100mm	140kg	-4060K	29870.00

Stand - To suit Granite Surface Plate (OXD-306-4060K) Only

L x W x H	Weight each	Order Code OXD-306	Price/1 TB
800 x 500 x 650mm	20kg	-4100K	13905.00

Granite Squares

90°. For measuring and inspecting squareness, parallelism and alignment. Made to **BS939 : 1977 Grade A** for flatness, straightness and squareness of working faces.

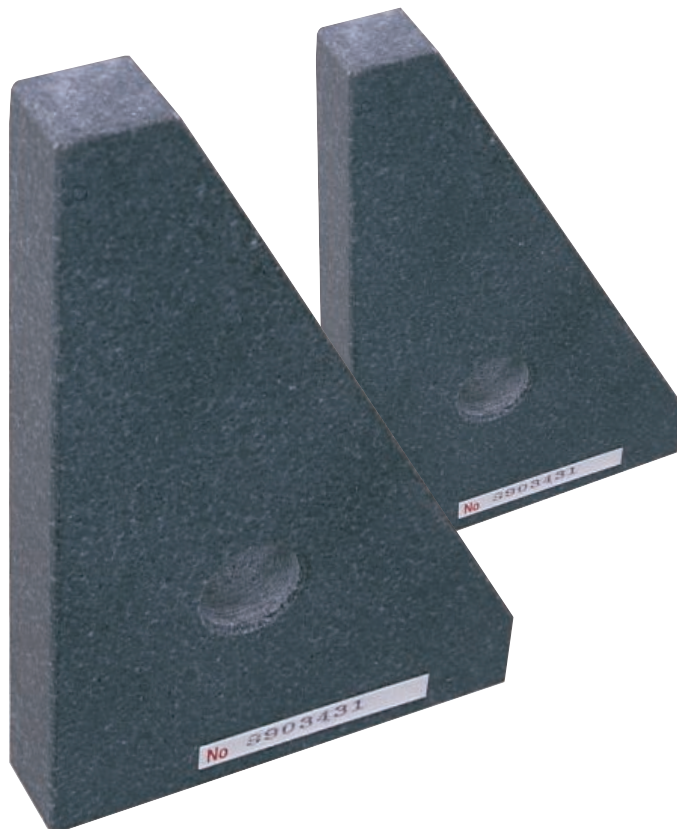

L x W x H	Weight each	Order Code OXD-306	Price/1 TB
250 x 160mm	2.26kg	-5060K	7725.00

PRECISION EQUIPMENT

EDISON Infrared Laser Thermometer

A high resolution infrared laser thermometer suitable for a wide range of industrial applications, HVAC and automotive diagnostics. Laser targeting enables accurate readings by guiding the user to the optimum measuring distance. Suited for work in confined spaces. Simply aim, pull the trigger and read the current surface temperature. Laser can be activated via the laser button for more accurate targeting. Temperature is displayed on back-lit LCD display.

Measurement range: -20°C to 537°C.

Accuracy: -20°C to 50°C +/- 2.5°C, 51°C to 537°C +/- (Reading x 1% 1°C).

Distance to spot ratio: 12:1.

Emissivity: 0.95.

Celsius/Fahrenheit selection. Back light display.

Power source: 9V battery. Average/maximum/minimum/maximum-minimum mode selection.

Complies with EN61326:1997/A1:1998/A2:2001/A3:2003.

Dimensions (L x W x H): 162 x 56 x 190mm.

Nett weight: 270g.

Range: -20°C to +537°C

BEST SELLER



12:1 Distance to Spot
-20°C to **+537°C**

Model Number	Order Code	Price/1 TB
IRT537	EDI-312-4000K	4378.00

Mini Laser Thermometer



Pocket sized infrared thermometer employing single dot infrared laser technology to instantly display surface temperatures. °C/°F selectable with a measurement range of between -20°C to 270°C (-4° to 518°F). Features ambient temperature (TAMB) measurement, back light, hold function and low battery indication. Supplied with wrist lanyard and 2x AAA batteries.

NEW

6:1 Distance to Spot

-20°C to **+270°C**

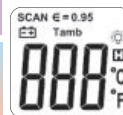

Model Number	Order Code	Price/1 TB
EPT960	EDI-312-3960K	1700.00

Infrared & Probe Thermometer

Features two measurement modes - probe for internal temperature and infrared single dot laser for surface temperature.

°C/°F selectable, it has a measurement range of between -20°C to 270°C (-4° to 518°F).

With back light, auto power 'OFF' and low power indicator, and a carry case. Requires 3 x AAA batteries (included).

NEW



6:1 Distance to Spot
-20°C to **+270°C**

Model Number	Order Code	Price/1 TB
EPT980	EDI-312-3980K	3193.00

Airflow, Velocity & Thermometer

TVA150

It is used to measure air speed at ventilation outlets and test temperatures in offices, storerooms, greenhouses and places where climate conditions can be analysed.

Conforms with **EN61326-6: 2006** and **EN61326-2-2: 2006**.

Meter capabilities:

- Airflow: m/s, km/h, fpm, mph, kts.
- Beaufort scale.
- Temperature in both °C and °F.
- 4 digit display with optional back light.
- Data hold function.
- Auto power 'OFF' and low power indicator.
- 3x AAA battery included.

Testing ranges:

0.4 - 20m/s, 80 - 4000fpm, -10 - 50°C (14 - 122°F).



Model Number	Order Code	Price/1 TB
TVA150	EDI-312-4020K	4929.00

Relative Humidity & Temperature Tester

THM150

Ideal for temperature, humidity and dew point testing in offices, storerooms, greenhouses and places where a controlled environment is essential. Conforms with **EN61326-6: 2006** and **EN61326-2-2: 2006**.

Meter capabilities:

- Temperature: -10 - 50°C (14 to 122°F).
- Testing humidity: 0 - 100%RH.
- 4 digit clear LCD display with optional back light.
- Data hold function.
- Auto power 'OFF' and low power indicator.
- 3x AAA battery included



Model Number	Order Code	Price/1 TB
THM150	EDI-312-4040K	3735.00

5-in-1 Multimeter & Environmental Tester



MET060

Relative measurement function. Diode testing facility. Clear display with LED back light and data hold function. Auto power OFF and low power indicator. Digital display count up to 3999. Supplied with test probes, clamp-on test leads, temperature sensor probe, 9V battery, and Instructions manual. Conforms with **IEC 1010, CAT II 1000V** and **CAT III 600V**.

Temperature: from -20 to 1000°C.

Humidity: 30 - 90%.

Sound: 35 - 100db.

Illumination: 4000 - 40000 Lux.

AC/DC: 600V.

AC/DC: 10A.

Resistance: 40MW.

Capacitance: 200mF.

Frequency: 1Hz to 200KHz.

Dimensions (W x D x H): 165 x 65 x 230mm.



Model Number	Order Code	Price/1 TB
MET060	EDI-516-3460K	5722.00



Multi Function Digital Stopwatch - Standard

Water and shock resistant design. Supplied with nylon neck cord.

Specification:
1/100 second precision with split times. Calendar and time display 12hr or 24hr format. Daily alarm. Hourly chime. Supplied complete with 1.5V battery.



Order Code RTL-314	Price/1 TB
-3020K	953.00

Multi Function Digital Stopwatch - Professional

Water and shock resistant design, slim line contour case fits comfortably in the hand. Supplied with nylon neck cord.

Specification:
1/100 second precision with split times. Calendar and time display 12hr or 24hr format. Fastest, slowest and average lap calculation. Daily alarm. Hourly chime. Supplied complete with 1.5V battery.



Order Code RTL-314	Price/1 TB
-3040K	2112.00



Electronic Tally Counter - Up

Electronic tally counter counts up to 9999. Four-digit LCD with large push-buttons. High-impact construction with comfortable rubber keys. Optional audible counting indicator. Battery included.

Size (W x D x H): 30 x 15 x 60mm.



Order Code OXD-314	Price/1 TB
-5820K	617.00



Mechanical Stroke Counter

Five digit mid-range mechanical stroke counter. Tough plastic case. Excellent value.

Overall length: 80mm.
Height: 30mm.

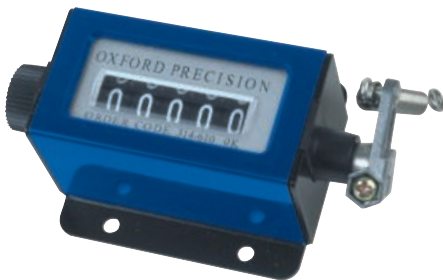

Spindle Rotation	Weight each	Order Code	Price/1 TB
Right Hand	91g	OXD-314	-6100K 428.00

Chrome Tally Counters

Four digit (0-9999) metal body mechanical counters with push button actuator and reset button. Sturdy chrome plated steel construction.

Hand Tally comfortably fits in the palm of your hand, audible click, finger ring and recommended for applications where operator must be mobile.



Desk Tally features a special mounting base designed for desk, bench or clipboard mounting. Recommended for fixed applications.

Description	Weight each	Order Code	Price/1 TB
Hand Tally	60g	-5500K	325.00
Desk Tally	70g	-5520K	325.00

Electronic Tally Counter - Up/Down

Electronic tally counter counts up to 9999. Four-digit LCD with large push-buttons. Reverse function to count down as well as up. High-impact construction with comfortable rubber keys. Optional audible counting indicator. Battery included.

Size (W x D x H): 30 x 15 x 60mm.



Order Code OXD-314	Price/1 TB
-5830K	720.00



Electronic Tachometer

Precise red LED light source (laser beam) together with a reflective strip, non-contact measurements can be made safely up to 40cm (15 3/4") from the target.

For measuring in rpm and rps.

Testing range:
100 to 30000rpm/1.7 to 500rps.
6 digit clear LCD display with optional back light.
Data hold function.
Auto power 'OFF' and low power indicator.
Battery operated: DC1.5V 3x AAA (included).
Conforms with **EN61326-6: 2006** and **EN61326-2-2: 2006**.

Pack includes:
Digital tachometer.
Wrist strap.
2x 30cm reflective strips.
Hard carry case.
DC1.5V 3x AAA batteries (installed).
Instruction manual.



Actual size of LCD



Test for regular rotary speed



Laser beam accuracy



Complete with protective head cover

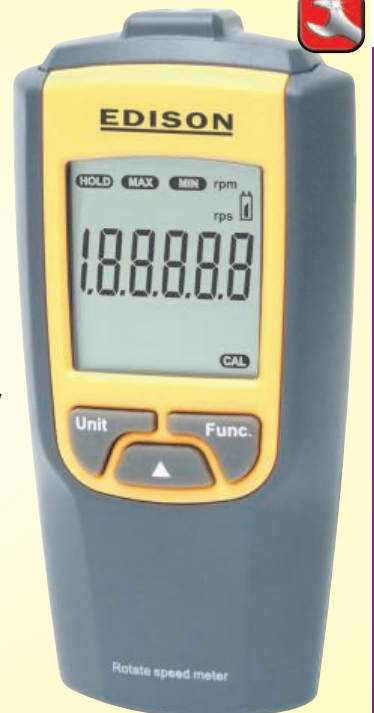

Testing Range	Order Code	Price/1 TB
100 to 30000rpm	EDI-315	-4200K 4069.00

GROUP 316 EYE LOUPES & MAGNIFIERS

OXFORD PRECISION Folding Pocket Magnifiers

15mm Diameter

Although deriving its name from the textile industry it is also suitable for inspecting paper, photographs, printed documents etc. 15mm diameter glass lens. 7x magnification. 1" working distance. 1/2" square field. Inch graduation. 1/8" divisions. Self-standing to free your hands. Folds flat when not in use. Black powder coated body. The original 'Linen tester'.



Diameter	Order Code OXD-316	Price/1 TB
15mm	-1600K	692.00

Folding Pocket Magnifier

30mm Diameter

Although deriving its name from the textile industry it is also suitable for inspecting paper, photographs, printed documents etc. 30mm diameter glass lens. 6x magnification. 38mm (1 1/2") working distance. 25mm (1") square field. Metric and inch graduations. 1mm and 1/8" divisions. Self-standing to free your hands. Folds flat when not in use. Black powder coated body. Complete with plastic wallet. The original 'Linen tester'.



Diameter	Order Code OXD-316	Price/1 TB
30mm	-1620K	692.00

LED Light Magnifier

30mm Diameter

10x magnification. 5mm diameter LED light. 30mm diameter integral 2x optical glass lens. Powered by 3x AAA batteries (not supplied). LED lasts around 40,000 hours under normal use. Battery life = 40/50 hours under continuous use. Compared to a conventional bulb the LED diode lives up to 1000 times longer with 90% less power consumption. Complete with plastic case with belt loop.



Diameter	Order Code OXD-316	Price/1 TB
30mm	-2010K	1563.00

Magnifying Loupes

Suitable for precision engineers, instrument makers, watch repairers, jewellers etc.

Triplet

Provides sharp images with minimum distortion. Three separate lenses bonded together to form one compound lens. Chrome plated finish. Complete with leather case.



Type	Magnification	Order Code OXD-316	Price/1 TB
Triplet	10x	-1500K	1029.00

Doublet

21mm diameter double lenses bonded together to form one compound lens. Provides a sharp magnified image with virtually no distortion.



Type	Magnification	Order Code OXD-316	Price/1 TB
Double	20x	-1520K	468.00

Hand Magnifiers

Available in 2x, 3x and 4x deluxe high power magnifications. 2x, 3x have chrome-plated brass frame and bakelite handle. 4x deluxe has a gilt-effect frame and hardwood handle.

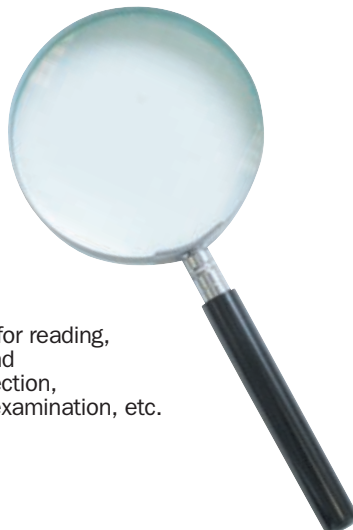

Suitable for reading, stamp and coin collection, product examination, etc.

Mag. Factor	Diameter	Order Code OXD-316	Price/1 TB
2x	89mm	-2500K	250.00
3x	50mm	-2520K	224.00
4x	65mm	-2600K	692.00



KENNEDY Eye Loupes

Manufactured from shock resistant plastic. Shatterproof lens. Ideal for jewellers, watchmakers, electronics and model makers.

Clear



Mag. Factor	Focal Length (mm)	Order Code KEN-518	Price/1 TB
10x	31 (1 1/4")	-6000K	135.00

Solid



Mag. Factor	Focal Length (mm)	Order Code KEN-518	Price/1 TB
10x	31 (1 1/4")	-5290K	121.00
4.0x	63 (2 1/2")	-5300K	63.00
3.5x	75 (3")	-5310K	70.00
3.0x	90 (3 1/2")	-5320K	76.00

Hand Magnifiers

Plastic lightweight magnifiers. Used to provide a clear crisp enlarged image. Used for inspection of finished parts, enlarging small text and pictures etc.



UP TO 100mm DIAMETER

Mag. Factor	Diameter	Order Code KEN-518	Price/1 TB
5x	50mm	-6040K	71.00
4x	75mm	-6060K	89.00
2x	100mm	-6080K	135.00

PRECISION EQUIPMENT

OXFORD PRECISION Bench Magnifiers

89mm (3½") diameter lens. 2x magnification. Chrome plated brass frame. 180mm flexible hose length permits viewing at any angle. Suitable for viewing work requiring high precision, reading, sewing, quality control, hobbies etc.



With Clamp

Black powder coated clamp provides stability and convenience. Portable and easy to clip onto a bench or table. **Clamping capacity:** 55mm.

With Stand

Cast horseshoe type stand provides stability and convenience.



Type	Order Code OXD-316	Price/1 TB
Clamp	-1100K	799.00
Stand	-1120K	794.00

LED Head Loupe with Removable LED Light & Interchangeable Lenses

This head loupe has a detachable LED light which can be removed to provide an independent source of light that has two magnets for attaching to steel objects. It can be worn with spectacles and has an adjustable headband for greater comfort and integral visor to cut out ambient light. It comes with four interchangeable lenses supplied with their own storage case. The lenses stay firmly in position when raised or lowered, leaving both hands free to work. Suitable for electrical service and assembly, model making and other applications where both hands are required to carry out finely detailed work.



Contents:

- 1x Head Loupe with removable LED light (batteries not included).
 - 1x Blanking plate for Visor when LED is removed.
 - 1x Box of four lenses:
- | | |
|------------------------------------|-------------|
| Magnification for Working Distance | |
| 1.2x | 520 - 620mm |
| 1.8x | 230 - 320mm |
| 2.5x | 150 - 250mm |
| 3.5x | 80 - 120mm |

Description	Order Code OXD-316	Price/1 TB
LED Head Loupe	-2560K	2184.00

EYE LOUPES & MAGNIFIERS

Illuminated Bench Magnifier - Adjustable Arm Type



Illuminated bench magnifier fitted with long life high efficiency 22W circular fluorescent daylight tube which provides perfect colour matching, low heat emission and greater eye comfort. Suitable for the workplace, hobbies or for people with limited vision.

- 127mm (5") diameter lens.
- 3x magnification.
- 1143mm (45") arm length.
- 180° arm adjustment.
- 160° lamp adjustment.



Accessories

Type	Order Code OXD-398	Price/1 TB
Fluorescent Tube 22W	-8600K	603.00

Illuminated Magnifier

Diameter	Order Code OXD-316	Price/1 TB
127mm	-1030K	4119.00

Illuminated Adjustable Stand Magnifier

With the lens tilted, small hand-held objects can be worked on or inspected. When the lens is parallel to the work surface anything laid beneath is in focus. Fitted with a long life high efficiency 22W circular daylight tube which provides perfect colour matching, low heat emission and greater eye comfort. Suitable for the workplace, hobbies or for people with limited vision.

- 127mm (5") diameter lens.
- 3x magnification.
- Fully adjustable.
- 220V.
- 170mm height adjustment.



Diameter	Order Code OXD-316	Price/1 TB
127mm	-1010K	8095.00

PRECISION EQUIPMENT

GROUP 318 BINOCULARS

RUTLAND III SPORT Compact Style Binoculars

Compact folding design for easy storage and transport. The high quality roof prisms and UV protective coated ocular lenses are housed in a polyurethane body coated in a shock absorbing high grip rubber armour. Diopter adjustment for improved image clarity and sharpness. To allow use with spectacles the soft rubber eye cups fold down. Accurate focusing of the binoculars is controlled by fingertip movement of the central focusing wheel. Integral neck strap eyelets and tripod mounting threaded recess point. Supplied complete with neck strap and cleaning cloth. Suitable for camping/hiking, outdoor spectator sports, nature viewing, theatre. Lead- and arsenic-free glass.



CR1025R

10 x 25

Diopter measurement



Product Number	Magnification	Order Code RTL-318	Price/1 TB
CR1025R	10 x 25	-1620K	1382.00



CR1025

10 x 25

Fold down eye cup



Diopter measurement



Product Number	Magnification	Order Code RTL-318	Price/1 TB
CR1025	10 x 25	-1230K	1879.00

Ultra Compact Binoculars

CP0821

The ultra compact design makes them ideal for use when storage space is at a premium. The high quality porro prism coated lenses are housed in a tough polyurethane body which is comfortable to hold. The diopter adjustment is easy to use and improves the image clarity and sharpness. Simple yet accurate focusing is achieved using fingertip control of the central focusing wheel. Supplied complete with case, neck strap and cleaning cloth.



8 x 21

Diopter measurement



Product Number	Magnification	Order Code RTL-318	Price/1 TB
CP0821	8 x 21	-1660K	1194.00

Traditional Style Binoculars

TP1050

The high quality porro prisms and UV protecting ruby coated ocular lenses are housed in a polyurethane body coated in a shock absorbing high grip rubber armour. Diopter adjustment for improved image clarity and sharpness. To allow use with spectacles the soft rubber eye cups fold down. Accurate focusing of the binoculars is controlled by fingertip movement of the central focusing wheel. Integral neck strap eyelets and tripod mounting threaded recess point. Supplied complete with lens cap, case, neck strap, and cleaning cloth. Suitable for camping/hiking, outdoor spectator sports, nature viewing. Lead- and arsenic-free glass.



10 x 50

Pupil distance scale

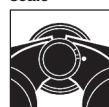

Tripod use



Fold down eye cup



Diopter measurement



Product Number	Magnification	Order Code RTL-318	Price/1 TB
TP1050	10 x 50	-1010K	3123.00

PRECISION EQUIPMENT

RUTLAND PRO Traditional Binoculars 7 x 50

TP0750

High quality lenses. Ocular objective lens caps. Diopter adjustment ring with index. Neck strap eyelets underneath. Central focusing wheel, tripod mounting with thread cover. Comfortable ergonomic design. Rubber armoured grip. Tripod mounting point.

Includes
Lens caps, case, neck strap, and cleaning cloth.



Prism type: Porro.
Magnification: 7x.
Objective lens: 50mm.
Angle of view: 6.8°.
Field of view at 1000m: 119m.
Exit pupil: 7mm.
Focusing method: Manual.
Closest focusing distance: 9m.
Dimensions: (W x H x D)
176 x 191 x 82mm.
Weight: 900g.



Product Number	Magnification x Lens Diameter	Order Code	Price/1 TB
TP0750	7 x 50	RTL-318	2421.00

Traditional Binoculars 10 x 42

TP1042

These Rutland Pro binoculars have a powerful 10 x magnification using a Porro prism, a 6° wide angle of view and a 42mm objective lens. These binoculars are powerful, yet have a narrow pupil distance making them ideal for the smaller user. The outer casing of the binoculars is designed for your comfort and covered with a protective rubber coating, to prevent damage from the occasional bump that may occur whilst in use. The point of focus is smoothly controlled with the central focusing wheel.

Includes
Lens caps, case, neck strap, and cleaning cloth.



Prism type: Porro.
Magnification: 10x.
Objective lens: 42mm.
Angle of view: 6°.
Field of view at 1000m: 105m.
Exit pupil: 4.2mm.
Focusing method: Manual.
Closest focusing distance: 4m.
Dimensions: (W x H x D)
110 x 168 x 65mm.
Weight: 775g.

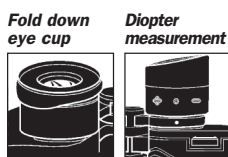

Product Number	Magnification x Lens Diameter	Order Code	Price/1 TB
TP1042	10 x 42	RTL-318	5301.00

Traditional Binoculars 10 x 60

TP1060

Ruby coated high quality precision lenses. Double diopter adjustment ring with index. Neck strap eyelets. Ocular lens caps. Central focusing wheel, tripod mounting thread cover. Objective lens caps. Rubber armoured ergonomically designed grip. Tripod mounting point.

Includes
Lens caps, case, neck strap and cleaning cloth.



Prism type: Porro.
Magnification: 10x.
Objective lens: 60mm.
Angle of view: 6.4°.
Field of view at 1000m: 108m.
Exit pupil: 6mm.
Focusing method: Manual.
Closest focusing distance: 10m.
Dimensions: (W x H x D)
200 x 200 x 85mm.
Weight: 1175g.

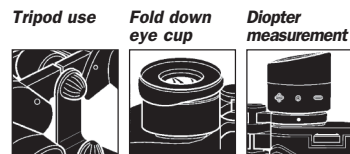

Product Number	Magnification x Lens Diameter	Order Code	Price/1 TB
TP1060	10 x 60	RTL-318	3745.00

Spotting Scope 18-36 x 50

SS3650

High quality precision lenses. Dust caps for ocular and objective lenses. Rubber armoured body protection. Complete with tripod and mounting point.

Includes
case with shoulder strap, and cleaning cloth. Bag has integral divider which separates the scope from the tripod to eliminate undue wear and tear.



Prism type: Porro.
Magnification: 18 - 36x.
Objective lens: 50mm.
Angle of view: 26 - 43°.
Field of view at 1000m: 23 - 38m.



Exit pupil: 1.5 - 4mm.
Focusing method: Manual.
Dimensions: (W x H x D)
380 x 360 x 330mm.
Weight: 1190g.

Product Number	Magnification x Lens Diameter	Order Code	Price/1 TB
SS3650	18-36 x 50	RTL-318	8239.00

PRODUCTS ARE ONLY AVAILABLE VIA YOUR DISTRIBUTOR

PRECISION EQUIPMENT



BCM400

Constructed to high optical and mechanical standards, the Oxford Biological Compound Microscope produces a clear and well defined two dimensional image. Designed for clinical examination and teaching demonstrations in laboratories, scientific research, colleges and the medical field. An ideal instrument for biological, bacteriological, pathological and pharmaceutical research. High quality prism providing a magnification of up to 400x. Fully coated optical system for improved light transmission and overall image quality. Objective lenses are of DIN standard, colour coded and click into position. Eyepiece with pointer. Monocular head which is inclined at 45° and can be rotated 360°. Separate fine and coarse focus by rack and pinion with a built-in slip clutch and tension adjustment. Built-in illuminator with a blue filter and a built in condenser lens ensuring optimal light effect for comfortable and clear viewing. Large die cast acid and reagent proof stage.

- Eyepiece:** Wide angle 10x, 18mm field with pointer.
- Tube length:** 160mm.
- Objective lenses:** Achromatic DIN 4x (0.10 numerical aperture).
- Objective lenses:** Achromatic DIN 10x (0.25 numerical aperture).
- Objective lenses:** Achromatic DIN 40xS (0.65 numerical aperture) retractable.
- Disc diaphragm:** 3mm, 4mm, 5mm, 8mm and 20mm calibrated dish type.
- Stage condenser:** Single lens 0.65 numerical aperture condenser.
- Fine focusing:** 0.0002mm.
- Stage:** 110 x 120mm.
- Lamp:** 220V/20W tungsten bulb.
- Fuse type:** Lamp T1A 250V, plug 3 amp.
- Voltage:** 220V ± 10%, 50/60Hz.
- Indoor working temperature:** . . 0°C - 40°C (32°F - 104°F).
- Maximum relative humidity:** . . 85%.
- Overall height:** 355mm.
- Net weight:** 2.832kg.



Part Number	Magnification	Order Code	Price/1 TB
BCM400	400x	OXD-318 -4100K	12875.00

Dissecting Stereo Metallurgical Microscope

DSM040

Constructed to high optical and mechanical standards, the Oxford Dissecting Stereo Microscope produces a clear and well defined three dimensional image. Designed for clinical examination and teaching demonstrations in laboratories, scientific research, colleges and the medical field. Provides true colour. High quality prism providing a magnification of up to 40x. Fully coated optical system for improved light transmission and overall image quality. Objective lenses are of DIN standard and click into position. Rubber eyecups and a diopter adjustment ring for clear and comfortable viewing. Rack and pinion focusing with built in slip clutch system. A choice of either upper or lower illumination or both. Pillar mounted body rotates 360° and can be removed and mounted on machine tools or laboratory apparatus. Binocular head which is inclined at 45°. Built-in illuminator.

- Eyepiece:** Wide angle 10x.
- Field of view:** 10mm at 2x/5mm at 4x.
- Diopter adjustment range:** . . ±5mm.
- Objective lenses:** Achromatic DIN 2x/object field 10mm.
- Objective lenses:** Achromatic DIN 4x /object field 5mm.
- Working distance:** 53mm.
- Interpupillary distance:** Adjustable between 55 - 75mm.
- Object plate:** 95mm black/white and opaque glass.
- Lamp:** 12V/10W festoon incandescent clear bulb.
- Fuse type:** Lamp T1A 250V, plug 3 amp.
- Voltage:** 220V ± 10%, 50/60Hz.
- Indoor working temperature:** . . 0°C - 40°C (32°F - 104°F).
- Maximum relative humidity:** . . 85%.
- Overall height:** 355mm.
- Net weight:** 2.359kg.



Part Number	Magnification	Order Code	Price/1 TB
DSM040	40x	OXD-318 -4400K	13905.00

PRECISION EQUIPMENT

HEIGHT GAUGES/DIAL DEPTH & THICKNESS GAUGES

OXFORD PRECISION Dual Counter Height Gauges

Used in conjunction with a granite or metal surface plate, the Oxford dual counter height gauge will give you the accuracy you need when laying out work prior to machining. The height gauge can also be used in much the same way as a caliper to help you determine the dimensions of a workpiece.

- Designed for accurate marking out and taking precise measurements.
- Measuring head positioned on sturdy twin columns providing highly repeatable height measurements and stability.
- Easy reading with dual directional negative and positive reading mechanical digital counters.
- Rotating dial face.
- Independently set the counters, to zero at any position.
- Large feed wheel for rapid and precise adjustment.
- Tungsten carbide tipped scriber for accurate marking out.
- Manufactured from durable stainless steel.



Reading
Inch: 0.001"/0.1"
Metric: 0.01mm/1mm

Range	Product Number	Range/Rev	Weight each	Order Code OXD-330	Price/1 TB
12"	DHG000	0.1"	4.25kg	-3120K	8498.00
24"	DHG000	0.1"	10.00kg	-3240K	14419.00
300mm	DHG000	1mm	4.25kg	-3620K	9785.00
600mm	DHG000	1mm	10.00kg	-3740K	15193.00

Bevel Protractor Set

For accurate angle measurement of machines, moulds and jigs. Made of polished and hardened stainless steel with magnifying lens for easy reading of vernier scale. Range is 4x 90° and accuracy is + ° or 5 minutes. Set includes: protractor head, 150mm (6"), 200mm (8") & 300mm (12") plain rules, height gauge and acute angle attachments.

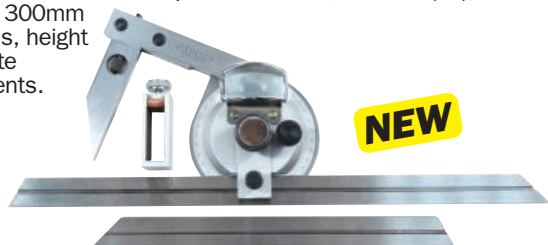

NEW

Description	Order Code OXD-330	Price/1 TB
Bevel Protractor Set	-9500K	8500.00

KENNEDY QUALITY INDUSTRIAL TOOLING 300mm/12" Multi-Function Combination Set -

Square head: With accurate machined faces, fixed angles of 45° and 90°, built-in spirit level, adjusting nut and scriber.
Protractor head: For measuring angles up to 180°, graduated to 1° with one machined face, three knurled securing/adjusting nuts.
Centre head: Offers a fixed 90° angle, for finding the centre of round bar stock up to 120mm diameter.
300/12" rule: Hardened stainless steel with graduations in 0.5mm and 1/64".

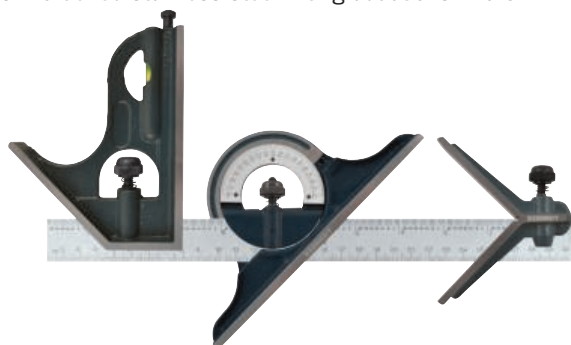

Model Number	Description	Order Code KEN-330	Price/1 TB
KCS300	Combination Set	-3250K	9018.00

Leg Type Dial Calipers

Leg type dial calipers used for measuring diameters and narrow grooves in hard to reach places.

Internal specifications: range: 55 - 75mm, graduation: .01mm, groove depth: 8mm, groove width: 3mm, maximum reach: 100mm.
External specifications: range: 0 - 20mm, graduation: 0.01mm, groove depth: 6mm, groove width: 3mm, throat depth: 60mm.



Type	Groove Depth	Reach/Depth	Order Code OXD-330	Price/1 TB
External	6mm	60mm	-0600K	5408.00
Internal	8mm	100mm	-0750K	5665.00

Dial Thickness Gauge

For quickly measuring the thickness of paper, film, leather, rubber etc. The spindle is moved using the thumb lever. With adjustable bezel. Measuring faces are made of high grade tool steel, hardened, ground and lapped for accuracy. Thumb lever raises spindle to allow for workpiece insertion.

Range: 0 - 10mm.
Graduations: 0.01mm.
Throat depth: 30mm.
Accuracy: ±0.02mm.



Type	Groove Depth	Reach/Depth	Weight each	Order Code OXD-330	Price/1 TB
External	6mm	60mm	236g	-0100K	2632.00

OXFORD PRECISION 12"/300mm Multi-Function Combination Set

Fully hardened and ground datum faces to resist wear. Centrally mounted protractor vial allows unrestricted viewing. Precision rules with deeply etched graduations on both sides for ease of reading and long life.

Protractor: Full 360° scale plate, graduated 0 - 180° - 0, includes vial.
Square head: Offers the following fixed angles: 45° and 90°.
Centre head: Offers a fixed 90° angle, for finding the centre of round bar stock up to 120mm diameter.

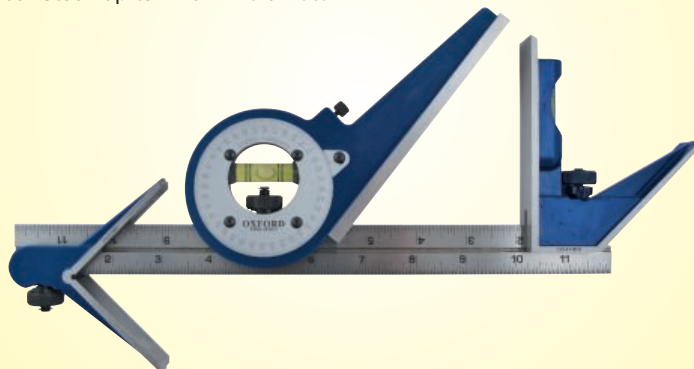

Description	Order Code OXD-330	Price/1 TB
Combination Set	-3850K	5665.00

PRODUCTS ARE ONLY AVAILABLE VIA YOUR DISTRIBUTOR

GROUP 330 DIAL CALIPERS

KENNEDY *Dial Calipers*
QUALITY INDUSTRIAL TOOLING



Rack covers prevent dust from fouling teeth of racks. All measuring faces are precision ground and micro lapped for absolute inside, outside, depth and step readings. Manufactured to **DIN 862**.

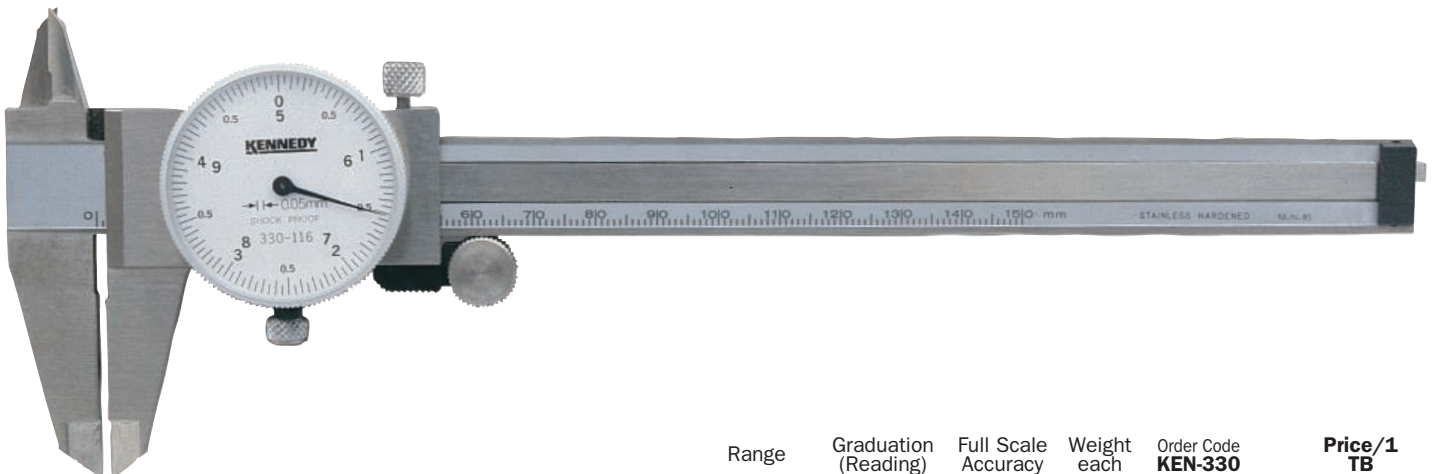

Range	Graduation (Reading)	Full Scale Accuracy	Weight each	Order Code	Price/1 TB
150mm	0.05mm	±.05mm	320g	-1160K	2627.00

OXFORD PRECISION *Dial Calipers*



Rack covers prevent dust from fouling teeth of racks. All measuring faces are precision ground and micro lapped for absolute inside, outside, depth and step readings. Manufactured to **DIN 862**.

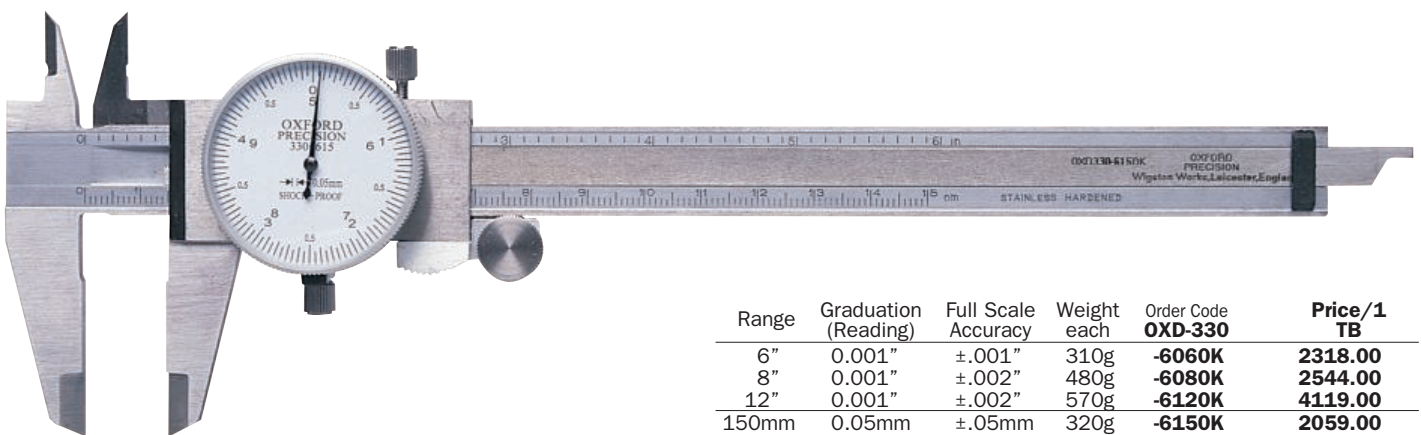

Range	Graduation (Reading)	Full Scale Accuracy	Weight each	Order Code	Price/1 TB
6"	0.001"	±.001"	310g	-6060K	2318.00
8"	0.001"	±.002"	480g	-6080K	2544.00
12"	0.001"	±.002"	570g	-6120K	4119.00
150mm	0.05mm	±.05mm	320g	-6150K	2059.00
200mm	0.05mm	±.05mm	530g	-6200K	2730.00
300mm	0.05mm	±.05mm	750g	-6300K	4635.00

SENATOR *Plastic Dial Caliper - Metric*
QUALITY TOOLING



Accurate four way measurement: internal, external, step and depth. Sliding jaw lock. Manufactured from high strength, lightweight polymide plastic.

Accuracy: ±0.1mm.

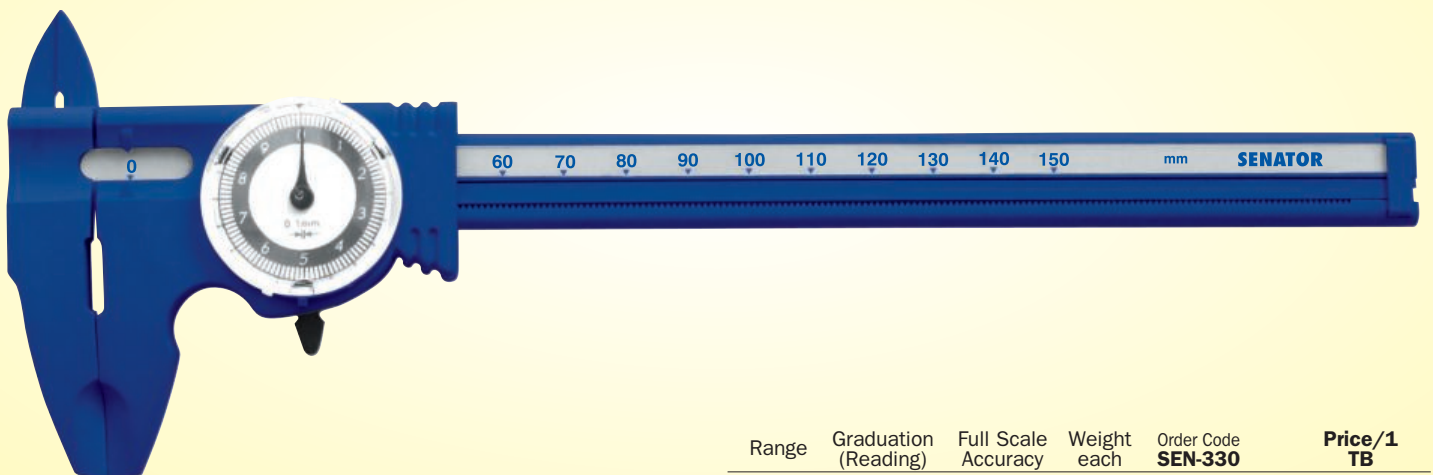

Range	Graduation (Reading)	Full Scale Accuracy	Weight each	Order Code	Price/1 TB
150mm	0.1mm	±.0.1mm	175g	-6100K	205.00

PRECISION EQUIPMENT

KENNEDY *Fine Adjustment Vernier Calipers*
QUALITY INDUSTRIAL TOOLING

Incorporating Quadri feature - gives outside, inside, depth and step readings. Fine adjustment feature allows improved sensitivity of slider movement. 14° vernier face angle reduces parallax. Satin chrome finish with clear easy read graduations.

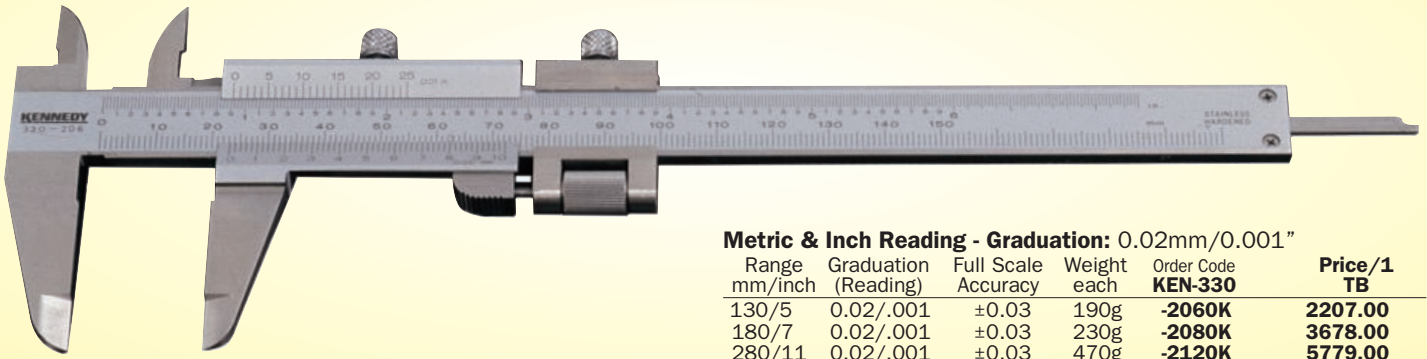

Metric & Inch Reading - Graduation: 0.02mm/0.001"

Range mm/inch	Graduation (Reading)	Full Scale Accuracy	Weight each	Order Code KEN-330	Price/1 TB
130/5	0.02/.001	±0.03	190g	-2060K	2207.00
180/7	0.02/.001	±0.03	230g	-2080K	3678.00
280/11	0.02/.001	±0.03	470g	-2120K	5779.00

OXFORD PRECISION *Standard Vernier Calipers*

Give four types of reading - inside, outside, depth and step. Dual reading scale (metric and inch) with 14° bevelled vernier scale for reduced parallax reading error and knurled locking nut.

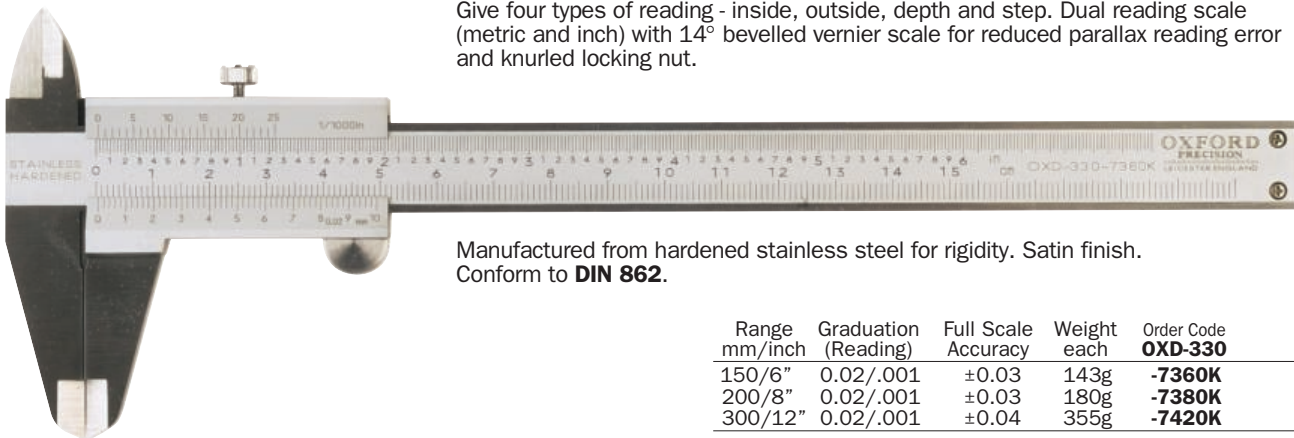

Manufactured from hardened stainless steel for rigidity. Satin finish. Conform to **DIN 862**.

Range mm/inch	Graduation (Reading)	Full Scale Accuracy	Weight each	Order Code OXD-330	Price/1 TB
150/6"	0.02/.001	±0.03	143g	-7360K	2059.00
200/8"	0.02/.001	±0.03	180g	-7380K	2711.00
300/12"	0.02/.001	±0.04	355g	-7420K	5742.00

Fine Adjustment Vernier Calipers

Give four types of reading, inside, outside, depth and step. Dual reading scale (metric and inch) with 14° bevelled vernier scale for reduced parallax reading error, fine adjustment assembly and knurled locking nut.

Manufactured from hardened stainless steel for rigidity with satin finish. Conforms to **DIN 862**.

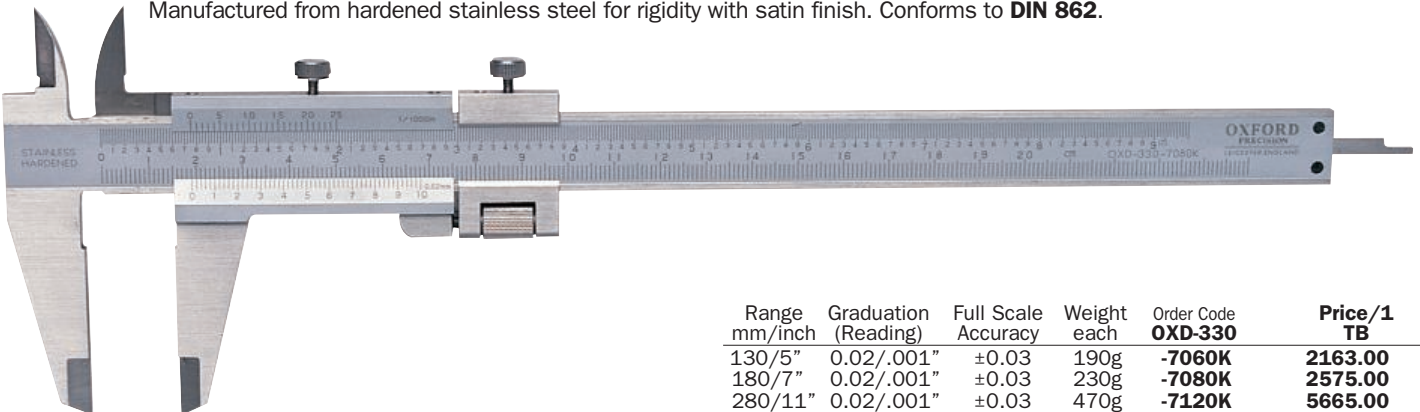

Range mm/inch	Graduation (Reading)	Full Scale Accuracy	Weight each	Order Code OXD-330	Price/1 TB
130/5"	0.02/.001"	±0.03	190g	-7060K	2163.00
180/7"	0.02/.001"	±0.03	230g	-7080K	2575.00
280/11"	0.02/.001"	±0.03	470g	-7120K	5665.00

Heavy Duty Vernier Calipers

Give inside and outside readings. Dual reading scale (metric and inch) with 14° bevelled vernier scale for reduced parallax reading error, fine adjustment assembly and knurled locking nut. Internal reading edges have rounded faces for accurate bore measurement. Manufactured from hardened stainless steel.



Range mm/inch	Graduation (Reading)	Full Scale Accuracy	Weight each	Order Code OXD-330	Price/1 TB
450/18"	0.02/0.001	±0.1	2.25kg	-7180K	9219.00
600/24"	0.02/0.001	±0.1	2.40kg	-7240K	10285.00

Depth Gauge Attachment

Stainless steel depth gauge attachment for use with 150 and 200mm (6" and 8") depth gauges. 16mm vernier recess width with knurled locking nut.

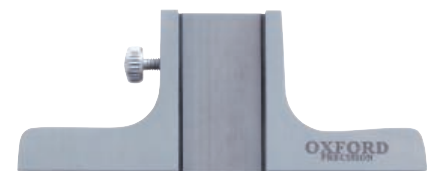

Size	Models suited (mm)	Weight each	Order Code OXD-330	Price/1 TB
75mm	150/200	45g	-9600K	1035.00

KENNEDY ABSolute Digital Electronic Calipers
QUALITY INDUSTRIAL TOOLING



Modern design with a knurled thumb wheel for easy use when taking internal and external depth and step measurements. Dual readout giving instant inch/metric conversion at the touch of a button. Zero reset at any point, large clear display, error-free operation, fast response speed. Non-output type. **Resolution:** 0.01mm/0.0005".

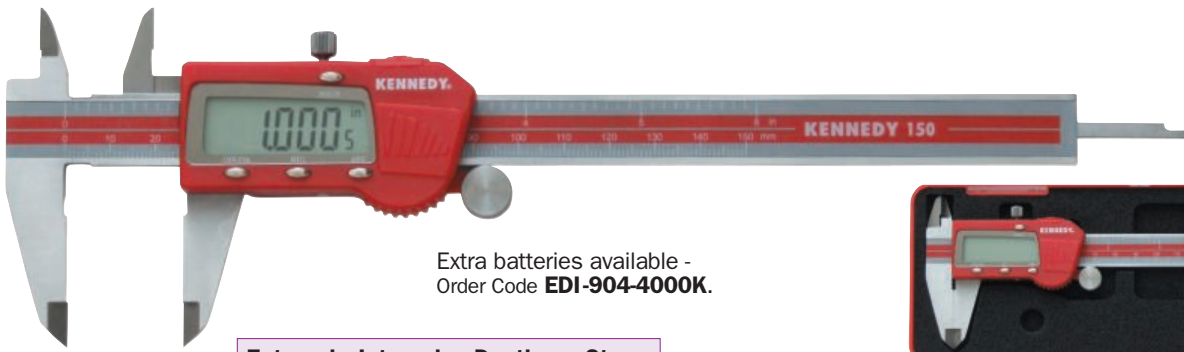

Extra batteries available -
 Order Code **EDI-904-4000K**.

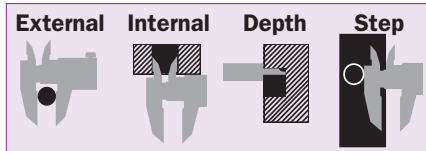

Range	Accuracy (mm)	Weight each	Order Code KEN-331	Price/1 TB
150mm/ 6"	±0.03	360g	-2260K	1906.00
200mm/ 8"	±0.03	425g	-2280K	2704.00
300mm/12"	±0.03	805g	-2320K	5953.00

OXFORD PRECISION Precision ABS Digital Calipers



Precision ABSolute digital calipers have a thumb wheel for precise movement and a useful locking screw for checking repeat measurements. A measurement can be converted between inch/metric at the touch of a button. Non-output type.

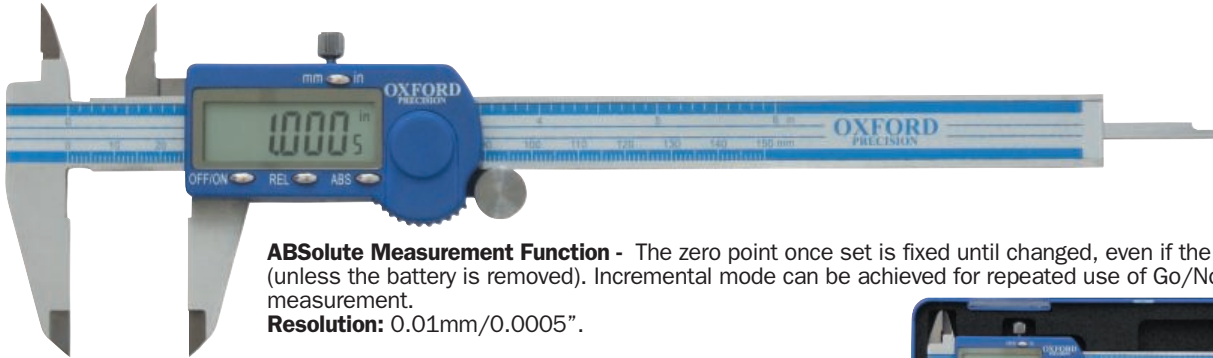

ABSolute Measurement Function - The zero point once set is fixed until changed, even if the caliper is turned off (unless the battery is removed). Incremental mode can be achieved for repeated use of Go/No-Go measurement.
Resolution: 0.01mm/0.0005".

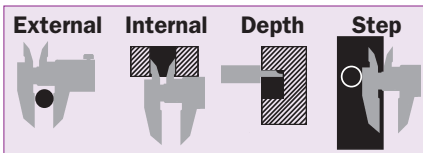

Extra batteries available -
 Order Code **EDI-904-4000K**.

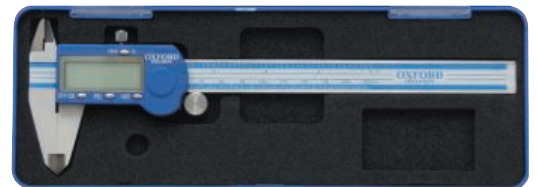

Range	Accuracy (mm)	Weight each	Order Code OXD-331	Price/1 TB
150mm/ 6"	±0.03	360g	-2260K	1792.00
200mm/ 8"	±0.03	460g	-2280K	2603.00
300mm/12"	±0.03	810g	-2320K	5525.00

SENATOR Digital Calipers
QUALITY TOOLING



Large display for clarity. Fast response speed. Zero reset. Dual readout mm/inch. Multi-use, inside, outside, depth and step measuring. Knurled thumb grip for precise movement.

Resolution: 0.01mm/0.0005"
Accuracy: ±0.03mm/±0.001"

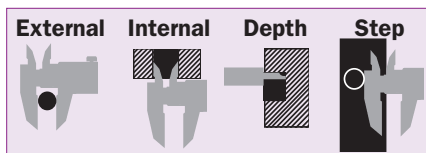
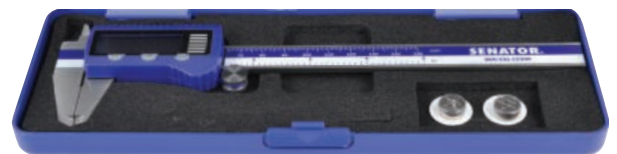
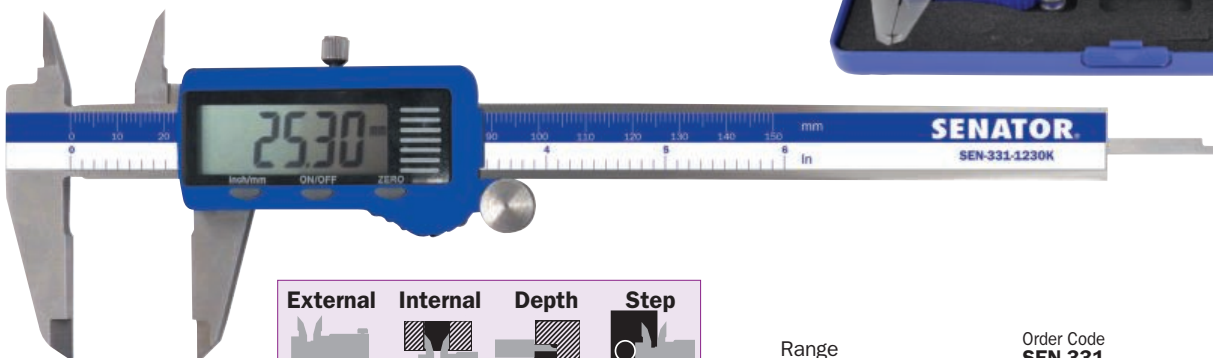

Range	Order Code SEN-331	Price/1 TB
150mm/6"	-1230K	1570.00
200mm/8"	-1250K	2274.00
300mm/12"	-1290K	5141.00

KENNEDY *Coolant-Proof*
QUALITY INDUSTRIAL TOOLING **IP67 Digital Caliper**

Available in a range of sizes, this digital caliper is coolant, water and dust proof to IP67 level. It has a large LCD display, fast response speed, dual readout (mm/inch) and can be used for inside, outside, depth and step measuring. Also enables absolute and relative reading.

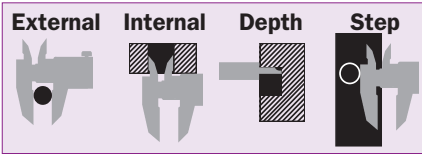
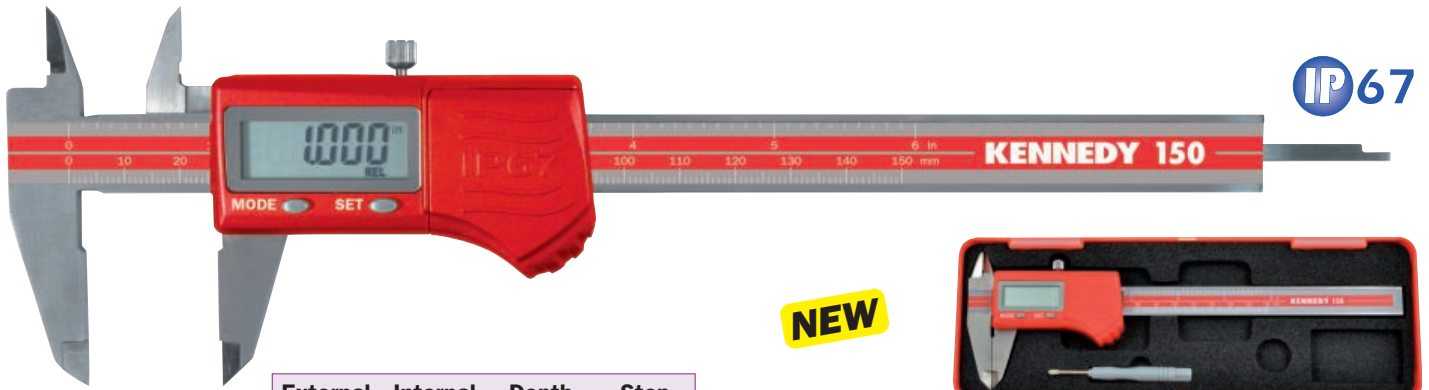

Extra batteries available -
Order Code
EDI-904-4000K.

NEW

Range	Accuracy (mm)	Weight each	Order Code KEN-331	Price/1 TB
150mm/6"	±.02	400g	-1200K	5562.00
200mm/8"	±.02	500g	-2270K	7571.00
300mm/12"	±.02	750g	-2310K	10558.00

SENATOR *Digital*
QUALITY TOOLING **Caliper**

Carbon Fibre Digital Electronic Caliper - 150mm/6"
Carbon fibre composite shaft. Measures outside, inside, step and depth. Uses one SR44 battery.

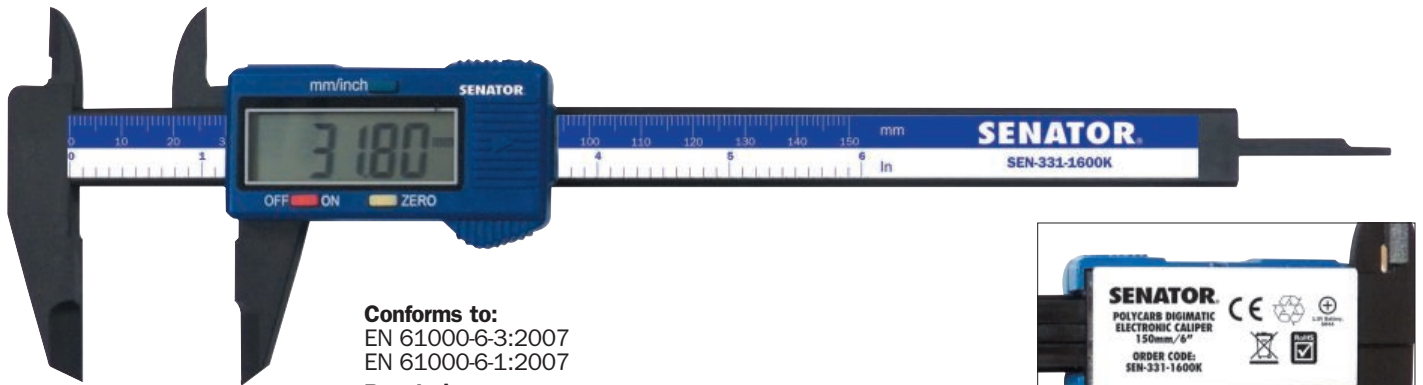

Conforms to:
EN 61000-6-3:2007
EN 61000-6-1:2007
Resolution:
0.01mm/0.0005"
Accuracy:
±0.02mm/±0.001"

Range	Resolution	Accuracy (mm)	Weight each	Order Code SEN-331	Price/1 TB
150mm/6"	0.01mm	±0.02	360g	-1600K	866.00

OXFORD *0 - 150mm/0 - 6"*
PRECISION **Digital Depth Gauge**

Easy handling with mm/inch measurement, large digital display. External readings with zero set at any point fitted with a thumb wheel for greater accuracy.

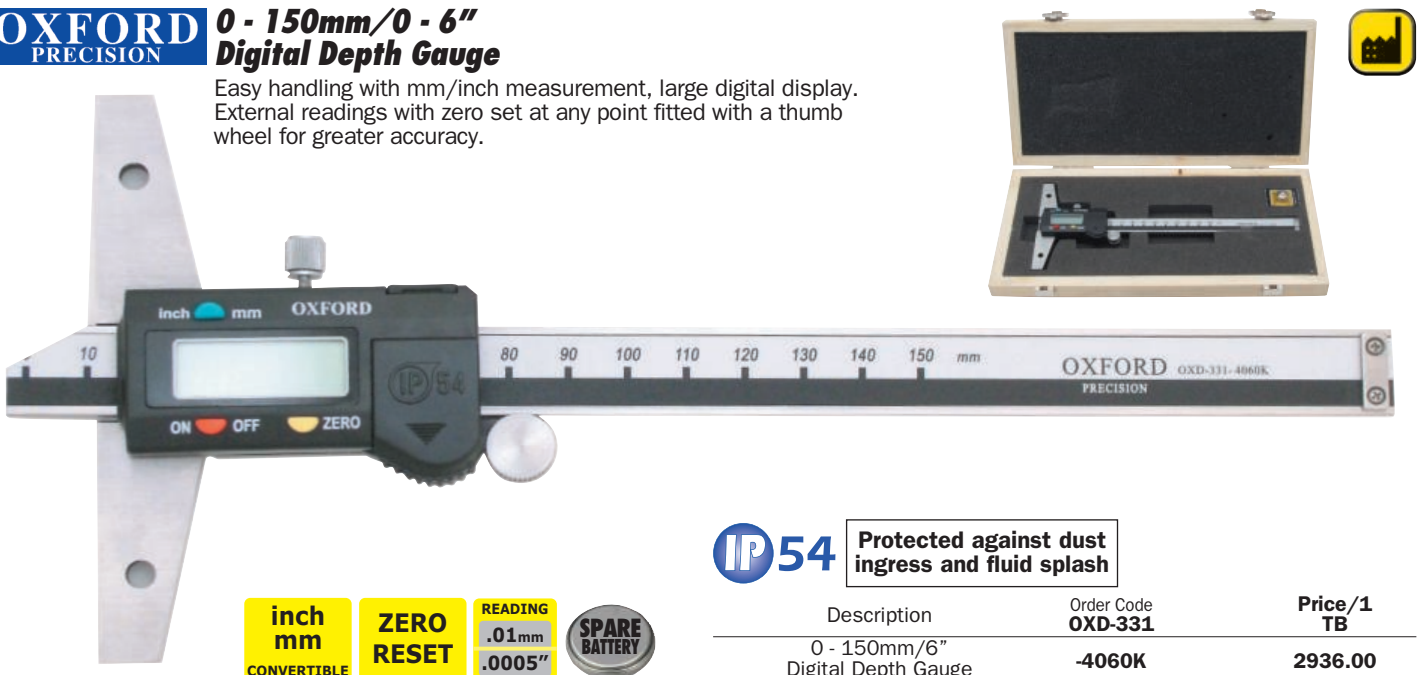

IP54 Protected against dust ingress and fluid splash

Description	Order Code OXD-331	Price/1 TB
0 - 150mm/6" Digital Depth Gauge	-4060K	2936.00

PRODUCTS ARE ONLY AVAILABLE VIA YOUR DISTRIBUTOR

GROUP 331 DIGITAL INDICATORS

OXFORD PRECISION External Digital Micrometer

External Digital Micrometer 0-25mm/0-1"

Oxford external digital micrometer with large digital display, quick response speed and zero set at any point. Metric/inch measurement. Can be connected to a PC serial port via the SPC cable (supplied separately). **IP65** rating.

- Easy handling
- mm/Inch measurements
- Ball end cap for measuring curved surfaces
- Large digital display
- Quick response speed
- Zero set at any point
- **IP65** rating

Coolant Proof

IP65



Range	Order Code	Price/1 TB
0 - 25mm/0 - 1"	OXD-331	3789.00

Digital Electronic External Micrometer

Easy handling with a large digital display, quick response speed and zero set at any point. Metric/inch measurement. The micrometer can be connected to a PC serial port by the SPC cable provided. **IP54** rating.

Range: 0 - 25mm/0 - 1".

Resolution: 0.001mm/0.00005".

Measuring force: 5 - 10N.

Accuracy: -0.004mm.

IP54

Protected against dust ingress and fluid splash



With SPC Data Output

Range	Resolution	Order Code	Price/1 TB
0 - 25mm/0 - 1"	0.001mm/0.0005"	-5010K	7960.00



OXFORD PRECISION IDM Digital Indicator

Features: Easy to use with clear digital LCD display. Large, easy-read 7.5mm LCD display. Soft-key touch for operator comfort, superior construction quality. **Response speed:** ≤0.5m/s. Auto power off.

Type IDM
Inch/metric conversion, zero reset, data hold, min. max display, fast display, auto power off.



IP54
Protected against dust ingress and fluid splash

Description	Order Code	Price/1 TB
IDM Digital Indicator	-6020K	8772.00

IDS Digital Indicator

Features: Easy to use with clear digital LCD display. Large, easy-read 7.5mm LCD display. Soft-key touch for operator comfort. Superior construction quality.

Response speed: ≤0.5m/s. Auto power off.



IP54
Protected against dust ingress and fluid splash

Description	Order Code	Price/1 TB
IDS Digital Indicator	-6010K	4443.00

KENNEDY Digital Protractor

PDV360
This digital protractor has a range of 360° split into 4 x 90° quadrants. It is simple to calibrate and the intelligent display changes orientation at 90° and 270° to remain readable. It has a 'V' groove on the top and bottom for easy placement on acute angled or cylindrical objects. 3V lithium battery gives up to 2000 hours use. Complete with a leatherette pouch that has a belt loop. **Resolution:** 0.1°



Range	Weight each	Order Code	Price/1 TB
360° (90° x 4)	10.2kg	-4020K	2869.00

PRECISION EQUIPMENT

KENNEDY Permanent **Mag Stand**
QUALITY INDUSTRIAL TOOLING

Mini-Mag Stand

With one magnetic face.
Light duty with standard clamp, 30mm diameter keeper.

Mounts:

1/4" I/D lug, stem/spigot diameter: 5/16".

Column height x dia.:

120 x 6.3mm.

Magnetic pull:

14.75kg.

Base dimensions:

30 x 35mm.



Overall Height	Weight each	Order Code	Price/1 TB
150mm	314g	-2010K	1082.00

Lever Switchable Universal 2 Mag Stand

With two magnetic faces and large vee.



Heavy duty with universal clamp.

Mounts:

1/4" I/D lug, stem/spigot diameter:

4mm, 8mm,

3/8" without bush.

Overall Height	Weight each	Order Code	Price/1 TB
230mm	1.2kg	-2030K	2490.00

Lever Switchable Fine Adjustable 2 Mag Stand

With two magnetic faces and large vee. Heavy duty with universal clamp and fine adjustment.

Mounts:

1/4" I/D lug, stem/spigot diameter:

4mm, 8mm,

3/8" without bush.

Base dimensions:

60 x 50 x 55mm.

Column height x dia.:

175 x 12mm.

Crossbar length x dia.:

165 x 10mm.

Magnetic pull: 50kg.



Overall Height	Weight each	Order Code	Price/1 TB
230mm	1.2kg	-2050K	2706.00

MAGNETIC BASES & COMPARATOR STANDS

OXFORD Universal 2 **Mag Stand**
PRECISION

Lever type, two magnetic faces and large vee. With universal clamp.

Mounts: 1/4" I/D lug, stem/spigot diameter: 4mm, 8mm, 3/8" without bush.

Base dimensions: 60 x 65 x 55mm.

Column height x dia.: 175 x 12mm.

Crossbar length x dia.: 160 x 10.0mm.

Magnetic pull: 50kg.



Overall Height	Weight each	Order Code	Price/1 TB
230mm	1.20kg	-7030K	1008.00

Fine Adjustment 2 Mag Stand

Lever type two magnetic faces and large vee. Universal clamp.

Mounts:

1/4" I/D lug, stem/spigot diameter: 4mm, 8mm, 3/8" without bush.

Base dimensions: 60 x 50 x 55mm.

Column height x dia.: 175 x 12mm.

Crossbar length x dia.: 160 x 10.0mm.

Magnetic pull: 50kg.



Overall Height	Weight each	Order Code	Price/1 TB
230mm	1.20kg	-7050K	1061.00

Universal 4 Mag Stand

With four magnetic faces, one at 45°. Universal clamp.

Mounts:

1/4" I/D lug, stem/spigot diameter: 1/8",

5/16" and 3/8".



Base dimensions:

60 x 50 x 55mm.

Column height x dia.:

175 x 12mm.

Crossbar x dia.:

160 x 10.0mm.

Magnetic pull: 30kg.

Overall Height	Weight each	Order Code	Price/1 TB
230mm	1.20kg	-7100K	1545.00

Compact 4 Mag Stand

With four magnetic faces, one at 45°. Standard clamp.

Mounts:

1/4" I/D lug, stem/spigot diameter: 5/16".



Base dimensions:

50 x 50 x 76mm.

Column height x dia.:

185 x 12mm.

Crossbar length x dia.:

165 x 6.3mm.

Magnetic pull: 30kg.

Overall Height	Weight each	Order Code	Price/1 TB
280mm	1.90kg	-7080K	1906.00

Fine Adjusting 4 Mag Stand

With four magnetic faces, one at 45°. Heavy duty with universal clamp and fine adjustment.

Mounts:

1/4" I/D lug, stem/spigot diameter:

1/8", 1/4".



Base dimensions:

64 x 64 x 76mm.

Column height x diameter:

175 x 12mm.

Crossbar length x diameter:

165 x 10.0mm.

Magnetic pull: 80kg.

Overall Height	Weight each	Order Code	Price/1 TB
280mm	1.90kg	-2060K	6818.00

PRODUCTS ARE ONLY AVAILABLE VIA YOUR DISTRIBUTOR

PRECISION EQUIPMENT



Major 4 Mag Stand

With four magnetic faces, one at 45°. Heavy duty with universal clamp.

Mounts: 1/4" I/D lug, stem/spigot diameter: 1/4", 5/16".

Base dimensions: 64 x 64 x 76mm.

Column height x diameter: 266 x 20mm.

Crossbar length x diameter: 200 x 14.0mm.

Magnetic pull: 80kg.



Overall Height	Weight each	Order Code KEN-333	Price/1 TB
380mm	3.00kg	-2070K	12987.00

Compact 4 Mag Stand

With four magnetic faces, one at 45°. Medium duty with standard clamp.

Mounts: 1/4" I/D lug, stem/spigot diameter: 5/16".

Base dimensions: 50 x 50 x 76mm.

Column height x diameter: 185 x 12mm.

Crossbar length x diameter: 150 x 6.3mm.

Magnetic pull: 30kg.



Overall Height	Weight each	Order Code KEN-333	Price/1 TB
273mm	0.89kg	-2080K	4762.00

Universal 4 Mag Stand

With four magnetic faces, one at 45°. Heavy duty with universal clamp.

Mounts: 1/4" I/D lug, stem/spigot diameter: 1/8", 5/16" and 3/8".

Base dimensions: 48 x 40 x 50mm.

Column height x diameter: 175 x 12mm.

Crossbar length x diameter: 165 x 10.0mm.

Magnetic pull: 30kg.



Overall Height	Weight each	Order Code KEN-333	Price/1 TB
227mm	0.90kg	-2100K	4113.00

Lever Switchable Mini Elbow Joint 2 Mag Stand

Compact in design, this stand has a magnetic pull of 40kg with positive switching, fully adjustable joints and slotted 'V' groove.

Mounts: 1/4" I/D lug, dovetail stem/spigot diameter: 5/16".

Base dimensions: 36 x 30 x 35mm.

Column height x diameter: Up to 150 x 12mm.

Magnetic pull: 40kg.



Mini Elbow Joint	Weight each	Order Code KEN-333	Price/1 TB
2 Mag	420g	-2140K	5682.00

Lever Switchable Large Elbow Joint 2 Mag Stand

Large stand with two powerful magnetic faces producing a magnetic pull of 80kg. Positive switching, fully adjustable joints and slotted 'V' groove for versatility.

Mounts: 1/4" I/D lug, dovetail stem/spigot diameter: 5/16".

Base dimensions: 60 x 50 x 55mm.

Column height x diameter: Up to 300 x 17mm.

Magnetic pull: 80kg.



Large Elbow Joint	Weight each	Order Code KEN-333	Price/1 TB
2 Mag	1.62kg	-2150K	7034.00

Lever Switchable Elbow Joint 2 Mag Stand

With two magnetic faces and large vee. Medium duty special clamp with fine adjustment.

Mounts: 1/4" I/D lug, dovetail stem/spigot diameter: 5/16".

Base dimensions: 60 x 50 x 55mm.

Column height x diameter: Up to 280 x 15mm.

Magnetic pull: 50kg.



Elbow Joint	Weight each	Order Code KEN-333	Price/1 TB
2 Mag	1.2kg	-2110K	5195.00

Lever Type Base - 50kg

Fitted as standard to KEN-333-2030K, -2050K and -2110K two magnetic faces, bottom and back face. Large vee for curved surfaces.

Threaded: M8 x 1.25mm.

Base dimensions: 60 x 50 x 55mm.

Magnetic pull: 50kg.



Magnetic Pull	Weight each	Order Code KEN-333	Price/1 TB
50kg	850g	-2240K	2003.00

Push Button Base - 30kg

Fitted as standard to KEN-333-2080K and -2100K. Four magnetic faces, bottom, sides and 45° angle face for curved surfaces.

Threaded: M8 x 1.25mm.

Magnetic pull: 30kg.



Magnetic Pull	Weight each	Order Code KEN-333	Price/1 TB
30kg	850g	-2220K	3085.00

Push Button Base - 80kg

Fitted as standard to KEN-333-2060K and -2070K. Four magnetic faces, bottom, sides and 45° angle face for curved surfaces.

Threaded: M8 x 1.25mm.

Magnetic pull: 80kg.



Magnetic Pull	Weight each	Order Code KEN-333	Price/1 TB
80kg	850g	-2200K	10815.00

PRECISION EQUIPMENT



KENNEDY *Magnetic Stand Fittings*
QUALITY INDUSTRIAL TOOLING

All main columns are threaded M8 x 1.25mm and are interchangeable with Kennedy, Oxford, Mitutoyo etc. base units except mini-mag (M6 x 1mm) also suitable for incorporating into special fixtures or threaded pot magnets.

Light Duty Fitment - Plain

Fitted as standard to **KEN-333-2010K**.

Column: 6.3 x 120mm.
Threaded: M6 x 1mm.



6.3mm Standard Clamp To Suit	Weight each	Order Code KEN-333	Price/1 TB
1/4" I/D Lug, Stem/Spigot Dia. 5/16"	90g	-2500K	975.00

Heavy Duty Fitment - Fine Adjusting

Fitted as standard to **KEN-333-2060K** and **KEN-333-2050K**.



Column: 12 x 175mm.
Cross bar: 10 x 165mm with fine adjustment.
Threaded: M8 x 1.25mm.

10mm Universal Clamp To Suit	Weight each	Order Code KEN-333	Price/1 TB
1/4" I/D Lug, Stem/Spigot Dia. 1/8", 1/4", 5/16" & 3/8"	442g	-2400K	1516.00

Spare Knuckle Assemblies

For connecting columns and crossbars

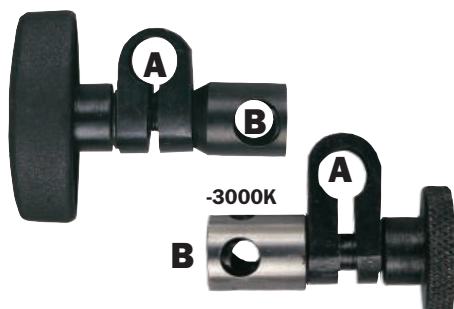

Accepts A & B	Weight each	Order Code KEN-333	Price/1 TB
5/16" & 1/4" O/D	50g	-3000K	361.00
12 & 10mm O/D	60g	-2920K	493.00

MAGNETIC BASES & COMPARATOR STANDS

Medium Duty Fitment - Plain

Fitted as standard to **KEN-333-2080K**.

Column: 12 x 185mm.
Cross bar: 6.3 x 150mm.
Threaded: M8 x 1.25mm.



6.3mm Standard Clamp To Suit	Weight each	Order Code KEN-333	Price/1 TB
1/4" I/D Lug, Stem/Spigot Dia. 5/16"	420g	-2460K	1624.00

Heavy Duty Fitment - Plain

Fitted as standard to **KEN-333-2100K** and **KEN-333-2030K**.



Column: 12 x 175mm.
Cross bar: 10 x 165mm.
Threaded: M8 x 1.25mm.

10mm Universal Clamp To Suit	Weight each	Order Code KEN-333	Price/1 TB
1/4" I/D Lug, Stem/Spigot Dia. 1/8", 1/4", 5/16" & 3/8"	400g	-2420K	1407.00

Crossbar Assembly

With lug adaptor. 1/4" I/D lug

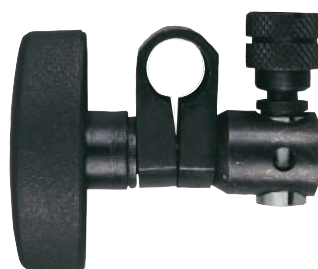

Accepts	Weight each	Order Code KEN-333	Price/1 TB
4, 8, & 10mm Spigot To Fit 10mm Bar	85g	-3020K	396.00
4, 6 & 8mm Spigot To Fit 12mm Bar	85g	-3040K	670.00

Medium Duty Fitment - 3 Point

Fitted as standard to **KEN-333-2110K**.

3 point adjustable column: 15 x 280mm max.
Threaded: M8 x 1.25mm.



3 Point Special Clamp To Suit	Weight each	Order Code KEN-333	Price/1 TB
1/4" I/D Lug, Dovetails Stem/Spigot Dia. 5/16"	312g	-2480K	1895.00

Heavy Duty Fitment - Plain

Fitted as standard to **KEN-333-2070K**.

Column: 20 x 266mm.
Cross bar: 12 x 200mm.
Threaded: M8 x 1.25mm.



14mm Universal Clamp To Suit	Weight each	Order Code KEN-333	Price/1 TB
1/4" I/D Lug, Stem/Spigot Dia. 1/8", 1/4", 5/16" & 3/8"	1450g	-2440K	5665.00

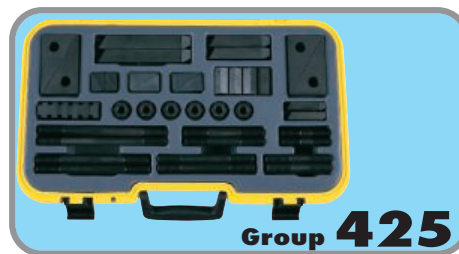

GROUP 335 BORE GAUGES

OXFORD PRECISION Dial Indicating Bore Gauges

29mm 1 1/8" Dial Diameter

Suitable for rapid, accurate measurement of size, concentricity, wear, taper, etc., in a wide range of bores. For workshop and inspection use. All models have one fixed and one moving anvil and a self-adjusting centre shoe. A 'datum point' can be set by using a setting ring of a known diameter or a micrometer. 'Zero' the gauge to this datum point by rotating the bezel to align 'zero' with the indicator. To check a bore is within tolerance, the limit hands can be fixed as required. All anvils are spring loaded to expand into the bore. For accurate reading ensure the stem of the gauge is parallel to the axis of the bore. This can be checked by 'rocking' the gauge back and forth until the smallest diameter is found. All models have inter-changeable anvils to cover a range of bore sizes.



Supplied in a tough hard case.

Type	Graduation	Face Dial	Reading	Travel Per Rev	Total Travel
Metric	0.01mm	57mm	0-100	1mm	3mm
Inch	0.0005"	2 3/16"	0-25-0	0.050"	0.25"

Range	Bore Depth	Weight each	Order Code	Price/1 TB
18 - 35	200	0.58kg	-1400K	4611.00
35 - 50	240	0.95kg	-1450K	4735.00
50 - 150	240	1.28kg	-1500K	4923.00
0.7 - 1.5"	7 1/2"	0.53kg	-1000K	4235.00
1.4 - 2.4"	9"	0.90kg	-1050K	4658.00
2.0 - 6.0"	9"	1.20kg	-1100K	4923.00

3 Point Bore Micrometer Sets

Designed to self-centre, for accurate measuring of bores. Extension rods for measuring 170mm deep on 11 - 20mm and 220mm deep on 20 - 40mm. Satin finish, fitted with knurled ratchet stop.



NEW

OXD-335-2520K

Micrometers: 11 - 14mm, 14 - 17mm, 17 - 20mm. Calibration ring: 11 and 17mm, slotted screwdriver and spanners x2.

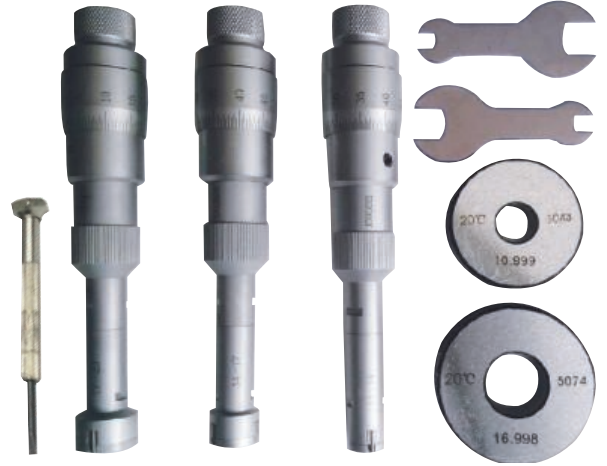

OXD-335-2530K

Micrometers: 20 - 25mm, 25 - 30mm, 30 - 35mm, 35 - 40mm. Calibration ring: 25 and 35mm, slotted screwdriver and spanners x2.



Range (mm)	Number of Micrometers	Weight each	Order Code OXD-335	Price/1 TB
11 - 20mm	3	1.05kg	-2520K	23690.00
20 - 40mm	4	2.60kg	-2530K	38110.00

PRECISION EQUIPMENT



OXFORD Enamelled Frame External Micrometers
PRECISION

With enamelled frame and tungsten carbide tipped anvils. High quality fitted metal case with adjusting spanner. Sizes 25 - 50mm/1 - 2" and over supplied with setting standard. Manufactured to BS 870. All supplied in a impact resistant fitted plastic case.

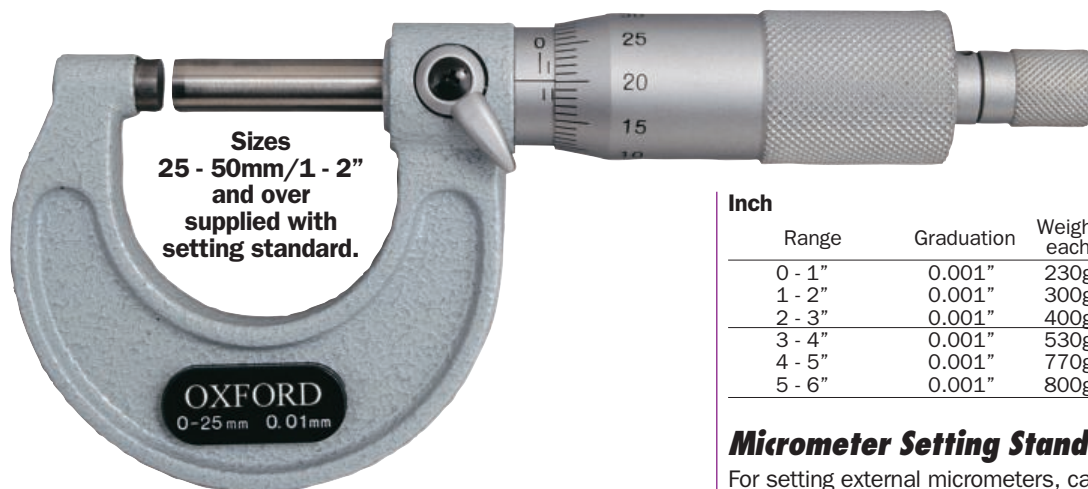

Sizes 25 - 50mm/1 - 2" and over supplied with setting standard.



Supplied in case



Inch

Range	Graduation	Weight each	Order Code OXD-335	Price/1 TB
0 - 1"	0.001"	230g	-6010K	1266.00
1 - 2"	0.001"	300g	-6020K	1371.00
2 - 3"	0.001"	400g	-6030K	1582.00
3 - 4"	0.001"	530g	-6040K	1792.00
4 - 5"	0.001"	770g	-6050K	2002.00
5 - 6"	0.001"	800g	-6060K	2422.00

Micrometer Setting Standards

For setting external micrometers, calipers etc. to zero, providing accurate repeatability of measurements. Flat, lapped measuring ends with fitted heat insulation block. Manufactured to BS 870.

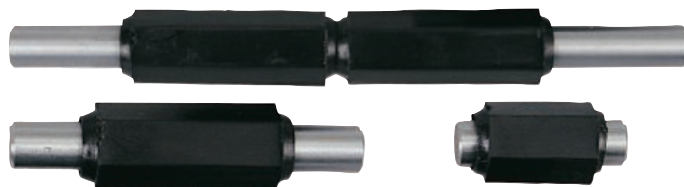

Metric

Range	Graduation	Weight each	Order Code OXD-335	Price/1 TB
0 - 25mm	0.01mm	230g	-5010K	1266.00
25 - 50mm	0.01mm	300g	-5020K	1371.00
50 - 75mm	0.01mm	400g	-5030K	1582.00
75 - 100mm	0.01mm	530g	-5040K	1792.00
100 - 125mm	0.01mm	770g	-5050K	2002.00
125 - 150mm	0.01mm	800g	-5060K	2422.00
150 - 175mm	0.01mm	-	-5070K	3683.00
175 - 200mm	0.01mm	-	-5080K	4313.00
200 - 225mm	0.01mm	-	-5090K	4733.00
225 - 250mm	0.01mm	-	-5100K	5364.00
250 - 275mm	0.01mm	-	-5110K	5469.00
275 - 300mm	0.01mm	-	-5120K	5784.00

Size	Weight each	Order Code OXD-335	Size	Weight each	Order Code OXD-335	Price/1 TB
25mm	10g	-7010K	1"	10g	-7110K	163.00
50mm	10g	-7020K	2"	10g	-7120K	163.00
75mm	20g	-7030K	3"	20g	-7130K	263.00
100mm	30g	-7040K	4"	30g	-7140K	368.00
125mm	40g	-7050K	5"	40g	-7150K	473.00
150mm	62g	-7060K	-	-	-	736.00
175mm	76g	-7065K	-	-	-	788.00
200mm	86g	-7070K	-	-	-	788.00
225mm	95g	-7075K	-	-	-	841.00
250mm	105g	-7080K	-	-	-	946.00
275mm	115g	-7085K	-	-	-	946.00
300mm	268g	-7090K	-	-	-	1156.00

KENNEDY Enamelled Frame External Micrometers
QUALITY INDUSTRIAL TOOLING

Enamelled frame and tungsten carbide tipped anvils. Manufactured to BS 870.

Accuracy:

Flatness: 0.6mm.
Parallelism: (2 + L/100) µm (fraction rounded down).
Instrumental error: ±(1 + L/75) µm (fraction rounded up).
L = maximum measuring length.

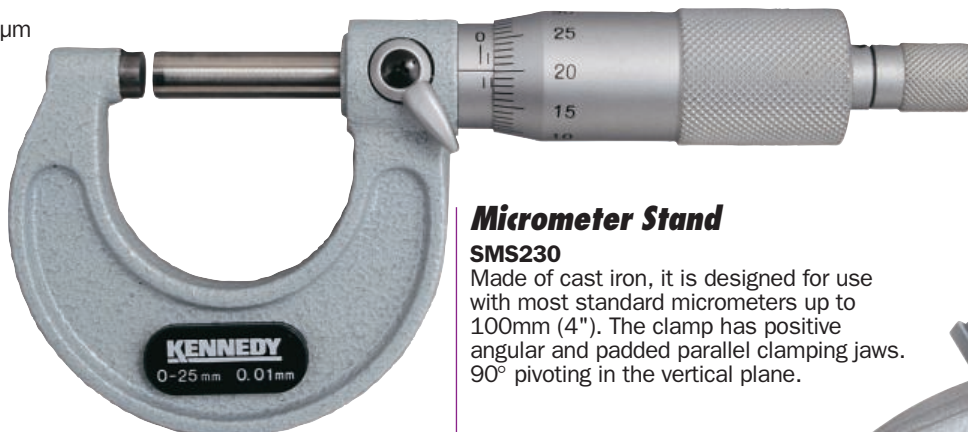

Micrometer Stand

SMS230

Made of cast iron, it is designed for use with most standard micrometers up to 100mm (4"). The clamp has positive angular and padded parallel clamping jaws. 90° pivoting in the vertical plane.



Metric

Range	Graduation	Weight each	Order Code KEN-335	Price/1 TB
0 - 25mm	0.01mm	230g	-0010K	1471.00
25 - 50mm	0.01mm	300g	-0020K	1576.00
50 - 75mm	0.01mm	400g	-0030K	1700.00
75 - 100mm	0.01mm	530g	-0040K	2312.00
100 - 125mm	0.01mm	770g	-0050K	2575.00
125 - 150mm	0.01mm	800g	-0060K	2942.00

Product Number	Weight each	Order Code KEN-335	Price/1 TB
SMS230	980g	-7230M	683.00

GROUP 335 EXTERNAL MICROMETERS

OXFORD PRECISION Precision Tool Set

Multi-purpose precision set supplied in plastic fitted bench case.

Contents:

0 - 25mm and 25 - 50mm external micrometer, 25mm setting standard, two micrometer setting spanners, 125mm/5" vernier caliper, 150mm/6" rule with pocket clip, 300mm/12" engineers rule, 100mm engineers square, pocket scriber with clip.



Description	Weight each	Order Code	Price/1 TB
10 Piece Precision Set	150g	OXD-335 -9000K	5784.00

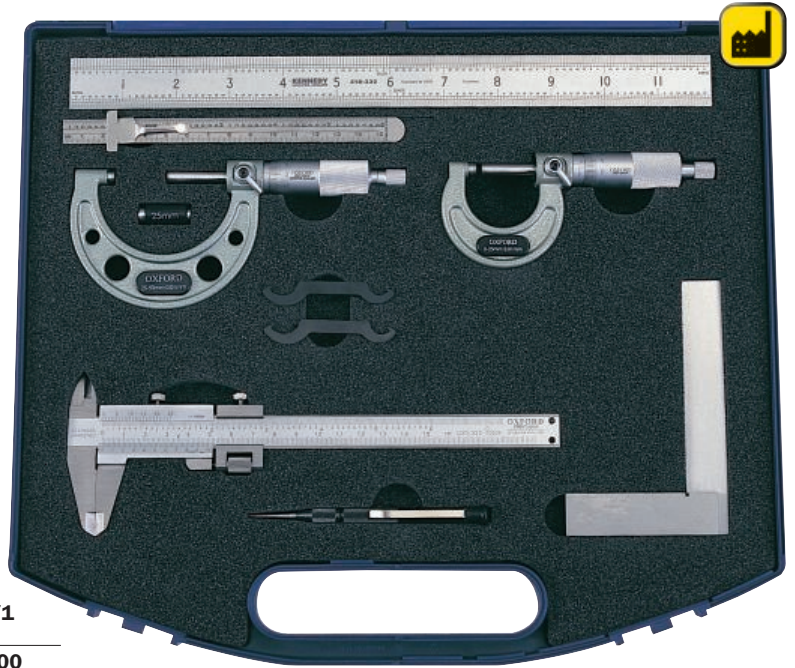

External Micrometer Sets

With enamelled frame and tungsten carbide tipped anvils and fine adjustment ratchet. Supplied in plastic fitted bench case.

-5500K

0 - 25mm, 25 - 50mm, 50 - 75mm and 75 - 100mm external micrometers, 25mm, 50mm and 75mm micrometer setting standards, two micrometer setting spanners.

-6600K

0 - 1", 1 - 2", 2 - 3" and 3 - 4" external micrometers, 1", 2" and 3" micrometer setting standards, two micrometer setting spanners.

Range	Graduation	Weight each	Order Code	Price/1 TB
0 - 100mm	0.01mm	1.90kg	-5500K	5521.00
0 - 4"	0.0001"	1.90kg	-6600K	5994.00



Apprentice Engineer's Tool Set

Contents

150mm (6") Engineer's rule, 0 - 25 and 25 - 50mm micrometers, 25mm setting standard, 10x magnification eye loupe, 150 (6") digital caliper, 0.5 - 1.0mm 20 blade feeler gauge, 51 metric 60° screw pitch gauge, pocket scriber. Technical data handbook.

Description	Weight each	Order Code	Price/1 TB
10 Pce Engineers Tool Set		OXD-335 -9200K	6835.00



PRECISION EQUIPMENT



OXFORD PRECISION *Interchangeable Anvil Micrometers*

Carbide tipped spindle faces. Hardened and ground anvils. Supplied in metal case with adjusting spanner. Four anvils and three setting standards.

Accuracy: $\pm(4+L/75)$ mm.
Measuring faces flatness: ± 0.6 mm.
Parallelism: $(2+L/100)$ mm.



Range	Graduation	Weight each	Order Code	Price/1 TB	Range	Graduation	Weight each	Order Code	Price/1 TB
0 - 100mm	0.01mm	850g	OXD-335 -3000K	4893.00	0 - 150mm	0.01mm	990g	OXD-335 -3020K	6308.00

Interchangeable Anvil Micrometers

Oxford's versatile range of micrometers with interchangeable anvils, ratchet top, lock, setting standards and wooden case. Rigid and stable cast iron frame that is perforated for lightness.

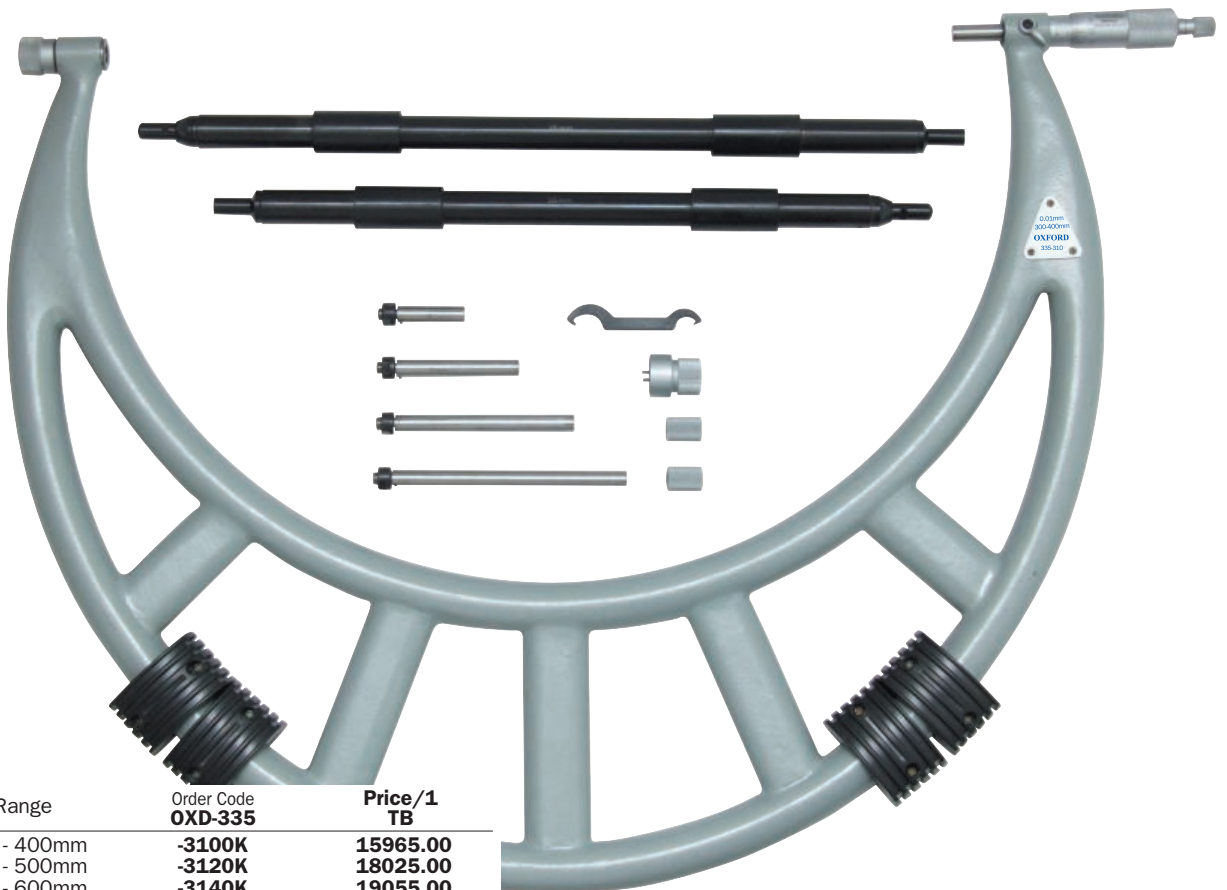

Product Number	Range	Order Code	Price/1 TB
2425-0400	300 - 400mm	-3100K	15965.00
2425-0500	400 - 500mm	-3120K	18025.00
2425-0600	500 - 600mm	-3140K	19055.00

PRODUCTS ARE ONLY AVAILABLE VIA YOUR DISTRIBUTOR

PRECISION EQUIPMENT

GROUP 335 EXTERNAL MICROMETERS

OXFORD PRECISION Mechanical Digital Micrometer - 0 - 25mm

Direct reading external micrometer for quick and easy reading. With enamelled frame and tungsten carbide precision ground micro finish measuring faces.

Measuring range: 0 - 25mm.
Graduation: 0.01mm,
0.5mm screw pitch with lock.

Supplied in a robust case with setting key, with fitted heat shield on frame.



Range	Graduation	Order Code	Price/1 TB
0 - 25mm	0.01	OXD-335	-4100K
			2054.00

Fixed Rod Depth Micrometers

Ideal for low-range measurements, this non-digital depth micrometer has a 63 or 100mm hardened tool steel base and satin chrome finish. Includes a 'constant force attachment' for use when fitting the interchangeable rods and supplied in a handy case.



Accuracy	Range	Base Size	Order Code	Price/1 TB
4 µm (microns)	0 - 25mm	63mm	OXD-335	-3310K
4 µm (microns)	0 - 25mm	100mm		-3330K
				4119.00
				4635.00

Micrometer Head

Spherical Face



Spindle diameter: 5mm.
Spindle housing diameter: 9.5mm.
Main body diameter: 14mm.
Accuracy: 0.004mm.
Range: 0 - 13mm.
Graduation: 0.01mm.



Range	Graduation	Order Code	Price/1 TB
0 - 13mm	0.01mm	OXD-335	-8200K
			1476.00

Precision Hand Tools

Manufactured from hardened steel that has been precisely ground to produce parallel edges so that the square has an exact right angle on both the inside and outside of the stock and blade, to ensure accuracy. Conforms to **BS939 Grade B**.

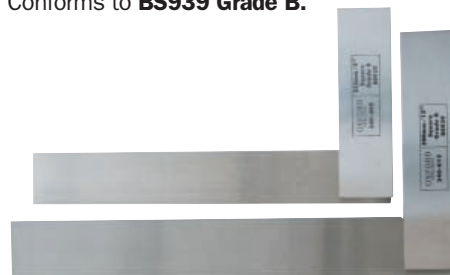

Size (mm)	Tolerance (mm)	Order Code	Price/1 TB
75 (3")	+/- 0.016	OXD-340	-0030K
100 (4")		-0040K	1191.00
150 (6")		-0060K	1500.00
225 (9")		-0090K	1575.00
300 (12")		-0120K	3605.00
	+/- 0.024		-0120K
			4635.00

30° Anvil Micrometers

Used for measuring within small grooves or recesses and for quick comparisons of thread accuracy in screw cutting operations. With knurled thimble, ratchet stop and thumb lock. Enamelled frame with satin chromed finish barrel and sleeve.



Range	Graduation	Weight each	Order Code	Price/1 TB
0 - 25mm	0.01mm	250g	OXD-335	-3520K
				2318.00

Wire Micrometer

Specially designed for measuring wire diameters 0 - 10mm. The front of the body is flat to help support the wire when measuring. With knurled thimble, ratchet stop and vernier scale barrel, all over satin chrome finish.



Capacity	Graduation	Weight each	Order Code	Price/1 TB
0 - 10mm	0.002mm	150g	OXD-335	-2000K
				2318.00

PRECISION EQUIPMENT

KENNEDY QUALITY INDUSTRIAL TOOLING Screw Plug Gauges

Double-Ended Go & No Go

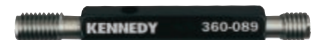

Thread Size	Weight each	Order Code	Price/1 TB
Metric Coarse - Class 6H Tolerance			
M2.0 x 0.40	4g	-0810K	7725.00
M2.5 x 0.45	4g	-0830K	8755.00
M3.0 x 0.50	4g	-0840K	4893.00
M4.0 x 0.70	10g	-0860K	5253.00
M5.0 x 0.80	12g	-0880K	5253.00
M6.0 x 1.00	14g	-0890K	5253.00
M7.0 x 1.00	26g	-0900K	5253.00
M8.0 x 1.25	28g	-0910K	5253.00
M9.0 x 1.25	28g	-0920K	5253.00
M10.0 x 1.50	52g	-0930K	5253.00
M12.0 x 1.75	70g	-0950K	6094.00
M14.0 x 2.00	108g	-0960K	8405.00
M16.0 x 2.00	128g	-0970K	8668.00
M18.0 x 2.50	132g	-0980K	9088.00
M20.0 x 2.50	148g	-0990K	9456.00
M24.0 x 3.00	272g	-1010K	11347.00
M30.0 x 3.50	484g	-1030K	14709.00
M36.0 x 4.00	622g	-1050K	14972.00



Portable Optical Refractometer



For determining the concentration of oil in water emulsions and transparent solutions, such as machine shop coolant. Maintaining the correct mixture in coolant systems is vital to ensure optimum performance from cutting tools. To protect the machine and workpiece from corrosion and to reduce the risk of health hazards arising from incorrect concentrations of water soluble oils. To economise the use of water base cutting fluids and grinding fluids.



Lens for Portable Refractometer

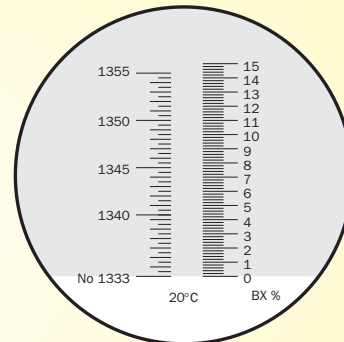

Calibrated Refractive Scale

Specifications:

Range ND: 1.333 - 1.356. Bx: 0 - 15%.

Eye-piece magnification: 11x.

Telescopic lens magnification: 4x.

Accuracy: ±0.0003 ±0.2%

Lattice value: 0.0005 0.2%

Supplied in a plastic case complete with calibration screwdriver and operator manual.

Refractometer

Dimensions	Weight each	Order Code	Price/1 TB
38 x 38 x 185mm	30g	OXD-336 -1010K	6695.00

Spares

Description	Weight each	Order Code	Price/1 TB
Lens for Portable Refractometer	10g	OXD-398 -3630K	582.00

KENNEDY Steel Gauge Block Sets

Supplied in high quality wooden bench cases, complete with certificate of calibration. Available in two grades. Manufactured to **BS EN ISO 3650**. Complete with **UKAS** Certificate of Calibration.



Grade 2: For Workshop Use

Number of Pieces	Range (inclusive)	Increments	Weight each	Order Code KEN-338	Price/1 TB
36 Piece Inch					
(2)	.05"-.10"	.05"	2.4kg	-3360K	9785.00
(9)	.1001-.1009"	.0001"			
(9)	.101-.109"	.001"			
(9)	.110-.190"	.010"			
(4)	.2-.5"	.10"			
(3)	1, 2 & 4"				
81 Piece Inch					
(9)	.1001-.1009"	.0001"	4.0kg	-3810K	12875.00
(49)	.101-.149"	.001"			
(19)	.05-.95"	.05"			
(4)	1-4"	1"			
47 Piece Metric					
(1)	1.005mm		2.1kg	-4470K	12875.00
(9)	1.01-1.09mm	.01mm			
(9)	1.1-1.9mm	.1mm			
(24)	1-24mm	1mm			
(4)	25-100mm	25mm			
88 Piece Metric					
(1)	1.0005mm		2.8kg	-4880K	15965.00
(9)	1.001-1.009mm	.001mm			
(49)	1.01-1.49mm	.01mm			
(20)	.5-10mm	.5mm			
(9)	20-100mm	10mm			

Grade 1: For Inspection Use

Number of Pieces	Range (inclusive)	Increments	Weight each	Order Code KEN-339	Price/1 TB
81 Piece Inch					
(9)	.1001-.1009"	.0001"	4.0kg	-4810K	31991.00
(49)	.101-.149"	.001"			
(19)	.05-.95"	.05"			
(4)	1-4"	1"			
47 Piece Metric					
(1)	1.005mm		2.4kg	-5470K	22273.00
(9)	1.01-1.09mm	.01mm			
(9)	1.1-1.9mm	.10mm			
(24)	1-24mm	1mm			
(4)	25-100mm	25mm			
88 Piece Metric					
(1)	1.0005		2.8kg	-5880K	32412.00
(9)	1.001-1.009mm	.001mm			
(49)	1.01-1.49mm	.01mm			
(20)	.5-10mm	.5mm			
(9)	20-100mm	10mm			



PRECISION EQUIPMENT

Matched and numbered pairs of closed grained iron castings accurately machined. Precision 90° vee blocks. Supplied as a pair.

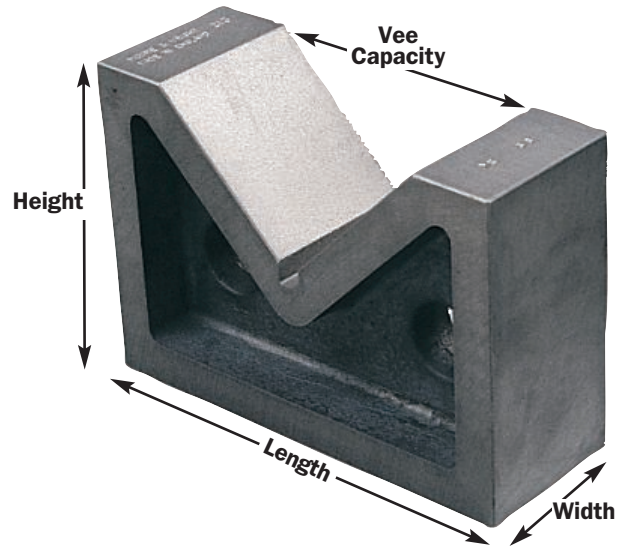
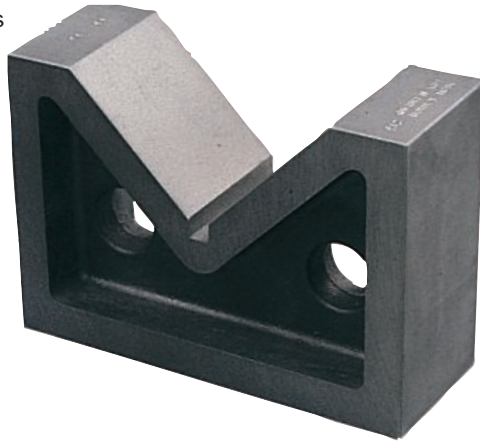

Dimensions L x W x H	Vee Capacity	Weight/ Pair	Order Code OXD-370	Price/Pr TB
75 x 33 x 60mm	45	1.7kg	-2110K	7285.00
100 x 40 x 65mm	56	2.9kg	-2120K	8604.00
125 x 50 x 78mm	62	4.8kg	-2130K	9498.00
150 x 62 x 88mm	78	6.5kg	-2140K	9986.00
200 x 100x 140mm	113	11.2kg	-2150K	11037.00
250 x 125 x 165mm	125	19.0kg	-2160K	16995.00

Workshop Vee Blocks & Clamp

Designed for checking precision machine parts. Hardened and precision ground steel supplied in matched pairs, each with V-grooves central and parallel to the sides and base ensuring perfect alignment. Complete set with two V-blocks (one pair) and two clamps.



Dimensions Length x Width x Height	Weight/ Pair	Order Code OXD-370	Price/Pr TB
50 x 37 x 37mm	1.0kg	-2300K	5584.00

Workshop Grade Hollow Ground Vee Blocks & Clamp

Designed for checking precision machine parts. Hardened and precision ground steel supplied in matched pairs, each with V-grooves central and parallel to the sides and base ensuring perfect alignment. Complete set with two V-blocks (one pair) and two clamps. Supplied with malleable iron clamps with steel screws.

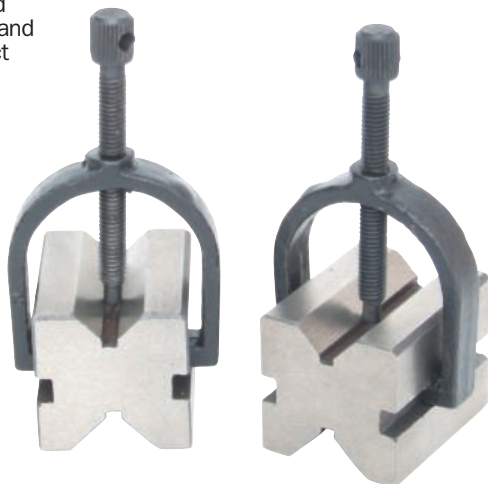

Dimensions Length x Width x Height	Weight/ Pair	Order Code OXD-370	Price/Pr TB
31.5 x 40 x 31.5mm	1.7kg	-2310K	6835.00

Angle Plates

Open End

Open end angle plates are versatile accessories which can be used to clamp and hold work in a vertical position for planing, milling, or drilling. Work can be clamped and rotated through several planes for measurement or machining without repositioning. The slots allow work to be easily fastened to the plate, and the plate to a fixture base or machine bed. Manufactured from close grained cast iron. **BS : 5535 Grade B.**



Dimensions Length x Width x Height	Weight each	Order Code OXD-370	Price/1 TB
12½" x 10" x 8"	27kg	-1370K	21595.00

Webbed End

Webbed slotted angle plates can be used for rapid mounting fixtures for machine set-up, layout, or inspection. They are heavily ribbed for strength and rigidity. Sides and ends are machine finished. Manufactured from close grained cast iron. **BS : 5535 Grade B.**



Dimensions Length x Width x Height	Weight each	Order Code OXD-370	Price/1 TB
3½" x 3" x 2½"	1.4kg	-1100K	3315.00
12½" x 10" x 8"	26.5kg	-1170K	18601.00



OXFORD *Steel Parallels*
PRECISION

Hardened and ground steel parallels for workshop use. Supplied in pairs for packing or levelling components prior to machining in tool rooms or machine shops.

Supplied in Pairs

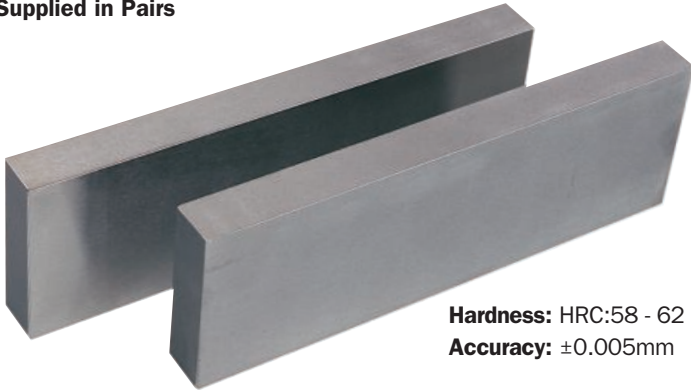

Hardness: HRC:58 - 62
Accuracy: ±0.005mm

Dimensions Length x Width x Height	Order Code OXD-372	Price/Pair TB
8 x 15 x 100mm	-4080K	1133.00
10 x 4 x 160mm	-3700K	567.00
10 x 20 x 100mm	-4100K	1339.00
12 x 20 x 100mm	-4120K	2059.00
14 x 10 x 150mm	-3800K	716.00
14 x 4 x 160mm	-3710K	670.00
16 x 10 x 150mm	-3810K	768.00
16 x 25 x 150mm	-4160K	2266.00
18 x 4 x 160mm	-3720K	773.00
18 x 10 x 150mm	-3820K	788.00
20 x 10 x 150mm	-3830K	912.00
20 x 30 x 200mm	-4200L	2575.00
22 x 4 x 160mm	-3730K	861.00
22 x 10 x 150mm	-3840K	979.00
24 x 10 x 150mm	-3850K	1041.00
25 x 40 x 250mm	-4250K	4223.00
26 x 4 x 160mm	-3740K	922.00
26 x 10 x 150mm	-3860K	1082.00
28 x 10 x 150mm	-3870K	1046.00
30 x 4 x 160mm	-3750K	927.00
30 x 10 x 150mm	-3880K	1133.00
32 x 10 x 150mm	-3890K	1161.00
34 x 4 x 160mm	-3760K	1082.00
35 x 10 x 150mm	-3900K	1161.00
38 x 4 x 160mm	-3770K	1133.00
40 x 10 x 150mm	-3910K	1442.00
42 x 4 x 160mm	-3780K	1236.00
45 x 10 x 150mm	-3920K	1545.00
50 x 10 x 150mm	-3930K	1648.00

18 Piece Set

Contents: nine pairs of the following sizes:

- 10 x 4 x 160mm,
- 14 x 4 x 160mm,
- 18 x 4 x 160mm,
- 22 x 4 x 160mm,
- 26 x 4 x 160mm,
- 30 x 4 x 160mm,
- 34 x 4 x 160mm,
- 38 x 4 x 160mm,
- 42 x 4 x 160mm.

Supplied in wooden storage box.



18
PIECES

Description	Weight each	Order Code OXD-372	Price/1 TB
18 Piece Set	2.8kg	-3620K	8755.00

16 Piece Set

Contents: eight pairs of the following sizes:

- 5 x 16 x 100mm,
 - 6 x 18 x 100mm,
 - 8 x 24 x 100mm,
 - 10 x 30 x 100mm,
 - 12 x 36 x 150mm,
 - 14 x 48 x 150mm,
 - 18 x 60 x 150mm,
 - 22 x 62 x 150mm.
- And support blocks.



16
PIECES

Description	Weight each	Order Code OXD-372	Price/1 TB
16 Piece Set	12.7kg	-3600K	10299.00

28 Piece Set

Contents: fourteen pairs of the following sizes:

- 14 x 10 x 150mm,
- 16 x 10 x 150mm,
- 18 x 10 x 150mm,
- 20 x 10 x 150mm,
- 22 x 10 x 150mm,
- 24 x 10 x 150mm,
- 26 x 10 x 150mm,
- 28 x 10 x 150mm,
- 30 x 10 x 150mm,
- 32 x 10 x 150mm,
- 35 x 10 x 150mm,
- 40 x 10 x 150mm,
- 45 x 10 x 150mm,
- 50 x 10 x 150mm.

Supplied in wooden storage box.



28
PIECES

Description	Weight each	Order Code OXD-372	Price/1 TB
28 Piece Set	11.5kg	-3640K	13905.00

PRECISION EQUIPMENT



GROUP 404 **BIN STORAGE SYSTEMS**

Page **276 - 277**

GROUP 405 **RACKING**

Page **278**

GROUP 405 **WORKBENCHES & CABINETS**

Page **279 - 280**

GROUP 413 **GROUND FLAT STOCK**

Page **281**

GROUP 415 **SHIMS**

Page **281**

GROUP 421 **KEY STEEL**

Page **281**

GROUP 425 **CLAMPING FIXTURES**

Page **282 - 294**

GROUP 437 **INDEXING UNITS**

Page **295**

GROUP 437 **ROTARY TABLES**

Page **295**

GROUP 440 **CHUCKS**

Page **296**

GROUP 442 **CHUCK ARBORS**

Page **297**

GROUP 443 **TOGGLE CLAMPS**

Page **298 - 305**

GROUP 445 **BENCH VICES**

Page **310**

GROUP 445 **MACHINE VICES**

Page **306 - 307**

GROUP 445 **TOOLPOSTS**

Page **308 - 309**

GROUP 445 **GRINDING CARRIERS**

Page **309**

GROUP 447 **COOLANT HOSE**

Page **311**

GROUP 448 **BENCH SHEARS**

Page **314**

GROUP 450 **KNURLING TOOLS**

Page **314**

GROUP 460 **DIE SPRINGS**

Page **312**

GROUP 475 **LATHE CHUCKS**

Page **315**

GROUP 482 **MORSE TAPER SLEEVES**

Page **316**

GROUP 488 **REVOLVING & SOLID CENTRES**

Page **317**

GROUP 490 **LATHE CHUCK JAWS**

Page **318**

GROUP 495 **WHEEL DRESSERS**

Page **319**



WORKSHOP EQUIPMENT

**Product Groups
400 - 495**

Product Grading



Production

High performance industrial tooling designed for continuous use applications on machine tools where repeatability and long tool life are of critical importance.



Professional

Industrial tooling that has enhanced features and benefits demanded by craftsmen and professional users.



Industrial

Designed for regular use in industrial applications. Manufactured to stringent quality levels and international standards.



Workshop

Standard quality tooling for use by tradesmen and generally industrial use.



Maintenance

Products designed for general maintenance of machines, workshops, garages and some household applications.



Home Improver

DIY quality tooling. Designed for home use and light industrial applications.

Contents

Description	Group	Page
Bench Shears	448	314
Bin Storage Systems	404	276 - 277
Chuck Arbors	442	297
Keys	441	297
Chucks	440	296
Clamping Fixtures	425	282 - 294
Coolant Hose	447	311
Die Springs	460	312
Grinding Carriers	445	309
Ground Flat Stock	413	281
Indexing Units	437	295
Key Steel	421	281
Lathe Chucks	475	315
Chuck Jaws	490	315
Morse Taper Sleeves	482	316
Racking	405	278
Revolving & Solid Centres	488	317
Rotary Tables	437	295
Shims	415	281
Toggle Clamps	443	298 - 305
Toolposts	445	308 - 309
Turning & Knurling Tools	450	314
Vices	445	306 - 310
Wheel Dressers	495	319
Woodworking Benches	405	279
Work Benches & Cabinets	405	279 - 280

GROUP 404 BIN STORAGE SYSTEMS

WORKSHOP EQUIPMENT

MATLOCK Plastic Storage Bins

Manufactured from high strength polypropylene. Fit on standard louvre panel, interlocking design. Supplied with risers and label holders.

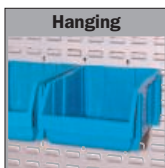

Size	Dimensions L x W x H (mm)	Order Code MTL-404				Box Qty	Price/1 TB
		Blue	Green	Red	Yellow		
No.0	130 x 85 x 53	-1000B	-1000G	-1000R	-1000Y	300	91.00
No.1	163 x 104 x 80	-1010B	-1010G	-1010R	-1010Y	100	139.00
No.2	237 x 157 x 132	-1020B	-1020G	-1020R	-1020Y	64	268.00
No.3	278 x 222 x 165	-1030B	-1030G	-1030R	-1030Y	24	335.00
No.3A	350 x 280 x 184	-1035B	-1035G	-1035R	-1035Y	8	592.00
No.4	425 x 280 x 184	-1040B	-1040G	-1040R	-1040Y	12	892.00
No.5	425 x 280 x 260	-1050B	-1050G	-1050R	-1050Y	8	1226.00

Storage Bin Accessories

For Matlock storage bins.

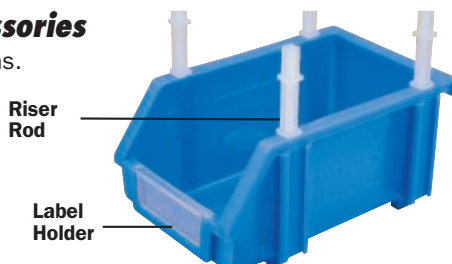

Description	Order Code MTL-404	Price/1 TB
Set of 4 Riser Rods	-9010K	54.00
Single Riser rod for No.3A, 4 & 5 Bins	-9020K	36.00
Label Holder For No.0 Bins	-3500K	36.00
Label Holder For No.1 Bins	-3510K	36.00
Label Holder For No.2 Bins	-3520K	36.00
Label Holder For No.3 & 4 Bins	-3530K	36.00
Label Holder For No.3A & 5 Bins	-3540K	36.00

Heavy Duty Plastic Storage Bins

Ergonomic packing - storing one container inside another exceptionally improves the logistics of packing. Slat attachments - can be attached with screws to a wall. Module - special clasps make it possible to create a wall of module boxes. Space for a label.



NEW



Dimensions W x L x H (mm)	Order Code MTL-404 Blue	Order Code MTL-404 Green	Order Code MTL-404 Yellow	Order Code MTL-404 Red	Price/1 TB
116 x 112 x 75	-2130K	-2140K	-2160K	-2150K	57.00
116 x 161 x 75	-2170K	-2180K	-2200K	-2190K	78.00
116 x 212 x 75	-2210K	-2220K	-2240K	-2230K	114.00
170 x 240 x 126	-2250K	-2260K	-2280K	-2270K	181.00
204 x 340 x 155	-2290K	-2300K	-2320K	-2310K	371.00
330 x 500 x 187	-2330K	-2340K	-2360K	-2350K	690.00

Heavy Duty Bin/Rack Sets

Each set comes with a fixing wall, a useful, wide plate which attaches to the wall with screws and can fit several containers of different sizes. Mounting of the boxes is based on an overlap system. It enables firm and stable fastening to the fixing wall, and quick removal when needed.

10 Piece Set

Contains 1 fixing wall, 3 blue bins, 3 black bins and 3 red bins.

20 Piece Set

Contains 2 fixing walls, 6 blue bins, 6 black bins and 6 red bins.



**10
PIECES**

**20
PIECES**



Item	Overall Size (mm)	Order Code MTL-404	Price/1 TB
10 Piece Set	345 x 385 x 90	-2110K	567.00
20 Piece Set	345 x 385 x 160	-2120K	1339.00

SENATOR Plastic Storage Bins

High strength polypropylene storage bins with label holders, designed for component or part storage. Bins can stand alone, be nested on top of each other or hung on louvred panels, allowing you to create the storage system to satisfy your specific requirements. Available in three sizes and four different colours blue, green, yellow and red.



Product Number	Size (L x W x H) (mm)	Pack Qty	Order Code SEN-404				Price/1 TB
			Blue	Green	Yellow	Red	
Sen1	165 x 110 x 75	35	-1010B	-1010G	-1010Y	-1010R	57.00
Sen2	240 x 155 x 125	35	-1020B	-1020G	-1020Y	-1020R	140.00
Sen3A	350 x 220 x 165	10	-1040B	-1040G	-1040Y	-1040R	279.00

AVON Cardboard Storage Bins

For easy identification and storage of parts and other components on shelves. Manufactured from corrugated card with writable panels. Supplied flat in packs of 50.

Contents not included



**PACK OF
50**

Size L x W x H (mm)	Pack Qty	Order Code AVN-404	Price/1 TB
152 x 76 x 115 (6" x 3" x 4.5")	50	-2010A	876.00
228 x 100 x 115 (9" x 4" x 4.5")		-2011B	1236.00
228 x 152 x 115 (9" x 6" x 4.5")		-2012C	1339.00
228 x 204 x 115 (9" x 8" x 4.5")		-2013D	1545.00
304 x 100 x 115 (12" x 4" x 4.5")		-2014E	1339.00

MATLOCK

Mobile Trolleys/Racks

Similar to a free standing rack but mobile. Fitted with four 5" castors to the base which supports double sided louvre panels. Available in one height and two widths.

Colour: dark grey/light grey.



Free Standing Racks

Available in two heights and two widths. Made from 16swg channel section which supports louvre panels either single or double sided.

Colour: dark grey/light grey.



WORKSHOP EQUIPMENT



Storage Bins Not Included

Size (H x W)	Order Code MTL-405	Price/1 TB
Double Sided Free Standing Louvre Rack		
924 x 457	-7610K	12875.00
924 x 871	-7615K	19055.00
1838 x 457	-7620K	18540.00
1838 x 871	-7625K	27295.00
Single Sided Free Standing Louvre Rack		
924 x 457	-7650K	9785.00
924 x 871	-7655K	11845.00
1838 x 457	-7660K	13905.00
1838 x 871	-7665K	18025.00

Storage Bins Not Included

Description	Size (H x W)	Order Code MTL-405	Price/1 TB
Mobile Louvre Rack	1080 x 457	-7410K	18025.00
	1080 x 877	-7420K	24205.00

Steel Louvred Panels

Pressed steel panels with high frequency louvres that will accept most makes of plastic storage bin. High frequency louvres allow bins to be hung in a high-density configuration in any mix of sizes/colours.

The lip on the rear of the plastic storage bin sits securely over the louvre of the panel. The modular design allows storage bins to be easily removed and replaced when required.

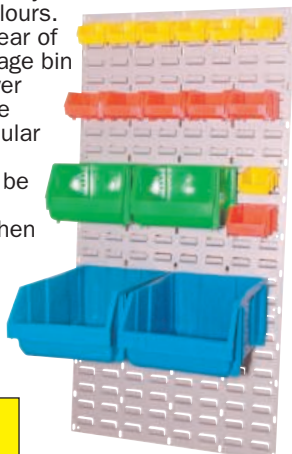

Storage Bins Not Included

Type	Width x Height (mm)	Order Code MTL-404	Price/1 TB
LP450	450 x 450	-2004P	1344.00
LP900	450 x 900	-2009P	1956.00
LP1600	450 x 1600	-2016P	3605.00
LP1800	450 x 1800	-2018P	4184.00

Bench Assembly Units

A free standing unit supporting a louvre Panel for use on benches or tables. Available in one height and two widths. Kit comprises: louvre panel, support rods and fixings.

Colour: light grey.



Storage Bins Not Included

Description	Size (H x W)	Order Code MTL-405	Price/1 TB
Bench Louvre Rack	457 x 436	-7250K	2059.00
	457 x 852	-7260K	3605.00

Euro Containers

Practical Euro boxes, ideal for use wherever hygienic stackable plastic containers play an important role in transport and storage. Resistant to acids and alkaline solutions, cold and heat. Optimal handling due to ergonomic handles. Suitable for conveyor systems.

Available in five sizes:

- 400 x 300 x 170mm,
- 400 x 300 x 220mm,
- 600 x 400 x 170mm,
- 600 x 400 x 220mm,
- 600 x 400 x 320mm.

Lids supplied separately



NEW

Size (L x W x H)	Order Code MTL-404	Price/1 TB
400 x 300 x 170	-4210K	299.00
400 x 300 x 220	-4212K	399.00
600 x 400 x 170	-4234K	499.00
600 x 400 x 220	-4236K	599.00
600 x 400 x 320	-4240K	699.00

Lids to suit foldable boxes and euro containers

Size (L x W)	Order Code MTL-404	Price/1 TB
400 x 300mm	-4400K	155.00
600 x 400mm	-4402K	226.00

Euro Foldable Boxes

Foldable storage boxes made from tough grey polypropylene. Compatible in size with the Euro containers (use the same lids) and can be stacked with or without lids. Simple to collapse for space saving storage when not in use.

NEW

Lid supplied separately see above right



Size (H x W x D)	Order Code MTL-404	Price/1 TB
600 x 400 x 320mm	-4330K	1350.00

Euro Nesting Bins with Integral Lids

High strength polypropylene Euro boxes with reinforced corners and rims and integral interlocking hinged lids. Smooth flat base allows silent movement on conveyors making them suitable for use in distribution centres or warehouse storage. All containers feature ergonomic hand grips and can be sealed using security tags.

Available in 20, 40 or 54ltr capacities.



Capacity	Size (L x W x H)	Order Code MTL-404	Price/1 TB
Colour: Blue			
20ltr	400 x 300 x 260mm	-2500K	1014.00
40ltr	600 x 400 x 250mm	-2520K	1332.00
54ltr	600 x 400 x 335mm	-2530K	1597.00
Colour: Grey			
20ltr	400 x 300 x 260mm	-2600K	1014.00
40ltr	600 x 400 x 250mm	-2620K	1332.00
54ltr	600 x 400 x 335mm	-2630K	1597.00

GROUP 405 RACKING

MATLOCK

Standard Duty Racking

5 Shelves

This racking system has uprights and beams made of medium gauge steel with a corrosion resistant powder coating and rubber feet to protect the floor. It is easy to assemble, interlocking with no nuts and bolts to worry about. The shelves are easily adjustable and can take up to 150kg UDL (uniformly distributed load) with the rack being fixed to a wall. Supplied with wooden shelves.



Shelf Capacity 100kg Uniformly Distributed Load

SELF ASSEMBLY Tools Required

Dimensions (W x D x H) mm	Max. Shelf Capacity	Number of Shelves	Order Code MTL-405	Price/1 TB
1010 x 400 x 1830	150kg	5	-1760K	4635.00
Shelf to suit MTL-405-1760K			-8670K	567.00

Heavy Duty Racking

5 Shelves

This racking system has two ways of assembly with uprights and beams made of heavy gauge steel with a corrosion resistant powder coating and rubber feet to protect the floor. It is easy to assemble, interlocking 'keyhole' slots, no nuts and bolts. The shelves are easily adjustable and can take up to 318kg UDL (uniformly distributed load) with the rack being fixed to a wall. Supplied with wooden shelves.

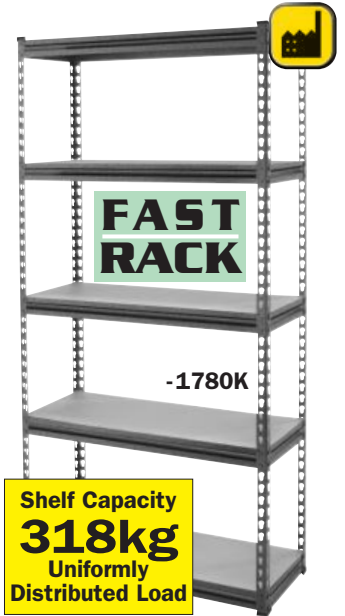

Shelf Capacity 318kg Uniformly Distributed Load

SELF ASSEMBLY Tools Required

Assembly options



Dimensions (W x D x H) mm	Max. Shelf Capacity	Number of Shelves	Order Code MTL-405	Price/1 TB
915 x 460 x 1830	318kg	5	-1740K	5305.00
1230 x 610 x 1830	318kg	5	-1780K	8194.00
Shelf to suit MTL-405-1740K			-8640K	773.00
Shelf to suit MTL-405-1780K			-8700K	1029.00

Heavy Duty Racking

4 Shelves

This racking system can be assembled in five ways and has uprights and beams made of heavy gauge steel with a corrosion resistant powder coating and rubber feet to protect the floor. It is easy to assemble, interlocking with just two nuts and bolts joining one upright frame to the next. The 430mm deep shelves are easily adjustable and can take up to 455kg UDL (uniformly distributed load) with the rack being fixed to a wall.



Shelf Capacity 455kg Uniformly Distributed Load

SELF ASSEMBLY Tools Required

Dimensions (W x D x H) mm	Max. Shelf Capacity	Number of Shelves	Order Code MTL-405	Price/1 TB
1040 x 430 x 1830	455kg	4	-1660K	10254.00
Shelf to suit MTL-405-1660K			-8610K	979.00

Assembly options

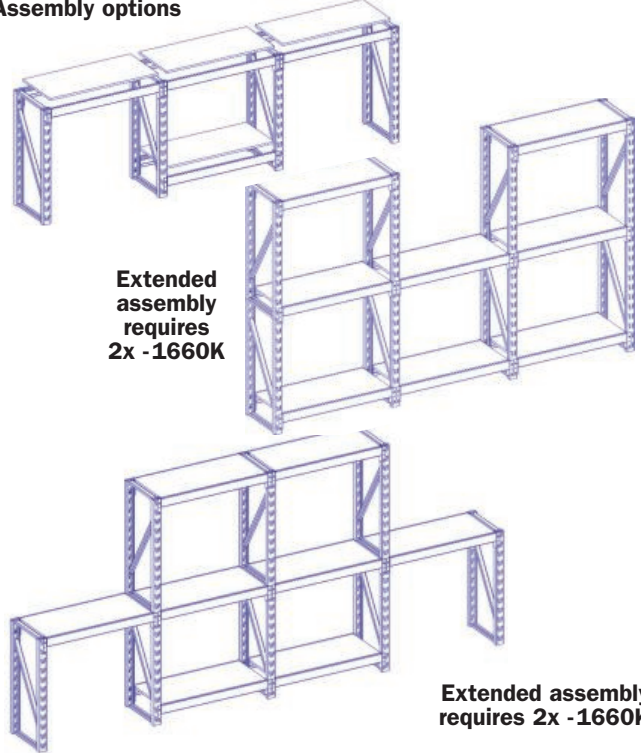

Extended assembly requires 2x -1660K

Extended assembly requires 2x -1660K

Twin-Lock Shelving

Twin-Lock shelving provides an excellent adjustable storage system that is both robust and versatile. Offering a range of 'Spur compatible' components including uprights, brackets and bookends. Easy hang, double-sided system with hygienic Protecta-cote antimicrobial powder coating.

NEW

Available in six lengths 710mm to 2400mm

Size (mm)	Type	Order Code MTL-405	Price/1 TB
200	Left Hand Shelf End	-1800K	232.00
200	Right Hand Shelf End	-1810K	232.00
150	Flexible Bookends (Pairs)	-1820K	232.00
200		-1830K	289.00
250		-1840K	361.00
710		-1850K	309.00
1000	Uprights (Singles)	-1860K	361.00
1220		-1870K	464.00
1600		-1880K	567.00
1980		-1890K	670.00
2400		-1900K	876.00
120		-1910K	114.00
170	Shelf Bracket (Singles)	-1920K	129.00
270		-1930K	181.00
370		-1940K	237.00
320		-1950K	201.00

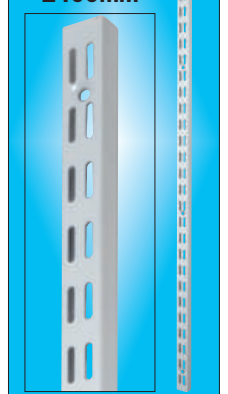
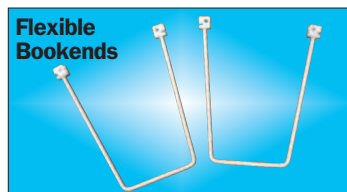

KENNEDY *Portable Bench & Vice*
QUALITY INDUSTRIAL TOOLING

Rapid clamping. Full graduated working surface with channelled chuck block guides. Includes four adjustable chuck blocks and 4 profile blocks. Aluminium mitre guides and lower support arm to assist power tool use. Rapid fold/unfold with quick lock and release action, compact and easy to store.

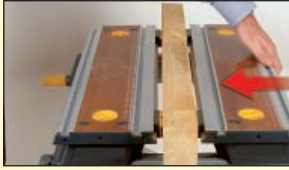

Rapid clamping



Rapid fold/unfold with auto lock



Lower support arm



Aluminium mitre guide



Mitre clamping

Spare Parts

Description	Order Code	Price/1 TB
4 in 1 portable workbench	-4600K	6179.00

Description	Order Code	Price/1 TB
Spare clamping block	-4610K	258.00
Replacement Rubber Feet (Pk 4)	-4620K	284.00

Portable Bench Top Workstation

Includes two trays to store tools & small parts. Full graduated working surface with channelled chuck block guides. Includes four adjustable chuck blocks and profile adaptor blocks. Mounting holes in the feet of the workstation allow it to be fitted to a workbench if required. Compact, portable with carry handle and easy to store.

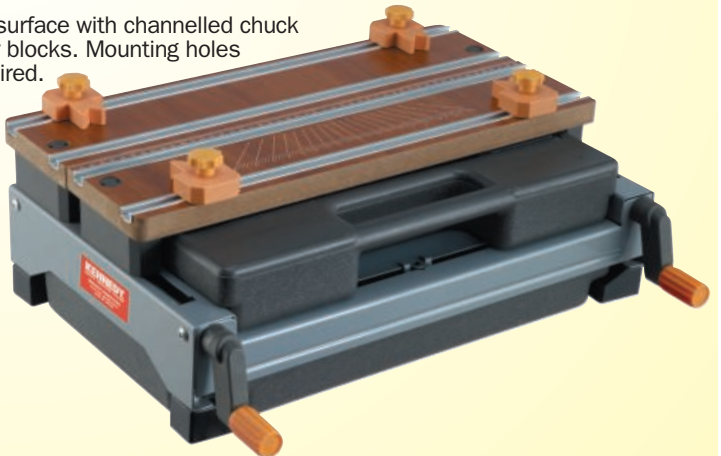

Storage trays



Mitre clamping



Compact, portable and easy to store



Fully graduated working surface

Description	Order Code	Price/1 TB
4 in 1 Portable Workbench	-4700K	3039.00
Spare Parts		
Spare Clamping Block	-4610K	258.00
Spare Clamping Handle with Sleeve	-4720K	232.00

SENATOR *Home Improver Workbench & Vice*
QUALITY TOOLING

Medium duty for hobby and DIY use. All steel body. Durable worktop with metric/inch gauging scale and protractor markings. Easy to assemble. Sturdy splay legs with non-slip rubber feet. Four quick-change worktop functions. Supplied with four chuck blocks, assembly spanners and instructions.

- Worktop width:** 600mm.
- Worktop depth (individual):** 115mm.
- Worktop depth (combined):** 230mm.
- Overall height:** 800mm.
- Width (when collapsed for storage):** 280mm.
- Maximum opening capacity:** 140mm.
- Maximum clamping capacity (with blocks):** 285mm.
- Weight capacity:** 200kg/440lbs.



Transforms to an upright vice with jaws set at 90°



Transforms to a versatile saw-horse with jaws set at 45°



Transforms to a T-vice



Ideal for clamping pipe and other convex workpieces



Solid hardwood worktop with protractor and rule markings.

Height (mm)	Width (mm)	Order Code	Price/1 TB
800	600	-9650K	2632.00

GROUP 405/420

WORKBENCHES & CABINETS/RACK CLAMPS

SENATOR
QUALITY TOOLING

Cabinet with Shelf & Workbench

Manufactured from cold rolled steel plate with a hard wearing corrosion resistant powder coated finish. Hard wearing solid wooden work surface. Two shelves. Adjustable feet. Supplied with assembly instructions.

Maximum shelf capacity: 20kg.
Maximum cabinet capacity: 150kg.



SELF ASSEMBLY
Tools Required

Weight	Order Code	Price/1 TB
25.5kg	SEN-405 -5030K	9785.00

Locking Cabinet & Workbench

Lockable storage cabinet with two shelves.

Overall dimensions (W x D x H): 838 x 508 x 852mm.
Max shelf capacity: 20kg.
Max cabinet capacity: 150kg.



SELF ASSEMBLY
Tools Required

Weight	Order Code	Price/1 TB
27.0kg	SEN-405 -5020K	8755.00

5 Drawer Cabinet & Workbench

The five drawers have a smooth action sliding mechanism.



SELF ASSEMBLY
Tools Required

Weight	Order Code	Price/1 TB
43.0kg	SEN-405 -5010K	13905.00

Locking Cabinet with Shelf & Workbench

Lockable storage cabinet with two shelves and two open shelves for additional storage.

Overall dimensions (W x D x H): 1372 x 508 x 865mm.
Max shelf/drawer capacity: 25kg.
Max cabinet capacity: 180kg.



Shelf Capacity
25kg
Uniformly Distributed Load

SELF ASSEMBLY
Tools Required

Dimensions W x D x H (mm)	Weight	Order Code	Price/1 TB
1372 x 508 x 865	48.5kg	SEN-405 -5040K	15450.00

5 Drawer Cabinet & Shelved Workbench

The five drawers have a smooth action sliding mechanism. Two open shelves for additional storage.

Overall dimensions (W x D x H): 1372 x 508 x 865mm.
Max shelf drawer capacity: 25kg.
Max cabinet capacity: 180kg.



Shelf Capacity
25kg
Uniformly Distributed Load

SELF ASSEMBLY
Tools Required

Dimensions W x D x H (mm)	Weight	Order Code	Price/1 TB
1372 x 508 x 865	61.0kg	SEN-405 -5050K	22145.00

KENNEDY QUALITY INDUSTRIAL TOOLING
2 Drawer Workbench

Professional quality two drawer workbench constructed from heavy gauge steel for sturdy long-term use. Ideal for a range of workshop and industrial applications. Drawers are lockable and fitted with smooth glide drawer runners. Full length storage shelf. Quick and easy assembly. Powder coated finish.

Dimensions (W x D x H): 1500 x 640 x 865mm.



Shelf Capacity
40kg
Uniformly Distributed Load

Dimensions (W x D x H)	Weight	Order Code	Price/1 TB
1500 x 640 x 865	77.4kg	KEN-405 -2320K	22403.00

SELF ASSEMBLY
Tools Required

INDEXA Standard Duty Rack Clamps

For various engineering and maintenance applications across all industrial sectors. A bright yellow epoxy coating gives the sliding jaw and J bar added protection, preventing significant deterioration and prolonging the working life of the working parts.

Features: Spring loaded jaw that stays in position when pressure removed. Jaw moves to securely clamp angled surfaces. No long screws to bend. Tightening the clamps does not impose rotation to the workpiece.

Applications: Metal fabrication. Welding. Machining. Site maintenance. Moulding box and die holding. Toolroom. Plastic and fibreglass moulding. Plate fabrication.

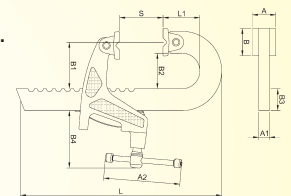

NEW

Product Number	Capacity (S)	Load (KN)	Weight Kg	A	A1	A2	B	B1	B2	B3	B4	L	L1	Order Code	Price/1 TB
SD150	150		1.3									279		IND-420 -7815K	4119.00
SD300	300		1.9									429		-7830K	5149.00
SD500	500	10	2.4	25	10	76	32	60	47	30	76	629	43.5	-7850K	5665.00
SD750	750		3.1									879		-7875K	6695.00

INDEXA Precision Ground Flat Stock

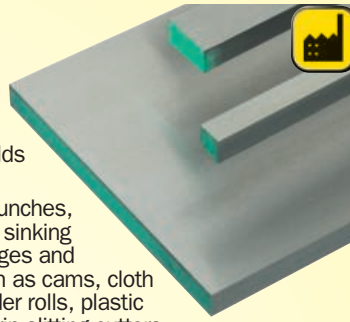

Precision ground flat stock supplied in **1.2510 (100MnCrW1)** Tool Steel, a wide range of Metric sizes. Oil hardening tool steel supplied in annealed condition. It offers good durability, gives excellent wear resistance and holds a good cutting edge. An excellent general purpose grade.

Applications include medium run dies, press tools, drawing punches, broaches, bushings, lathe centres, chuck jaws, master cavity sinking hobs, paper cutting machine knives, plug gauges, thread gauges and precision measuring tools. It is also used in applications such as cams, cloth cutting knives, cold taps, reamers, trimmer dies, tube expander rolls, plastic moulds and woodworking knives, collets, cutting hobs and strip slitting cutters.

Top & bottom surfaces will be supplied in ground condition. Both ends supplied sawn cut. Surface Roughness: Max 3.2 μ m.

Ground Flat Stock Tolerances

Thickness: -0/+0.005mm; Width: -0/+0.20mm; Length: -5/+5.00mm; Square Bars: -0/+0.10mm

Size (mm)	Order Code IND-413	Price/1 TB
2 x 10 x 500	-3300A	567.00
2 x 15 x 500	-3301B	670.00
2 x 20 x 500	-3302C	773.00
2 x 25 x 500	-3303D	824.00
2 x 40 x 500	-3305F	927.00
2 x 50 x 500	-3306G	953.00
3 x 10 x 500	-3400A	567.00
3 x 15 x 500	-3401B	670.00
3 x 20 x 500	-3402C	773.00
3 x 25 x 500	-3403D	824.00
3 x 30 x 500	-3404E	876.00
3 x 40 x 500	-3405F	927.00
3 x 50 x 500	-3406G	953.00
3 x 75 x 500	-3408J	1288.00
3 x 100 x 500	-3410L	1648.00
3 x 150 x 500	-3412N	2318.00
4 x 15 x 500	-3501B	670.00
4 x 20 x 500	-3502C	696.00
4 x 25 x 500	-3503D	773.00
4 x 30 x 500	-3504E	824.00
4 x 40 x 500	-3505F	927.00
4 x 50 x 500	-3506G	979.00
4 x 60 x 500	-3507H	1545.00
4 x 100 x 500	-3510L	1803.00
5 x 15 x 500	-3601B	824.00
5 x 20 x 500	-3602C	876.00
5 x 25 x 500	-3603D	927.00
5 x 30 x 500	-3604E	979.00
5 x 40 x 500	-3605F	1030.00
5 x 50 x 500	-3606G	1133.00
5 x 75 x 500	-3608J	1751.00
5 x 100 x 500	-3610L	1854.00
5 x 150 x 500	-3612N	2472.00
6 x 15 x 500	-3702C	927.00
6 x 20 x 500	-3703D	979.00
6 x 25 x 500	-3704E	1030.00
6 x 30 x 500	-3705F	1133.00
6 x 40 x 500	-3706G	1288.00
6 x 50 x 500	-3707H	1339.00
6 x 60 x 500	-3708J	1700.00
6 x 75 x 500	-3709K	1803.00
6 x 100 x 500	-3711M	2575.00
6 x 150 x 500	-3713P	2987.00
6 x 200 x 500	-3714Q	4017.00
8 x 15 x 500	-3802C	1159.00
8 x 20 x 500	-3803D	1164.00
8 x 25 x 500	-3804E	1442.00

Size (mm)	Order Code IND-413	Price/1 TB
8 x 30 x 500	-3805F	1545.00
8 x 40 x 500	-3806G	1648.00
8 x 50 x 500	-3807H	1700.00
8 x 60 x 500	-3808J	1957.00
8 x 75 x 500	-3809K	2936.00
8 x 100 x 500	-3811M	3089.00
8 x 150 x 500	-3813P	3296.00
10 x 10 x 500	-3900A	979.00
10 x 15 x 500	-3901B	1030.00
10 x 20 x 500	-3902C	1133.00
10 x 25 x 500	-3903D	1288.00
10 x 30 x 500	-3904E	1339.00
10 x 40 x 500	-3905F	2781.00
10 x 50 x 500	-3906G	2884.00
10 x 60 x 500	-3907H	2936.00
10 x 80 x 500	-3909K	3193.00
10 x 100 x 500	-3910L	3348.00
10 x 125 x 500	-3911M	3502.00
10 x 150 x 500	-3912N	4120.00
12 x 12 x 500	-4100A	1133.00
12 x 30 x 500	-4104E	1545.00
12 x 40 x 500	-4105F	1648.00
12 x 50 x 500	-4106G	1854.00
12 x 60 x 500	-4107H	2163.00
12 x 100 x 500	-4110L	3193.00
12 x 125 x 500	-4111M	3914.00
12 x 150 x 500	-4112N	4635.00
15 x 20 x 500	-4201B	1339.00
15 x 25 x 500	-4202C	1545.00
15 x 30 x 500	-4203D	1700.00
15 x 40 x 500	-4204E	1803.00
15 x 50 x 500	-4205F	2163.00
15 x 100 x 500	-4209K	3811.00
15 x 150 x 500	-4211M	5356.00
20 x 20 x 500	-4300A	1957.00
20 x 25 x 500	-4301B	2009.00
20 x 30 x 500	-4302C	2060.00
20 x 40 x 500	-4303D	2369.00
20 x 50 x 500	-4304E	2575.00
20 x 75 x 500	-4306G	4223.00
20 x 100 x 500	-4308J	4635.00
20 x 150 x 500	-4310L	6438.00
25 x 25 x 500	-4400A	2575.00
25 x 40 x 500	-4402C	2678.00
25 x 50 x 500	-4403D	3348.00
25 x 75 x 500	-4405F	4532.00

Industrial Key Steel

High grade mild steel. Available in square or rectangular sections.

Metric manufactured from: **BS4235 Part 7 1972 grade steel** equivalent to **DIN 6885**.

Inch manufactured from: **BS46 PART 7 1958 grade steel**. Length: 300mm and 12". Other sizes available on request.



Set Metric Square

Contents: 4, 5, 6, 8, 10 and 12mm.

No. of Pieces	Weight each	Order Code KEN-421	Price/1 TB
6	850g	-0500K	735.00

Square - Metric

Type	Size	Order Code KEN-421	Price/1 TB
mm	2mm	-0020K	208.00
	3mm	-0030K	208.00
	4mm	-0040K	175.00
	5mm	-0050K	148.00
	6mm	-0060K	154.00
	7mm	-0070K	205.00
	8mm	-0080K	175.00
	10mm	-0100K	191.00
	12mm	-0120K	202.00
	14mm	-0140K	338.00
	16mm	-0160K	382.00
	18mm	-0180K	599.00
	20mm	-0200K	817.00
	22mm	-0220K	925.00
25mm	-0250K	1360.00	

Square - Inch

Type	Size	Order Code KEN-421	Price/1 TB
inch	1/8"	-3080K	73.00
	5/32"	-3100K	83.00
	3/16"	-3120K	93.00
	1/4"	-3160K	121.00
	5/16"	-3200K	142.00
	3/8"	-3240K	164.00
	7/16"	-3280K	191.00
	1/2"	-3320K	229.00
	9/16"	-3360K	382.00
	5/8"	-3400K	382.00
	3/4"	-3480K	599.00
	7/8"	-3560K	817.00
	1"	-3640K	1035.00

Rectangular - Metric

Type	Size	Order Code KEN-421	Price/1 TB
mm	8 x 5mm	-0850K	308.00
	8 x 7mm	-0870K	229.00
	10 x 8mm	-1080K	300.00
	12 x 8mm	-1280K	322.00
	12 x 10mm	-1300K	338.00
	14 x 9mm	-1490K	490.00
	16 x 10mm	-1610K	707.00
	18 x 11mm	-1910K	763.00
	20 x 12mm	-2120K	925.00
	22 x 14mm	-2400K	1035.00
	25 x 14mm	-2420K	1197.00
	28 x 16mm	-2550K	1524.00
	32 x 18mm	-2650K	1633.00
	36 x 20mm	-2700K	1741.00

KENNEDY Steel Shim

Designed to achieve accurate alignment. High quality steel to prevent corrosion from exposure to acids or alkalis. With rounded corners, perfectly deburred for maximum safety. Permanent markings indicate thickness and dimensions. Extraction and insertion tabs facilitate positioning and removal of the shims.

EN2. CS4 fully hardened bright mild steel. 6" wide. 1lb tins.



Assorted pack
Contains one of each of the following thickness of shim:
0.002", 0.003", 0.004", 0.005", 0.006", 0.008", 0.010", 0.015".

Thickness	Length	Weight each	Order Code KEN-415	Price/1 TB
0.002"	24'4"	454g	-6020K	1236.00
0.003"	15'6"	454g	-6030K	1236.00
0.004"	12'2"	454g	-6040K	1133.00
0.005"	9'8"	454g	-6050K	927.00
0.006"	7'8"	454g	-6060K	876.00
0.007"	7'0"	454g	-6070K	824.00
0.008"	6'0"	454g	-6080K	824.00
0.010"	4'1"	454g	-6100K	773.00
0.012"	3'9"	454g	-6120K	773.00
0.015"	3'4"	454g	-6150K	773.00
0.020"	2'5"	454g	-6200K	721.00
0.025"	2'0"	454g	-6250K	721.00

Number of Pieces	Lengths	Weight each	Order Code KEN-415	Price/Pk TB
8	11"	0.60kg	-6650K	1236.00

8 PIECES





Designed to save set up time and solve most clamping problems. Manufactured to high standards. All step clamps are forged and hardened and the step blocks are made from high quality steel. All components (other than the studs) are heat treated and finished in black oxide. Available to suit a full range of metric and imperial T-Slot widths. Supplied in steel racks which can be wall mounted or fitted to workbenches for ease of storage (except M16 set which is supplied in wooden box).

WORKSHOP EQUIPMENT

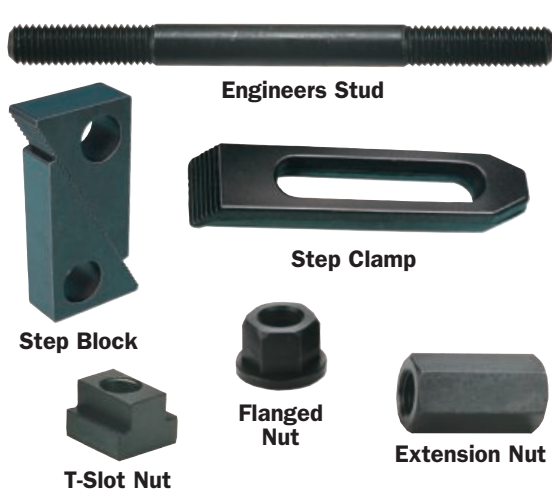

58 Pieces Metric Sets (Quantity of each component part given in brackets)

Product Number	Table Slot Size x W x L (mm)	Thread Size	Engineer's Stud L x Thread L (mm)	Step Clamp L x W x H (mm)	Extension Nuts	Flange Nuts	Step H	Blocks (Pairs) Adj. Range	Weight each	Order Code ATL-425	Price/1 TB
CK120100	12 x 18 x 14 (6)	M10	75 x 30 (4) 100 x 30 (4) 125 x 30 (4) 150 x 30 (4) 175 x 30 (4) 200 x 30 (4)	55 x 25 x 12 (2) 88 x 25 x 16 (2) 128 x 28 x 19 (2)	M10 x 30mm Long (4)	M10 x 15mm (6)	28 35 98	20 - 38 (4) 28 - 64 (4) 64 - 152 (4)	10kg	-1120K	2936.00
CK140120	14 x 22 x 16 (6)	M12	75 x 35 (4) 100 x 35 (4) 125 x 35 (4) 150 x 35 (4) 175 x 35 (4) 200 x 35 (4)	64 x 28 x 12 (2) 100 x 32 x 19 (2) 150 x 32 x 22 (2)	M12 x 36mm Long (4)	M12 x 18mm (6)	28 35 98	20 - 38 (4) 28 - 64 (4) 64 - 152 (4)	12kg	-1140K	3451.00
CK160140	16 x 25 x 18 (6)	M14	75 x 35 (4) 100 x 35 (4) 125 x 35 (4) 150 x 35 (4) 175 x 35 (4) 200 x 35 (4)	64 x 28 x 12 (2) 100 x 32 x 19 (2) 150 x 32 x 22 (2)	M14 x 42mm Long (4)	M14 x 21mm (6)	28 35 98	20 - 38 (4) 28 - 64 (4) 64 - 152 (4)	12kg	-1160K	4119.00
CK180140	18 x 25 x 18 (6)	M14	75 x 35 (4) 100 x 35 (4) 125 x 35 (4) 150 x 35 (4) 175 x 35 (4) 200 x 35 (4)	64 x 28 x 12 (2) 100 x 32 x 19 (2) 150 x 32 x 22 (2)	M14 x 42mm Long (4)	M14 x 21mm (6)	28 35 98	20 - 38 (4) 28 - 64 (4) 64 - 152 (4)	12kg	-1180K	4378.00
CK200160	20 x 28 x 20 (6)	M16	75 x 35 (4) 100 x 35 (4) 125 x 35 (4) 150 x 35 (4) 175 x 35 (4) 200 x 35 (4)	64 x 31 x 12 (2) 100 x 38 x 20 (2) 150 x 38 x 22 (2)	M16 x 48mm Long (4)	M16 x 24mm (6)	28 35 98	20 - 38 (4) 28 - 64 (4) 64 - 152 (4)	14kg	-1200K	5511.00

58 Pieces Inch Sets (Quantity of each component part given in brackets)

Product Number	Table Slot Size x W x L (mm)	Thread Size	Engineer's Stud L x Thread L (mm)	Step Clamp L x H x W (mm)	Extension Nuts	Flange Nuts	Step H	Blocks (Pairs) Adj. Range	Weight each	Order Code ATL-425	Price/1 TB
CK500375	1/2" x 1 11/16" x 17/32" (6)	3/8" UNC	3" x 1 1/4" (4) 4" x 1 1/4" (4) 5" x 1 1/4" (4) 6" x 1 1/4" (4) 7" x 1 1/4" (4) 8" x 1 1/4" (4)	2" x 1" x 1/2" (2) 3 1/2" x 1 1/4" x 3/4" (2) 5" x 1 1/4" x 7/8" (2)	3/8" UNC x 1" Long (4)	3/8" UNC 7/16" (6)	1 1/8" 1 3/4" 3 7/8"	3/4" - 1 1/2" (4) 1 1/8" - 2 1/2" (4) 2 1/2" - 6" (4)	10kg	-1320K	2163.00
CK62500	9/16" x 7/8" x 6/8" (6)	1/2" UNC	3" x 1 1/4" (4) 4" x 1 1/2" (4) 5" x 1 1/2" (4) 6" x 1 1/2" (4) 7" x 1 1/2" (4) 8" x 1 1/2" (4)	2 1/2" x 1 1/8" x 1/2" (2) 2" x 1 1/4" x 3/4" (2) 6" x 1 1/4" x 7/8" (2)	1/2" UNC x 1 1/4" Long (4)	1/2" UNC 13/16" (6)	1 1/8" 1 3/4" 3 7/8"	3/4" - 1 1/2" (4) 1 1/8" - 2 1/2" (4) 2 1/2" - 6" (4)	12kg	-1360K	2575.00
CK62550	5/8" x 7/8" x 6/8" (6)	1/2" UNC	3" x 1 1/4" (4) 4" x 1 1/2" (4) 5" x 1 1/2" (4) 6" x 1 1/2" (4) 7" x 1 1/2" (4) 8" x 1 1/2" (4)	2 1/2" x 1 1/8" x 1/2" (2) 2" x 1 1/4" x 3/4" (2) 6" x 1 1/4" x 7/8" (2)	1/2" UNC x 1 1/4" Long (4)	1/2" UNC 13/16" (6)	1 1/8" 1 3/4" 3 7/8"	3/4" - 1 1/2" (4) 1 1/8" - 2 1/2" (4) 2 1/2" - 6" (4)	12kg	-1400K	2936.00
CK750625	3/4" x 1 3/8" x 1 1/8" (6)	5/8" UNC	3" x 1 1/4" (4) 4" x 1 1/2" (4) 5" x 1 1/2" (4) 6" x 1 1/2" (4) 7" x 1 1/2" (4) 8" x 1 1/2" (4)	2 1/2" x 1 1/8" x 1/2" (2) 2" x 1 1/4" x 3/4" (2) 6" x 1 1/4" x 7/8" (2)	5/8" UNC x 1 5/8" Long (4)	5/8" UNC 13/16" (6)	1 1/8" 1 3/4" 3 7/8"	3/4" - 1 1/2" (4) 1 1/8" - 2 1/2" (4) 2 1/2" - 6" (4)	12kg	-1480K	5047.00



INDEXA *Indexa T-Slot Clamping Kits*

Designed to save set up time and solve most T-Slot clamping problems. All components are manufactured from **S45C (JIS)/CK45 (DIN)** grade non-alloy carbon steel, heat treated to HRC 28 - 32 and have a manganese phosphate surface finish. Supplied in a robust plastic case.

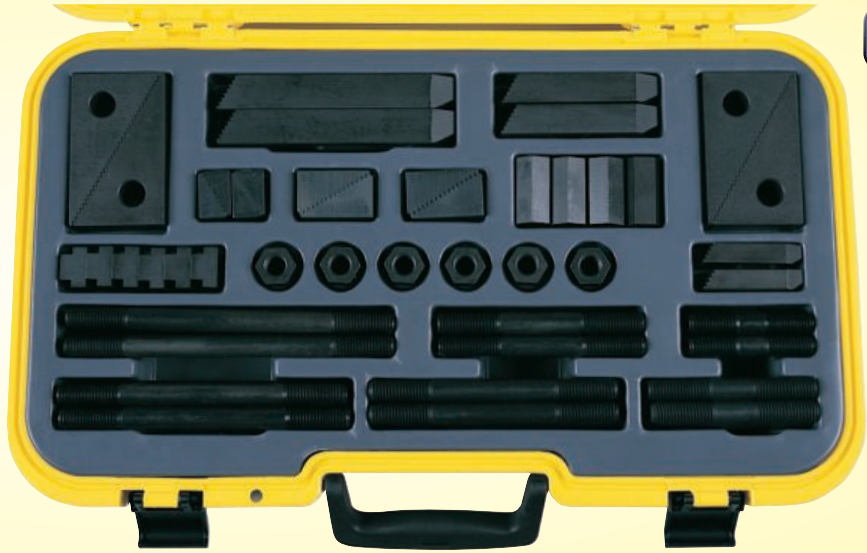

T-Slot Size	Thread Size	Part Number	Weight each	Order Code IND-425	Price/1 TB
12mm	M10	TK10	9.0kg	-3610T	15193.00
14mm	M12	TK12	10.0kg	-3612T	15500.00
16mm	M14	TK14	11.0kg	-3614T	16995.00
18mm	M16	TK16	14.0kg	-3616T	23175.00
20mm	M18	TK18	20.5kg	-3618T	26265.00

INDEXA *CC01 - U-Clamp*

Open end permits quick and easy installation.



Material: Medium Carbon Steel.
Heat treated to: HRC 32 - 38.
Surface finish: Black Oxide.

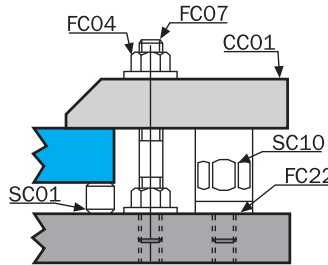
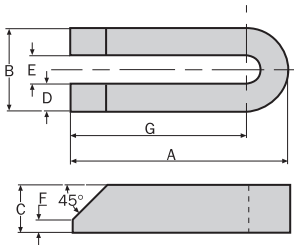

Product Number	Length x Width A x B	Dimensions (mm)					Weight each	Order Code IND-425	Price/1 TB
		C	D	E	F	G			
CC010112	100 x 38mm	22	12.5	13	6	81	0.41kg	-1005D	773.00
CC010316	150 x 50mm	30	16.5	17	8	125	1.10kg	-1005J	1367.00
CC010420	200 x 60mm	35	19.5	21	10	170	2.10kg	-1005M	3388.00

CC02 - Bore Clamp

The cylindrical pin minimises the contact area. This clamp is for clamping inside horizontal bores and onto concave surfaces.

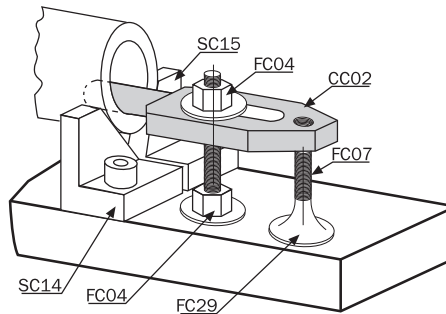
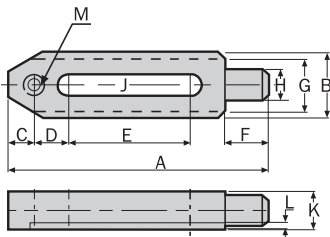

Material: Medium Carbon Steel.
Heat treated to: HR C32 - 38.
Surface finish: Black Oxide.



Product Number	Length x Width A x B	Dimensions (mm)										Weight each	Order Code IND-425	Price/1 TB
		C	D	E	F	G	H	J	K	L	M			
CC020112	150 x 38mm	15	20	70	25	30	18	13	22	4	M12	0.58kg	-1010D	1149.00
CC020216	150 x 48mm	20	25	40	35	40	24	17	32	5	M16	1.12kg	-1010G	1444.00

CC03 - Swan Necked Clamp

Low profile design helps eliminate cutter interference.

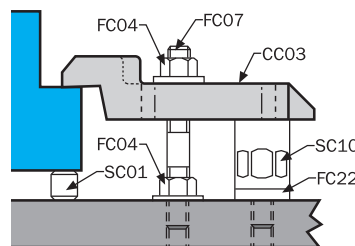
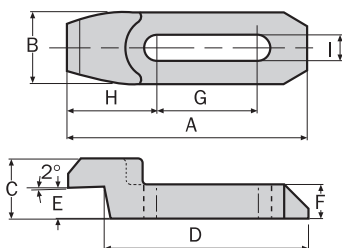

Material: Medium Carbon Steel.
Heat treated to: HRC 32 - 38.
Surface finish: Black Oxide.



Product Number	Length x Width A x B	Dimensions (mm)							Weight each	Order Code IND-425	Price/1 TB
		C	D	E	F	G	H	I			
CC030216	150 x 48mm	48	130	25	25	55	60	17	1.30kg	-1015K	2351.00
CC030320	175 x 60mm	60	150	30	30	65	70	21	2.26kg	-1015N	3651.00
CC030112	120 x 36mm	30	102	16	17	50	45	13	0.49kg	-1015H	1640.00

PRODUCTS ARE ONLY AVAILABLE VIA YOUR DISTRIBUTOR

INDEXA CC04 - Tapped End U-Clamp

Open end design permits easy assembly.



Material: Medium Carbon Steel.
Heat treated to: HRC 32 - 38.
Surface finish: Black Oxide.

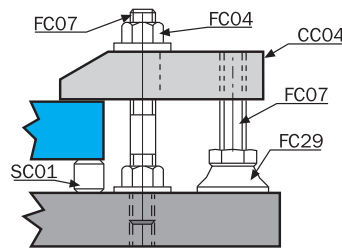
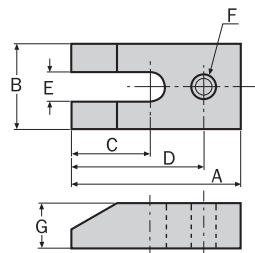

Product Number	Length x Width A x B	Dimensions (mm)					Weight each	Order Code IND-425	Price/1 TB
		C	D	E	F	G			
CC040616	150 x 50mm	95	130	17	M16	25	1.50kg	-1020R	1996.00

CC05 - Plain Clamp

Material: Medium Carbon Steel.
Heat treated to: HRC 32 - 38.
Surface finish: Black Oxide.

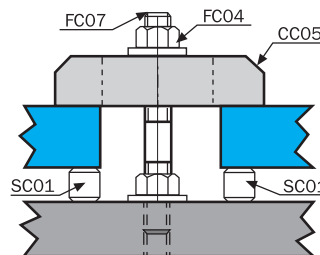
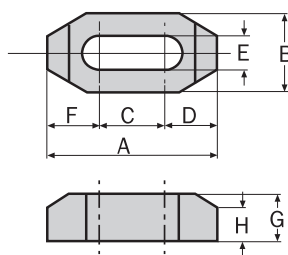

Product Number	Length x Width A x B	Dimensions (mm)						Weight each	Order Code IND-425	Price/1 TB
		C	D	E	F	G	H			
CC050112	65 x 32mm	25	20.0	13	20.0	19	13	0.22kg	-1025D	773.00
CC050212	100 x 32mm	40	30.0	13	30.0	19	13	0.33kg	-1025G	1067.00
CC050316	80 x 38mm	24	28.0	17	28.0	22	14	0.34kg	-1025J	782.00
CC050416	125 x 38mm	41	42.0	17	42.0	22	14	0.57kg	-1025M	1040.00
CC050520	100 x 38mm	32	34.0	21	34.0	22	14	0.41kg	-1025P	1092.00
CC050620	125 x 38mm	40	42.5	21	42.5	25	15	0.62kg	-1025R	1258.00

CC06 - Tapped End Plain Clamp

For use with various knobs, jack screws, clamps and pads.

Material: Medium Carbon Steel.
Heat treated to: HRC 32 - 38.
Surface finish: Black Oxide.

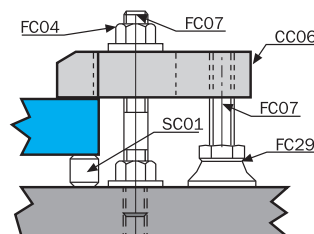
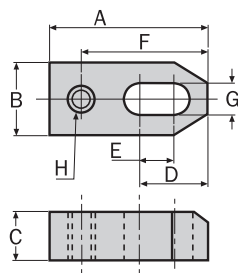

Product Number	Length x Width A x B	Dimensions (mm)						Weight each	Order Code IND-425	Price/1 TB
		C	D	E	F	G	H			
CC060112	65 x 32mm	19	32	14	52	13	M12	0.22kg	-1030D	603.00
CC060212	80 x 32mm	19	48	25	69	13	M12	0.27kg	-1030F	765.00
CC060312	100 x 32mm	19	60	40	89	13	M12	0.33kg	-1030H	931.00
CC060416	80 x 38mm	19	40	17	65	17	M16	0.32kg	-1030J	821.00
CC060516	100 x 38mm	25	55	30	85	17	M16	0.53kg	-1030L	1149.00
CC060616	125 x 38mm	25	70	45	110	17	M16	0.65kg	-1030N	1313.00
CC060720	150 x 50mm	25	82	50	134	21	M20	1.10kg	-1030P	1777.00
CC060820	200 x 50mm	25	112	80	184	21	M20	1.90kg	-1030R	2323.00

INDEXA CC07 - Slotted End Clamp



Material: Medium Carbon Steel.
Hardness: HRC 32 - 38.
Surface finish: Black Oxide.

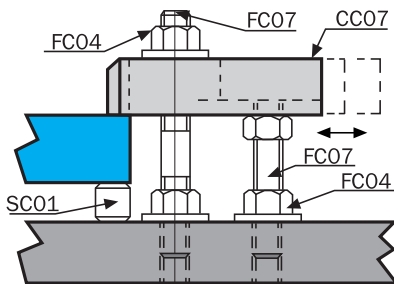
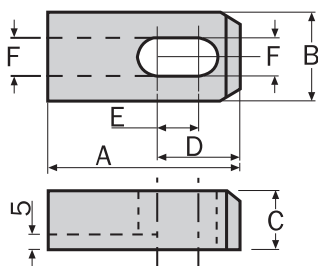

Product Number	Length x Width A x B	Dimensions (mm)					Weight each	Order Code IND-425	Price/1 TB
		C	D	E	F	L			
CC070212	80 x 32mm	22	48	25	13	0.31kg	-1035F	729.00	
CC070616	125 x 38mm	25	70	45	17	0.65kg	-1035N	1176.00	

CC08 - Swing Clamp

A small clamp with good holding power, ideal for tight spaces, full swing away feature permits easy part loading.

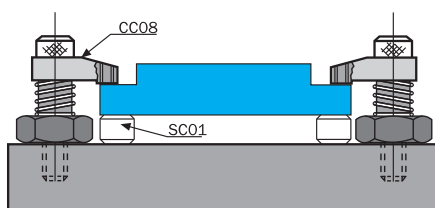
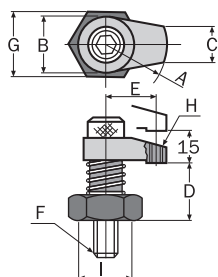

Material: Case Hardened Steel.
Hardness: HRC 38 - 42.
Surface finish: Black Oxide.



Product Number	Length x Width A x B	Dimensions (mm)							Weight each	Order Code IND-425	Price/1 TB
		C	D	E	F	G	H	I			
CC080112	30 x 28mm	16	40	-	M12	29	-	21	0.29kg	-1040D	2351.00
CC080212	50 x 32mm	20	45	40	M12	36	M12	26	0.50kg	-1040G	2788.00
CC080316	60 x 40mm	25	45	45	M16	41	M16	32	0.75kg	-1040J	3416.00

CC11 - Free Vise Jaw

Clamping force in two directions, with serrated jaws for holding large or irregular shapes.

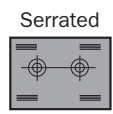
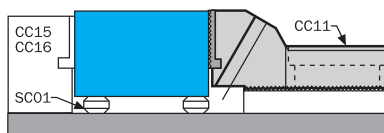
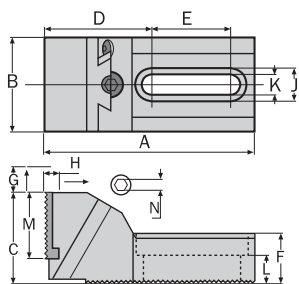

Material: Body: Grey Cast Iron.
Jaw: Medium Carbon Steel EN8D.
Hardness: Jaw Only: HRC 45 - 48.
Surface finish: Jaw: Black Oxide.



Product Number	Type	Length x Width A x B	Dimensions (mm)											Weight each	Order Code IND-425	Price/1 TB
			C	D	E	F	G	H	J	K	L	M	N			
CC110112	Serrated	133 x 60mm	54.5	68	50	32	16	6	22	13	16.8	42	10	2.0kg	-1045D	11858.00

CC12 - Adjustable Clamp

Low profile clamp that keeps top surfaces clear for machining. Ideal for rough or finished parts.

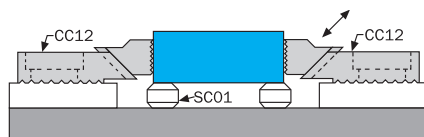
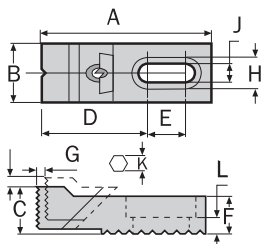

Material: Medium Carbon Steel.
Hardness: Jaw Only: HRC 38.
Surface finish: Black Oxide.
Jaws: Surface treated with high frequency quenching.



Product Number	Type	Length x Width x Height A x B x C	Dimensions (mm)							Weight each	Order Code IND-425	Price/1 TB	
			D	E	F	G	H	J	K				L
CC120108		73.45 x 25 x 18mm	46.95	16.5	16	7	14	8.5	4	7	0.18kg	-1050D	3717.00
CC120212	Serrated	106.64 x 35 x 27.5mm	62.14	30.0	22	12	20	13.5	6	9	0.52kg	-1050F	4427.00
CC120316		134.64 x 40 x 37.5mm	82.14	35.0	30	14	26	17.0	8	13	1.02kg	-1050H	5629.00
CC120408		72.00 x 25 x 20.0mm	45.00	16.0	16	7	14	8.5	4	7	0.16kg	-1050J	3601.00
CC120512	Ground	104.64 x 35 x 27.5mm	62.14	30.0	22	12	20	13.5	6	9	0.52kg	-1050M	4208.00
CC120616		134.64 x 40 x 37.5mm	82.14	35.0	30	14	26	17.0	8	13	1.02kg	-1050R	7159.00

PRODUCTS ARE ONLY AVAILABLE VIA YOUR DISTRIBUTOR

**INDEXA CC13 -
Adjustable Stepped Clamp**

Low profile clamp for holding thin parts and keeping top surfaces clear for machining.



Material: Medium Carbon Steel.
Heat treated to: HRC 38.
Surface finish: Black Oxide.
Jaws: Surface treated with high frequency quenching.

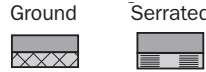
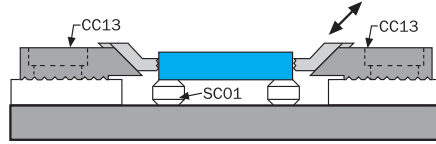
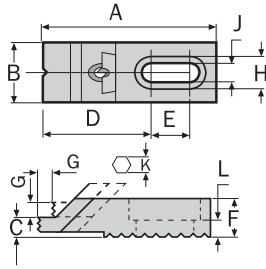

Product Number	Type	Length x Width x Height A x B x C	Dimensions (mm)								Weight each	Order Code IND-425	Price/1 TB
			D	E	F	G	H	J	K	L			
CC130108	Serrated	73.45 x 25 x 18mm	46.95	16.5	16.5	7	14	8.5	5	7	0.18kg	-1055D	5410.00
CC130212		106.64 x 35 x 27.5mm	64.14	30.0	22.0	12	20	13.5	6	9	0.52kg	-1055F	4371.00
CC130316	Ground	133.14 x 40 x 14mm	90.00	30.0	30.0	14	26	17.0	8	13	0.85kg	-1055H	5137.00
CC130512		105 x 35 x 27.5mm	64.14	26.0	22.0	12	20	13.5	6	9	0.52kg	-1055M	4371.00

CC19 - Forged Swivel Clamp

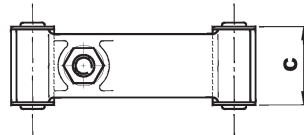
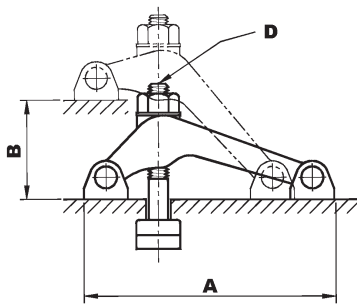

Material: Medium Carbon Steel/Steel Forging.
Heat treated to: 32 - 38°.
Surface finish: Black Oxide.



Product Number	Length x Width A x B	Dimensions (mm)		Weight each	Order Code IND-425	Price/1 TB
		C	D			
CC19-NC50	131 x 75mm	46.5	M12-125	1.50kg	-1085D	4481.00

CC20 - Forged Swivel Clamp

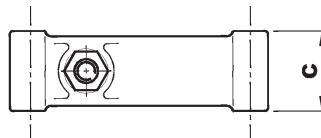
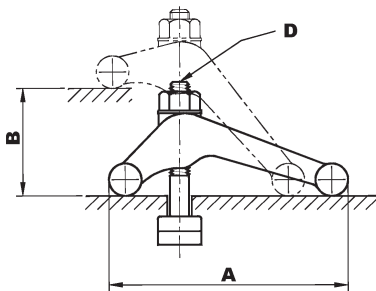

Material: Medium Carbon Steel/Steel Forging.
Heat treated to: 32 - 38°.
Surface finish: Black Oxide.



Product Number	Length x Width A x B	Dimensions (mm)		Weight each	Order Code IND-425	Price/1 TB
		C	D			
CC20-NC6	150 x 85mm	52	M16-150	2.42kg	-1090M	3278.00
CC20-NC8	194 x 105mm	58	M20-175	4.50kg	-1090T	4590.00

CC21 - Swivel Rack Clamp

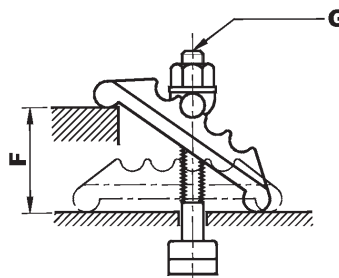
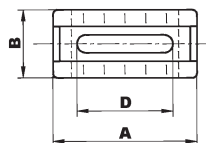
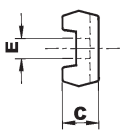

Material: Medium Carbon Steel/Steel Forging.
Surface finish: Black Oxide.



Product Number	Length x Width A x B	Dimensions (mm)					Weight each	Order Code IND-425	Price/1 TB
		C	D	E	F	G			
CC21-0216	125 x 56mm	33	84	18	65	M16	2.10kg	-1095M	3251.00

INDEXA

CC24 - Eccentric Cam Lock

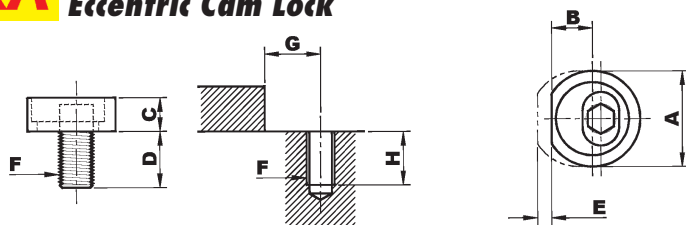

Material: Medium Carbon Steel.
Hardness: HRC 35.
Surface finish: Black Oxide.



Product Number	Dimensions (mm)								Weight each	Order Code	Price/1 TB
	A	B	C	D	E	F	G	H			
CC240210	26	11.8	8	14.3	4	M10	12.5	22	.03kg	-1110C	903.00
CC240312	30	13.5	9	19	5	M12	14.5	22	.06kg	-1110G	983.00
CC240416	38	16.0	12	23	6	M16	17.5	26	.12kg	-1110P	1176.00

CC25 - Step Clamp

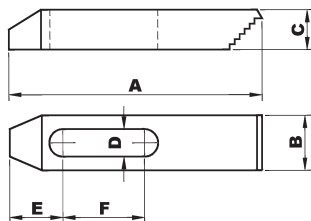

Material: Medium Carbon Steel.
Hardness: HRC 32 - 38.
Surface finish: Black Oxide.

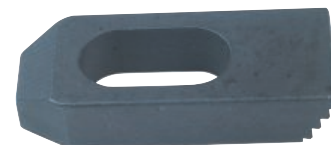

Product Number	Length x Width A x B	Dimensions (mm)				To Suit Stud Size	Weight each	Order Code	Price/1 TB
		C	D	E	F				
CC251463	63 x 25mm	13	15	20	14	M14	0.12kg	-1130C	466.00
CC2514100	100 x 32mm	19	15	29	34	M14	0.38kg	-1130G	629.00
CC2514150	150 x 32mm	22	15	32	50	M14	0.68kg	-1130J	738.00
CC2516100	100 x 32mm	19	17	31	26	M16	0.42kg	-1135G	546.00
CC2516150	150 x 30mm	22	17	40	47	M16	0.72kg	-1135J	874.00



Step Clamp

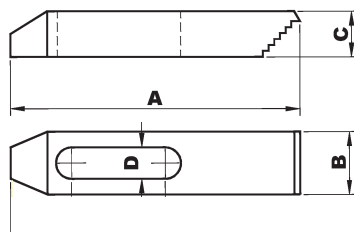

Material: Medium Carbon Steel.
Hardness: HRC 32 - 38.
Surface finish: Black Oxide.



Product Number	To Suit Stud Size	Dimensions (mm)				Order Code	Price/1 TB	Product Number	To Suit Stud Size	Dimensions (mm)				Order Code	Price/1 TB
		A x B	C	D	ATL-425					A x B	C	D	ATL-425		
SC105222		55 x 25	12	13	-2020K	260.00	SC146428		64 x 28	12	15	-2220K	549.00		
SC108825	M10 ^{3/8} " UNC	88 x 25	16	11	-2040K	386.00	SC1410035	M14	100 x 35	19	15	-2240K	504.00		
SC1012828		128 x 28	19	11	-2060K	495.00	SC1415032		150 x 32	22	15	-2260K	549.00		
SC126428		64 x 28	12	13	-2120K	260.00	SC166432		64 x 32	12	17	-2420K	280.00		
SC1210032	M12 ^{1/2} " UNC	100 x 32	19	13	-2140K	386.00	SC1610038	M16 ^{5/8} " UNC	100 x 38	20	17	-2440K	499.00		
SC1215032		150 x 32	22	13	-2160K	549.00	SC1615038		150 x 38	22	17	-2460K	618.00		

INDEXA

FC01 - Plain Ball End

Precision swivel ball that can be used either as a contact bolt or rest pad. As contact pads these swivel ball units are ideal for evenly distributing clamping pressure on sloped or uneven surfaces.

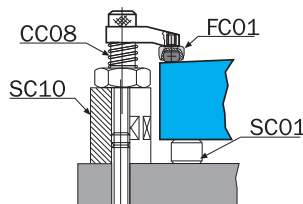
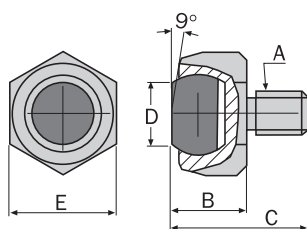

Material:
Body - Medium Carbon Steel.
Ball - Through Hardened Steel
EN 31.
Hardness:
Bolt - HRC 35.
Ball - HRC 62.
Surface finish:
Black Oxide.



Product Number	Thread A	Dimensions (mm)				Weight each	Order Code	Price/1 TB
		B	C	D	E			
FC010216	M16 x 2.00	26	42	14	27	0.14kg	-2010R	1367.00

FC02 - Serrated Ball End

Precision swivel ball that can be used either as a contact bolt or rest pad. As contact pads these swivel ball units are ideal for evenly distributing clamping pressure on sloped or uneven surfaces.

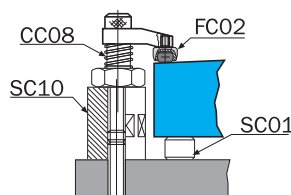
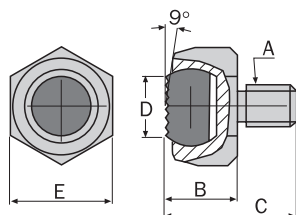

Material:
Body - Medium Carbon Steel.
Ball - Through Hardened Steel
EN 31.
Hardness:
Bolt - HRC 35.
Ball - HRC 62.
Surface finish:
Black Oxide.



Product Number	Thread A	Dimensions (mm)				Weight each	Order Code	Price/1 TB
		B	C	D	E			
FC010112	M12 x 1.75	22	35	12	22	0.070kg	-2015J	1367.00
FC010216	M16 x 2.00	26	42	14	27	0.14kg	-2015R	1859.00

PRODUCTS ARE ONLY AVAILABLE VIA YOUR DISTRIBUTOR

INDEXA FC04 - Flanged Nut



Material: Medium Carbon Steel.
Hardness: HRC 30 - 35.
Surface finish: Black Oxide.

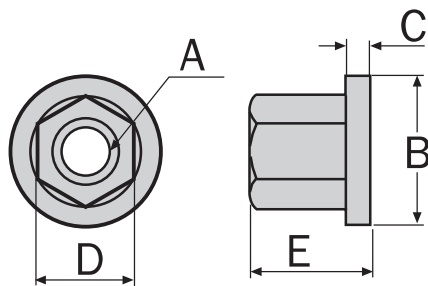

Product Number	Thread	Dimensions (mm)				Weight each	Order Code IND-425	Price/1 TB
		B	C	D	E			
FC040110	M10	22	3	17	13	0.020kg	-2025G	137.00
FC040212	M12	28	4	19	17	0.040kg	-2025K	144.00
FC040214	M14	28	4	22	17	0.040kg	-2025M	159.00
FC040316	M16	33	5	24	20	0.060kg	-2025P	176.00
FC040420	M20	40	6	30	25	0.110kg	-2025T	324.00

FC05 - Extension Nut

Extends the length of clamping studs.

Material: Medium Carbon Steel.
Hardness: HRC 30 - 35.
Surface Finish: Black Oxide.

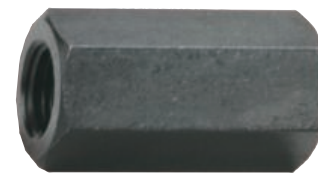
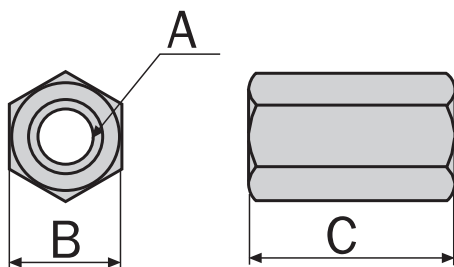

Product Number	Size	Dimensions (mm)		Weight each	Order Code IND-425	Price/1 TB
		B	C			
FC050110	M10	17	30	0.030kg	-2030F	137.00
FC050212	M12	19	36	0.046kg	-2030K	192.00
FC050314	M14	22	42	0.065kg	-2030M	215.00
FC050316	M16	24	48	0.110kg	-2030N	357.00
FC050420	M20	30	60	0.220kg	-2030R	410.00

FC06 - T-Slot Nut (Milled)

Material: Medium Carbon Steel.
Hardness: HRC 30 - 35.
Surface finish: Black Oxide.

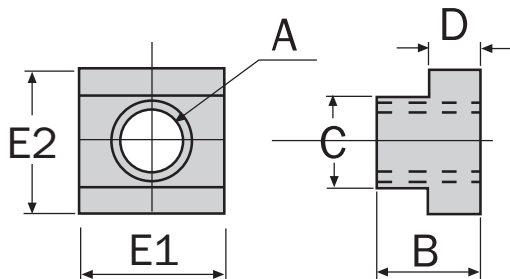

Product Number	Size	Dimensions (mm)					Weight each	Order Code IND-425	Price/1 TB
		B	C	D	E1	E2			
FC060110	M10	14.0	11.8	7.0	22	18.0	0.022kg	-2035G	126.00
FC060212	M12	16.0	13.8	8.0	28	22.0	0.048kg	-2035K	137.00
FC050314	M14	16.0	15.8	8.0	28	25.0	0.057kg	-2035M	192.00
FC060316	M16	20.0	17.7	10.5	30	28.5	0.085kg	-2035P	215.00
FC060420	M20	25.0	22.0	14.0	38	36.0	0.190kg	-2035T	301.00

INDEXA FC07 - Engineer's Stud

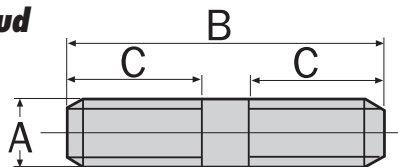

Material: Medium Carbon Steel.
Hardness: HRC 30 - 35.
Surface finish: Black Oxide.



WORKSHOP EQUIPMENT

Product Number	Size A x B	Dimension C	Weight each	Order Code IND-425	Price/1 TB
FC070110	M10 x 50mm	22	30g	-2120S	83.00
FC070210	M10 x 75mm	30	42g	-2125S	88.00
FC070310	M10 x 100mm	38	55g	-2130S	105.00
FC070510	M10 x 150mm	50	90g	-2140S	126.00
FC070612	M12 x 50mm	22	40g	-2145S	105.00
FC070712	M12 x 75mm	30	60g	-2150S	126.00
FC070812	M12 x 100mm	38	80g	-2155S	170.00
FC070912	M12 x 125mm	38	100g	-2160S	170.00
FC071012	M12 x 150mm	50	125g	-2165S	182.00
FC071112	M12 x 200mm	65	160g	-2170S	215.00
FC071212	M12 x 300mm	80	240g	-2175S	235.00
FC071214	M14 x 75mm	30	65g	-2176S	149.00
FC071214	M14 x 100mm	38	85g	-2177A	159.00
FC071214	M14 x 125mm	38	105g	-2177G	186.00
FC071214	M14 x 150mm	50	130g	-2177K	209.00
FC071214	M14 x 200mm	65	165g	-2177T	247.00
FC071316	M16 x 75mm	20	120g	-2180S	165.00
FC071416	M16 x 100mm	38	145g	-2185S	182.00
FC071516	M16 x 125mm	38	180g	-2190S	215.00
FC071616	M16 x 150mm	50	230g	-2195S	230.00
FC071616	M16 x 175mm	50	240g	-2197S	274.00
FC071716	M16 x 200mm	65	290g	-2200S	291.00
FC071816	M16 x 250mm	65	350g	-2205S	357.00
FC071916	M16 x 300mm	80	450g	-2210S	400.00
FC072016	M16 x 400mm	100	580g	-2215S	454.00
FC072116	M16 x 500mm	100	700g	-2220S	603.00
FC072220	M20 x 75mm	30	170g	-2225S	215.00
FC072320	M20 x 100mm	38	230g	-2230S	235.00
FC072420	M20 x 125mm	38	280g	-2235S	324.00
FC072520	M20 x 150mm	50	360g	-2240S	345.00
FC072620	M20 x 200mm	65	450g	-2245S	357.00
FC072720	M20 x 250mm	65	550g	-2250S	410.00
FC072820	M20 x 300mm	80	700g	-2255S	493.00
FC072920	M20 x 400mm	100	880g	-2260S	629.00
FC073020	M20 x 500mm	100	1100g	-2265S	738.00

FC08 - T-Slot Nut (Ground)

Ground surfaces provide accurate positioning inside of T-slot.

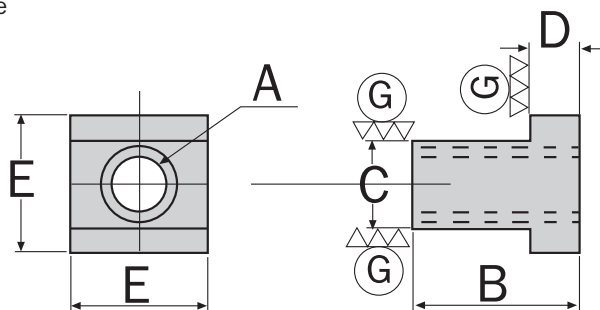

Material: Medium Carbon Steel.
Hardness: HRC 30 - 35.



Product Number	Thread A	Dimensions (mm)				Weight each	Order Code IND-425	Price/1 TB
		B	C (h6)	D	E			
FC008112	M12	22	14	8	22	45g	-2505J	738.00
FC008216	M16	30	18	10	28	80g	-2505R	761.00

FC09 - Swing Bolt

Reamed hole for smooth swivelling.

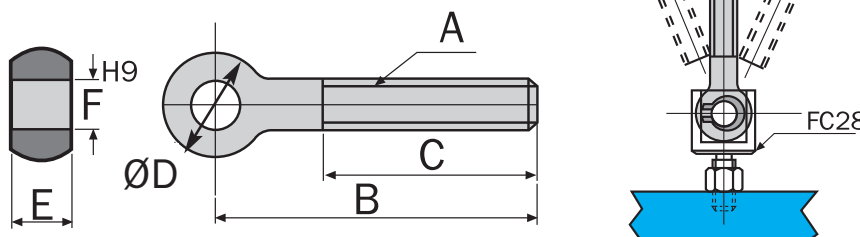

Material: Medium Carbon Steel.
Hardness: HRC 30 - 35.



Product Number	Size A x B	Dimensions (mm)				Weight each	Order Code IND-425	Price/1 TB
		C	D	E	F			
FC040110	M10 x 75mm	40	20	12	10	60g	-2510E	1203.00
FC090210	M10 x 100mm	40	20	12	10	80g	-2510H	1503.00
FC090412	M12 x 100mm	60	25	14	12	120g	-2510N	1612.00
FC090516	M16 x 125mm	60	32	17	16	250g	-2510P	1914.00
FC090616	M16 x 150mm	75	32	17	16	300g	-2510R	1963.00

INDEXA FC16 - Swivel Clamping Screw

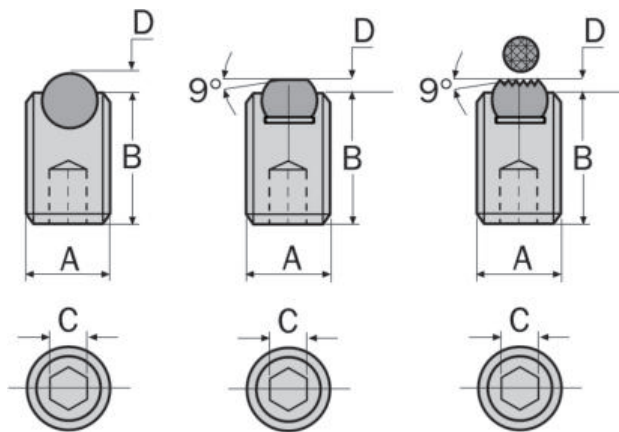

Material:
 Body - Medium Carbon Steel **EN198**.
 Point - Through Hardened Steel **EN 31**.
Hardness:
 Body - HRC 32 - 38.
 Point - HRC 62.
Surface finish:
 Point - Hardened and Ground.



Ball Point Dog Point Serrated Point

Ball Point					Dog Point					Serrated Point				
Thread x Length	mm	Weight	Product	mm	Order Code	Price/1	Product	mm	Order Code	Price/1	Product	mm	Order Code	Price/1
A x B	C	each	Number	D	IND-425	TB	Number	D	IND-425	TB	Number	D	IND-425	TB
M6 x 15mm	3	2.4g	FC160206	1.4	-2610H	274.00	-	-	-	-	-	-	-	-
M6 x 25mm	3	3.8g	FC160306	1.4	-2610N	280.00	-	-	-	-	-	-	-	-
M8 x 12mm	4	3.2g	FC160408	1.9	-2615D	280.00	FC162208	0.6	-2645D	324.00	-	-	-	-
M8 x 20mm	4	5.8g	FC160508	1.9	-2615H	280.00	FC162308	0.6	-2645H	469.00	-	-	-	-
M8 x 30mm	4	9.0g	FC160608	1.9	-2615N	280.00	-	-	-	-	-	-	-	-
M10 x 15mm	5	6.7g	FC160710	2.4	-2620D	280.00	-	-	-	-	-	-	-	-
M10 x 25mm	5	11.2g	FC160810	2.4	-2620H	301.00	FC162610	0.7	-2650H	469.00	-	-	-	-
M10 x 35mm	5	16.2g	-	-	-	-	FC162710	0.7	-2650N	542.00	-	-	-	-
M12 x 30mm	6	20.0g	-	-	-	-	FC162912	0.9	-2655H	738.00	-	-	-	-
M12 x 50mm	6	40.0g	FC161312	2.9	-2625T	493.00	-	-	-	-	-	-	-	-
M16 x 55mm	8	55.0g	-	-	-	-	FC163516	1.0	-2660R	1203.00	-	-	-	-
M16 x 65mm	8	65.0g	-	-	-	-	-	-	-	-	FC165416	1.0	-2690T	1203.00

FC17 - Swivel Shoulder Clamping Screw

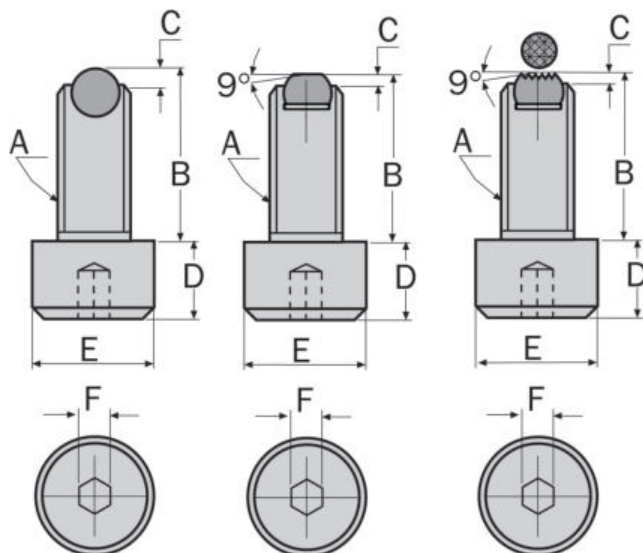

Material:
 Body - Medium Carbon Steel **EN198**.
 Point - Through Hardened Steel **EN 31**.
Hardness:
 Body - HRC 32 - 38.
 Point - HRC 62.
Surface finish:
 Point - Hardened and Ground.



Ball Point Dog Point Serrated Point

Ball Point						Dog Point						Serrated Point					
Thread x L	Dimensions	Weight	Product	mm	Order Code	Price/1	Product	mm	Order Code	Price/1	Product	mm	Order Code	Price/1			
A x B (mm)	D E F	each	Number	C	IND-425	TB	Number	C	IND-425	TB	Number	C	IND-425	TB			
M8 x 40	8 13 6	24g	FC170608	1.9	-2725N	215.00	-	-	-	-	-	-	-	-			
M12 x 65	12 18 10	70g	FC171212	2.9	-2735N	542.00	-	-	-	-	-	-	-	-			
M16 x 40	16 24 14	90g	FC171416	4.0	-2740D	575.00	-	-	-	-	-	-	-	-			

INDEXA FC18 - Grip Point Screw

Multipurpose work support and clamping unit, ideal for rough parts.

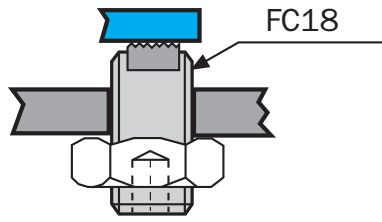
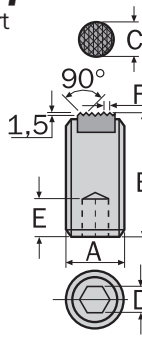

Material: Medium Carbon Steel EN19B.
Hardness: HRC 32 - 38.
 Tooth plate HRC 60.
Serrated surface: Induction Hardened.
Surface finish: Black Oxide.



Product Number	Thread x Length A x B	Dimensions (mm)				Weight each
		C	D	E	F	
FC180110	M10 x 25mm	6.5	5	4	2.3	15g
FC180616	M16 x 50mm	11.5	8	6	3.0	78g

Order Code	Price/1 TB
IND-425	
-2825D	437.00
-2825R	384.00

FC21 - Round Grip Pad

Multipurpose work support and clamping unit, ideal for rough parts.

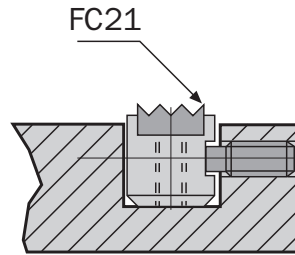
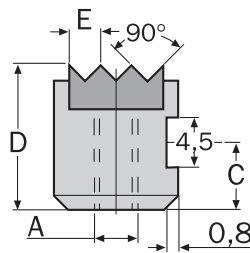
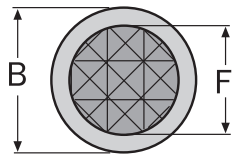

Material: Hardened Steel EN16M.
Hardness: HRC 60.
Surface finish: Black Oxide.



Product Number	Thread x Dia A x B	Dimensions (mm)				Weight each
		C	D	E	F	
FC210110	M5 x 10mm	3.4	10	2.3	8.1	5g
FC210212	M6 x 12mm	4.0	12	3.0	9.6	8g
FC210525	M6 x 25mm	4.0	12	3.0	19.5	40g

Order Code	Price/1 TB
IND-425	
-2840D	493.00
-2840G	546.00
-2840P	449.00

FC22 - Spacer

For use with jig components for increasing height or extending length.

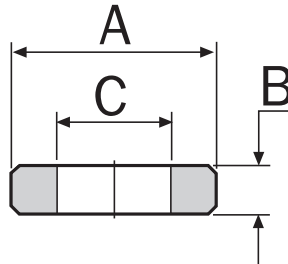

Material: Medium Carbon Steel.
Hardness: HRC 40.

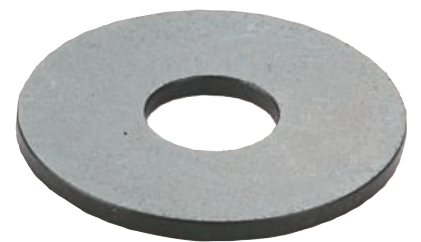

Product Number	Dimensions (mm)			Weight each
	A	B	C	
FC220616	50	5	17	70g
FC220716	50	10	17	350g

Order Code	Price/1 TB
IND-425	
-2845P	847.00
-2845T	847.00

FC23 - 'C' Washer

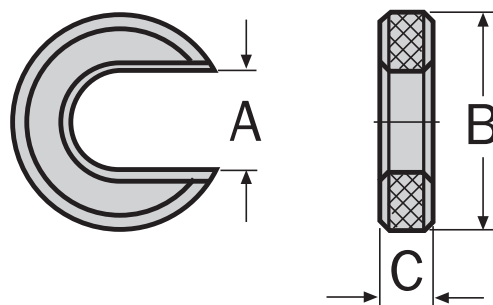

Material: Medium Carbon Steel.
Hardness: HRC 40.
Surface finish: Black Oxide.



Product Number	Dimensions (mm)			Weight each
	A	B	C	
CC010212	13	55	10	150g

Order Code	Price/1 TB
IND-425	
-2850G	765.00

GROUP 425 CLAMPING FIXTURES

INDEXA FC29 - Swivel Foot

Used for supporting uneven surfaces.



Material: Medium Carbon Steel.
Hardness: HRC 32 - 38.
Surface finish: Black Oxide.

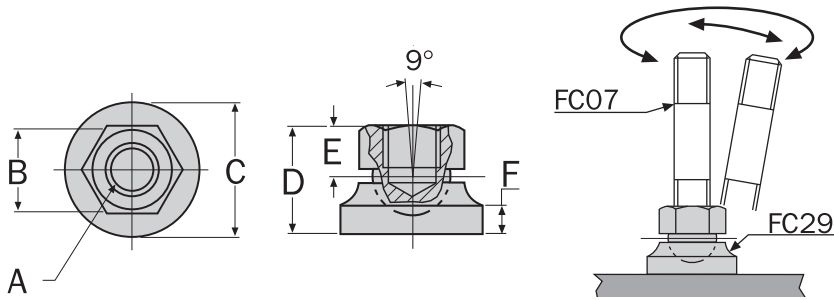

Product Number	Size A	Dimensions (mm)						Weight each	Order Code IND-425	Price/1 TB
		B	C	D	E	F				
FC290112	M12	19	35	24	11	7	80g	-2870D	1203.00	
FC290216	M16	24	40	29	13	8	150g	-2870G	1203.00	

FC40 - T-Slot Bolt

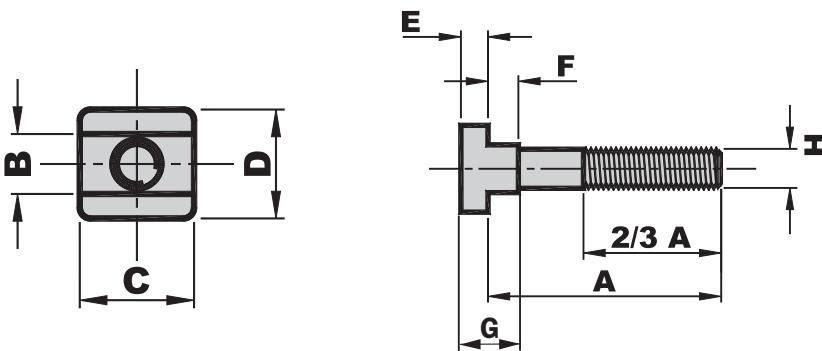

Material: Medium Carbon Steel.
Hardness: HRC 32 - 38.
Surface finish: Black Oxide.



Product Number	Dimensions (mm)								Weight each	Order Code IND-425	Price/1 TB
	A	B	C	D	E	F	G	H			
FC40-1250	50								54g	-2900D	328.00
FC40-1275	75								57g	-2900F	345.00
FC40-12100	100								110g	-2900H	357.00
FC40-12125	125	12	26	22	7	6	13	M12	125g	-2900K	384.00
FC40-12150	150								140g	-2900M	389.00
FC40-12175	175								170g	-2900P	400.00
FC40-12200	200								185g	-2900R	437.00
FC40-1650	50								130g	-2910D	410.00
FC40-1675	75								160g	-2910F	422.00
FC40-16100	100								200g	-2910H	434.00
FC40-16125	125	16	32	27	8	8	16	M16	230g	-2910K	466.00
FC40-16150	150								270g	-2910M	487.00
FC40-16175	175								305g	-2910P	542.00
FC40-16200	200								325g	-2910R	608.00
FC40-2075	75								290g	-2920F	542.00
FC40-20100	100								350g	-2920H	608.00
FC40-20125	125								400g	-2920K	629.00
FC40-20150	150	20	40	30	11	11	22	M20	455g	-2920M	684.00
FC40-20175	175								505g	-2920P	738.00
FC40-20200	200								560g	-2920R	827.00
FC40-24150	150	24	50	44	16	15	31	M24	775g	-2930M	1339.00
FC40-24200	200								925g	-2930R	1503.00

FC25 - Spherical Washer Set

2 piece washer set that compensates whenever a stud and clamping surface are not exactly perpendicular.

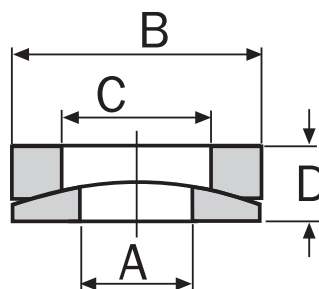

Material: Medium Carbon Steel.
Hardness: HRC 38.
Surface finish: Black Oxide.



Product Number	Dimensions (mm)				Weight each	Order Code IND-425	Price/1 TB
	A	B	C	D			
FC250112	13	26	15	7.5	20g	-2860D	546.00
FC250216	17	32	19	9.0	30g	-2860G	765.00
FC250320	21	40	23	12.0	50g	-2860L	931.00

INDEXA

SC01 - Support Spacer



Material: Medium Carbon Steel.
Hardness: HRC 40.
Surface finish: Black Oxide.

WORKSHOP EQUIPMENT

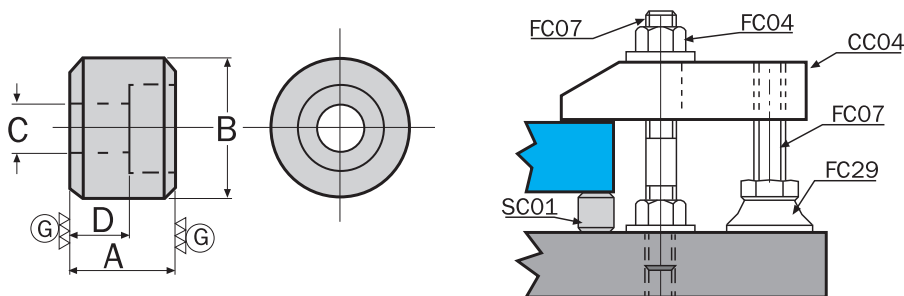

Product Number	Height x Diameter A (±0.01) x B	Dimensions (mm)		Weight each	Order Code	Price/1 TB
		C	D			
SC010112	30 x 40mm	M12	17	240g	-3005D	1417.00

SC04 - Location Collar

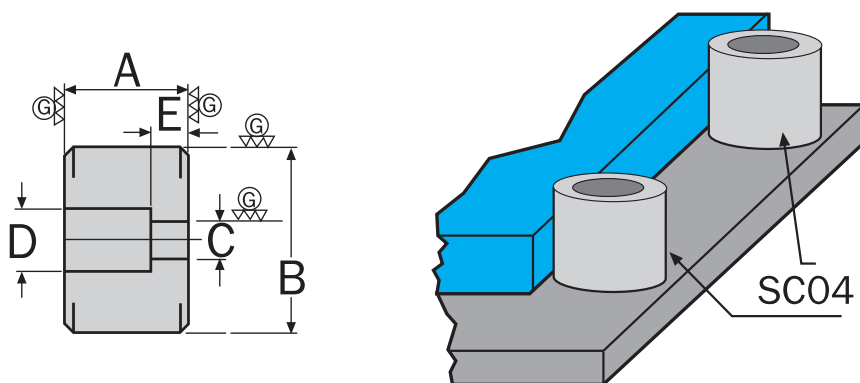

Material: Medium Carbon Steel.
Hardness: HRC 40.
Surface finish: Black Oxide.



Product Number	Height x Diameter A (±0.01) x B (±0.01)	Dimensions (mm)			Weight each	Order Code	Price/1 TB
		C	D	E			
SC040112	30 x 40mm	∅ 12	∅ 20	12	240g	-3020D	2290.00
SC040212	40 x 40mm	∅ 12	∅ 20	12	320g	-3020F	2290.00

SC10 - Extension Pillar

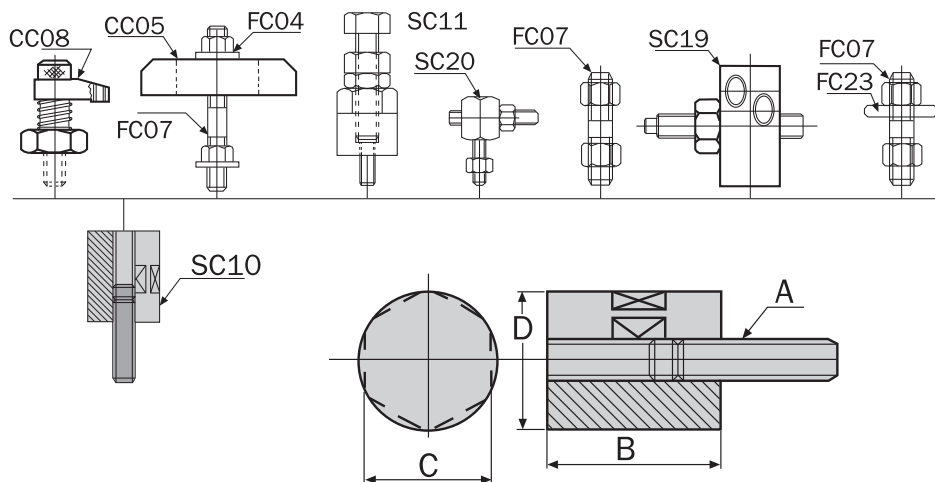

Material: Medium Carbon Steel.
Hardness: HRC 40.
Surface finish: Black Oxide.



Product Number	Height x Diameter A x B	Dimensions (mm)		Weight each	Order Code	Price/1 TB
		C	D			
SC100265	M12 x 65	36	40	540g	-3050F	2897.00
SC100450	M16 x 50	46	50	820g	-3050J	2951.00

PRODUCTS ARE ONLY AVAILABLE VIA YOUR DISTRIBUTOR

INDEXA SC11A - Screw Jack



Material: Medium Carbon Steel.
Hardness: HRC 40.
Surface finish: Black Oxide.

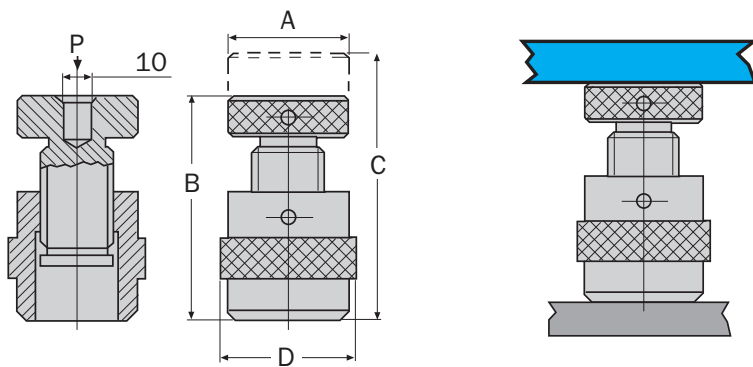

Product Number	Diameter x Height A x B (Min)	Dimensions (mm)		Holding Load (kN)	Weight each	Order Code IND-425	Price/1 TB
		C	D				
SC20032050	32 x 40mm	60	32	72	230g	-3057D	2460.00
SC20070140	65 x 100mm	150	70	135	274g	-3057P	8989.00

SU25 - Step Block

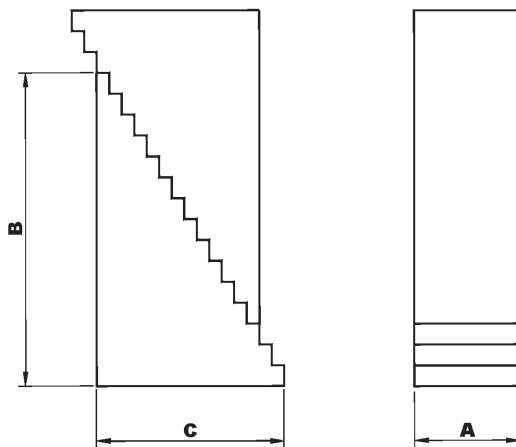

Material: Medium Carbon Steel.
Hardness: HRC 32 - 36.
Surface finish: Black Oxide.



Product Number	Supporting Height	Dimensions (mm)			Weight each	Order Code IND-425	Price/1 TB
		A	B	C			
SU252530	19 - 49		29	17	0.05kg	-3125E	464.00
SU252545	28 - 68	25	45	27	0.12kg	-3125H	493.00
SU252597	58 - 150		97.5	57	0.50kg	-3125L	1700.00
SU253259	38 - 90		59	35	0.24kg	-3132J	1494.00
SU253297	58 - 150	32	97.5	57	0.62kg	-3132L	1494.00
SU2532139	82 - 210		139	81	1.32kg	-3132P	2833.00

SEB - Shoulder Eye Bolt

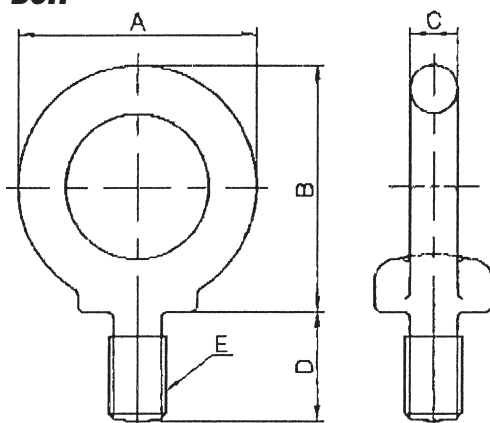

Product Number	Thread (E)	Dimensions (mm)				Load	Weight each	Order Code IND-425	Price/1 TB
		A	B	C	D				
SEB1017	M10	41	41.5	8	18	150kg	0.063kg	-3210S	137.00
SEB1220	M12	50	51	10	22	220kg	0.125kg	-3212S	192.00
SEB1525	M16	60	60	12.5	27	450kg	0.216kg	-3216S	328.00
SEB2030	M20	72	71	16	30	630kg	0.4kg	-3220S	367.00

INDEXA Horizontal & Vertical Index Unit Chucks



WORKSHOP EQUIPMENT

Ideal for indexing items to be machined in pre-set or manually set incremental angles. Indexing accuracy 25 seconds. Angular indexing through the graduation ring from 0 to 360 degrees in 1 degree increments. Basic indexing by means of a catch device permitting divisions of 2, 3, 4, 6, 8, 12 and 24 without disassembly. Fitted with standard three jaw self-centring scroll chuck with two sets of jaws, for inside and outside gripping.

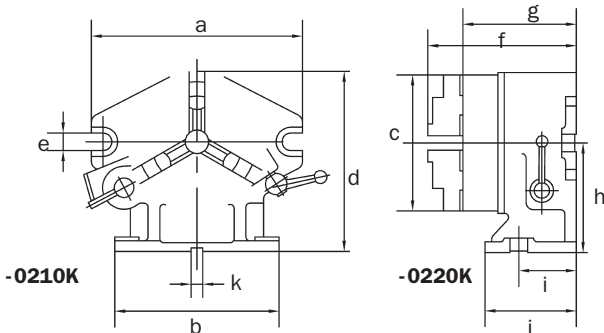

Chuck Diameter	Dimensions (mm)											Weight each	Order Code IND-437	Price/1 TB
	A	B	C	D	E	F	G	H	I	J	K			
167mm	260	220	167	220.00	18	197.5	155.5	130.00	70	130	16	17.8kg	-0210K	45089.00
220mm	310	255	210	255.25	18	214.0	171.5	149.25	80	150	16	94.0kg	-0220K	58350.00

Type SOPP Horizontal & Vertical Rotary Tables

With a disengageable worm gear which allows rapid indexing. One rotation of handle equals four degrees on collar. The table is made of high grade cast iron. Works as an indexing unit in the vertical position as well as a conventional rotary table for circular cutting, boring or angle setting, etc. Optional dividing plates are available separately.

Accuracy:

- Parallelism of clamping surface to base: 0.020mm
- Flatness of clamping surface: 0.015mm
- True running cylindrical centre bore: 0.020mm
- True running of tapered centre bore: 0.020mm
- Squareness of clamping surface to centre slot: 0.010mm

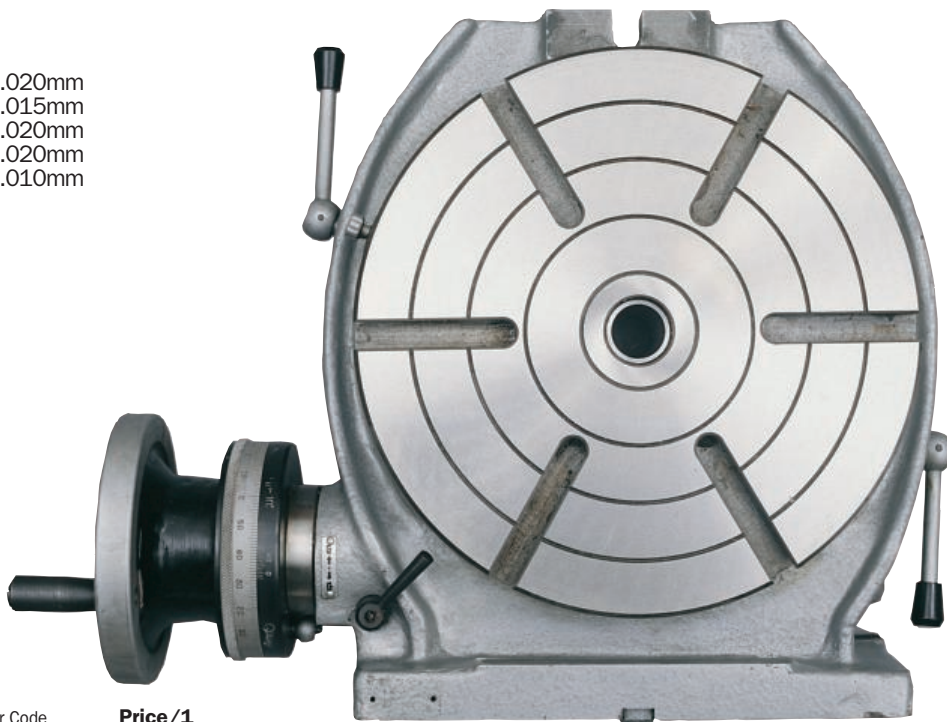
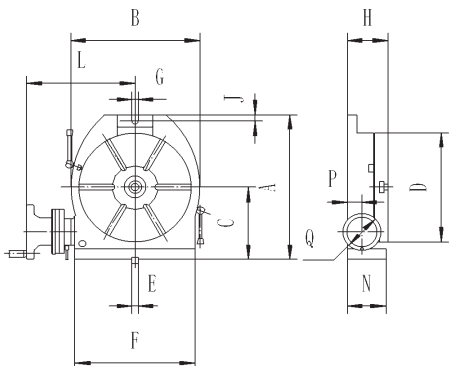

Optional Extras

Description	Order Code IND-437	Price/1 TB
Dividing Plate for INDEXA Rotary Tables	-1000K	7321.00

Rotary Tables

Diameter D	Max. Capacity C	Centre Hole M	Dimensions (mm)											No. of T-slots	Weight each	Order Code IND-437	Price/1 TB
			A	B	E	F	G	H	J	L	N	P	Q				
200mm	150	3 MT	285	236	14	208	14	100	15	211	99	48	125	4	42kg	-0500K	30385.00
250mm	170	3 MT	328	286	14	253	14	110	16	241	106	48	125	6	57kg	-0510K	35286.00
320mm	210	4 MT	410	360	18	320	18	120	16	273	118	48	140	6	92kg	-0520K	58350.00

PRODUCTS ARE ONLY AVAILABLE VIA YOUR DISTRIBUTOR

GROUP 440 CHUCKS

WORKSHOP EQUIPMENT

KENNEDY *Clamping Keyless Drill Chuck*

Allows quick tool change, while maintaining high precision and high concentricity. Fully hardened jaws, sleeve and retaining ring for durability and wear resistance. Self-tightening.



Capacity (mm)	Mount	Maximum Diameter	Weight each	Order Code KEN-440	Price/1 TB
4.0	1JT	28.0	150g	-3010K	11693.00
8.0	1JT	38.0	440g	-3110K	11700.00
10.0	2JT	43.0	720g	-3220K	10382.00
13.0	2JT	50.0	1000g	-3320K	12742.00
13.0	6JT	50.0	1000g	-3340K	12742.00
16.0	6JT	55.0	1200g	-3440K	14789.00

Clamping Industrial Keyless Drill Chuck

Fully hardened and ground working parts. The jaws are centre ground for alignment concentricity. Robustly designed for durability and wear resistance in the most arduous of industrial applications on stationary drilling machines. Unsuitable for reversing drills.



Capacity (mm)	Mount	Maximum Diameter	Weight each	Order Code KEN-440	Price/1 TB
10.0	DIN-B12	42.5	670g	-5220K	5851.00
13.0	6JT	46.0	920g	-4240K	8278.00
13.0	1/2" - 20F	46.0	660g	-4280K	5010.00
16.0	6JT	51.0	1100g	-4340K	9678.00
16.0	DIN-B16	51.0	1090g	-5300K	8280.00

KOBE *Drill Chuck*

Fully hardened and ground for durability and wear resistance. Suitable for use with portable power tools.



Capacity (mm)	Mount	Order Code KBE-440	Price/1 TB
1.5 - 13.0	3/8" - 24F	-2020B	983.00
1.5 - 13.0	1/2" - 20F	-2030C	575.00

Drill Chuck

For use with portable power tools. Female mount. Supplied with key. UNF keyed chuck, hardened and ground for durability and wear resistance. For use with reversible drills. Excellent value for money.



Capacity (mm)	Mount	Weight each	Order Code KBE-440	Price/1 TB
1.0 - 10.0	3/8" - 24F	135g	-1010A	328.00
1.5 - 13.0	3/8" - 24F	270g	-1020B	361.00
1.5 - 13.0	1/2" - 20F	270g	-1030C	361.00

KENNEDY *Standard Duty Industrial Keyed Drill Chuck*

Fully hardened and ground for durability and wear resistance. Suitable for use with portable power tools. Supplied with key.



Manufactured to DIN 6349.

*Primarily for use with hand operated machines

Capacity (mm)	Mounting	Maximum Diameter	Weight each	Order Code KEN-440	Price/1 TB
0.8 - 10.0	3/8" x 24F	34.0	240g	-2360K	1341.00
0.8 - 10.0*	1/2" x 20F	34.0	220g	-2380K	1406.00
1.5 - 13.0	3/8" x 24F	42.7	390g	-2460K	1744.00
1.5 - 13.0	1/2" x 20F	42.7	390g	-2480K	1744.00

Heavy Duty Industrial Keyed Drill Chuck

Fully hardened and ground working parts. The jaws are centre ground for alignment and concentricity. Key holes and teeth are fully hardened for durability and wear resistance. To correctly tighten your keyed drill chuck use all key holes in turn to guarantee even pressure and maximum grip. Suitable for use on machine tools and all types of industrial power tools. Supplied with key. Manufactured to DIN 6349.



* Primarily for use with hand operated machines.
† Not suitable for reversing drills.

Capacity (mm)	Mounting	Maximum Diameter	Weight each	Order Code KEN-440	Price/1 TB
0.5 - 6.5	1JT	30.0	140g	-1110K	2372.00
0.5 - 6.5	3/8"-24F †	30.0	140g	-1160K	2431.00
1.0 - 10.0	2JT	42.7	430g	-1320K	2670.00
0.8 - 10.0	DIN-B12	42.7	400g	-5020K	2688.00
1.0 - 13.0	6JT	52.0	730g	-1440K	3680.00
1.0 - 13.0	33JT	52.0	740g	-1450K	3236.00
1.5 - 13.0	DIN-B12	52.7	750g	-5060K	2851.00
1.0 - 13.0	DIN-B16	52.7	780g	-5080K	3511.00
1.0 - 16.0	3JT	56.5	970g	-1530K	4714.00
1.5 - 13.0	1/2"-20F	42.8	270g	-4640K	1051.00
1.5 - 13.0	3/8"-24F †	42.5	420g	-1460K	3302.00
1.5 - 13.0	1/2"-20F †	46.0	530g	-1480K	3302.00
3.0 - 16.0	DIN-B16	56.5	890g	-5100K	4050.00
3.0 - 16.0*	1/2"-20F †	50.0	610g	-1580K	3690.00
5.0 - 20.0	3JT	65.0	1300g	-1630K	6351.00

Keyless Drill Chuck

Designed for use on cordless screwdrivers, cordless and corded drills. Unique gripping mechanism engages automatically when tightened. Fully hardened and ground jaws protect against work surface abrasion. Through drilled for use on reversible drills.



Capacity (mm)	Mount	Order Code KEN-440	Price/1 TB
1.5 - 13	1/2" - 20F	-4740K	2372.00
1.5 - 13	3/8" - 24F	-4760K	2372.00

KENNEDY *Chuck Keys*
QUALITY INDUSTRIAL TOOLING

Suitable for use with all industrial keyed chucks (including Rohm* and Jacobs).

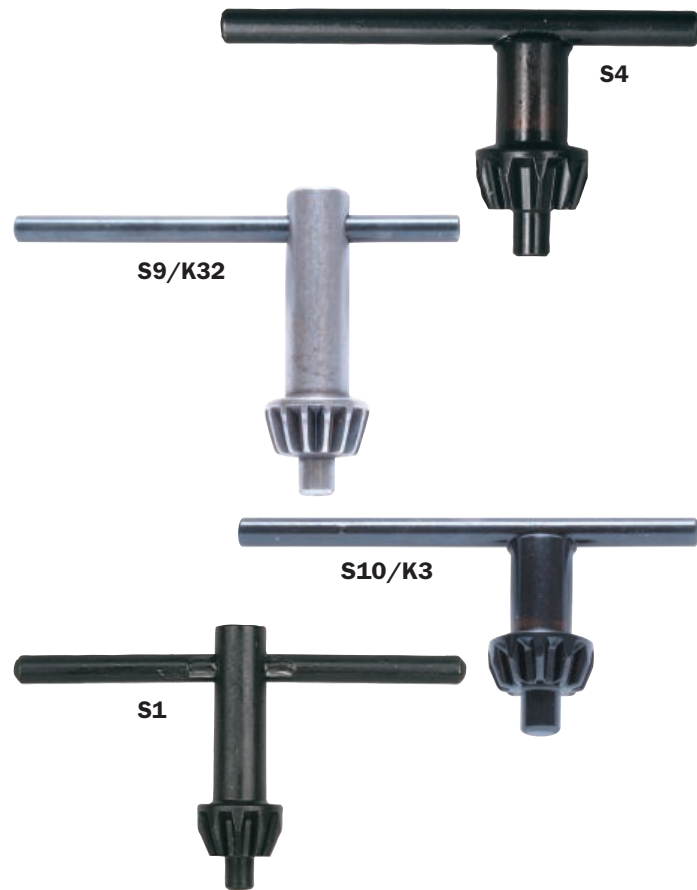

Ref No.	For Use With Chuck Number	Jacobs Equivalent	Weight each	Order Code KEN-441	Price/1 TB
S1	440-106/111/116 & 226 *4, 6, 6M & 8M	-	20g	-0020K	113.00
S2	440-132/136/138/139/146/148/236/237/238/246/247/248 & all Supercraft Chucks *10S, 10, 10M, 13S & 13M	K8/10	50g	-0040K	133.00
S3	440-142/144/145/153 & 158	-	70g	-0060K	305.00
S4	440-163 *20 & 26	-	160g	-0080K	444.00
S7	1 Series	K1	20g	-0140K	167.00
S8	31 Series & 8½N	K30S	50g	-0160K	217.00
S9	32 & 33 Series, 11N	K32	60g	-0180K	240.00
S13	36 Series, 16, 18N	K4	150g	-0260K	818.00
S14	¼", ⅝", ⅜" Multicraft	KG	20g	-0280K	274.00
S18	7 Series	K7	30g	-0360K	416.00
S10	3 & 6 Series, 14N	K3	90g	-0400K	416.00
K2	2 Series	K2	40g	-1020K	218.00

KOBE *Chuck Keys*



Model Number	To Suit Drill Chuck	Weight each	Order Code KBE-441	Price/1 TB
10043KG	10mm	40g	-2010A	94.00
10038KK	13mm	50g	-2020B	105.00



KENNEDY *Industrial Drill Chuck Arbors*
QUALITY INDUSTRIAL TOOLING

Precision machined, fully hardened and ground to give maximum surface contact.

Morse Taper Drive to Jacobs Taper



Description	Overall Length	Weight each	Order Code KEN-442	Price/1 TB
No.1 MT x 1JT	90mm	70g	-9110K	240.00
No.1 MT x 2JT	95mm	80g	-9120K	240.00
No.1 MT x 6JT	96mm	100g	-9160K	255.00
No.1 MT x 33JT	95mm	90g	-9190K	442.00
No.2 MT x 1JT	100mm	150g	-9210K	227.00
No.2 MT x 2JT	105mm	160g	-9220K	285.00
No.2 MT x 3JT	115mm	220g	-9230K	263.00
No.2 MT x 6JT	110mm	180g	-9260K	316.00
No.2 MT x 33JT	110mm	180g	-9290K	242.00
No.3 MT x 1JT	120mm	310g	-9310K	595.00
No.3 MT x 2JT	125mm	330g	-9320K	329.00
No.3 MT x 3JT	135mm	380g	-9330K	336.00
No.3 MT x 4JT	145mm	520g	-9340K	357.00
No.3 MT x 5JT	150mm	680g	-9350K	1906.00
No.3 MT x 6JT	130mm	340g	-9360K	357.00
No.3 MT x 33JT	125mm	340g	-9390K	457.00
No.4 MT x 2JT	135mm	700g	-9420K	818.00
No.4 MT x 3JT	160mm	730g	-9430K	818.00
No.4 MT x 4JT	170mm	860g	-9440K	818.00
No.4 MT x 5JT	175mm	1000g	-9450K	1906.00
No.4 MT x 6JT	155mm	690g	-9460K	818.00
No.4 MT x 33JT	155mm	680g	-9490K	818.00
No.5 MT x 3JT	190mm	1700g	-9530K	2023.00
No.5 MT x 5JT	210mm	1900g	-9550K	2023.00

Bridgeport Drive to Jacobs Taper

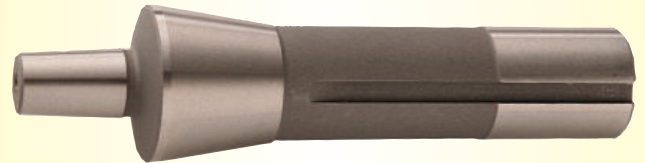

Description	Overall Length	Weight each	Order Code KEN-442	Price/1 TB
R8 x 1JT	130mm	420g	-9610K	2201.00
R8 x 2JT	135mm	440g	-9620K	2201.00
R8 x 3JT	145mm	510g	-9630K	2201.00
R8 x 6JT	135mm	450g	-9660K	1834.00
R8 x 33JT	135mm	460g	-9690K	1570.00

Morse Taper Drive to Threaded



Description	Overall Length	Weight each	Order Code KEN-442	Price/1 TB
No.1 MT ½ x 20	92mm	100g	-1120K	1507.00
No.1 MT ⅜ x 24	95mm	80g	-1380K	1507.00
No.2 MT ½ x 20	105mm	170g	-2120K	1789.00
No.2 MT ⅜ x 24	105mm	170g	-2380K	1789.00
No.2 MT ⅝ x 16	105mm	180g	-2580K	1789.00
No.3 MT ½ x 20	125mm	360g	-3120K	1977.00
No.3 MT ⅝ x 16	125mm	370g	-3580K	1977.00

KD Type - Morse Taper Shank to Din Taper Arbors

Fully hardened and ground Morse Taper to DIN 228. Chuck taper to DIN 238.



Morse Taper	Chuck Taper	Overall Length	Order Code KEN-442	Price/1 TB
No.2 MT	B12	106.5mm	-5220K	205.00
No.2 MT	B16	111.5mm	-5260K	205.00
No.3 MT	B12	125.0mm	-5320K	286.00
No.3 MT	B16	134.0mm	-5360K	286.00
No.4 MT	B16	159.0mm	-5420K	476.00
No.4 MT	B22	176.0mm	-5460K	476.00



Selection - Clamp Type

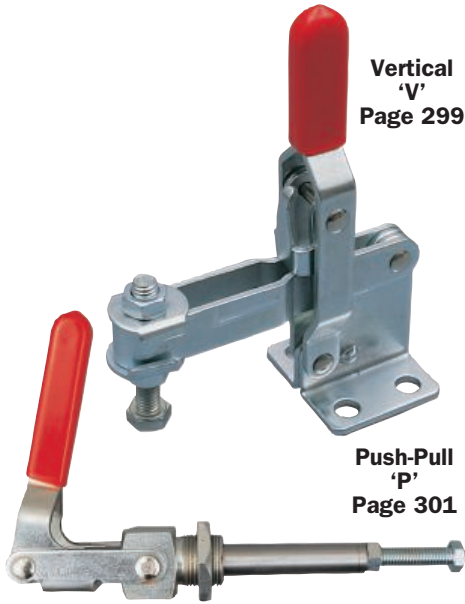

Vertical 'V'
Page 299

Push-Pull 'P'
Page 301

Vertical
For general application in automotive and other heavy industries where trouble free life and robust construction are required. Force applied downward, 90° to bar.

Horizontal
For general application in areas where a lower profile and unobstructiveness are required. Force applied downward, 90° to bar.

Push-Pull
Clamps lock in extended and retracted positions. Force applied in line with spindle (straight line action).

Latch
Suitable for applications such as sealing chamber doors, lids of mould closures. Latch bolts are threaded to allow easy adjustment.

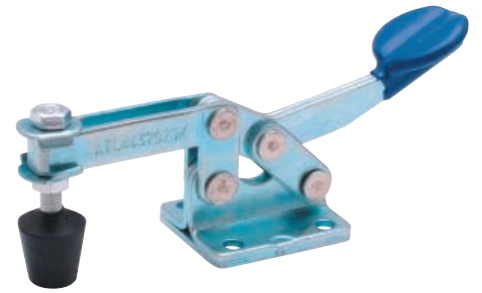

Horizontal 'H'
Page 300

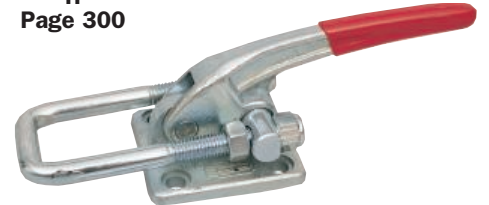

Latch 'L'
Page 300

Selection by Product Number

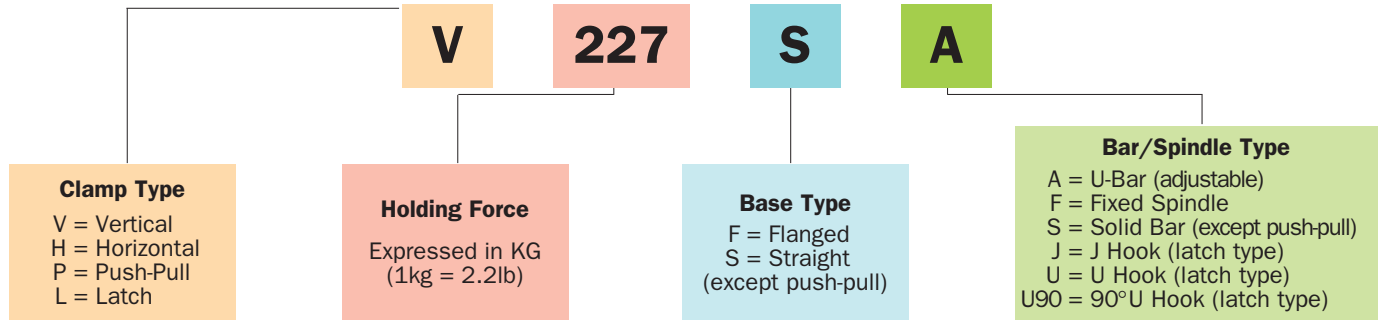

Flanged 'F'

Selection - Base Type

Flanged
Suitable for bolting or welding the clamp on to a flat surface.

Straight
Suitable for mounting on to an outside face or edge of workpiece.



Straight 'S'

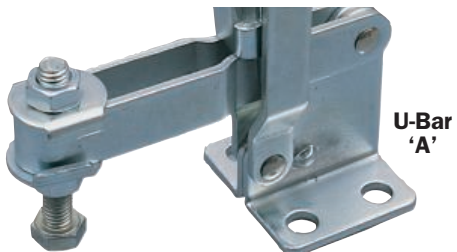

U-Bar 'A'

Selection - Bar/Spindle Type

U-Bar
Clamping spindle can be adjusted along length of bar.

Fixed Spindle
Clamping spindle is in a fixed position on the arm.

Solid Bar
Clamping spindle and retainer are supplied loose to allow the arm to be cut to length and welded in desired position.

Threaded Spindle
Used for push-pull type of clamp.

U-Hook
Threaded for easy adjustment.

J-Hook
Locks directly regardless of angle of hook.

90° U Hook
Locks at 90° to clamp.



Threaded Spindle 'handle position'



U-Hook 'U'



90° U-Hook 'U90'



J-Hook 'J'

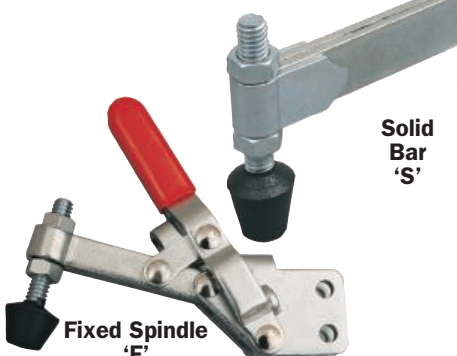

Fixed Spindle 'F'



INDEXA Vertical Industrial Toggle Clamp

Designed to improve performance in fabrication and engineering clamping applications. The rapid clamping/unclamping made possible by the use of toggle clamps can greatly reduce machine/operator 'down-time' during all stages of production.

Clamping Capacity - the forces stated are the maximum loads that can be applied without causing permanent deformation. Due to leverage ratios, the holding capacity will be greatest at the point on the bar nearest to the handle of the clamp and forces stated have been achieved at this point.

Vertical Clamp Dimensions (mm)

Holding Capacity	A ₁ Flanged Base	A ₂ Straight Base	B ₁ Adj. Bar	B ₂ Fixed Bar	B ₃ Solid Bar	C Flanged Base	D	E	F Flanged Base	W
50kg	75.0	83.8	24.5	-	-	19.0	25.4	15.9	33.3	5.2
90kg	95.2	107.1	33.2	33.2	-	23.0	25.4	12.7	39.7	6.4
150kg	139.0	160.0	63.0	-	-	38.0	43.0	33.0	50.0	11.0
227kg	139.7	154.0	71.4	-	57.2	31.8	34.9	31.8	46.0	8.3
300kg	285.0	330.0	120.0	-	-	50.0	60.0	30.0	77.0	13.5
450kg	225.4	257.5	125.4	-	-	50.8	50.8	31.8	64.2	13.5
550kg	304.8	352.4	153.0	-	153.0	82.6	76.2	50.8	95.2	16.7

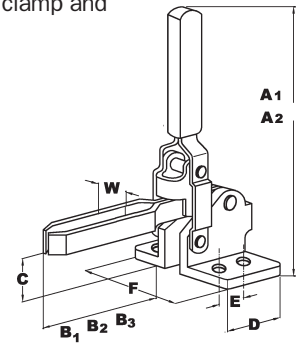

'U' Bar (Adjustable) Type

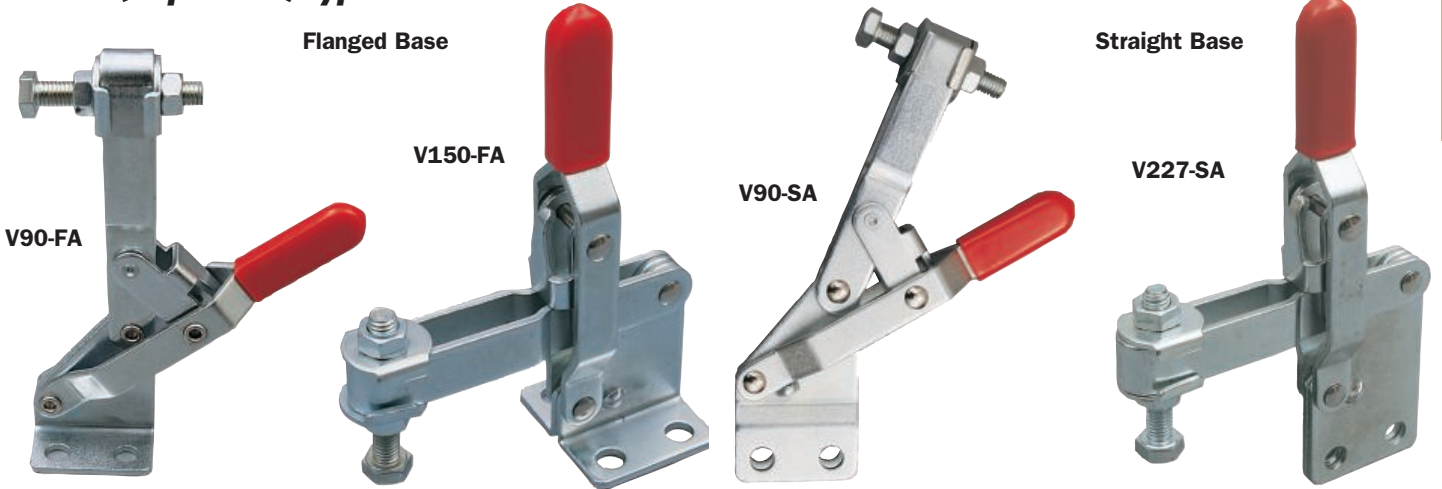

Product Number	Holding Capacity	Movement Handle	Bar	Base Type	Supplied With	Weight each	Order Code IND-443	Price/1 TB
V50-FA	50kg	56°	100°	Flanged	Tipped Spindle (No.10) and Flanged Washer	60g	-1020K	615.00
V90-FA	90kg	60°	100°		Spindle (1/4") and Flanged Washer	125g	-1220K	908.00
V150-FA	150kg	45°	94°		Hex Head Spindle (M8) and Bolt Retainer	320g	-1320K	669.00
V227-FA	227kg	60°	100°		Tipped Spindle (5/16") and Flanged Washer	355g	-1420K	721.00
V300-FA	300kg	67°	140°		Hex Head Spindle (M10)	1250g	-1620K	1252.00
V450-FA	450kg	70°	135°		Hex Head Spindle (1/2") and Flanged Washer	1140g	-1720K	1464.00
V550-FA	550kg	60°	140°	Straight	Hex Head Spindle (5/8") and Flanged Washer	2540g	-1920K	2234.00
V340-FA	340kg	58°	105°		Tipped Spindle (3/8") and Flanged Washer	635g	-1590K	1252.00
V90-SA	90kg	60°	100°		Spindle (1/4") and Flanged Washer	170g	-1270K	828.00
V150-SA	150kg	45°	94°		Hex Head Spindle (M8) and Bolt Retainer	320g	-1370K	669.00
V227-SA	227kg	60°	100°		Tipped Spindle (5/16") and Flanged Washer	355g	-1470K	615.00
V450-SA	450kg	70°	135°		Hex Head Spindle (5/8") and Flanged Washer	1250g	-1770K	1330.00

Fixed Spindle & Solid Bar Type

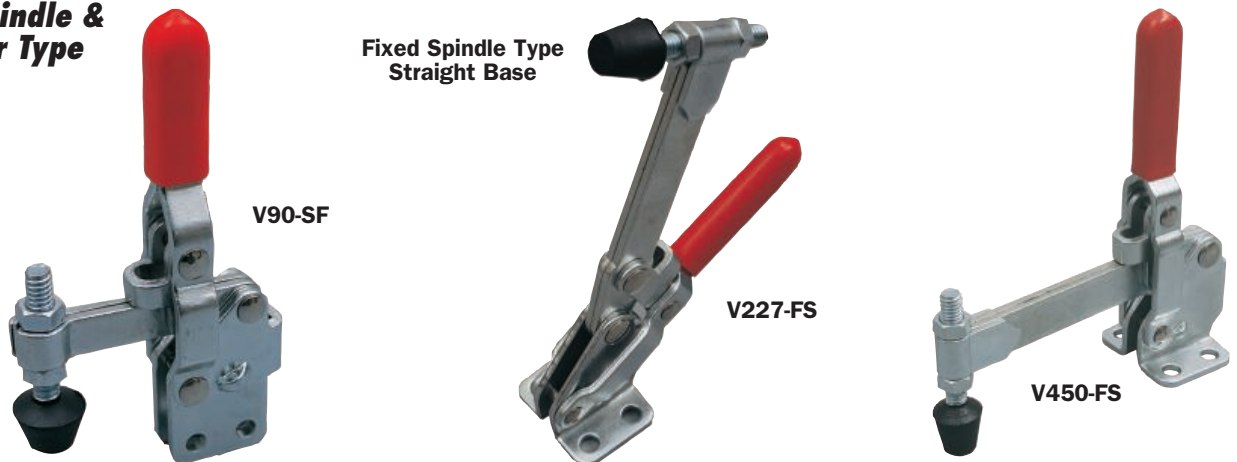

Product Number	Holding Capacity	Movement Handle	Bar	Base Type	Supplied With	Weight each	Order Code IND-443	Price/1 TB
V100-FF	90kg	60°	100°	Flanged	Fixed Spindle (1/4")	170g	-1120K	669.00
V90-SF	90kg	60°	100°	Straight	Fixed Spindle (1/4")	170g	-1170K	669.00
V227-FS	227kg	60°	100°	Flanged	Solid Bar Hex Head (5/16") and Bolt Retainer*	340g	-1520K	828.00
V450-FS	450kg	70°	135°		Solid Bar Hex Head Spindle (1/2") and Bolt Retainer*	1250g	-1820K	1464.00
V550-FS	550kg	60°	140°		Solid Bar Hex Head Spindle (5/8") and Bolt Retainer*	2540g	-1940K	2234.00
V227-SS	227kg	60°	100°	Straight	Solid Bar Tipped Spindle (5/16") and Bolt Retainer*	340g	-1570K	828.00
V450-SS	450kg	70°	135°		Solid Bar Hex Head Spindle (5/8") and Bolt Retainer*	1250g	-1870K	1438.00

PRODUCTS ARE ONLY AVAILABLE VIA YOUR DISTRIBUTOR

GROUP 443 TOGGLE CLAMPS

INDEXA Horizontal Industrial Toggle Clamp



With a low profile design suitable for use in applications requiring increased access to the actual workpiece. Available in eight sizes for general application in areas where a lower profile is required. Force applied downwards 90° to bar.

WORKSHOP EQUIPMENT

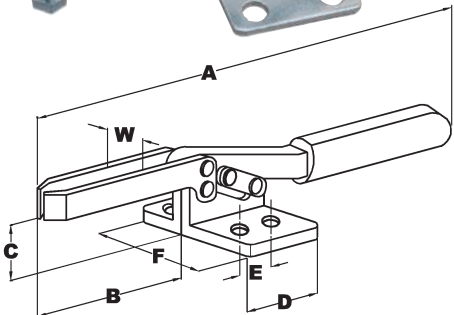
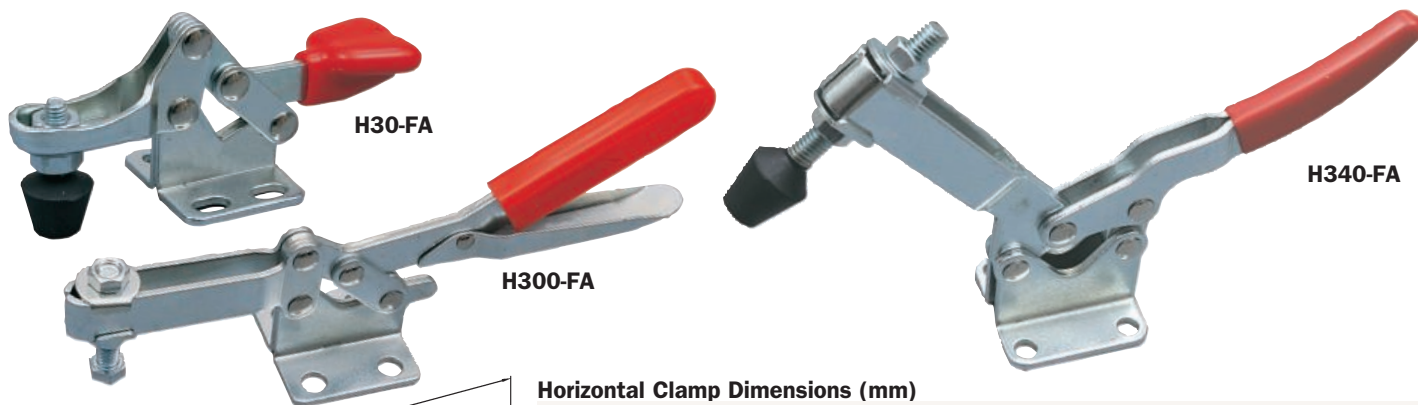

Horizontal Clamp Dimensions (mm)

Holding Capacity	A	B	C	D	E	F	W
30kg	76.5	28.0	12.5	24.0	11.5	28.5	8.5
90kg	138.0	55.0	25.4	37.0	25.4	36.0	7.4
227kg	168.0	70.0	34.9	38.0	25.4	35.0	8.3
300kg	270.0	85.0	36.5	58.0	34.0	60.0	11.0
340kg	262.0	107.5	46.9	57.1	41.3	57.2	11.0
400kg	240.0	60.0	54.0	70.0	42.0	50.0	12.6
500kg	270.0	91.2	38.0	58.0	37.0	70.0	11.0
636kg	272.0	76.2	51.0	90.0		48.0	12.7

Product Number	Holding Capacity	Movement Handle	Bar	Base Type	Supplied with	Weight each	Order Code IND-443	Price/1 TB
H65-FA	75kg	76°	94°	Flanged	Hex Head Spindle (M5) Moulded PVC Handles	100g	-1960K	721.00
H86-FA	150kg	76°	94°		Hex Head Spindle (M6) Moulded PVC Handles	230g	-1970K	828.00
H217-FA	250kg	76°	94°		Hex Head Spindle (M8) Moulded PVC Handles	430g	-1980K	934.00
H30-FA	30kg	88°	80°		Tipped Spindle (M4)	40g	-2020K	615.00
H90-FA	90kg	60°	85°		Tipped Spindle (1/4") and Flanged Washer	130g	-2120K	828.00
H227-FA	227kg	65°	90°		Tipped Spindle (5/16") and Flanged Washer	255g	-2220K	802.00
H300-FA	300kg	85°	80°		Hexagon Head Spindle (3/8") and Flanged Washer	490g	-2320K	1226.00
H340-FA	340kg	50°	85°		Tipped Spindle (3/8") and Flanged Washer	640g	-2420K	1439.00
H400-FA	400kg	85°	84°	Tipped Spindle (3/8") and Flanged Washer	600g	-2520K	1657.00	
H500-FA	500kg	85°	65°	Hexagon Head Spindle (M10) and Flanged Washer	450g	-2620K	1657.00	
H636-FA	636kg	94°	91°	Hexagon Head Spindle (1/2") and Flanged Washer**	1220g	-2720K	1864.00	

**Single mounting centre hole 1.3mm diameter for 'Tee' bolt mounting

Latch Type Toggle Clamp

Suitable for sealing chamber doors or mould closures. The latched bolts are threaded to allow easy adjustment and provide positive connection with latch plate.

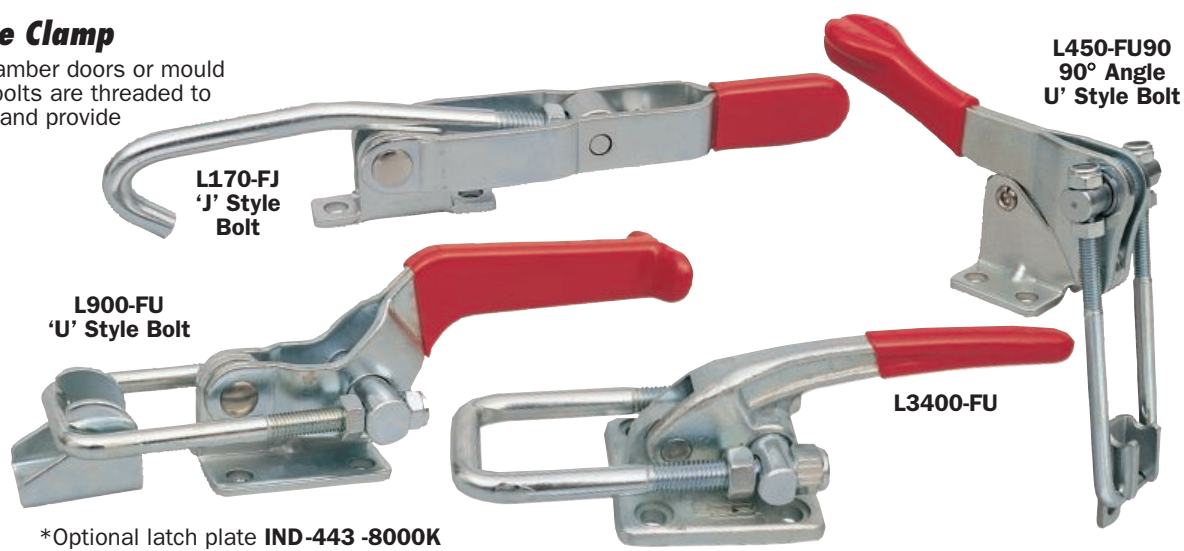

*Optional latch plate IND-443 -8000K

Product Number	Holding Capacity	Drawing Movement	Drawing Adjust	Base Type	Description	Weight each	Order Code IND-443	Price/1 TB
L164-FU	164kg	30mm	9.9mm	Flanged	U-Style Bolt	80g	-4070K	618.00
L318-FU	318kg	45mm	9.6mm		U-Style Bolt	225g	-4010K	725.00
L900-FU	900kg	80mm	23.8mm		U-Style Bolt	680g	-4130K	1043.00
L1818-FU	1818kg	88.9mm	19mm		U-Style Bolt*	1260g	-4170K	2741.00
L3400-FU	3400kg	55.6mm	28.6mm	U-Style Bolt*	1480g	-4210K	3564.00	
L170-FJ	170kg	100mm	6.5mm	Flanged	J-Style Bolt	270g	-4030K	699.00
L170-FJ	170kg	105mm	35mm		J-Style Bolt	255g	-4050K	618.00
L340-FJ	340kg	140mm	40mm		J-Style Bolt	340g	-4190K	1044.00
L225-FU90	225kg	25mm	15mm	Flanged	90° Angle U-Style Bolt	113g	-4090K	618.00
L450-FU90	450kg	65mm	33mm		90° Angle U-Style Bolt	250g	-4110K	831.00
L900-FU90	900kg	45mm	40mm		90° Angle U-Style Bolt	700g	-4150K	1204.00



INDEXA *Push Pull Industrial Toggle Clamp*

The straight line action which gives these plunger-style clamps extremely high loading capacities whilst maintaining compactness. These clamps also lock in the open position which allows a 'pull' to be exerted (for instance, in use with foam moulds). All models have tapped spindles for use with adjustable spindles.

Base Mounted Type (Flanged)

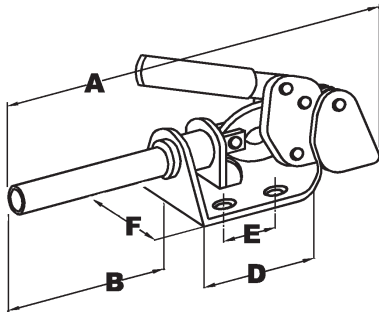
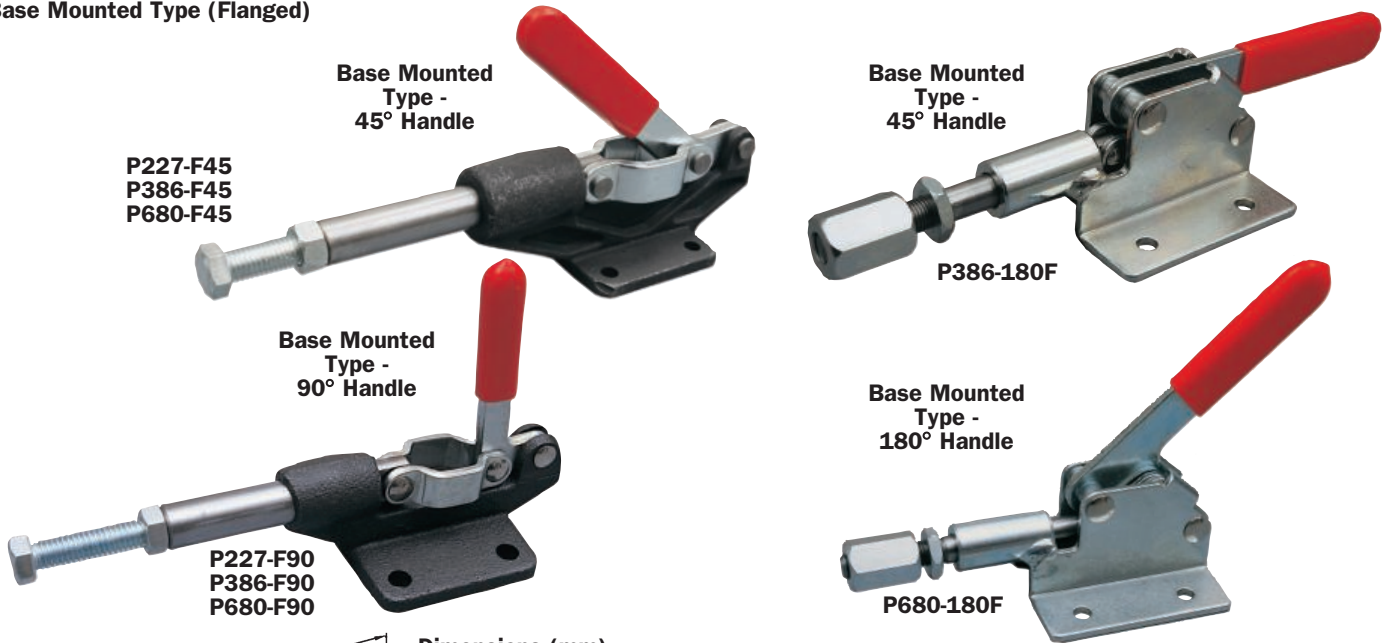

Dimensions (mm)

Holding Capacity	A – Excluding Handle	B	C	D	E	F
45kg	72.2	38.9	9.5	33.3	15.0	27.0
50kg	71.9	16.9	13.0	49.0	24.0	42.0
136kg	138.0	47.0	24.6	48.0	35.0	56.0
160kg	146.0	76.0	15.5	70.0	40.0	72.0
200kg	124.5	41.5	14.0	48.0	40.0	50.0
227kg	125.4	52.4	19.0	52.4	35.0	57.2
295kg	204.0	112.0	17.7	92.0	60.0	83.0
386kg	158.8	81.0	23.8	58.8	41.4	57.2
680kg	238.2	120.8	35.0	73.2	50.8	71.4
1136kg	178.6	50.8	12.5	127.8	34.9	56.2
1136kg	178.6	50.8	12.5	127.8	41.3 (6 holes)	56.2
1600kg	310.0	87.0	47.0	227.0	80.0	107.0

Product Number	Holding Capacity	Spindle Thread	Handle Movement	Handle Position	Base Type	Supplied With	Weight each	Order Code IND-443	Price/1 TB
P45-F45	45kg	1/4" UNC x 12 Deep	190°			Nylon Spindle	50g	-3030K	616.00
P136-F45	136kg	M8	180°			Hexagon Head Spindle	300g	-3060K	670.00
P200-F45	180kg	M8 x 1.25	144.5°			Hexagon Head Spindle	345g	-3090K	829.00
P180-FA	180kg	M8 x 1.25	145°	45°	Flanged	Hexagon Head Spindle	35g	-3100K	935.00
P227-F45	227kg	M8	180°	Extended	Flanged	Hexagon Head Spindle	340g	-3120K	829.00
P386-F45	386kg	M10	180°			Hexagon Head Spindle	580g	-3180K	1306.00
P680-F45	680kg	M12	180°			Hexagon Head Spindle	1480g	-3240K	1571.00
P1136-F45	1136kg	M10	180°			Hexagon Head Spindle	935g	-3300K	1465.00
P227-F90	227kg	M8 x 30 Deep	180°	90°	Flanged	Hexagon Head Spindle	340g	-3150K	829.00
P386-F90	386kg	M10 x 40 Deep	180°	Extended	Flanged	Hexagon Head Spindle	580g	-3210K	1200.00
P680-F90	680kg	M12 x 50 Deep	180°			Hexagon Head Spindle	1480g	-3270K	2261.00
P50-180F	50kg	M5	66°	180°	Flanged	Hexagon Head Spindle	100g	-3700K	616.00
P386-180F	160kg	M10	45°	Extended	Flanged	Hexagon Head Spindle	454g	-3730K	935.00
P680-180F	295kg	1/2" UNC	45°			Hexagon Head Spindle	1270g	-3760K	1334.00

Collar Mounted Type (Threaded)

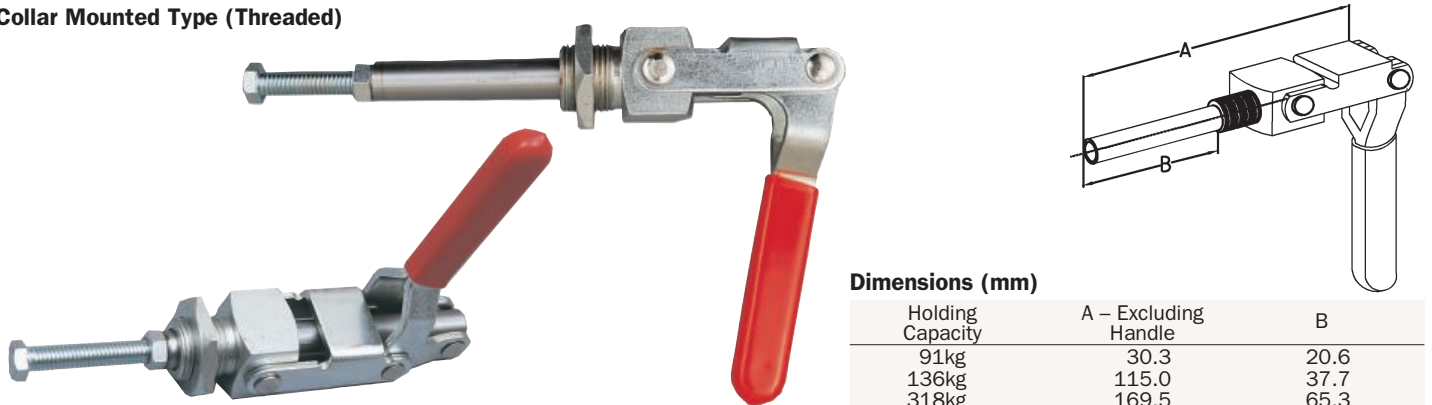

Dimensions (mm)

Holding Capacity	A – Excluding Handle	B
91kg	30.3	20.6
136kg	115.0	37.7
318kg	169.5	65.3

Product Number	Holding Capacity	Spindle Thread	Collar Thread	Handle Movement	Base Type	Supplied with	Weight each	Order Code IND-443	Price/1 TB
P91-FT	91kg	1/4" UNC	M16	180°		Nylon Spindle	113g	-3530K	723.00
P136-FT	136kg	5/16" UNC	M20	180°	Flanged	Hexagon Head Spindle	270g	-3560K	829.00
P318-FT	318kg	3/8" UNC	M27	180°		Hexagon Head Spindle	690g	-3590K	1439.00

PRODUCTS ARE ONLY AVAILABLE VIA YOUR DISTRIBUTOR

GROUP 443 TOGGLE CLAMPS

ATLAS WORKHOLDERS

Vertical Industrial Toggle Clamp

Designed to improve performance in fabrication and engineering clamping applications. The rapid clamping/unclamping made possible by the use of toggle clamps can greatly reduce machine/operator 'down-time' during all stages of production.



WORKSHOP EQUIPMENT



AV200-FA

'U' Bar (Adjustable) Type with Flanged Base

AV217-FA

AV50-FA

'U' Bar (Adjustable) Type with Side Facing Flanged Base

AV90-FA

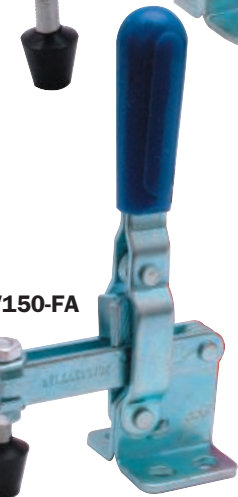

AV150-FA



Group 732



AV450-FA

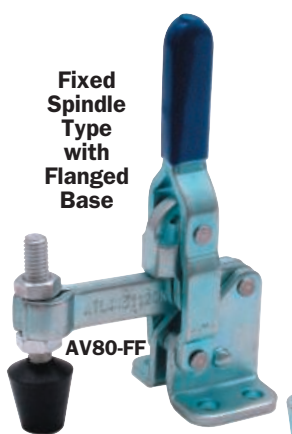

Fixed Spindle Type with Flanged Base

AV80-FF

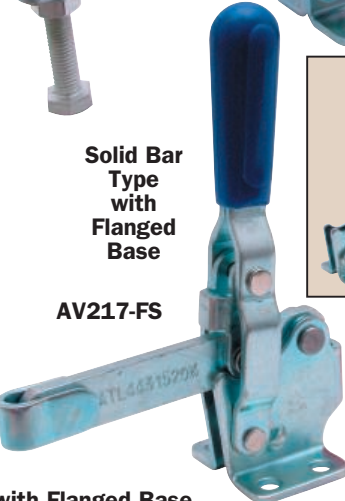

Solid Bar Type with Flanged Base

AV217-FS



Dimensions

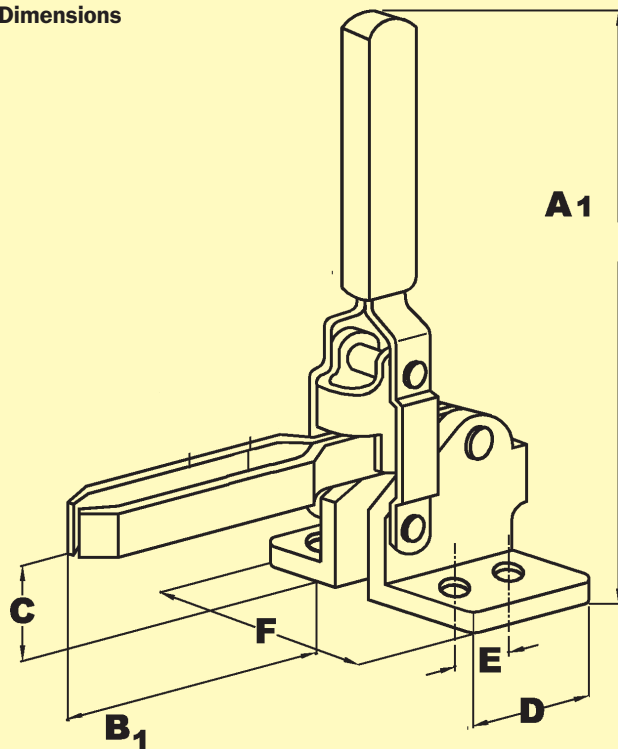

'U' Bar (Adjustable) Type with Flanged Base

Product Number	A ₁ Flanged Base	B ₁ Flanged Base	C Flanged Base	D	E	F Flanged Base
AV50-FA	75.0	24.5	19.0	25.4	15.9	39.7
AV90-FA	93.0	39.0	23.0	29.0	14.0	28.0
AV150-FA	143.0	44.0	31.0	19.0	12.7	42.0
AV200-FA	139.0	63.0	38.0	43.0	24.0	50.0
AV217-FA	139.7	71.4	31.8	34.9	19.0	46.0
AV450-FA	272.0	125.0	62.0	70.0	40.0	70.0

Fixed Spindle Type with Flanged Base

Product Number	A ₁ Flanged Base	B ₁ Flanged Base	C Flanged Base	D	E	F Flanged Base
AV80-FF	100.0	27.0	23.8	25.4	12.7	39.7
AV217-FS	139.7	57.2	31.8	34.9	19.0	46.0

'U' Bar (Adjustable) Type with Flanged Base

Product Number	Holding Capacity	Movement Handle	Movement Bar	Base Type	Supplied With	Weight each	Order Code ATL-443	Price/1 TB
AV50-FA	50kg	56°	100°	Flanged	Tipped Spindle (M5) and Flanged Washers	60g	-1020K	328.00
AV90-FA**	90kg	60°	100°		Spindle (M6) and Bolt Retainer	115g	-1220K	651.00
AV150-FA	150kg	70°	108°		Hex Head Spindle (M6) Moulded PVC Handle	230g	-1970K	626.00
AV200-FA	200kg	45°	94°		Hex Head Spindle (M8) and Flanged Washers	370g	-1320K	747.00
AV217-FA	217kg	60°	100°		Tipped Spindle (M8) and Flanged Washers	310g	-1420K	604.00
AV450-FA	450kg	70°	135°		Hex Head Spindle (M12) and Flanged Washers	1220g	-1720K	1297.00

** Model AV90-FA has Side Flange - All other FA models listed have Flat Flanges

Fixed Spindle Type with Flanged Base

Product Number	Holding Capacity	Movement Handle	Movement Bar	Base Type	Supplied With	Weight each	Order Code ATL-443	Price/1 TB
AV80-FF	90kg	60°	100°	Flanged	Fixed Spindle (M8)	170g	-1120K	649.00
AV217-FS	217kg	60°	100°		Solid Bar and Bolt Retainer (M8)*	310g	-1520K	670.00

*Please note that the bolt retainer supplied needs to be welded in to position by the user

ATLAS WORKHOLDERS *Horizontal Industrial Toggle Clamps*

With a low profile design suitable for use in applications requiring increased access to the actual workpiece. Available in eight sizes for general application in areas where a lower profile is required. Force applied downwards 90° to bar.



'U' Bar (Adjustable) Type with Flanged Base



Dimensions

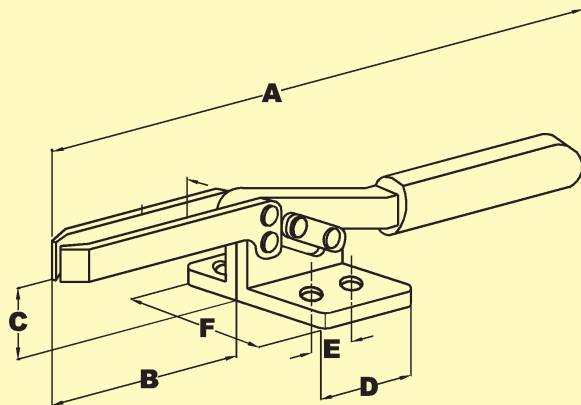

Product Number	A	B	C	D	E	F
AH20-FA	110.0	37.5	24.8	36.5	24.0	30.0
AH80-FA	138.1	55.0	25.4	36.5	25.4	38.0
AH217-FA	168.0	70.0	34.9	38.0	53.4	35.0
AH250-FA	274.0	108.0	45.0	59.0	41.2	59.0
AH340-FA	263.5	108.0	44.4	57.2	41.3	57.2

Product Number	Holding Capacity	Movement Handle	Bar	Base Type	Supplied with	Weight each	Order Code ATL-443	Price/1 TB
AH20-FA	30kg	88°	80°	Flanged	Tipped Spindle (M6) and Flanged Washers	100g	-2020K	611.00
AH80-FA	80kg	60°	85°		Tipped Spindle (M6) and Flanged Washers	130g	-2120K	559.00
AH217-FA	217kg	65°	90°		Tipped Spindle (M8) and Flanged Washers	312g	-2220K	702.00
AH250-FA	250kg	94°	76°		Hexagon Head Spindle (M10) and Flanged Washers	500g	-2620K	1108.00
AH340-FA	340kg	50°	85°		Tipped Spindle (M10) and Flanged Washers	265g	-2420K	815.00

Latch Type Toggle Clamps

Suitable for sealing chamber doors or mould closures. The latched bolts are threaded to allow easy adjustment and provide positive connection with latch plate.



Dimensions

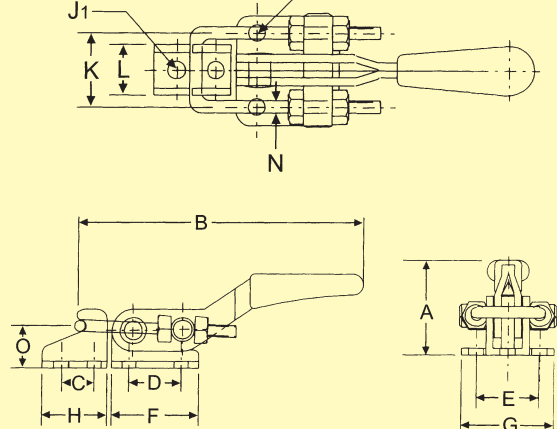

Product Number	A	B	C	D	E	F	G	H	J	J ₁	K	L	N	O
AL165-FU	36	88	9.9	16	19	26	28	45	4.3	4.3	19	13.2	3.3	12
AL320-FU	45	151.6	14	19	31.8	39.6	44.5	25	6.8	6.8	25.4	17.5	4	17
AL900-FU	70.6	190	19	41.4	38	60.5	54	38	8.4	8.4	44.5	30.0	8	24

Product Number	Holding Capacity	Drawing Movement	Drawing Adjust	Base Type	Description	Weight each	Order Code ATL-443	Price/1 TB
AL165-FU	165kg	30mm	9.9mm	Flanged	U-Style Bolt	68g	-4070K	647.00
AL320-FU	320kg	45mm	9.6mm		U-Style Bolt	225g	-4010K	701.00
AL900-FU	900kg	80mm	23.8mm		U-Style Bolt	650g	-4130K	753.00

PRODUCTS ARE ONLY AVAILABLE VIA YOUR DISTRIBUTOR

GROUP 443 TOGGLE CLAMPS

ATLAS WORKHOLDERS

Push Pull Industrial Toggle Clamps

The straight line action gives these plunger-style clamps extremely high loading capacities whilst maintaining compactness. These clamps also lock in the open position which allows a 'pull' to be exerted (for instance, in use with foam moulds). All models have tapped spindles for use with adjustable spindles.

WORKSHOP EQUIPMENT

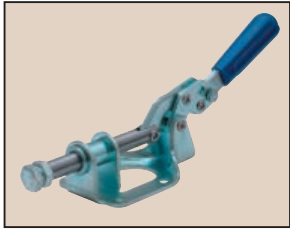

Base Mounted Type - 180° Handle



Base Mounted Type - 190° Handle Movement

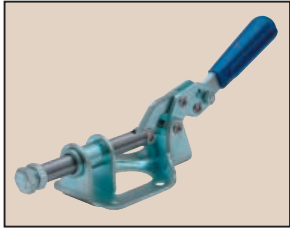

Base Mounted Type - 150° Handle Movement

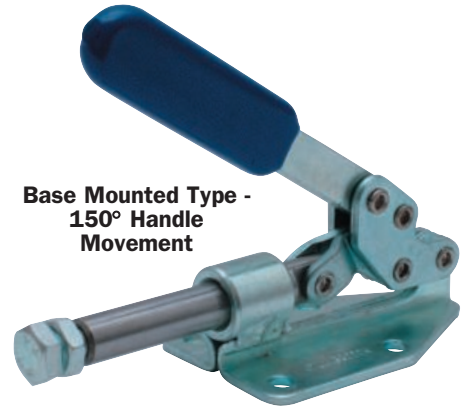

Dimensions

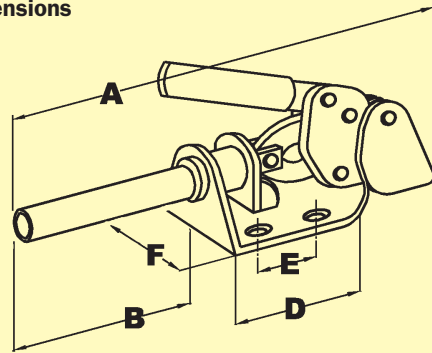

Product Number	A - Excl. Handle	B	C	D	E	F
AP136	138.1	49.2	24.6	88.9	34.9	55.6
AP200	124.5	41.5	14.0	83.0	40.0	50.0
AP227	151.0	63.0	15.0	88.0	32.0	63.0

Product Number	Holding Capacity	Spindle Thread	Handle Movement	Handle Position	Base Type	Supplied With	Weight each	Order Code ATL-443	Price/1 TB
AP136	136kg	M8	180°			Hexagon Head Spindle	285g	-3060K	750.00
AP200	200kg	M8 x 1.25	150°	45°	Flanged	Hexagon Head Spindle	330g	-3090K	780.00
AP227	227kg	M8 x 30 Deep	190°	Extended		Hexagon Head Spindle	540g	-3150K	1029.00

INDEXA

Heavy Duty Weldable Toggle Clamps

Hold down action suitable for high production automotive type applications. Heavy duty forged components with hardened and ground pivot points. The users provide their own handle and bar and weld them to the clamp which is then welded to a base. The flexible mounting of these clamps allows them to be used in situations where standard clamps are not effective.



EXTENDED RANGE

Holding Capacity	Base Width	Clamp Height with Handle	Weight each	Order Code IND-443	Price/1 TB
700kg	28mm	110mm	808g	-5010K	3540.00
700kg	45mm	130mm	915g	-5030K	3540.00
1100kg	50mm	170mm	1574g	-5070K	4547.00
2200kg	63mm	205mm	2881g	-5110K	4500.00

Latch Plates

For use with latch type toggle clamps.



Base Size	Hook Width	Order Code IND-443	Price/1 TB
80 x 55mm	22mm	-8000K	835.00

Swivel Foot Spindles

As Neoprene capped but suitable for clamping onto irregular shapes or angled workpieces.

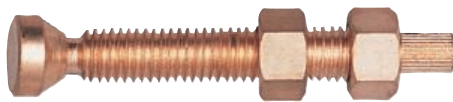

Size	Length	Weight each	Order Code IND-443	Price/1 TB
1/4" UNC	2 1/4"	18g	-8500K	223.00
5/16" UNC	2 3/4"	31g	-8520K	282.00
3/8" UNC	3"	47g	-8540K	329.00
1/2" UNC	4"	115g	-8560K	362.00

Neoprene Caps

For standard adjustable spindles.



To fit Spindle	Weight each	Order Code IND-443	Price/1 TB
1/4"	8g	-8600K	118.00
5/16"	15g	-8620K	118.00
3/8"	24g	-8640K	119.00
1/2"	45g	-8660K	120.00

Flanged Washers

For use in conjunction with all spindles on clamps with adjustable 'U' bars.



To fit Spindle	Weight each	Order Code IND-443	Price/1 TB
5/32" (No.8/M4)	2g	-8700K	120.00
3/16" (No.10)	2g	-8720K	111.00
1/4"	4g	-8740K	121.00
5/16" (M8)	10g	-8780K	122.00
3/8" (M10)	15g	-8800K	123.00
1/2"	37g	-8820K	45.00
5/8"	49g	-8840K	55.00

Neoprene Capped Spindles

For use with adjustable 'U' bar type clamps and solid bar type clamps that have bolt retainers.

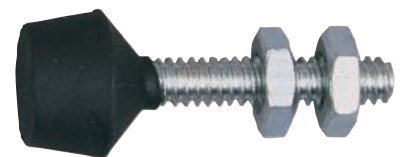

Size	Length	Weight each	Order Code IND-443	Price/1 TB
M4 x 0.7	25mm	5g	-8020K	82.00
M8 x 1.25	63mm	34g	-8100K	82.00
M10 x 1.5	85mm	64g	-8140K	82.00
No 10UNC	1 3/8"	9g	-8200K	125.00
1/4" UNC	1 3/4"	16g	-8220K	147.00
5/16" UNC	2 1/2"	31g	-8260K	148.00
3/8" UNC	3 1/2"	58g	-8300K	212.00
1/2" UNC	3 3/4"	125g	-8340K	332.00

INDEXA Toggle Pliers



WORKSHOP EQUIPMENT

Toggle pliers have the advantage of a pivoting jaw mechanism to allow a deep throat depth to open and close easily for clamping awkward profiles such as steel angle section. The spindle clamping distance and pressure can be pre-set to and is ideal for repetitious applications.

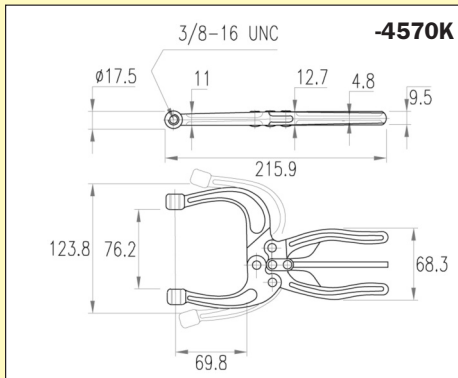
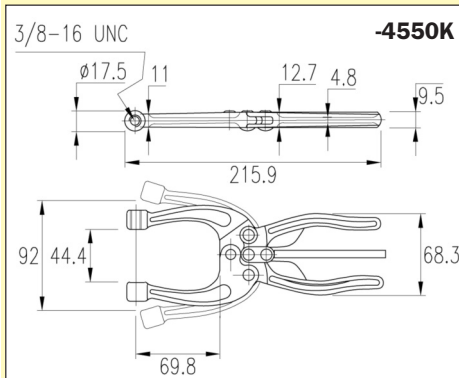
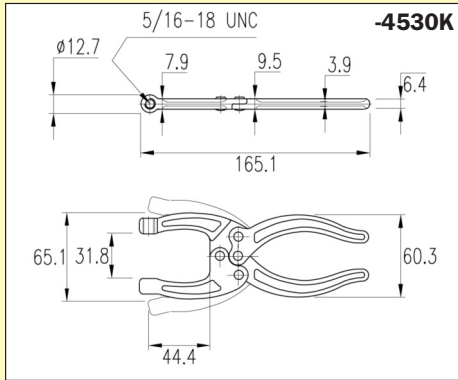
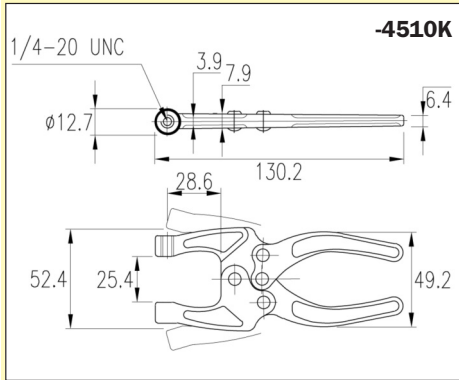

Plain Handle

Holding Capacity	Jaw Opening Min.	Jaw Opening Max.	Standard Spindle Supplied	Order Code IND-443	Price/1 TB
90kg	25.4	52.4	Hex. Head	-4510K	939.00
159kg	31.8	65.1	Hex. Head	-4530K	913.00

Quick Release Handle

Holding Capacity	Jaw Opening Min.	Jaw Opening Max.	Standard Spindle Supplied	Order Code IND-443	Price/1 TB
318kg	44.4	92.0	Swivel	-4550K	1575.00
318kg	76.2	123.8	Hex. Head & Swivel	-4570K	1762.00

Cam Type Toggle G-Clamp (Pull Back Clamp)

To securely fix the clamp into position the base can be welded to the work surface.

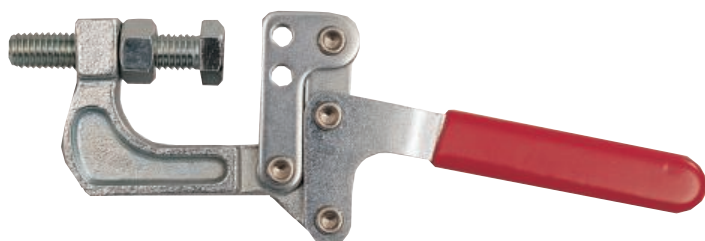
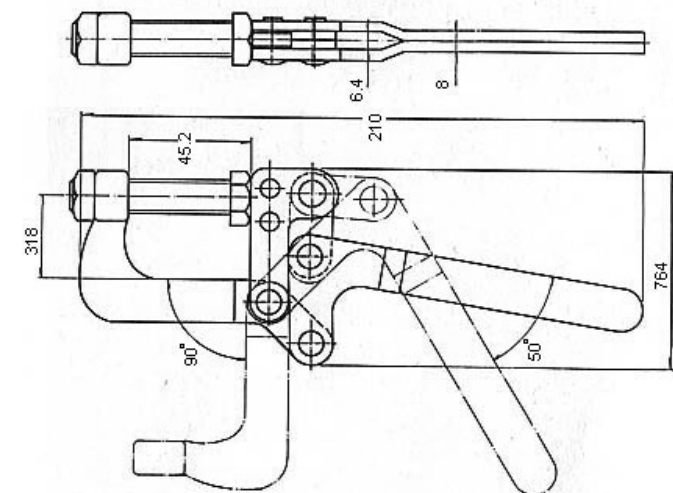

Holding Capacity	Jaw Opening	Jaw Movement	Handle Movement	Order Code IND-443	Price/1 TB
340kg	45.2mm	90°	50°	-5510K	1046.00

'Stub' Type Toggle Pliers

With two stub arms for easy linking to special jaw extensions.

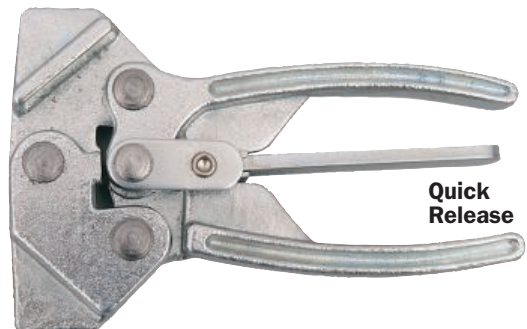
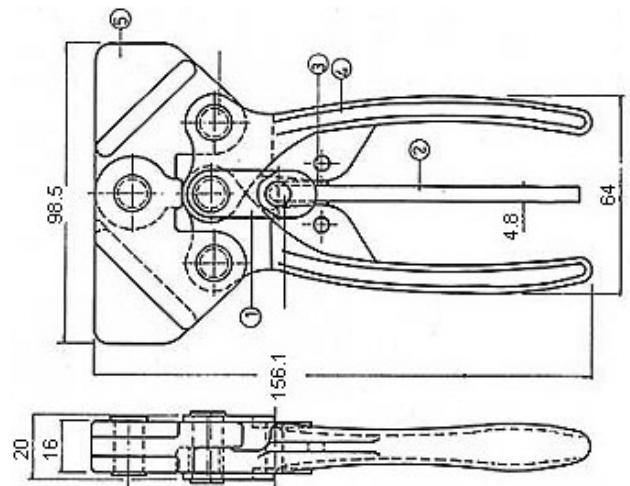

Holding Capacity	Closed Head Width	Overall Length	Order Code IND-443	Price/1 TB
500kg	98.5mm	156.1mm	-4590K	1470.00

PRODUCTS ARE ONLY AVAILABLE VIA YOUR DISTRIBUTOR

GROUP 445 MACHINE VICES

SENATOR Drill Press Vice
QUALITY TOOLING



Suitable for use on pillar/bench drills to steady the workpiece in all light duty drilling applications for the garage or small workshop. Cast construction with machined slots which are spaced to fit all popular drill stand bases. Cross drilled handle with sliding T-bar for extra leverage.



Jaw Width	Maximum Opening	Jaw Height	Dimension Length x Height	Weight each	Order Code SEN-445	Price/1 TB
75mm	55	23	200 x 45	1.90kg	-0750K	979.00
100mm	95	25	250 x 55	3.25kg	-1000K	1236.00

WORKSHOP EQUIPMENT

ATLAS Machine Vices
WORKHOLDERS



Machine Vices without Swivel Base
Manufactured in accordance with high quality criteria. Designed for general purpose milling, planing and drilling applications.

Machine Vices with Swivel Base Type
Also available complete with a swivel base designed for milling, planing and drilling applications. Graduated to 1°.



Swivel Base Type

Jaws are fully ground in pairs

Jaw Width	Max. Opening	Jaw Height	Dimension L x W x H	Weight each	Order Code ATL-445	Price/1 TB
Without Swivel Base						
100mm	80	35	245 x 115 x 89	8kg	-0100K	5520.00
160mm	125	51	411 x 187 x 120	34kg	-0150K	9350.00
200mm	160	63	440 x 220 x 140	46kg	-0200K	11845.00
With Swivel Base						
100mm	80	35	195 x 145 x 110	17kg	-1100K	6101.00
160mm	125	51	411 x 187 x 167	43kg	-1150K	9814.00
200mm	160	63	440 x 220 x 187	57kg	-1200K	12997.00

Spare Jaws to suit Atlas Machine Vices

Width	Order Code ATL-445	Price/1 TB
100mm	-1040K	531.00
160mm	-1060K	823.00
200mm	-1080K	1288.00

Toolmakers Vice - V-Groove Jaw

Made from alloy steel, case hardened. With a quick release mechanism.

Accuracy: 0.005mm.

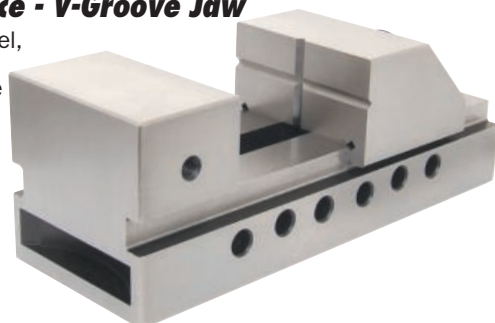

Jaw Dimension Width x Opening x Height	Overall Length	Weight each	Order Code ATL-445	Price/1 TB
50 x 65 x 25mm	135	3kg	-0310K	3826.00

INDEXA Quick Grip Drill Press Vices



Fixed Jaw

Quick acting cam can be set instantly to hold work. Fixed jaw with V-block to handle flat or round pieces, vertically or horizontally. Jaw inserts are hardened and ground. The heavy base can be clamped down to a milling machine or drill press.

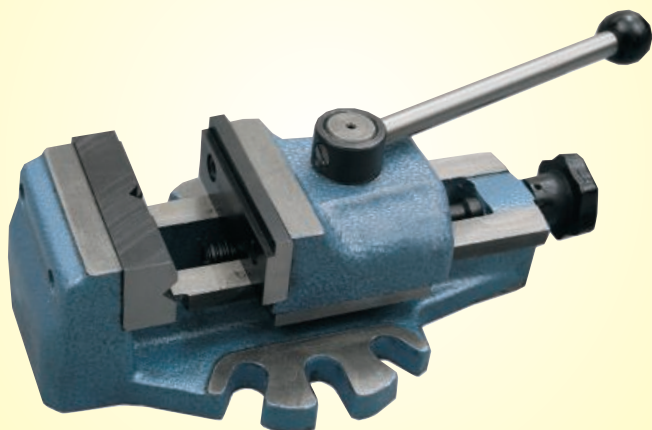

Jaw Width	Jaw Height	Maximum Opening	Weight each	Order Code IND-445	Price/1 TB
80mm	30mm	80mm	5.2kg	-0170K	16995.00
100mm	35mm	100mm	8.9kg	-0180K	21630.00

Toolmaker's Vices

Manufactured from high carbon steel, precision ground on all faces. Phosphor bronze bush, 90° vee on clamping jaws.

Standard Precision Toolmaker's Vices

Squareness and parallelism to within 0.005mm.

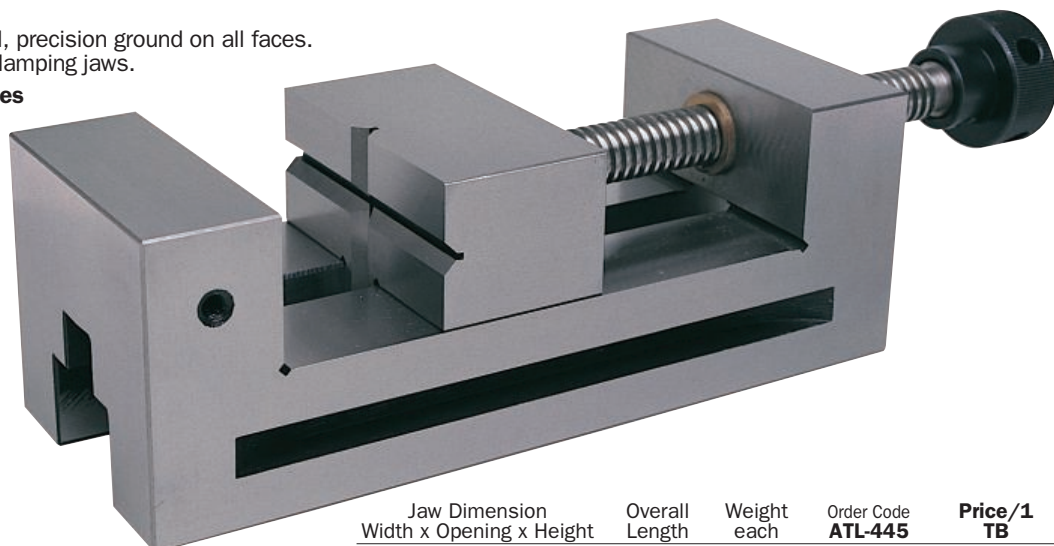

Jaw Dimension Width x Opening x Height	Overall Length	Weight each	Order Code ATL-445	Price/1 TB
63 x 85 x 32mm	185	3.80kg	-2010K	6950.00
100 x 125 x 45mm	255	13.00kg	-2050K	10927.00

INDEXA Drill Press Vices

Available in four different jaw widths. For drilling, light milling, vertical and horizontal work. One grooved and one plain replaceable jaw for square and hexagonal shapes across flats or corners, thin strips and discs. Jaws and lead screw are hardened and ground.



Jaw Width	Jaw Opening	Order Code IND-445	Price/1 TB
85mm	70mm	-0010K	3343.00
100mm	85mm	-0020K	4510.00
120mm	120mm	-0030K	6472.00
150mm	150mm	-0040K	7533.00

Precision Toolmaker's Vices

Squareness and parallelism to within 0.003mm. Designed for precision grinding and many other tool room applications.

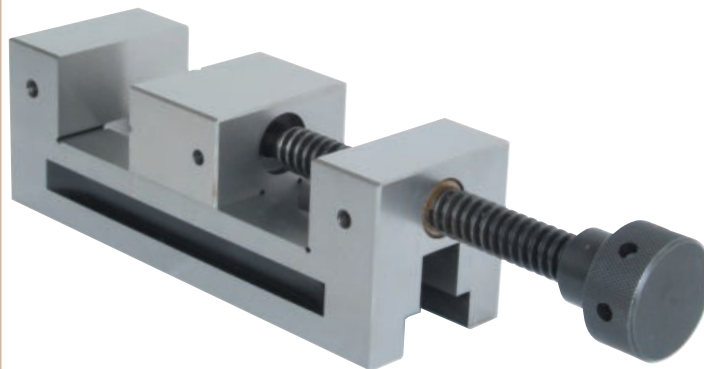

Jaw Dimension Width x Opening x Height	Overall Length	Weight each	Order Code IND-445	Price/1 TB
50 x 65 x 25mm	150	3.00kg	-0400K	10079.00
73 x 100 x 35mm	205	5.00kg	-0430K	13262.00
100 x 125 x 45mm	255	13.00kg	-0450K	19055.00

WORKSHOP EQUIPMENT

Toolmaker's Vices - Plain Jaw

Manufactured from high quality alloy steel, case hardened to HRC 58 - 62. For wire cutting, machining, measurement and inspection. With a dowel pin quick release mechanism with linear scale for accurate alignment.

Accuracy: 0.003mm.

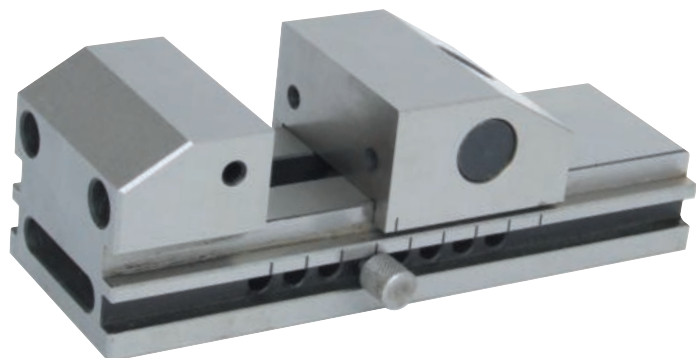

Jaw Dimension Width x Opening x Height	Overall Length	Weight each	Order Code IND-445	Price/1 TB
60 x 80 x 28mm	175mm	3.9kg	-0200K	22660.00
75 x 100 x 40mm	220mm	7.9kg	-0210K	23175.00

Toolmaker's Vise - V-Groove Jaw

Manufactured from high quality alloy steel, case hardened to HRC 58 - 62. With a rack quick release mechanism.

Accuracy: 0.003mm.

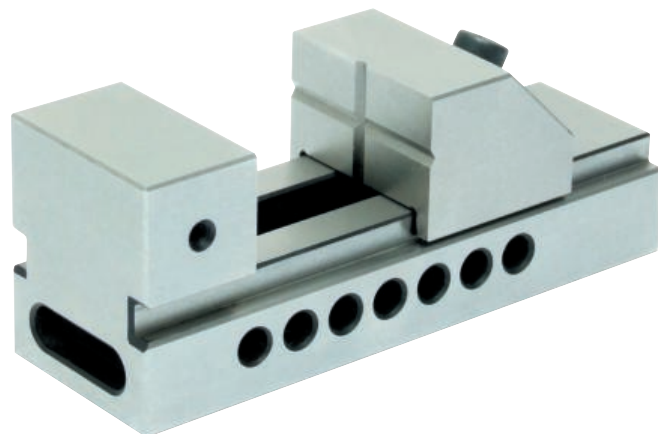

Jaw Dimension Width x Opening x Height	Overall Length	Weight each	Order Code IND-445	Price/1 TB
50 x 78 x 30mm	155mm	3.00kg	-0310K	13905.00

Modular Precision Machine Vices

Precision modular vices are designed to be used on standard and CNC machines for precision grinding and milling. The vice could be set up individually or work in multiples, on tables or palletised components depending on the machined material dimensions. Made from hardened high grade alloy steel.

Perpendicular accuracy: 0.005mm.

Parallelism: 0.005mm.

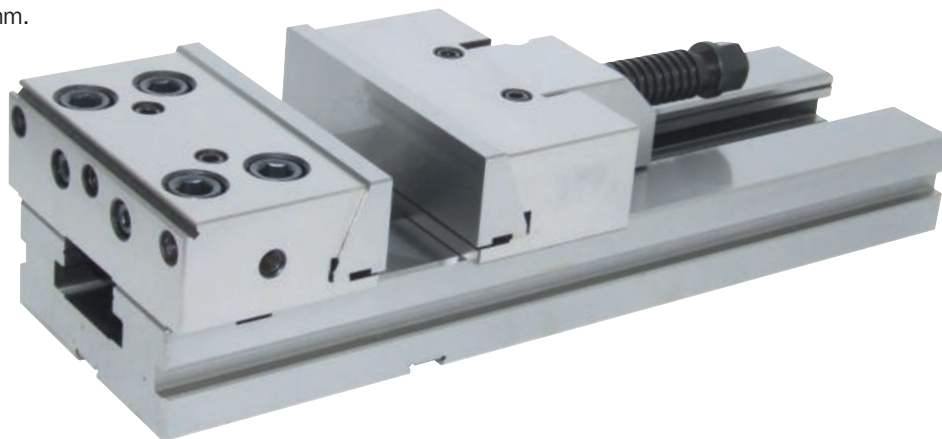

Accessories:

L-wrench, T-wrench, vice holding clamp, work stop with main bolt, positioning key-nuts etc.

Jaw Width x Opening x Height	Overall Length	Clamping Force	Weight each	Order Code IND-445	Price/1 TB
100 x 100 x 30mm	270mm	3000kg	7.00kg	-0600K	46350.00
125 x 150 x 40mm	345mm	3000kg	12.70kg	-0620K	51500.00
150 x 200 x 50mm	420mm	5000kg	25.60kg	-0640K	72100.00
150 x 300 x 50mm	520mm	5000kg	29.50kg	-0660K	77250.00
200 x 300 x 65mm	595mm	8000kg	86.00kg	-0690K	82400.00

Made of alloy case steel. All working surfaces are hardened and precision ground.



Toolposts Type T.00 - T.0

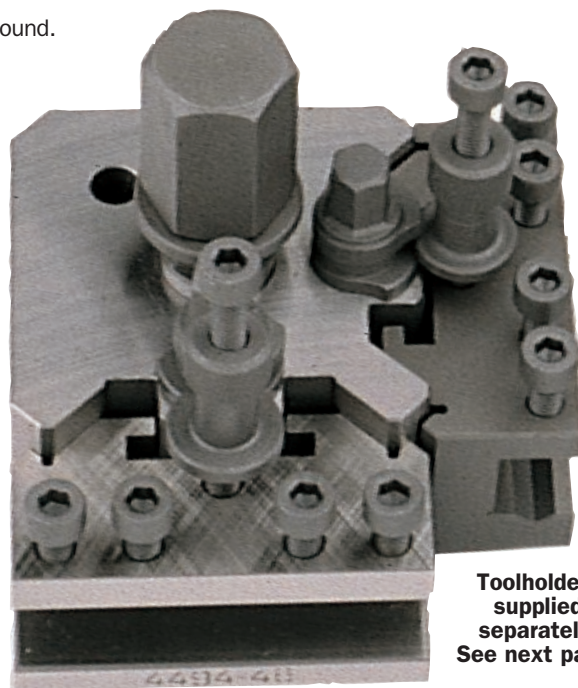
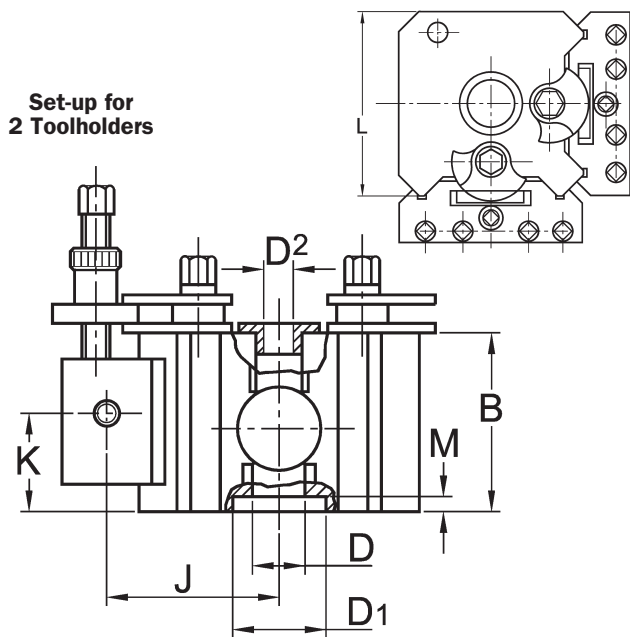

Toolholders supplied separately. See next page.

Type	No. of Toolholders	Lathe Capacity	B	D1 Dia.	M Depth	D	E	G	F	H1 Max	H1 Min.
T.00M	2	Up to 89mm	37.0	-	-	11.2	-	10	11	27	17
T.0	3	Up to 114mm	51.0	22.22	5.0	19.0	124	13	13	36.5	20.5

Type	Bar dia. d Max.	H Max.	H Min.	Taper	J	K Max.	K Min.	L	D2	Weight each	Order Code IND-445	Price/1 TB
T.00M	11.0	22.5	12.5	-	-	28.5	16.0	58.0	-	0.90kg	-4800K	12360.00
T.0	16.0	32.0	16.0	1	52.5	28.5	16.0	73.0	16.0	2.00kg	-4820K	15450.00

Toolposts Type T.1 - T.3

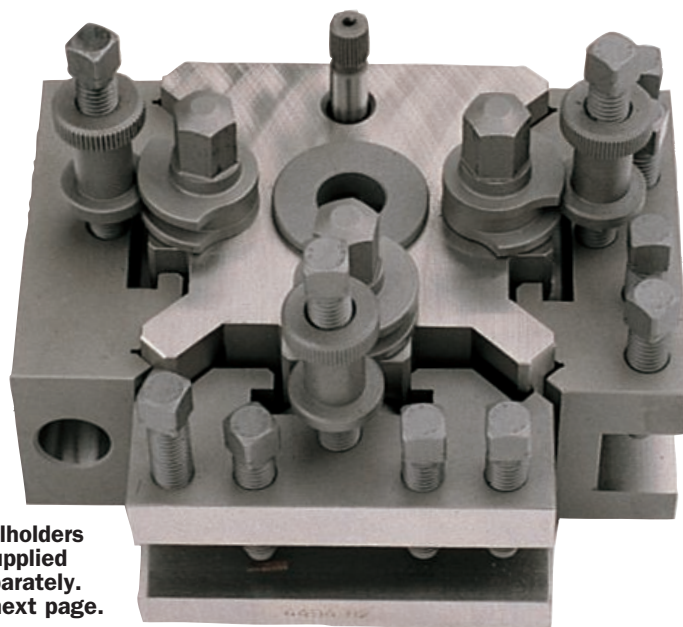
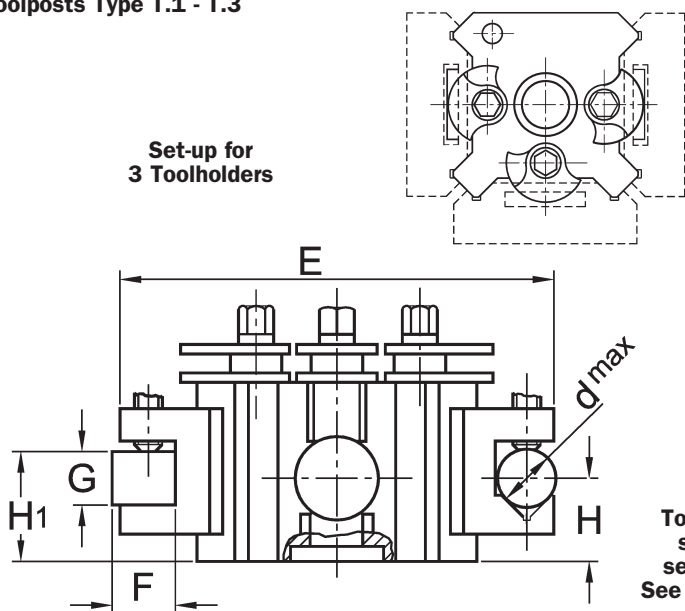

Toolholders supplied separately. See next page.

Type	No. of Toolholders	Lathe Capacity	B	D1 Dia.	M Depth	D	E	G	F	H1 Max	H1 Min.
T.1	3	114 to 127mm	63.5	31.75	6.5	19.0	124	19	13	46	30
T.1X	3	114 to 127mm	73.0	31.75	6.5	19.0	124	19	13	57	35
T.2	3	127 to 203mm	71.5	44.45	8.0	25.5	159	19	19	54	36.5
T.2T	3	127 to 203mm	76.0	44.45	8.0	25.5	168	25.5	25.5	58.5	39.5
T.3	3	203 to 292mm	92.0	50.80	9.5	25.5	203	31.5	22.5	73	51

Type	Bar dia. d Max.	H Max.	H Min.	Taper	J	K Max.	K Min.	L	D2	Weight each	Order Code IND-445	Price/1 TB
T.1	16.0	44.5	25.5	1	52.5	41.0	22.0	73.0	16.0	2.30kg	-4830K	16995.00
T.1X	16.0	54.0	32.0	1 & 2	52.5	51.0	28.5	73.0	16.0	2.60kg	-4840K	18025.00
T.2	19.0	46.0	24.0	2	65.0	47.5	27.0	98.5	16.0	4.60kg	-4850K	20085.00
T.2T	19.0	50.0	24.0	2 & 3	70.0	47.5	27.0	106.5	16.0	5.80kg	-4860K	22660.00
T.3	25.5	51.0	28.5	3	85.5	58.5	36.5	125.5	22.0	10.8kg	-4870K	28840.00

INDEXA Toolholders for Quick Change Toolposts

Standard Type

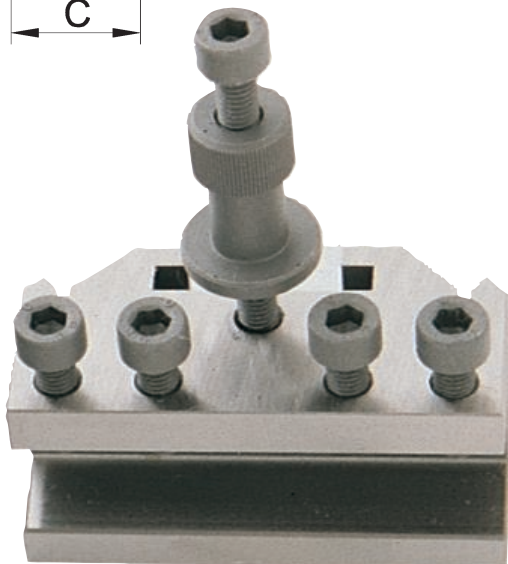
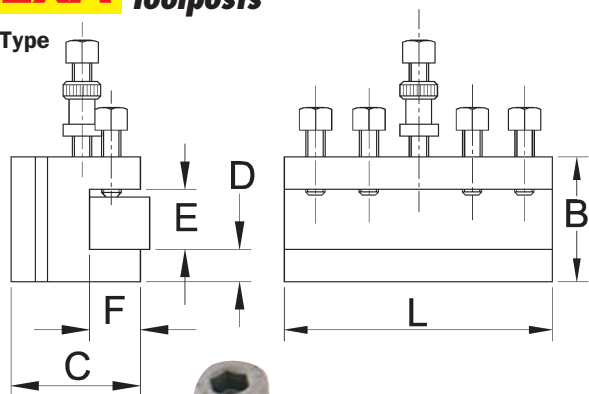

Used On	L (mm)	B	C	D	E	F	Order Code IND-445	Price/1 TB
T.00	58.0	27.0	28.0	7.0	13.0	11	-5010K	3090.00
T.0	73.0	35.0	32.0	8.0	16.0	14	-5020K	4635.00
T.1	73.0	44.5	32.0	11.0	22.0	14	-5030K	6180.00
T.2	98.5	50.0	40.0	12.0	22.0	19	-5040K	7210.00
T.2T	98.5	57.0	40.0	14.0	28.5	19	-5050K	7468.00
T.3	124.0	70.0	48.5	17.5	35.0	23	-5060K	8755.00

Parting Off Type

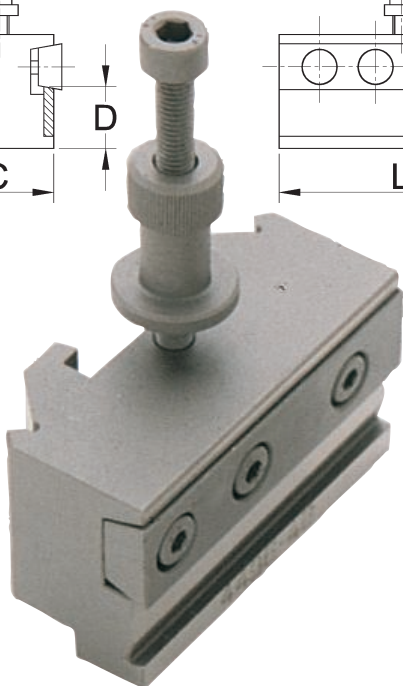
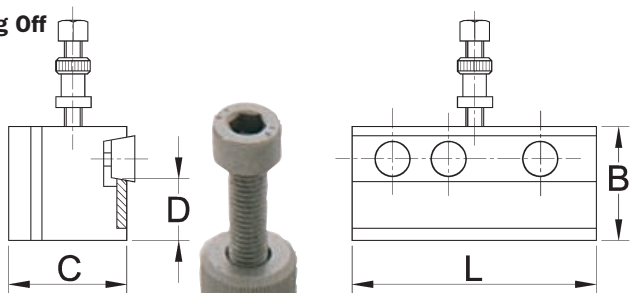

Used On	L (mm)	B	C	D	Order Code IND-445	Price/1 TB
T.0/T.1	73.0	47.5	32.0	27.0	-5370K	7571.00
T.2	98.5	57.0	39.5	33.5	-5380K	9734.00

Vee Type

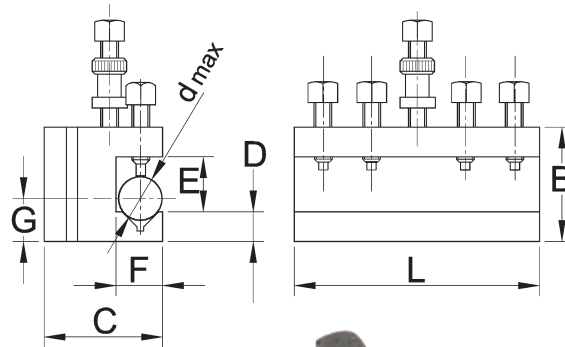

Used On	L (mm)	B	C	D	E	F	G	d Max	Order Code IND-445	Price/1 TB
T.00	58.0	27.0	28.0	8.0	13.0	11	13.5	11.0	-5110K	4120.00
T.0	73.0	35.0	32.0	8.0	16.0	14	16.0	16.0	-5120K	4635.00
T.1	73.0	44.5	32.0	16.0	17.0	14	24.0	16.0	-5130K	6695.00
T.2	98.5	50.0	40.0	14.0	22.0	19	24.0	19.0	-5140K	7725.00
T.2T	98.5	57.0	40.0	14.0	28.5	19	24.0	19.0	-5150K	7828.00
T.3	124.0	70.0	48.5	17.5	35.0	23	28.5	25.5	-5160K	8395.00

Industrial Lathe Carriers

Available with straight or bent tail. Manufactured from high grade, malleable cast iron with high tensile strength. Smooth action square head clamping screw.



Straight

Type	Capacity	Weight each	Order Code IND-445	Price/1 TB
Straight	12.5mm	0.10kg	-9000K	1133.00
	19.0mm	0.15kg	-9010K	1339.00
	25.0mm	0.30kg	-9020K	1545.00
	38.0mm	0.70kg	-9040K	2266.00
	50.0mm	1.50kg	-9060K	3605.00



Bent

Type	Capacity	Weight each	Order Code IND-445	Price/1 TB
Bent	12.5mm	0.10kg	-9200K	1545.00
	19.0mm	0.15kg	-9210K	1700.00
	25.0mm	0.30kg	-9220K	2009.00
	38.0mm	0.70kg	-9240K	2575.00
	50.0mm	1.50kg	-9260K	3605.00

PRODUCTS ARE ONLY AVAILABLE VIA YOUR DISTRIBUTOR

GROUP 445 BENCH VICES

WORKSHOP EQUIPMENT

KENNEDY PROFESSIONAL

Steel Bench Vices



These premium quality bench vices are as good as you get, made from solid steel with replaceable jaws, integral pipe jaws and anvil for versatility.

Available in
100mm (4")
150mm (6")
200mm (8").



EXTENDED RANGE

Model Number	Opening (mm)	Jaw Width (mm)	Weight each	Order Code KEN-445	Price/1 TB
VBS100	100 (4")	90 (3 ⁹ / ₁₆ ")	6.30kg	-0500K	7209.00
VBS150	150 (6")	150 (6")	18.25kg	-0540K	10299.00
VSB200	200 (8")	205 (8")	25.00kg	-0300K	15965.00

KENNEDY QUALITY INDUSTRIAL TOOLING

Engineer's Vice

Manufactured from the highest quality castings with precision cut screw mechanisms and precision machined jaws.

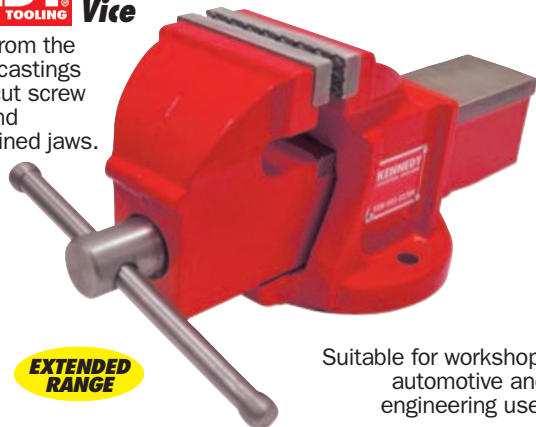

EXTENDED RANGE

Suitable for workshop, automotive and engineering use.

Model Number	Opening (mm)	Jaw Width (mm)	Weight each	Order Code KEN-445	Price/1 TB
KECV75	100 (4")	75 (3")	4.50kg	-0230K	2833.00
KECV100	140 (5 ⁵ / ₈ ")	100 (4")	9.50kg	-0240K	3348.00
KECV125	170 (6 ³ / ₄ ")	125 (5")	18.0kg	-0250K	4687.00
KECV150	190 (7 ⁵ / ₈ ")	150 (6")	25.0kg	-0260K	6489.00
KECV200	210 (8 ¹ / ₄ ")	200 (8")	40.0kg	-0280K	9013.00

Replacement Jaws (Pairs)

Engineers Vice Size (Pair)	Height (mm)	Order Code KEN-567	Price/1 TB
To suit 75mm jaw width	16	-3630K	617.00
To suit 100mm jaw width	20	-3640K	617.00
To suit 125mm jaw width	21	-3650K	1029.00
To suit 150mm jaw width	21	-3660K	1288.00
To suit 200mm jaw width	28	-3680K	1545.00

Workshop Vice - American Pattern

American pattern, bench mounting steel vice with anvil suitable for workshop, garage and machine-shop use. Fixed base directly mounts onto work bench. Cast iron body with steel jaws and a cross drilled threaded handle with adjustable T-bar for extra leverage.

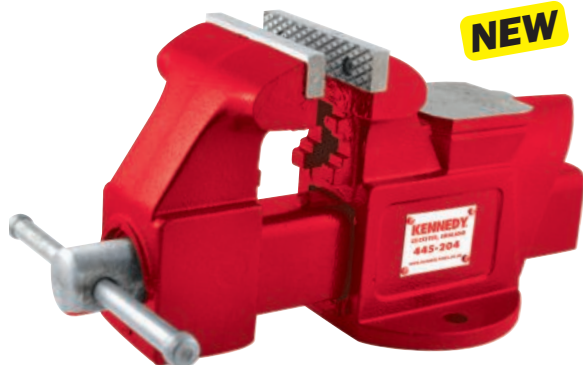

NEW

Opening (mm)	Jaw Width (mm)	Weight each	Order Code KEN-445	Price/1 TB
127 (5")	100 (4")	12.3kg	-2040K	3708.00
178 (7")	150 (6")	25.0kg	-2060K	7159.00

SENATOR QUALITY TOOLING

Portable Bench Vice



Lightweight and portable with a swivel base and light duty anvil.

Ideal for model makers, DIY and light industrial use. Can be fitted to any convenient work surface. Solid cast grey iron body with steel guide rods and main screw.



Opening (mm)	Jaw Width	Weight each	Order Code SEN-445	Price/1 TB
70 (2 ³ / ₄ ")	60	2.8kg	-0600K	1040.00

Universal Vice

Can be bench mounted either vertically or horizontally, and on either side. Unique design permits the vice to rotate a full 360° then self-lock when jaws are tightened.

Jaw height: 54mm (2¹/₈").

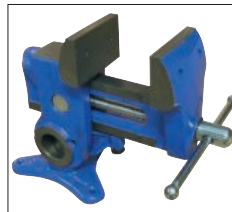
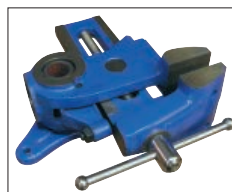

Opening (mm)	Jaw Width	Weight each	Order Code SEN-445	Price/1 TB
125 (5")	90 (3 ¹ / ₂ ")	8.2kg	-4050K	3278.00

Light Duty Bench Vice

For light workshop, engineering and automotive use. Cast iron body with precision cut screw mechanism. The base bolts directly to the work bench surface for stability.



Do Not Strike With A Hammer



Opening (mm)	Jaw Width (mm)	Weight each	Order Code SEN-445	Price/1 TB
127 (5")	100 (4")	5.5kg	-0510K	2494.00
170 (6 ¹ / ₂ ")	125 (5")	11.3kg	-0520K	3395.00
190 (7 ¹ / ₂ ")	150 (6")	15.3kg	-0530K	4616.00

INDEXA Modular Coolant Hose System

Modular coolant hose system is ideal for coolants, fluids and air lines. Suitable for all wet machining, spark erosion and air line operations up to 50PSI air and 30PSI liquid. Flow direction is easily and accurately positioned with no spring-back. All parts are fully interchangeable and fully replaceable if a single section is damaged. Manufactured from acetal - non-conductive and chemical resistant. Available with 1/4", 1/2" and 3/4" bore. Hose is green, all other fittings are orange. Threaded fittings are fully compatible with BSPT.

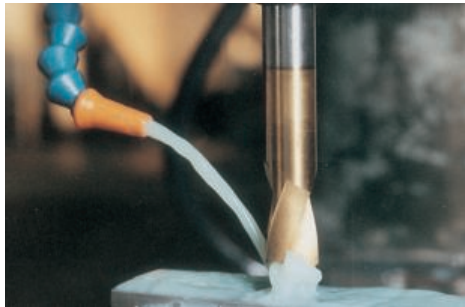

Starter Packs

Contents	Weight each	Order Code IND-447	Price/1 TB
1/4" Bore			
12" Hose			
4 Nozzles	40g	-6910K	1219.00
2 Connectors			
1/2" Bore			
13" Hose			
3 Nozzles	91g	-7910K	1285.00
2 Connectors			
3/4" Bore			
14" Hose			
2 Nozzles	126g	-8910K	1668.00
1 Connectors			

Tube Segments



Bore Size	Weight each	Order Code IND-447	Price/1 TB
11" Lengths (Green)			
1/4"	40g	-6210K	1040.00
1/2"	69g	-7210K	1092.00
3/4"	102g	-8210K	1433.00
11" Lengths (Blue)			
3/4"	102g	-8230K	870.00
25ft Bulk Pack (Green)			
1/4"	886g	-6250K	12677.00
1/2"	1637g	-7250K	14835.00
3/4"	2381g	-8250K	17261.00

Modular Manifold Kits

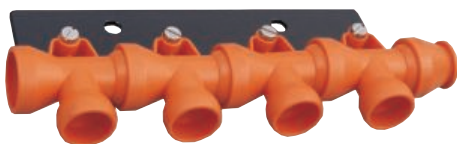

Description	Bore Size	Weight each	Order Code IND-447	Price/1 TB
4x T-Pieces, 2x Plug, 1x Bracket, 4x Screws	1/4"	109g	-6450K	1088.00
	1/2"	98g	-7450K	1219.00

Modular Coolant Hose System Threaded Spigots

Male Spigot



Bore Size	Inlet Size	Weight each	Order Code IND-447	Price/1 TB
1/4"	1/8" NPT Female	2g	-6710K	137.00
	1/4" NPT Female	2g	-6730K	137.00
1/4"	1/8" NPT Male	2g	-6170K	94.00
	1/4" NPT Male	2g	-6190K	94.00
1/2"	3/8" NPT Male	7g	-7170K	116.00
	1/2" NPT Male	7g	-7190K	116.00
3/4"	1/2" NPT Female	7g	-7730K	137.00
	3/4" NPT Male	10g	-8170K	137.00

Nozzles

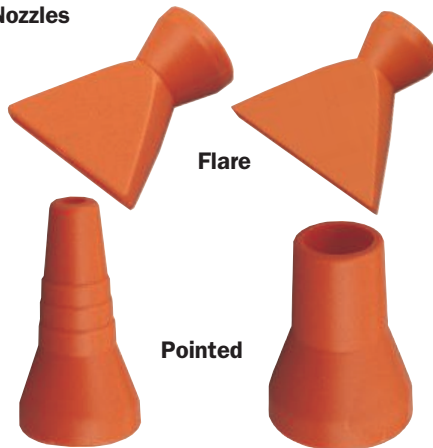

Flare

Pointed

Type	Size	Weight each	Order Code IND-447	Price/1 TB
1/4" Bore				
Pointed	1/16"	5g	-6610K	94.00
	1/8"	5g	-6630K	105.00
	3/16"	5g	-6640K	116.00
	1/4"	5g	-6650K	126.00
Flare	1"	5g	-6670K	215.00
	1/2" Bore			
Pointed	1/4"	5g	-7610K	121.00
	3/8"	5g	-7630K	137.00
	1/2"	5g	-7650K	137.00
Flare	1 3/4"	5g	-7670K	291.00
	2 1/2"	5g	-7690K	466.00
3/4" Bore				
Pointed	5/8"	10g	-8610K	137.00
	3/4"	10g	-8630K	137.00
Flare	3"	10g	-8650K	546.00

Plastic Valves

1/4 turn fitting.



Bore Size	Inlet Type	Weight each	Order Code IND-447	Price/1 TB
1/4"	In-line	10g	-6050K	384.00
1/2"	In-line	30g	-7050K	433.00

Metal Ball Valves

Threaded fitting 1/4 turn.



NPT Threads Male x Female	Weight each	Order Code IND-447	Price/1 TB
1/8" x 1/8"	81g	-6070K	357.00
1/4" x 1/4"	80g	-6090K	384.00
3/8" x 3/8"	76g	-7070K	433.00
1/2" x 1/2"	114g	-7090K	433.00

COOLANT HOSE Modular Coolant Hose System

Junction Pieces



L-Piece

Y-Piece

Type	Weight each	Order Code IND-447	Price/1 TB
1/4" Bore			
Y-Piece	3g	-6310K	247.00
T-Piece	3g	-6350K	280.00
L-Piece	4g	-6370K	280.00
1/2" Bore			
Y-Piece	9g	-7310K	274.00
T-Piece	9g	-7350K	313.00
L-Piece	12g	-7370K	328.00

Junction Reducers



Type	Weight each	Order Code IND-447	Price/1 TB
1/2" Bore			
1/2" to 2 x 1/4"	4g	-7330K	318.00
1/2" to 1/4"	3g	-7510K	230.00
3/4" Bore			
3/4" to 1/2"	5g	-8510K	247.00

INDEXA

Quick Set Machine Shields

14" (3/4" bore) hose length. Suitable for small machine tools. Fully adjustable with magnetic base.



Visor Size	Weight each	Order Code IND-447	Price/1 TB
6" x 8"	500g	-0250K	3361.00
7 1/2" x 10"	570g	-0260K	3689.00

Quick Action Assembly Pliers



Bore Size	Order Code IND-447	Price/1 TB
1/4"	-0010K	2575.00
1/2"	-0020K	2812.00



INDEXA Die Springs

The heat and surface treatment plus the high quality of steel used in the manufacturing process ensure the springs will bear a high number of stresses without breaking or without appreciable loss of load. Every batch of springs is subject to a rigorous testing procedure to ensure that a consistent quality is maintained. Longer springs should be guided along their course.

**Heavy-Load Springs
Colour Coded Red**



**Extra Heavy-Load Springs
Colour Coded Yellow**



Product Number	Diameter DH	Dd	L ₀ (mm)	Rigidity (N/mm)	Weight each	Order Code IND-460	Price/1 TB
R10 x 25	10	4.5	25	22.10	4g	-1000A	78.00
R10 x 32	10	4.5	32	17.50	5g	-1001B	88.00
R10 x 38	10	4.5	38	17.10	6g	-1002C	98.00
R10 x 44	10	5.0	180	15.00	8g	-1003D	98.00
R10 x 51	10	4.5	51	12.80	8g	-1004E	109.00
R10 x 64	10	4.5	64	10.7	11g	-1005F	119.00
R13 x 25	13	7.0	25	42.1	12g	-1108J	98.00
R13 x 38	13	7.0	38	29.3	13g	-1110L	119.00
R13 x 44	13	7.0	44	24.6	15g	-1111M	129.00
R13 x 51	13	7.0	51	19.6	17g	-1112N	129.00
R13 x 64	13	7.0	64	15.0	21g	-1113P	150.00
R13 x 76	13	7.0	76	13.2	24g	-1114Q	170.00
R16 x 25	16	8.0	25	75.7	12g	-1216S	150.00
R16 x 32	16	8.0	32	52.8	14g	-1217T	150.00
R16 x 38	16	8.0	38	48.5	17g	-1218V	150.00
R16 x 44	16	8.0	44	42.8	20g	-1219W	170.00
R16 x 51	16	8.0	51	37.1	23g	-1220X	170.00
R16 x 64	16	8.0	64	30.3	27g	-1221Y	170.00
R16 x 76	16	8.0	76	25.7	34g	-1222Z	176.00
R20 x 25	20	10.0	25	216.0	20g	-1326D	145.00
R20 x 32	20	10.0	32	168.0	28g	-1327E	160.00
R20 x 38	20	10.0	38	129.0	32g	-1328F	170.00
R20 x 44	20	10.0	44	112.0	38g	-1329G	181.00
R20 x 51	20	10.0	51	94.0	44g	-1330H	201.00
R20 x 64	20	10.0	64	72.1	54g	-1331J	206.00
R20 x 76	20	10.0	76	59.7	63g	-1332K	222.00
R20 x 89	20	10.0	89	50.5	75g	-1333L	258.00
R20 x 102	20	10.0	102	44.2	88g	-1334M	361.00
R20 x 127	20	10.0	127	34.1	107g	-1336P	670.00
R25 x 32	26	12.5	32	297.0	48g	-1441V	201.00
R25 x 38	26	12.5	38	219.0	56g	-1442W	201.00
R25 x 44	26	12.5	44	187.0	57g	-1443X	222.00
R25 x 51	26	12.5	51	156.0	63g	-1444Y	284.00
R25 x 64	26	12.5	64	123.0	85g	-1445Z	284.00
R25 x 76	26	12.5	76	99.0	110g	-1446A	304.00
R25 x 89	26	12.5	89	84.0	139g	-1447B	335.00
R25 x 102	26	12.5	102	73.0	144g	-1448C	361.00
R25 x 115	26	12.5	115	65.0	168g	-1449D	387.00
R25 x 127	26	12.5	127	57.7	182g	-1450E	438.00
R25 x 152	26	12.5	152	47.8	222g	-1452G	464.00
R25 x 178	26	12.5	178	41.0	256g	-1453H	773.00
R32 x 38	32	16.0	38	388.0	93g	-1557M	232.00
R32 x 44	32	16.0	44	324.0	105g	-1558N	258.00
R32 x 51	32	16.0	51	272.0	117g	-1559P	284.00
R32 x 64	32	16.0	64	212.0	148g	-1560Q	335.00
R32 x 76	32	16.0	76	172.0	178g	-1561R	361.00
R32 x 89	32	16.0	89	141.0	204g	-1562S	407.00
R32 x 102	32	16.0	102	122.0	230g	-1563T	593.00
R32 x 152	32	16.0	152	78.0	380g	-1567Y	979.00
R32 x 178	32	16.0	178	67.2	410g	-1568Z	1133.00
R40 x 51	40	20.0	51	350.0	181g	-1672D	335.00
R40 x 64	40	20.0	64	269.0	220g	-1673E	361.00
R40 x 76	40	20.0	76	219.0	261g	-1674F	670.00
R40 x 89	40	20.0	89	190.0	315g	-1675G	773.00
R40 x 102	40	20.0	102	163.0	341g	-1676H	850.00
R40 x 127	40	20.0	127	128.0	420g	-1678K	1288.00
R40 x 152	40	20.0	152	105.0	500g	-1680M	1339.00
R50 x 64	51	25.0	64	413.0	416g	-1785S	1133.00
R50 x 76	51	25.0	76	339.0	438g	-1786T	1236.00

Product Number	Diameter DH	Dd	L ₀ (mm)	Rigidity (N/mm)	Weight each	Order Code IND-460	Price/1 TB
G10 x 25	10	4.5	25	36.8	5g	-3000A	98.00
G10 x 32	10	4.5	32	27.9	7g	-3001B	155.00
G10 x 38	10	4.5	38	23.7	8g	-3002C	155.00
G10 x 44	10	4.5	44	19.2	9g	-3003D	155.00
G10 x 51	10	4.5	51	16.5	10g	-3004E	155.00
G10 x 64	10	5.0	64	13.2	11g	-3005F	155.00
G13 x 25	13	7.0	25	58.5	11g	-3108J	155.00
G13 x 32	13	7.0	32	43.9	11g	-3109K	155.00
G13 x 38	13	7.0	38	3.70	13g	-3110L	155.00
G13 x 44	13	7.0	44	30.3	15g	-3111M	155.00
G13 x 51	13	7.0	51	26.2	80g	-3112N	160.00
G13 x 64	13	7.0	64	21.2	22g	-3113P	232.00
G16 x 32	16	8.0	32	89.0	17g	-3217T	134.00
G16 x 38	16	8.0	38	72.1	22g	-3218V	145.00
G16 x 44	16	8.0	44	60.9	25g	-3219W	258.00
G16 x 51	16	8.0	51	52.3	29g	-3220X	361.00
G16 x 64	16	8.0	64	41.2	36g	-3221Y	366.00
G16 x 76	16	8.0	76	34.1	42g	-3222Z	351.00
G20 x 25	20	10.0	25	293.0	23g	-3326D	155.00
G20 x 32	20	10.0	32	224.0	28g	-3327E	181.00
G20 x 38	20	10.0	38	177.0	33g	-3328F	191.00
G20 x 44	20	10.0	44	149.0	39g	-3329G	201.00
G20 x 51	20	10.0	51	128.0	45g	-3330H	217.00
G20 x 64	20	10.0	64	99.0	56g	-3331J	222.00
G20 x 76	20	10.0	76	81.7	64g	-3332K	232.00
G20 x 89	20	10.0	89	69.5	73g	-3333L	464.00
G20 x 102	20	10.0	102	60.6	86g	-3334M	490.00
G25 x 32	26	12.5	32	374.4	48g	-3441V	181.00
G25 x 38	26	12.5	38	346.0	60g	-3442W	201.00
G25 x 44	26	12.5	44	244.0	70g	-3443X	222.00
G25 x 51	26	12.5	51	207.5	80g	-3444Y	232.00
G25 x 64	26	12.5	64	161.0	99g	-3445Z	258.00
G25 x 76	26	12.5	76	130.8	114g	-3446A	284.00
G25 x 89	26	12.5	89	110.5	134g	-3447B	304.00
G25 x 102	26	12.5	102	96.3	151g	-3448C	361.00
G25 x 115	25	12.5	115	85.7	174g	-3449D	387.00
G25 x 127	26	12.5	127	76.3	190g	-3450E	617.00
G32 x 38	32	16.0	38	528.2	98g	-3557M	284.00
G32 x 44	32	16.0	44	424.4	115g	-3558N	304.00
G32 x 51	32	16.0	51	353.0	131g	-3559P	325.00
G32 x 64	32	16.0	64	269.2	163g	-3560Q	361.00
G32 x 76	32	16.0	76	218.5	200g	-3561R	397.00
G32 x 89	32	16.0	89	180.3	226g	-3562S	567.00
G32 x 102	32	16.0	102	155.0	252g	-3563T	593.00
G32 x 140	32	16.0	140	112.3	350g	-3566X	979.00
G32 x 152	32	16.0	152	102.0	380g	-3567Y	999.00
G40 x 51	40	20.0	51	628.0	190g	-3672D	361.00
G40 x 64	40	20.0	64	487.0	238g	-3673E	438.00
G40 x 76	40	20.0	76	379.0	275g	-3674F	464.00
G40 x 89	40	20.0	89	321.0	330g	-3675G	670.00
G50 x 64	50	25.0	64	709.0	410g	-3785S	773.00
G50 x 89	51	25.0	89	475.0	593g	-3787V	876.00

PRODUCTS ARE ONLY AVAILABLE VIA YOUR DISTRIBUTOR

ATLAS WORKHOLDERS Bench Shears

Hand operated, compound lever action bench shears. Capable of rapidly cutting through metal plate, strip and bar. Solid steel frame for rigidity and strength. With hardened and precision ground blades for accurate cutting. Adjustable blade guard.

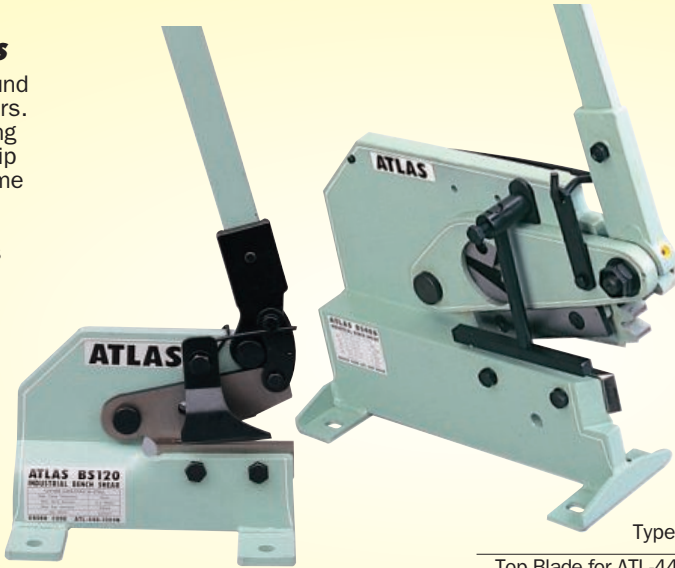

Model Number	Plate	Maximum Strip	Bar	Jaw Width	Weight each	Order Code	Price/1 TB
BS120	4mm	5 x 70	10	120	8.3kg	-1200K	8743.00
BS200	6mm	7 x 70	13	200	19.0kg	-2000K	14935.00
BS406	8mm	10 x 100	16	200	43.0kg	-3000K	36050.00

Type	Weight each	Order Code	Price/1 TB
Top Blade for ATL-448-1200K Shear	445g	-3100K	2380.00
Bottom Blade for ATL-448-1200K Shear	250g	-3110K	1464.00
Top Blade for ATL-448-2000K Shear	1.4kg	-3150K	6711.00
Bottom Blade for ATL-448-2000K Shear	790g	-3160K	3050.00
Top Blade for ATL-448-3000K Shear	430g	-3200K	2136.00
Bottom Blade for ATL-448-3000K Shear	220g	-3210K	3050.00

JHL Single Knurl Toolholder

Machine ground high grade steel, black mottle finish. Fitted as standard with medium pitch straight hand knurl. Right, left and checkered also available separately, see table below. For use with knurl size 3/4" x 1/4" x 1/4".



Size	Knurls Fitted	Weight each	Order Code	Price/1 TB
1/2" x 1/2" x 4"	-1510B	140g	-8050F	3193.00

Style	Weight each	Order Code JHL-450			Price/1 TB
		Coarse	Medium	Fine	
Straight	10g	-1500A	-1510B	-1520C	876.00
Right Hand	10g	-1600A	-1610B	-1620C	876.00
Left Hand	10g	-1700A	-1710B	-1720C	876.00
Checkered	10g	-1800A	-1810B	-1820C	876.00

Six Knurl Toolholder

Machine ground high grade steel, black mottle finish. Revolving head. For use with knurl size 3/4" x 3/8" x 1/4".



Size	Knurls Fitted	Weight each	Order Code	Price/1 TB
1/2" x 1 1/8" x 6 1/2"	-1110B & -1210B	640g	-8000A	19055.00

Two Knurl Toolholder

Machine ground high grade steel, black mottle finish. Self-adjusting head. For use with knurl size 3/4" x 3/8" x 1/4".



Size	Knurls Fitted	Weight each	Order Code	Price/1 TB
1/2" x 7/8" x 6 1/2"	-1110B & -1210B	290g	-8020C	15299.00

Style	Weight each	Order Code JHL-450			Price/1 TB
		Coarse	Medium	Fine	
Straight	10g	-1000A	-1010B	-1020C	903.00
Right Hand	10g	-1100A	-1110B	-1120C	903.00
Left Hand	10g	-1200A	-1210B	-1220C	903.00
Checkered	10g	-1300A	-1310B	-1320C	1803.00

Two Knurl Toolholder

Side knurling up to a face or shoulder. For use with knurl size 25 x 10 x 16mm.



Size	Knurls Fitted	Weight each	Order Code	Price/1 TB
20 x 25 x 85mm	-3110B & -3210B	900g	-8040E	25750.00

25 x 10 x 16mm Knurls to suit Toolholder above

Style	Weight each	Order Code JHL-450			Price/1 TB
		Coarse	Medium	Fine	
Straight	10g	-3000A	-3010B	-3020C	1906.00
Right Hand	10g	-3100A	-3110B	-3120C	1906.00
Left Hand	10g	-3200A	-3210B	-3220C	1906.00

Two Knurl Toolholder

Machine ground high grade steel, black mottle finish. Self-adjusting head. For use with knurl size 5/8" x 5/16" x 7/32".



Size	Knurls Fitted	Weight each	Order Code	Price/1 TB
3/8" x 7/8" x 5 1/2"	Supplied separately	390g	-8030D	15299.00

5/8" x 5/16" x 7/32" Knurls to suit Toolholder above

Style	Weight each	Order Code JHL-450			Price/1 TB
		Coarse	Medium	Fine	
Straight	10g	-2000A	-2010B	-2020C	876.00
Right Hand	10g	-2100A	-2110B	-2120C	876.00
Left Hand	10g	-2200A	-2210B	-2220C	876.00
Checkered	10g	-2300A	-2310B	-2320C	1313.00

Six Knurl Toolholder

Machine ground high grade steel, black mottle finish. Revolving head. For use with knurl size 5/8" x 3/16" x 1/4".



Size	Knurls Fitted	Weight each	Order Code	Price/1 TB
1/2" x 7/8" x 6 1/2"	-2610B & -2710B	930g	-8010B	18025.00

5/8" x 3/16" x 1/4" Knurls to suit Toolholder above

Style	Weight each	Order Code JHL-450			Price/1 TB
		Coarse	Medium	Fine	
Straight	10g	-2500A	-2510B	-2520C	979.00
Right Hand	10g	-2600A	-2610B	-2620C	1029.00
Left Hand	10g	-2700A	-2710B	-2720C	1029.00
Checkered	10g	-2800A	-2810B	-	1029.00



INDEXA Self-Centring Geared Scroll Lathe Chucks

Universal. Scrolls are forged, balanced and hardened. Thread flanks are ground on both sides. All models have grease nipples for easy lubrication and are supplied with two sets of solid jaws - internal and external stepped.

Cast Iron 3 Jaw Plain Back Chuck

DIN 6350 (form A).

Three jaw plain back with adaptor recess.

Model 003-204

Rear mounting.

Model 003-274

Front mounting.



Chuck Size (mm)	Through Hole	Weight each	Order Code IND-475		Price/1 TB
			003-204 Rear Mount	003-274 Front Mount	
80	16	1.51kg	-1010K	-	15965.00
80	18	1.70kg	-	-1220K	16480.00
100	20	2.98kg	-1030K	-1230K	16480.00
125	32	4.84kg	-1040K	-1240K	16995.00
160	42	9.78kg	-1060K	-1260K	17510.00
200	55	16.0kg	-1070K	-1270K	22660.00
250	76	27.9kg	-1080K	-1280K	28840.00
315	103	47.5kg	-1090K	-1290K	48410.00

Cast Iron 3 Jaw Plain Back Chuck

DIN 6350 (form A).

Three jaw plain back with adaptor recess.

Model 003-275

Front mounting, reversible jaws.



Chuck Size (mm)	Through Hole	Weight each	Order Code IND-475	Price/1 TB
125	32	5.0kg	-1450K	21630.00
160	42	10.8kg	-1460K	25235.00
200	55	17.5kg	-1470K	35020.00
250	76	29.2kg	-1480K	28480.00
315	103	50.0kg	-1490K	43106.00

Steel 3 Jaw Plain Back Chuck

DIN 6350 (form A).

Three jaw plain back with adaptor recess.

Model 003-504

Rear mounting.



Chuck Size (mm)	Through Hole	Weight each	Order Code IND-475	Price/1 TB
100	20	3.0kg	-1630K	16995.00
125	35	5.0kg	-1640K	23690.00
160	42	8.5kg	-1660K	25750.00
200	55	16.0kg	-1670K	38110.00
250	76	32.0kg	-1680K	46350.00
315	103	50.0kg	-1690K	77250.00

Lathe Chuck Jaws For Self-Centring Lathe Chucks

For self-centring lathe chucks (IND-475) - Indexa 3200 and 3500. Chuck jaws supplied in sets of three.

Hard Jaws

Fig.2

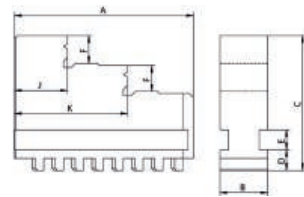

Inside

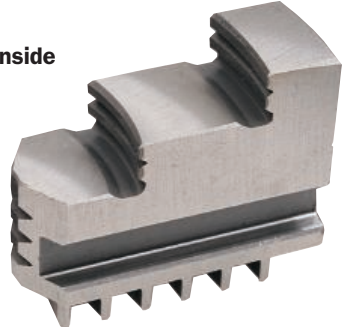

Size (mm)	Dimensions (mm)								Order Code IND-490 Inside (fig.2)	Price/1 TB
	A	B	C	D	E	F	G	H		
100	42	15	32	6	6	7	11	27	-1020K	8755.00
125	51	20	40	8	8	8	13	33.5	-1030K	10094.00
160	70	20	53	8	8	10	19	45	-1050K	11609.00
200	85	25	54	9	10	12	23	57	-1060K	13030.00
250	105	28	63	11	12	14	28	69.5	-1070K	17176.00
315	125	32	73	12.7	12	18	34.5	83	-1080K	18540.00

Lathe Chuck Keys

Supplied as standard with all Indexa lathe chucks manufactured from high quality steel, ground finish body, sliding T-bar and spring return fitted to square drive. Suitable for use with all other makes of square drive adjusting lathe chucks.



Square (AF) Size (mm)	Use With Chucks	Weight each	Order Code IND-490	Price/1 TB
11	160/200	347g	-5930K	2575.00
14	250/315	756g	-5950K	3348.00

GROUP 482 MORSE TAPER SLEEVES

KENNEDY Morse Taper Tooling
QUALITY INDUSTRIAL TOOLING



A range of quality traditional workholding equipment. Manufactured from high quality steel and case hardened all over. All sleeves and sockets are fully hardened and ground internally and externally.

ISO 238 BS 1660 : 2.

Morse Taper Sleeve Data

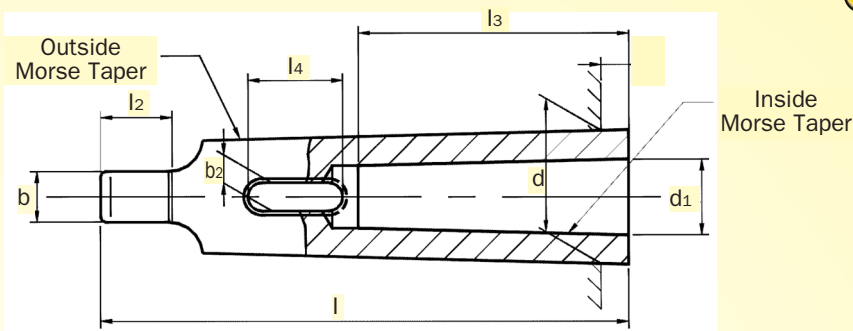

MT		l	d	b	l2	d1	l3	l4	b2
Inside	Outside								
1	2	92.00	17.780	6.350	11.112	12.065	52.388	19.050	5.410
1	3	99.00	23.825	7.938	14.288	12.065	52.388	19.050	5.410
2	3	112.00	23.825	7.938	14.288	17.780	63.500	22.225	6.604
1	4	124.00	31.267	11.906	15.875	12.065	52.388	19.050	5.410
2	4	124.00	31.267	11.906	15.875	17.780	63.500	22.225	6.604
3	4	140.00	31.267	11.906	15.875	23.825	77.788	30.162	8.179
1	5	156.00	44.399	15.875	19.050	12.065	52.388	19.050	5.410
2	5	156.00	44.399	15.875	19.050	17.780	63.500	22.225	6.604
3	5	156.00	44.399	15.875	19.050	23.825	77.788	30.162	8.179
4	5	171.00	44.399	15.875	19.050	31.267	98.425	31.750	12.141
1	6	218.00	63.348	19.050	28.575	12.065	52.388	19.050	5.410
2	6	218.00	63.348	19.050	28.575	17.780	63.500	22.225	6.604
3	6	218.00	63.348	19.050	28.575	23.825	77.788	30.162	8.179
4	6	218.00	63.348	19.050	28.575	31.267	98.425	31.750	12.141
5	6	218.00	63.348	19.050	28.575	44.399	125.412	38.100	16.129

Drill Sleeves



Taper Inside x Outside	Length (mm)	Weight each	Order Code KEN-482	Price/1 TB
1 x 2 MT	95	110g	-2120K	258.00
1 x 3 MT	97	220g	-2130K	294.00
1 x 4 MT	120	560g	-2140K	510.00
1 x 5 MT	152	1500g	-2150K	750.00
2 x 3 MT	110	200g	-2230K	303.00
2 x 4 MT	123	490g	-2240K	526.00
2 x 5 MT	155	1500g	-2250K	799.00
3 x 4 MT	140	430g	-2340K	503.00
3 x 5 MT	155	1200g	-2350K	799.00
4 x 5 MT	170	1100g	-2450K	1195.00
4 x 6 MT	215	3600g	-2460K	1783.00
5 x 6 MT	225	2800g	-2560K	1783.00

Extension Sockets



Taper Inside x Outside	Length (mm)	Weight each	Order Code KEN-482	Price/1 TB
1 x 1 MT	145	275g	-4110K	511.00
1 x 2 MT	160	290g	-4120K	547.00
2 x 1 MT	175	300g	-4210K	547.00
2 x 2 MT	175	390g	-4220K	975.00
2 x 3 MT	194	710g	-4230K	1195.00
3 x 2 MT	194	620g	-4320K	1070.00
3 x 3 MT	230	750g	-4330K	1070.00
3 x 4 MT	255	1400g	-4340K	1572.00
4 x 3 MT	255	1500g	-4430K	1572.00
4 x 5 MT	300	3000g	-4450K	2730.00
5 x 4 MT	300	2500g	-4540K	3142.00

Drill Drifts

To release Morse Taper Tooling without damaging machine socket or tools.

Drill Sleeve & Drift Set

Set of three drill sleeves 1 - 2, 2 - 3, 3 - 4 MT. Fully hardened and ground inside and out. Two drill drifts to release 1 - 2 and 3 - 4 MT.

**5
PIECES**



To Release Morse Taper	Weight each	Order Code KEN-482	Price/1 TB
0	40g	-9500K	177.00
1 & 2	80g	-9520K	190.00
3	220g	-9530K	221.00
3 & 5	380g	-9540K	246.00
5 & 6	760g	-9560K	498.00

No. of Pieces	Weight Set	Order Code KEN-482	Price/1 TB
5	995g	-9900K	1547.00

WORKSHOP EQUIPMENT



Standard Duty Revolving Centres

Manufactured from high alloy steel hardened and tempered then precision ground externally. Precision bearings are fitted as standard and the centres have a 60° point. Mounting Tapers are accurate to **DIN228** Form A, Tolerance Class AT5.

Maximum runout:
No.1 to 4 taper: 0.005mm.
No.5 to 6 taper: 0.010mm.



Morse Taper	Max rpm	Radial Load (rpm)		Axial Load (rpm)		Weight each	Order Code KEN-488	Price/1 TB
		@100 (kgf)	@max (kgf)	@100 (kgf)	@3000 (kgf)			
No.1	7000	80	32	250	50	0.37kg	-1010K	3356.00
No.2	7000	200	55	275	60	0.43kg	-1020K	5490.00
No.3	6000	300	70	400	70	0.67kg	-1030K	6406.00
No.4	5000	600	75	500	125	1.23kg	-1040K	8846.00
No.5	4000	800	280	570	230	3.00kg	-1050K	12811.00

Heavy Duty Revolving Centres

Manufactured from high alloy steel, heat treated and precision ground. Fitted with heavy duty precision taper roller and thrust bearings to support both radial and axial loads. The 60° point is ground after assembly for absolute concentricity. Designed for heavy load and high production applications where durability is the main criteria. Mounting Tapers are accurate to **DIN228** Form A, Tolerance Class AT5.

Maximum runout:
No.2 to 5 taper: 0.005mm.
No.6 taper: 0.010mm.



Morse Taper	Max rpm	Radial Load (rpm)		Axial Load (rpm)		Weight each	Order Code IND-488	Price/1 TB
		@100 (kgf)	@max (kgf)	@100 (kgf)	@3000 (kgf)			
No.1	5000	35	10	190	50	0.25kg	-2010K	5411.00
No.2	5000	85	20	350	100	0.35kg	-2020K	9013.00
No.3	4000	175	50	700	200	0.92kg	-2030K	9269.00
No.4	3000	350	125	700	200	1.45kg	-2040K	12875.00
No.5	2500	800	350	1200	500 ⁽¹⁾	3.55kg	-2050K	16995.00
No.6	2000	1250	600	3000	1000 ⁽²⁾	11.40kg	-2060K	46350.00

⁽¹⁾@2500rpm; ⁽²⁾@2000rpm

Industrial Solid Centres

Manufactured from high quality tool steel, hardened and ground with 60° point and spanner flats as standard. Mounting Tapers are accurate to **DIN228** Form A, Tolerance Class AT5.



Morse Taper	Diameter (mm)	Across Flats	Length (mm)	Weight each	Order Code KEN-487	Price/1 TB
No.1	12.20	10	78	60g	-1010K	335.00
No.2	18.00	13	90	200g	-1020K	282.00
No.3	24.10	19	138	300g	-1030K	428.00
No.4	31.60	24	138	450g	-1040K	720.00



Standard Duty Revolving Centres

Manufactured from high alloy steel hardened and tempered then precision ground externally. Precision bearings are fitted as standard and the centres have a 60° point.

Maximum runout: 0.005mm.

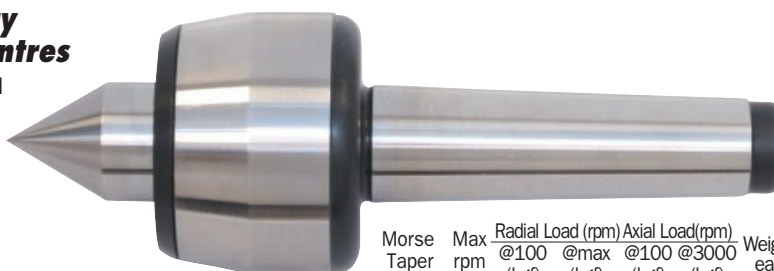

REVOLVING & SOLID CENTRES

Standard Duty Interchangeable Revolving Centre Sets

Manufactured from high alloy steel, precision ground internally and externally with pre-lubricated bearings. A versatile revolving centre with interchangeable points for a wide variety of applications. Ideal for toolroom or manufacture of small turned components. Points fit into body by means of a taper and are removed by use of the drift key supplied. All mating surfaces are precision ground and the set is supplied in a varnished wooden storage box.



Morse Taper	Axial Load at 100rpm	Radial Load at 100rpm	Max rpm	Max Runout
No. 2	200Kgf	100Kgf	4000	0.005mm
No. 3	400Kgf	200Kgf	3000	0.005mm

Morse Taper	Length (mm)	Diameter (mm)	Weight each	Order Code KEN-488	Price/1 TB
No.2	124	33	0.85kg	-1320K	15965.00
No.3	152	42	1.10kg	-1330K	14935.00

Interchangeable Points

A complete range of interchangeable points to complement the revolving centre sets.

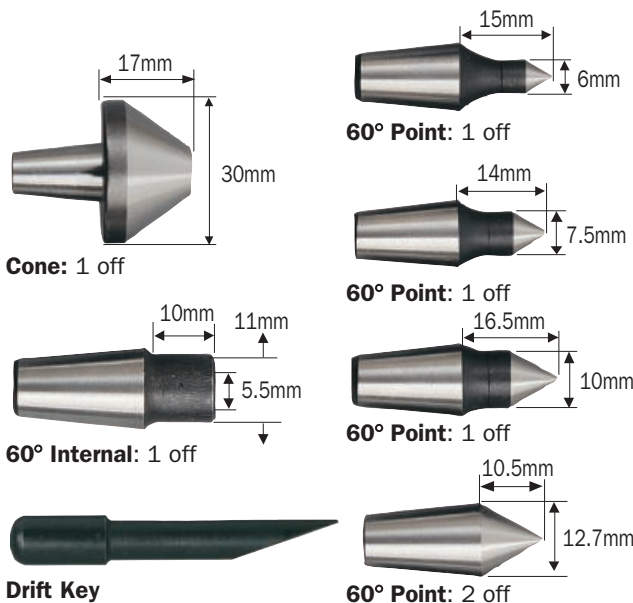

Description	Weight each	Order Code KEN-489	Price/1 TB
60° Point x 6mm Dia.	20g	-1020K	1776.00
60° Point x 7.5mm Dia.	20g	-1030K	1776.00
60° Point x 10mm Dia.	25g	-1040K	670.00
60° Point x 12.7mm Dia.	20g	-1050K	773.00

GROUP 490 LATHE CHUCK JAWS

KENNEDY *Scroll Jaws*
 QUALITY INDUSTRIAL TOOLING

To Suit Pratt Burnard Chucks
 For Standard, Super Precision, Griptru.
 All steel (type 78), Pratt Burnard old type
 (Inch) and Hardinge chucks.

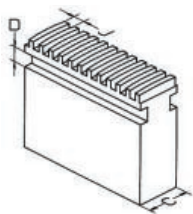

Chuck Type	Jaw Code (Refer to Diameter)
Standard, Griptru, Super Precision	B, C, E, G, J, M, P, Q, R
All Steel (Type 78)	L, O
Burnard	I, K, N
Pratt Old Type	H
Hardinge/Pratt Type	F

3 Jaw Sets



4 and 6 jaw sets available on request

Jaw Code	Dimensions (mm)				Order Code KEN-490	Price/1 TB
	Chuck Diameter	C	D	J		
EJC	100mm	14.10	4.85	5.08	-1030K	2725.00
EJE	125mm	15.75	8.03	6.35	-1050K	2725.00
EJF	125mm	14.10	4.85	6.35	-1060K	3258.00
EJG	160mm	18.79	8.03	6.35	-1070K	2962.00
EJJ	200mm	20.62	9.53	8.46	-1100K	3258.00
EJL	230mm	25.40	9.52	8.46	-1120K	5627.00
EJM	250mm	25.40	11.10	8.46	-1130K	13390.00
EJP	315mm	28.19	12.88	8.46	-1160K	6335.00

Serrated Soft Jaws

To suit metric serrated power chucks (Kitagawa/Howa/Matsumoto/Pratt Burnard/SMW/Autoblok etc.).

3 Jaw Sets

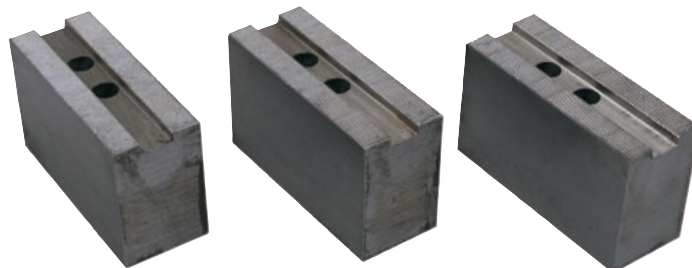
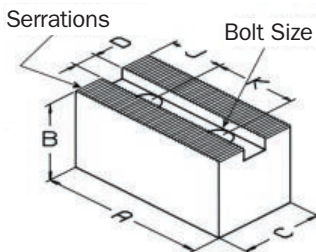

Jaw Code	Chuck Diameter	Dimensions (mm)				K/J Bolt	Serrations	Order Code KEN-490	Price/1 TB
		A	B	C	D				
BO06	165mm	72	38	32	12	20/15/M10	1.5mm x 60	-5560K	2139.00
DJ06	165mm	72	57	32	12	20/15/M10	1.5mm x 60	-5860K	3196.00
PT06	165mm	82	32	32	12	20/15/M10	1.5mm x 60	-2060K	2962.00
BO08	210mm	95	44	32	14	25/25/M12	1.5mm x 60	-5580K	2305.00
DJ08	210mm	95	70	32	14	25/25/M12	1.5mm x 60	-5880K	3974.00
PT08	210mm	102	44	32	14	25/20/M12	1.5mm x 60	-2080K	3672.00
BO10	254mm	110	40	40	16	30/30/M12	1.5mm x 60	-5600K	2526.00
DJ10	254mm	110	80	40	16	30/30/M12	1.5mm x 60	-5900K	4527.00
DK10	254mm	90	60	40	16	30/21/M12	1.5mm x 60	-5970K	3851.00
PT10	254mm	125	40	40	16	30/30/M12	1.5mm x 60	-2100K	3672.00
DK11	254mm	110	60	40	16	30/21/M12	1.5mm x 60	-5980K	6812.00
BO12	315mm	130	50	50	18	30/40/M14	1.5mm x 60	-5620K	3554.00
DJ12	315mm	130	80	50	18	30/40/M14	1.5mm x 60	-5920K	7219.00
BR13	315mm	130	50	50	21	30/40/M16	1.5mm x 60	-5700K	4378.00
DJ13	315mm	130	80	50	21	30/40/M16	1.5mm x 60	-5930K	7928.00
BO15	380mm	165	76	64	22	43/37/M20	1.5mm x 60	-5650K	8993.00
DJ15	380mm	165	127	64	22	43/37/M20	1.5mm x 60	-5950K	16392.00
BO18	454/530/610mm	180	76	64	25	60/40/M20	3.0mm x 60	-5660K	12875.00

Serrated Soft Jaws

To suit inch serrated power chucks (Berg/Forkardt/Rohm/Pratt Burnard/SMW/Autoblok etc.).

3 Piece Set

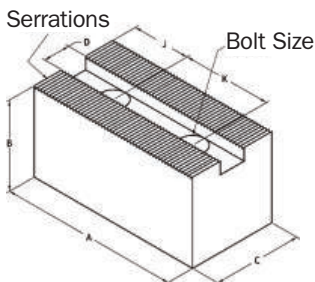

Jaw Code	Chuck Diameter	Dimensions (mm)				K/J Bolt	Serrations	Order Code KEN-490	Price/1 TB
		A	B	C	D				
BN90	165/200mm	90	60	40	17.0	22/15/M12	1/16" x 90	-5090K	2960.00
BN12	250/315mm	120	80	50	21.0	28/20/M16	1/16" x 90	-5120K	4615.00
BN23	400/500/630mm	155	89	64	25.5	35/30/M20	3/32" x 90	-5230K	9476.00

Scroll Jaws

To suit Pratt Burnard metric chucks (Standard Accuracy and Super Precision).

3 Jaw Sets

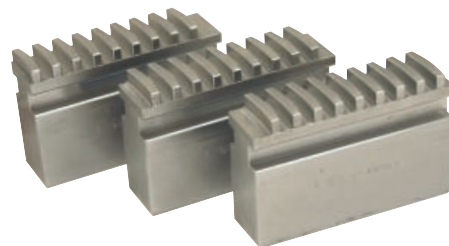

4 and 6 jaw sets available on request

Jaw Code	Dimensions (mm)			Order Code KEN-490	Price/1 TB
	Chuck Diameter	C	D		
EK16	160mm	18	7	6	-6030K 3140.00
EK20	200mm	22	8	8	-6040K 3258.00
EK25	250mm	25	8	8	-6050K 4680.00
EK32	315mm	32	12	10	-6060K 6695.00

Soft Scroll Jaws

To suit Indexa/Bison chucks.

3 Jaw Sets



Jaw Code	Dimensions (mm)			Order Code KEN-490	Price/1 TB
	Chuck Diameter	C	D		
EN08	80mm	11	6	4	-6180K 5665.00
EN10	100mm	15	6	6	-6200K 4635.00
EN13	125mm	20	8	7	-6220K 4738.00
EN16	160mm	20	8	8	-6230K 4841.00
EN20	200mm	25	10	8	-6240K 4944.00
EN25	250mm	28	12	9	-6250K 5331.00
EN32	315mm	32	12	10	-6260K 6515.00





KENNEDY *Huntington Type Wheel Dressers*
QUALITY INDUSTRIAL TOOLING

With improved quick release cutter wheel design which reduces down-time when changing wheels. Ergonomically designed cast iron handle and case hardened, polished cutters. Suitable for cleaning, sharpening and truing grinding wheels.



Type	For Wheel Diameter	Weight each	Order Code KEN-495	Price/1 TB
No.0	Up to 510mm (20")	0.85kg	-0100K	1130.00
No.1	Up to 760mm (30")	1.00kg	-0110K	1448.00
No.2	Over 760mm (30")	2.50kg	-0120K	1984.00



Replacement Wheel Sets



Description	Weight per 10 Sets	Order Code KEN-495	Price/1 TB
Spare Wheels for Type No.0	0.45kg	-1000K	169.00
Spare Wheels for Type No.1	0.53kg	-1010K	192.00
Spare Wheels for Type No.2	2.90kg	-1020K	435.00

Replacement Parts

Description	Weight per 10	Order Code KEN-495	Price/1 TB
Side Bush for Type No.0	79g	-2000K	629.00
Cutter Bush for Type No.1	110g	-2010K	670.00
Cutter Bush for Type No.2	234g	-2020K	759.00
Spare Spindle for Type No.0	130g	-3000K	331.00
Spare Spindle for Type No.1	310g	-3010K	840.00
Spare Spindle for Type No.2	310g	-3020K	1010.00
Side Washer for Type No.1	70g	-4010K	504.00
Side Washer for Type No.2	50g	-4020K	670.00

KENNEDY *Diamond Point Wheel Dressing Tools*
QUALITY INDUSTRIAL TOOLING

Single-Point Tools

For general use. The diamond point can be reset when it 'flats', giving extended tool life (resetting prices available on request). 1/2" x 6" holder size.



Product Number	Diamond Size, Carat	For use on Wheel	Weight each	Order Code KEN-496	Price/1 TB
SP50	0.50	180mm (7")	160g	-0050K	1190.00
SP75	0.75	255mm (10")	160g	-0070K	1830.00
SP100	1.00	355mm (14")	170g	-0100K	2562.00
SP150	1.50	460mm (18")	170g	-0150K	3660.00
SP200	2.00	600mm (24")	170g	-0200K	4941.00

Chisel-Point Tools

Designed for dressing formed wheels. Similar to single point tools but more robust and no resetting required. 3/8" x 3" holder size.



Product Number	Included Angle	Nose Radius	Weight each	Order Code KEN-496	Price/1 TB
D605		0.005"	160g	-1000K	6438.00
D405		0.005"	170g	-1100K	6438.00

SENATOR *Diamond Dressers*
QUALITY TOOLING

For truing and dressing grinding wheels. Truing is the process of aligning the periphery of the grinding wheel so that it runs concentric with its axis of rotation. This allows accurate and precise relative motion between the grinding wheel and the part being ground. Dressing removes dulled abrasives and foreign material that has been embedded into the wheel. This allows the wheel to cut properly. These tools are mainly used to true straight-faced wheels.

3 Piece Set

For medium duty use. 1/2" dia. x 6" (-9100K).



Wheel Size (mm)	Carat Size	Weight each	Order Code SEN-496	Price/1 TB
Up to 150	0.25	149g	-0250K	684.00
Up to 180	0.50	150g	-0500K	804.00
Up to 250	0.75	150g	-0750K	1149.00
Up to 350	1.00	151g	-1000K	1367.00
Up to 500	1.50	149g	-1500K	2163.00
Up to 600	2.00	150g	-2000K	2833.00
3 Piece Set 0.5, 0.75 & 1 Carat Set				-9100K 3605.00

GROUP 501 ADJUSTABLE WRENCHES

Page ... **322 - 324**

GROUP 503 AUTOMOTIVE

Page ... **325 - 350**

GROUP 505 COLD CHISELS & PRY BARS

Page ... **351 - 353**

GROUP 510 SPIRIT/LASER LEVELS

Page ... **354**

GROUP 512 PLASTERING/BRICK TOOLS

Page ... **355 - 357**

GROUP 515 CRIMPING TOOLS

Page ... **358 - 362**

GROUP 516 CABLE/WIRE STRIPPING TOOLS

Page ... **363 - 365**

GROUP 516 SOLDERING TOOLS

Page ... **366 - 368**

GROUP 516 MULTIMETERS

Page ... **369 - 372**

GROUP 518 ENGINEER'S HAND TOOLS

Page ... **373 - 385**

GROUP 522 GARDENING & CONTRACTOR'S TOOLS

Page ... **386 - 391**

GROUP 523 GARDEN WATERING PRODUCTS

Page ... **392 - 397**

GROUP 525 HAMMERS & AXES

Page ... **399 - 403**

GROUP 527 INSERTED FACE HAMMERS

Page ... **404 - 406**

GROUP 530 HAMMER SHAFTS

Page ... **407**

GROUP 531 FILE HANDLES

Page ... **407**

GROUP 533 SCISSORS & DECORATING TOOLS

Page ... **408 - 417**

GROUP 534 INSULATED SERVICE TOOLS

Page ... **418**

GROUP 536 TAPE MEASURES

Page ... **422 - 423**

GROUP 537 KNIVES

Page ... **424 - 429**

GROUP 538 SAW FRAMES

Page ... **430 - 431**

GROUP 539 CLAMPS

Page ... **432 - 435**

GROUP 540 FLUID HANDLING & LUBRICATION

Page ... **436 - 441**

GROUP 549 SHEET METAL WORKING TOOLS

Page ... **402**

GROUP 553 MAGNETIC TOOLING

Page ... **442 - 444**

GROUP 555 TORQUE TOOLS

Page ... **445 - 447**

GROUP 556 NUT SPINNERS

Page ... **447**

GROUP 558 PLIERS & GRIPS

Page ... **448 - 463**

GROUP 560 PUNCHES & STAMPS

Page ... **464 - 465**

GROUP 561 STENCILS

Page ... **465**

GROUP 569 RIVETING TOOLS

Page ... **466 - 467**

GROUP 572 SCREWDRIVERS

Page ... **468 - 477**

GROUP 573 SCREWDRIVER BITS

Page ... **478 - 485**

GROUP 575 SAFETY TOOLS

Page ... **486 - 490**

GROUP 580 WORKSHOP SPANNERS & SCAFFOLDING TOOLS

Page ... **491 - 492**

GROUP 582 SPANNERS & SOCKETS

Page ... **493 - 507**

GROUP 583 IMPACT SOCKETS

Page ... **508 - 543**

GROUP 588 PIPE TOOLS

Page ... **544 - 550**

GROUP 589 VICE GRIPS

Page ... **551**

GROUP 591 SHEARS & SNIPS

Page ... **552 - 554**

GROUP 592 BOLT & CABLE CUTTERS

Page ... **554**

GROUP 593 DRAWER CABINETS

Page ... **555**

GROUP 593 TOOL POUCHES & TOOL ROLLS

Page ... **556 - 559**

GROUP 593 TOOL BAGS, CASES & BOXES

Page ... **560 - 571**

GROUP 594 ROLLER CABINETS & TOOL CHESTS

Page ... **572 - 583**

GROUP 595 TOOL KITS & TOOL CONTROL

Page ... **584 - 595**

GROUP 597 WOODWORKING TOOLS

Page ... **597 - 605**

GROUP 601 HEXAGON KEYS

Page ... **606 - 607**

GROUP 602 HEXAGON BALL DRIVERS

Page ... **608 - 610**

GROUP 603 TX KEYS

Page ... **611**



HAND TOOLS

**Product Groups
501 - 603**

Product Grading



Production

High performance industrial tooling designed for continuous use applications on machine tools where repeatability and long tool life are of critical importance.



Professional

Industrial tooling that has enhanced features and benefits demanded by craftsmen and professional users.



Industrial

Designed for regular use in industrial applications. Manufactured to stringent quality levels and international standards.



Workshop

Standard quality tooling for use by tradesmen and generally industrial use.



Maintenance

Products designed for general maintenance of machines, workshops, garages and some household applications.



Home Improver

DIY quality tooling. Designed for home use and light industrial applications.

Contents

Description	Group	Page
Adjustable Wrenches	501	322 - 324
Automotive Tools	503	325 - 350
Basin Wrenches	588	549
Bolt Cutters	592	554
Cable Ties	515	363
Chain Separators	588	549
Clamps	539	432 - 435
Cold Chisels & Pry Bars	505	351 - 353
Contractor's Tools	522	389 - 391
Crimping Tools	515	358 - 361
Cycle Tools	595	596
Drawer Cabinets	593	555
Engineer's Hand Tools	518	373 - 385
File Handles	531	407
Fluid Handling	540	436 - 438
Garden Tools	522	386 - 388
Garden Watering Products	523	392 - 395
Garden Bags	523	396
Garden Gazebo & Fencing	523/984	397
Grease Nipples	541	442
Hammers & Axes	525	398 - 403
Hammer Shafts & Wedges	530	407
Hexagon Keys	601	606 - 607
Hexagon Ball Drivers	602	608 - 610
Impact Sockets	583	536 - 543
Insulated Service Tools	534	418 - 421
Knives	537	424 - 429
Lubrication Equipment	540	439 - 441
Magnetic Cable Guider	516	363
Magnetic Tooling	553/554	443 - 444
Mains Testers	515	363
Multimeters & Voltage Detectors	516	368 - 372
Nut Spinners	556	447
Painting & Decorating Tools	533	408 - 415
Pipe Tools	588	544 - 549
Plastering Tools & Trowels	512	355
Pliers & Grips	558	448 - 463
Precision Knives & Blades	537	428
Punches & Stamps	560	464 - 465
Riveting Tools	569	466 - 467
Roller Cabinets & Tool Chests	594	572 - 583
Roller Stands	588	551
Safety Tools	575	486 - 490
Saw Frames	538	430 - 431
Scaffolding Tools	580	492
Scissors	533	416 - 417
Screwdriver Bits	573	478 - 485
Screwdrivers	572	468 - 477
Shears & Snips	591	552 - 553
Sockets & Accessories	- 1/4" Square Drive	510 - 511
	- 3/8" Square Drive	512 - 515
	- 1/2" Square Drive	516 - 520
	- 3/4" Square Drive	521
	- 1" Square Drive	522
Socket Sets	- Mixed Drive	582
	- 1/4" Square Drive	524 - 525
	- 3/8" Square Drive	526 - 527
	- 1/2" Square Drive	528 - 530
	- 3/4" Square Drive	530 - 535
	- 1" Square Drive	535
		525
Socket Storage Rails & Clips	582	523
Soft Faced Hammers	527	406
Soldering Tools	516	366 - 368
Spanners	581/582	493 - 506
Spirit Levels	510	354
Stencils	561	465
Strap Wrenches	582	507
Tape Measures	536	422 - 423
Tiling Tools	533	415
Tool Cases	593	562 - 566
Bags		560 - 561
Boxes		567 - 571
Pouches		556 - 558
Rolls		559
Tool Kits	595	586 - 595
Torque Tools	555	445 - 447
TX Keys	603	611
Vice Jaws	589	551
Wire Stripping Tools	516	363 - 365
Woodworking Tools	597	597 - 605

GROUP 501 ADJUSTABLE WRENCHES

KENNEDY PROFESSIONAL

Cushion Grip Adjustable Wrenches

Drop forged chrome vanadium steel with phosphate anti-corrosion finish. Hardened parallel opening jaws are ground and polished, laser etched with metric graduations for rapid repeatable reference setting. The wide grooved profile of the opening mechanism and coarsely knurled adjusting screw ensures smooth adjustment. Slim head profile allows easy access, the contoured jaws improve grip when used on damaged misshaped fasteners. The unique geometric cushion grip improves user comfort, is resistant to oil and grease to provide a slip free grip. Securely bonded to the I-beam handle sub frame to prevent the ingress of oil and dirt.

Conforms to: **BS 6333-1995, DIN3117-1988.**



Tapered Jaw For Access Into Tight Spaces.



Kennedy Professional 150mm Wrench
Jaw capacity: 24mm

UP TO 20% GREATER JAW CAPACITY THAN CONVENTIONAL ADJUSTABLE WRENCHES

Conventional 150mm Wrench
Jaw capacity: 20mm

HAND TOOLS



GROOVED JAW FOR POSITIVE GRIP EVEN ON WORN SURFACES

Length (mm)	Jaw Opening	Fastener Range	Weight each	Order Code KEN-501	Price/1 TB
150 (6")	23.9mm	M2-M14 (1/8" - 9/16")	140g	-3060K	794.00
200 (8")	28.6mm	M4-M18 (3/16" - 5/8")	260g	-3080K	1012.00
250 (10")	32.8mm	M6-M20 (1/4" - 3/4")	400g	-3100K	1274.00
300 (12")	38.1mm	M8-M24 (5/16" - 1")	650g	-3120K	1586.00

Twin Pack

2 PIECES



Contents	Weight each	Order Code KEN-501	Price/1 TB
200 & 300mm	800g	-0640K	2077.00

KENNEDY QUALITY INDUSTRIAL TOOLING **Extra Wide Jaw Adjustable Wrench**

Drop forged chrome vanadium steel. Rubber comfort grip handle. Ideal for use in plumbing, installation and automotive applications. Ultra thin head designed for use in confined spaces. Graduated millimetre scale. More than 50% wider jaw compared to conventional adjustable wrenches.

Conforms to: **ISO 6787-1982, ASME B.107.8M-1996, BS 6333-1995, DIN3117-1988, JIS B4604-1976.**



Length (mm)	Jaw Opening (mm)	Weight each	Order Code KEN-501	Price/1 TB
150 (6")	34.0	176g	-5060K	821.00
200 (8")	38.0	315g	-5080K	931.00
250 (10")	50.0	554g	-5100K	1040.00
300 (12")	60.0	868g	-5120K	1545.00

Combi Grip Adjustable Wrenches

These wrenches have a quick release reversible lower jaw with a serrated side with extra hard teeth for pipe gripping, a strong handle and a phosphated corrosion resistant finish. The smooth adjusting action makes them fast and easy to use. Conform to: **ISO 6787-1982, ASME B.107.8M-1996, BS 6333-1995, DIN 3117-1988, JIS B4604-1976.**



Length (mm)	Jaw Opening (mm)	Weight each	Order Code KEN-501	Price/1 TB
250 (10")	30.0	345g	-4100K	1296.00
300 (12")	35.0	890g	-4120K	1635.00

KENNEDY Adjustable Wrenches
QUALITY INDUSTRIAL TOOLING

Manufactured from high strength 1' beam section chrome or phosphate vanadium steel for improved strength and rigidity, the jaws are heat treated for extended tool life. High polished corrosion-resistant finish. 15° offset head angle for positive torque control. Slimline tapered jaws for improved access into confined spaces. Parallel jaws with smooth jaw adjustment and self-locking design prevents the jaws opening unintentionally even when under full load. Suitable for industrial engineering, automotive, agricultural, maintenance and assembly applications.

Conforms to: **BS 6333-1995, DIN3117-1988.**

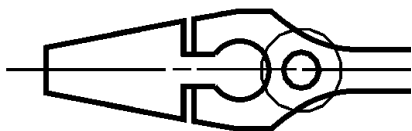

Tapered Jaw For Access Into Tight Spaces



Phosphate Finish

Phosphate Finish

UP TO 20% GREATER JAW CAPACITY THAN CONVENTIONAL ADJUSTABLE WRENCHES

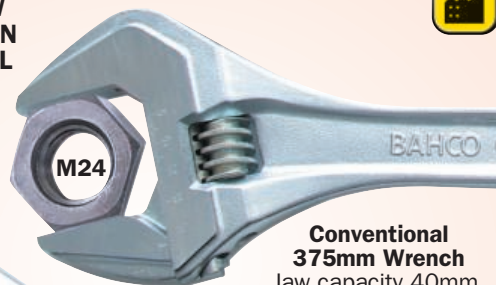

Conventional 375mm Wrench
Jaw capacity 40mm.

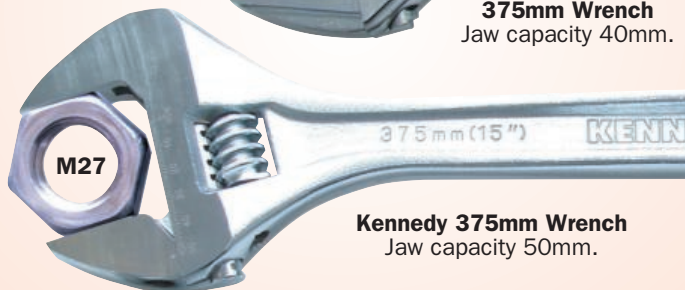

Kennedy 375mm Wrench
Jaw capacity 50mm.

Phosphate Finish

Length (mm)	Jaw Opening (mm)	Torque (kg/cm)	Weight each	Order Code KEN-501	Price/1 TB
100 (4")	17 (21/32")	714	60g	-0040K	550.00
150 (6")	24 (1")	1670	140g	-0060K	575.00
200 (8")	28 (1 3/32")	3100	260g	-0080K	755.00
250 (10")	33 (1 5/16")	5190	400g	-0100K	931.00
300 (12")	38 (1 3/8")	8820	650g	-0120K	1176.00
375 (15")	50 (2")	17295	1040g	-0150K	2509.00
450 (18")	60 (2 3/8")	23060	1670g	-0180K	4400.00
600 (24")	70 (2 3/4")	25000	3300g	-0240K	8689.00

Chrome Finish

Length (mm)	Jaw Opening (mm)	Torque (kg/cm)	Weight each	Order Code KEN-501	Price/1 TB
100 (4")	17 (21/32")	714	60g	-1040K	476.00
150 (6")	24 (1")	1670	140g	-1060K	520.00
200 (8")	28 (1 3/32")	3100	260g	-1080K	684.00
250 (10")	33 (1 5/16")	5190	400g	-1100K	903.00
300 (12")	38 (1 3/8")	8820	650g	-1120K	1176.00
375 (15")	50 (2")	17295	1040g	-1150K	2171.00
450 (18")	60 (2 3/8")	23060	1670g	-1180K	3373.00

Phosphate Finish Sets

2 PIECES **3** PIECES

Chrome Finish Set

3 PIECES



Number of Pieces	Contents	Weight each	Order Code KEN-501	Price/1 TB
3	100, 200 & 300mm	1100g	-0600K	2242.00
2	150 & 250mm	540g	-0620K	1258.00

Number of Pieces	Contents	Weight each	Order Code KEN-501	Price/1 TB
3	100, 200 & 300mm	1100g	-1600K	2242.00

PRODUCTS ARE ONLY AVAILABLE VIA YOUR DISTRIBUTOR

HAND TOOLS

GROUP 501 ADJUSTABLE WRENCHES

YAMOTO *Satin Finish Adjustable Wrenches*



Slimline tapered parallel jaws for improved access into confined spaces with smooth jaw adjustment and self-locking design prevents the jaws opening unintentionally even when under full load. Graduated laser etched jaws for fast repeatable jaw setting and adjustment. Manufactured from 1" beam section chrome vanadium steel for improved strength and rigidity, the jaws are heat treated for extended tool life. Corrosion-resistant satin finish. 22.5° offset head angle for positive torque control. Suitable for marine engineering, automotive, aerospace, agricultural maintenance and assembly applications. Conforms to: **BS 6333-1995, DIN3117-1988.**



Torque Ratings
Conform to ISO 6787:1982.

Length (mm)	Jaw Opening (mm)	Torque kg/cm	Weight each	Order Code YMT-501	Price/1 TB
150 (6")	20 (3/4")	1670	140g	-2060K	594.00
200 (8")	25 (1")	3100	260g	-2080K	752.00
250 (10")	30 (1 3/16")	5190	400g	-2100K	948.00
300 (12")	35 (1 3/8")	8820	650g	-2120K	1166.00
375 (15")	44 (1 3/4")	17295	950g	-2150K	2290.00



Sets	Number of Pieces	Contents	Weight each	Order Code YMT-501	Price/1 TB
	2	150 & 250mm	650g	-2400K	1572.00
	2	200 & 300mm	1020g	-2500K	1949.00

HAND TOOLS

SENATOR *Chrome Finish Adjustable Wrenches*

Manufactured from 1" beam section chrome vanadium steel for improved strength and rigidity, the jaws are heat treated for extended tool life. High polished corrosion-resistant chrome finish. 22.5° offset head angle for positive torque control. Slimline tapered jaws for improved access into confined spaces. Parallel jaws with smooth jaw adjustment and self-locking design prevents the jaws opening unintentionally even when under full load. Suitable for industrial engineering, automotive, aerospace, maintenance and assembly applications.



EXTENDED RANGE

Torque Ratings
Conform to: ISO 6787:1982.

Length (mm)	Torque kg/cm	Weight each	Order Code SEN-501	Price/1 TB
100 (4")	690	60g	-1040K	379.00
150 (6")	1670	140g	-1060K	379.00
200 (8")	3100	260g	-1080K	503.00
250 (10")	5190	400g	-1100K	604.00
300 (12")	8820	650g	-1120K	846.00
380 (15")	17295	1300g	-1150K	1709.00
457 (18")	23060	1990g	-1180K	2965.00
612 (24")	28807	3400g	-1240K	3605.00

Chromed Drop Forged Adjustable Wrenches

Tapered jaws for improved access into confined spaces. Smooth jaw adjustment. Graduated laser etched jaw for fast jaw setting. Manufactured from chromed drop forged steel.



EXTENDED RANGE

Size	Jaw Opening	Weight each	Order Code SEN-501	Price/1 TB
150mm (6")	20mm	140g	-4060K	220.00
200mm (8")	24mm	280g	-4080K	260.00
250mm (10")	30mm	435g	-4100K	382.00
300mm (12")	34mm	720g	-4120K	446.00
778mm (30")	93mm	5800g	-1300K	6695.00

Chromed Drop Forged General-Purpose Wrench

Made from fully chrome plated drop forged steel. Jaw opening capacity 68mm. 90° sliding jaw.

Overall length: 230mm.

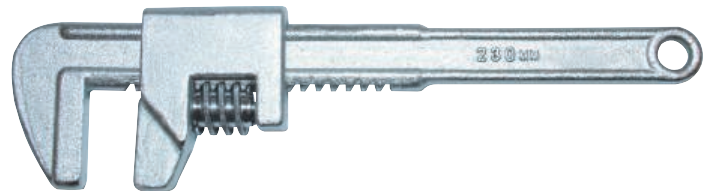

Length (mm)	Jaw Opening (mm)	Weight each	Order Code SEN-501	Price/1 TB
230 (9")	68	500g	-5100K	847.00

KENNEDY *Service Kits*

Consisting of replacement jaw, knurl and pin.



Finish	Wrench Size (mm)	Weight each	Order Code KEN-567	Price/1 TB
Phosphate	150 (6")	25g	-0060K	258.00
	200 (8")	55g	-0080K	284.00
	250 (10")	90g	-0100K	361.00
	300 (12")	130g	-0120K	531.00
	375 (15")	250g	-0150K	585.00
	450 (18")	365g	-0180K	691.00
Chrome	600 (24")	420g	-0240K	2575.00
	150 (6")	25g	-1060K	531.00
	200 (8")	55g	-1080K	585.00
	250 (10")	90g	-1100K	691.00
	300 (12")	130g	-1120K	797.00
	375 (15")	250g	-1150K	903.00
	450 (18")	365g	-1180K	1009.00
	600 (24")	420g	-1240K	2555.00

AUTOMOTIVE - BATTERY & ELECTRICAL SYSTEM TOOLS



Circuit Continuity Tester

For testing circuit continuity on non-live systems. Locates broken circuits in fuses, switches, sockets and wires. 1m lead. Super sharp tempered steel probe to test through wire insulation.

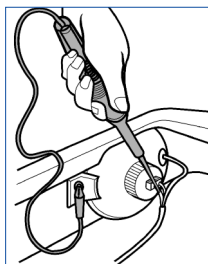

45mm		210mm	
Requires AA battery (not supplied).			
Model Number	Weight each	Order Code KEN-503	Price/1 TB
CCT001	90g	-1000K	411.00

Standard Circuit Tester

Suitable for use with power on. For 6 and 12V automotive systems only. Locates shorts, earth and open circuits. 1m lead. Super sharp tempered steel probe to test through wire insulation.

Probe length: 45mm.

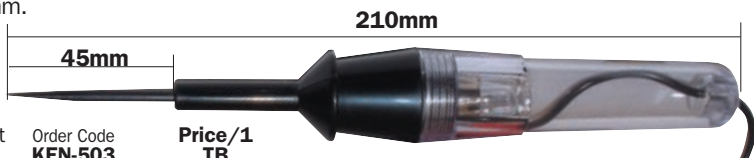

Model Number	Weight each	Order Code KEN-503	Price/1 TB
SCT012	80g	-1020K	308.00

For use on 6 and 12V

Commercial Duty Circuit Tester

Suitable for use with power on. For 6, 12 and 24V automotive systems only. Locates shorts, earths and open circuits. 1.4m heavy duty lead with spring strain relief. Super sharp stainless steel probe to test through wire insulation.

Probe length: 100mm.

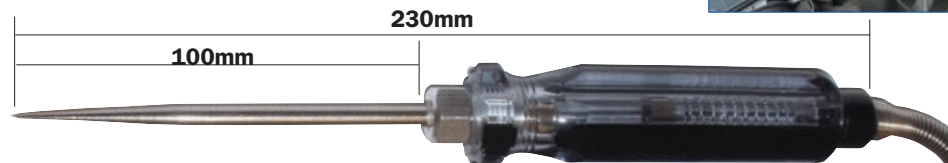

Model Number	Weight each	Order Code KEN-503	Price/1 TB
CDT024	215g	-1060K	716.00

For use on 6, 12 and 24V

Long Probe Circuit Tester

Suitable for use with power on. For 6 and 12V automotive systems only. Locates shorts, earth and open circuits. 1.7m heavy duty lead with spring strain relief. Super sharp tempered steel probe to test through wire insulation.

Extra long probe length: 180mm.



Model Number	Weight each	Order Code KEN-503	Price/1 TB
XCT012	245g	-1040K	850.00

For use on 6 and 12V

Battery Fluid Tester

Tests 6, 12 and 24V batteries. Tough glass tube construction with colour coded float for easy reading which indicates the state of charge in each cell. Displays the specific gravity with a scale range of 1.100 to 1.300.



Product Number	Scale Range	Order Code KEN-503	Price/1 TB
BFT624	1.1-1.3	-1120K	799.00

Battery & Alternator Tester

Indicates condition of battery and the output of an alternator. For automotive use on 12V DC systems only. Magnetic back.



0.8m long cable leads.



Test Voltage	Cable Length	Order Code KEN-503	Price/1 TB
12V	0.8m	-1080K	763.00

Standard Automotive Fuse Set

An assortment of standard automotive bladed fuses supplied in transparent storage box. Colour coded transparent fuse bodies. Rated to 32V.

Fuse material: zinc.

Contents:

Plug-in fuse type: 3A, 5A, 7.5A, 15A, 20A, 30A (15 of each).

Plug-in fuse type: 10A (30pcs).

**120
PIECES**



Number of Pieces	Order Code KEN-503	Price/1 TB
120	-9900K	766.00

High Amp Maxi Fuse Set

An assortment of Maxi (High Amp) automotive bladed fuses supplied in a transparent storage case. Colour coded transparent fuse bodies.

Fuse voltage rating: 32V.

Fuse material: Zinc.

Contents:

Fuse types: 20A, 30A, 40A, 50A, 60A, 70A, 80A, 100A (6 of each).

**48
PIECES**



Number of Pieces	Order Code KEN-503	Price/1 TB
48	-9920K	3006.00

Quick Splice Set

For fast, simple and strong splicing of automotive electrical wires. Easy-to-use, no wire strippers or crimper required.

Maximum electrical rating: 600V.

Maximum temperature: 105°C.

Terminal material: brass.

Plating: tin insulation. Material: PP.

Contents:
Red: 0.5mm² x 1.0mm² (25pcs).
Blue: 1.5mm² x 2.5mm² (25pcs).

**50
PIECES**



Number of Pieces	Order Code KEN-503	Price/1 TB
50	-9930K	603.00

PRODUCTS ARE ONLY AVAILABLE VIA YOUR DISTRIBUTOR

HAND TOOLS

KENNEDY 7-Piece Panel Beating Set
QUALITY INDUSTRIAL TOOLING

Supplied in a high quality fitted blow moulded impact resistant case. Drop forged, high carbon steel hammers with ground heads and cheeks. Hickory, octagonal section shafts. 1x: curved, utility, heel and toe dolly. 1x: 12oz shrinking hammer and flat faced bumping hammer, 1x 10oz round finishing pick.

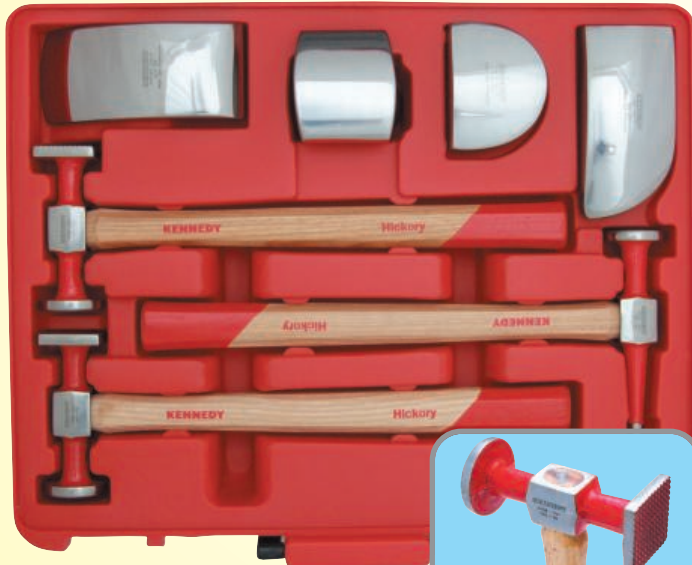

**7
PIECES**



Group 525

Number of Pieces	Weight each	Order Code KEN-503	Price/1 TB
7	7.40kg	-7650K	7754.00

Dent Puller Set

For repairing dents in body panels. Supplied complete with self tapping pull screw for use where access to the rear of the panel is blocked by reinforcements or other parts, a range of steel hooks and pull curls for pulling the edges of panels and a chain and hook. The long hammer shaft allows the pulling/striking force to be precisely controlled.

Contents: (1x) hammer (10lbs cast iron), 22.5Ø x 500 and 22.5Ø x 200mm pipes, 2 hole pipes, 6 x 170, 6 x 120, 6 x 200 and 3mm x 100mm plates, chain and hook, hex nut and blow moulded storage case.



**9
PIECES**

Model Number	Weight each	Order Code KEN-503	Price/1 TB
DP9	9.00kg	-3460K	4247.00

Panel Beating Dollies

Manufactured from drop forged medium carbon steel (SAE/AISI 1055). Heat-treated with a polished mirror finish.



Grid Dolly

For shrinking work. With a large crowned grid face on the surface and a plain flat face on the base this dolly, combined with a shrinking hammer and the use of heat, provides quick and effective shrinking.



Length (mm)	Order Code KEN-503	Price/1 TB
120	-7500K	876.00

Double-End Hand Dolly

For reshaping crowned panels and general panel beating.



Length (mm)	Order Code KEN-503	Price/1 TB
758	-7520K	1007.00

Utility Dolly

Double-sided multi-purpose. Use the edge most suited to the size and shape of a damaged flange.

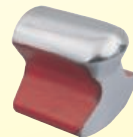

Length (mm)	Order Code KEN-503	Price/1 TB
64	-7540K	979.00

Toe Dolly (Low Crown Dolly)

For reshaping. Can be used in the hand to deliver a series of blows to the underside of the panel. Long crown enables use in hard to reach areas.



Length (mm)	Order Code KEN-503	Price/1 TB
120	-7560K	1176.00

Curved Dolly

For raising low spots on panels. The edge can also be used to restore the shape of a roof and reform beads.



Length (mm)	Order Code KEN-503	Price/1 TB
132	-7580K	1258.00

Heel Dolly

For general reshaping of contoured panels, raising low spots and general panel beating.



Length (mm)	Order Code KEN-503	Price/1 TB
81	-7600K	1012.00

Spot Weld Remover

Suitable for cutting holes in steel metal, steel, plastic and brass. The hardened steel cutter is reversible increasing tool life. Adjusting the spring loaded centre point screw accurately controls the depth of cut allowing the top to be removed whilst leaving the lower panel in place.



Capacity (mm)	Shank (mm)	Maximum Rated Operating Speed	Weight each	Order Code KEN-503	Price/1 TB
10	6.5	900rpm	30g	-1200K	742.00

3 Piece Panel Seam Splitter Set

Ideal for separating spot-welded panels during repairs. Stainless steel coated chrome vanadium with through tang shafts allow use with hammers. Dual material soft grip handles for comfort and control. Includes 90°, curved and straight seam splitters. Cushioned handle absorbs any shock from hammer blows. Made from super tough alloy steel.



**3
PIECES**

Number of Pieces	Weight each	Order Code KEN-503	Price/1 TB
3	94g	-7710K	1803.00

Trim Pin Remover

Designed for removing vehicle trim panels and upholstery. Also used for replacing door locks, window mechanisms and general bodywork repairs.



Overall Length	Weight each	Order Code KEN-503	Price/1 TB
230mm	155g	-1500K	387.00

KENNEDY **Lever Operated Vacuums**
QUALITY INDUSTRIAL TOOLING

For use in hand lift applications only. Multiple vacuums used on a single load can only improve handling. If using more than one vacuum tool the ratio of maximum lift capacity does not increase. To lift heavier weights a larger vacuum must be used. All are fitted with a rubber suction cap which will not damage contact surface during the lifting action. For use on glass and plastic or any smooth surface material and can also be used for pulling out dents.

- Single (VLS045)
- Double (VLD070)
- Triple (VLT070)



Model Number	Cups	Max Lift	Order Code KEN-503	Price/1 TB
VLS045	1x10cm	45kg	-2620K	563.00
VLD070	2x12cm	70kg	-2640K	1722.00
VLT070	3x12cm	110kg	-2660K	2487.00

Filler Applicators

100mm wide plastic spreader, suitable for the application of auto body filler.



PACK OF 5

Pack Quantity	Size	Order Code KEN-503	Price/1 TB
5	100mm (4")	-2820K	274.00

Auto Body Filler Applicator Set

4 Piece Set
Spring steel blades with composite grips. Suitable for the application of auto body filler.

Blade widths:
12, 25, 50 and 75mm.
Size (W x H x D):
123 x 210 x 5mm.



4 PIECES

Description	Order Code KEN-503	Price/Pk TB
Auto Body Filler Applicators	-2825K	384.00

Universal Door Handle Clip Remover

Removes door panel clips without breakage. Simple action - insert the tool and push the clip out.



Size (mm) (W x H x D)	Weight each	Order Code KEN-503	Price/1 TB
84 x 254 x 30	45g	-2790K	155.00

Folding Windscreen Stand

Lightweight tubular steel design with chain stops, foam protection and rubber feet. Large rubber suckers prevent screen from moving during preparation.



Folding frame makes this ideal for both workshop and mobile screen preparation. **Supplied flat pack for self-assembly.**

Type	Weight each	Order Code KEN-503	Price/1 TB
Windscreen Stand	7.6kg	-2890K	6309.00

Windscreen Moulding Release Tool

Removes trim moulding around cemented windscreen and rear windows quickly and easily.



Type	Weight each	Order Code KEN-503	Price/1 TB
Windscreen Release Tool	90g	-2810K	155.00

Wax Injector Gun

WIG100
Pneumatic tool for spraying and injecting wax underseal into areas that are difficult to access, such as door cavities, inside box section chassis and around wheel arches. Has a 1ltr container with a 1/4" NPT connection, operates from 90 - 145psi (6 - 10bar) air pressure with an air consumption rate of 380ltr/min and a vacuum of (maximum) 550mm HG. Supplied with 900mm spray hose and hanging hook.



1 LTR

Size	Order Code KEN-503	Price/1 TB
1ltr	-1880K	2653.00

Universal Trim Pad Remover

For removing plastic interior trim retaining studs. Corrosion-resistant.



Size (mm) (W x H x D)	Weight each	Order Code KEN-503	Price/1 TB
84 x 259 x 30	135g	-2800K	258.00

Glass Run Channel Cleaner

Automotive glass run channel cleaners are for the fast removal of glass, chips and debris from run channels on side windows. Suitable for unhooking locking weather strips around windscreens, with a long shaft for reaching deep into door recess. Manufactured from hardened and tempered chrome vanadium steel with a comfort grip.



-8730K



Overall Length	Weight each	Order Code KEN-503	Price/1 TB
260mm	150g	-8710K	205.00
330mm	190g	-8720K	232.00
610mm	190g	-8730K	361.00

Automotive Curved Hook Tools

Curved hook tools are for inserting and removing rubber seals and gaskets, they feature a long shaft and curved head for smooth operation in both directions. Manufactured from hardened and tempered chrome vanadium steel with a comfort grip.



Overall Length	Weight each	Order Code KEN-503	Price/1 TB
230mm	120g	-8760K	493.00
295mm	150g	-8770K	603.00

Windscreen Wiper Arm Removal Tool

Windscreen wiper arm removal tool for removing stuck and stubborn taper fitting wiper arms.

Maximum opening: 27mm.
Collar size: 15mm.



Description	Order Code KEN-503	Price/1 TB
Windscreen Wiper Arm Removal Tool	-1570K	411.00

HAND TOOLS

KENNEDY Hydraulic Body Repair Kits
QUALITY INDUSTRIAL TOOLING

Porta Power with Ram & Spreader

Used for clamping, pulling, bending, straightening, spreading and lifting operations. Snaps together. Heavy-duty hand pump has automatic overload feature. Tough, blow moulded case. Strong flexible hose with spring guards at both ends. 10,000PSI hydraulic hand pump, 1/2 Tonne ram and spreader.



Body Repair Kit Spares

Description	4 Tonne		10 Tonne			
	Size	Order Code KEN-567	Price/1 TB	Size	Order Code KEN-567	Price/1 TB
Spreader Ram	-	-8240K	2421.00	-	-8240K	2421.00
Spreader Ram Repair Kit	-	-8250K	160.00	-	-8250K	160.00
Small Extension Tube	100mm	-8280K	308.00	125mm	-8420K	773.00
Medium Extension Tube	200mm	-8290K	464.00	250mm	-8430K	799.00
Long Extension Tube	305mm	-8300K	567.00	355mm	-8440K	979.00
Extra Long Extension Tube	410mm	-8310K	593.00	480mm	-8450K	1288.00
Double Ended Male Snap Connector	-	-8320K	186.00	-	-8460K	464.00
Flat Base	114x63mm	-8330K	314.00	150x95mm	-8470K	1029.00
90° V' Base	-	-8340K	239.00	-	-8480K	387.00
Wedge Head	-	-8350K	208.00	-	-8490K	464.00
Spread Plunger Toe	-	-8360K	266.00	-	-8500K	773.00
Spreader Ram Toe	-	-8370K	372.00	-	-8510K	670.00
Rubber Head	67mm ø	-8380K	372.00	75mm ø	-8520K	567.00
Serrated Saddle	35mm ø	-8390K	208.00	46mm ø	-8530K	335.00
Seal Repair Kit	-	-8000K	266.00	-	-8020K	585.00
Replacement Blow Mould Case	-	-8400K	1597.00	-	-8540K	4119.00

Kit Size	Stroke Length	Order Code KEN-503	Price/1 TB
4 Tonne	100mm	-7240K	13389.00
10 Tonne	150mm	-7260K	20543.00

Single Speed Hydraulic Hand Pumps

Rugged construction with an internal overload valve, a pressure rating of 10,000psi (700bar) and a 1/4 NPT thread size. Operates in a vertical and horizontal position.



Model Number	Pressure Rating PSI (Bar)	Usable Oil Capacity	Oil Volume Per Stroke	Oil Port Thread	Length (mm)
HPS035	10,000 (700)	350cc	3.2cc	1/4 NPT	292
HPS060	10,000 (700)	600cc	3.2cc	1/4 NPT	478

Model Number	Weight each	Order Code KEN-503	Price/1 TB
HPS035	5.70kg	-8800K	6285.00
HPS060	7.10kg	-8820K	8851.00

Spares

Description	Order Code KEN-567	Price/1 TB
Connection Hose (1500mm x 1/4" NPT)	-8120K	1858.00
Repair kit for HPS035	-8050K	478.00
Repair kit for HPS060	-8060K	478.00

Hydraulic Push Rams

Rugged construction with a heavy-duty return spring. Chrome plated piston inhibits rusting. 1/4 NPT thread size. Accessories easily snap on.



Model Number	Capacity (Tonne)	Stroke (mm)	Oil Cap (cc)	Cylinder Bore dia.	Length Ret.	Length Ext.	Outside dia. Piston Ram	Oil Port Thread
HRP004	4	100	65	28.5mm	230	330	22 38	1/4 NPT
HRP010	10	150	243	45.0mm	325	475	33 57	1/4 NPT

Model Number	Weight each	Order Code KEN-503	Price/1 TB
HRP004	1.80kg	-7170K	3716.00
HRP010	5.30kg	-7190K	10109.00

Twin Speed Hydraulic Hand Pumps

Rugged construction. Internal overload valve prevents it from being used beyond rated capacity. Operates in a vertical and horizontal position. Pressure rating 10,000psi (700bar). 3/8 NPT thread size. Pump handle locks into place to be used as a carrying handle.



Model Number	Pressure Rating PSI (Bar)		Usable Oil Capacity	Oil Volume Per Stroke		Oil Port Thread	Length (mm)
	Stage 1	Stage 2		Stage 1	Stage 2		
HPT035	200 (13.8)	10,000 (700)	350cc	7.0cc	1.0cc	3/8 NPT	310
HPT070	200 (13.8)	10,000 (700)	600cc	13.0cc	2.8cc	3/8 NPT	528
HPT250	200 (13.8)	10,000 (700)	2500cc	13.0cc	2.8cc	3/8 NPT	632

Model Number	Weight each	Order Code KEN-503	Price/1 TB
HPT035	5.30kg	-8900K	8692.00
HPT070	8.00kg	-8940K	9697.00
HPT250	12.0kg	-8960K	12868.00

Spares

Description	Order Code KEN-567	Price/1 TB
Connection Hose (1500mm x 3/8" x 1/4" NPT)	-8140K	1858.00
Repair kit for HPT035	-8080K	691.00
Repair kit for HPT070	-8090K	903.00
Repair kit for HPT250	-8100K	955.00

Hydraulic Pull Back Ram

Rugged construction with a heavy-duty return spring. Chrome plated piston inhibits rusting. 1/4 NPT thread size. Accessories easily snap on. For use with Porta Power/Body Dozer power units.



Model Number	Capacity (Tonne)	A Stroke (cm)	Cylinder Bore Diameter (mm)	B Overall Length (mm)	Oil Port Thread
HRP005	5	15	34	740	1/4 NPT

Model Number	Weight each	Order Code KEN-503	Price/1 TB
HRP005	6.70kg	-7180K	9126.00

KENNEDY Hydraulic Bench Presses
QUALITY INDUSTRIAL TOOLING

Ideal for pressing, bending and extruding. The Hydraulic pump can be manually operated or by compressed air connecting the airline supplied to an air supply line or direct to a compressor providing at least 8 - 9.5bar at 4cfm. Hydraulic gauge is included. Ideal for industrial and automotive applications.

20 Tonnes

Sturdy steel frame with end braces and wide feet for extra stability. Work bed height is adjustable in 8 increments of 120mm, allowing large work pieces to be worked on with maximum flexibility.

Capacity: 20 tonnes.

30 Tonnes

Heavy duty steel frame with end braces and wide feet for maximum stability. Work bed height is fully adjustable in 7 increments of 140mm, giving increased flexibility when working with large work pieces.

Capacity: 30 tonnes.

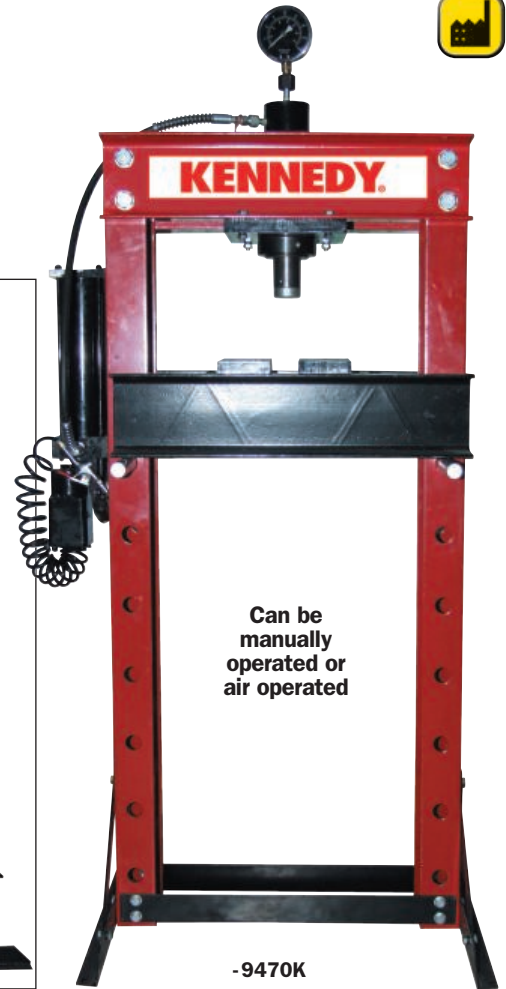
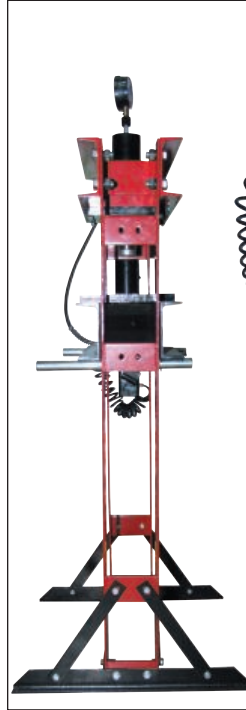

Capacity	Work Bed Adjustable Height	Order Code	Price/1 TB
20 Tonne	8 Increments of 120mm	-9460K	40978.00
30 Tonne	7 Increments of 140mm	-9470K	62833.00

Seal Repair Kits

Description	Order Code	Price/1 TB
For 20T Ram	-8550K	1804.00
For 20T Pump	-8560K	1804.00
For 30T Ram	-8570K	1804.00
For 30T Pump	-8580K	1804.00

Hydraulic Bench Press

Ideal for pressing, bending and extruding. Built for tough daily use in industrial and automotive workshops, manufactured welded steel frame with two end braces for stability and a fully adjustable work bed providing flexibility and convenience. Fitted with a detachable pump and ram allowing hydraulics to be used for other purposes when the press is not being used. Hydraulic gauge is included.

Capacity: 10 tonnes.

These hydraulic presses are ideal for assembly, straightening, fabrication, quality control, maintenance, product testing, bending, forming, punching and shearing.

- Model number** HBPO10.
- Capacity** 10 Tonne.
- Ram stroke** 150mm.
- Extension screw** 60mm.
- Max height of ram to table** 300mm.
- Min height of ram to table** 90mm.
- Table aperture** 140mm.
- Working table width** 360mm.
- Overall height** 895mm.
- Hydraulic gauge included** Yes.
- Weight** 47kg.

1 tonne (metric ton or t) = 1000kg
 1 ton (imperial ton) = 2240lbs (1016kg)

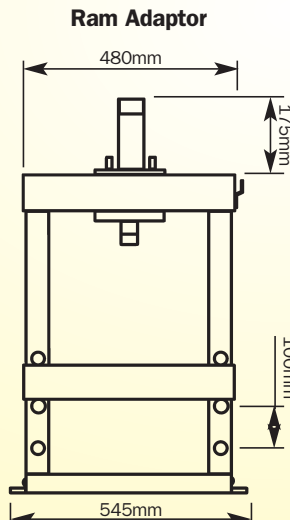
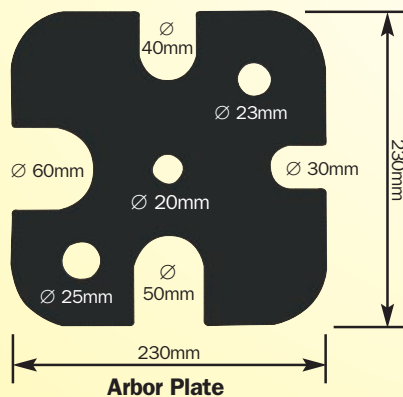

Ram Adaptor

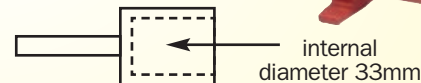
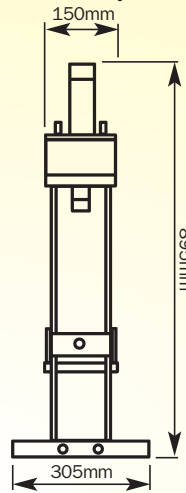

Spare pump available - (KEN503-8820K), see page 328.

Model Number	Capacity	Overall Height (mm)	Weight each	Order Code	Price/1 TB
HBPO10	10 Tonne	895	47kg	-5000K	28325.00
Accessories		Description	Weight each	Order Code	Price/1 TB
Seal Repair Kit			10g	-8220K	670.00
Pressure Gauge				-5570K	2059.00
		Description		Order Code	Price/1 TB
		Hydraulic Ram		-1530K	5923.00
		Arbor Plate		-7290K	3605.00

PRODUCTS ARE ONLY AVAILABLE VIA YOUR DISTRIBUTOR



Brake Pedal Depressor

Ingenious tool for depressing and holding down the brake pedal whilst carrying out maintenance.

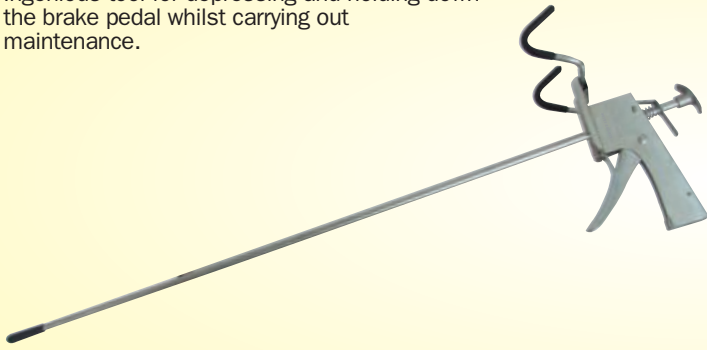

Description	Order Code KEN-503	Price/1 TB
Brake Pedal Depressor	-1910K	2059.00

Hose Pinch Clamp Set

HPS003

These professional tools are for clamping flexible hoses from 11mm to 60mm in diameter. Made from a composite of glass reinforced nylon, they are lightweight, tough and have smooth rounded jaws to prevent damage to internal reinforcement.

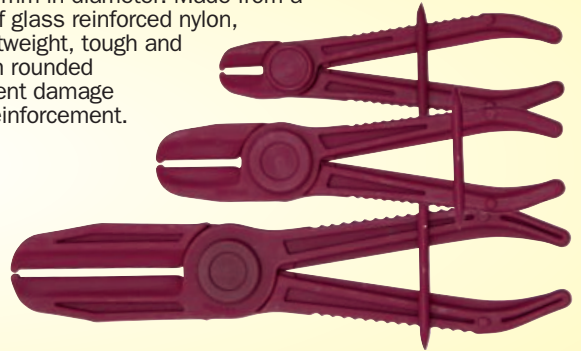

**3
PIECES**

Hose Range	Weight each	Order Code KEN-503	Price/1 TB
11-60mm	330g	-1940K	1530.00

Brake Pin Punches

Parallel pin punches for the removal of brake caliper pad retaining pins. 6.0mm diameter punch uses a pilot tip to aid location in hollow pins used on GM/Vauxhall calipers.

Overall length: 165mm.



Diameter (mm)	Weight each	Order Code KEN-503	Price/1 TB
5.5	95g	-4910K	308.00

Brake Spring Cup Washer Tool

Removes and replaces T-slot anti-rattle spring washers found in drum brake assemblies. Hardened and tempered carbon steel shank and cup with oxidised finish for protection against corrosion, bevelled and notched cup fits 16 - 22mm (5/8" - 7/8") diameter. Impact resistant square section handle for secure grip even when greasy.

Overall length: 152mm (6").



Product Number	Weight each	Order Code KEN-503	Price/1 TB
BST122	110g	-4940K	170.00

Brake Clip Tool

Designed for import cars with brake shoe hold down clips. Removes and installs brake clip and nail on brake shoes in seconds. Impact resistant square section handle for secure grip even when greasy.

Overall length: 200mm (8").



Product Number	Weight each	Order Code KEN-503	Price/1 TB
BSC150	165g	-4960K	411.00

Brake Fluid Tester (Battery Operated)

This ingenious tool is invaluable in the garage workshop for testing the quality of brake fluid. Testing for moisture content in the fluid by resistance to electric current. You get instant results from the built-in LED indicator light system. (Runs on 1x 1.5V AAA battery).



Description	Order Code KEN-503	Price/1 TB
Brake Fluid Tester	-1130K	1288.00

Extra Heavy Duty Ear Type Clip Pliers

These pliers have steel jaws, PVC coated handles and a 1/2" sq for use with torque wrenches and bar breakers. Suitable for all ear type CVJ boot clips.



Product Number	Order Code KEN-503	Price/1 TB
AT4185	-4820K	1288.00

Brake Caliper Spreader

Retracting brake caliper pistons can be used with 1/2" square drive ratchet and 21mm hex wrench or spanner and is suitable for use on most cars and motorcycles. Constructed from hardened steel with phosphate finished spreader plates for corrosion protection.



Product Number	Weight each	Order Code KEN-503	Price/1 TB
BCS065	830g	-1900K	1643.00

Brake Pad Key

8mm hexagon key. 140mm handle for optimum leverage and grip. Suitable for disc brake caliper retaining bolts on many modern cars. Manufactured from chrome vanadium steel with corrosion resistant phosphated finish.



Size	Weight each	Order Code KEN-503	Price/1 TB
8mm Hex	245g	-2880K	205.00

Spring Type Hose Pinch Tool

For clamping flexible brake lines, fuel lines, vacuum hose and other fluid lines up to 12mm diameter. Allows servicing to be carried out without the need for system draining. Sliding lock collar allows hoses to be fully or partly closed. Smooth rounded jaw edges avoid damage to hoses. All steel construction with corrosion-resistant chrome finish.

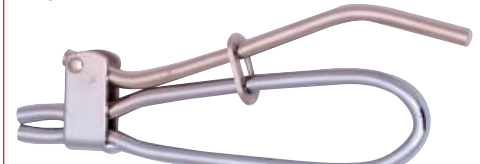

Maximum Diameter	Weight each	Order Code KEN-503	Price/1 TB
12mm	160g	-2840K	466.00

Ratcheting Hose Pinch Pliers

For clamping flexible brake lines, fuel lines, vacuum hose and other fluid lines. Heavy duty serrated jaw edges provide excellent clamping whilst avoiding damage to hoses. Jaws pivot and self-level to ensure parallel clamping. Fine-adjusting ratchet action allows hoses to be fully or partly closed. All steel construction with corrosion-resistant finish.



Overall Length	Weight each	Order Code KEN-503	Price/1 TB
200mm	295g	-2850K	720.00
250mm	435g	-2860K	747.00
300mm	565g	-2870K	773.00

HAND TOOLS



AUTOMOTIVE - BRAKING SYSTEM TOOLS



Pneumatic Brake & Clutch Bleeder

PBB100

Has a 1ltr container with a 1/4" NPT connection, operates from 90 - 145psi (6 - 10bar) air pressure with an air consumption rate of 180ltr/min, an extraction rate of 1.6ltr/min and vacuum (max) of 550mm HG.

Handles non-flammable liquids between 0 and 80°C.



Product Number	Capacity (litre)	Weight each	Order Code KEN-503	Price/1 TB
PBB100	1.0	470g	-1920K	2294.00

Remote Hose Clamp Pliers

For the removal and replacement of fuel, oil and water hoses. Flexible 530mm long reach ratchet mechanism allows the pliers to release and lock hose clamps in the opened position. Supplied with cable clamping nipple for use when replacing the cable.



Capacity	Weight each	Order Code KEN-503	Price/1 TB
55mm	575g	-1970K	2936.00

Angled Flat Band Hose Clamp Pliers

Removes and installs flat band hose clamps. Swivel tips to grip at any angle. Locking handle allows user to maintain 'open' position and hold clamp in place.



Overall Length	Weight each	Order Code KEN-503	Price/1 TB
215mm	200g	-1960K	670.00

Heavy Duty Hose Clip Pliers - Clic Compatible

With steel jaws and PVC coated handles. These spring loaded dual purpose pliers are designed for fitting and removing Clic and Clic-R® hose clips.



Overall Length	Weight each	Order Code KEN-503	Price/1 TB
260mm	230g	-4810K	1029.00

Vacuum Testing & Brake Bleeding Kit

Vacuum testing kit that helps to locate and identify faults on cars, motorcycles and commercial vehicles. Supplied in robust blow moulded case.

Contents: serviceable metal bodied vacuum pump, reservoir jar, transfer lid, storage lid, 4x lengths of 6mm ID tubing, 1x length of 4mm ID tubing adaptor. Set of brake bleeding adaptors, rubber cup adaptor.

Maximum vacuum: 550mm Hg.
Reservoir capacity: 150ml.



Description	Order Code KEN-503	Price/1 TB
Vacuum Testing & Brake Bleeding Kit	-2720K	3930.00

Pressure Tester

Cooling System & Radiator Cap Pressure Tester

Designed for the pressure testing of cooling systems and radiator caps up to 35psi (2.5bar). Suitable for use on most makes of car and commercial vehicles, including: Mercedes, Ford, Chrysler, Peugeot, Honda, Lexus, Mazda, Suzuki, Toyota, Nissan, Opel, Volkswagen, Saab, Volvo, Audi, Citroen, Fiat and BMW.

Contents: 14 radiator pressure testing caps, for use in testing cooling systems for leaks. Two cap adaptors, sizes 2 - 3 and 4 - 5, for testing radiator cap release pressure and seal condition. Two 200psi coolant hoses (5/16" and 3/8"), for use with T-adaptor for in-line pressure testing. T-adaptor for creating in-line pressure testing set-up. Two 3/4" hose clips.

Description	Order Code KEN-503	Price/1 TB
Cooling System & Radiator Pressure Tester	-0960K	25622.00



BEST SELLER

Universal Caliper Wind-Back Tool Kits

Winds back disc brake calipers when replacing brake pads. Professional quality, allows the easy return of brake piston into the caliper. Suitable for most braking systems.



Number of Pieces	Order Code KEN-503	Price/1 TB
12	-2770K	3193.00
18	-1890K	3089.00



Compression Tester

Suitable for all types of spark plugs. Finds faults in piston rings, valves, head gaskets and cylinder bores. Suitable for use on most petrol engine vehicles and motorcycles. Can be used on crankshaft seals in two stroke engines. 195mm flexible hose. For use on 14mm and 18mm threads.

Large easy to read scale 0 - 21bar/ 0 - 300psi. Air release valve to allow rapid re-testing.



BEST SELLER

Description	Weight each	Order Code KEN-503	Price/1 TB
Petrol engine Compression Tester	440g	-1160K	1963.00

Vacuum & Fuel Pump Tester

Suitable for use on most engines. Large, easy to read dual calibrated colour coded scale. Suitable for all types of spark plugs. Can be used on crankshaft seals in two-stroke engines. Suitable for testing and finding fault in petrol engines with spark misfires, poor engine compression, weak/rich mixture, ignition over advanced/retarded, inlet manifold and carburettor air leaks, incorrect valve timing and poor fuel economy. Can be used for carburettor balancing, checking turbo boost pressure up to 0.7bar and fuel pump.



Description	Weight each	Order Code KEN-503	Price/1 TB
Vacuum Tester	440g	-1140K	933.00

HAND TOOLS



Valve Spring Compressor

Fully adjustable valve spring compressor for use on large and diesel engines. A unique 'direct action' compressor lever gives improved visibility and ease of use in areas of difficult access. Manufactured from heavy duty steel with all rivetted joints and a slip resistant rubber handle.

Restricted access adaptors: 25, 30mm.
Jaw opening: min. 35mm, max. 200mm.
Throat clearance: 250mm.



35 - 200mm Capacity

Capacity Min./Max.	Weight each	Order Code KEN-503	Price/1 TB
35 - 200mm	2.50kg	-2700K	2833.00

Valve & Piston Ring Compressors

Designed for use on production lines as well as in the automotive workshop. Able to cope with occasional commercial use. Manufactured from bright nickel plated steel with PVC cushion grips.

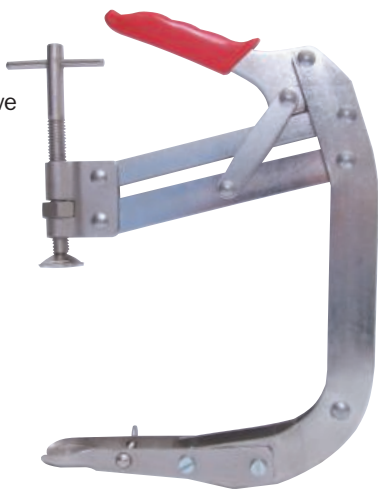

Opening Capacity	Weight each	Order Code KEN-503	Price/1 TB
75 - 230mm	1.30kg	-2010K	1803.00

Piston Ring Compressors

The compressor gently compresses the piston rings into position reducing the risk of damage to components during installation. Key operated with ratchet mechanism and safety valve for combining safe rapid compression with positive control. Made from tempered spring steel complete with steel key.

PRC-540 - Passenger car vehicle engines.

Capacity: 57 - 125mm (2¼" - 5").

Height: 80mm (3¼").

PRC-730 - Car/light commercial vehicle engines.

Capacity: 90 - 175mm (3½" - 7").

Height: 100mm (4").

PRC-765 - Heavy commercial vehicle engines.

Capacity: 90 - 175mm (3½" - 7").

Height: 165mm (6½").

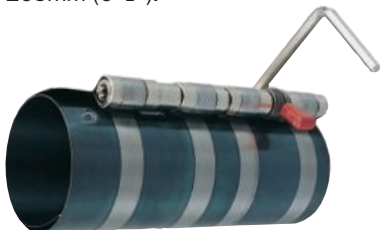

Model Number	Weight each	Order Code KEN-503	Price/1 TB
PRC540	260g	-2210K	794.00
PRC730	300g	-2240K	979.00
PRC765	560g	-2270K	1744.00

Valve Spring Compressor



Fully adjustable valve spring compressor for use on multi-valve petrol and diesel engines with deep seated valves. Universal model with unique dual-cam action, parallel lift and automatic locking reversible jaw/adaptor, suitable for general use on a wide range of OHC, OHV and CVH engines. A unique 'direct action' compressor lever gives improved visibility and ease of use in areas of difficult access. Manufactured from heavy-duty steel with all rivetted joints and a slip resistant rubber handles.

Restricted access adaptors:

25, 30mm.

Jaw opening:

min. 55mm, max. 175mm.

Throat clearance: 165mm.

Packaging dimensions (W x H x D):

430 x 205 x 40mm.



55 - 175mm Capacity

Capacity Min./Max.	Weight each	Order Code KEN-503	Price/1 TB
55 - 175mm	2.20kg	-2710K	2936.00

Piston Ring Pliers

To enable fast installation or removal of piston rings. A self-adjusting spring tensioned mechanism manufactured from nickel-plated steel with PVC handles for extra grip.

Capacity: 50 - 100mm (2" - 4").



Capacity (mm)	Weight each	Order Code KEN-503	Price/1 TB
50 - 100	250g	-2090K	1056.00

Straight Head Valve Seal Ring Pliers

Standard Length

For the easy removal of most valve stem seals and lower valve spring guides in restricted areas above the cylinder head.

Overall length: 250mm, 50mm reach.



Extra Long

For the easy removal of most valve stem seals in multi-valve engines in restricted areas above the cylinder head. Gripping serrations inside the jaws aid gripping the outside diameter of the valve stem seal. Steel pliers with double rivetted metal handles.

Overall length: 270mm, 80mm reach.



Type	Order Code KEN-503	Price/1 TB
Standard	-2680K	712.00
Extra Long	-2690K	979.00

AUTOMOTIVE - CYLINDER, PISTON & VALVE TOOLS

KENNEDY *Cylinder Hone*
QUALITY INDUSTRIAL TOOLING

For honing of brake cylinders and piston bores with capacities between 19 - 68mm. Self aligning flexible shaft and leg assembly for smooth operation at all speeds. Honing diameter and pressure is adjusted via a simple, spring and cone mechanism. Suitable for use with a variable speed electric or air drill and fits into all 3 jaw chucks. Supplied complete with a medium grade stone set. For storage purposes legs are retained in position by a triangular clip. This can be removed using long nose pliers or tweezers and should be retained for further use. Replacement stone sets available.

Use brake fluid for cutting lubricant.

Overall length: 200mm.



Heavy Duty Cylinder Hone

For honing of brake cylinders and piston bores with capacities between 51 - 178mm. Self-aligning flexible shaft and leg assembly for smooth operation at all speeds. Honing diameter and pressure is adjusted via a simple, spring and cone mechanism. Suitable for use with a variable speed electric or air drill and fits into all three jaw chucks. Supplied complete with a fine grade stone set. For storage purposes legs are retained in position by a triangular clip. This can be removed using long nose pliers or tweezers and should be retained for further use. Replacement stone sets available.

Use brake fluid for cutting lubricant.

Overall length: 290mm.



Type	Weight each	Order Code KEN-503	Price/1 TB
3 Leg	380g	-2920K	2035.00
Replacement Stones - 100 x 9mm - 3 Piece			
Fine	88g	-2950K	871.00
Medium	93g	-2960K	881.00
Coarse	97g	-2970K	881.00

Type	Weight each	Order Code KEN-503	Price/1 TB
3 Leg	105g	-2940K	773.00
Replacement Stones - 29 x 4.5mm			
Medium	83g	-2980K	384.00

Cylinder Hone Set

Four different honing tools in one set suitable for honing/deglazing car brake and clutch cylinders, motorcycle, lawnmower, outboard motor engine cylinders, small bore car engine cylinders with capacities between 18 - 89mm. Self-aligning flexible shaft and leg assembly for smooth operation at all speeds and easy alignment. Honing diameter and pressure is adjusted via a simple, spring and cone mechanism. Suitable for use with a variable speed electric or air drill and fits into all three jaw chucks. Supplied in a plastic blow-moulded case.

Overall length: 200mm.

Set Contents:

Main honing body, twin leg set - 50mm, triple leg set - 50mm, triple leg set - 60mm; three sets of medium stones: 19 x 4.5mm (x3 off), 29 x 4.5mm (x5 off) and 51 x 7.0mm (x3 off).

Twin Leg 18 - 64mm

For small brake cylinders. 50mm twin leg set and 2x 29mm stones. (NB Ready assembled in kit)

Triple Leg 19 - 68mm

For large brake/clutch cylinders. Use medium collar, 50mm triple leg set and 3x 29mm stones.

Triple Leg 32 - 89mm

For disc brake cylinders. Use large spring, 60mm triple leg set and 3x 19mm stones.

Triple Leg 32 - 89mm

For small engine cylinders. Use large spring, 60mm triple leg set and 3x 51mm stones.



Type	Weight each	Order Code KEN-503	Price/1 TB
4-in-1	248g	-2930K	1288.00

Replacement Stone Sets Medium- 3 Piece

L x W (mm)	Weight each	Order Code KEN-503	Price/1 TB
19 x 4.5	83g	-2990K	301.00
29 x 4.5	89g	-2980K	384.00
51 x 7.0	99g	-3000K	357.00

HAND TOOLS

GROUP 503 AUTOMOTIVE - INSPECTION

KENNEDY PROFESSIONAL

2-in-1 Padded Creeper Board & Seat

Heavy duty steel frame with powder coat finish. Vinyl coated cushioning. Quickly converts from creeper to seat. Adjustable back and parts tray when in the seat position.



Size L x W x H (mm)	Weight each	Order Code KEN-503	Price/1 TB
1050 x 480 x 100	13.0kg	-7300K	4698.00

Padded Creeper Board

Both the creeper board and seat framework are manufactured from heavy steel with a powder paint finish. Furnished with a vinyl covered cushioning and are fitted with castor wheels for ease of movement.



Padded Creeper Seat

The creeper seat is fitted with a parts tray for tools and components.

Type	Size L x W x H (mm)	Weight each	Order Code KEN-503	Price/1 TB
Board	1050 x 480 x 100	7.00kg	-7320K	2596.00
Seat	365 x 355 x 355	3.50kg	-7340K	1526.00

Creeper Board with Magnetic Trays

KMC01
High-impact moulded plastic creeper board lets you work under vehicles with ease. Low profile design to provide greater clearance. Padded headrest with removable magnetic tool trays and 6x 75mm PVC coated castor wheels.

Capacity: 113kg (250lbs).
Dimensions (L x W x H): 1020 x 475 x 120mm.
Weight: 5kg.



Type	Size L x W x H (mm)	Weight each	Order Code KEN-503	Price/1 TB
Board	1020 x 475 x 120	5.00kg	-7420K	3225.00

SENATOR QUALITY TOOLING Lightweight Plastic Creeper Board

Durable, lightweight moulded plastic creeper board ideal for use in garages. Padded headrest with 4x 50mm polypropylene castor wheels.

Capacity: 127kg (280lbs).
Dimensions (L x W x H): 910 x 405 x 105mm.
Weight: 3kg.



Type	Size L x W x H (mm)	Weight each	Order Code SEN-503	Price/1 TB
Board	910 x 405 x 105	3.00kg	-7378K	1640.00

HAND TOOLS

KENNEDY **30+ 7 LED Rechargeable Worklight - 230V**
QUALITY INDUSTRIAL TOOLING

37 super bright LEDs. Dual use as an inspection lamp or directional torch. Moisture protection IP44. Two magnets and two 360° swivel hanging hooks for hands free applications. Lower quarter of lamp rotates 180° to use as a stand. Supplied with AC/DC mains charger and 12V DC in-car charger for portable charging. 7.2V (800mAh) Lithium-Ion battery. Main light lasts up to four hours, and directional light lasts up to 20hrs, when fully charged.



Voltage	Weight each	Order Code	Price/1 TB
230V	260g	KEN-503	2733.00

24 LED Worklight

LWL024

24 super bright LEDs. Magnetic base. Soft touch durable composite casing. 360° swivel hanging hook for hands free applications. 3x AA batteries not supplied. Lasts for 4 - 5 hours approx. IP20 moisture protection.

Length: 208mm.



Type	Weight each	Order Code	Price/1 TB
3x AA Batteries	260g	KEN-503	384.00

LED Inspection Lamps

Durable and robust construction with a rubber handle and end cup, plus a sturdy swivel hanging hook making it ideal for use in engine bays and other low light work areas. Anti-roll hexagonal shape with a convenient grip mounted ON/OFF switch. Main light and spot light option.

Rechargeable

Main light lasts up to 3.5hrs when fully charged using the charger supplied.



Type	Order Code	Price/1 TB
Rechargeable	KEN-503	-5080K

EDISON **Rechargeable Lamp**

Ideal for use in automotive workshops and the construction industry. Heavy-duty rubber and polycarbonate case. Lasts up to 6hrs when fully charged. Adjustable brightness. Durable, robust and reliable. Foldaway swivel hanging hook, wall or bench mount charging base with 1.9m power cable*. 30 LEDs provide a constant high light output. Water and oil-resistant to IP68. Powered by high capacity Lithium-Ion polymer batteries. Optional flashing mode. Sealed switch. Can be stood upright. Uses induction charging technology. Battery low warning. *Screws and wall plugs for mounting the charging unit to a wall are not included.



Rated to IP68

Type	Order Code	Price/1 TB
Rechargeable Lamp	EDI-904	-1100K

Mechanic's Stethoscope

Professional stethoscope provides a fast and easy way to locate noises in engines or bearings and other moving parts. High quality surgical grade PVC and rubber parts for increased sound definition, plastic ear-pieces minimise outside noise with an aluminium alloy probe/needle for finding the exact location of specific noises. Supplied with rubber trumpet for checking vacuum and pressure flow. Useful for synchronising multi carburettors, helps to track dashboard rattles and is ideal for pinpointing unusual vibrations or suspected leaks, it is also shockproof.

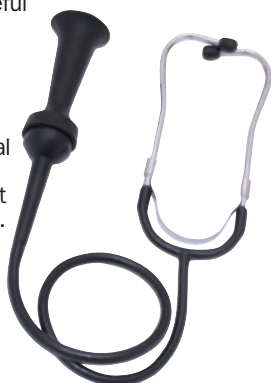

Product Number	Order Code	Price/1 TB
MSC110	KEN-503	-2740K

Lead Lamp Wire Cage

Designed for the professional, with heavy duty rubberised handle, wire protection cage with integral hook and 4.8m of cable. Accepts screw-in (ES) type bulb (supplied separately).



4.8m CABLE

Voltage	Weight each	Order Code	Price/1 TB
240V	995g	KEN-503	-5380K

SENATOR **QUALITY TOOLING**

Lead Lamp Plastic Cage

Plastic protection cage with integral hook and 4.8m of cable. Accepts screw-in (ES) type bulb (supplied separately).



4.8m CABLE

Voltage	Weight each	Order Code	Price/1 TB
240V	720g	SEN-503	-5370K

KENNEDY Bottle Jacks
QUALITY INDUSTRIAL TOOLING

With large cast iron bases with a steel cylinder housing and an adjusting notched saddle. Fitted with an overload protection valve. Two piece 'pumping' handle also operates hydraulic release. Use on a firm level surface. **DO NOT** work under the vehicle until another means of support, such as axle stands, are used. Models B234, B337 and B541 are supplied in a robust blow moulded carry case. **Complies with the EC Machinery Directive. GS and TUV approved.** (Load ratings are 'metric tonnes' i.e. 1 tonne = 1,000kg). All supplied with spare seals.



2, 3 and 5 tonne jacks supplied in a robust plastic case

Model Number	Max Load (Tonne)	Height (mm) Min. - Max.	Max Saddle Adjustment	Weight each	Order Code KEN-503	Price/1 TB
B234	2	181 - 345	48mm	3.00kg	-5820K	1219.00
B337	3	194 - 372	60mm	3.75kg	-5840K	1421.00
B541	5	216 - 416	70mm	4.90kg	-5860K	1417.00
B845	8	230 - 457	80mm	5.75kg	-5690K	1668.00
B1246	12	230 - 465	80mm	7.50kg	-5710K	2460.00
B1546	15	230 - 460	80mm	8.50kg	-5730K	2569.00
B2045	20	242 - 452	60mm	11.0kg	-5750K	2788.00

2.5 Tonne Low Profile Quick Lift Lightweight Trolley Jack

3 tonne capacity. Made of a lightweight aluminium and steel construction. Its low profile makes it ideal for any type of car, including sports and race cars, and its swivel castor wheels enable easier positioning under vehicles. It also has a quick lift with dual pump and a rubber hand grip for user comfort.

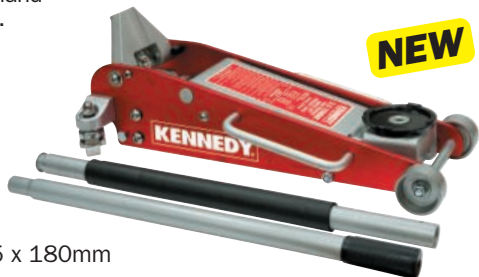

QUICK LIFT

Dimensions
QLT450: 685 x 345 x 180mm

Model Number	Maximum Load	Height (mm) Min. - Max.	Weight each	Order Code KEN-503	Price/1 TB
QLT450	2500kg	100 - 460	28.5kg	-6540K	14935.00

2 Tonne Low Profile Long Reach Trolley Jack

Low profile long reach trolley jacks have strong, robust steel chassis to provide stability when under load. A low entry height. Heavy duty fixed direction castors, swivel castors and inside wheel ensure excellent manoeuvrability and easy positioning under the vehicle prior to lifting. The foot pedal is to rapidly raise and lower the load arm and the vehicle. The long reach pump handle has a comfort rubber grip. Includes a practical tray for carrying tools and a rubber pad for the saddle. For use on a firm level surfaces.



DO NOT work under the raised vehicle until another means of support, such as axle stands are in place.

Model Number	Maximum Load	Height (mm) Min. - Max.	Weight each	Order Code KEN-503	Price/1 TB
T510L	2000kg	76 - 510	42kg	-6570K	18031.00
T525L	3000kg	140 - 525	50kg	-6580K	23690.00

Heavy Duty Bottle Jacks

With machined/cast steel bases and cylinder housings. Fitted with an overload protection valve. Three piece 'pumping' handle also operates hydraulic release. Use on a firm level surface. **DO NOT** work under the vehicle until another means of support, such as axle stands, are used.



Model Number	Max Load (Tonne)	Height (mm) Min. - Max.	Weight each	Order Code KEN-503	Price/1 TB
B3047	30	285 - 475	23.0kg	-5770K	6695.00
B5048	50	300 - 480	34.0kg	-5790K	11475.00

Low Profile Service Trolley Jacks

Low Profile Trolley Jacks have strong, robust steel chassis to provide stability when under load. A low entry height. Heavy duty fixed direction castors and swivel castors ensure easy positioning under the vehicle prior to lifting. The pump handle with comfort rubber grip is to rapidly raise and lower the load arm and the vehicle. For use on firm level surfaces. **DO NOT** work under the raised vehicle until another means of support, such as axle stands are in place.



Model Number	Maximum Load	Height (mm) Min. - Max.	Weight each	Order Code KEN-503	Price/1 TB
T5359	2000kg	89 - 359	14.5kg	-6520K	4919.00
T450L	2500kg	85 - 450	34.0kg	-6530K	8755.00

Air Trolley Jack - 20/40T 2 Stage

For use when lifting heavy vehicles such as lorries etc. This industrial air jack has a robust steel chassis, 'T' bar handle with integral air control valve and two extensions for increased lifting height. It requires an air pressure of 116 - 174psi (8 - 12bar) and a supply rate of 105ltr/min (3.7cfm).



JTA2040
Air supply: 116 - 174psi (8 - 12bar).
Air consumption: 105ltr/min (3.7cfm).
Lifting capacity: 20T/40T.
Base height: 210mm.
Lifting height: 40T - 433mm, 20T - 520mm.
Air inlet size: 1/4NTP.

Model Number	Maximum Load	Height (mm) Min. - Max.	Weight each	Order Code KEN-503	Price/1 TB
JTA2040	40T	210 - 520	74kg	-7120K	56650.00

HAND TOOLS

KENNEDY **3 Tonne Quick Lift Trolley Jack**
QUALITY INDUSTRIAL TOOLING

3 tonne capacity. One stroke instant lift foot pedal, raises the saddle up to jack point to increase productivity. Constructed from heavy gauge steel. 1m, two-piece handle. 120mm diameter saddle. Automatic safety overload protection. Positive twist, lock and release mechanism. Heavy duty rear swivelling castor wheels.

Maximum load: 3000kg.
Minimum height: 145mm.
Maximum height: 490mm.



Capacity	Weight each	Order Code KEN-503	Price/1 TB
3 Tonne	39.5kg	-7100K	12622.00

Scissor Jack

Made from heavy-duty steel with a rubber saddle which provides a positive grip and prevents damage to jacking points. Designed to safely raise vehicles. Easy to use and compact for easy storage. 1 Tonne (1000kg) safe working load. Wide base plate for extra stability.

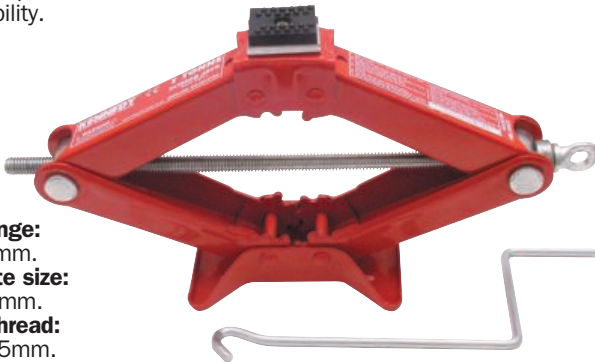

Lifting range: 88 - 383mm.
Base plate size: 150 x 90mm.
Spindle thread: 12.5 x 2.5mm.

Model Number	Capacity	Weight each	Order Code KEN-503	Price/1 TB
KSJ010	1 Tonne	2.80kg	-5920K	1176.00

Ratcheting Axle Stands

Suitable for supporting raised vehicles or equipment. Protective red enamel coating. 10-position ratchet design that automatically locks when raised.



Capacity/pair	Per Stand	Min. - Max. Height	Order Code KEN-503	Price/Pr TB
4 Tonne (4000kg)	2T	265-418mm	-5520K	1612.00
6 Tonne (6000kg)	3T	280-420mm	-5530K	2563.00
12 Tonne (12000kg)	6T	390-608mm	-5560K	4099.00

Trolley Jack

Strong steel chassis provides stability when under load. Fixed direction castors and swivel castors for easier positioning under vehicles. Long reach single piece pump handle with comfort rubber for rapid raising and lower. Safety overload protection valve prevents overload damage to hydraulic mechanism. Integral carry handle.

GS and TUV approved.
T238
Type: with case.
Dimensions: 525 x 225 x 145mm.
T2.249
Type: with case.
Dimensions: 695 x 344 x 180mm.
T280
Type: long reach.
Dimensions: 1150 x 360 x 210mm.

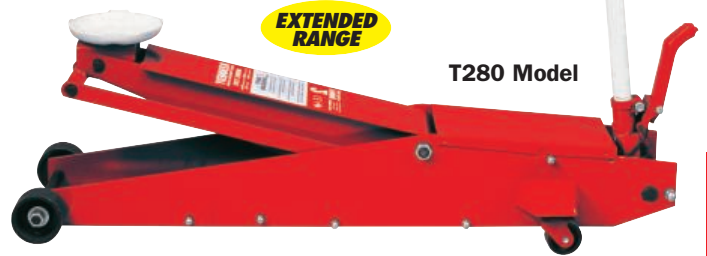

Model Number	Maximum Load	Height (mm) Min. - Max.	Weight each	Order Code KEN-503	Price/1 TB
T238	2000kg	130 - 380	12.0kg	-6320K	4099.00
T2.249	2250kg	145 - 495	36.5kg	-6350K	7983.00
T280	2000kg	140 - 800	58.0kg	-6920K	19123.00
HTJ03	3000kg	150 - 490	36.5kg	-6360K	9116.00

Spares

Description	Weight each	Order Code KEN-567	Price/1 TB
Torsion Spring for T280	49g	-7880K	160.00
Torsion Spring for T2.249	49g	-7860K	186.00
Seal Repair Kit for T238	7g	-8160K	160.00
Seal Repair Kit for T2.249	4g	-8180K	239.00

SENATOR **Hydraulic Trolley Jacks**
QUALITY TOOLING

Featuring steel chassis for stability, swivel castors for easier positioning and 1 piece handle with rubber grip for extra comfort. With overload protection valve, separate release mechanism and integral carry handle.



Model Number	Maximum Load	Height (mm) Min. - Max.	Weight each	Order Code SEN-503	Price/1 TB
STJ330	2000kg	135 - 330	8.50kg	-6320K	3300.00
STJ410	3000kg	130 - 410	15.84kg	-6360K	4250.00

Description	Weight each	Order Code SEN-567	Price/1 TB
Seal Repair Kit for STJ330	7g	-0510K	255.00
Seal Repair Kit for STJ410	4g	-0500K	255.00

HAND TOOLS



Constructed from heavy gauge steel for heavy-duty use with a large diameter saddle for a secure hold under the jacking point. Extra long handle for easy access under bigger vehicles which also tilts and locks in three positions with a built-in handle mounted safety release to prevent accidental lowering of the load. A foot pedal pump and fine adjustment are fitted on the handle for optimum vehicle height. Automatic safety overload protection and rear toe plate for easy positioning.



Model Number	Max Load (kg/Tonne)	Min Height (mm)	Max Height (mm)	Saddle Ø (mm)	Handle Pieces (mm)	Handle Length (mm)	Chassis Length (mm)	Chassis Width (mm)	Chassis Height (mm)	Net Weight (kg)
T556	5,000/5	150	560	130	1	1,200	1,420	370	200	95.0
T1056	10,000/10	160	560	150	1	1,200	1,555	490	255	145.0

1 tonne (metric ton or t) = 1000kg.

1 ton (imperial ton) = 2240lbs (1016kg).

Model Number	Capacity	Order Code	Price/1 TB	Spares	Order Code	Price/1 TB
T556	5 Tonne	-6380K	32445.00	Description to suit T556 & T1056	-7800K	5665.00
T1056	10 Tonne	-6420K	56603.00			

500kg Engine Support Beam

For supporting and accurately positioning engines during maintenance operations and as an aid for the removal of gearboxes and transmissions. 500kg (½ tonne) capacity. Adjustable width to bridge various engine compartments. Fitted with soft rubber feet to protect the bodywork. Supplied with a 92cm long chain. Supporting legs can be tilted.

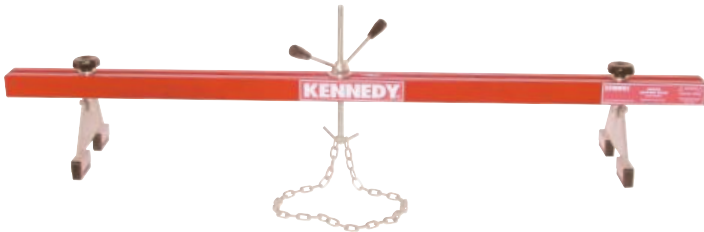

Type	Capacity	Weight each	Order Code	Price/1 TB
Engine Support	500kg		-8100K	7917.00

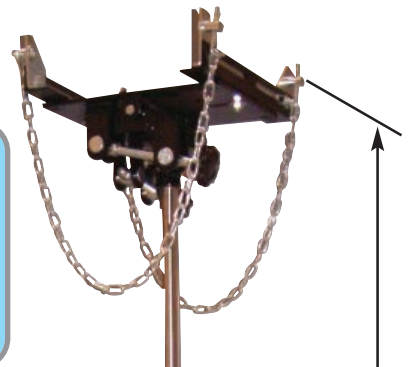

Telescopic Transmission Jack

Ideal for car and light commercial transmission removal and installation. Fully adjustable universal rotary saddle with adjustable corner brackets and safety chains. Foot operated pump and release valve leaves both hands free to manoeuvre transmission.

Wide base with four 3" dia. swivel-type ball bearing castors providing stability and easy manoeuvring. Two-stage flash chromed rams inhibit rust from entering the hydraulic system. Lifts from 875 to 1800mm.

Contents	TTJ500
Capacity	½ Tonne
Ram Extensions	2
Minimum Saddle Height	875mm
Maximum Saddle Height	1800mm
Saddle Size	680 x 810mm
Chain Length	95mm
Saddle Tilt Forward	24"
Saddle Tilt Back	19"
Saddle Tilt Side	±20"
Saddle Return Weight	15.8kg (35lbs)
Base	695 x 805mm
Weight	68.5kg

Model Number	Order Code	Price/1 TB
TTJ500	-7160K	40214.00

Description	Order Code	Price/1 TB
Seal Repair Kit	-8210K	1288.00

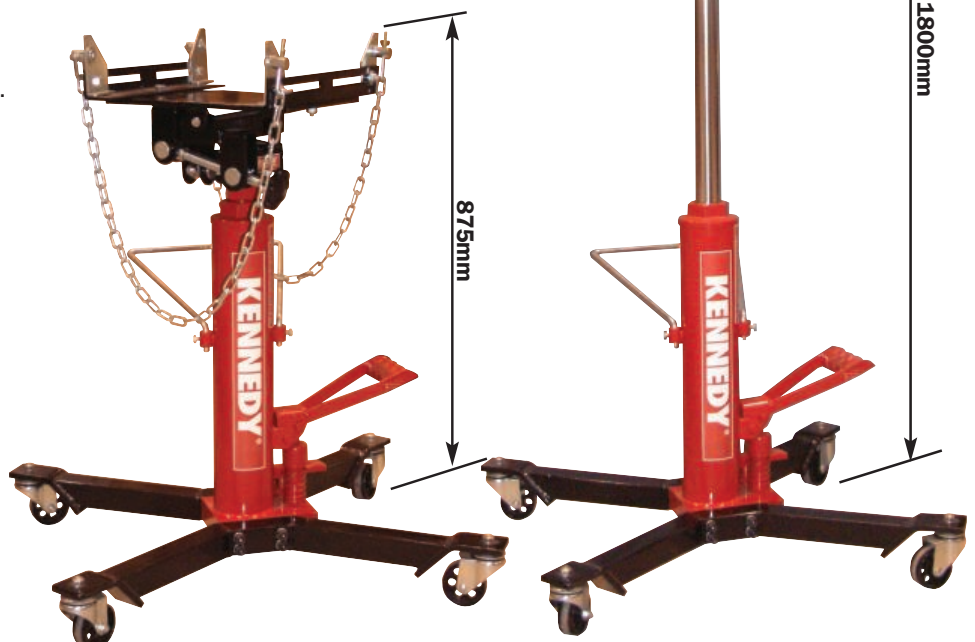

HAND TOOLS

KENNEDY *Hydraulic Nut Splitter Set*
QUALITY INDUSTRIAL TOOLING

The hydraulic ram provides up to 10 tonnes of direct non-twisting application of thrust that is more effective and secure than a mechanical thrust screw. Fully threaded body allows for quick and easy height adjustment. The splitter bodies are manufactured from carbon steel.

8 Piece Set contents:

- 1x hydraulic ram.
- 1x splitter body 3/8" diameter capacity.
- 1x splitter body 1/2" diameter capacity.
- 1x splitter body 5/8" diameter capacity.
- 1x splitter body 3/4" diameter capacity.
- 1x splitter body 1" diameter capacity.
- 1x threaded attachment sleeve.
- 1x oil bottle.



8
PIECES



Product Number	Weight each	Order Code KEN-503	Price/1 TB
HNS100	4.45kg	-4300K	13022.00

AUTOMOTIVE - NUT SPLITTERS

Nut Splitters

Mechanical drop forged, hardened and tempered plated steel. Ideal for releasing seized/damaged nuts etc.



Product Number	Capacity (mm/Inch)	Weight each	Order Code KEN-503	Price/1 TB
1	9 - 12 (3/8" - 1/2")	90g	-4090K	361.00
2	12 - 16 (1/2" - 5/8")	170g	-4160K	490.00
3	16 - 22 (5/8" - 7/8")	350g	-4220K	670.00
4	22 - 27 (7/8" - 1 1/16")	600g	-4270K	979.00

4 Piece Set

Contents (1 of each): No.1, No.2, No.3, No.4.

4
PIECES



Number of Pieces	Weight each	Order Code KEN-503	Price/1 TB
4	1.40kg	-4290K	2500.00

Parts Washers

Used in garage, workshop and industrial applications for degreasing components for inspection and prior to assembly. Recirculated cleaning fluid is filtered before entering the pump and being directed over the work piece. Flexible chrome finish metal delivery hose. Heavy duty non-welded one piece tank. Fully enclosed electric nylon pump. Self-latching fusible linked lid closes in the event of a fire. Triple baked enamel finish. Accepts all common degreasing agents. Shelf keeps parts out of solvent during inspection and drying. Immersion soaking when the parts shelf is removed. Fitted with a three pin moulded plug and a 1.6m power cable.

PWB013 - Bench Standing

Minimum agent capacity 9ltr. Maximum agent capacity 13ltr. Rubber feet. 240V

Overall size (L x W x H): 470 x 340 x 250mm.

Tank size (L x W x H): 400 x 310 x 230mm.

Power rating: 25W.

Voltage: 240V.

Rated input: 0.3A.



PWF050 - Floor Standing

Minimum agent capacity 40ltr. Maximum agent capacity 50ltr. Fitted with a drain plug for easy maintenance.

Removable parts basket.

Built in replaceable filter.

Spare filter included.

Overall size (L x W x H): 800 x 550 x 890mm.

Tank size (L x W x H): 725 x 490 x 270mm.

Height of working area: 750mm.

Power rating: 25W.

Voltage: 240V.

Rated input: 0.3A.



Replacement Parts

Description	Order Code KEN-567	Price/1 TB
Flexible Hose for PWB013	-6050K	424.00
Flexible Hose for PWF050	-6060K	530.00
Filter for PWB013	-8600K	208.00
Filter for PWF050	-8640K	239.00
Pump for PWF050/PWB013	-8700K	1433.00



Model Number	Weight each	Order Code KEN-503	Price/1 TB
PWB013	6.50kg	-8600K	4400.00

Model Number	Weight each	Order Code KEN-503	Price/1 TB
PWF050	31.0kg	-8640K	13196.00

PRODUCTS ARE ONLY AVAILABLE VIA YOUR DISTRIBUTOR

HAND TOOLS

GROUP 503 AUTOMOTIVE - OIL FILTER & SUMP TOOLS

KENNEDY Oil Drain Plug Key Set
QUALITY INDUSTRIAL TOOLING Key Set

DPK017

A comprehensive set of quality 3/8" square drive oil drain plug keys with tommy bar. Made from satin finished chrome vanadium.

Contents:

Male square: 7mm, 8mm (5/16"), 9mm, (3/8"), 10mm, 11mm, 12mm and 13mm. Female square: 10mm. Male hex: 8, 9, 10, 12, 14 and 17mm. Male triangular 10mm. Tommy bar.

**17
PIECES**



Product Number	Number of Pieces	Order Code KEN-503	Price/1 TB
DPK017	17	-1720K	2441.00

Strap Type Oil Filter Remover

Used for gripping round and irregular shaped items, tubes and piping. Ideal for oil filters, hot radiator caps and hub caps.

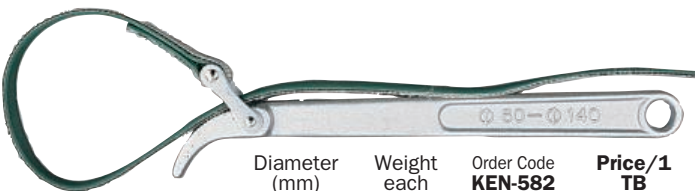

Diameter (mm)	Weight each	Order Code KEN-582	Price/1 TB
60 - 140	280g	-9500K	901.00

Chain Wrench Oil Filter Remover

Used for gripping round and irregular shaped items, tubes and piping. Ideal for oil filters, hot radiator caps and hub caps.

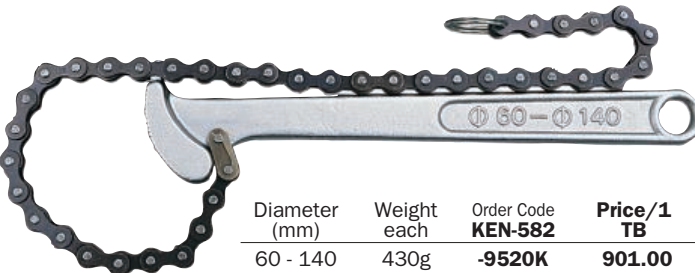

Diameter (mm)	Weight each	Order Code KEN-582	Price/1 TB
60 - 140	430g	-9520K	901.00

Oil Filter Pliers

Manufactured from hardened and tempered chrome vanadium with chemically blackened corrosion resistant finish and vinyl grip. Three position rapid jaw adjustment with high grip tooth profile, ensures the minimum amount of effort is required to remove or fit oil filters.

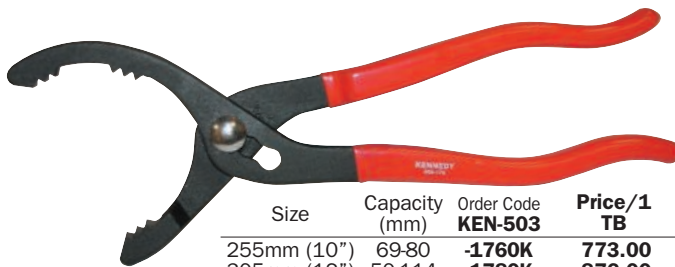

Size	Capacity (mm)	Order Code KEN-503	Price/1 TB
255mm (10")	69-80	-1760K	773.00
305mm (12")	50-114	-1780K	876.00

Oil Filter Cap Wrench Set

Cap type filter wrenches manufactured from chrome vanadium with a satin finish. Use with 3/8" or 1/2" square drive wrenches to remove paper cartridge style oil filters.

Contents: 24, 27, 30, 32, 36, 38mm and 1/2" - 3/8" adaptor.



**7
PIECES**



Diameter (mm)	Weight each	Order Code KEN-503	Price/1 TB
60 - 140	430g	-1790K	2653.00

Three Jaw Oil Filter Wrench

For use with ratchet handles, extension bars, flexible drives etc. With 3/8" square drive and hexagon adaptor, or use with 19mm/3/4" AF spanners or sockets. All steel construction, chrome plated with milled teeth on gripping arms for positive action when loosening or tightening.



Spread/Range	Weight each	Order Code KEN-503	Price/1 TB
60 to 120mm	600g	-1800K	737.00

SENATOR Oil Filter Wrench
QUALITY TOOLING Wrench

Articulated filter wrench with swivel action tightener. Suitable for oil filters with limited access.

Capacity: 75 - 110mm.



Capacity	Weight each	Order Code SEN-503	Price/1 TB
75 to 110mm	320g	-1800K	1214.00

HAND TOOLS



3 JAW

HAND TOOLS

KENNEDY Mechanical Puller - 2 Jaw

Industrial Reversible/Double-Ended Adjustable

Used for the removal of gears, ball races, bearings, pulleys and sprockets from a drive shaft. With reach capacities of 75, 100, 150 and 200mm.

All sizes have double-ended, adjustable, reversible legs and can be used for internal and external applications.

Selection

Always use a three jaw puller whenever possible. This produces better load distribution across the jaws and easier and safer removal of the part. Determine what 'spread' is needed this is the width of the part to be removed.

The reach capacity is determined by the depth of the part to be removed.

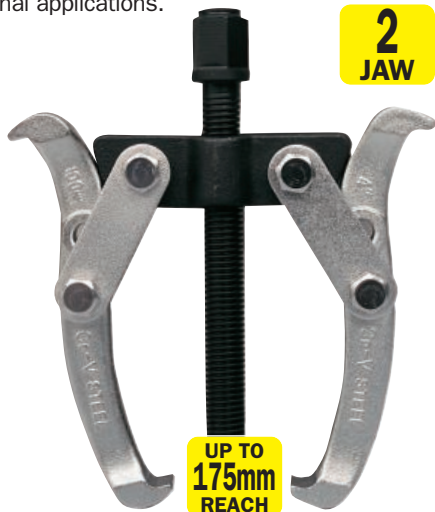

2 JAW

UP TO 175mm REACH

Product Number	Spread (mm)	Reach (mm)	Thread Length	Order Code KEN-503	Price/1 TB
MP275	40 - 75	60	125	-3030K	684.00
MP2100	50 - 100	70	160	-3040K	1040.00
MP2200	60 - 150	120	240	-3060K	1476.00
MP2150	80 - 200	175	335	-3080K	3165.00

Spare Jaws (Supplied individually)

To Suit Puller	Order Code KEN-567	Price/1 TB
MP275	-5330K	181.00
MP2100	-5340K	205.00
MP2200	-5360K	258.00
MP2150	-5380K	670.00

Mechanical Pullers

3-Jaw Industrial Reversible Double-Ended Adjustable

Manufactured from drop forged chrome vanadium steel.



UP TO 175mm REACH

Product Number	Spread (mm)	Reach (mm)	Thread Length	Order Code KEN-503	Price/1 TB
MP375	40 - 75	60	125	-3130K	957.00
MP3100	50 - 100	70	160	-3140K	1313.00
MP3150	60 - 150	120	240	-3160K	2185.00
MP3200	80 - 200	175	335	-3180K	4126.00

Spare Jaws

To Suit Puller	Order Code KEN-567	Price/1 TB
MP375	-5330K	181.00
MP3100	-5340K	205.00
MP3150	-5360K	258.00
MP3200	-5380K	670.00

Long Reach Mechanical Puller - 2 Jaw

Reversible

Manufactured from drop forged hardened alloy steel. Three position extra long legs to be used where access is limited.

The puller legs are securely located on the bearing by screwing down the tapered nut to lock the arms in position. The legs are then retracted with the bearing by turning the T-bar to extend the thrust bolt on to fixed shaft.

Spread: 10 - 50mm.
Reach: 300mm.



2 JAW

300mm REACH

EXTRA LONG

Reach	Weight each	Order Code KEN-503	Price/1 TB
300mm	1.20kg	-3320K	3116.00

Mechanical Puller - Industrial Kits

2 & 3 Jaw Reversible/Double-Ended/Adjustable

Manufactured from chrome vanadium steel. Each kit contains the components to assemble a 2 or 3 jaw external or internal puller. The legs can be set at two different height positions.



Inner and outer reversible, two height position jaws

Drive screw

x3

Pivot bolt

x6

Two jaw yoke

Three jaw yoke

Connecting plate

Assemble to produce:

Three jaw external configuration.



2&3 JAW

UP TO 200mm REACH

Spread (mm)	Reach (mm)	Thread Length	Order Code KEN-503	Price/1 TB
41 - 53	75	80	-3230K	1176.00
40 - 87	100	100	-3240K	1640.00
60 - 139	150	165	-3260K	2619.00
80 - 194	200	240	-3280K	4803.00

Spare Jaws (Supplied individually)

To Suit Puller	Order Code KEN-567	Price/1 TB
41 - 53mm	-5330K	181.00
40 - 87mm	-5340K	205.00
60 - 139mm	-5360K	258.00
80 - 194mm	-5380K	670.00

PRODUCTS ARE ONLY AVAILABLE VIA YOUR DISTRIBUTOR

GROUP 503 AUTOMOTIVE - PULLERS & SEPARATORS

KENNEDY *Bearing Separators*
QUALITY INDUSTRIAL TOOLING

For removing bearings, gears and bushes from shafts where access with a mechanical puller is restricted. Separators have tapered edge for insertion behind close fitting bearings, gears and bushes.

Jaw hardness: 42° - 45° HRC.

UP TO 150mm CAPACITY

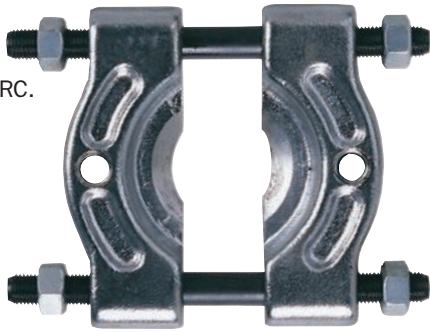

Product Number	Capacity (mm)	Order Code KEN-503	Price/1 TB
BS50	30 - 50	-4520K	1085.00
BS75	50 - 75	-4540K	1448.00
BS105	75 - 105	-4560K	2049.00
BS150	105 - 150	-4580K	5655.00

Mechanical Separator Set

30 - 75mm

For removing bearings, gears, sprockets and bushes. Metal storage case.

Contents:

- 1x 7" thrust bolt.
- 1x 30 - 50mm separator.
- 1x 50 - 75mm separator.
- 2x 80 and 100mm main rods.
- 2x 90 and 110mm extension rods.
- 1x beam.



8 PIECES

Product Number	Weight each	Order Code KEN-503	Price/1 TB
MS12	4.95kg	-4750K	5027.00

Ball Joint Separators

Manufactured from drop forged alloy steel with slim tapered fork jaw for easier access into confined areas. Suitable for use on most car and light commercial vehicle ball joints.

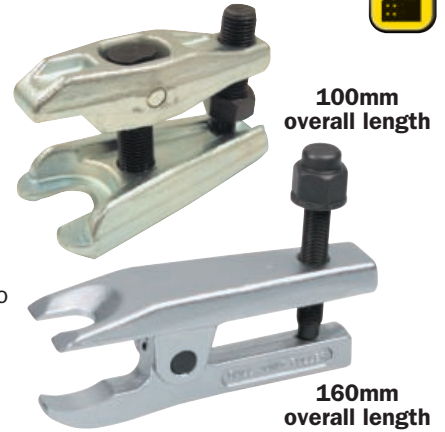

100mm Overall Length - Restricted Access

Designed for use in hard to reach and confined areas. Mainly for use on Asian import cars.

Overall Length	Capacity	Throat Depth	Throat Width	Weight each	Order Code KEN-503	Price/1 TB
100mm	22mm	22mm	22mm	740g	-1400K	1486.00
160mm	45mm	22mm	18mm	1.120g	-4400K	2351.00

Ball Joint Servicing Kit

Made from cast iron and hardened carbon steel, this kit is designed for the removal of press fit type ball joints without having to remove the control arm from the vehicle. The kit can also be used for removing brake anchor pins and the servicing of universal joint bearings.



Description	Weight each	Order Code KEN-503	Price/1 TB
Ball Joint Servicing Kit	7.60kg	-1300K	6850.00

Spring Compressor Sets

Hardened steel screws and cast steel claws.

2 Legged

Central hexagonal drive with wrap over coil claws which can be reversed for spreading applications. Suitable for use on cars and light commercial vehicles.

Use with 21mm/¹³/₁₆" AF open ended spanner.

Maximum jaw opening: 250mm.

3 Legged

Each leg has one free moving claw and one threaded claw with a 1/2" square drive or 24mm hexagon drive - can be used with air tools or spanners. Fitted with safety hooks to prevent accidental release. Suitable for use on cars and commercial vehicles and allows safe compression of heavier springs.

Maximum jaw opening: 240mm.

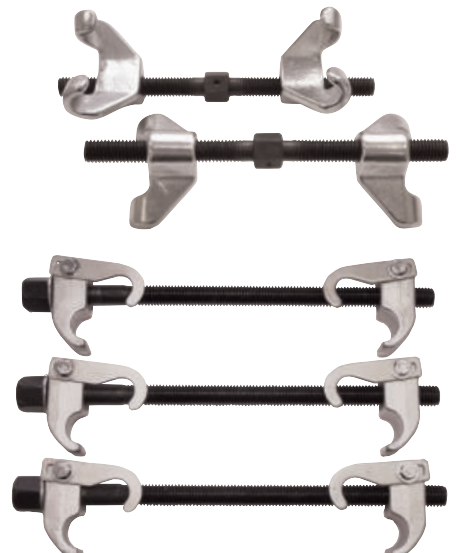

Product Number	Number of Legs	Weight each	Order Code KEN-503	Price/1 TB
CCD225	2	1.20kg	-2410K	1531.00
CCD324	3	3.00kg	-2420K	2946.00

HAND TOOLS



KENNEDY *6 Way Hydraulic Puller Set*
QUALITY INDUSTRIAL TOOLING

10 ton capacity hydraulic ram with tommy bar.
 Supplied with three position puller legs covering a spread of 100 - 240mm and reach of 0 - 150mm.
 Can be used as a two or three legged puller with the same head.

Contents:

- 1x combination head.
- 1x hydraulic ram.
- 3x three position puller legs.
- 6x leg connectors.
- 6x screw nuts, bolts and washers.
- 1x 50mm extension rod.
- 1x centre adaptor.
- 1x blow moulded storage case.



Hydraulic Separator Sets

HS7 105 - 150mm

HS11 75 - 105mm

For removing bearings, gears, sprockets and bushes.
 10 ton capacity hydraulic ram with tommy bar. Metal storage case.

Both sets contain:

- 1x hydraulic ram.
- 1x separator.
- 2x 200mm main rods.
- 2x 230mm extension rods.
- 1x beam.
- 1x ram nut.
- HS7 (only) also contains
- 1x 80mm push plate.
- 1x 50mm ram extension.
- 1 x 100mm ram extension.

**8
PIECES**



HS7 Set Illustrated

Product Number	Weight each	Order Code KEN-503	Price/1 TB
HS7	15.0kg	-4700K	11364.00
HS11	9.30kg	-4720K	9397.00

Hydraulic Puller/ Separator Set

10 ton capacity hydraulic ram with tommy bar.
 Suitable for agricultural machines, garage and industrial use.

Contents:

- 1x hydraulic ram (KEN- 503-7200K).
- 3x 4", 6" and 8" puller legs.
- 1x twin head.
- 1x triple head.
- 1x 50mm ram extension.
- 1x 100mm ram extension.
- 2x 200mm main rods.
- 2x 230mm extension rods.
- 1x 75 - 105mm separator.
- 1x bolt.
- 1x ram ring. 1x ram nut.
- Blow moulded storage case.

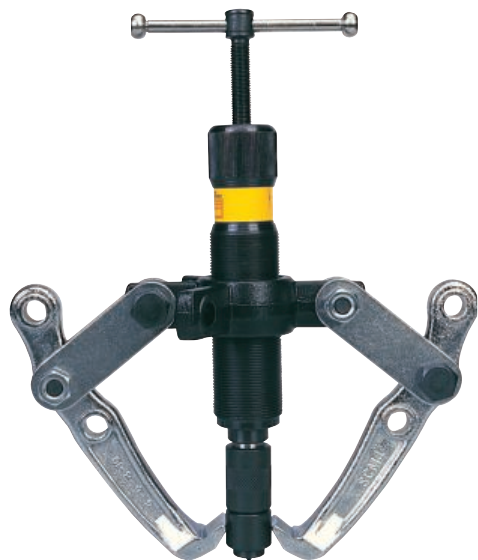

**2&3
JAW** **250mm
REACH**

Model Number	Weight each	Order Code KEN-503	Price/1 TB
HP19	4.90kg	-3500K	7596.00

Hydraulic Ram

10 ton capacity grease filled hydraulic ram with spring loaded plunger. Provides direct non-twisting application of thrust that is more effective and secure than a mechanical thrust screw.
 Fully threaded body allows for quick and easy height adjustment.



Model Number	Weight each	Order Code KEN-503	Price/1 TB
HR10T	1.40kg	-7200K	2924.00

Model Number	Order Code KEN-567	Price/1 TB
Seal Repair Kit	-8230K	464.00



Model Number	Weight each	Order Code KEN-503	Price/1 TB
HPS22	16.0kg	-3520K	12431.00

HAND TOOLS

SWP9 Steering Wheel

Suitable for GM, Ford and Chrysler vehicles. Also suitable for removing pulleys and fly wheels.

Contents:

- 1x yoke,
- 1x thrust bolt.
- 1x thrust cap.
- 2x 75mm screws (5/16" x 24 UNF).
- 2x 75mm screws (3/8" x 16 UNC).
- 2x 90mm screws (5/16" x 18 UNC).
- 1x plastic storage tray.



HPB9 Harmonic Balance

For harmonic balance removal, timing gears and other parts with bolt circle diameters from 38 to 117mm (1 1/2" to 4 5/8").

Ductile steel yoke.

Contents:

- 1x yoke.
- 1x thrust bolt.
- 1x ram nut.
- 3x 75mm screws (3/8" x 24 UNF).
- 3x 75mm screws (3/8" x 16 UNC).
- 1x plastic storage tray.



CP18 Combination

Steering wheel puller suitable for GM, Ford and Chrysler vehicles.

For harmonic balance removal, timing gears and other parts with bolt circle diameters from 38 to 117mm (1 1/2" to 4 5/8").

Contents:

As SWP9 and HPB9 above.



Model Number	Weight each	Order Code KEN-503	Price/1 TB
SWP9	1.00kg	-3400K	723.00
HPB9	1.80kg	-3420K	1225.00
CP18	2.75kg	-3440K	2016.00

Slide Hammer Puller Set

Multi-function

Fully hardened and chromed carbon steel slide hammer with a 1.2kg weight. Slide hammer design for removing bearings from blind housings. Suitable for use where a shaft or other solid surface is not available for a thrust bolt or hydraulic ram to push against. The bearing is removed by the impact action of the slide hammer weight hitting the stop at the end of the bar. The puller legs are securely located on the bearing by screwing down the tapered nut to lock the arms in position. Blow moulded storage case.

Contents:

- 1x T-bar.
- 1x hammer.
- 1x two jaw head.
- 1x three jaw head.
- 1x leg locking nut.
- 1x grip wrench adaptor.
- 1x tapping adaptor and hook.
- 2x axle pullers.
- 3x 120mm puller legs,
- 3x screw and nut assemblies.
- 1x blow moulded storage case.



15 PIECES

2&3 JAW



2 Jaw External



3 Jaw External

3 Jaw Internal

2 Jaw Internal

Model Number	Weight each	Order Code KEN-503	Price/1 TB
SHP8	8.20kg	-3480K	5437.00

Slide Hammer Puller Set

3 Jaw Internal & External Multi-function Slide Hammer Puller Set



Fully hardened and chromed carbon steel slide hammer with a 1.2kg weight. Slide hammer design for removing bearings from blind housings.

Suitable for use where a shaft or other solid surface is not available for a thrust bolt or hydraulic ram to push against. The bearing is removed by the impact action of the slide hammer weight hitting the stop at the end of the bar. The puller legs are securely located on the bearing by screwing down the tapered nut to lock the arms in position. Blow moulded case.

6 Piece Set Contents:

- 1x T-bar.
- 1x hammer 1.2kg.
- 1x 3 jaw internal puller 15 - 30mm.
- 1x 3 jaw internal puller 30 - 80mm.
- 1x 3 jaw external puller 15 - 80mm.
- 1x blow moulded case.

6 PIECES



3 JAW



Model Number	Weight each	Order Code KEN-503	Price/1 TB
IEP	4.95kg	-3340K	8087.00

KENNEDY PROFESSIONAL Advance Timing Light

For checking and setting ignition timing on automotive, agricultural and marine engines. Measures ignition spark advance from 0 - 60°. For use on 12V systems. Reverse polarity protected. Accurate to 8,000rpm. 1m long removable coiled power leads. Impact resistant metal case and rubber nose cone. On/off trigger switch. Bright linear Xenon flash tube for daylight use. Focused lens provides a concentrated light. Easy to apply inductive impulse pick-up. Built in check light.

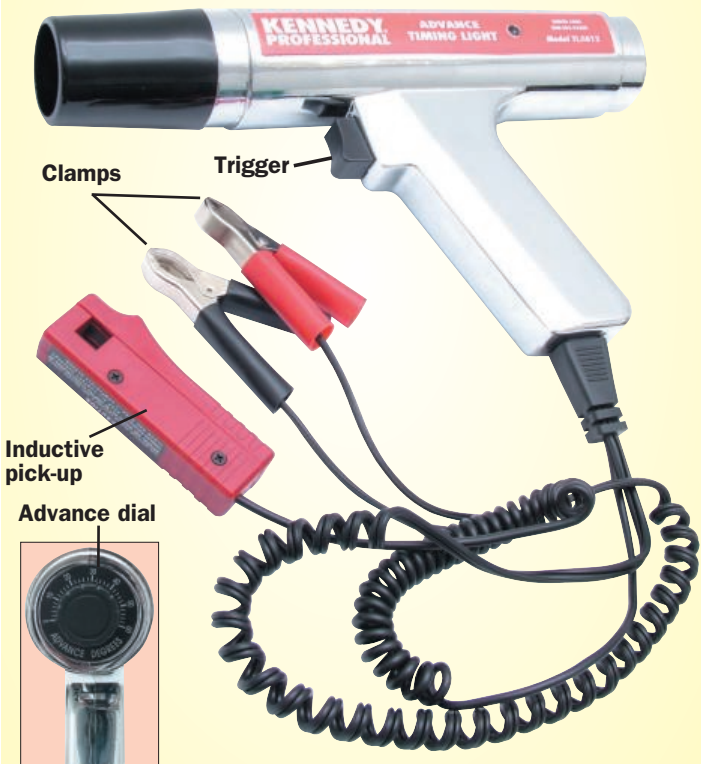

Description	Order Code	Price/1 TB
Advance Timing light	KEN-503 -5320K	7814.00

KENNEDY Standard Timing Light

For checking and setting ignition timing on automotive, agricultural and marine engines. For use on 12V systems. Reverse polarity protected. Accurate to 8,000rpm. 135cm long durable power leads. Impact resistant housing. On/off trigger switch. Bright linear Xenon flash tube for daylight use. Focused lens provides concentrated light. Easy to apply inductive impulse pick-up.



Description	Order Code	Price/1 TB
Standard Timing light	KEN-503 -5340K	4864.00

HAND TOOLS

Noid Light 6 Piece Test Set

NLT060
The Kennedy® Noid light test set is for diagnosing fuel injector signal faults fast. Simply disconnect the injector harness and plug in the relevant noid light. Turn the ignition on - if the light is constant or absent, then the signal from the ignition system is at fault. Easy to use and fits a wide variety of injector harnesses.

Compatible with: GM - TBI, GM - SCPI, GM - PFI, FORD - TBI, GEO - TBI, BOSCH - PFI.



6 PIECES

Product Number	Number of Pieces	Order Code	Price/1 TB
NLT060	6	KEN-503 -5020K	541.00

PRODUCTS ARE ONLY AVAILABLE VIA YOUR DISTRIBUTOR

KENNEDY Automatic Battery Chargers
QUALITY INDUSTRIAL TOOLING

Robust battery charger suitable for home and light workshop use. Simple and easy to use. LED indicators. For WET batteries, AGM technology and GEL batteries. Optimised charging programme. Efficient 3 stage charge. 100% rated output. Portable and lightweight. Intelligent circuit control and protection.

KBC4A
Input: 220-240V 50hz 0.65A
Output: 12VDC 1A/12VDC 4A
Net Weight: 760g

KBC8A
Input: 220-240V 50hz 0.80A
Output: 6VDC 1A/12VDC 8A
Net Weight: 760g



Model Number	Maximum Rated Current	Order Code KEN-503	Price/1 TB
KBC4A	4A	-0320K	2575.00
KBC8A	8A	-0350K	2833.00

KENNEDY Booster Cables
QUALITY INDUSTRIAL TOOLING

For use on cars and light commercial vehicles, these high quality copper coated aluminium cables are colour coded (Red = positive, Black = negative) and feature fully insulated clamps.

400A: 16mm diameter cable suitable for use on up to 2.5L petrol/1.5L diesel vehicles
500A: 25mm diameter cable suitable for use on up to 5.5L petrol/3.0L diesel vehicles
 Storage bag supplied.



Amp Rating	Cable Length	Order Code SEN-503	Price/1 TB
300	2.5m	-1250K	550.00

SENATOR Booster Cables
QUALITY TOOLING

For use on cars and light commercial vehicles, these high quality, light duty copper coated aluminium cables are colour coded (Red = positive, Black = negative) and feature fully insulated clamps.

300A: 10mm diameter cable suitable for use on up to 1.5L petrol vehicles.
 Storage bag supplied.



Amp Rating	Cable Length	Order Code KEN-503	Price/1 TB
400	3.5m	-5360K	750.00
500	4.5m	-5370K	850.00

Steel Jerry Cans

Manufactured from 16 swg steel. Suitable for storing petrol. Suitable for storing and transportation of diesel, paraffin and motor oil. With lever type safety sealing cap and integral carrying handle. Painted outside and phosphated internally.

UN Approved, Class 3.



Capacity	Order Code KEN-503	Price/1 TB
5ltr	-9270K	1530.00
10ltr	-9260K	1639.00
20ltr	-9250K	2029.00

Metal Spouts For Jerry Can

Capacity	Order Code KEN-503	Price/1 TB
5 & 10ltr	-9300K	821.00
20ltr	-9320K	821.00

5ltr Fuel Containers

Suitable for transporting and storage of petroleum spirit and diesel. UN approved, conforms with S.I. 1982/630 Petroleum Spirit Plastic Container Regulations 1982.

Colour coded for use with different fuel types.



Colour	Weight each	Order Code KEN-503	Price/1 TB
Red	630g	-9010K	493.00
Green	630g	-9020K	493.00
Black	630g	-9030K	493.00

Non-Approved Fuel Containers

Durable polyethylene containers. Diesel, petrol, chemical and oil resistant. Integral rigid dispensing spout.



Capacity	Weight each	Order Code KEN-503	Price/1 TB
5ltr	320g	-9100K	629.00
10ltr	500g	-9120K	957.00
20ltr	755g	-9140K	1296.00

Steel Fuel Can

Manufactured from heavy gauge steel with an epoxy coated finish. Supplied with a flexible polythene vented pouring spout. Suitable for storage and transportation of petroleum spirit. Tested to DIN 7274, complies with UN Class 3.



Capacity	Weight each	Order Code KEN-503	Price/1 TB
10ltr	1.90kg	-9200K	1831.00

KENNEDY *Mini Air Compressor/ Pressure Gauge/Tyre Inflator*
QUALITY INDUSTRIAL TOOLING

For inflating tyres, airbeds, boats, sports equipment and any other inflatable products. Complete with 3m of cable 12V car cigarette lighter plug, nozzles and adaptors. The dual air pressure gauge can be read in both lb/in² and kg/cm². 300psi.



Voltage	Weight each	Order Code	Price/1 TB
12	1.3kg	KEN-503 -2500K	1384.00

Air Line Tyre Inflator

This push on type tyre inflator is robust and has a dial type pressure gauge reading up to a maximum of 170psi. The pressure gauge is protected from accidental damage by a rubber shock guard.



Max. Pressure Reading	Weight each	Order Code	Price/1 TB
170psi	720g	KEN-503 -8480K	2946.00

Heavy Duty Air Line Tyre Inflator with Gauge

This heavy duty push on inflator is of rugged construction and has a clear view integral pressure gauge reading from 10 - 120psi.

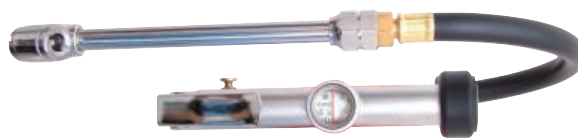

Max. Pressure Reading	Weight each	Order Code	Price/1 TB
120psi	635g	KEN-503 -8520K	2476.00

Deluxe Type Tyre Pressure Gauge

Manufacturer's recommended pressures are based on cold tyre readings. This pressure gauge has a long body, ideal for use on cars, vans, lorries, plant and equipment. It is very robust in construction and has a maximum pressure reading of 120psi.



Max. Pressure Reading	Weight each	Order Code	Price/1 TB
120psi	230g	KEN-503 -8430K	1088.00

SENATOR *Single Cylinder Foot Pump*
QUALITY TOOLING

Steel barrel, preset pressure gauge, rubber foot-rest pad. Standard thumb-lock connector. 24" hose length.

Capacity: 0 - 7bar/ 0 - 7kgf cm² (100psi).



Capacity	Weight each	Order Code	Price/1 TB
0 - 7 bar	1.1kg	SEN-503 -5350K	483.00

Fluorescent Warning Triangle

Manufactured from ABS plastic. This simple folding design combines a sturdy four footed base with its rubber grip feet and a high visibility interlocking triangle conforming to European Standard **ECE R27** and tested to **E1** specifications. Supplied in a low profile plastic carrying case.

Triangle dimensions: 440mm (each side).
Triangle height: 380mm.



Description	Order Code	Price/1 TB
Warning Triangle	KEN-503 -8400K	493.00

Pencil Type Tyre Pressure Gauge

This push-on gauge is suitable for cars, vans and light commercials, where readings of up to 120psi are necessary. It is of chrome plated brass construction with a pen type pocket clip.



Max. Pressure Reading	Weight each	Order Code	Price/1 TB
120psi	43g	KEN-503 -8460K	280.00

4000kg Elasticated Tow Rope

Model TRE400
 Two zinc plated steel safety hooks. Elasticated core minimises drag on overrun. Heavy duty stitched webbing. On tow sign. Manufactured to **BS AU 187 1983**.
Extended length: 4m.



Length	Order Code	Price/1 TB
4m	KEN-503 -8240K	1689.00

2000kg Tow Rope

Model TRP200
 Zinc plated steel safety hook. Looped one end. Manufactured from tough high visibility polypropylene. On tow sign. Manufactured to **BS AU 187 1983**.
Length: 3.6m.



Length	Order Code	Price/1 TB
3.6m	KEN-503 -8220K	712.00

Dial Type Tyre Pressure Gauges

This push-on type pressure gauge is graduated in psi and bar up to a maximum of 64psi (4.5bar). The reading is held until the release button is pressed.



Max. Pressure Reading	Weight each	Order Code	Price/1 TB
64psi	125g	KEN-503 -8440K	367.00

4-Way Tyre Valve Service Tool

This case hardened tool is for the internal and external repair of valve threads, insertion and removal of valve cores.

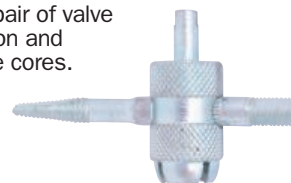

Type	Order Code	Price/1 TB
4-Way Tyre Valve Service Tool	KEN-503 -8500K	94.00

Tyre Tread Depth Gauge

This handy sized tyre depth gauge is graduated in mm and 1/32" and comes with a pen type pocket clip.



Graduation	Weight each	Order Code	Price/1 TB
mm & 1/32"	25g	KEN-503 -8450K	215.00

SENATOR *Telescopic Wheel Wrench*
QUALITY TOOLING

Manufactured from drop forged chrome vanadium steel. Supplied with 17/19mm double ended socket that will fit the majority of car wheel nuts. Can be used with any other 1/2" drive accessories. Extends to 500mm overall to give maximum leverage. **GS and TUV approved.**



Drive	Weight each	Order Code	Price/1 TB
1/2"	1.00kg	SEN-503 -9000K	703.00

HAND TOOLS

GROUP 503 AUTOMOTIVE - SPECIAL TOOLS

KENNEDY *Cleaning & Decarbonising Brush Set*
QUALITY INDUSTRIAL TOOLING

20-Piece

This cleaning brush set is very versatile in use as it comes with three different material bristles and can be used either manually or with a power drill.

Contents:

Quick release screwdriver, quick release extension bar,
 9, 11, 13, 15, 17 & 19mm Ø Brass Brushes,
 9, 11, 13, 15, 17 & 19mm Ø Steel Brushes,
 9, 11, 13, 15, 17 & 19mm Ø Nylon Brushes.

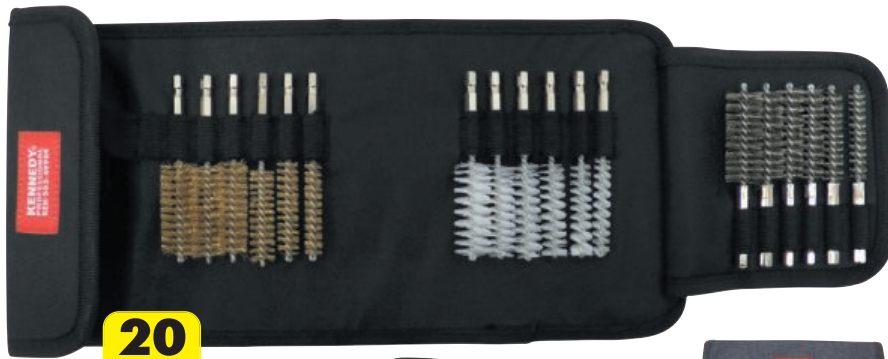

**20
PIECES**



Type	Number of pieces	Order Code KEN-503	Price/1 TB
Cleaning & carbonising brushes	20	-4990K	1914.00

Standard Length Gasket Scraper Set

Rigid carbon scrapers ideal for cleaning cylinder heads, removing old sealants, carbon build up and a variety of general multi-purpose automotive applications.

Set includes blade lengths:

205 x 13mm (8" x 1/2"),
 205 x 25mm (8" x 1"),
 93 x 25mm (3 1/2" x 1"),
 97 x 15mm (3 3/4" x 5/8").

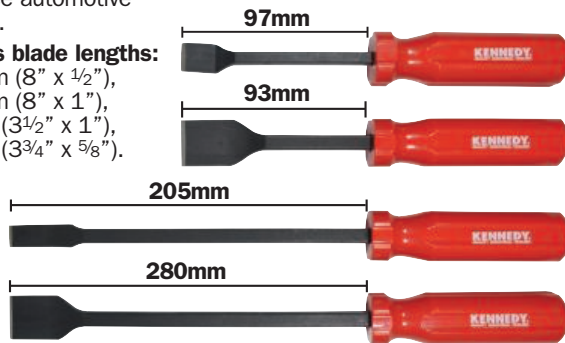

**4
PIECES**

Number of Pieces	Weight each	Order Code KEN-503	Price/1 TB
4	1.10kg	-1980K	1906.00

Gasket Scraper Set

Long Handled Gasket Scraper Set

For cleaning cylinder heads and removing old sealants and carbon build up. Hardened and tempered carbon steel shanks and heads are 'offset to edge' to allow easy scraping of flat surfaces. Simple 'firmer' style bevelled points with longer head lengths allow for scrapers to be re-ground several times for maximum service life. Impact resistant square section handle for secure grip even when greasy. Set includes blade widths: 19mm (3/4"), 25mm (1") and 38mm (1 1/2").

Overall length: 280mm (11").

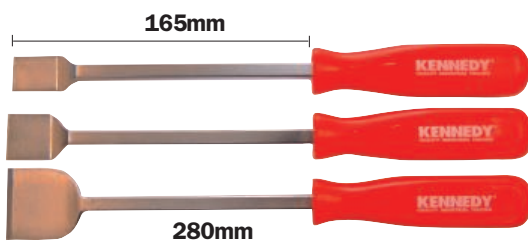

**3
PIECES**

Model Number	Weight each	Order Code KEN-503	Price/1 TB
GSL338	530g	-1700K	1087.00

Spark Plug Brush Set

Set of three: nylon, brass and stainless steel.



**3
PIECES**

Type	Order Code KEN-503	Price/1 TB
Spark Plug Brushes (Set of 3)	-5000K	280.00

Spark Plug Hole Thread Chaser

Double ended for 14mm and 18mm plug hole threads. Cleans corrosion and carbon build-up from female spark plug threads and sensor sockets.

Repairs minor cross threading damage. Use with 21mm deep socket



Type	Order Code KEN-503	Price/1 TB
Spark Plug	-2750K	308.00

HAND TOOLS

Glow Plug Socket Set

GPS060

A comprehensive set of quality glow plug sockets with universal joints for use in awkward areas. Made from satin finished chrome vanadium with a neoprene insert to grip and protect the plug.

Contents: 8, 9, 10, 12, 14 and 16mm.

**6
PIECES**



Product Number	Number of Pieces	Order Code KEN-503	Price/1 TB
GPS060	6	-1740K	2228.00

Professional Glow Plug Connector Pliers

Suitable for the removal of hard to reach glow plug connectors found on the latest generation of engines. Made from chrome vanadium steel. Composite handle provides added comfort and control.

Blade length: 125mm.

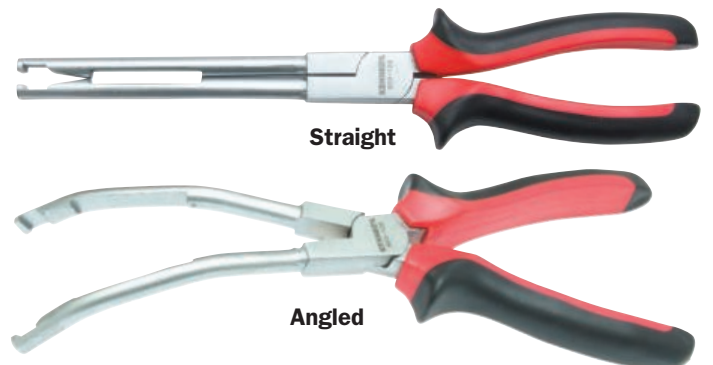

Jaw Type	Order Code KEN-503	Price/1 TB
Straight	-1240K	1327.00
Angled	-1260K	1433.00

KENNEDY *Oxygen 'EGO', 'O2', 'Lambda' Sensor Socket Set*
QUALITY INDUSTRIAL TOOLING

**3
PIECES**

Three piece universal set. Essential for servicing today's computer-controlled vehicle systems. Easily removes exhaust gas oxygen sensors (known as 'EGO', 'O2' or 'Lambda' sensors), vacuum switches and pressure switches. Also suitable for diesel injectors found on Mitsubishi, Nissan, Opel, Vauxhall and VW vehicles. Made from heat treated cast steel.

Set contains:

22mm (7/8") hex, 1/2" square drive socket with 7.5mm side slot for sensor wire clearance. Socket has 22mm hex for use with a spanner.

Overall length: 80mm.

22mm (7/8") hex, crow's foot style wrench, 1/2" square drive (double square for easy access). With full length 11mm slot for total clearance of switch/sensor wire.

22mm (7/8") hex, crow's foot style wrench, 3/8" square drive.

With full length 8.6mm slot for total clearance of switch/sensor wire.



Description	Order Code KEN-503	Price/1 TB
Sensor Socket Set	-8020K	1494.00

Rear Axle Bush Installation Tool

For the in-situ installation of the rear axle mounting bushes on selected VW and Audi vehicles such as Audi A3, VW Bora and Golf IV.



Product	Order Code KEN-503	Price/1 TB
Rear Axle Bush Tool	-1550K	6366.00

Mondeo Sub-Frame Bush Installation & Removal Tool

For the removal/installation of rear sub-frame bushes in the Ford Mondeo. Can be used in situ, no need to remove sub-frame from vehicle.

Applications: Ford Mondeo 2001, 10/2000 onwards.

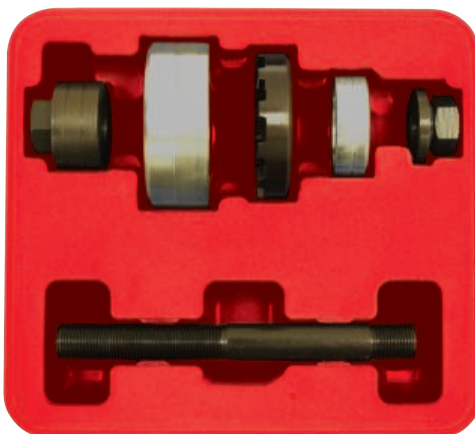

Product	Order Code KEN-503	Price/1 TB
Sub-Frame Bush Tool	-1540K	6896.00

Oxygen Sensor Socket

1/2" square drive. 22mm hex. x 90mm length. Cutaway section allows socket to pass over wiring.



Type	Order Code KEN-503	Price/1 TB
Oxygen Sensor Socket	-2760K	499.00

Viscous Hub Spanners

For the removal of thermal viscous fan hubs. Suitable for most makes of car.



Size (mm)	Weight each	Order Code KEN-503	Price/1 TB
32	325g	-1850K	567.00
36	315g	-1860K	567.00

Diesel Injection Pump Puller



For the removal of diesel injection pumps from the following engines:

DPP010



DPP020



DPP030



Product Number	Suitable for the following engines	Order Code KEN-503	Price/1 TB
DPP010	Landrover Freelander (Td4) & Rover 75 2.0d (M47R)	-1620K	1592.00
DPP020	BMW M47/57 Engines	-1630K	1910.00
DPP030	2.5TDS (BMW, Landrover, Vauxhall, OPEL)	-1640K	1433.00

Diesel Injector Removal Set Bosch/Delphi

Specifically designed for removing Delphi/Bosch injectors using 5/8" slide hammer. Set of three adaptors and a special tool for removing the internal part of Bosch injectors which can be used with an air tool to loosen the injectors through vibration.

**4
PIECES**



Type	Order Code KEN-503	Price/1 TB
Diesel Injector Removal Set	-1820K	2059.00

Diesel Injector Seat Cutter Set

Specifically designed for the cleaning and recutting of injector seats. For use with Bosch, Delphi, Iveco, Fiat and other universal applications.

Includes: five cutting reamers, pilot post, T-bar and a hexagon key.

**8
PIECES**



Type	Number of Pieces	Order Code KEN-503	Price/1 TB
Seat Cutter Set	8	-1830K	3089.00

KENNEDY Radio Release Master Set
QUALITY INDUSTRIAL TOOLING

RRM046

Radio release master set contains a comprehensive set of high quality tools suitable for authorised release and removal of in-car entertainment units. These professional tools, have a chromed finish and are manufactured from heavy-gauge materials to ensure these tools will not distort in general use. Supplied in foam lined aluminium carry case.

Compatible with the following makes of in-car entertainment units:

Audi, Becker, Becker from 2002, Blaupunkt, Blaupunkt from 2002, BMW, Clarion - New, Clarion - Old, Fiat Brava, Bravo & Marea, Grundig, JVC, Kenwood II to 2001, Kenwood III from 2002, Mercedes Benz, Opel, Opel-Inbus, Panasonic, Panasonic from 2006, Pioneer, Porsche, Skoda from 2002, Sony I to 2001, Sony II from 2002, VW.



**46
PIECES**

Product Number	Number of pieces	Order Code	Price/1 TB
RRM046	46	KEN-503 -1560K	7109.00

Magnetic Wing Cover

Designed to be used in the workshop to protect car wings when working. Manufactured from heavy duty vinyl with a soft backing to prevent any scratching or marking of paintwork when in use. The cover is held in place by magnets stitched into the material. Folds to a quarter of its length for storing.



Size (mm)	Weight each	Order Code	Price/1 TB
1100 x 400	810g	KEN-503 -7800K	1545.00

Anti-Freeze Tester

Suitable for use with Ethylene Glycol or Methanol type anti-freezes. Shows lowest temperature at which the cooling system is protected against freezing. Tough glass tube construction with an easy to read scale. For use on hot or cold engines.



Model Number	Weight each	Order Code	Price/1 TB
AFT001	140g	KEN-503 -1100K	501.00

Trim & Upholstery Tool Set

Five piece set of angled lever tools designed for the easy removal of vehicle trim fasteners, mouldings and wheel hubs. Ideal for use inside and outside the vehicle, the tools are manufactured from plastic to avoid marking and scratching metal, wood or upholstery material.



**5
PIECES**



Number of pieces	Order Code	Price/1 TB
5	KEN-503 -1510K	823.00

T-Handle Circlip® Tool

Fully adjustable internal and external Circlip® tool. Manufactured from hardened steel fitted with T-handle to give smooth precise control. Supplied with .090", .118", 0.150" and .170" interchangeable tips. 44 - 178mm capacity, ideal for use on commercial vehicles. **Overall length: 310mm.**



Overall Length	Order Code	Price/1 TB
310mm	KEN-503 -4980K	5531.00

Spare Tips

Tip Size	Order Code	Price/1 TB
0.090	KEN-567 -9100K	212.00
0.118	-9110K	212.00
0.150	-9120K	212.00
0.170	-9130K	212.00

Seal Puller Tool

Two size tips allow you to remove oil or grease seals from virtually anything including wheel bearings, transmission housings, etc. Hardened and tempered carbon steel shank and head with oxidised finish tips, chrome plated shank for protection against corrosion. Impact resistant square section handle for secure grip even when greasy. **Overall length: 310mm (12¼").**



Model Number	Weight each	Order Code	Price/1 TB
SPT312	365g	KEN-503 -2900K	469.00

Exhaust Doughnut Puller

To enable fast Installation or removal of rubber anti-vibration mounting rings found on modern exhaust systems. Puller has offset hook for easier application and dipped vinyl handle for added comfort and extra grip. Manufactured from hardened steel. **Length: 290mm.**



Model Number	Weight each	Order Code	Price/1 TB
EPD290	225g	KEN-503 -1600K	464.00

KENNEDY Heavy Duty Pry Bars
QUALITY INDUSTRIAL TOOLING

Manufactured from forged carbon heat treated steel with ground points. These traditional designs are ideal for use by tradesman in any industrial environment.

Rolling Head

Suitable for use in confined spaces.

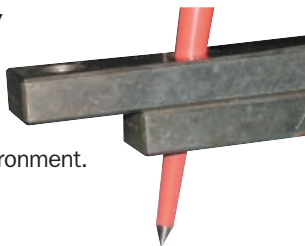

Length x Width	Order Code	Price/1 TB
150 x 10mm	-8400K	222.00
300 x 13mm	-8420K	441.00
450 x 16mm	-8440K	466.00

Line Type

Angled blade provides greater leverage.

Length x Section	Order Code	Price/1 TB
400 x 16mm	-8520K	603.00
600 x 20mm	-8560K	1070.00

Rolling Head Set

3 PIECES

Number of Pieces	Contents	Order Code	Price/1 TB
3	150mm Rolling head 300mm Rolling head 450mm Rolling head	-8780K	1635.00

Line Type Set

2 PIECES

Number of Pieces	Contents	Order Code	Price/1 TB
2	400mm Line Type 600mm Line Type	-8770K	1508.00

YAMOTO Chisel & Punch Set

14 PIECES

Chrome Vanadium Steel

Contents:

Pin punches: 3/16" x 6", 3/32" x 4 1/4", 1/8" x 4 3/4", 3/16" x 5 1/4" and 1/4" x 5 3/4".

Centre punches: 5/32" x 5".

Chisels: 1/2" x 6", 5/8" x 6 1/2", 3/4" x 7 1/2" and 7/8" x 8".

Taper punches: 3/16" x 10", 7/32" x 10", 5/16" x 10" and 3/8" x 10".



Number of Pieces	Contents	Order Code	Price/1 TB
14	Chisels & Punches	-9010K	2955.00

COLD CHISELS & PRY BARS

Plastic Handled Pry Bars



Made from square section chrome vanadium with ground points. Impact resistant plastic handles offer a more comfortable and secure grip to make these pry bars user friendly. Handles are oil and acid resistant.

Suitable for a wide range of general duty applications within the packing, automotive, maintenance and assembly industries.

Straight Blade

For general duty usage.



Blade Length x Width	Order Code	Price/1 TB
300 x 10mm	-8300K	848.00
450 x 13mm	-8320K	1334.00

Curved Blade

The curved blade provides greater leverage.

Blade Length x Width	Order Code	Price/1 TB
300 x 10mm	-8340K	895.00
450 x 13mm	-8360K	1406.00
600 x 13mm	-8380K	1674.00

Sets

Number of Pieces	Contents	Order Code	Price/1 TB
3	300mm Straight 300mm Curved 450mm Curved	-8330K	2942.00
2	450mm Curved 600mm Curved	-8390K	2077.00

Spot Weld Chisel & Bar

The Right Angled Seam Chisel and L Bar has been specially designed by Kennedy Tools for the separation of hard to reach spot welds and bonded panels as well as coping with the many traditional uses for pry and wrecking bars.

Features & benefits

- Easily separates hard-to-reach spot welded or bonded panels.
- Sharpened on three edges, the sharp end allows for penetration between the panels and both side edges allow for side impact to drive the panels apart without damage.
- 90° end for use in hard-to-reach pinchweld areas.
- Made from a super tough alloy steel.
- Will save the technician up to 15 minutes per panel replacement.

The Right Angled Rascal Bar with three sharpened edges is designed to allow two-directional hammer use on quarter panels, rockers and any other pinchweld. The chisel tip can be used for starting seam separation.



Description	Order Code	Price/1 TB
Chisel & Bar	-1200K	316.00

HAND TOOLS

GROUP 505 COLD CHISELS & PRY BARS



Cold Chisels - Chrome Vanadium



Manufactured from high quality octagonal chrome vanadium steel with a ground cutting edge, in accordance with **BS 3066**. For use on brickwork, masonry and cold metals.

Flat

Used for cutting and chipping cold metals and brickwork.

Flat Chisel Set



Number of Pieces	Contents (mm)	Order Code KEN-505	Price/1 TB
3	6 x 150, 12 x 200 & 18 x 255	-7150K	693.00
3	12 x 150, 18 x 200 & 25 x 255	-7160K	979.00

Brick Bolster - Chrome Vanadium

Used for splitting bricks.



Width x Length (mm)	Octagon (mm)	Order Code KEN-505	Price/1 TB
75 x 240	22	-7030K	561.00
100 x 240	22	-7040K	664.00

Flooring - Chrome Vanadium

Used for prising floorboards and cutting part of the board prior to lifting.



Width x Length (mm)	Octagon (mm)	Order Code KEN-505	Price/1 TB
56 x 230	16	-7120K	401.00

Pitching - Chrome Vanadium

For removing excess stone and facing, bevelled on one side.



Width x Length (mm)	Octagon (mm)	Order Code KEN-505	Price/1 TB
50 x 212	18	-6920K	900.00
62 x 212	22	-6930K	1176.00

Width x Length (mm)	Octagon (mm)	Order Code KEN-505	Price/1 TB
6 x 100	6	-1600K	140.00
6 x 150	6	-1620K	184.00
9 x 125	9	-2410K	153.00
9 x 150	9	-2460K	157.00
12 x 150	9	-3220K	190.00
12 x 200	9	-3240K	192.00
12 x 255	9	-3260K	176.00
12 x 305	9	-3280K	187.00
16 x 150	12	-4020K	192.00
16 x 200	12	-4040K	204.00
18 x 200	16	-4840K	294.00
18 x 230	16	-4850K	271.00
18 x 255	16	-4860K	326.00
18 x 305	16	-4870K	309.00
18 x 455	16	-4890K	398.00
25 x 200	22	-6440K	400.00
25 x 230	22	-6450K	504.00
25 x 255	22	-6460K	517.00
25 x 305	22	-6470K	536.00
25 x 355	22	-6480K	568.00
25 x 455	22	-6490K	818.00

Half Round - Chrome Vanadium

Used for channelling concrete floors.



Width x Length (mm)	Octagon (mm)	Order Code KEN-505	Price/1 TB
6 x 150	12	-6620K	243.00
18 x 200	18	-6640K	411.00

Cross Cut - Chrome Vanadium

Used for channelling brickwork.



Width x Length (mm)	Octagon (mm)	Order Code KEN-505	Price/1 TB
6 x 150	12	-6720K	258.00
9 x 200	18	-6740K	354.00

Diamond Point - Chrome Vanadium

Used for channelling brickwork.



Width x Length (mm)	Octagon (mm)	Order Code KEN-505	Price/1 TB
8 x 200	18	-6840K	411.00

Plugging - Chrome Vanadium

For removing cement mortar from between bricks.



Width x Length (mm)	Octagon (mm)	Order Code KEN-505	Price/1 TB
5 x 255	16	-7100K	428.00

HAND TOOLS



Contractor Flat Cold Chisels

Manufactured from high quality octagonal chrome vanadium steel with a ground cutting edge, in accordance with **BS 3066**. For use on brickwork, masonry and cold metals.



Width x Length (mm)	Octagon (mm)	Order Code SSF-505	Price/1 TB
12 x 200	11	-1060K	102.00
12 x 200 c/w guard		-1070K	205.00
18 x 200		-1100K	160.00
18 x 200 c/w guard	16	-1110K	258.00
18 x 255		-1120K	165.00
18 x 255 c/w guard	16	-1130K	308.00
25 x 200		-1160K	268.00
25 x 200 c/w guard	22	-1170K	361.00
25 x 255		-1180K	308.00
25 x 255 c/w guard	22	-1190K	411.00
25 x 305		-1200K	361.00
25 x 305 c/w guard	22	-1210K	428.00

Contractor Cross Cut Chisel

Chrome vanadium - used for channelling brickwork.



Width x Length (mm)	Octagon (mm)	Order Code SSF-505	Price/1 TB
6 x 150	12	-1260K	158.00

Contractor Brick Bolster Chisels

Chrome vanadium - used for splitting bricks.



Width x Length (mm)	Octagon (mm)	Order Code SSF-505	Price/1 TB
75 x 230	22	-1300K	371.00
75 x 230 c/w guard		-1310K	514.00
100 x 230		-1320K	593.00
100 x 230 c/w guard	22	-1330K	634.00

Contractor Electrician's Floor Chisels

Chrome vanadium - hardened and tempered cutting edge. For cutting the tongue in tongued and grooved floorboards.



Width x Length (mm)	Octagon (mm)	Order Code SSF-505	Price/1 TB
55 x 230	16	-1360K	411.00
55 x 230 c/w guard		-1370K	460.00



Manufactured from heat treated carbon steel. Ideal for dismantling timber constructions, opening packing cases and removing nails (depending on the type of bar).

Chisel and V-Notch Wrecking Bar

For general dismantling and stripping applications, within a wide range of industries.



Length	Order Code KEN-505	Price/1 TB
450mm	-7180K	384.00
600mm	-7240K	484.00
750mm	-7300K	539.00

Chisel and Point Crowbar

For heavy duty work.



Length x Width	Order Code KEN-505	Price/1 TB
900 x 38mm	-7360K	959.00
1200 x 42mm	-7480K	1386.00
1500 x 42mm	-7600K	2025.00

Heel and Point Crowbar

For heavy duty dismantling.



Length x Width	Order Code KEN-505	Price/1 TB
900 x 38mm	-7690K	959.00
1180 x 42mm	-7720K	1492.00
1500 x 45mm	-7750K	2185.00

Protector Sleeves

Contoured high impact resistant plastic grips redirects the force of miss-hits safely away from your hands preventing injury. Suitable for use with octagonal cold chisels.

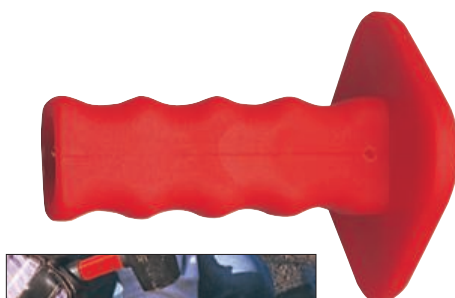

To Suit Octagon Size	Length (mm)	Order Code KEN-505	Price/1 TB
13mm	120	-9040K	268.00
16mm	120	-9050K	276.00
19mm	120	-9060K	291.00
22mm	120	-9070K	291.00

Super Lever Pry Bars

Multi purpose. Can be used as a nail lifter, pry bar, adze or lever.



Length x Width	Order Code KEN-505	Price/1 TB
325 x 33mm	-8200K	303.00
375 x 33mm	-8250K	338.00

Combination Sets

Containing one wrecking bar and one pry bar.



Contents	Order Code KEN-505	Price/1 TB
450mm Wrecking Bar, 325mm Pry Bar	-8750K	629.00
600mm Wrecking Bar, 375mm Pry Bar	-8760K	693.00

Scutch Holders - Carbon Steel

Used for chasing out and general masonry work.



Width x Length (mm)	Octagon (mm)	Order Code KEN-505	Price/1 TB
25 x 200	18	-6860K	1236.00
38 x 200	18	-6870K	1339.00

Detachable Bit

For scutch chisels and hammers.

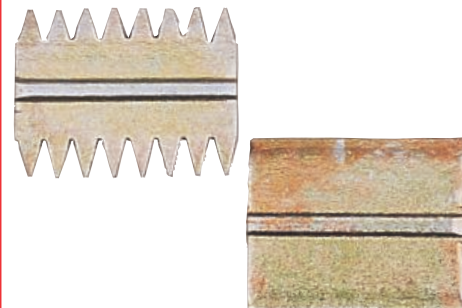

Comb Type	Width (mm)	Order Code KEN-505	Price/100 TB
Wide/Coarse	25	-9130K	2009.00
	38	-9140K	3039.00
Plain/Drove	25	-9230K	2009.00
	38	-9240K	3039.00

HAND TOOLS

GROUP 510 LEVELS

KENNEDY *Girder Section Levels*
QUALITY INDUSTRIAL TOOLING

Professional quality with three factory set vials, horizontal and two plumb, aluminium body with powder coat finish.

Accuracy: 0.75mm/m. Top face marked with metric and inch graduations. V-groove base for use on pipe work.



Length (mm)	Number of Vials	Weight each	Order Code KEN-510	Price/1 TB
400 (16")	3	295g	-1160K	603.00
900 (36")	3	600g	-1360K	1029.00
1000 (40")	3	710g	-1400K	1258.00
1200 (48")	3	850g	-1480K	1531.00

KENNEDY PROFESSIONAL *Box Section Spirit Levels*

Extruded aluminium body. Powder coated finish. Three high visibility vials: horizontal, plumb and 45°. Two rubberised handle grips and two milled working faces.

Accuracy: 0.5mm/m.

NEW



Length (mm)	Number of Vials	Weight each	Order Code KEN-510	Price/1 TB
300 (12")	3	390g	-3300K	670.00
600 (24")	3	650g	-3360K	876.00
800 (32")	3	960g	-3380K	979.00
1000 (40")	3	1.07kg	-3400K	1288.00
1200 (46")	3	1.27kg	-3420K	1545.00
1800 (72")	3	1.90kg	-3480K	2059.00

SENATOR *ABS Plastic Girder Section Level*
QUALITY TOOLING

Manufactured from impact resistant ABS plastic. Three vials horizontal, vertical and 45°. Metric and Inch graduated face.

Accuracy: 1mm/1000mm.



Length (mm)	Number of Vials	Weight each	Order Code SEN-510	Price/1 TB
610 (24")	3	290g	-2240K	505.00

Torpedo Level

With magnetic base. Made from impact resistant ABS plastic. Three vials horizontal, vertical and 45°.

Accuracy: ±1.0mm/m.



Length	Weight each	Order Code SEN-510	Price/1 TB
230 (9")	140g	-2090K	102.00

Boat Levels

Construction Boat Level

Die-cast aluminium frame with a milled measuring face for accuracy. 1 vertical, 1 horizontal vial for normal and upside down measuring. A very popular level with scaffolders. Includes leather belt pouch.

Accuracy: 1.0mm/m.



Base Type	Length (mm)	Weight each	Order Code KEN-510	Price/1 TB
Non-magnetic	250 (10")	185g	-0100K	575.00
Magnetic	250 (10")	185g	-0160K	761.00

Torpedo Level

Professional - with two factory set horizontal and angled vials which are shockproof to a tolerance of 1mm/m. Die cast zinc body with enamelled finish. V-groove on base.



Length	Weight each	Order Code KEN-510	Price/1 TB
230mm/9"	140g	-0090K	410.00

Line Level

This durable line level is made hard wearing plastic. With reversed line hooks for a positive hold and a pocket clip. 13mm (1/2") wide.



Length	Weight each	Order Code KEN-510	Price/1 TB
75mm (3")	45g	-2400K	102.00

Bullseye Level

Made from tough hard wearing plastic. Can be free standing, or fixed onto a surface. The all purpose Bullseye circular level will show level of any surface in all directions at once.

Height: 16mm.



Base Dia.	Level Dia.	Order Code KEN-510	Price/1 TB
50mm	32mm	-2100K	203.00

Magnetic Post Levels

Made from hard wearing plastic this specialist level designed to ensure both square and round posts are upright prior to permanent fixing. The right angle plate has two horizontal vials and one vertical vial with flush magnets for metal posts and an integrated elastic fixing strap for other materials.

Accuracy: ±1.0mm/m.

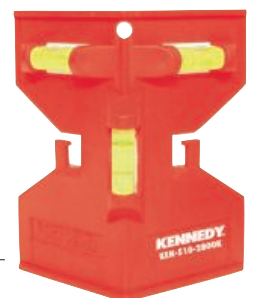

Overall Size	Weight each	Order Code KEN-510	Price/1 TB
75 x 125mm	87g	-2800K	164.00
85 x 140mm	87g	-2820K	205.00

HAND TOOLS



Extending Support Prop

This lightweight support prop is designed to give a helping hand when fixing overhead panelling and boarding. It has 125 x 80mm flat plates at both ends with a swivel ball joint for ease of use and to avoid damage to panel when pressure is applied. It has four pre-set adjustable height ranges: 1.16 to 2m, 1.46 to 2.3m, 1.76 to 2.6m, 2.06 to 2.9m.



Range	Order Code KEN-512	Price/1 TB
1.6 - 2.9m	-4000K	912.00



Plasterer's Hawk

With single screw fixing, zinc plated for corrosion protection. Heavy gauge sheet aluminium platform, highly polished, mirror finish. Suitable for DIY use.



Size (mm)	Weight per 10	Order Code SEN-512	Price/1 TB
265 x 265	6.20kg	-0920K	670.00

Plasterer's Trowel

Economy

Single tang, banana shaped handle with six concealed welded rivets to securely fix 'cross ground', hardened and tempered blade.

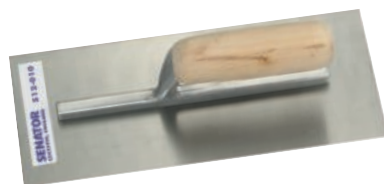

Size	Weight per 10	Order Code SEN-512	Price/1 TB
280mm (11")	4.60kg	-0100K	572.00



Paint & Plaster Mixer

Used for mixing plaster, concrete, filler, epoxy resin, emulsion paint and wallpaper paste. The stirring end should be fully immersed before the shaft is turned.

Light duty shaft: 8mm hex.
Overall length: 400mm.
Heavy duty shaft: 12mm hex.
Overall length: 600mm.

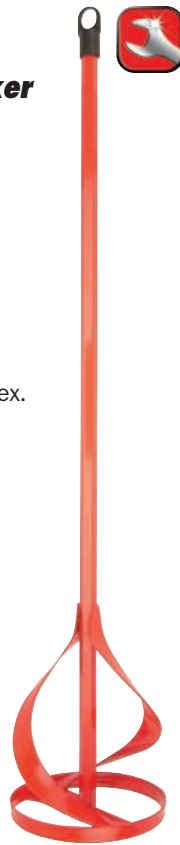

Shaft	Weight per 10	Order Code KEN-512	Price/1 TB
Light Duty	680g	-2780K	411.00
Heavy Duty	860g	-2800K	617.00



Plasterer's Hawk

Lightweight scoured aluminium blade to prevent plaster 'slip-off'. Detachable wooden handle with cushioned comfort ring. Designed to reduce discomfort during periods of extended use. Manufactured to the high standards expected by today's trade.



Size (mm)	Weight per 10	Order Code KEN-512	Price/1 TB
300 x 300	7.00kg	-0920K	979.00

Plasterer's Trowel

Aluminium shank single tang banana pattern. Six rivet construction 'cross ground' to prevent drag. For laying on and finishing plaster. Manufactured to the high standards expected by today's trade.



Size	Weight per 10	Order Code KEN-512	Price/1 TB
280mm (11")	4.00kg	-0100K	1602.00



Wooden Skimming Float

Manufactured from selected timber. Ideal for producing a sandy surface finish when rendering plaster or concrete.



Size (mm)	Weight per 10	Order Code KEN-512	Price/1 TB
290 x 100	190g	-0950K	876.00

Adhesive Trowel

High quality moulded and contoured handle. Large base with two coarse pitched edges and two fine pitched edges. Suitable for use with all tile and carpet adhesives.



Size (mm)	Weight per 10	Order Code KEN-512	Price/1 TB
270 x 110	190g	-0400K	308.00

HAND TOOLS

GROUP 512 BRICK TOOLS

SENATOR
QUALITY TOOLING

Builder's Trowel



Ground polished, hardened and tempered high carbon steel alloy blades, tapered to remain rigid right to the tip with high angle handles for improved knuckle clearance and control. Chromed ferrules hold the forged tang firmly.

Broad Heel Brick Trowel

11" heel width. London pattern, a smooth rounded end wooden handle with integral tang.



Overall Length	Type	Order Code	Price/1 TB
280mm (11")	London	SEN-512-0060K	258.00

Pointing Trowel

Ground polished, hardened and tempered high carbon steel alloy blade, high angle handle. Chromed ferrule holds the forged tang firmly. London pattern, a smooth rounded end wooden handle with integral tang.

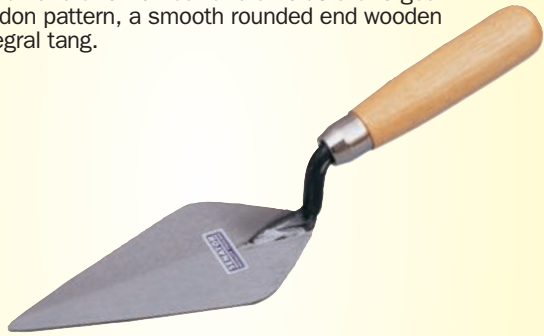

Overall Length	Width (mm)	Order Code	Price/1 TB
150mm (6")	75	SEN-512-0020K	212.00

Gauging Trowel

London pattern, a smooth rounded end wooden handle with integral tang.



Overall Length	Width (mm)	Order Code	Price/1 TB
180mm (7")	90	SEN-512-0040K	308.00

KENNEDY
PROFESSIONAL

Professional Brick Trowel



Manufactured from high carbon tempered and hardened steel with a ground and polished finish, tapered to remain rigid to the tip. Polished and varnished high angle handle, with chromed ferrule, holds the tang in place preventing the blade from twisting.



Overall Length	Width (mm)	Order Code	Price/1 TB
280mm (11")	140	KEN-512-0060K	1029.00

Professional Pointing Trowel

Made from high carbon tempered and hardened steel with a ground and polished finish. Tapered to remain rigid to the tip. Polished and varnished high angle handles for greater balance, control and knuckle clearance, with chromed ferrule. Holds the forged steel tang in place preventing the blade from twisting.



Overall Length	Width (mm)	Order Code	Price/1 TB
150mm (6")	75	KEN-512-0020K	464.00

Gauging Trowel

London pattern, a smooth rounded end wooden handle with integral tang.



Overall Length	Width (mm)	Order Code	Price/1 TB
180mm (7")	90	KEN-512-0040K	567.00

KENNEDY
QUALITY INDUSTRIAL TOOLING

Masonry Saws

Hardened and tempered steel blade with carbide teeth.

Heavy Duty

Suitable for cutting man made building blocks and bricks with 35 tungsten carbide teeth.

Medium Duty

Suitable for cement based building blocks, 17 tungsten carbide tips on alternate teeth.



Heavy Duty

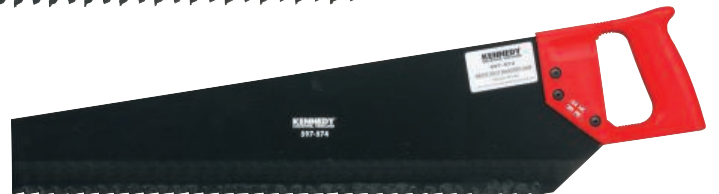

Medium Duty

Type	Blade Length	Teeth per inch	Weight each	Order Code	Price/1 TB
Medium	622mm	17	1.10kg	KEN-597-5720K	2369.00
Heavy	490mm	35	1.20kg	KEN-597-5740K	4685.00

HAND TOOLS

KENNEDY *Double Ended Brick Jointer*
QUALITY INDUSTRIAL TOOLING

Heavy duty steel. Used to produce 1/2" and 5/8" concave joints between bricks.



Overall Length	Order Code	Price/1 TB
580	-0440K	205.00

Brick Jointer

Suitable for half round finishing of the joints between bricks. London pattern smooth wooden handle with integral tang.



Size (mm)	Weight per 10	Order Code	Price/1 TB
150 x 12	1.50kg	-0420K	335.00

Plumb Bobs

Corrosive resistant epoxy coated with brass screw cap. For establishing vertical datum line without the use of a level.



Weight each	Order Code	Price/1 TB
5oz	-2050K	308.00
10oz	-2100K	361.00

Line Pins

Construction quality, hand, chrome plated line pins. Supplied in pairs. Use with Kennedy brick line to create a horizontal line for consistent bricklaying.



Size	Weight per 10	Order Code	Price/pr TB
150mm (6")	140g	-2160K	222.00

Brick Line

Construction quality, use with line pins and plumb bobs.



Size	Weight per 10	Order Code	Price/1 TB
18m (60')	740g	-2180K	57.00

RUTLAND *Flexible Buckets*
CONTRACTORS TOOLS

Extremely versatile and virtually indestructible. It can be used for moving soil, garden waste, rubble and various other jobs around a garden or building site. 460mm diameter.



Size	Weight each	Order Code	Price/1 TB
42ltr	200g	-4880K	361.00



KENNEDY *Builder's Buckets*
QUALITY INDUSTRIAL TOOLING

Capacity: 13.5ltr (3gal.)
Plastic: medium 'V' lip.
Rubatype: Large 'V' lip.
 All rubber.



Type	Weight each	Order Code	Price/1 TB
Plastic	0.55kg	-8030K	475.00
Rubatype	2.10kg	-8130K	499.00



KENNEDY *15ltr Invincible Yellow Builders' Bucket*
QUALITY INDUSTRIAL TOOLING

15ltr (3 gal.) filling scale inside. Five year guarantee.



Capacity	Order Code	Price/1 TB
15ltr	-8300K	368.00



SITESAFE *Builder's Flexible Bucket*
QUALITY INDUSTRIAL TOOLING

Extremely versatile and virtually indestructible. it can be used for mixing plaster or cement, moving rubble and various other jobs around a building site.



Size	Order Code	Price/1 TB
Yellow Buckets		
26ltr	-2980K	308.00
40ltr	-3000K	411.00
75ltr	-3040K	823.00
Blue Buckets		
26ltr	-3080K	411.00
42ltr	-3100K	411.00



PRODUCTS ARE ONLY AVAILABLE VIA YOUR DISTRIBUTOR

GROUP 515 CRIMPING TOOLS

KENNEDY Multi-Purpose Crimping Plier Kit
QUALITY INDUSTRIAL TOOLING

Made from heavy gauge carbon steel heat treated to HRa 65/70. Chemically blackened with cushion grip handles for operator comfort. Kit comes complete with 100 assorted insulated and non-insulated terminals in a neat plastic see through box.

Strip range: 0.75 - 6.
Crimp/cut capacity: 1.5 - 16mm.

**100
PIECES**



Description	Order Code KEN-515	Price/1 TB
Plier only	-5050K	371.00
100 Piece Kit	-5090K	970.00

5-Way Stripping & Crimping Kit

240mm heavy gauge hardened carbon steel wire crimper with anvil action cutters and PVC grip.

Insulation terminals: 1.5mm² (red), 2.5mm² (blue) and 6.0mm² (yellow).

Wire cutters: M2.6, M3.0, M3.5, M4.0 and M5.0mm.

Non insulated terminals: 1.5mm², 2.5mm² 4.0 - 6.0mm².

Wire strippers: 0.75, 1.0, 1.5, 2.5, 4.0 and 6.0mm².

Kit Contents: 40mm 5-Way Crimping Tool.

Blade connectors: red - 2.3 x 10.4mm, blue - 2.8 x 9.0mm.

Push-on spade connectors - male: red - 6.3 x 0.8mm, blue - 6.3 x 0.8mm.

Push-on spade connectors - female: red - 6.3 x 0.8mm, blue - 6.3 x 0.8mm.

Butt connectors: red - 0.5 x 1.5mm², blue - 1.5 x 2.5mm².

Bullet connectors - male: red - 4.0mm², blue - 4.0mm².

Bullet connectors - female: red - 4.0mm, blue - 4.0mm.

Fork connectors: red - 4.0mm, blue - 4.0mm, yellow - 4.0mm.

Ring connectors: red - 4.0mm, blue - 4.0mm, yellow - 6.0mm.

**361
PIECES**



HAND TOOLS

Description	Order Code KEN-515	Price/1 TB
361 Piece Ratchet Crimping Kit	-5530K	1531.00

Heavy Duty Ratchet Crimping Tool Kit

Heavy duty 220mm ratchet crimper with a selection of pre-insulated red, blue and yellow electrical connector terminals, cable ties and insulation tape. Ratchet crimper has laminated steel jaws with strengthened PVC handle grips.

Suitable for crimping insulated terminals as follows: red channel: 0.5 - 1.00mm², blue channel: 1.5 - 2.5mm², yellow channel: 4.0 - 6.0mm².

Supplied in a fitted case with slide locking clips and handle.

Kit contents: Heavy duty ratchet crimper, black insulation tape (19mm x 9m), black cable ties (2.5 x 100mm).

Ring connectors: red - 3.7, 4, 5mm, blue - 3.7, 4, 5, 6mm, yellow - 4, 5mm.

Butt connectors: red - 1.5 x 1.5mm², blue - 1.5 x 2.5mm².

Push-on spade connectors - male: red, blue, yellow - 6.3 x 0.8mm.

Push-on spade connectors - female: red, blue, yellow - 6.3 x 0.8mm.

Push-on spade covered connectors - female: red, blue - 6.3 x 0.8mm.

Push-on piggy back connectors - female: red, blue - 6.3 x 0.8mm.

Bullet connectors - male: red, blue - 4mm.

Bullet connectors - female: red, blue - 4mm.

**552
PIECES**



Description	Order Code KEN-515	Price/1 TB
552 Piece Ratchet Crimping Kit	-5540K	3006.00

Terminals - Rings/Forks

Red ring 4BA, 2BA and 1/4.
 Blue ring 2BA, 1/4 and 5/16.
 Yellow ring 1/4, 5/16 and 3/8.
 Spade blue, red and yellow.

Average quantity:
 300 pieces.



Type	Average Quantity	Weight each	Order Code KEN-515	Price/1 TB
Terminals	300	0.60kg	-5620K	1029.00

Terminals - Spades/Bullets/Butt Connectors

Contents:

Butt connectors:
 red, blue and yellow.

Spade connectors (push-on female):
 6.3mm - red, blue and yellow.

Female bullet connectors:
 4mm - red, and blue.

Male bullet connectors:
 4mm - red and blue.



Type	Average Quantity	Weight each	Order Code KEN-515	Price/1 TB
Terminals	240	0.40kg	-5610K	1133.00

KENNEDY *Standard Industrial*
QUALITY INDUSTRIAL TOOLING **Terminals**

Durable low cost copper or brass connectors. Manufactured as single piece connectors. Electro tinned to protect from corrosion. Insulated with flared entry, colour coded vinyl sleeves. All disconnect terminals supplied with anti-vibration copper sleeve.

Push-on Female and Male Tab Connector Terminals
Pack quantity: 100.



Type	Colour	Tab Size (mm)	Order Code KEN-515	Price/Pk TB
Push-on	Red	6.3 x 0.8	-3000K	262.00
Push-on	Blue	6.3 x 0.8	-3010K	292.00
Push-on	Yellow	6.3 x 0.8	-3020K	445.00
Tab	Red	6.3 x 0.8	-3700K	262.00
Tab	Blue	6.3 x 0.8	-3710K	262.00
Tab	Yellow	6.3 x 0.8	-3720K	416.00

Push-on Fully Insulated Female Connector Terminals
Pack quantity: 100.



Type (Female)	Colour	Tab Size (mm)	Order Code KEN-515	Price/Pk TB
Push-on	Red	6.3	-1520K	585.00
Push-on	Blue	6.3	-1500K	691.00
Push-on	Yellow	6.3	-1540K	821.00

Push-on Piggy Back Terminals
Pack quantity: 100.

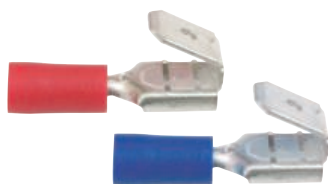

Type (Female)	Colour	Tab Size (mm)	Order Code KEN-515	Price/Pk TB
Push-on	Red	6.3	-3730K	482.00
Push-on	Blue	6.3	-3740K	603.00

Heat Shrink Tubing Kits

Suitable for connecting, end handling, electric wire insulating and harnessing, corrosion proofing metal rods and tubes, antenna protection. Made from halogen-free environmentally friendly polyolefin which is flame retardant and RoHS compliant. It's operating temperature is from 55°C to 125°C and shrinking starts at 70°C and becomes totally shrunk at 110°C. It's shrink ratio is 2:1 and has a maximum electrical rating of 600V. Assorted colours. For use with heat guns and gas torches.



-6800K

-6900K



-6910K

Number of Pieces	Tube Dia. (mm)	Order Code KEN-515	Price/Pk TB
32	4.8 (16), 6.4 (12), 9.5 (4)	-6800K	514.00
171	2 - 18 (Assorted)	-6900K	603.00
181	2 - 9 (Assorted)	-6910K	1036.00

Blade Connector Terminals
Pack quantity: 100.



Type	Colour	Size (mm) Dia. x L	Order Code KEN-515	Price/Pk TB
Blade	Red	2.3 x 10.4	-2000K	202.00
		1.9 x 18.4	-2010K	218.00
Blade	Blue	2.8 x 9.0	-2050K	199.00
		2.3 x 18.4	-2060K	244.00
Blade	Yellow	2.8 x 10.0	-2100K	422.00

Fork and Ring Connector Terminals
Pack quantity: 100.



Type	Colour	Tab Size (mm)	Order Code KEN-515	Price/Pk TB
Fork	Red	3.2	-2200K	177.00
		3.5	-2210K	177.00
		4.0	-2220K	177.00
		5.0	-2230K	177.00
		6.0	-2240K	243.00
Fork	Blue	3.2	-2260K	193.00
		3.5	-2270K	193.00
		4.0	-2280K	193.00
		5.0	-2290K	193.00
		6.0	-2300K	256.00
Fork	Yellow	3.0	-2320K	292.00
		4.0	-2330K	292.00
		5.0	-2340K	292.00
Ring	Red	6.0	-2350K	377.00
		3.0	-2400K	160.00
		3.7	-2410K	160.00
		4.0	-2420K	177.00
		5.0	-2430K	177.00
		6.0	-2440K	243.00
		8.0	-2450K	243.00
		10.0	-2460K	340.00
		3.0	-2500K	193.00
		3.7	-2510K	193.00
Ring	Blue	4.0	-2520K	193.00
		5.0	-2530K	193.00
		6.0	-2540K	256.00
		8.0	-2550K	266.00
		10.0	-2560K	340.00
		12.0	-2570K	603.00
		3.0	-2600K	292.00
		4.0	-2620K	292.00
		5.0	-2630K	361.00
		Ring	Yellow	6.0
8.0	-2650K			448.00
10.0	-2660K			448.00
12.0	-2670K			618.00

Butt Connector Terminals
Pack quantity: 100.



Type	Colour	Pack Quantity	Order Code KEN-515	Price/Pk TB
Butt	Red	100	-2900K	262.00
Butt	Blue	100	-2910K	262.00
Butt	Yellow	100	-2920K	416.00

Female Socket and Male Bullet Connector Terminals
Pack quantity: 100.



Type	Colour	Bullet Dia. (mm)	Order Code KEN-515	Price/Pk TB
Socket	Red	4.0	-3100K	353.00
Socket	Blue	4.0	-3110K	370.00
		5.0	-3120K	370.00
Socket	Yellow	5.0	-3130K	535.00
Bullet	Red	4.0	-3500K	271.00
Bullet	Blue	4.0	-3510K	292.00
		5.0	-3520K	292.00
Bullet	Yellow	5.0	-3530K	504.00

HAND TOOLS

GROUP 515 CRIMPING TOOLS

KENNEDY PROFESSIONAL Crimping Tools



Adaptable crimping tool with 4 easy-change dies to meet your crimping needs. The design features a ratchet handle to enable the application of consistent pressure, as well as a quick release lever, tension adjustment wheel, locking screw and soft grip handles. Heat treated steel with a zinc phosphate surface finish.

NEW

KRC04 4 Piece Ratchet Crimping Tool Set
Dies supplied:

Insulated Terminal:
0.5-1.0mm² - 4.0-6.0mm²

Non-insulated Terminal:
1.5mm² - 10mm²

8 Position 8 Connector:
8P8C/RJ45 Plugs

RG Type Coaxial Connector: RG 58, 59, 62 and 6, 6.48mm - 8.23mm.

Ratchet handle for consistent pressure

'Quick Release' feature

Finished with heat treatment and zinc phosphate surface treatment

Soft grip handles



KRC04

This set contains Die types A, B, E and G3. See below and left for full details.

Product Number	Size	Order Code KEN-515	Price/1 TB
KRC04	4	-5710K	5609.00

HAND TOOLS

Die Type A



Insulated Terminal
AWG 22-18/16-14/12-10/
0.5-1.0/1.5-2.5/4.0-6.0mm²

Used for:
Auto
Machine Wiring
Technician
Electrician

Die Type B

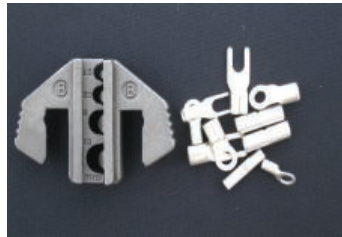

Non-Insulated Terminal
AWG 20-18/16-14/12-10/8.0
1.5/2.5/6.0/10mm²

Used for:
Auto
Machine Wiring
Technician
Electrician

Die Type C

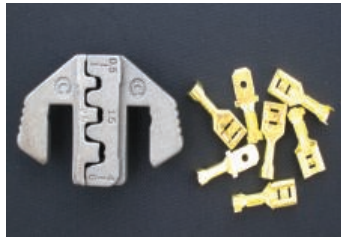

Open Barrel Terminal
AWG 20-18/16-14/12-10
0.5/1.0/1.5-2.5/4.0-6.0mm²

Used for:
Auto
Computer
Radio
Machine Wiring

Die Type D



Cord End Terminal (Small AWG)
AWG 22/20/18/16/14/12
0.5/0.75/1.0/1.5/2.5/4.0mm²

Used for:
Auto
Machine Wiring
Electrical Engineer

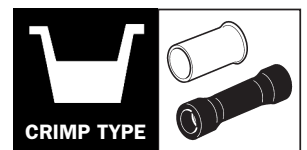
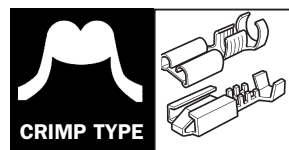
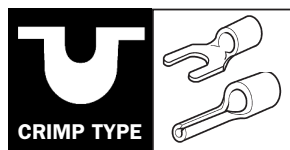
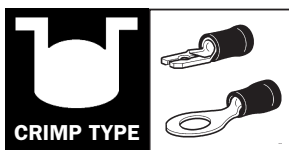

Type	Order Code KEN-515	Price/1 TB
A	-5100K	617.00

Type	Order Code KEN-515	Price/1 TB
B	-5110K	617.00

Type	Order Code KEN-515	Price/1 TB
C	-5120K	617.00

Type	Order Code KEN-515	Price/1 TB
D	-5130K	617.00



KENNEDY PROFESSIONAL *Crimping Tools*

Adaptable crimping tool with 4 easy-change dies to meet your crimping needs. The design features a ratchet handle to enable the application of consistent pressure, as well as a quick release lever, tension adjustment wheel, locking screw and soft grip handles. Heat treated steel with a zinc phosphate surface finish.

NEW

KRC07 7 Piece Ratchet Crimping Tool Set

Dies supplied:

Insulated Terminal:
0.5- 6.0mm²

Non-insulated Terminal:1.5mm² - 10mm²

Open Barrel Terminal:
0.5 - 6.0mm²

Cord End Terminal (Small AWG):
0.5mm² - 4.0mm²

RG Type Coaxial Cable Connector:
RG 58, 59, 62 and 6, 6.48mm - 8.23mm

Cord End Terminal (Large AWG):
0.5mm² - 16.0mm²

Open Barrel Terminal 7 D-SUB, V3.5:2.5mm² - 8.0-10.0mm²

Ratchet handle for consistent pressure

'Quick Release' feature

Finished with heat treatment and zinc phosphate surface treatment

Soft grip handles



KRC07

This set contains Die types A, B, C, D, E, F, and H. See below and right for full details.

Product Number	Size	Order Code KEN-515	Price/1 TB
KRC07	7	-5740K	7262.00

Die Type E



RG Type Coaxial Cable Connectors
.255"/.213"/.100"/.324"
6.48/5.41/2.54/1.72/8.23mm
RG 58, 59, 62.6.

Used for:
CCTV DTV radio DTS, GRS, TM control systems.
Image transmission speed.
Tester audio line.
Car digital TV receiver.
Satellite TV.
Car navigation.
Automotive GPS devices.
Audio visual equipment.

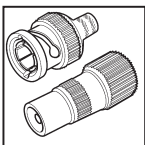

Die Type F



Cord End Terminal (Large AWG)
AWG 10/8.0/6.0
6.0/10/16mm².

Used for:
Auto.
Machine Wiring.
Electrician Euro Market.

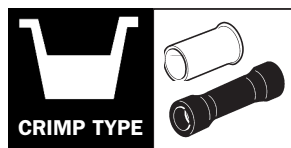

Die Type H



Open Barrel Terminal 7 & D-Sub V3.5
AWG 14-22/16-14/12-10
2.5/0.5/8.0-10.0mm².

Used for:
Auto.
Computer.
Radio.
Machine Wiring.

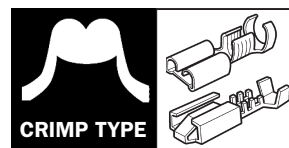

Die Type G3



8P8C Connector
8P8C/R145 Plugs.

Used for:
Computer.
ADSL.

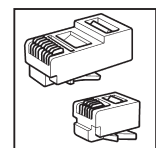

Type	Order Code KEN-515	Price/1 TB
E	-5140K	617.00

Type	Order Code KEN-515	Price/1 TB
F	-5150K	617.00

Type	Order Code KEN-515	Price/1 TB
H	-5160K	617.00

Type	Order Code KEN-515	Price/1 TB
G3	-5170K	720.00

PRODUCTS ARE ONLY AVAILABLE VIA YOUR DISTRIBUTOR

HAND TOOLS

KENNEDY Ferrule Crimp Tool
QUALITY INDUSTRIAL TOOLING

Ferrule crimp tool with full cycle ratcheting crimp frame and adjustable crimp pressure. Carbon steel jaws with a chemically blacked finish and PVC handles.

Model TCF 004

Capacity: 0.5, 0.75, 1.0, 1.5, 2.5 and 4mm². AWG 20, 18, 17, 16, 13 and 11.

Model TCF 016

Capacity: 6, 10 and 16mm². AWG 10, 8 and 6.

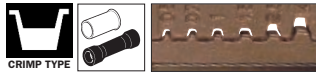

Model Number	Order Code KEN-515	Price/1 TB
TCF004	-5200K	1804.00
TCF016	-5210K	1914.00
Replacement Jaws (TCF004)	-6200K	1092.00
Replacement Jaws (TCF016)	-6300K	1092.00

Uninsulated Terminal Crimp Tool

Model TCU 006

Uninsulated terminal crimp tool with full cycle ratcheting crimp frame and adjustable crimp pressure. Carbon steel jaws with a chemically blacked finish and PVC handles.

Tab width: 6.3mm.

Capacity: 0.5 - 1.0, 1.0 - 2.5 and 4.0 - 6.0mm².

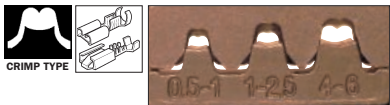

Model Number	Order Code KEN-515	Price/1 TB
TCU006	-5400K	2163.00
Replacement Jaws	-6400K	1092.00

Crimp Tool Kit

Model TCK 005

Crimp tool kit with full cycle ratcheting crimp and adjustable crimp pressure frame. Five pairs of interchangeable hardened and tempered carbon steel jaws with a chemically blacked finish for terminals, connectors, ferrules and end sleeves. Supplied in a robust plastic carry case.



Product Number	Order Code KEN-515	Price/1 TB
TCK 005	-5500K	5655.00

Replacement Jaws To suit Kennedy ratcheting frame crimping tools.

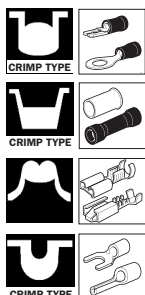

Crimp Type	Order Code KEN-515	Price/1 TB
Ferrule Terminals 0.5mm ² - 4mm ²	-6200K	1092.00
Insulated Terminals 0.5mm ² - 6.0mm ²	-6220K	1092.00
Ferrule Terminals 6mm ² - 16mm ²	-6300K	1092.00
Uninsulated Terminals 0.5mm ² - 6.0mm ²	-6400K	1092.00
Uninsulated Terminals 1.5mm ² - 10.0mm ²	-6500K	1060.00

Insulated Terminal Crimp Tool

Model TCI 006

Insulated terminal crimp tool, with full cycle ratcheting crimp frame and colour coded jaws, with adjustable and preset crimp pressure for accurate crimping. Carbon steel, hardened and tempered jaws with a chemically blacked finish and PVC handles.

Capacity:

Red: 0.5 - 1.5mm², AWG 20 - 16.
Blue: 2.5mm², AWG 14.
Yellow: 4.0 - 6.0mm², AWG 12 - 10.

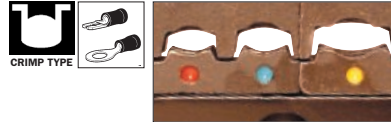

Model Number	Order Code KEN-515	Price/1 TB
TCI006	-5220K	2488.00
Replacement Jaws	-6220K	1092.00

Uninsulated Terminal Crimp Tool

Model TCU 016

Uninsulated terminal crimp tool with full cycle ratcheting crimp frame and adjustable crimp pressure. Carbon steel jaws with a chemically blacked finish and PVC handles.

Capacity: DIN 1 - 2, 6, 10 and 16mm². AWG 14, 10, 8 and 6.

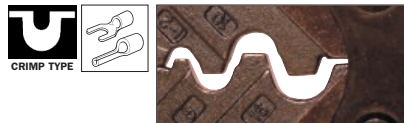

Model Number	Order Code KEN-515	Price/1 TB
TCU016	-5420K	3011.00
Replacement Jaws	-6420K	1422.00

Coaxial Crimp Tool

Model TCC 008

Coaxial crimp tool with full cycle ratcheting crimp frame and adjustable crimp pressure. Carbon steel jaws with a chemically blacked finish and PVC handles.

Suitable for RG cable: 6, 58, 59 and 62. Hexagonal crimp of 1.72, 2.5, 5.4, 6.48 and 8.22mm.



Model Number	Order Code KEN-515	Price/1 TB
TCC008	-5340K	2059.00
Replacement Jaws	-6340K	1092.00

Modular Plug Crimp Tool

Model MCT 008

Modular plug crimping tool complete with wire cutting and stripping facilities. Manufactured from hardened and tempered carbon steel with chemically blacked finished and tempered jaws with PVC handles.

Capacity: 8P8C/RJ-45, 6P/RJ-12, RJ-11 and 6P2C.



Model Number	Order Code KEN-515	Price/1 TB
TMCT008	-5460K	1906.00

Heavy Duty Crimp Tool

Model TCU 095

Heavy duty crimp tool for uninsulated terminals. Tool steel jaws and manufactured from ductile iron.

Capacity: cable lugs: 10mm² - 95mm². Aluminium AWG to 4/0. Copper 8WG to 250 MCM.

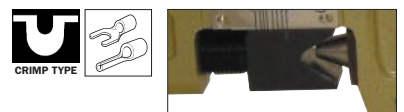

Model Number	Order Code KEN-515	Price/1 TB
TCU095	-5440K	7725.00
Replacement Jaws	-6440K	2266.00

CABLE TIES & MAINS TESTERS

KENNEDY Cable Tie Gun
QUALITY INDUSTRIAL TOOLING



Steel jaws grip the cable with trigger action for rapid tightening, tensioning and trimming, ideal for production environments.

Capacity:
2.4 to 4.8mm width.



Capacity (mm)	Order Code	Price/1 TB
2.4 - 4.8	KEN-516 -8400K	1133.00

Mains Testers

With heavy duty one-piece moulded insulation sheaths covering both blade and transparent plastic handle for extra protection and safety. Will detect 'live' electricity supply. Suitable for AC to 125 - 250V. 3mm wide tip. Conforms to **DIN VDE 0680 part 6:1977-04.**



Blade Length	Cap Type	Weight per 12	Order Code	Price/1 TB
150mm	Plastic	210g	KEN-515 -0500K	111.00
190mm	Plastic	400g	-0550K	121.00

EDISON Cable Ties



Suitable for securing or retaining cables and objects of various shapes and sizes. Tensile strengths of 8 to 22kg. Heat resistant from 40°C to 85°C. Supplied in pack of 100.



1001 USES IN THE WORKSHOP OFFICE GARDEN and HOME

NEW

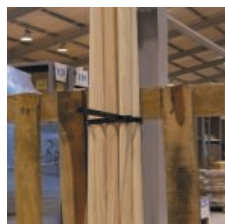
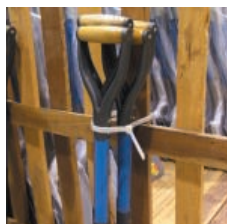
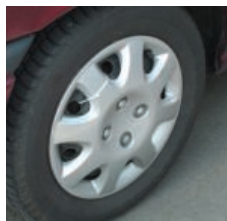

Size (mm)	Order Code EDI-515		Price/100 TB
	Black	Natural	
2.5 x 100	-0000K	-1000K	48.00
2.5 x 160	-0010K	-1010K	69.00
2.5 x 200	-0020K	-1020K	99.00
3.6 x 140	-0100K	-1100K	135.00
3.6 x 200	-0110K	-1110K	135.00
3.6 x 300	-0120K	-1120K	185.00
3.6 x 370	-0130K	-1130K	235.00
4.8 x 120	-0200K	-1200K	125.00
4.8 x 200	-0210K	-1210K	165.00
4.8 x 300	-0220K	-1220K	235.00
4.8 x 370	-0230K	-1230K	350.00
4.8 x 430	-0240K	-1240K	375.00
7.6 x 200	-0300K	-1300K	350.00
7.6 x 300	-0310K	-1310K	450.00
7.6 x 370	-0320K	-1320K	550.00
7.6 x 450	-0330K	-1330K	625.00
9.0 x 530	-0400K	-1400K	1100.00
9.0 x 780	-0410K	-1410K	1300.00
12.7 x 580	-0500K	-1500K	1500.00

Assorted Cable Tie Sets

Contains 100 of each size:
2.5 x 100mm and 160mm,
3.5 x 200mm and 300mm,
4.8 x 200mm and 300mm.



600 PIECES

Colour	Weight	Order Code	Price/1 TB
Black	645g	EDI-515 -3000K	1167.00
Natural	645g	-3010K	1167.00

Cable Tie Sets

Contents comprise of one width x two lengths:
2.5mm - 100mm and 160mm,
3.5mm - 200mm and 300mm,
4.8mm - 200mm and 300mm.

Width	Colour	Pk Qty	Order Code	Price/1 TB
2.5mm	Black	300	EDI-515 -3040K	139.00
2.5mm	Natural	300	-3050K	139.00
3.5mm	Black	400	-3060K	484.00
3.5mm	Natural	400	-3070K	484.00
4.8mm	Black	500	-3080K	1029.00
4.8mm	Natural	500	-3090K	1029.00

HAND TOOLS

KENNEDY Magnetic Cable Guider
QUALITY INDUSTRIAL TOOLING



An innovative tool for inserting cables through brick walls, cavity walls, studwork etc. Tested by major utilities - saves hours of engineers time. Includes three adaptors for 3.7 to 5.9mm cable diameters. Drill bit not included.



NOT FOR USE WITH LIVE CABLES!

Type	Order Code	Price/1 TB
Cable Guider	KEN-516 -9600K	979.00
Caps (Pk 6)	-9620K	464.00

PRODUCTS ARE ONLY AVAILABLE VIA YOUR DISTRIBUTOR

GROUP 516 CABLE & WIRE STRIPPING TOOLS

KENNEDY *No.500 Cable Stripper/ Screwdriver/Volt Tester*
QUALITY INDUSTRIAL TOOLING

The newly developed Multi-Stripper PLUS, screwdriver, voltage tester, stripper for conductors, round and coaxial cables and cutter in only one tool. **Screwdriver:** two double ended bits: No.1PZ and 8855; x 3.5 slotted No.2PZ and 8855: x 4.0 slotted bit storage inside ergonomic dual material handle. **Voltage tester:** 110 - 250V. **Round cable stripper:** capacity 8 - 13mm dia (eg NYM 3x 1.5mm - 5x 2.5mm). **Built-in side cutter:** for PVC-isolated round cables max. 9mm dia. **Coax stripper:** two or three-level stripping of all common coaxial cables of 4.8 - 7.5mm dia. **Wire stripper:** for all common stranded and solid conductors 0.5mm (20AWG) to 6.0mm (10AWG).

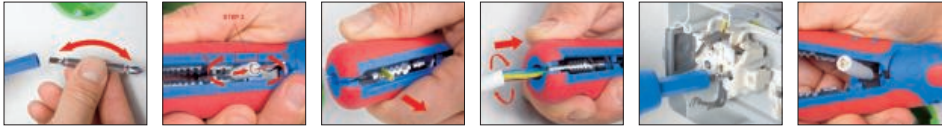

Capacity (mm)	Order Code	Price/1 TB
8.0 - 13.0	KEN-516 -8340K	2472.00

Multi-Stripper PLUS



Cable stripper for round and continental type cables of 8 - 13mm dia (e.g. NYM 3x 1.5mm, up to 5x 2.5mm). Flush stripping even in hard-to-reach areas, e.g. ceiling and wall areas, junction and distribution boxes, switch cabinets, etc. The ergonomic tool design provides a sure grip and safe handling. Needs no adjustment of the cutting depth.



Capacity (mm)	Order Code	Price/1 TB
0.5 - 6.0	KEN-516 -8300K	909.00

HAND TOOLS

Cable Strippers

Durable plastic bodies with hardened and ground sharpened steel blades with precise depth of cut adjustment. Spring loaded safety cover, covers the blade when not in use. For standard and solid conductors. Hardened steel blades.

CS16

For stripping of all common round cables of 4 - 28mm. Wire stripper adjusts automatically to diameter of wire to allow quick and accurate stripping. Stripping blades are made from hardened steel.

Overall length: 125mm.



CS27

For stripping of all common round cables of 4 - 28mm. Wire stripper adjusts automatically to diameter of wire to allow quick and accurate stripping. Stripping blades are made from hardened steel.

Overall length: 130mm.



CS28

Complete with hook knife for splitting flat and ribbon cables along its length.

Overall length: 170mm.



Product Number	Capacity (mm ²)	Weight each	Order Code	Price/1 TB
CS16	4.0 - 16.0		-7900K	712.00
CS27	8.0 - 27.0		-7910K	738.00
CS28	4.0 - 28.0		-7920K	761.00
Spares to suit CS16, CS27 & CS28		125g	-7950K	165.00

Cable Stripping Knife

Steel blade and cushioned handle, used for stripping cable and wire.

Overall length: 150mm.



Length	Order Code	Price/1 TB
150mm	KEN-516 -7500K	438.00

Wire Stripper & Cutter

Unique self-adjusting cutting action for rapid repeatable wire stripping. Hardened and tempered ground steel blades housed in durable plastic bodies contoured to fit comfortably into the hand for extended periods of use encountered in electrical assembly industries.

Mini-Duo Wire Stripper & Cutter

Fully insulated wire stripper for all common stranded and solid conductors of 0.5 - 6.0mm². Adjusts automatically to diameter of wire. Blades are made from hardened steel.

Overall length: 155mm.



Capacity (mm ²)	Order Code	Price/1 TB
0.5 - 6.0	KEN-516 -7980K	1526.00

Super Wire Stripper & Cutter

Fully insulated for all stranded and solid conductors from 0.2 to 6mm². Automatically adjusts to the diameter of wire. Reinforced polyamide construction.

Overall length: 195mm.



Capacity (mm ²)	Order Code	Price/1 TB
0.2 - 6.0	KEN-516 -7970K	1639.00

Co-axial Cable Cutter

Two preset pairs of blades, one for outer sheathing, one for dielectric. For cable diameter range of 4.8 - 7.5mm². Also strips flexible cables of 3 x 0.75mm², 10mm² and 16mm².

Overall length: 110mm.

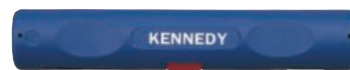

Capacity (mm ²)	Order Code	Price/1 TB
4.8 - 7.5	KEN-516 -7960K	1837.00

KENNEDY Cable Stripper & Ripper
QUALITY INDUSTRIAL TOOLING

MK02

For stripping of outer insulation from cables. Spring loaded gripping arm, blade has adjustable cutting depth of up to 3mm. Blade can be turned through 90° by pushing the side button, to cut along the length of cable. Also features a spring loaded ripping blade for insulation removal.

Overall length: 138mm.



Capacity (mm ²)	Order Code KEN-516	Price/1 TB
4.5 - 28.0	-8040K	2570.00
5 Spare Blades	-8030K	2207.00

Wire Stripper, Cutter & Crimper

Duo Crimp

Combined stripping and crimping tool. Stripping tool adjusts automatically to the diameter of the wire.

Wire diameter range: 0.5 - 6.0mm². Two crimping ranges are available 0.5 - 1.5mm² and 2.5 - 6.0mm².

Complete with side wire cutter.

Overall length: 155mm.



Capacity (mm ²)	Weight each	Order Code KEN-516	Price/1 TB
0.5 - 6.0	150g	-8520K	3245.00

Electrician's Shears

For use on soft cable up to 22mm² diameter, can also be used for stripping, cutting insulation materials, electrical tape and cable ties. Stainless steel blades with hardened edge with vanadium and molybdenum for long lasting edge. HRC58-60 with one cutting edge serrated to reduce slipping and notched blade for tough and large diameter cuts. Tough, lightweight nylon handles. Supplied with handy clip-on belt pouch.

Cutting length: 45mm (1¾").



Length (mm)	Weight each	Order Code KEN-516	Price/1 TB
140	150g	-6400K	876.00

Powerstrip Wire Stripper

Self adjusting. Wire is gripped and stripped in a single action. Also features a wire cutter to allow for trimming. Adjustable slide and lock wire stop for fast accurate setting of strip length.



Overall length: 175mm.

Capacity (mm ²)	Order Code KEN-516	Price/1 TB
1.25 - 6.0	-8065K	3142.00

SENATOR Automatic Wire Stripper
QUALITY TOOLING



For stripping single core wire up to 6mm diameter. Also with bypass action cutting blades for wire up to 6mm diameter.



Capacity (mm)	Order Code SEN-516	Price/1 TB
6.0	-8240K	621.00

KENNEDY Fibre Optic Cutter
QUALITY INDUSTRIAL TOOLING



FOC145

Designed for cutting fibre optics, KEVLAR materials, plastic canvas, upholstery, headlines, cloth, fabric, string and many more. Lightweight and easy to use for both right and left handed users. Easy reach thumb lock. Long lasting precision ground hardened high carbon alloy steel with molybdenum and vanadium blades. Serrated blade reduces slippage.

Overall length: 145mm (5").

Cutting length: 32mm (1").



Overall Length	Weight each	Order Code KEN-533	Price/1 TB
145mm	82g	-3570K	821.00

Fibre Optic Shears - with Serrated Blade

FOC160

Designed for cutting fibre optics, KEVLAR materials, plastic canvas, upholstery, headlines, cloth, fabric, string and many more. Lightweight and easy to use for both right and left handed users. Long lasting precision ground hardened high carbon alloy steel with Molybdenum and Vanadium blades. Serrated blade reduces slippage. Adjustable pivot point adjusts the tension between the blades. Extended tang for durability.

Overall length: 160mm

Cutting length: 42mm.

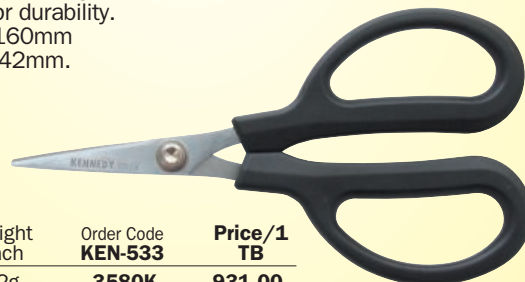

Overall Length	Weight each	Order Code KEN-533	Price/1 TB
160mm	82g	-3580K	931.00

HAND TOOLS

Butane soldering irons can be used anywhere, any time, without having to plug into the wall. They don't have power cables making them ideally suitable for fine work. The run time for the irons varies from 30 to 90 minutes, depending on model and heat setting, but refilling them with butane gas only takes about 20 seconds. They offer more flexibility than traditional soldering irons as you can change the size of the soldering tips, put hot blow air tips for heat-shrink work, put hot knife tips on for cutting plastic, and flame tips for brazing. The temperature can be controlled very easily for each application (580°C to 1,300°C) with the temperature adjustment dial. Butane soldering irons don't use an open flame, unless using the flame tip. There are small catalytic combustion screens built into the other tips, which heat up and glow so that soldering iron won't flame out.

KENNEDY *Butane Soldering Tool*
QUALITY INDUSTRIAL TOOLING

Flint type ignition which is built into the cap. Uses standard butane lighter fuel and is simple to refill. Fully adjustable tip temperature control with a safety fuel cut-off when cap is replaced. Textured anti-slip barrel. Supplied with pointed soldering tip. Can be used with double flat, hot air, flame and hot knife, can also be used as a blow torch. Supplied without fuel.

Power rating:	50W
Soldering temperature	375°C
Run time	60 minutes
Overall length with cap:	195mm
Overall length with soldering tip:	180mm.

Product Number	Weight each	Order Code	Price/1 TB
BS050	100g	KEN-516 -9000K	1165.00

Butane Soldering Iron Tips

Interchangeable tips for use with Kennedy butane soldering tools.



To Suit BS050 Soldering Iron

Type	Size (mm)	Order Code	Price/1 TB
Double Flat Tip	2.4	-9050K	205.00
	4.8	-9040K	205.00
Fine Tip		-9060K	205.00
Hot Knife Tip		-9070K	205.00

Butane Soldering Tool Kit

Supplied in a robust plastic case with inlay.

Contents:

BS050 Butane soldering iron, tip cleaning sponge, stand, four interchangeable tips: 4.8mm and 3.0mm, double flat, hot knife.



Type	Weight each	Order Code	Price/1 TB
6 Piece Soldering Kit		KEN-516 -9020K	2059.00

SENATOR *Butane Micro Soldering Tool*
QUALITY TOOLING

Cordless and refillable. Uses standard butane lighter fuel. 120W rating. Working temperature range up to 1,300°C. Lightweight, windproof flame, ideal for outdoors. Easily removed nozzle for cleaning or replacement. Can be used for shrinking heat seal plastic tubing. Light duty soldering. Craft projects. Thawing frozen locks. Includes one refillable fuel cartridge.



Weight each	Order Code	Price/1 TB
105g	SEN-516 -2000K	644.00

KENNEDY *Butane Soldering Tool*
QUALITY INDUSTRIAL TOOLING

PIEZO self ignition. Uses standard butane lighter fuel and is simple to refill. Fully adjustable tip temperature control with a safety fuel cut-off when cap is replaced. Textured anti-slip barrel with built in stand for anti roll. Supplied with pointed soldering tip. Can be used with double flat, hot air, flame and hot knife, can also be used as a blow torch. Supplied without fuel.



Power rating:	50W
Soldering temperature	375°C
Run time	60 minutes
Overall length with cap:	195mm
Overall length with soldering tip:	180mm.

Product Number	Weight each	Order Code	Price/1 TB
BS075	100g	KEN-516 -9100K	3089.00

Butane Soldering Iron Tips

Interchangeable tips for use with Kennedy butane soldering tools.

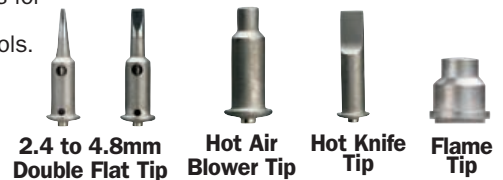

To Suit BS075 Soldering Iron

Type	Size (mm)	Order Code	Price/1 TB
Double Flat Tip	2.4	-9140K	428.00
	3.2	-9150K	428.00
	4.8	-9160K	428.00
Hot Air Tip		-9170K	428.00
Flame Tip		-9180K	428.00
Hot Knife Tip		-9190K	428.00

Butane Soldering Tool Kit

Supplied in a robust plastic case.

Contents: BS075 butane soldering iron, tip cleaning sponge, eight interchangeable tips: 2.4mm single flat, 1, 2.4, 3.2, 4.8mm double flat, hot air blower, hot knife and hot air deflector.



Product Number	Weight each	Order Code	Price/1 TB
75BW - 7 Piece Soldering Kit	280g	KEN-516 -9120K	4893.00

HAND TOOLS

SENATOR QUALITY TOOLING Butane Soldering Torch

Flint type ignition which is built into the cap. Uses standard butane lighter fuel and is simple to refill. Fully adjustable tip temperature control. Supplied with pointed soldering tip and a stand with sponge. Supplied without fuel.



Power rating:	30W - 80W
Soldering temperature	1300°C
Run time	45 minutes
Overall length with cap:	235mm
Overall length with soldering tip:	230mm.

Type	Weight each	Order Code SEN-516	Price/1 TB
Soldering Torch	105g	-2020K	984.00

4-In-1 Butane Torch Kit

This excellent soldering kit represents exceptional value for money and contains: Butane soldering tool complete with 2.4mm soldering tip, hot knife tip, hot air tip and flame tip. Protective cap with pocket clip. Stand and sponge.

Applications:

soldering circuit boards, craft projects, thawing frozen locks, shrinking heat seal plastic tubing and cauterising rope.

The needle and 2.4mm soldering tip must be used in conjunction with the interchangeable tip holder.



Type	Weight each	Order Code SEN-516	Price/1 TB
4-In-1 Soldering Kit	467g	-2040K	1708.00

Spares for 4-In-1 Torch Kit

Product Number	Order Code SEN-516	Price/1 TB
Flame Tip	-2060K	102.00
Needle Soldering Tip	-2080K	102.00
2.4mm Soldering Tip	-2100K	129.00
Hot Blower Tip	-2120K	181.00
Hot Knife Tip	-2140K	181.00
Interchangeable Tip Holder	-2200K	205.00

KENNEDY QUALITY INDUSTRIAL TOOLING Butane Soldering Tool

Piezo self ignition. Uses standard butane lighter fuel and is simple to refill. Fully adjustable tip temperature control with a safety fuel cut-off when cap is replaced. Textured anti-slip barrel with built-in stand for anti roll. Supplied with pointed soldering tip. Can be used with single flat, double flat, hot air, hot air deflector and hot knife, can also be used as a blow torch. Supplied without fuel.



Power rating:	25W - 125W
Soldering temperature	580-1300°C
Run time	60 minutes
Overall length with cap:	235mm
Overall length with soldering tip:	230mm.

Product Number	Weight each	Order Code KEN-516	Price/1 TB
BS125	145g	-9300K	4398.00

Butane Soldering Iron Tips

Interchangeable tips for use with Kennedy butane soldering tools.

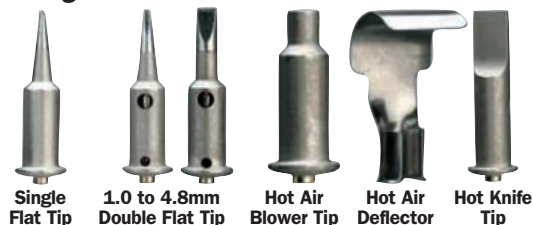

To Suit BS125 Soldering Iron

Type	Size (mm)	Order Code KEN-516	Price/1 TB
Single Flat Tip	2.4	-9340K	514.00
	1.0	-9350K	514.00
	2.4	-9360K	514.00
Double Flat Tip	3.2	-9370K	514.00
	4.8	-9380K	514.00
Hot Air Blower Tip		-9390K	514.00
Hot Air Deflector		-9400K	514.00
Hot Knife Tip		-9410K	514.00

Butane Soldering Tool Kit

BSK125

Butane soldering iron complete with 5 tip attachments, cleaning sponge and safety stand.

Kit contents: 1x butane soldering iron. 5x tip attachments: 2.4mm and 4.8mm double flat, hot knife, hot air blower and hot air deflector. 1x cleaning sponge, 1x safety stand.



Number of Pieces	Weight each	Order Code KEN-516	Price/1 TB
8	460g	-9320K	6603.00

GROUP 516 SOLDERING TOOLS

KENNEDY Soldering Irons
QUALITY INDUSTRIAL TOOLING

Thermo-plastic handles, designed for comfort and a firm safe grip. The mains lead is held by a cable clamping screw which eliminates the strain on electrical connections. All supplied complete with a double flat nickel plated tip and 3A 3-pin plug with 1.5m power lead as standard. Manufactured to **BS 3456**. All 230V.

15W Fine Duty For light duty electrical repairs and fine electronics work.



25W General Duty An all-purpose soldering iron for general electrical repairs in the workshop.



40W Medium Duty Medium duty soldering iron for most general soldering where a little more power is required.



75W Heavy Duty Heavy duty soldering iron for metal repairs such as battery connections and other small metal joining tasks.

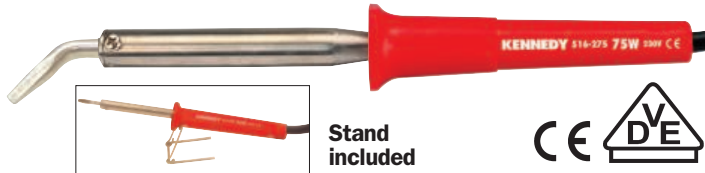

Power Rating	Tip Size (mm)	Duty	Overall Length	Weight each	Order Code KEN-516	Price/1 TB
15W	3.0 Straight	Fine	216mm	270g	-2150K	1384.00
25W	3.0 Straight	General	216mm	270g	-2250K	1508.00
40W	3.0 Offset	Medium	235mm	285g	-2400K	1484.00
75W	6.0 Offset	Heavy	275mm	330g	-2750K	1787.00

Replacement Tips - Double Flat

Tip Style	Tip Size	To Suit Iron	Weight per 10	Order Code SPR-567	Price/1 TB
Flat	3.0mm	15W,25W	-	-3210K	205.00
Flat	3.0mm	40W	-	-3220K	205.00
Flat	6.0mm	75W	460g	-3230K	232.00
45° Offset	6.0mm	75W	460g	-3270K	232.00
45° Offset	6.0mm	40W	-	-3260K	232.00

Multi Angle Vice

Aluminium vice with a two position lockable ball joint, cast steel clamp and swivel mechanism. Horizontal/vertical grooved jaw is designed to hold irregular shaped objects. Removable jaw rubber covers for protecting delicate components. Will clamp to surfaces of 5 to 50mm thickness.

Jaw width: 74mm.

Upright: Rotates through 360° and the vice can swivel between 45° and 135°.

Right angles:

Vice can be rotated through 360°.



Jaw Capacity	Weight each	Order Code KEN-516	Price/1 TB
60mm	930g	-2000K	1422.00



SENATOR Soldering Irons
QUALITY TOOLING

Suitable for workshop and general electrical repair work. Thermo-plastic handles are designed for comfort and a firm safe grip. The mains cable is held by a cable clamping screw which eliminates the strain on the electrical connections. Supplied with a double flat nickel plated tip, 1.2m power lead and 3A three pin plug. Manufactured to **BS EN 60335-2-45**.



Wattage	Voltage	Order Code SEN-516	Price/1 TB
25W	230V	-2210K	823.00
40W	230V	-2240K	1029.00

Desoldering Pump

Single handed use. Quickly removes molten solder from joints. Smooth action sprung loaded piston. Nozzle easily removed for cleaning. Temperature resistant, can be placed directly onto solder. Anti-static body ensures excellent component protection.



Size (W x H x D) mm	Weight each	Order Code SEN-516	Price/1 TB
60 x 240 x 25	50g	-2160K	232.00

KENNEDY Desoldering Tool
QUALITY INDUSTRIAL TOOLING

Anti-Static Val-U-Vac

With carbon impregnated tip and body to prevent solder adhesion and dispel static. Conforms with **CECC 15**. Removal of molten solder is achieved by the spring loaded piston creating a vacuum in the barrel of the tool. With safety shield and extraction springs located outside of the vacuum chamber and PTFE nozzle to prevent solder sticking.

Nozzle size: 3mm OD x 1.5mm, ID x 20mm.



Overall Size	Weight each	Order Code KEN-516	Price/1 TB
190 x 20mm	40g	-8480K	1029.00

Professional Desoldering Tool

DSGPRM

Anodised aluminium body and steel plunger for professional use. With extraction spring located outside of the vacuum chamber and PTFE nozzle to prevent solder sticking. With safety shield.

Nozzle size: 3mm OD x 1.5mm, ID x 20mm long.



Size (mm)	Weight each	Order Code KEN-516	Price/1 TB
190 x 20	60g	-8500K	1391.00
Spare Nozzles (Pk 5)		-8505K	1166.00

Helping Hands

Ideal for precision soldering, wiring and model making applications. With 10 movable joints for universal adjustment. 50mm diameter x 2.5 magnification. Two spring loaded crocodile clips for holding objects up to 8mm thick. Solid cast iron base for stability. All other metal parts are chrome plated and corrosion-resistant.



Mag.	Mirror Size	Order Code KEN-516	Price/1 TB
2.5x	50mm Dia.	-1800K	476.00

HAND TOOLS



EDISON *Auto Range Digital Multimeters*

Within the Edison™ range of multimeters you will find direct reading multimeters and non-contact reading multimeters. Ideal for electrical troubleshooting and straightforward environmental testing in residential and commercial environments.

DAM075

The 2 in 1 digital multimeter is capable for the following tasks: electrical testing using test probes, no contact voltage detection and testing for wiring faults.

- Testing temperature:** -20 to 1000°C.
- AC voltage:** 750V.
- DC voltage:** 1000V.
- AC/DC current:** 10A.
- Resistance:** 40MΩ.
- Capacitance:** 200µF.

Relative measurement function. Diode testing facility. Clear display with LED back light and data hold function. Auto power OFF* and low power indicator.

Digital display count: 3999.

Pack includes: digital multimeter, test probes, temperature sensor probe, DC1.5V x3 AAA batteries (installed), instruction manual

Dimensions (W x D x H):
152 x 45 x 190mm.



Model Number	Weight each	Order Code EDI-516	Price/1 TB
DAM075	416g	-3100K	3553.00

MET060

The 5 in 1 digital multimeter is capable of testing the following: electrical testing.

- Temperature:** -20 to 1000°C.
- Humidity:** 30 to 90%.
- Sound level:** 35 to 100db.
- Illumination:** 4000 to 40000Lux.
- AC/DC voltage:** 600V.
- AC/DC current:** 10A.
- Resistance:** 40MΩ.
- Capacitance:** 200µF.
- Frequency:** 1Hz to 200KHz.

Relative measurement function. Diode testing facility. Clear display with LED back light and data hold function.

Auto power OFF* and low power indicator.

Digital display count: 3999.

Pack includes: environment digital multimeter, test probes, clamp-on test leads, temperature sensor probe, 9V battery (installed), instruction manual.

Dimensions (W x D x H):
165 x 65 x 230mm.



Model Number	Weight each	Order Code EDI-516	Price/1 TB
MET060	618g	-3460K	5722.00

MNT070

The 3 in 1 digital multimeter is capable of testing the following: network cable testing, line testing (RJ11), DMM testing.

- AC/DC voltage:** 1000V.
- AC/DC current:** 10A.
- Resistance:** 200MΩ.

Relative measurement function. Diode testing facility. Clear display with LED back light and data hold function.

Pack includes: network digital multimeter, test probes, TJ45 jack (remote), 9V battery (installed), instruction manual.

Dimensions (W x D x H): 165 x 65 x 230mm.



Model Number	Weight each	Order Code EDI-516	Price/1 TB
MNT070	618g	-3600K	4119.00

DAM100

Auto Range Hi-Accuracy Digital Multimeter with USB interface, ideal for electrical troubleshooting and straightforward maintenance, initial start-up testing and R and D.

- Linear frequency:** 5Hz to 200KHz.
- Logic frequency:** 5Hz to 2MHz.
- Duty cycle:** 5% to 95%.
- Diode testing:** 0 to 2.5V.
- AC/DC voltage:** 1000V.
- AC/DC current:** 10A.
- Resistance:** 50MΩ.
- Capacitance:** 5000µF.

Relative measurement function. Clear display with LED back light and data hold function auto power 'OFF' and low power indicator.

Digital display count: 50000.

Pack includes: digital multimeter, test probes, clamp-on test leads, USB interface connection, CD rom 'PC-LINK' software (compatible with Windows 98ME, 2000, NT or XP), 6x 1.5V AAA batteries (installed), instruction manual, protective case with carry strap.

PC-LINK software features: measure graph, measure data record, simulate LCD display, analogue dial plate display, measure max/min display, sampling interval, graph export, measure data save.

Dimensions (W x D x H):
178 x 65 x 255mm.

WITH PC LINK SOFTWARE



Model Number	Weight each	Order Code EDI-516	Price/1 TB
DAM100	1018g	-3420K	11279.00

DAM060

Auto Range Digital Multimeter with USB interface, ideal for electrical troubleshooting and straightforward maintenance, initial start-up testing and R and D.

- Temperature testing (K Type):** -5°C to 1000°C.
- AC voltage:** 700V.
- DC voltage:** 1000V.
- AC/DC current:** 10A.
- Resistance:** 60MΩ.
- Capacitance:** 300µF.
- Frequency/duty cycle:** 1Hz to 1MHz.

Diode testing and buzzer. Relative measurement function. Clear display with LED back light and data hold function.

Auto power 'OFF' and low power indicator. Auto/manual range. Electronic protection system.

Digital display count: 6000.

Pack includes: digital multimeter, test probes, temperature sensor, clamp-on test lead, USB Interface, CD rom 'PC-LINK' software (compatible with Windows 2000, NT or XP), 9V battery (installed), instruction manual.

PC-LINK software features: measure graph, measure data record, simulate LCD display, analogue dial plate display, measure max/min display, sampling interval, graph export, measure data save.

Dimensions (W x D x H):
165 x 65 x 230mm.

WITH PC LINK SOFTWARE



Model Number	Weight each	Order Code EDI-516	Price/1 TB
DAM060	182g	-3440K	7693.00

HAND TOOLS

EDISON Digital Multimeters

DM383

Features include continuity, transistor hFE, reading/peak hold, fused current range, auto power off, overload indication, low battery indication, tilt stand/hanger.

Voltage max: 600V AC, 600V DC.

Current max: 10A DC.

Resistance max: 2MΩ.

Safety rating: Cat II.

Warranty: 1 year.

Supplied with holster.



Model Number	Order Code	Price/1 TB
DM383	EDI-516	794.00
Replacement Probe	-9030K	170.00

DAM332

Pocket sized with integral lead storage. Features include continuity, diode, reading/peak hold, fused current range, auto power off, overload indication, low battery indication.

Voltage max: 600V AC, 600V DC.

Current max: 400mA AC/DC.

Resistance max: 40MΩ.

Safety rating: Cat II.

Warranty: 1 year.

Supplied with wallet.



Model Number	Order Code	Price/1 TB
DAM332	EDI-516	1203.00

DM664

Extra large digits, temperature probe and short lead capacitor adaptor. Features include continuity, diode, transistor hFE, auto power off, overload indication, low battery indicator, tilt stand/hanger.

Voltage max: 700V AC, 1000V DC.

Current max: 10A AC/DC.

Resistance max: 200MΩ.

Capacitance max: 2mF.

Frequency max: 20kHz.

Temp max: -20 to 1000°C.

Safety rating: Cat III 600V, Cat II 1000V.

Warranty: 1 year.



Model Number	Order Code	Price/1 TB
DM664	EDI-516	2295.00
Replacement Probe	-9010K	203.00

HAND TOOLS

DAM668

Removable rubber holster with integral lead holders. Features include continuity, diode, transistor hFE, auto ranging, reading/peak hold, bar graph, fused current range, overload indication, low battery indicator, tilt stand/hanger.

Voltage max: 700V AC, 1000V DC.

Current max: 10A AC/DC.

Resistance max: 32.6MΩ.

Capacitance max: 32.6mF.

Frequency max: 150kHz.

Safety rating:

Cat III 600V,

Cat II 1000V.

Warranty: 1 year.



Model Number	Order Code	Price/1 TB
DAM668	EDI-516	2781.00
Replacement Probe	-9010K	203.00

DAM982

Features include continuity, diode, auto ranging, reading/peak hold, back light, auto power off, overload indication, low battery indicator, tilt stand/hanger.

Voltage max: 750V AC, 1000V DC.

Current max: 10A AC/DC.

Resistance max: 40MΩ.

Capacitance max: 20μF.

Frequency max: 10MHz.

Safety rating:

Cat III 600V,

Cat II 1000V.

Warranty: 1 year.



Model Number	Order Code	Price/1 TB
DAM982	EDI-516	2295.00
Replacement Probe	-9020K	324.00

Non-Contact AC Voltage Detector

Non-contact voltage detector without the need to disconnect the conductor/ appliance. Flashing light and audible indication of AC voltages of 100 to 240V. Quick and accurate detection of cable breaks, blown fuses and distinguish between live, neutral wires in single and three phase supplies.

Voltage sensitivity:

100 to 240V AC.

Frequency: 50/60Hz.

Over voltage category:

Cat III 600V.

Detection distance: <5mm.

Operating temperature:

32 to 122°F (0 to 50°C).

Storage temperature:

-4 to 140°F (-20 to 60°C).

Humidity: <85%RH.

Power: batteries x2, 1.5V (AAA).

(EDI-904-3040K).

(Not supplied).



Model Number	Weight each	Order Code	Price/1 TB
NCD332	26g	EDI-516	514.00



EDISON Auto Range 1000A AC/DC Digital Clamp Meters

Edison™ multimeters are an essential and versatile piece of test equipment. They are used by qualified electricians and mechanics alike to perform various essential tests and measurements on delicate electronic systems, automotive devices, mains appliances, and installations. By operating the multi position switch you can quickly and easily set them to be a voltmeter, an ammeter or an ohmmeter. Within the Edison™ range of multimeters you will find direct reading multimeters and non-contact reading multimeters.

DCM070

Ideal for electrical troubleshooting and testing in commercial environments. The AC/DC digital multimeter is capable of testing for the following: telephone networks, fuse connections.

- AC voltage:** 750V.
- DC voltage:** 1000V.
- AC/DC current:** 1000A.
- Resistance:** 60MΩ.
- Frequency:** 100kHz.

Frequency from clamp: 400Hz.
Diode testing facility, continuity buzzer, clear display with LED backlight and data hold function, auto power 'OFF' and low power indicator, auto range facility, four segments bar graph.

Digital display count: 3999.
Conforms to **IEC 1010, CAT II 1000V** and **CAT III 600V**.

Pack includes: digital clamp multimeter, test probes, 3x DC1.5V AAA batteries (installed), instruction manual, protective case with carry handle,
Dimensions (W x D x H): 140 x 58 x 260mm.
Weight: 606g.



Model Number	Order Code	Price/1 TB
DCM070	EDI-516-3800K	5743.00

DCM070 True RMS

Ideal for electrical trouble-shooting and testing in commercial environments. The AC/DC digital multimeter is capable of testing for the following: telephone networks, fuse connections.

- AC voltage:** 750V.
- DC voltage:** 1000V.
- AC/DC current:** 1000A.
- Resistance:** 60MΩ.
- Frequency:** 100kHz.

Frequency from clamp: 400Hz.
Diode testing facility, continuity buzzer, clear display with LED backlight and data hold function, auto power 'OFF' and low power indicator, auto range facility, four segments bar graph.

Digital display count: 3999.
Conforms to **IEC 1010, CAT II 1000V** and **CAT III 600V**.

Pack includes: digital clamp multimeter, test probes, 3x DC1.5V AAA batteries (installed), instruction manual, protective case with carry handle.
Dimensions (W x D x H): 140 x 58 x 260mm.
Weight: 606g.



Model Number	Order Code	Price/1 TB
DCM070 True RMS	EDI-516-3840K	6072.00

EET01 Electrical Tester with LCD

Voltage Range: 12~690V AC/DC

Response Time: <0.5s at 100% of each nominal voltage

Accuracy (23±5°C): ±(3%+3) or 5V
Response Time: <2s at 90% of each voltage
Peak Current: <3.5mA (at 690V)

High voltage indication

Voltage Range: 100~690V AC

NEW

Continuity test: 0~1MΩ

Detection Range: 0~1MΩ

Test Current: Approx. 1.5µA (battery 3V, 0Ω)

Standard Category: IEC 61010-1

GS: CAT III 690V
ETL: CAT IV 600V
Pollution Degree: 2
IP code: IP64

Model Number	Order Code	Price/1 TB
EET01	EDI-516-4700K	2318.00



HAND TOOLS

OJM826 Open Jaw

Large digits, duty cycle function, relative measure. Features include continuity, diode, auto ranging, reading/peak hold, back light, auto power off, overload indication, low battery indicator, tilt stand/hanger.

- Voltage max:** 750V AC, 1000V DC.
- Current max:** 200A AC.
- Resistance max:** 40MΩ.
- Capacitance max:** 40µF.
- Frequency max:** 100kHz.

Safety rating:

Cat III 600V,
Cat II 1000V.

Warranty:

1 year.
Supplied with case.



Model Number	Order Code	Price/1 TB
OJM826	EDI-516-3500K	3466.00
Replacement Probe	-9040K	324.00

Universal Multimeter Test Leads

1 pair (Red, Black) test leads with right handed shrouded banana plug connectors. CATII 1000V 10A. Non fused.

Suitable for use with any 4mm multimeter/instrument for general purpose measurements.

Product Number	ETL901	ETL902	ETL903	ETL904
Probe Length (on both) Red/Black	145mm	145mm	120mm	160mm
Lead Lengths Pair - Red/Black	800mm	800mm	650mm	800mm
Connectors	Right Angled Shrouded Banana Lug	Right Angled Shrouded Banana Lug	Right Angled Shrouded Banana Short 15mm Lug	Right Angled Shrouded Banana Lug
End Cap Protectors	Plastic	Plastic	Plastic	Plastic
Fuse	No	No	No	No
Use	Any 4mm multimeter/instrument for general purpose measurement			
Order Code	EDI-516-9010K	EDI-516-9020K	EDI-516-9030K	EDI-516-9040K

Edison Multimeter Compatibility

	DM664/DAM668	DAM982	DM383	OJM826
Order Codes	EDI-516-3000K/EDI-516-2700K	EDI-516-3700K	EDI-516-2900K	EDI-516-9040K

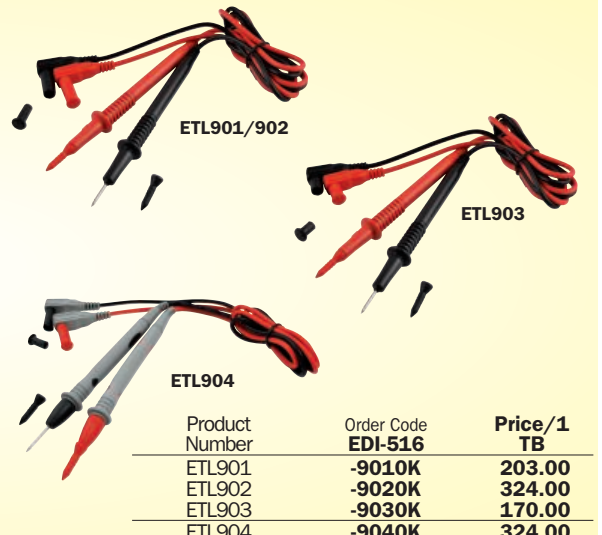

Product Number	Order Code	Price/1 TB
ETL901	-9010K	203.00
ETL902	-9020K	324.00
ETL903	-9030K	170.00
ETL904	-9040K	324.00

PRODUCTS ARE ONLY AVAILABLE VIA YOUR DISTRIBUTOR

GROUP 516 MULTIMETERS

EDISON Infrared Digital Thermometer with Laser Targeting

IRT537

A high resolution infrared laser thermometer suitable for a wide range of industrial applications, HVAC and automotive diagnostics. The laser targeting enables accurate readings by guiding the user to the optimum measuring distance, please see user manual for operating instructions. Ideally suited for work in confined spaces and where accuracy is required such as on bearings, circuit boards, air-con units or in engine compartments. Simply aim at the target object, pull the trigger mechanism and read the current surface temperature from the LCD display. If necessary the laser can be activated via the laser button for more accurate targeting. Temperature is displayed on back-lit LCD display and features hold function for ease of use.

Measurement range: -20°C to 537°C.

Accuracy: -20°C to 50°C

±2.5°C 51°C to 537°C

±(reading x 1% 1°C).

D/S ratio: 12:1.

Emissivity: 0.95.

Celsius/Fahrenheit

display selection.

Back light display.

Power source: 9V battery.

Average/maximum/

minimum/maximum-minimum

mode selection.

Complies with:

EN61326:1997/A1:1998/

A2:2001/A3:2003.

Dimensions (L x W x H):

162 x 56 x 190mm.



Model Number	Order Code	Price/1 TB
IRT537	-4000K	4378.00

Relative Humidity & Temperature Tester

THM150

This multimeter is ideal for temperature, humidity and dew point testing in residential and commercial environments such as offices, storerooms, greenhouses and places where a controlled environment is essential.

Conforms with **EN61326-6: 2006 and EN61326-2-2: 2006.**

Meter capabilities:

- Testing temperature: -10 ~ 50°C (14 to 122°F).
- Testing humidity: 0 ~ 100%RH.
- 4 digit clear LCD display with optional back light.
- Data hold function.
- Auto power 'OFF' and low power indicator.
- Battery operated - DC1.5V 3x AAA (included).



Model Number	Order Code	Price/1 TB
THM150	-4040K	3735.00

Airflow, Velocity & Temperature Tester

TVA150

This meter is for measuring airflow and temperature. It is ideally used to measure the air speed at ventilation outlets and to test temperatures in residential and commercial environments such as offices, storerooms, greenhouses and places where climate conditions can be analysed.

Conforms with **EN61326-6: 2006 and EN61326-2-2: 2006.**

Meter capabilities:

- Measuring wind/airflow in: m/s, km/h, fpm, mph, kts.
- Beaufort scale.
- Temperature in both °C and °F.

Testing ranges: 0.4 ~ 20m/s, 80 ~ 4000fpm, -10 ~ 50°C (14 ~ 122°F).

- 4 digit clear LCD display with optional back light.
- Data hold function.
- Auto power 'OFF' and low power indicator.
- Battery operated - DC1.5V 3x AAA (included).



Model Number	Order Code	Price/1 TB
TVA150	-4020K	4929.00



Electronic Tachometer

TNC150

Precise red LED light source (laser beam) together with a reflective strip, non-contact measurements can be made safely up to 40cm (15¾") from the target.

For measuring in rpm and rps.

Conforms with **EN61326-6: 2006 and EN61326-2-2: 2006.**

Testing range: 100 to 30000rpm/1.7 to 500rps.

6 digit clear LCD display with optional back light.

Data hold function.

Auto power 'OFF' and low power indicator.

Battery operated: DC1.5V 3x AAA (included).



Model Number	Order Code	Price/1 TB
TNC150	-4200K	4069.00



HAND TOOLS

KENNEDY *Edge & Centre Finders*
QUALITY INDUSTRIAL TOOLING

Cylinder Type

For fast accurate work location. Made from tool steel and hardened all over, they can be used on flat surfaces, straight edges, shoulders, grooves, studs, dowels, centre points and scribed lines.

To locate an edge first secure the finder in a collet or chuck, the work table is then traversed to cause the rotating edge finder to make contact with the workpiece. (**fig 1**).

Upon touching the workpiece the edge finder's contact point will be forced into running concentrically with the body (**fig 2**). Any further movement to 'off-centre' will cause a distinct wobble.

At this point, the distance from the work edge to the centre of the finder is equal to half the diameter of the contact point. Datum lines and centre points are located using the combination edge and centre finder (**fig 3**).

This has a cone shaped contact point which is lowered into position barely touching the workpiece at the point you wish to measure. The finder is made to run concentrically using a steel rule or straight edge (**fig 4**).

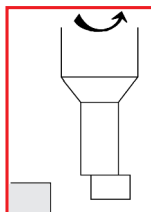

fig 1

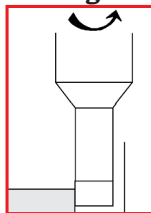

fig 2

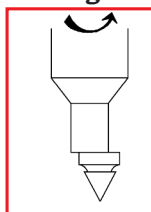

fig 3

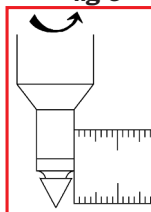

fig 4

Edge & Centre Finder - 5 Piece Set

Consists of a chuck body and four contact arms. Designed to check 'run-out' or concentricity, straightness and alignment. Will indicate the position of a datum point on a component or fixture from the centre line of a machine spindle. Suitable for use on drill presses, lathes, milling machines, borers etc.

Chuck Body:

Held in the spindle using a suitable drill chuck or collet chuck (**fig 1**). The contact arms are retained in position using the knurled collar which lightly clamps the ball joint inside the body. Arms may be exchanged without the need to remove the body from the machine spindle.

Universal Indicator Holder

The detachable end will allow clamping with 2 and 3 piece dovetail clamping assemblies and when removed will fit standard 1/4" side clamp. This uses the spindle centre line to align component bores or spigots, check the flatness or squareness of workpieces or fixturing and check run-out of components. The spindle should only be rotated manually to avoid damaging the dial test indicator (**fig 1**).

Needle Point

To lightly mark out lines and positions on a component as a guide to subsequent operations, using the machine's dials or digital read-out to position the scribe point (*not illustrated*).

Clamping Assemblies

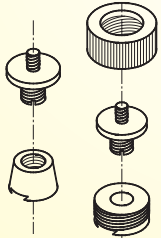

2 Piece 3 Piece



fig 1

Ball Contact .250"

Used to find a datum point .125" ± .0005" away from a flat surface.

Disc Contact .100"

Used to find a datum point .050" ± .0005" away from a convex surface.

Edge Finders



Description	Diameter	Weight each	Order Code KEN-518	Price/1 TB
Shank	0.200"			
Body	0.375"	30g	-1410K	399.00
Shank	10mm			
Body	10mm	40g	-1420K	422.00
Shank	0.200"			
Body	0.500"	40g	-1430K	422.00

Edge & Centre Finders Combination



Description	Diameter	Weight each	Order Code KEN-518	Price/1 TB
Shank	0.200"			
Body	0.500"	50g	-1440K	509.00
Shank	0.200"			
Body	0.375"	30g	-1450K	509.00
Shank	5mm			
Body	12mm	40g	-1445K	509.00

Double Edge



Description	Diameter	Weight each	Order Code KEN-518	Price/1 TB
Shank	0.200"			
Body	0.500"	60g	-1460K	384.00

Plain Edge



Description	Diameter	Weight each	Order Code KEN-518	Price/1 TB
Shank	0.500"			
Body	0.500"	60g	-1470K	308.00
Shank	12mm			
Body	12mm	50g	-1480K	308.00

Position the contact arm in line, but slightly away from the surface to be aligned. When finding the surface of a diameter, the 'Disc' must be positioned as near to the centre of that diameter as possible. Run the spindle between 200 and 500 revs/min. The table or spindle is then moved slowly, to bring the contact arm closer to the surface to be aligned. The contact arm will tap lightly against the surface (**fig 2**) the movement of the arm will become less and less the nearer the datum point gets to the spindle centre line (**fig 3**). When the arm stops spinning in a straight line and starts to 'jump', this indicates the datum point (**fig 4**):

$\frac{1}{2}$ contact dia + Edge = Centre $\frac{1}{2}$ contact dia - Centre = Edge

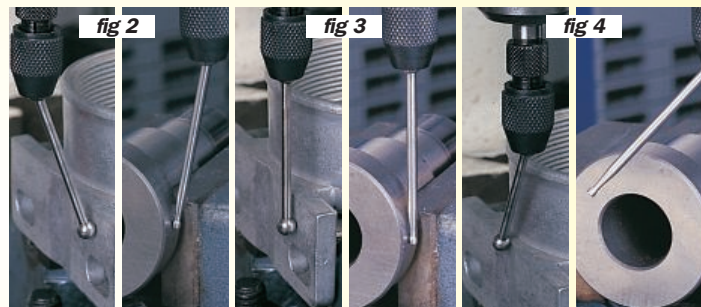

Contents	Weight each	Order Code KEN-518	Price/1 TB
As Above	130g	-1500K	514.00

HAND TOOLS

GROUP 518 ENGINEER'S HAND TOOLS



Engineer's Rule Round End - Pocket Type



Spring tempered stainless steel blades. 13mm blade width with pocket clip/depth gauge slide. Reverse side is marked with 1/64" to mm conversion table. 12mm blade width. Can also be used as a depth gauge.



Anti Glare Satin Chrome Rustless	Scale Type	Length	Order Code KEN-518	Price/1 TB
	Metric & Inch	150mm/6"	-3510K	174.00



Engineer's Rule Round End - Pocket Type



Spring tempered stainless steel blades. 12mm blade width with pocket clip/depth gauge slide. Reverse side is marked with 1/64" to mm conversion table.



Stainless Steel Rustless	Scale Type	Length	Order Code SEN-518	Price/1 TB
	Metric & Inch	150mm/6"	-3500K	163.00



Engineer's Steel Rules

EEC CLASS I ACCURACY



Finest quality spring tempered stainless steel. Satin chrome. Anti-glare finish with permanent black figures and graduations. Extremely easy to read. Accuracy: ± 0.2mm full scale. Constant at 20°C. Rustless.

Round End

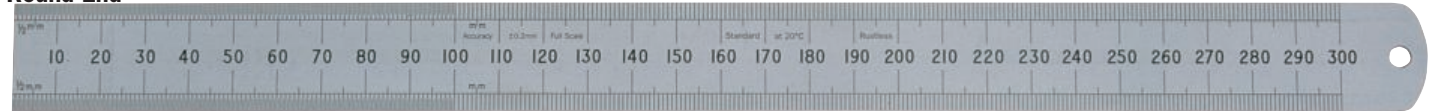

Round End - Flexible Blade

Spring tempered flexible steel blades. 12mm blade width. With hanging hole.

Anti Glare Satin Chrome Rustless

Scale Type	Length	Order Code KEN-518	Price/1 TB
Metric	150mm/6"	-3010K	292.00
& Inch	300mm/12"	-3210K	476.00
Metric only	150mm	-3030K	185.00
	300mm	-3230K	476.00

Flexible Blade - Metric - subdivided to 0.5mm and 1mm, figured every 10mm.

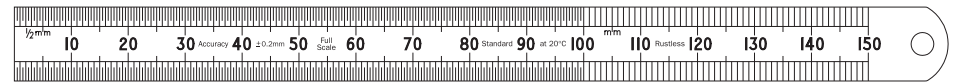

Flexible Blade - Inch - subdivided to 1/16", 1/32" and 1/64", figured every inch.

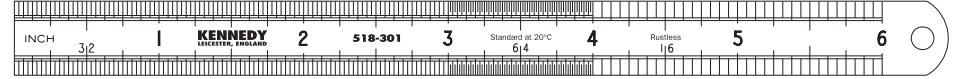

Round End - Rigid Blade

Spring tempered rigid steel blades. 150mm/6" = 19mm blade width. Other lengths = 25mm blade width. With hanging hole.

Scale Type	Length	Order Code KEN-518	Price/1 TB
Metric	150mm/6"	-3110K	243.00
& Inch	300mm/12"	-3310K	507.00
	600mm/24"	-3710K	1041.00
	1000mm/39"	-3910K	2729.00
Metric only	150mm	-3130K	248.00
	300mm	-3330K	458.00
	600mm	-3730K	1002.00
	1000mm	-3930K	1774.00

Rigid Blade - Metric - subdivided to 0.5mm and 1mm, figured every 10mm.

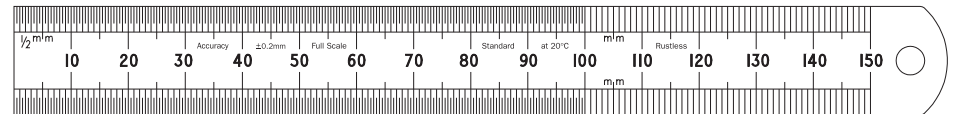

Rigid Blade - Inch - subdivided to 1/16", 1/32" and 1/64", figured every inch.

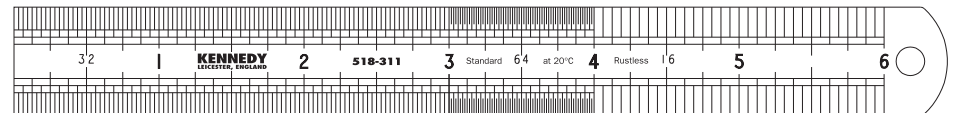

Square End



Square End - Flexible Blade

Spring tempered flexible steel blades. 12mm blade width.

Anti Glare Satin Chrome Rustless

Scale Type	Length	Order Code KEN-518	Price/1 TB
Metric & Inch	150mm/6"	-3020K	243.00

Flexible Blade - Metric - subdivided to 0.5mm and 1mm, figured every 10mm.

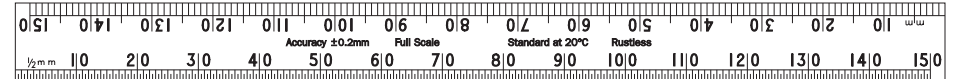

Flexible Blade - Inch - subdivided to 1/16", 1/32" and 1/64", figured every inch, every 8/64", and every 4/32".

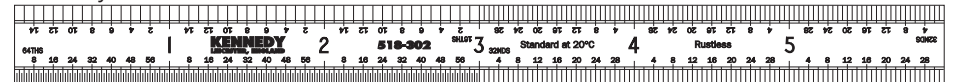

Square End - Rigid Blade

Spring tempered rigid steel blades. 150mm/6" = 19mm blade width. 300mm/12" = 25mm blade width.

Scale Type	Length	Order Code KEN-518	Price/1 TB
Metric	150mm/6"	-3120K	322.00
& Inch	300mm/12"	-3320K	610.00

Rigid Blade - Metric - subdivided to 0.5mm and 1mm, figured every 10mm.

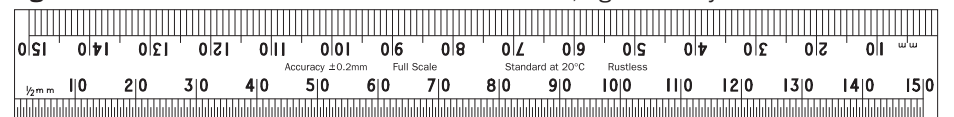

Rigid Blade - Inch - subdivided to 1/16", 1/32" and 1/64", figured every inch, every 8/64", and every 4/32".

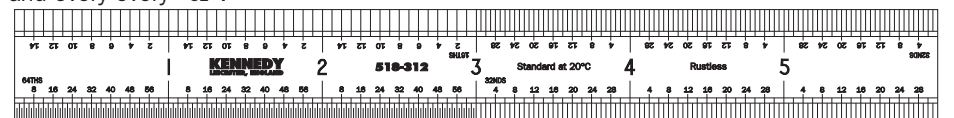

HAND TOOLS

KENNEDY Brass Counter Measure
QUALITY INDUSTRIAL TOOLING

A robust measuring tool manufactured from hard rolled brass with permanent black figures and graduations. Flexible and rustless, it has a 19mm wide blade and countersunk fixing holes.

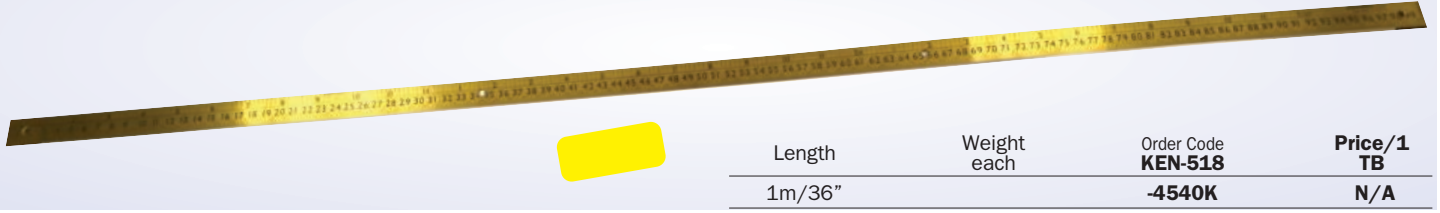

Length	Weight each	Order Code KEN-518	Price/1 TB
1m/36"		-4540K	N/A

Tapered Gauges

These are called taper gauges only because of their shape - they do not measure tapers. They are ideally suited for the rapid accurate checking of the inside diameters of tubing, slot widths, hole sizes, setting calipers etc. Manufactured from spring tempered steel. 0.1mm increments. Rustless. Constant at 20°C. Satin chrome anti glare finish. Permanent black figures and graduations.

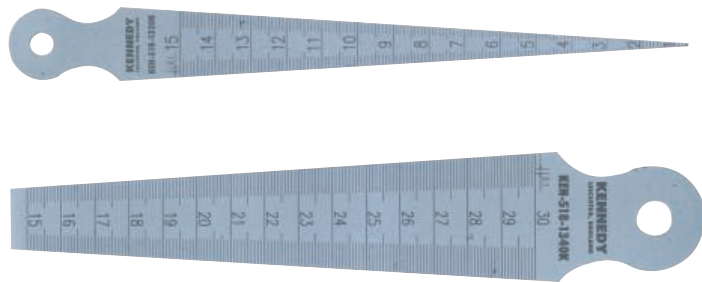

Range (mm)	Weight each	Order Code KEN-518	Price/1 TB
1 - 15	18g	-1320K	713.00
15 - 30	36g	-1340K	762.00

Line of Chords Rule

This precision tool has a line of chords scale for use in measuring angles and in determining the circumference of a circle from a diameter measurement. The rule is flexible and rustless with deep etched figures filled with black ink.



Length	Weight each	Order Code KEN-518	Price/1 TB
600mm/24"		-2980K	N/A

Folding Steel Rule

This folding steel rule is manufactured from spring tempered stainless steel with a polished finish and it is both flexible and rustless. A strong, solid performer for the engineer. Subdivided to mm, figured cm one side. Inch - subdivided to 1/16", figured 1" other side.

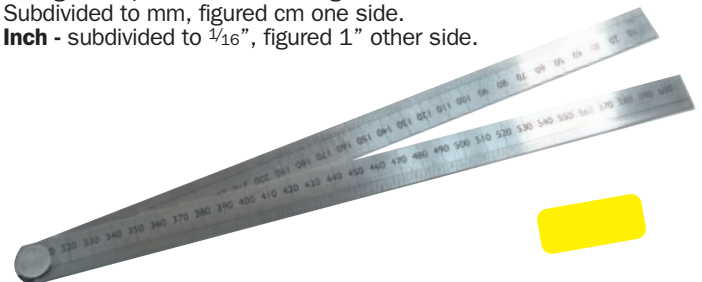

Length	Weight each	Order Code KEN-518	Price/1 TB
600mm/24"		-2950K	N/A

Tweezers

For workshop and home use. Cross pattern types are self closing and open only under applied pressure. High quality finish supplied singly or as a six piece set.

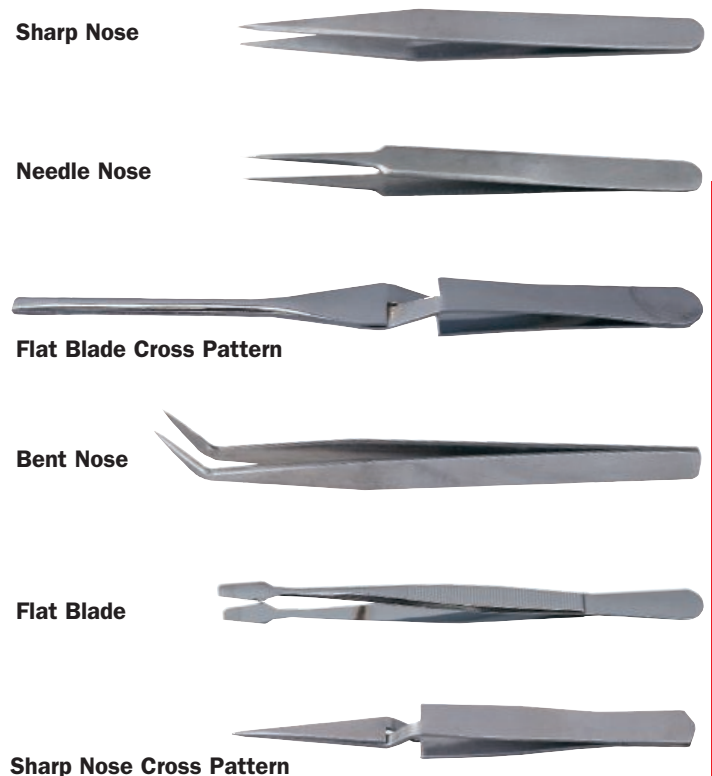

Type	Length (mm)	Weight each	Order Code KEN-518	Price/1 TB
Sharp Nose	115	20g	-5100K	147.00
Needle Nose	115	20g	-5120K	235.00
Flat Blade Cross	170	30g	-5140K	261.00
Bent Nose	145	30g	-5160K	235.00
Flat Blade	120	20g	-5180K	182.00
Sharp Nose Cross	115	20g	-5200K	182.00
Set of 6 (1 of each above)		134g	-5250K	1144.00

SENATOR Carpenter's Rules
QUALITY TOOLING

Extremely lightweight extrusion made from anodised aluminium, hardened and lacquered. Graduated mm/1/8". Supplied in clear plastic wallets.



Measured Length	Weight each	Order Code SEN-518	Price/1 TB
150mm/6"	33g	-3600K	119.00
300mm/12"	62g	-3620K	162.00
600mm/24"	124g	-3640K	271.00
1000mm/39"	191g	-3660K	384.00

GROUP 518 ENGINEER'S HAND TOOLS

KENNEDY Adjustable Steel Squares
QUALITY INDUSTRIAL TOOLING

Made from hardened steel and precision ground. Supplied with three fully adjustable blades. One plain, parallel blade for use as a conventional engineer's square, 30° and 45° bevel edged blade for checking angles, and a narrow blade graduated metric and imperial.

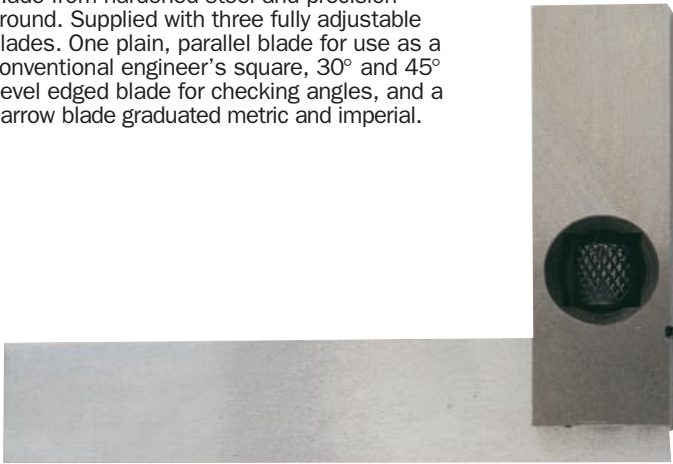

Measured Length	Weight each	Order Code KEN-518	Price/1 TB
100mm/4"	340g	-4150K	2282.00
150mm/6"	410g	-4160K	2575.00

OXFORD PRECISION Engineer's Squares

Manufactured from hardened steel that has been precisely ground to produce parallel edges so that the square has an exact right angle on both the inside and outside of the stock and blade, to ensure accuracy. Conforms to **BS939 Grade B**.



Size (mm)	tol. (mm)	Order Code OXD-340	Price/1 TB
75 (3")		-0030K	1191.00
100 (4")		-0040K	1500.00
150 (6")	+/- 0.016	-0060K	1575.00
225 (9")		-0090K	3605.00
300 (12")	+/- 0.024	-0120K	4635.00

Engineer's Squares

Manufactured from hardened and tempered steel. The edges are ground parallel to give the square an exact right angle on both the inside and outside of the stock and blade.

Squareness tolerance:

75mm, 100mm and 150mm = +/- 0.030mm,
225mm and 300mm = +/- 0.040mm.



*Supplied in robust case.

Size (mm)	Weight each	Order Code KEN-518	Price/1 TB
75 (3")*	140g	-4620K	1270.00
100 (4")*	270g	-4640K	1270.00
150 (6")*	320g	-4660K	1698.00
225 (9")	1400g	-4680K	3278.00
300 (12")	2000g	-4700K	4229.00

Telescopic Gauges

With knurled satin finish bodies providing positive adjustment of the hardened and radius ground plungers ensuring accurate measurement of the internal diameter when used with a micrometer. For smaller diameter measurements use the small hole gauge.

6 PIECES



Range (mm)	Length (mm)	Order Code KEN-518	Price/1 TB
8 - 12 5/16" - 1/2"	115	-1174K	290.00
12 - 19 1/2" - 3/4"	115	-1175K	296.00
19 - 32 3/4" - 1 1/4"	115	-1176K	307.00
32 - 54 1 1/4" - 2 1/8"	137	-1177K	322.00
54 - 90 2 1/8" - 3 1/2"	137	-1178K	333.00
90 - 150 3 1/2" - 6"	137	-1179K	352.00

Set

Supplied in a size marked PVC storage wallet, with stud fastening. Contains 1 of each size A - F inclusive.

Set range:	Weight each	Order Code KEN-518	Price/1 TB
8 - 150mm (5/16" - 6").	425g	-1180K	1669.00

HAND TOOLS

KENNEDY Firm Joint Calipers
QUALITY INDUSTRIAL TOOLING

Manufactured from high quality steel, with a polished finish. Consisting of two legs which are held together by a large nut and screw to provide a firm friction joint. Each firm joint caliper has an adjustable ground point which can be retracted for storage and the other leg is angled at the tip. The legs can be reversed, so the tip turns inwards or outwards. Firm joint calipers are used for scribing arcs and parallel lines by using the edge of the workpiece as a guide, and are also used for measuring from the centre point of a component.

Adjustable Point



Size (mm)	Weight each	Order Code KEN-518	Price/1 TB
100 (4")	60g	-0530K	695.00
150 (6")	80g	-0540K	1043.00

Firm Joint Caliper

Manufactured from high quality steel, with a polished finish. Consisting of two legs which are held together by a large nut and screw to provide a firm friction joint. This firm joint caliper has an adjustable ground point which can be retracted for storage and the other leg is angled at the tip. The legs can be reversed, so the tip turns inwards or outwards. Firm joint calipers are used for scribing arcs and parallel lines by using the edge of the workpiece as a guide, and are also used for measuring from the centre point of a component.

Adjustable Point & Spur



Size (mm)	Weight each	Order Code KEN-518	Price/1 TB
130 (5")	55g	-0550K	1053.00

Spring Divider & Caliper Set

Contents:
6" spring divider, 6" internal caliper and 6" external caliper.

**3
PIECES**



Number of Pieces	Weight each	Order Code KEN-518	Price/1 TB
3	350g	-0580K	2361.00

Spring Dividers

Manufactured from high quality polished steel. Ground finished points, a fine adjusting screw is mounted across the legs for setting the distance between the two points. A circular spring bow joins the legs, with a knurled extension attached for use when pivoting the dividers. Dividers are used for scribing arcs and circles, align centre punch mark on the work keeps the pivot leg in the centre while marking.



Capacity (mm)	Weight each	Order Code KEN-518	Price/1 TB
75 (3")	50g	-0030K	658.00
100 (4")	60g	-0040K	644.00
150 (6")	95g	-0060K	701.00
200 (8")	115g	-0080K	865.00
250 (10")	180g	-0100K	1072.00
300 (12")	200g	-0120K	1250.00

Internal & External Spring Calipers

Manufactured from high quality polished steel with ground finished points. A circular spring bow joins the legs and a fine adjusting screw is mounted across the legs and is used for setting the distance between the two points.

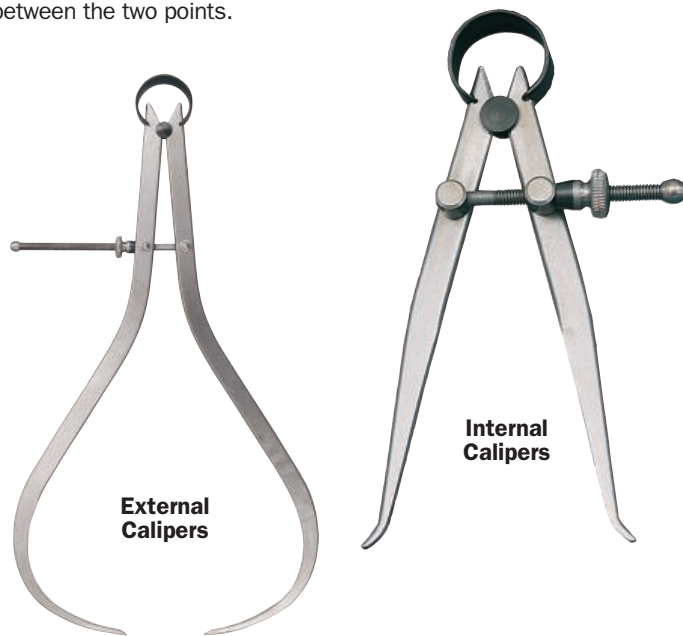

Capacity (mm)	Weight each	Order Code KEN-518	Price/1 TB
Internal Calipers			
75 (3")	50g	-0230K	628.00
100 (4")	50g	-0240K	651.00
150 (6")	90g	-0260K	712.00
200 (8")	110g	-0280K	874.00
255 (10")	170g	-0300K	1078.00
305 (12")	195g	-0320K	1263.00
External Calipers			
75 (3")	50g	-0430K	617.00
100 (4")	50g	-0440K	651.00
150 (6")	120g	-0460K	712.00
200 (8")	120g	-0480K	874.00
255 (10")	190g	-0500K	1078.00
305 (12")	225g	-0520K	1263.00

HAND TOOLS



Depth & Angle Gauges

Plain Type Depth Gauge

Designed for measuring flat based recesses. Consisting of a precision ground steel rule and body which are positioned at 90° to each other. The body has precision ground locating faces, with a knurled adjusting/securing nut.

Protractor Type Depth & Angle Gauge

Ground steel with graduations from 0° - 180° in both directions for fast and accurate measurements. When the rule is positioned to 90° on the protractor it then provides accurate measurements of depth.

Plain type

Protractor type

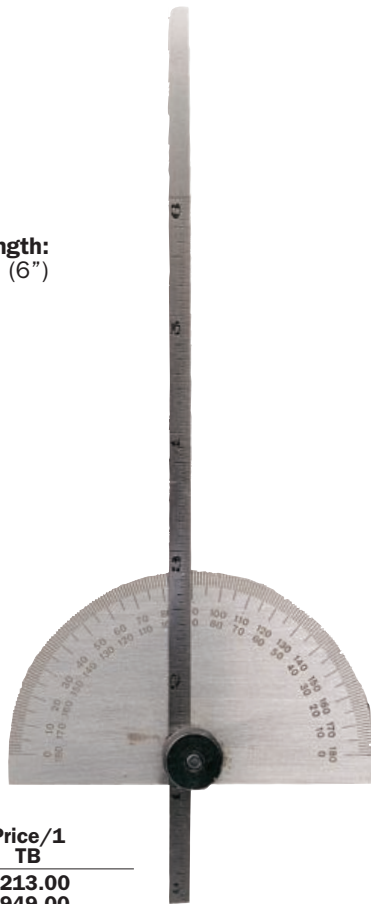
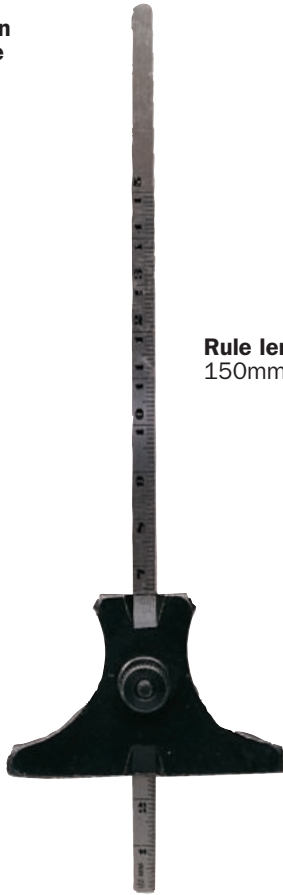

Rule length: 150mm (6")

Type	Order Code KEN-518	Price/1 TB
Plain	-3400K	1213.00
Protractor	-3450K	949.00

Radius Gauges

Manufactured from hardened and polished steel, the blades are precision milled for optimum accuracy when measuring internal and external radii. Enclosed in a steel case.

Size range:

- 34 Blade Metric: 1.0 to 3.0 x .25 and 3.5 to 7.0 x .5
- 32 Blade Metric: 7.5 to 15.0 x .5
- 32 Blade Inch: 17/64" to 1/2" x 1/64"
- 30 Blade Metric: 15.5 to 20.0 x .5 and 21.0 to 25.0 x 1
- 30 Blade Inch: 1/32" to 1/4" x 1/64".



No. of Blades	Weight each	Order Code KEN-518	Price/1 TB
34M	70g	-0820K	712.00
32M	80g	-0850K	738.00
32I	120g	-0940K	1176.00
30M	95g	-0890K	821.00
30I	70g	-0920K	1034.00

Screw Cutting Gauge

Manufactured from hardened and polished steel to check BA, Whitworth and BSF, Acme and American Screw Threads.

Angles: 60° American and Metric, 55° Whit and BSF, 47 1/2° BA and 14 1/2° Acme.



Type	Order Code KEN-518	Price/1 TB
Screw Gauge	-0800K	268.00

Screw Pitch Gauges

Ideal for accurately measuring internal and external thread forms. Manufactured from hardened and polished steel, the blades are precision milled for optimum accuracy. Enclosed in a steel case.

Range of sizes:

- Whitworth - 4 - 62 TPI;
- Metric - 0.75 - 6mm;
- American - 4 - 42 TPI.

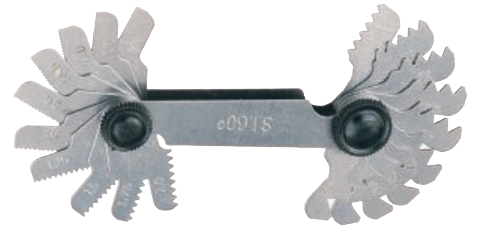

Type	No. of Blades	Order Code KEN-518	Price/1 TB
55° Whit.	28	-1000K	258.00
60° Metric	20	-1010K	268.00
60° USA	30	-1070K	301.00

Drill Gauges

Manufactured from hardened steel with a satin finish. An ideal way to quickly measure the diameter of drills and steel wire.

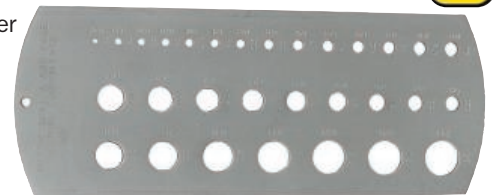

Range of sizes	Order Code KEN-518	Price/1 TB
1.5 - 12.5mm	-1130K	1829.00
1/16" - 1/2"	-1140K	1372.00

1 - 60 Gauge

Measures drill sizes Nos 1 - 60. Holes are marked with size and decimal equivalent of drill.



Range of sizes	Order Code KEN-518	Price/1 TB
No. 1 - 60	-1100K	1029.00

Standard Wire Gauges

Manufactured from high grade tool steel with satin brushed finish. Each slot is marked with the nominal size. Two part pivoting space saving design.



Range of sizes	Order Code KEN-518	Price/1 TB
1 - 36SWG	-1160K	979.00
0.2 - 10.0mm	-1165K	886.00

HAND TOOLS



KENNEDY Feeler Gauges
QUALITY INDUSTRIAL TOOLING

Hardened and polished taper blades, enclosed in a steel case. Blades are clearly marked for easy identification.

Metric: Manufactured to **BS 957: 2008 Part 1**

Part 1 (Metric).

Range:

10 Blade: .05 - .80mm.

13 and 20 Blade: .05 - 1mm.



Number of Blades	Weight each	Order Code KEN-518	Price/1 TB
10	55g	-0710K	165.00
13	70g	-0740K	215.00
20	100g	-0780K	345.00

Inch: Manufactured to **BS 957: 2008 Part 1. 4" Blade length.**

Range:

10, 18 and 26 Blade:

.0015" - .025".



Number of Blades	Weight (mm)	Order Code KEN-518	Price/1 TB
10	40g	-0610K	165.00
18	65g	-0650K	301.00
26	90g	-0690K	400.00

Double Ended Feeler Gauge

Hardened and polished taper blades enclosed in a steel case. Blades are clearly marked.

Metric & Inch: To **BS957: 2008 Part 1 (Inch)** and **BS957: 2008 Part 1 (Metric)**.

75mm/6" blade length.

Range: 18 Blade: 0.05" - 0.025".



Number of Blades	Weight (mm)	Order Code KEN-518	Price/1 TB
18	60g	-0790K	280.00

SENATOR QUALITY TOOLING



Double Ended Feeler Gauge

Hardened and polished. Blade etched with size. Manufactured to **BS957: 2008 Part 1 (Inch)** and **BS957:1969 Part 1 (Metric)**.

Blade length: 75mm.

No.75 18 Blade:

Metric range: 0.05 - 0.5mm.

Inch range: 0.0015" - 0.025".



Number of Blades	Weight each	Order Code SEN-518	Price/1 TB
18	60g	-5790K	398.00

Feeler Stock Strip

Inch sizes are 12" long, 1/2" wide. Millimetre sizes are furnished in 300mm lengths, 12.7mm wide. Rounded ends. Each piece marked with thickness and with convenient 3/16" (5mm) hole for hanging.



Thickness (mm)	Weight per 10	Order Code KEN-519	Price/1 TB
12.7mm x 300mm			
0-03	15g	-1030K	91.00
0-04	15g	-1040K	99.00
0-05	15g	-1050K	99.00
0-06	20g	-1060K	100.00
0-08	25g	-1080K	107.00
0-10	30g	-1100K	120.00
0-15	45g	-1150K	139.00
0-20	60g	-1200K	139.00
0-25	75g	-1250K	139.00
0-30	80g	-1300K	139.00
0-40	120g	-1400K	139.00
0-50	150g	-1500K	139.00
1/2" x 12"			
0-0010"	60g	-0020K	63.00
0-0015"	20g	-0030K	76.00
0-0020"	20g	-0040K	88.00
0-0025"	20g	-0050K	100.00
0-0030"	30g	-0060K	114.00
0-0040"	40g	-0080K	125.00
0-0050"	40g	-0100K	139.00
0-0060"	40g	-0120K	46.00
0-0070"	60g	-0140K	70.00
0-0080"	70g	-0160K	70.00
0-0090"	70g	-0180K	76.00
0-0100"	80g	-0200K	76.00
0-0120"	90g	-0240K	76.00
0-0150"	110g	-0300K	82.00
0-0200"	150g	-0400K	82.00
0-0250"	200g	-0500K	82.00

Feeler Stock Coil

Also useful for shimming in fixture and die work. Supplied in a compact, sturdy plastic rewindable dispenser case. Rewind feature, minimises accidental damage. Made of the finest tempered steel, marked every 6" or 150mm with a line, thickness in thousandths of an inch or in hundredths of a mm.



Thickness (mm)	Weight each	Order Code KEN-519	Price/1 TB
12.7mm x 6m			
0-03	60g	-3030K	1119.00
0-04	70g	-3040K	1119.00
0-05	75g	-3050K	1119.00
0-10	110g	-3100K	1119.00
0-20	230g	-3200K	1119.00
0-50	390g	-3500K	1119.00
1/2" x 25ft			
0-0010"	100g	-2020K	1029.00
0-0015"	60g	-2030K	1029.00
0-0020"	70g	-2040K	1029.00
0-0030"	90g	-2060K	1029.00
0-0040"	110g	-2080K	1029.00
0-0050"	135g	-2100K	1029.00
0-0060"	150g	-2120K	1029.00
0-0100"	220g	-2200K	1029.00
0-0150"	360g	-2300K	1029.00
1/2" x 20ft			
0-0200"	430g	-2400K	1029.00
0-0250"	500g	-2500K	1029.00

Small Hole Gauge Set

Range 3mm (1/8") to 13mm (1/2")

The knurled handle allows fine adjustment of the gauge within the workpiece.

Use in conjunction with a micrometer to accurately measure internal dimensions.

Contents: 90, 99, 110 and 110mm overall length.

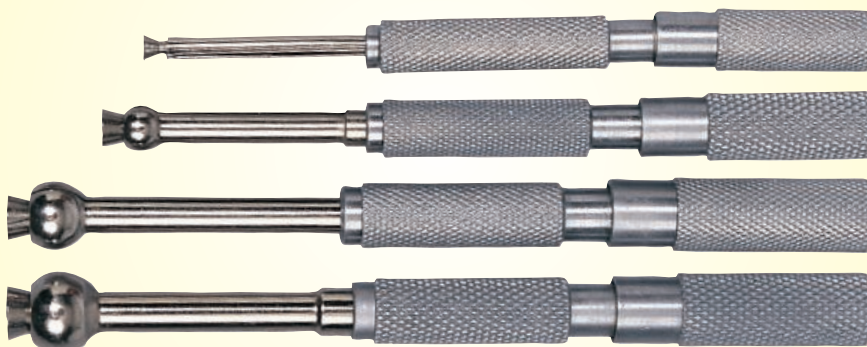

4 PIECES

Number of Pieces	Order Code KEN-518	Price/1 TB
4	-1150K	1101.00

GROUP 518 ENGINEER'S HAND TOOLS

KENNEDY Automatic Centre Punches
QUALITY INDUSTRIAL TOOLING

Light Duty

Delivers a punch when head is depressed. Chrome vanadium tip with rubber sheathed steel body.



Length (mm)	Impact Weight (kg)	Order Code KEN-518	Price/1 TB
140	1.5 - 5.0	-1750K	1350.00
Spare Point		-1800K	230.00

Standard Duty

Strength of punch and depth of depression is adjustable by turning the knurled head. Delivers a punch between 2.25 to 13.5kg (5 to 30lb).



Length (mm)	Impact Weight (kg)	Order Code KEN-518	Price/1 TB
120	2.25 - 13.5	-1710K	1591.00

Heavy Duty

Strength of punch and depth of depression is adjustable by turning the knurled head. Delivers a punch between 6.3 to 22.5kg (14 to 50lb).



Length (mm)	Impact Weight (kg)	Order Code KEN-518	Price/1 TB
149	6.30 - 22.5	-1720K	2606.00

Square Head Centre Punches

Non-roll. Manufactured from hardened and tempered steel with a knurled body for positive grip. Precision ground 60° point for accurate marking of workpiece. Conform to BS 3066.



4 PIECES

*Round headed.

Point Diameter (mm)	Order Code KEN-518	Price/1 TB
100mm (4") Overall Length		
3.2 (1/8")	-2050K	111.00
4.0 (5/32")	-2060K	111.00
4.8 (3/16")	-2070K	121.00
6.3 (1/4")	-2090K	121.00
125mm (5") Overall Length		
6.3 (1/4")	-2110K	151.00
9.5 (3/8")*	-2120K	177.00

Set

Supplied in plastic wallet.

Contents: 1x 3.2, 4, 4.8 and 6.4 x 100mm.

Number of Pieces	Order Code KEN-518	Price/1 TB
4	-2100K	442.00

Centre Punches

Ideal for driving tight fitting pins out of mechanical assemblies or realigning holes to fit dowel pins. Made from chrome vanadium steel with high strength octagonal shanks and featuring cushioned grip handles with shock absorbing air pockets.

Overall length: 150mm (6").



NEW

Point Dia. (mm)	Order Code KEN-518	Price/1 TB
2.0	-2332K	227.00
3.0	-2333K	227.00
4.0	-2334K	227.00
5.0	-2335K	227.00
6.0	-2336K	227.00
8.0	-2337K	227.00
Set of 6 pieces as above	-2331K	1391.00

Long Parallel Pin Punches with Air Grip

Ideal for driving tight fitting pins out of mechanical assemblies or realigning holes to fit dowel pins. Manufactured from hardened and tempered steel.

Fitted with an air grip handle that absorbs vibration as well as deflecting wayward hammer blows.

Point Diameter (mm)	Overall Length (mm)	Weight each	Order Code KEN-518	Price/1 TB
3	149	53g	-2323K	322.00
4	184	97g	-2324K	446.00
5	200	110g	-2325K	446.00
6	200	117g	-2326K	466.00
8	227	180g	-2328K	477.00

Long Parallel Punch Set

Number of Pieces	Contents	Weight each	Order Code KEN-518	Price/1 TB
5	3, 4, 5, 6 & 8mm	557g	-2330K	2210.00

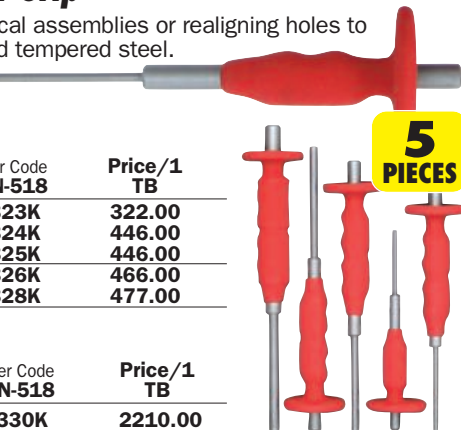

5 PIECES

Nail Punches

Cupped and bevelled precision ground points provide accurate positioning over the nail head for efficient depression. Manufactured from hardened and tempered steel, with a knurled body for extra grip. Conform to BS 3066. (Hardness: heads 42 HRC. Max: points 52 - 58 HRC).

Overall length: 100mm (4").



4 PIECES

Point Diameter (mm)	Order Code KEN-518	Price/1 TB
1.6 (1/16")	-2220K	121.00
2.4 (3/32")	-2230K	121.00
3.2 (1/8")	-2250K	121.00
4.0 (9/32")	-2270K	121.00

Set

Supplied in plastic wallet.

Contents: 1.6, 2.4, 3.2 and 4mm.

Number of Pieces	Order Code KEN-518	Price/1 TB
4	-2300K	459.00

Standard Length Inserted Pin Punches

Manufactured from chrome vanadium steel. Used for punching out pins and dowels.

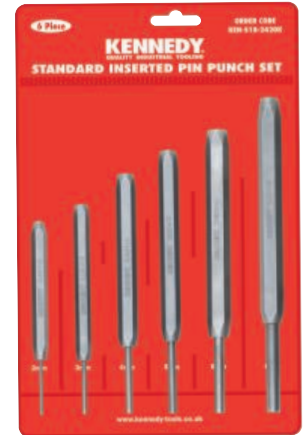

6 PIECES

Size (mm)	Overall Length (mm)	Order Code KEN-518	Price/1 TB
2	115	-2412K	183.00
3	125	-2413K	216.00
4	150	-2414K	233.00
5	165	-2415K	264.00
6	180	-2416K	282.00
8	200	-2418K	322.00

Set

Supplied in plastic wallet.

Contents: 2, 3, 4, 5, 6 and 8mm.

Number of Pieces	Order Code KEN-518	Price/1 TB
6	-2420K	1608.00

Extra Length Inserted Pin Punches

Manufactured from chrome vanadium steel. Used for punching out pins and dowels.

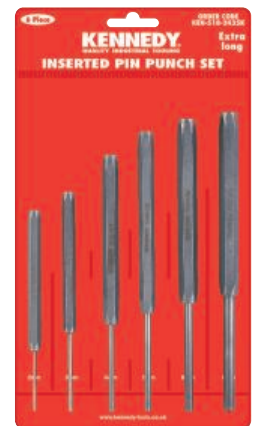

6 PIECES

Size (mm)	Overall Length (mm)	Order Code KEN-518	Price/1 TB
2	143	-2422K	193.00
3	155	-2423K	224.00
4	185	-2424K	239.00
5	202	-2425K	239.00
6	209	-2426K	280.00
8	219	-2428K	293.00
10	230	-2430K	399.00

Set

Supplied in plastic wallet.

Contents: 2, 3, 4, 5, 6 and 8mm.

Number of Pieces	Order Code KEN-518	Price/1 TB
6	-2435K	1797.00

HAND TOOLS

KENNEDY Parallel Pin Punches
QUALITY INDUSTRIAL TOOLING

Ideal for driving tight fitting pins out of mechanical assemblies or realigning holes to fit dowel pins. Manufactured from hardened and tempered steel. With a knurled body for extra grip. Conform to **BS 3066**.



Point Diameter (mm)	Weight each	Order Code KEN-518	Price/1 TB
100mm (4") Overall Length			
1.9 (5/64")	30g	-2125K	99.00
2.4 (3/32")	30g	-2130K	111.00
3.2 (1/8")	30g	-2150K	111.00
3.4 (9/64")	30g	-2155K	113.00
4.0 (5/32")	30g	-2160K	111.00
4.8 (3/16")	40g	-2170K	121.00
5.5 (7/32")	30g	-2180K	121.00
6.3 (1/4")	40g	-2190K	121.00
130mm (5") Overall Length			
7.8 (5/16")	150g	-2192K	132.00
8.8 (11/32")	175g	-2196K	152.00
150mm (6") Overall Length			
4.0 (5/32")	60g	-2350K	141.00
4.8 (3/16")	70g	-2360K	141.00
5.5 (7/32")	175g	-2370K	141.00
6.3 (1/4")	280g	-2380K	141.00

Parallel Pin Punch Sets

Supplied in plastic wallet.

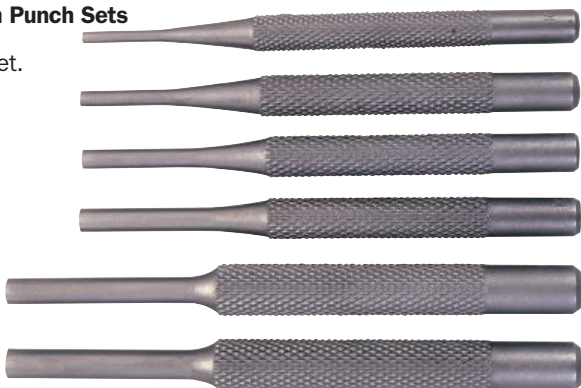

Number of Pieces	Contents (mm)	Weight each	Order Code KEN-518	Price/1 TB
100mm (4") Overall Length				
6	2.4, 3.2, 4.0, 4.8, 5.5 & 6.4	280g	-2200K	626.00
150mm (6") Overall Length				
4	4.0, 4.8, 5.5 & 6.4	585g	-2400K	511.00

Taper Punches

Manufactured from chrome vanadium steel. Used for aligning holes in jigs and fixtures etc.



Point Diameter (mm)	Overall Length (mm)	Weight each	Order Code KEN-518	Price/1 TB
3	210	115g	-1533K	416.00
4	215	160g	-1534K	364.00
5	225	180g	-1535K	361.00
6	240	195g	-1536K	411.00
8	270	380g	-1538K	717.00
10	355	520g	-1540K	886.00
12	355	540g	-1542K	970.00

Taper Punch Set

Contents: 1x 3, 4, 5, and 6mm.



Number of Pieces	Contents	Weight each	Order Code KEN-518	Price/1 TB
4	3, 4, 5 & 6mm	683g	-1550K	1530.00

Straight Shank Hollow Punches

Manufactured from hardened carbon steel. Through body ejection of the punched material makes them ideal for punching clean edged holes in leather, wood, plastics, card and paper.



Cut Diameter (mm)	Overall Length	Order Code KEN-518	Price/1 TB
5 (3/16")	100mm	-1580K	79.00
6 (1/4")	100mm	-1581K	91.00
8 (5/16")	105mm	-1582K	107.00
10 (3/8")	117mm	-1583K	115.00
11 (7/16")	117mm	-1584K	147.00
12 (1/2")	115mm	-1585K	183.00
14 (9/16")	115mm	-1586K	260.00
16 (5/8")	115mm	-1587K	301.00
17 (11/16")	115mm	-1588K	326.00
19 (3/4")	118mm	-1589K	353.00
21 (13/16")	118mm	-1590K	395.00
22 (7/8")	118mm	-1591K	434.00
24 (15/16")	121mm	-1592K	517.00
25 (1")	121mm	-1593K	526.00

Hollow Punch Sets

Supplied in hardwearing PVC pocket wallets with tie fastening.



6 PIECES

Number of Pieces	Contents	Order Code KEN-518	Price/1 TB
6	5mm (3/16") 6mm (1/4") 8mm (5/16") 10mm (3/8") 11mm (7/16") 12mm (1/2")	-1600K	663.00
6	6mm (1/4") 8mm (5/16") 10mm (3/8") 12mm (1/2") 16mm (5/8") 19mm (3/4")	-1650K	1058.00

Reduced Shank Wad Punches

For a variety of soft materials. Can be used for cutting holes and producing clean edged discs from the material being cut.



Cut Diameter (mm)	Overall Length	Order Code KEN-518	Price/1 TB
29 (1 1/8")	175mm	-1594K	1398.00
32 (1 1/4")	175mm	-1595K	1445.00
35 (1 3/8")	205mm	-1596K	1453.00
38 (1 1/2")	205mm	-1597K	1863.00
44 (1 3/4")	210mm	-1598K	2059.00
51 (2")	210mm	-1599K	2163.00

KENNEDY Telescopic Shaft Inspection Mirrors
QUALITY INDUSTRIAL TOOLING



Ball and socket universally positional joint, holds the high grade distortion free mirror at any angle. Chrome plated high polish finish telescopic shafts.

Circular Mirror



*With high power magnet and pocket clip.

Mirror Diameter	Length Closed/Open	Weight each	Order Code KEN-518	Price/1 TB
30mm*	180/480mm	41g	-5380K	102.00

Mirror Diameter	Length Closed/Open	Weight each	Order Code KEN-518	Price/1 TB
50mm	280/420mm	100g	-5420K	122.00

Rectangular Mirror



Mirror Diameter	Length Closed/Open	Weight each	Order Code KEN-518	Price/1 TB
90 x 50mm	370/550mm	127g	-5460K	163.00

Inspection Mirrors

With flexible shafts which can be adjusted into any position. Available as standard or with light attachment. Both models have high grade distortion-free glass mirrors with chrome plated shafts. Inspection mirror with light requires 2x 'AA' batteries and has a swivel head.

Standard

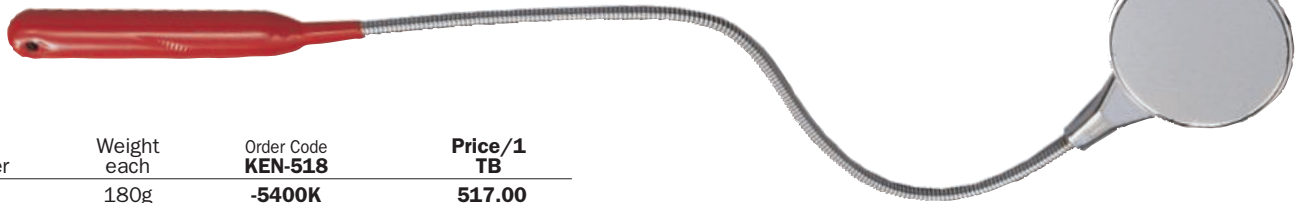

Mirror Diameter	Weight each	Order Code KEN-518	Price/1 TB
50mm	180g	-5400K	517.00

With Light Attachment

Flexible shafts which can be adjusted into any position.



Mirror Diameter	Weight each	Order Code KEN-518	Price/1 TB
50 x 25mm	220g	-5500K	1446.00

Spare Bulb

Description	Weight each	Order Code KEN-567	Price/1 TB
Spare bulb		-6400K	67.00

Hand Magnifiers

Plastic lightweight magnifiers. Used to provide a clear crisp enlarged image. Used for inspection of finished parts, enlarging small text and pictures etc.



Diameter	Magnification	Order Code KEN-518	Price/1 TB
50mm	5x	-6040K	71.00
75mm	4x	-6060K	89.00
100mm	2x	-6080K	135.00

Eye Loupes

Manufactured from shock resistant plastic. Shatterproof lens. Ideal for jewellers, watchmakers, electronics and model makers.



Clear

Magnification Factor	Focal Length (mm)	Weight each	Order Code KEN-518	Price/1 TB
10.0x	31 (1 1/4")	20g	-6000K	135.00

Solid

Magnification Factor	Focal Length (mm)	Weight each	Order Code KEN-518	Price/1 TB
10.0x	31 (1 1/4")	20g	-5290K	121.00
4.0x	63 (2 1/2")	14g	-5300K	63.00
3.5x	75 (3")	10g	-5310K	70.00
3.0x	90 (3 1/2")	10g	-5320K	76.00

Inspection Mirror

Sheet glass mirror recessed into lightweight aluminium housing. Gives clear visibility in concealed areas.

Size: 100 x 100mm.



Size	Order Code KEN-518	Price/1 TB
100mm x 100mm	-5360K	218.00

UP TO 100mm DIAMETER

100mm SQUARE



KENNEDY *Chuck Style Tap Wrenches*
QUALITY INDUSTRIAL TOOLING®

English Type

Used in hand tapping operations, they provide the reach and leverage needed for accurate tapping in tight spaces. Heavy duty ductile steel body with knurled chuck, four equalising jaws to hold the tap true and sliding T-bar which can be used when tapping against a shoulder or other obstructions. Individually boxed.



Square Size (mm)	Length (mm)	Order Code KEN-518	Price/1 TB
Standard Length			
2.0 - 2.8	50	-8860K	259.00
3.0 - 5.0	65	-8880K	415.00
7.0 - 9.4	90	-8900K	590.00
Long Reach			
3.0 - 5.0	165	-8920K	2015.00
7.2 - 9.0	255	-8940K	2544.00

Chuck Type Tap Wrench Set

English Type Contents:

Standard length

2.0 - 2.8,
3.0 - 5.0,
7.0 - 9.4mm.

Extra length

3.0 - 5.0,
7.2 - 9.0mm.

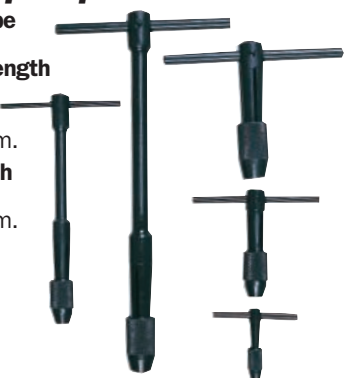

5 PIECES

Number of Pieces	Weight each	Order Code KEN-518	Price/1 TB
5	895g	-9000K	2331.00

Japanese Type

Used in hand tapping operations, they provide the reach and leverage needed for accurate tapping. Heavy duty ductile steel body with knurled chuck, stepped chuck jaws and four point clamping increase the range of tap sizes which can be used in the wrench fitted with a fixed T-bar. Individually boxed.



Square Size (mm)	Length (mm)	Order Code KEN-518	Price/1 TB
Slimline			
2.0 - 4.0	55	-8520K	290.00
Standard Length			
4.0 - 5.0	60	-8550K	389.00
4.0 - 5.5	70	-8580K	435.00
Long Reach			
3.0 - 3.9	100	-8620K	443.00
5.6 - 6.2	120	-8690K	843.00

Engineer's Tap Wrenches

With all steel, hardened and tempered bodies, solid construction, hardened ground jaws and knurled adjustable handles for extra grip. Straight handle design provides greater leverage, especially when using larger diameter taps.

Tap sizes to ISO 529.



Square Size (mm)	Order Code KEN-518	Price/1 TB
2.8 - 5.0	-8320K	480.00
4.0 - 10.0	-8350K	771.00
4.0 - 12.0	-8390K	935.00
5.3 - 17.0	-8470K	2075.00

Tap Wrench Set Contents:
Square size: 2.8 - 5mm and 4.0 - 12mm.

2 PIECES



Number of Pieces	Order Code KEN-518	Price/1 TB
2	-8480K	1299.00

Bar Type Tap Wrenches

Ductile steel body with a knurled locking nut ensuring no loss of grip during use.



Square Size (mm)	Order Code KEN-518	Price/1 TB
1.5 - 5.0	-8800K	262.00
2.0 - 7.2	-8820K	467.00
2.5 - 9.0	-8840K	595.00

Tap Wrench & Diestock Set

Contents

Diestocks: 1" x 13/16", 1" x 1", 1" x 15/16".

Tap wrenches (square size):

1 x 2.8 - 5.0mm and 1 x 4.0 - 10.0mm.



5 PIECES



Number of Pieces	Order Code KEN-518	Price/1 TB
5	-8500K	2375.00

Ratchet Type Tap Wrenches

Manufactured from hardened and tempered steel, with chrome plated high polish finish. Switchable between forward and reverse coupled with the multi-positional sliding T-bar makes this tap wrench ideal for use in confined spaces. Individually boxed.



Square Size (mm)	Length (mm)	Order Code KEN-518	Price/1 TB
3.0 - 6.0	85	-8720K	1270.00
6.0 - 8.0	100	-8750K	2085.00

Replacement Jaws

To Suit	Order Code KEN-567	Price/1 TB
KEN-518-8720K	-6500K	153.00
KEN-518-8750K	-6510K	245.00

Die Stocks

All steel drop forged solid construction for long life with knurled handles for extra grip. Designed to hold a range of different sizes of round split-adjustable dies. The three screw design easily locks die into position and maintains alignment for accurate threading resulting in clean, straight threads.



Outside Diameter	Order Code KEN-518	Price/1 TB
13/16"	-8070K	261.00
1"	-8100K	425.00
1 5/16"	-8130K	518.00
1 1/2"	-8150K	607.00
2"	-8200K	838.00

Die Stock Set Contents:

1 - 13/16" x 150mm,
1 - 1" x 210mm,
1 - 1 5/16" x 280mm.

3 PIECES



Number of Pieces	Order Code KEN-518	Price/1 TB
3	-8210K	972.00

GROUP 518 ENGINEER'S HAND TOOLS

KENNEDY Surface Gauges
QUALITY INDUSTRIAL TOOLING

Used for marking out lines parallel to a true edge or groove, and also to mark the centre of round bars. Machined base, two pillars, a double ended scriber and an adjustable attachment for holding scribes up to 1/4" diameter on to the pillar. The base has a machined V-groove for use on pipes and round bar and two frictionally held pins which are used as a guide when sliding along the true edge or groove. The angle of the pillar can be finely adjusted with the use of a knurled thumb screw. Supplied with two pillars.



Group 330

Base dimensions:
78 x 58mm.

Pillar Height (mm)	Weight each	Order Code KEN-518	Price/1 TB
230 & 305	1.50kg	-4300K	1826.00

Flexible Pick Up Tool

Four prong steel retractable claw. Flexible steel stem with a spring loaded plunger to open and close jaws. Chrome plated and corrosion-resistant. Ideal for recovery of small objects.

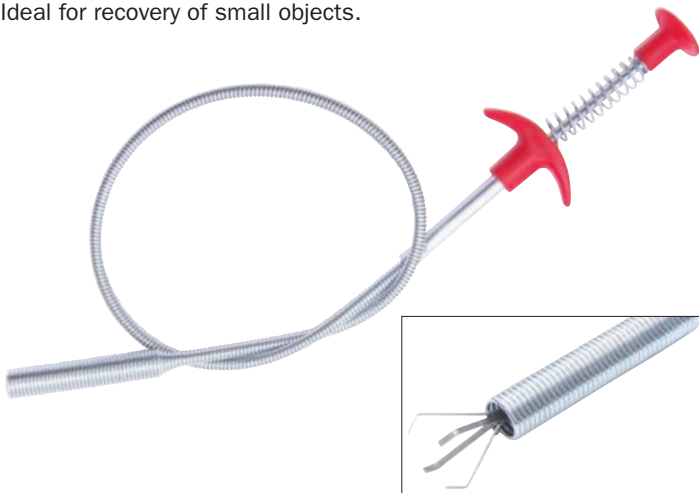

Length	Order Code KEN-518	Price/1 TB
600mm (24")	-4820K	469.00
900mm (36")	-4840K	600.00

Scribers

Used for the marking out of fine lines on metals. Manufactured from hardened and tempered high grade steel with knurled bodies for high grip and precision ground points for accurate marking. Available with a chisel point, pocket type, machinist's standard type, double ended, which are mainly used in conjunction with surface gauges.



Pocket

With steel tip only, also a reversible point to prevent snagging of clothing when clipped into pocket. With knurled bodies for extra grip.

Overall length: 88mm.



Description	Weight each	Order Code KEN-518	Price/1 TB
Pocket Type with Clip	46g	-4330K	511.00
Scriber Point		KEN-567-6200K	80.00

Machinists

One piece single ended for marking out in confined places.

Overall length: 115mm.



Description	Weight each	Order Code KEN-518	Price/1 TB
Machinists Standard	36g	-4350K	85.00

Double Ended

Double ended, ideal for marking out in hard to get places eg. grooves.

Overall length: 180mm.



Description	Weight each	Order Code KEN-518	Price/1 TB
Double Ended	60g	-4370K	155.00

Chisel Point & Scraper

Machinists scriber with scraper. Double ended. Ideal for cleaning surfaces prior to marking out. With chisel point.

Overall length: 180mm.



Description	Weight each	Order Code KEN-518	Price/1 TB
Chisel Point & Scraper	34g	-4360K	140.00

Etching Pen Scriber

For marking, scoring and identification on hard and soft materials including alloy, copper, stainless steel, glass and ceramics.

Overall length: 180mm.



Description	Weight each	Order Code KEN-518	Price/1 TB
T.C.T. For Glass/Tiles	35g	-4200K	322.00
Spare Tip for Etching Pen	9g	-4240K	384.00

Retractable Carbide Tipped Etching Pen

For marking and scribing in hard and soft materials including steel, ceramics, plastics and timber.

Overall length: 180mm.



Description	Weight each	Order Code KEN-518	Price/1 TB
Retractable Etching Pen	35g	-4220K	865.00
Spare Tip for Etching Pen	9g	-4240K	384.00

HAND TOOLS



KENNEDY *Engineer's*
QUALITY INDUSTRIAL TOOLING **Scrapers**

Wooden contoured handles with high grade steel blades, hardened and tempered with extremely keen cutting edges. Scrapers reduce high spots from a surface which has been previously machined or filed.

Three Square

Suitable for tool room and light engineering work. Used on small bearings and bushes and into restricted/tight angles.



Length (mm)	Width (mm)	Weight per 5	Order Code KEN-518	Price/1 TB
100	8	320g	-2440K	318.00
150	10	620g	-2460K	477.00
205	15	1200g	-2480K	1453.00

Flat

For use on flat surfaces and external cylindrical surfaces.



Length (mm)	Width (mm)	Weight per 5	Order Code KEN-518	Price/1 TB
100	16	360g	-2640K	258.00
150	19	650g	-2660K	1453.00
205	23	1300g	-2680K	635.00

Miniature Hook & Pick Set

Includes straight pick, full hook, 90° hook and 45° hook. Ideal for use on cotter pins, keys, 'O' rings, springs and washers. Hardened and tempered chrome vanadium steel shanks with a knurled section for precise grip. Impact resistant square section handles for secure grip even when greasy.

Overall length: 120 - 130mm (4¾" - 5¼").



4 PIECES

Number of Pieces	Order Code KEN-518	Price/1 TB
4	-2900K	535.00

Universal Hook & Pick Set

Designed for use in automotive and engineering applications. Ideal for use in the removal of O-rings, cotter pins, seals, bushes, springs and washers. Impact resistant handles. Presented in sturdy blow moulded plastic case.

Contents; 210mm (8") hook tip, straight tip, 90° tip 135mm (5"), straight tip, hook tip, combination tip, 90° tip.



7 PIECES

Number of Pieces	Order Code KEN-518	Price/1 TB
7	-2920K	1933.00

Half Round

For use on hollow surfaces such as bearing linings and internal cylindrical surfaces.



Length (mm)	Width (mm)	Weight per 5	Order Code KEN-518	Price/1 TB
100	11	330g	-2540K	258.00
150	16	600g	-2560K	270.00
205	16	1000g	-2580K	397.00

3 Piece Set

1 each 100mm three square, half round and 205mm flat.



3 PIECES

Number of Pieces	Weight each	Order Code KEN-518	Price/1 TB
3	350g	-2850K	1197.00

Pin Vices

Manufactured from hardened steel. Ideal for holding drills, small files and wire. The through hole construction of the body allows lengths of wire to be held.



Capacity (mm)	Length (mm)	Order Code KEN-518	Price/1 TB
0.0 - 1.00	83	-1210K	209.00
0.8 - 1.50	85	-1220K	189.00
1.3 - 3.10	90	-1230K	209.00
3.0 - 4.80	100	-1240K	230.00
4 Piece Set - Capacity 0.0 - 4.80			-1200K 886.00

Pin Chucks

For holding small drills in lathes and larger chucks. With three collets.



Range (mm)	Order Code KEN-518	Price/1 TB
0.25 - 2.5	-1260K	1530.00

Toolmaker's Clamps

Hardened and tempered jaws with spring tension clips.

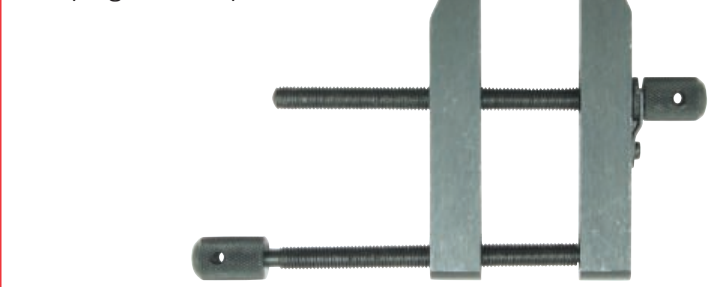

Capacity	Length (mm)	Order Code KEN-518	Price/1 TB
32mm	50	-4400K	446.00
58mm	75	-4410K	628.00
70mm	100	-4420K	628.00
89mm	125	-4430K	774.00

HAND TOOLS

GROUP 522 GARDEN TOOLS



A high quality product that is suitable for use in garden centres, parks, sports areas industrial gardens, farms and for household use where a high quality professional product is required. The products are produced from heat treated steel which is carefully ground. These tools also have steel handles and PVC grips.



Garden Spades

Carbon steel blades. Deep sockets and swan necks for improved strength, polypropylene 'YD' handles and bend resistant shafts.

SBC235

Border
Wooden shaft and plastic handle.
Overall length: 940mm
Blade size: 235 x 140mm.



SBC290

Digging
Wooden shaft and plastic handle.
Overall length: 1010mm.
Blade size: 290 x 180mm.



SBL290

Long Socket
Plastic shaft, soft grip plastic handle and long socket.
Overall length: 1080mm.
Blade size: 290 x 180mm.



CARBON STEEL

Product Number	Type	Weight each	Order Code RTL-522	Price/1 TB
SBC235	Border	1.52kg	-4360K	830.00
SBC290	Digging	1.94kg	-4310K	876.00
SBL290	Digging	2.27kg	-4410K	923.00

Garden Forks

Carbon steel prongs. Deep sockets and swan necks for improved strength, polypropylene 'YD' handles and bend resistant shafts.

FBC235

Border
Wooden shaft and plastic handle.
Overall length: 955mm.
Blade size: 235 x 140mm.



FDC300

Digging
Wooden shaft and plastic handle.
Overall length: 1010mm.
Blade size: 300 x 185mm.



FLC300

Digging Long Socket
Plastic shaft, soft grip plastic handle.
Overall length: 1080mm.
Blade size: 300 x 180mm.



CARBON STEEL

Product Number	Type	Weight each	Order Code RTL-522	Price/1 TB
FBC235	Border	1.35kg	-4350K	830.00
FDC300	Digging	1.83kg	-4300K	830.00
FLC300	Digging	2.36kg	-4400K	923.00

HAND TOOLS

Garden Spades

Polished and ground stainless steel blades with deep sockets and swan neck for improved strength. Bend resistant. Polypropylene 'YD' handles and shafts.

SDS180

Digging
Suitable for general application.
Blade width: 180mm.
Overall length: 1030mm.



SDB150

Border
Suitable for use in confined areas of the garden.
Blade width: 150mm.
Overall length: 910mm.



STAINLESS STEEL

Product Number	Type	Weight each	Order Code RTL-522	Price/1 TB
SDS180	Digging	2.1kg	-2510K	1712.00
SDB150	Border	1.7kg	-2560K	1434.00

Garden Forks

Polished and ground stainless steel prongs with deep sockets and swan neck for improved strength. Bend resistant. Polypropylene 'YD' handles and shafts.

FDS180

Digging
Suitable for general application.
Blade width: 180mm.
Overall length: 1000mm.



FBS140

Border
Suitable for use in confined areas of the garden.
Blade width: 140mm.
Overall length: 910mm.



STAINLESS STEEL

Product Number	Type	Weight each	Order Code RTL-522	Price/1 TB
FDS180	Digging	1.90kg	-2500K	1495.00
FBS140	Border	1.60kg	-2550K	1435.00

Carbon Steel Fork & Trowel

Hammered epoxy coated carbon steel blades. Varnished wooden handles.

Hand trowel: 285 x 87mm.
Weeding fork: 285 x 80mm.



CARBON STEEL

Type	Weight each	Order Code RTL-522	Price/1 TB
Hand Trowel	200g	-4210K	245.00
Weeding Fork	230g	-4200K	245.00

Stainless Steel Fork & Trowel

Stainless steel blades with plastic handles.

Hand trowel: 300 x 81mm.
Weeding fork: 270 x 76mm.
Graduated bulb planter: 300 x 65mm.



STAINLESS STEEL

Type	Weight each	Order Code RTL-522	Price/1 TB
Hand Trowel	255g	-2410K	414.00
Weeding Fork	170g	-2400K	452.00
Bulb Planter	205g	-2420K	376.00
Set of 3 (as above)	825g	-2450K	1029.00



A high quality product that is suitable for use in garden centres, parks, sports areas industrial gardens, farms and for household use where a high quality professional product is required. The products are produced from heat treated steel which is carefully ground. These tools also have steel handles and PVC grips.



Stainless Steel Gardening Tools

240420 Draw Hoe
Blade width: 140mm.
Overall length: 1550mm.

240220 Dutch Hoe
Blade width: 128mm.
Overall length: 1600mm.

240520 Garden Rake
Blade width: 300mm.
Overall length: 1570mm.

STAINLESS STEEL

240120 Edging Knife
Blade width: 215mm.
Overall length: 930mm.

240620 3 Prong Cultivator
Blade width: 90mm.
Overall length: 1620mm.



Product Number	Weight each	Order Code RTL-522	Price/1 TB
240420	1.2kg	-2770K	1267.00
240120	0.9kg	-2700K	615.00
240220	1.5kg	-2750K	1267.00
240520	1.6kg	-2800K	1356.00
240620	1.2kg	-2840K	1378.00

Carbon Steel Gardening Tools

Carbon steel blades, have aluminium shafts and soft grip rubber handles.

341151 Draw Hoe
Blade width: 140mm.
Overall length: 1410mm.

340851 Dutch Hoe
Blade width: 128mm.
Overall length: 1530mm.

341051 Garden Rake
Blade width: 295mm.
Overall length: 1530mm.

CARBON STEEL

340351 Lawn Rake
Blade width: 440mm.
Overall length: 1530mm.



Product Number	Weight each	Order Code RTL-522	Price/1 TB
340851	640g	-4800K	695.00
341151	630g	-4820K	670.00
341051	905g	-4900K	884.00
340351	870g	-4920K	923.00



Premier Gardening Set

10 PIECES

Contents:

Hand trowel, weeding fork and bulb planter, digging spade and fork. Garden rake and dutch hoe both with stainless steel heads, steel handles and PVC grips. Bypass secateurs - maximum cutting diameter 25mm. Heavy duty polythene garden bag with 170ltr capacity. Heavy duty Canadian rigger gloves size 10.

STAINLESS STEEL



Description	Order Code RTL-522	Price/1 TB
10 Piece	-9120K	5562.00

Country Gardening Set

11 PIECES

Contents:

Hand trowel, weeding fork and bulb planter, digging spade and fork. Garden rake, dutch hoe and lawn rake all with carbon steel heads, aluminium handles and soft rubber grips. Bypass secateurs - maximum cutting diameter 25mm. Heavy duty polythene garden bag with 170ltr capacity. Heavy duty Canadian rigger gloves size 10.

CARBON STEEL



Description	Order Code RTL-522	Price/1 TB
11 Piece	-9100K	4635.00

PRODUCTS ARE ONLY AVAILABLE VIA YOUR DISTRIBUTOR

RUTLAND *Quality Gardening Tools* **Bow Saws**

All models feature lever tension handles for rapid blade change and rigid oval section frames. Supplied with clip-on plastic blade protectors to prevent injuries during transportation and storage. Suitable for cutting dry and green wood. Suitable for gardeners, landscapers, builders, farmers etc. Standard duty suitable for occasional use e.g. DIY, gardener etc. Heavy-duty suitable for regular use e.g. professional landscapers etc.

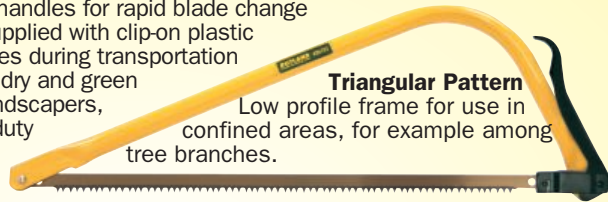

Triangular Pattern
Low profile frame for use in confined areas, for example among tree branches.

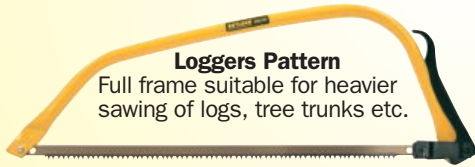

Loggers Pattern
Full frame suitable for heavier sawing of logs, tree trunks etc.

Replacement Blades

Blade Length (mm)	Weight per 10	Order Code RTL-522	Price/1 TB
460 (18")	505g	-7910K	86.00
530 (21")	560g	-7930K	131.00
610 (24")	750g	-7950K	149.00
760 (30")	850g	-7970K	169.00

Type	Duty (Weight)	Blade Length (mm)	Throat Length	Weight each	Order Code RTL-522	Price/1 TB
Triangular	Standard	460 (18")	180mm	480g	-7180K	313.00
Logging	Standard	530 (21")	180mm	480g	-7210K	296.00
Triangular	Heavy	530 (21")	180mm	540g	-7310K	334.00
Logging	Heavy	610 (24")	180mm	700g	-7340K	464.00
Logging	Heavy	760 (30")	230mm	820g	-7400K	504.00

Folding Pruning Saw

Contoured grip with push button locking mechanism.

Overall length: closed 230mm, opened 440mm.



Overall Length	Weight each	Order Code RTL-522	Price/1 TB
440mm	240g	-6600K	567.00

1/4" Mesh Riddle

For bringing soil to a suitable condition, removing large lumps to provide the perfect potting soil, according to size. Made of steel mesh.

Diameter: 360mm.
Depth: 70mm.



Type	Order Code RTL-522	Price/1 TB
1/4" Mesh Riddle	-8400K	328.00

Ratchet Tree Lopper & Telescopic Pole Saw

2.4m telescopic pole. Ratchet cutting mechanism. Pole saw can be used independently or attached to the lopper.

Lopper cutting capacity: 35mm (1 3/8").
Saw blade size: 25 x 350mm (1" x 14").



Overall Length	Order Code RTL-522	Price/1 TB
2.4m	-2120K	2143.00

5-in-1 Secateur Multi-Tool

The 5-in-1 Secateur is a versatile tool ideal for all levels of gardener. The main functions include - root remover, mini saw, secateurs, weeding tool and pruning knife. As well as the five main applications the tool comes equipped with a bi-material grip and stainless steel blades to help prevent rust. With the use of the blade lock, the secateurs can be folded safely into a compact size fitting the pocket pouch included.

Size (H x W x D): 150 x 80 x 18mm.



Overall Length	Weight each	Order Code RTL-522	Price/1 TB
150mm		-2380K	504.00



Bypass Secateurs

Bypass secateurs with a non-clogging telescopic spring and single handed locking mechanism.

Standard Duty

Contoured rubber grip handles.

Maximum cutting diameter: 25mm.

Overall length: 200mm.



Heavy Duty

Textured rubber grip handles.

Overall length: 215mm.



Type	Weight each	Order Code RTL-522	Price/1 TB
Standard	249g	-1600K	358.00
Heavy Duty	297g	-1750K	483.00

Pruning Shears

Spring loaded, with contoured grips and blade locking mechanism.

Overall length: 200mm.

Anvil Action

The anvil secateur is designed for cutting old, hard and deadwood. The anvil supports a wide area of the branch while the sharp narrow upper blade is forced through the wood with only a minimum amount of slicing action.



Bypass Action



Type	Weight each	Order Code RTL-522	Price/1 TB
Anvil Action	227g	-2050K	531.00
Bypass Action	223g	-2100K	531.00

Flora Secateur

Long nose secateurs for delicate pruning jobs. Textured cushioned grip for user comfort.

Maximum cutting diameter: 30mm.



Overall Length	Weight each	Order Code RTL-522	Price/1 TB
180mm	181g	-1550K	578.00

Single Hand Grass Shears

Spring loaded non-stick blades, blade rotation with locking mechanism. For left or right hand use. Blades rotate 360°



Blade length: 200mm.

Blade Rotation	Weight each	Order Code RTL-522	Price/1 TB
360°	297g	-2020K	504.00

RUTLAND Square Mouth Shovels
CONTRACTORS TOOLS

SSC245/SSC190

High-tensile tubular steel construction with 'YD' handle which is designed for heavy industrial and professional use. Shovel head is finished in a tough epoxy powder coating which prevents rusting and reduces soil adhesion.

SSC215

Black finish, heat treated blade and hardwood shaft. Bend resistant. Polypropylene 'YD' handle.

SSC245

Type: open socket.
Handle type: YD polypropylene.
Shaft: metal.
Blade material: carbon steel, epoxy coated.
Blade size (W x H): 245 x 300mm.
Overall length: 965mm.

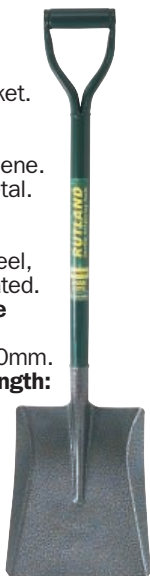

SSC190

Type: open socket
Handle type: YD polypropylene.
Shaft: metal.
Blade material: carbon steel, epoxy coated.
Blade size (W x H): 190 x 300mm.
Overall length: 975mm.



SSC215

Type: open socket.
Handle type: YD polypropylene.
Shaft: hardwood.
Blade material: carbon steel, powder coated, varnished.
Blade size (W x H): 215 x 300mm.
Overall length: 1020mm.



CARBON STEEL

Product Number	Weight each	Order Code RTL-522	Price/1 TB
SSC245	1.95kg	-4500K	1017.00
SSC190	2.13kg	-4510K	902.00
SSC215	1.10kg	-5580K	1081.00

Round Mouth Shovel

SRC230

Black finish, heat treated blade and hardwood shaft. Bend resistant. 'YD' polypropylene handle.

Type: open socket.
Handle type: YD polypropylene.
Shaft: hardwood.
Blade material: carbon steel, powder coated, varnished.
Blade size (W x H): 230 x 300mm.
Overall length: 1010mm.



CARBON STEEL

Product Number	Weight each	Order Code RTL-522	Price/1 TB
SRC230	1.80kg	-5590K	1081.00

Taper Mouth Shovel

STC190

High tensile tubular steel construction with metal 'MYD' handle which is designed for heavy industrial and professional use. Finished in a tough epoxy powder coating which prevents rusting and reduces soil adhesion.

Type: all metal.
Handle type: MYD metal framed.
Shaft: metal.
Blade material: carbon steel, epoxy coated.
Blade width: 190 - 165mm.
Blade height: 280mm.
Overall length: 990mm.



CARBON STEEL

Product Number	Weight each	Order Code RTL-522	Price/1 TB
STC190	1.10kg	-8160K	618.00

RUTLAND Cable Laying, Draining & Grafting Tools
CONTRACTORS TOOLS

High-tensile tubular steel construction designed for heavy industrial and professional use. Shovel head is finished in a tough epoxy powder coating which prevents rusting and reduces soil adhesion.

Cable Laying Shovel

All steel with slightly dished blade and round cutting edges. Designed for clay digging and heavy ground breaking work.

CLC140
Type: all metal.
Handle type: MYD metal framed.
Shaft: metal.
Blade material: carbon steel, epoxy coated.
Blade width: 140 - 115mm.
Blade height: 280mm.
Overall length: 990mm.



Newcastle Drainer

Ideal for digging trenches, pipe, cable and drain channels and post holes.

NCD165
Type: all metal.
Handle type: MYD metal framed.
Shaft: metal.
Blade material: carbon steel, epoxy coated.
Blade width: 165 - 100mm.
Blade height: 400mm.
Overall length: 1115mm.



CARBON STEEL

Product Number	Weight each	Order Code RTL-522	Price/1 TB
CLC140	2.00kg	-8340K	501.00
NCD165	2.20kg	-8500K	595.00
GSC140	3.90kg	-8320K	593.00

Grafting Spade

All steel with a slightly dished head. Ideal for digging post holes in confined spaces.

GSC140
Type: all metal.
Handle type: straight metal.
Shaft: metal.
Blade material: carbon steel, epoxy coated.
Blade width: 140 - 127mm.
Blade height: 280mm.
Overall length: 1650mm.



HAND TOOLS



Pick Axe Handles

Manufactured to **BS 3823**.
Overall length: 950mm (36").

S71440 - Economy

Made from genuine hickory with a waxed finish.

S71410 - Grade 1 Hickory

Handle to fit standard pick axe or mattock eye. Hickory shaft fitted with a plastic grip in the eye of the pick axe or mattock head once fitted.



Product Number	Order Code SSF-522	Price/1 TB
S71440	-6511B	711.00
S71410	-6512C	773.00

Pick Axe Head

S72004

A solid eye navy pick head with chisel and point for the breaking of concrete.

Weight each:
3.18kg (7lb)



Product Number	Order Code SSF-522	Price/1 TB
S72004	-6510A	1366.00

Post Hole Auger

S63124

Provides an easy non-mechanical means of creating holes when erecting fencing posts. When rotated in a clockwise direction the 150mm diameter

thread bores a hole into the soil or clay, with an optional hole depth to suit the length of the post to be secured.

Overall length:
1100mm
Blade size:
340 x 160mm diameter.

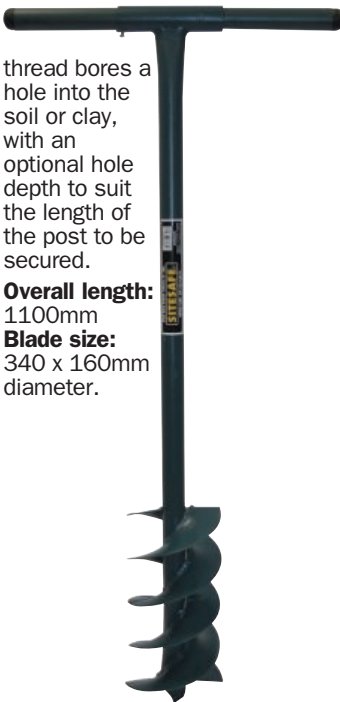

Product Number	Weight each	Order Code SSF-522	Price/1 TB
S63124	3.35kg	-6567C	2388.00

Post Hole Bar - Chisel End

S62424

Steel Post hole digging bar manufactured from high grade heat treated steel bar with one chisel point and one tamper head. The post hole digger has a 60mm mushroom head at one end and a bevelled chisel edge at the other. It is frequently used for digging small holes in earth.

Overall length:
1800mm.

Blade size:
230 x 60mm.



Product Number	Weight each	Order Code SSF-522	Price/1 TB
S62424	8.00kg	-6568D	2812.00

Post Hole Diggers

Post hole diggers have a steel oval mouth shovel blade which are hinged in opposition for easy use and soil removal. A closure stop on the shafts keeps the blades in parallel when driving downward into the ground creating a neat post hole while minimising the need for backfill.



S64424 Scissor Action
Overall length:
1730mm.
Blade size:
360 x 220mm.
Max. opening:
550mm.



S64414 Hinged Action
Overall length:
1500mm.
Blade size:
240 x 135mm.
Max. opening:
150mm.

Product Number	Weight each	Order Code SSF-522	Price/1 TB
S64414	1.15kg	-6565A	2653.00
S64424	6.50kg	-6566B	3449.00

Post Rammer

S65424

All-steel post rammer is the ideal tool for driving posts into the ground. Safer and more accurate than using a sledge or club hammer.

Length: 710mm (28").
Maximum post capacity:
150mm (6") diameter.



Product Number	Weight each	Order Code SSF-522	Price/1 TB
S65424	14.50kg	-6569E	3714.00



Asphalt & Tarmac Rakes

Tubular steel handle, long tang and solid steel painted head with 16 flat teeth for evenly spreading loose stocks of tarmac and asphalt.

S31424 Asphalt Rake
16 Flat Teeth
Head width: 406mm.
Overall length: 1780mm.

S32424 Tarmac Rake
16 Round Teeth
Head width: 406mm.
Overall length: 1780mm.



Product Number	Rake Type	Order Code	Price/1 TB
S31424	Asphalt	-7861B	899.00
S32424	Tarmac	-7862C	1029.00

Floor Scraper

S41411
Used for removing grease and dirt from workshop floors, preparation areas and shopping arcades etc. The steel blade is designed not to damage tiled flooring or laminates and is fitted with fibreglass handles for strength and easy sterilisation.

Overall length: 1480mm.
Blade size: 210 x 100mm.



Spare blades

S41001
Stainless steel to suit floor scrapers. Five hole old type.



Product Number	Weight each	Order Code	Price/1 TB
S41411	1.15kg	-3863A	691.00
S41001	-	-3863D	160.00

Roofing Scraper

S42414
The heavy duty roofing scraper. One-piece solid steel forged blade and wooden handle. The scraper can be re-sharpened with a hand file. Ideal for heavy duty scraping including roofing felt removal, chopping, paint removal and digging or cutting tree roots.

Overall length: 1640mm.
Blade size: 240 x 170mm.



Product Number	Weight each	Order Code	Price/1 TB
S42414	2.60kg	-7120A	1433.00

Earth Rammer

S51424
Square head supplied with tubular steel metal shaft. Used for compacting areas of tarmac or asphalt or for tamping down backfill during the erection of fence posts.

Overall length: 1280mm.
Blade size: 130 x 130 x 25mm.



Product Number	Weight each	Order Code	Price/1 TB
S51424	4.50kg	-3520A	1433.00



HAND TOOLS

RUTLAND Quality Gardening Tools Snow Shovels & Ice Breaker

manufactured from impact resistant ABS plastic with a hard wood shaft and plastic D-grip handle. They incorporate a moulded recess in each shovel pan for easy stacking.

Hardwood Shaft

Small
Overall length: 345 x 310 x 850mm.

Medium
Overall length: 395 x 309 x 1170mm and has a metal wear strip.

Large
Overall length: 465 x 370 x 1200mm and has a metal wear strip.

Unique Stacking



Shovel Type	Order Code	Price/1 TB
Small	-8110K	723.00
Medium	-8120K	723.00
Large	-8130K	723.00

Aluminium Shaft

Lightweight aluminium shaft with a plastic sleeve and has a metal wear strip.

Dimensions (W x D x H): 465 x 370 x 1300mm.

Telescopic
This small shovel is ideal when clearing small surfaces. It is light and strong with a telescopic shaft which is perfect to be used as a car shovel.

Dimensions (W x H): 310 x 700 - 840mm.



Shovel Type	Order Code	Price/1 TB
Telescopic	-8270K	821.00
Aluminium	-8290K	797.00



Suitable for SNOW, SAND, GRAIN ETC.

Ice Breaker

Designed to break up ice and compacted snow, robust steel blade fitted with a wooden shaft and plastic PY handle. Once the compacted snow or ice has been broken up, a snow shovel can be used to move the loosened snow/ice.

Dimensions (W x D x H): 180 x 50 x 1050mm.



Shovel Type	Order Code	Price/1 TB
Ice Breaker	-8310K	372.00

RUTLAND™ Garden Knapsack Sprayers
Quality Gardening Tools

Can be used for left or right handed operation. Spray lance with locking trigger and four adjustable nozzles, that clips onto handle for storage. Pressurising pump handle with grip and storage loop. Pressure release valve. Adjustable webbing shoulder straps.



16ltr capacity
blow-moulded container with filter and fluid level graduations.

20ltr capacity
blow-moulded container with filter and fluid level graduations long reach.



Double conical spray head

Conical spray head

Fan style spray head

4 Hole adjustable spray head

HAND TOOLS

Pressure Sprayer

5ltr capacity blow-moulded container with fluid level graduations. Spray lance with trigger and adjustable nozzle. Pressure release valve. Adjustable webbing shoulder strap.



Capacity	Weight each	Order Code	Price/1 TB
5ltr	1.11kg	-4320K	830.00

Hand Sprayer

High quality hand held sprayer manufactured from ABS plastic which is both shatter-proof and frost-resistant. For use with chemicals around the garden.



Capacity	Weight each	Order Code	Price/1 TB
1.5ltr	360g	-4360K	395.00

Trigger Hand Sprayer

Manufactured from polyethylene, these robust trigger spray dispensers are suitable for many home and garden applications, will dispense various water based detergents, insecticides, soluble plant food, solvents and cleaning agents.



Capacity	Weight each	Order Code	Price/1 TB
500ml		-4900K	109.00
740ml	75g	-4920K	133.00
1000ml		-4940K	170.00

Galvanised Watering Cans

Removeable brass rose head. With reinforced nozzle and side handle.



Capacity	Weight each	Order Code	Price/1 TB
8ltr	1.3kg	-4800K	2059.00

Gardener's Kneeling Pad

Designed for ease of use and user comfort, lightweight and durable with single grab handle. Manufactured from easy to clean water-resistant dense EVA foam, 18mm thick.

Dimensions: 180 x 406 x 18mm.



Material	Weight each	Order Code	Price/1 TB
EVA Foam	121g	-9700K	205.00

RUTLAND *Quality Gardening Tools* **Coil Hose Sets**

These hose coil sets come complete with a seven pattern spray gun, heavy duty snap action connectors and a threaded tap connector. It is light in weight, does not kink or tangle and provides superior waterflow control.

Spray settings:

- Soaker.
- Mist.
- Shower.
- Jet.
- Flat.
- Centre.
- Cone.



3
PIECES

Size	Order Code RTL-523	Price/1 TB
15m	-3940K	1207.00
30m	-3960K	1583.00



Hose Trolley

This large capacity trolley stores up to 60m of 13mm (1/2") hose or 45m of 16mm (5/8") hose. It is easy to assemble – snap and click, needs no tools. It has a sturdy frame with a rust and corrosion-resistant coating.

Hose not included.



Capacity	Order Code RTL-523	Price/1 TB
60m/200ft	-4100K	1453.00

Hose Tidy

This wall mounting bracket provides a tidy solution to the storage of garden hose and fittings. Hose and fittings not supplied.



Type	Order Code RTL-523	Price/1 TB
Hose Tidy	-4090K	156.00

30m Garden Hose Set

30m Standard reinforced garden hose, bore size 13mm. Complete with snap action spray nozzle, female water stop, female fitting and universal tap connector.



5
PIECES

Size	Order Code RTL-523	Price/1 TB
30m	-4120K	1709.00

Garden Hoses

Multi-purpose three layer braided garden hose. Bore size 13mm.



Size	Order Code RTL-523	Price/1 TB
30m	-4020K	1545.00
50m	-4040K	2651.00

Hose Reel Set

This hose reel comes complete with 15m hose and fittings. It is easy to assemble - snap and click, needs no tools and with added hose can store up to 60m of 13mm hose.



8
PIECES

15m

Size	Order Code RTL-523	Price/1 TB
15m	-4140K	2212.00

Hose Reel Set

This hose reel set comes complete with 30m hose and fittings. It is easy to assemble - snap and click, needs no tools.

It can store up to 45m of 16mm hose or 60m of 13mm hose.



8
PIECES

30m

Size	Order Code RTL-523	Price/1 TB
30m	-4080K	3154.00

PRODUCTS ARE ONLY AVAILABLE VIA YOUR DISTRIBUTOR



Spray Nozzle Starter Set

Four piece spray nozzle set with nozzle, water stop hose connector, hose connector and tap adaptor.



Type	Weight each	Order Code	Price/1 TB
Spray Nozzle Starter Set	127g	-4160K	169.00

Adjustable Hose Nozzle

Spray nozzle is adjusted by twisting one part of the body against the other to get the shape/strength of flow required.



Type	Weight each	Order Code	Price/1 TB
Adjustable Hose Nozzle	47g	-4600K	76.00

Brass Outdoor Tap Set

A quick inexpensive, and effective way of fitting an outside tap. Kit includes screws and plugs, self cutting tap, supply hose, garden tap and pipe clips.

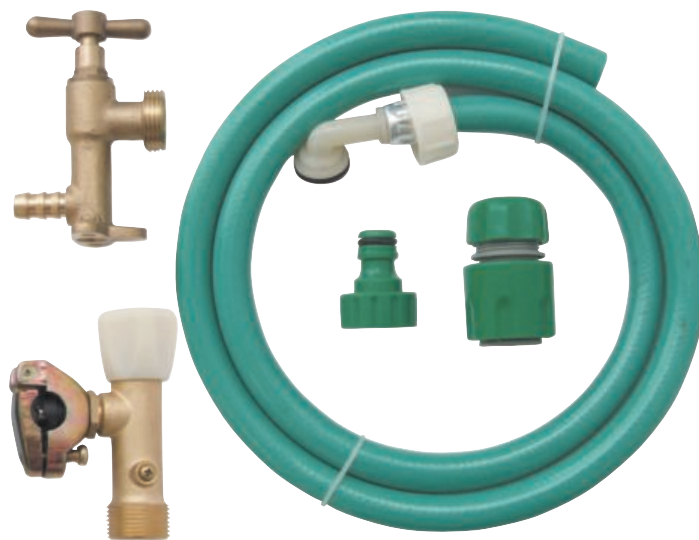

Type	Weight each	Order Code	Price/1 TB
Brass Outdoor Tap Set	760g	-9550K	1339.00

HAND TOOLS

1/2" Water Stop Hose Connector

Water stop valve to cut off supply as soon as the connection is disconnected and is ideal for connecting to implements.



Type	Weight each	Order Code	Price/1 TB
1/2 Water Stop Hose Connector	35g	-4580K	76.00

2 Way Male Snap Action Connector

This fitting is for connecting two hoses with both having female fittings on the end.

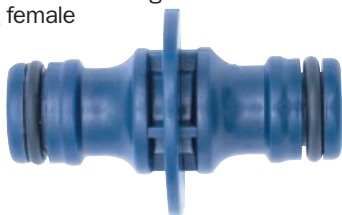

Type	Weight each	Order Code	Price/1 TB
2 Way Male Connector		-4460K	47.00

3 Way Male Snap Action Connector

For splitting one supply hose into two outlets, with all three hoses having female snap action connectors.



Type	Weight each	Order Code	Price/1 TB
3 Way Male Connector	23g	-4470K	63.00

Universal Tap Connector

This male snap action connector can be attached to any tap with either a 1/2" or 3/4" BSP fitting.



Type	Weight each	Order Code	Price/1 TB
Universal Tap Connector	23g	-4530K	59.00

Multi-purpose Tap Connector

This male snap action connector is for connecting a hose onto most modern taps, including mixers.



Type	Weight each	Order Code	Price/1 TB
Multi-Purpose Tap Connector	81g	-4540K	132.00

Hose End Connector

This fitting is for use on the end of the hose which connects to the supply.



Type	Weight each	Order Code	Price/1 TB
Hose End Connector	34g	-4520K	65.00

Clamp-on Tap Connector

This male snap action tap connector has a flexible coupler on the other end which fits most taps and is then tightened onto the tap by twisting the butterfly screw.



Type	Weight each	Order Code	Price/1 TB
Clamp Tap Connector	47g	-4500K	107.00

Large Square Mixer Tap Connector

Fits large or square taps, fits direct to hose. Fits 13mm hose.



Type	Weight each	Order Code	Price/1 TB
Square Mixer Tap	180g	-9560K	438.00

13mm (1/2") Hose Joiner

This fitting is used for either mending or joining hoses.



Type	Weight each	Order Code	Price/1 TB
Hose Joiner	31g	-4480K	50.00



Heavy Duty Spray Gun

6 Pattern Chromed Spray Gun

Heavy duty chrome spray gun, designed to be used for all gardening and general purpose tasks.

Spray settings:

- Soaker.
- Shower.
- Jet.
- Flat.
- Mist.
- Cone.



6
PATTERN

Type	Weight each	Order Code	Price/1 TB
Spray Gun		-9260K	546.00

Brass Spray Gun

This spray gun is easy to control and has a locking trigger, comfort grip and snap action fitting.



Type	Weight each	Order Code	Price/1 TB
Brass Spray Gun	345g	-4220K	421.00

Spray Lance

This spray lance has a pivoting head and telescopic body, making it an invaluable asset when watering hanging baskets, window boxes etc. in any location. The telescopic arm expands from 90cm (36") to 135cm (53").

Spray settings:

- Soaker.
- Shower.
- Centre.
- Jet.
- Flat.
- Mist.
- Cone.

7
PATTERN

EXTENDS TO
135cm



Type	Weight each	Order Code	Price/1 TB
Spray Lance	230g	-4440K	754.00

Spray Gun

This seven pattern spray gun has a comfort grip, locking trigger and snap action connector.

Spray settings:

- Soaker.
- Shower.
- Circle.
- Jet.
- Flat.
- Mist.
- Cone.



7
PATTERN

Type	Weight each	Order Code	Price/1 TB
Spray Gun	170g	-4240K	257.00

Chrome Spray Gun

This heavy duty spray gun has six spray patterns, is easy to control with a comfortable grip, locking trigger and snap action connector.

Spray settings:

- Shower.
- Centre.
- Stream.
- Flat.
- Mist.
- Full.



6
PATTERN

HEAVY DUTY

Type	Weight each	Order Code	Price/1 TB
Chrome Spray Gun	386g	-4230K	438.00

Spray Gun Set

This spray gun set comprises: Six pattern spray gun with locking trigger and snap action connector, female water stop, female fitting and universal tap connector.

Spray settings:

- Shower.
- Centre.
- Stream.
- Flat.
- Mist.
- Full.

4
PIECES



Type	Weight each	Order Code	Price/1 TB
Spray Gun Set	197g	-4200K	358.00

Oscillating Sprinkler

This oscillating sprinkler has a gear drive operation for even, gentle lawn watering. Coverage levers enable easy adjustment to your required oscillation width, giving a coverage of about 200m³ (depends on water pressure, length and bore of hose).

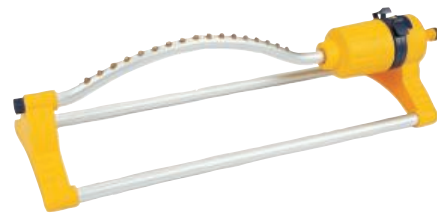

Weight each	Order Code	Price/1 TB
560g	-4400K	772.00

Impulse Sprayer

This sprinkler has a minimal footprint for lawn protection, fully adjustable distance and spray pattern with full or part circle operation and a spray coverage of up to 24m².



Weight each	Order Code	Price/1 TB
490g	-4380K	454.00

HAND TOOLS

GROUP 523 WATER & GARDEN ACCESSORIES

RUTLAND *Quality Gardening Tools* **Lightweight Garden Bag**

170ltr capacity garden bag with two handles. Made from rot-proof woven polyethylene fabric with tear resistant stitching for durability.



Type	Weight each	Order Code	Price/1 TB
Lightweight Garden Bag	220g	-4700K	205.00

Heavy Duty Garden Bag

170ltr capacity garden bag with a unique strengthener around the mouth and three handle design. Tough woven polyethylene fabric with tear resistant stitching for longer usage. UV treated for extra long life and stays rot-proof for years.



Type	Order Code	Price/1 TB
Heavy Duty Garden Bag	-9800K	411.00

Polypropylene Bulk Bag

Used to ship or store a wide variety of bulk materials. Suitable for: building materials, cement, food ingredients, mineral and quarried products, seed, fertiliser, salt, potatoes and garden waste. Safe working load (SWL): 1000kg. Supplied with test certificate.



Size (mm) (W x L x H)	Order Code	Price/1 TB
850 x 850 x 870	-4740K	308.00

Blue Rubble Sacks

Extra strong recycled polythene refuse sacks. Suitable for garden and building site use.

Size (W x L): 460 x 740mm (18" x 29").



Pack Quantity	Order Code	Price/1 TB
7	-4760K	181.00
100	-4770K	2266.00

Gardening Bucket

Flexible

Extremely versatile and virtually indestructible. it can be used for moving soil, garden waste, rubble and various other jobs around a garden or building site.

Diameter: 460mm.



Size	Weight each	Order Code	Price/1 TB
42ltr	200g	-4880K	361.00

SITESAFE *Builder's Buckets*

Flexible

Extremely versatile and virtually indestructible. it can be used for mixing plaster or cement, moving rubble and countless other jobs.



Colour	Size	Order Code	Price/1 TB
Yellow	26ltr	-2980K	308.00
	40ltr	-3000K	411.00
	75ltr	-3040K	823.00
Blue	26ltr	-3080K	411.00
	42ltr	-3100K	411.00



Group 985

HAND TOOLS



Pop-up Gazebo Shelter

NEW



Measuring 3m x 3 x 2.6m when assembled, this pop-up gazebo has a steel frame and waterproof 250g polyester PVC coated cover. Comes complete with guide ropes, pegs, weight bags, wind bar and carrying holdall. Ideal for shelter from the sun or light rain but do not use during extremely windy conditions. Side panels not included - sold separately through order code RTL-984-2520K.

Packed size (W x H x D):
1240 x 205 x 205mm.



Model Number	Weight	Order Code	Price/1 TB
FGS300	15kg	RTL-984	4500.00
		-2500K	

4 Piece Side Panel for Gazebo Shelter

Set of four sides for use with RTL-984-2500K gazebo shelter. Made of 140g polyester with hook and loop fixing straps for easy attachment. Large PVC arched windows on two sides to maximise natural light and zipped doors on other two sides for easy access.



Model Number	Weight	Order Code	Price/1 TB
SP4-FGS	16kg	RTL-984	1750.00
		-2520K	



Galvanised Garden Mesh

Made from high quality hot dip galvanised wire. Ideal for use in decoration, fencing, plant support, cages, aviaries, hutches, coops etc.

Mesh size: 25mm.
Roll size: 0.9 x 10m.



Roll Size	Order Code	Price/1 TB
0.9 x 10m	RTL-523	1019.00
	-5200K	

Weed Control Matting

An organic method of suppressing weeds in your garden or allotment and under decking or patios. The fabric lets water drain through whilst stopping the light that's essential to plant growth.

Standard Duty:
spun bound polypropylene.
50gsm fabric.



Size	Order Code	Price/1 TB
1.0 x 50m	RTL-523	701.00
1.5 x 100m	-5120K	2929.00
Plastic Pegs (Pk of 10)	-5500K	102.00

Heavy Duty:
woven polypropylene
100gsm fabric.

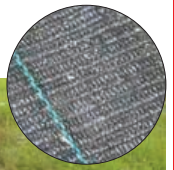

Size	Order Code	Price/1 TB
1.0 x 50m	RTL-523	2292.00
2.0 x 50m	-5020K	4414.00
Plastic Pegs (Pk of 10)	-5500K	102.00

Plastic Garden Fencing

Maintenance free and does not rot or rust, is strong and UV stabilised and is resistant to weed killers and fertilisers. Can be cut to size.

Size: 1.0 x 10m.

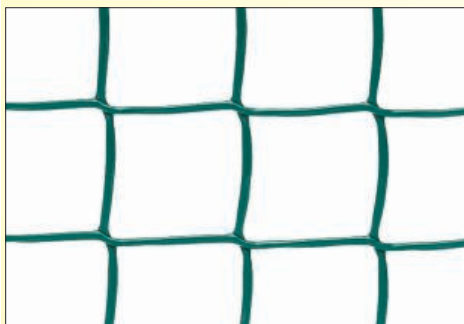

Roll Size	Order Code	Price/1 TB
1.0 x 10m	RTL-523	1803.00
	-5300K	



PRODUCTS ARE ONLY AVAILABLE VIA YOUR DISTRIBUTOR

HAND TOOLS

GROUP 525 HAMMERS

KENNEDY
QUALITY INDUSTRIAL TOOLING

Carpenter's Claw Hammers



Fibreglass Shaft

With textured slip resistant rubber grip. Shaft and grip combine to dampen the impact transmitted through to the user's hand and wrist. Reduces operator fatigue and the risk of RSI (Repetitive Strain Injury). The high strength of the shaft and head bond make the hammer virtually unbreakable.



Head Size	Length (mm)	Weight per 6	Order Code KEN-525	Price/1 TB
450g (16oz)	330	4.80kg	-4460K	674.00
560g (20oz)	330	5.60kg	-4480K	734.00

Hardwood Shaft

With fine grain, forged steel head, hardened and tempered with polished face.



Head Size	Length (mm)	Weight per 6	Order Code KEN-525	Price/1 TB
450g (16oz)	335	4.20kg	-4060K	665.00
560g (20oz)	325	4.80kg	-4100K	706.00

Hickory Shaft

With fine grain, forged steel head, hardened and tempered with polished face.



Head Size	Length (mm)	Weight per 6	Order Code KEN-525	Price/1 TB
450g (16oz)	332	2.70kg	-4160K	626.00
560g (20oz)	350	4.80kg	-4200K	669.00
675g (24oz)	335	5.20kg	-4240K	862.00

Tubular Steel Shaft

With textured slip resistant rubber grip. Dampens the impact transmitted through to the user's hand and wrist.



Head Size	Length (mm)	Weight per 6	Order Code KEN-525	Price/1 TB
450g (16oz)	325	5.30kg	-4360K	636.00
560g (20oz)	325	5.40kg	-4400K	755.00

SENATOR
QUALITY TOOLING

Industrial Claw Hammers



Fibreglass Shaft

Used for general purpose carpentry, particularly for driving and removing nails. With drop forged steel head and hardened and tempered face. Textured rubber grip handle.

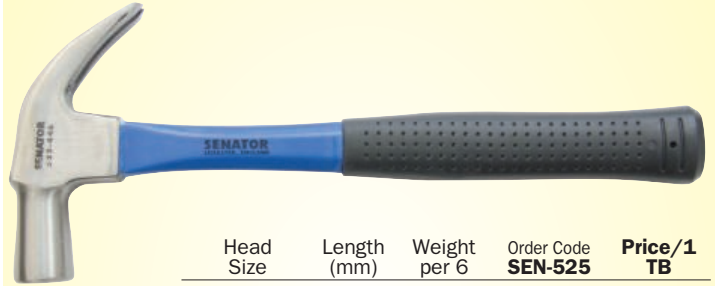

Head Size	Length (mm)	Weight per 6	Order Code SEN-525	Price/1 TB
450g (16oz)	330	4.40kg	-4460K	452.00

Wood Shaft

Used for general purpose carpentry, particularly for driving and removing nails. With drop forged steel head and hardened and tempered faces.



Head Size	Length (mm)	Weight per 6	Order Code SEN-525	Price/1 TB
450g (16oz)	330	4.25kg	-4060K	346.00

Solid Steel Shaft

High strength all steel construction with slip resistant and shock absorbing textured rubber grip for improved user comfort and control.



Head Size	Length (mm)	Weight per 6	Order Code KEN-525	Price/1 TB
450g (16oz)	315	5.00kg	-4420K	1219.00
560g (20oz)	315	8.30kg	-4430K	1500.00

Machinist's Hammers

Machinists hammers suitable for use on metal. Manufactured to European **DIN 1041** standard.



Head Size	Length (mm)	Weight each	Order Code KEN-525	Price/1 TB
500g (17½oz)	320	583g	-7420K	665.00
800g (28oz)	350	984g	-7440K	680.00
1000g (35oz)	360	1227g	-7460K	949.00
1500g (53oz)	380	1850g	-7470K	1075.00
2000g (70oz)	400	2400g	-7480K	1200.00

HAND TOOLS



KENNEDY *Brick Hammers*
QUALITY INDUSTRIAL TOOLING

For setting, dressing and splitting bricks, tiles, concrete blocks, chipping mortar etc.

Standard Pattern Hickory Shaft

With fine grain and forged steel head.



Head Size	Length (mm)	Weight per 6	Order Code KEN-525	Price/1 TB
675g (24oz)	300	5.60kg	-7060K	698.00

Standard Pattern Tubular Steel Shaft

With textured slip resistant rubber grip. Dampens the impact transmitted through to the user's hand and wrist.



Head Size	Length (mm)	Weight per 6	Order Code KEN-525	Price/1 TB
560g (20oz)	290	6.40kg	-7070K	725.00

KENNEDY *Ball Pein Hammers*
QUALITY INDUSTRIAL TOOLING

Fibreglass Shaft

With textured slip resistant rubber grip. Shaft and grip combine to dampen the impact transmitted through to the user's hand and wrist. Reduces operator fatigue and the risk of RSI (Repetitive Strain Injury).



Head Size	Length (mm)	Weight per 6	Order Code KEN-525	Price/1 TB
225g (8oz)	275	3.20kg	-3400K	467.00
340g (12oz)	275	3.20kg	-3430K	514.00
450g (16oz)	350	3.80kg	-3450K	635.00
675g (24oz)	400	6.00kg	-3470K	803.00
900g (32oz)	400	7.20kg	-3500K	883.00

Engineer's Ball Pein Hammers

Ball pein hammers are manufactured from high-grade drop forged steel fully heat-treated. Ideal for use with cold chisels, punches, rivets and for the shaping of metal. They are available with a hardwood, hickory, fibreglass or tubular steel shaft.

Hardwood Shaft

With fine grain, forged steel head, hardened and tempered with polished faces.

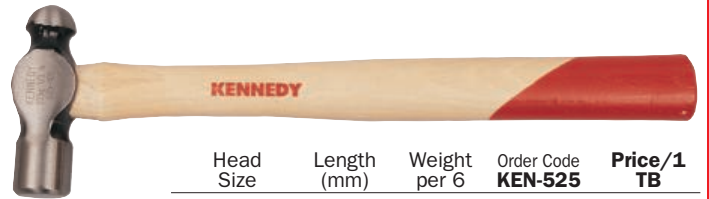

Head Size	Length (mm)	Weight per 6	Order Code KEN-525	Price/1 TB
113g (4oz)	255	1.00kg	-1020K	369.00
225g (8oz)	295	2.20kg	-1050K	415.00
340g (12oz)	295	2.90kg	-1070K	527.00
450g (16oz)	350	3.80kg	-1100K	573.00
675g (24oz)	395	5.90kg	-1150K	604.00
900g (32oz)	400	7.20kg	-1200K	666.00
1125g (40oz)	415	6.00kg	-1250K	942.00
1350g (48oz)	400	10.70kg	-1300K	971.00

Hickory Shaft

With fine grain, forged steel head, hardened and tempered with polished faces.

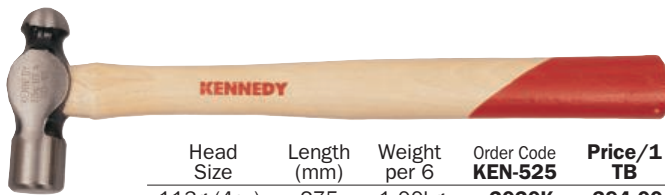

Head Size	Length (mm)	Weight per 6	Order Code KEN-525	Price/1 TB
113g (4oz)	275	1.00kg	-2020K	394.00
225g (8oz)	295	2.20kg	-2050K	428.00
340g (12oz)	295	3.00kg	-2070K	541.00
450g (16oz)	350	3.80kg	-2100K	573.00
675g (24oz)	385	6.10kg	-2150K	686.00
900g (32oz)	395	7.20kg	-2200K	755.00
1125g (40oz)	400	8.30kg	-2250K	949.00

Tubular Steel Shaft

With textured slip resistant rubber grip. Dampens the impact transmitted through to the user's hand and wrist.



Head Size	Length (mm)	Weight per 6	Order Code KEN-525	Price/1 TB
450g (16oz)	320	4.60kg	-3650K	769.00

SENATOR *Engineer's Ball Pein Hammers*
QUALITY TOOLING

Hickory Shaft

Manufactured from finest quality drop forged steel, hardened and tempered with ground and polished faces.

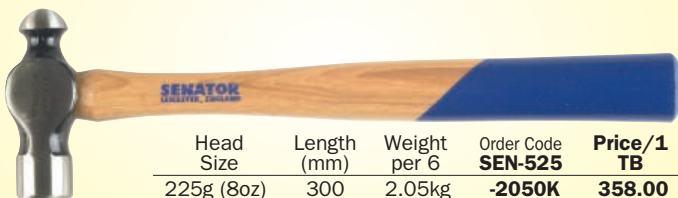

Head Size	Length (mm)	Weight per 6	Order Code SEN-525	Price/1 TB
225g (8oz)	300	2.05kg	-2050K	358.00
450g (16oz)	350	3.55kg	-2100K	465.00
675g (24oz)	400	6.00kg	-2150K	563.00
900g (32oz)	400	6.75kg	-2200K	590.00

Pin Ball Pein Hammer

Hickory Shaft

With fine grain, forged steel head, hardened and tempered with polished faces. For light applications.



Head Size	Length (mm)	Weight per 6	Order Code KEN-525	Price/1 TB
113g (4oz)	320	5.90kg	-8050K	487.00

HAND TOOLS

GROUP 525 HAMMERS

KENNEDY Cross Pein Hammers
QUALITY INDUSTRIAL TOOLING

Cross pein hammers are traditionally used by joiners and fitters. Cross pein can be used for setting pins and nails prior to 'driving home' with the flat faced pein.

Hickory Shaft

Hardened and ground forged steel head with polished striking face securely fixed to a close grain hickory shaft. Shaped to fit comfortably in the hand. Tapered head, suitable for use with small pins helps reduce over-strike.



Head Size	Length (mm)	Weight per 12	Order Code KEN-525	Price/1 TB
100g (3½oz)	320	2.40kg	-8030K	541.00

'Pin' Hardwood Shaft

Hardened and ground forged steel head with polished striking face securely fixed to a close grain hardwood shaft. Shaped to fit comfortably in the hand. Tapered head, suitable for use with small pins helps reduce over-strike.



Head Size	Length (mm)	Weight per 12	Order Code KEN-525	Price/1 TB
100g (3½oz)	325	3.20kg	-8040K	434.00

Warrington Hardwood Shaft

Close grained hardwood shaft shaped to comfortably fit in the hand. Forged steel head with ground and polished striking face.



Head Size	Length (mm)	Weight per 6	Order Code KEN-525	Price/1 TB
225g (8oz)	280	1.30kg	-8080K	469.00
283g (10oz)	290	2.50kg	-8100K	434.00
340g (12oz)	300	3.00kg	-8120K	477.00
397g (14oz)	325	3.50kg	-8140K	446.00
450g (16oz)	330	4.10kg	-8160K	926.00

Magnetic Tack Hammers

Hickory Shaft

For holding and driving tacks.



Hammer Type	Head Size	Length (mm)	Weight per 12	Order Code KEN-525	Price/1 TB
Tack	142g (5oz)	265	3.60kg	-7500K	450.00
Upholsterer	198g (7oz)	270	4.00kg	-7550K	464.00

Welder's Chipping Hammers

Scaling and chipping hammers. For boiler scaling, weld dressing etc.



Hardwood Shaft

Manufactured from tempered and hardened steel, chisel and point striking faces with close grain hardwood handle.

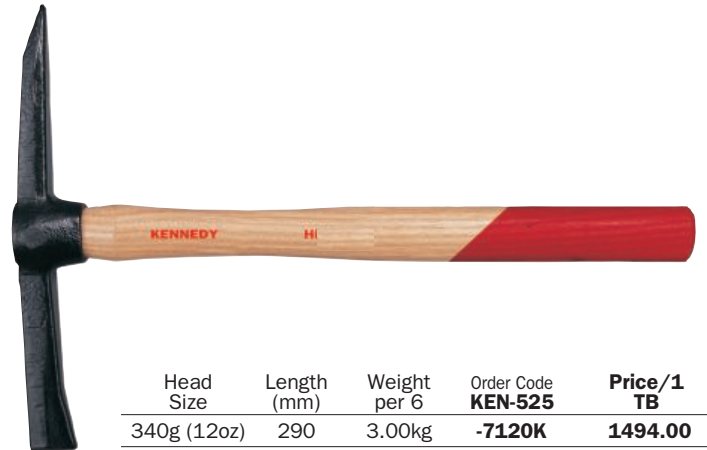

Head Size	Length (mm)	Weight per 6	Order Code KEN-525	Price/1 TB
340g (12oz)	290	3.00kg	-7120K	1494.00

Spring Steel Shaft

Hardened and tempered steel head chisel edge and point striking faces with epoxy coating. Spring steel impact absorbing handle for user comfort.

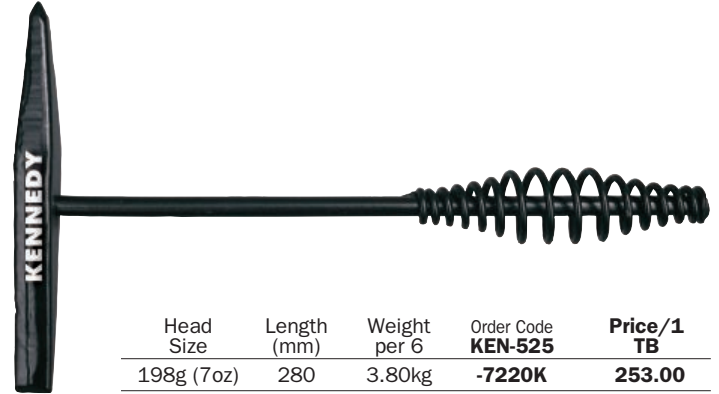

Head Size	Length (mm)	Weight per 6	Order Code KEN-525	Price/1 TB
198g (7oz)	280	3.80kg	-7220K	253.00

Scutch Hammer

Hickory Shaft

Double bit type. Suitable for dressing brick and stone work prior to rendering. Replaceable plain and comb style bits supplied separately. With fine grain, forged steel head, hardened and tempered with polished faces.

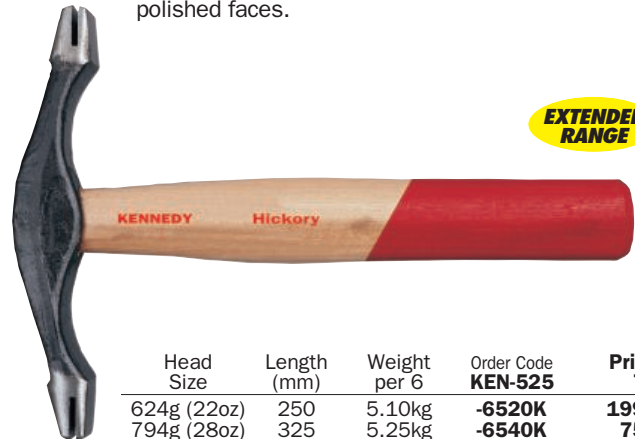

EXTENDED RANGE

Head Size	Length (mm)	Weight per 6	Order Code KEN-525	Price/1 TB
624g (22oz)	250	5.10kg	-6520K	1999.00
794g (28oz)	325	5.25kg	-6540K	750.00

Detachable Bits

For scutch chisels and hammers.

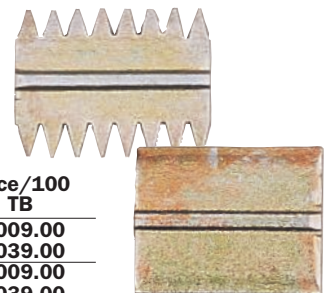

Comb Type	Width (mm)	Order Code KEN-505	Price/100 TB
Wide/Coarse	25	-9130K	2099.00
	38	-9140K	3039.00
Plain/Drove	25	-9230K	2099.00
	38	-9240K	3039.00



KENNEDY Club Hammers
QUALITY INDUSTRIAL TOOLING

Club (or lump) hammers are fully forged and heat treated with flat face and chamfered edge for use with cold chisels, brick bolsters, star drills and masonry nails.

Fibreglass Shaft

With textured slip resistant rubber grip. Shaft and grip combine to dampen the impact transmitted through to the user's hand and wrist. Reduces operator fatigue and the risk of repetitive strain injury (RSI).



Head Size	Length (mm)	Weight each	Order Code KEN-525	Price/1 TB
1125g (40oz)	270	2.75kg	-5720K	879.00
1350g (48oz)	265	3.15kg	-5740K	936.00
1800g (64oz)	270	4.00kg	-5760K	1093.00

Hickory Shaft

With fine grain, forged steel head, hardened and tempered with polished faces.



Head Size	Length (mm)	Weight each	Order Code KEN-525	Price/1 TB
1125g (40oz)	330	2.40kg	-5250K	879.00
1350g (48oz)	265	2.75kg	-5300K	917.00
1800g (64oz)	265	3.60kg	-5400K	1044.00

Sledge Hammers

Double faced sledge hammers are fully forged and heat-treated. Ideal for use on spikes, stakes, cold chisels and hardened nails. They are available with a hickory or fibreglass shaft.

Fibreglass Shaft (BS 876 Sledge Hammers)

Dampens the impact transmitted to the user's hand and wrist. Tested to the requirements of **BS 876: 1981** (head stamped **BS 876**).



Head Size	Length (mm)	Weight each	Order Code KEN-525	Price/1 TB
1814g (64oz)	350	2.20kg	-5840K	2903.00
3175g (112oz)	900	3.80kg	-6180K	3389.00
4536g (160oz)	910	5.30kg	-6190K	3982.00
6350g (224oz)	910	7.40kg	-6200K	4254.00

Hickory Shaft

With fine grain, forged steel head, hardened and tempered with polished faces.



Head Size	Length (mm)	Weight each	Order Code KEN-525	Price/1 TB
1814g (64oz)	350	2.10kg	-5940K	1645.00
3175g (112oz)	900	3.80kg	-6070K	2250.00
4536g (160oz)	900	5.40kg	-6100K	2865.00
6350g (224oz)	900	7.30kg	-6140K	3147.00

HAND TOOLS

KENNEDY Camp Axe
QUALITY INDUSTRIAL TOOLING

One piece solid steel shaft with rubber grip. Supplied with protective head cover.

Overall length: 345mm.



Head Size	Weight per 6	Order Code KEN-525	Price/1 TB
566g (20oz)	6.20kg	-9090K	1822.00

Chopping Axe

Heat treated tubular steel shaft with rubber grip. Drop forged polished and lacquered head. Supplied with protective head cover. Belt slits in head cover offer hands free storage whilst in transit.

Overall length: 335mm.



Head Size	Weight per 6	Order Code KEN-525	Price/1 TB
453g (16oz)	5.40kg	-9110K	917.00

Riggers Hatchet

One piece solid steel shaft with rubber grip. With a sharp cutting edge and chequered face.

Overall length: 430mm.

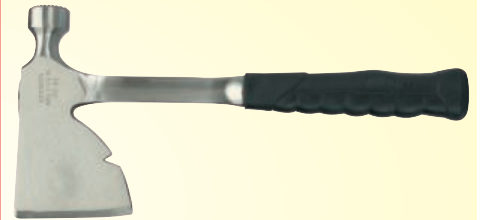

Head Size	Weight per 6	Order Code KEN-525	Price/1 TB
795g (28oz)	7.20kg	-9140K	1287.00

Felling Axe

Suitable for felling small trees, chopping off branches and splitting logs. High quality tool steel blade, polished and lacquered. Finely sanded hickory handle, shaped for maximum user comfort. Part painted head and handle for durability. 900mm hickory shaft. 2½" x ¾" eye.

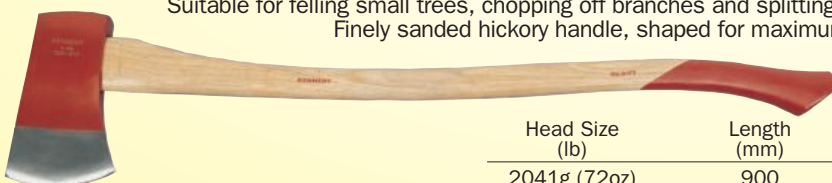

Head Size (lb)	Length (mm)	Weight per 6	Order Code KEN-525	Price/1 TB
2041g (72oz)	900	23.0kg	-9130K	2207.00

PRODUCTS ARE ONLY AVAILABLE VIA YOUR DISTRIBUTOR

GROUP 525 HAMMERS

KENNEDY Bumping Hammers
QUALITY INDUSTRIAL TOOLING

Highly polished striking heads and cheeks. One square and one round face. The most popular general purpose panel beating hammer. Hickory shaft. Manufactured to **BS 4114**.

Flat Faced

For straightening thicker gauge metals where a reasonable striking force is needed.

Length: 325mm.

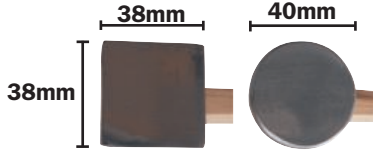

Head Size	Weight Per 6	Order Code KEN-525	Price/1 TB
340g (12oz)	2.60kg	-7250K	1075.00

Crown Faced

As above but with crowned face.

Length: 325mm.

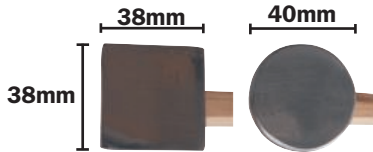

Head Size	Weight Per 6	Order Code KEN-525	Price/1 TB
340g (12oz)	2.60kg	-7260K	1207.00

Shrinking Hammers

Highly polished striking heads and cheeks. One flat round face and one milled, serrated square face. Hickory shaft. Manufactured to **BS 4114**. Specially designed for panel beating on slightly stretched areas of metal. The cross milled face forces small amounts of metal into the spaces created.

Sizes: 325mm (except -7300K = 345mm).

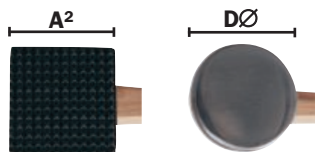

Head Size	L (mm)	A² x Dia (mm)	Order Code KEN-525	Price/1 TB
320g (11 ¹ / ₃ oz)	100	37 x 40	-7280K	1029.00
390g (13 ³ / ₄ oz)	95	35 x 40	-7290K	1082.00
450g (16oz)	110	40 x 48	-7300K	1133.00

Finishing Picks

Highly polished striking heads and cheeks. With crowned faces. Will remove low spots when metal finishing. Hardwood shaft and finishing beater. Manufactured to **BS 4114**.

Curved Pein Panel Beater

Medium weight for general use where access is difficult.

Length: 325mm.



Head Size	Weight Per 6	Order Code KEN-525	Price/1 TB
284g (10oz)	2.70kg	-7320K	969.00

Straight Pein and Finishing Panel Beater

Medium weight for general use.

Length: 325mm.



Head Size	Weight Per 6	Order Code KEN-525	Price/1 TB
284g (10oz)	2.70kg	-7330K	1287.00

Round Pick and Finishing Panel Beater

Medium weight with crowned face designed to remove high spots. Hickory shaft.

Length: 325mm.



Head Size	Weight Per 6	Order Code KEN-525	Price/1 TB
255g (9oz)	2.40kg	-7340K	921.00

Reverse Curve Finishing Hammer

Highly polished striking heads and cheeks. The high crowned radius faces have a convex surface suitable for work on concave and recessed panels. The short head is ideal for use in confined areas. Hardwood shaft.

Length: 325mm.



Head Size	Weight Per 6	Order Code KEN-525	Price/1 TB
320g (11 ¹ / ₃ oz)	2.30kg	-7310K	969.00



KENNEDY Bossing Mallets
QUALITY INDUSTRIAL TOOLING

Delivers the necessary blow to shape sheet metal and still made to the exacting standards.



Head Dia. (mm)	Weight each	Order Code KEN-549	Price/1 TB
40 (1 ¹ / ₂ "	130g	-2500K	1115.00
50 (2"	370g	-2520K	1029.00
75 (3"	452g	-2560K	1236.00

THOR HAMMER Plastic Mallets

Ultra high molecular weight polythene mallet heads, suitable for high impact applications. With solid wooden shafts.

Tinmens - Cylindrical



Bossing - Pear Shaped



Product Number	Face Dia. (mm)	Weight each	Order Code THO-527	Price/1 TB
Tinmens - Cylindrical				
23-8112	40	180g	-0370A	711.00
23-8114	45	240g	-0371C	926.00
23-8116	50	325g	-0372E	1029.00
23-8119	60	490g	-0373G	1391.00
23-8122	70	650g	-0374J	1545.00
23-8126	80	950g	-0375L	1906.00
Bossing - Pear Shaped				
23-8898SP	50	200g	-0378S	1494.00
23-8899SP	60	290g	-0379V	1597.00
23-8900SP	70	420g	-0380B	1803.00

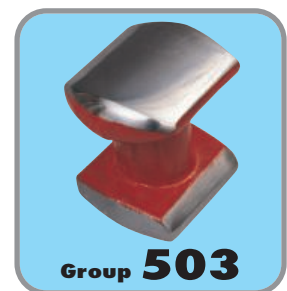

HAND TOOLS

THOR HAMMER Rubber Mallets



Standard: All purpose mallet used widely for automotive, industrial, DIY and camping etc.

Product Code	Face (mm)	Length (mm)	Weight each	Order Code THO-527	Price/1 TB
61-951	40	265	150g	-0430N	308.00
61-952	54	315	325g	-0431P	411.00
61-953	64	340	525g	-0432Q	520.00
61-954	74	380	600g	-0433R	684.00
61-957	90	380	900g	-0434S	902.00



White: Will not leave marks on work surfaces. Suitable for woodworking, window frame manufacturers, shop fitters and car trim etc.

Product Code	Face (mm)	Length (mm)	Weight each	Order Code THO-527	Price/1 TB
61-952W	54	315	300g	-0446E	464.00
61-953W	64	315	300g	-0448G	593.00
61-954W	74	380	725g	-0450J	823.00
61-957W	90	380	1125g	-0452L	1092.00

Solid Copper Mallet

99.9% pure copper. These mallets provide a firm positive blow without the risk of damage to expensive components.

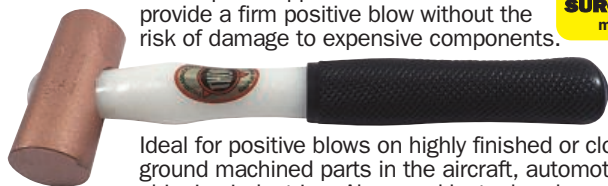

Ideal for positive blows on highly finished or closely ground machined parts in the aircraft, automotive or shipping industries. Also used by tool and gauge makers.

Product Code	Face (mm)	Length (mm)	Weight each	Order Code THO-527	Price/1 TB
Tack	50	290	930g	-0479L	2077.00

Due to the fluctuating price of **COPPER**, SURCHARGES may apply

Rawhide Mallets

Rawhide head with solid wooden handle.

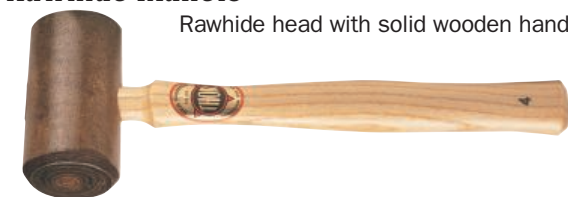

Product Code	Face (mm)	Length (mm)	Weight each	Order Code THO-527	Price/1 TB
02-108	25	250	60g	-0130G	823.00
02-110	32	250	115g	-0131H	943.00
02-112	38	280	170g	-0132J	1288.00
02-114	44	305	225g	-0133K	1391.00
02-116	50	305	340g	-0134L	1803.00
02-120	63	340	570g	-0135M	2575.00
02-122	70	340	680g	-0136N	2833.00

Laminated Compressed Wood Mallets

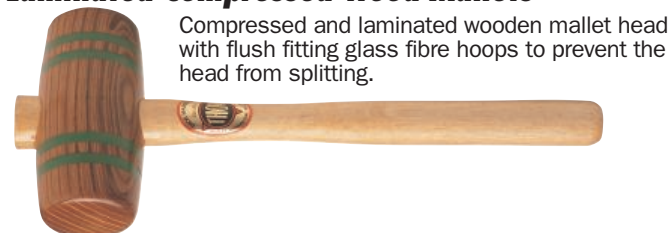

Compressed and laminated wooden mallet head with flush fitting glass fibre hoops to prevent the head from splitting.

Model Code	Face (mm)	Length (mm)	Weight each	Order Code THO-527	Price/1 TB
62-8050	48	290	300g	-0341B	2163.00
62-8060	58	320	525g	-0342C	2524.00
62-8070	67	360	750g	-0343D	2833.00

KENNEDY Rubber Mallets

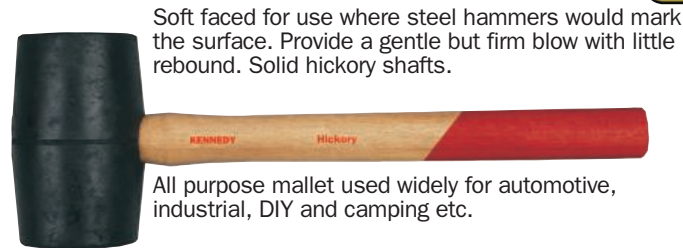

Soft faced for use where steel hammers would mark the surface. Provide a gentle but firm blow with little rebound. Solid hickory shafts.

All purpose mallet used widely for automotive, industrial, DIY and camping etc.

Face (mm)	Head Size	Length (mm)	Weight Per 6	Order Code KEN-525	Price/1 TB
42	225g (8oz)	280	1.80kg	-9120K	133.00
55	450g (16oz)	315	3.30kg	-9160K	177.00
65	675g (24oz)	300	4.80kg	-9180K	230.00

SENATOR Rubber Mallet

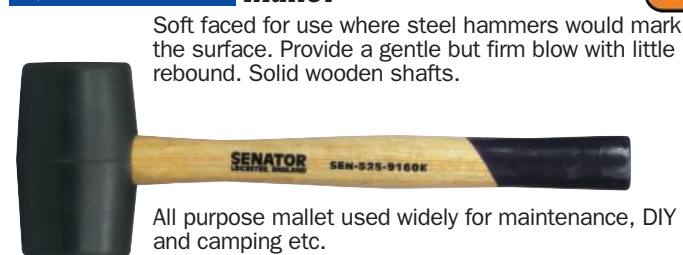

Soft faced for use where steel hammers would mark the surface. Provide a gentle but firm blow with little rebound. Solid wooden shafts.

All purpose mallet used widely for maintenance, DIY and camping etc.

Face (mm)	Head Size	Length (mm)	Weight Per 6	Order Code SEN-525	Price/1 TB
55	450g (16oz)	300	3.10kg	-9160K	200.00

DeadBlow™ Hammer



Polyurethane. Inside hammer head are steel pellets which impact a split second after the hammer face, reducing rebound.

Face (mm)	Head Size	Length (mm)	Weight Per 6	Order Code SEN-525	Price/1 TB
50	794g (28oz)	320	4.75kg	-9460K	1103.00

SAFEBLOWER SafeBlower™ Hammers

With solid steel bar shaft and hollow head. Inside the polyurethane moulded hammer head are thousands of steel pellets which impact a split second after the hammer face, reducing rebound whilst also adding to the force of the blow.

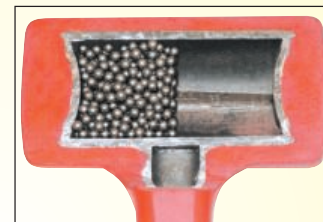

Face (mm)	Head Size	Length (mm)	Weight each	Order Code KEN-525	Price/1 TB
33	397g (14oz)	280	0.45kg	-9420K	901.00
43	560g (20oz)	300	0.60kg	-9440K	1056.00
48	794g (28oz)	350	0.80kg	-9460K	1323.00
53	1077g (38oz)	350	1.00kg	-9480K	1493.00
68	1276g (45oz)	375	1.25kg	-9500K	1827.00

2 Piece SafeBlower Set

Number of Pieces	Contents	Weight each	Order Code KEN-525	Price/1 TB
2	14 & 28oz	1.25kg	-9550K	1955.00

GROUP 527 HAMMERS - INSERTED FACE

KENNEDY PROFESSIONAL Nylon Faced Hammers

Hard nylon faced hammer with two screw-on all purpose striking faces for light and heavy duty applications. Chrome plated head with a fully moulded polypropylene shaft with soft feel dual material grip. **Overall length: 305mm.**



Face (mm)	Weight each	Order Code KEN-527	Price/1 TB
32	435g	-3040K	793.00
38	627g	-3060K	1075.00
44	800g	-3080K	1326.00
50	950g	-3100K	1577.00

Replaceable Hard Nylon Hammer Faces

Replaceable hard nylon face with thread. All purpose face suitable light and heavy duty applications. To suit nylon faced hammers and safeblow hammers.



Face (mm)	Weight each	Order Code KEN-529	Price/1 TB
32	15g	-3040K	83.00
38	20g	-3060K	105.00
44	40g	-3080K	126.00
50	50g	-3100K	126.00

THOR HAMMER Thorex Nylon Faced Hammers

Chrome plated head with two screw on nylon striking faces.



Product Number	Face (mm)	Length (mm)	Weight each	Order Code THO-527	Price/1 TB
Wooden Handle					
12-708N	25	250	250g	-0320N	797.00
12-710N	32	270	450g	-0321P	903.00
12-712N	38	270	675g	-0322Q	1029.00
12-714N	44	310	900g	-0323R	1288.00
12-716N	50	325	1250g	-0324S	1700.00
12-720N	63	355	1700g	-0325T	2009.00
Plastic Handle					
11-710	32	300	450g	-0203D	917.00
11-712	38	310	675g	-0205F	1029.00
11-714	44	310	900g	-0207H	1327.00
11-716	50	350	1020g	-0208S	1545.00

Thorex Plastic Faced Hammers

Chrome plated head with two screw on medium hardness plastic striking faces. Polyurethane shaft with non-slip textured PVC grip. Available with a nylon handle with a non-slip textured PVC grip or a wooden handle.



Product Number	Face (mm)	Length (mm)	Weight each	Order Code THO-527	Price/1 TB
Wooden Handle					
07-406	19	250	150g	-0200A	670.00
07-408	25	250	250g	-0201B	720.00
Plastic Handle					
07-410	32	280	450g	-0202C	823.00
07-412	38	290	675g	-0204E	926.00
07-414	44	305	900g	-0206G	1236.00
07-416	50	305	1250g	-0208J	1380.00

Spare Striking Faces

For the Thorex nylon faced hammers. Easy to change, simply screw in. The striking faces are colour coded to allow easy identification of material type and hardness.

Orange: polyurethane plastic medium hardness shore D45-55.
Yellow - extra hard: ABS Rockwell R103: extra hard faces for specialist applications only e.g. setting copper armatures.



Product Number	Face (mm)	Weight Per 10	Order Code THO-529	Price/1 TB
Orange - Medium Hard				
73-406PF	19	40g	-0215K	67.00
73-408PF	25	70g	-0217M	83.00
73-410PF	32	168g	-0220Q	93.00
73-412PF	38	265g	-0223T	129.00
73-414PF	44	405g	-0226X	140.00
73-416PF	50	572g	-0230A	181.00
Yellow - Extra Hard				
73-408AF	25	72g	-0216L	90.00
73-410AF	32	170g	-0219P	102.00

HAMMERS - INSERTED FACE

THOR HAMMER Thorace Dead Blow Hammers

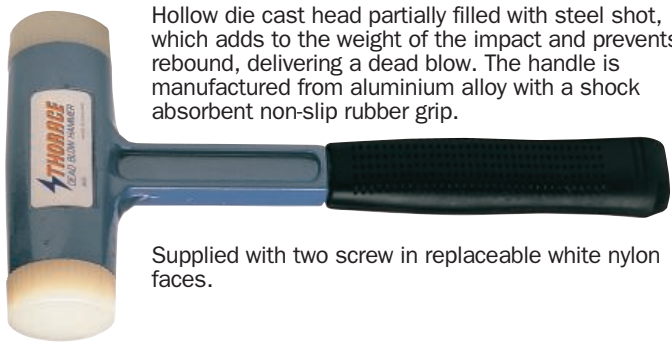

Hollow die cast head partially filled with steel shot, which adds to the weight of the impact and prevents rebound, delivering a dead blow. The handle is manufactured from aluminium alloy with a shock absorbent non-slip rubber grip.

Supplied with two screw in replaceable white nylon faces.

Product Number	Face (mm)	Length (mm)	Weight each	Order Code THO-527	Price/1 TB
20-1010	32	275	525g	-0455M	1494.00
20-1212	38	305	750g	-0456N	1700.00
20-1414	44	310	950g	-0457P	1906.00
20-1616	50	325	1250g	-0458Q	2266.00
20-2020	63	370	2000g	-0459R	3348.00

Spare Striking Faces

For the Thorex nylon faced and Thorace hammers. Easy to change, simply screw in. The striking faces are colour coded to allow easy identification of material type and hardness.

Grey: Soft PVC shore A63-73. Will not mark finished surfaces.

Red: Polyurethane medium plastic shore D45-55. For light hammering applications.

Brown: Tough polyurethane shore D58-62. Abrasive resistant suitable for striking sharp surfaces.

White: Hard nylon shore D61-65. All purpose face suitable for light and heavy duty applications.

Yellow: ABS extra hard rockwell R103. For specialist applications.



Product Number	Face (mm)	Weight per 10	Order Code THO-529	Price/1 TB
Grey - Soft PVC				
76-708VF	25	195g	-0380M	102.00
76-710VF	32	246g	-0381N	129.00
76-712VF	38	352g	-0382P	150.00
76-714VF	44	540g	-0383Q	181.00
76-716VF	50	734g	-0384R	212.00
Red - Medium Plastic				
76-708PF	25	128g	-0340K	93.00
76-710PF	32	165g	-0340M	98.00
76-712PF	38	244g	-0340P	129.00
76-714PF	44	368g	-0340R	150.00
76-716PF	50	498g	-0340X	176.00
Brown - Polyurethane				
76-710TF	32	220g	-0361B	160.00
76-712TF	38	322g	-0362C	176.00
76-714TF	44	494g	-0363D	258.00
76-716TF	50	658g	-0364E	284.00
76-720TF	60	880g	-0365F	387.00
White - Hard Nylon				
76-708NF	25	170g	-0335A	106.00
76-710NF	32	184g	-0336B	140.00
76-712NF	38	275g	-0337C	164.00
76-714NF	44	420g	-0338D	212.00
76-716NF	50	540g	-0339E	266.00
76-720NF	63	680g	-0340F	361.00
Yellow - Extra Hard Nylon				
76-710AF	32	193g	-0321B	129.00
76-712AF	38	281g	-0322C	160.00
76-714AF	44	398g	-0323D	205.00
76-716AF	50	524g	-0324E	258.00

KENNEDY PROFESSIONAL Nylon Faced Safe Blow Hammers



Hard nylon faced hammer with 2 screw-on all purpose striking faces which can easily be replaced manually without the use of any other tools - minimising downtime.

Hollow chrome plated zinc head partially filled with steel pellets which impact a split second after the hammer face, reducing rebound, fitted with a fully moulded polypropylene shaft with soft feel dual material grip. There are no metal parts in the striking faces which could mar the workpiece as the head wears down.

The striking faces are reinforced for extra strength and to prevent fracture from 'off-target' hits.

Precision grooves in the metal head prevent faces from vibrating loose during use.

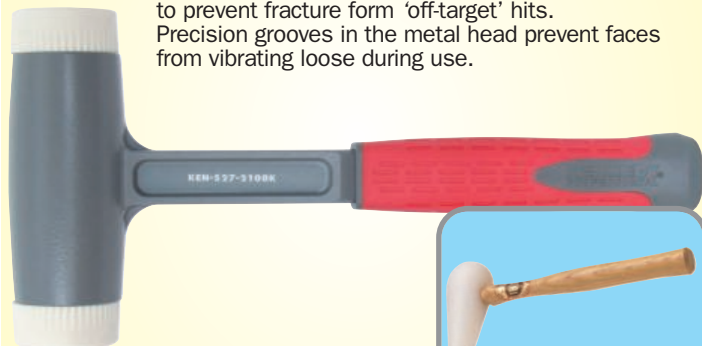

See Page 908

Face (mm)	Overall Length	Order Code KEN-527	Price/1 TB
32	340mm	-2040K	1577.00
38	340mm	-2060K	1704.00
44	340mm	-2080K	1765.00
50	340mm	-2100K	1906.00

Junior Thorlite Rubber Hammer

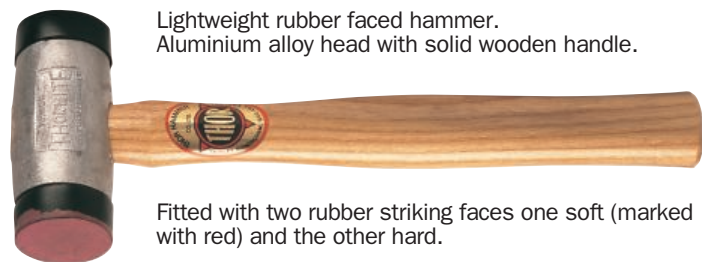

Lightweight rubber faced hammer. Aluminium alloy head with solid wooden handle.

Fitted with two rubber striking faces one soft (marked with red) and the other hard.

Product Number	Face (mm)	Length (mm)	Weight each	Order Code THO-527	Price/1 TB
09-J612	40	280	320g	-0550D	712.00

Spare Striking Faces for the Junior Thorlite Hammer

Product Number	Face (mm)	Weight Per 10	Order Code THO-529	Price/1 TB
75-612HF	40	350g	-0280P	129.00
75-612SF	40	412g	-0282R	140.00

Shaped Rubber Head Hammer Set

Five piece set contents: aluminium alloy hammer head with self locking wooden handle and four shaped rubber striking faces, flat, dome, cone and wedge.



Product Number	Face (mm)	Length (mm)	Weight each	Order Code THO-527	Price/1 TB
09-616	50	305	560g	-0276K	1442.00

PRODUCTS ARE ONLY AVAILABLE VIA YOUR DISTRIBUTOR

GROUP 527 HAMMERS - INSERTED FACE

THOR HAMMER *Soft Faced Hammers*

A safer alternative for striking machined surfaces than conventional steel hammers. The impact resistant striking faces shape themselves to the component being struck, minimising rebound damage to the component and reducing noise pollution in the workplace. The striking faces can be easily replaced once they have become worn. Available as standard, with a choice of five interchangeable face types.

Rawhide Faced Hammers

Head manufactured from malleable iron fitted with two rawhide striking faces and solid wooden handle. Rawhide manufactured from genuine water buffalo hide, tightly coiled and pressed three times under powerful hydraulic presses to ensure uniform quality and maximum durability.



Product Number	Size Ref.	Face (mm)	Length (mm)	Weight each	Order Code THO-527	Price/1 TB
01-008	A	25	230	340g	-0100A	1384.00
01-010	1	32	280	600g	-0101B	1886.00
01-012	2	38	305	825g	-0102C	2159.00
01-014	3	44	305	1300g	-0103D	2059.00
01-016	4	50	355	2000g	-0104E	2730.00
01-022	5	70	405	3150g	-0105F	4119.00
01-022	5	70	900	3150g	-0106G	4069.00

Copper Faced Hammers

Malleable iron head with two pure electrolytic copper faces, for high impact blows. Solid wooden handle.



Due to the fluctuating price of **COPPER**, SURCHARGES may apply

Product Number	Size Ref.	Face (mm)	Length (mm)	Weight each	Order Code THO-527	Price/1 TB
04-308	A	25	230	475g	-0160G	1075.00
04-310	1	32	280	850g	-0161H	1698.00
04-312	2	38	305	1300g	-0162J	2326.00
04-314	3	44	305	1975g	-0163K	2955.00
04-316	4	50	355	2950g	-0164L	4839.00
04-316WT	4	50	355	2950g	-0164T	4839.00
04-317	4	50	760	3350g	-0165M	5594.00
04-322	5	70	915	6350g	-0167P	7725.00

Dual Purpose Rawhide and Copper Faced Hammers

Malleable iron head with solid wooden handle. The pure electrolytic copper striking face provides a safe high impact blow whilst the rawhide face gives a firm resilient blow that will not mark finished work.



Due to the fluctuating price of **COPPER**, SURCHARGES may apply

Product Number	Size Ref.	Face (mm)	Length (mm)	Weight each	Order Code THO-527	Price/1 TB
03-208	A	25	230	400g	-0150A	1242.00
03-210	1	32	280	725g	-0151B	1711.00
03-212	2	38	305	1070g	-0152C	2201.00
03-214	3	44	305	1650g	-0153D	2829.00
03-216	4	50	355	2500g	-0154E	4085.00
03-222	5	70	915	5150g	-0155F	6438.00

Aluminium Faced Hammers

Malleable iron head fitted with solid shaft and two ductile aluminium faces.



Product Number	Size Ref.	Face (mm)	Length (mm)	Weight each	Order Code THO-527	Price/1 TB
05-A308	A	25	230	340g	-0500A	617.00
05-A310	1	32	280	660g	-0501B	823.00
05-A312	2	38	305	950g	-0502C	1029.00
05-A314	3	44	305	1440g	-0503D	1391.00
05-A316	4	50	355	2200g	-0504E	2059.00

Plastic Faced Hammers

Malleable iron head, fitted with two white high molecular weight polythene striking faces for high impact applications.

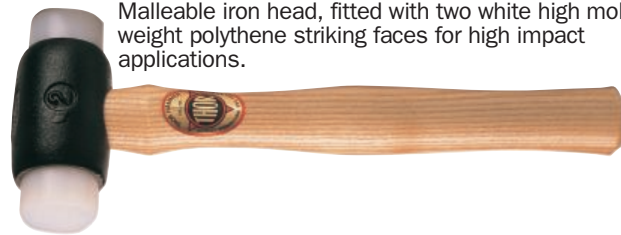

Product Number	Size Ref.	Face (mm)	Length (mm)	Weight each	Order Code THO-527	Price/1 TB
18-908	A	25	220	470g	-0400A	773.00
18-910	1	32	280	600g	-0401B	1029.00
18-912	2	38	305	790g	-0402C	1236.00
18-914	3	44	310	1700g	-0403D	1494.00
18-916	4	50	355	2000g	-0404E	2059.00
18-922	5	70	405	3000g	-0405F	3089.00

Spare Striking Faces

For malleable iron head hammers and split head hammers.



Due to the fluctuating price of **COPPER**, SURCHARGES may apply

Product Number	Size Ref.	Face (mm)	Weight each	Order Code THO-529	Price/1 TB
Rawhide					
70-8R	A	25	18g	-0115A	258.00
70-10R	1	32	36g	-0116B	308.00
70-12R	2	38	54g	-0117C	411.00
70-14R	3	44	73g	-0118D	449.00
70-16R	4	50	97g	-0119E	696.00
70-22R	5	70	203g	-0120F	1183.00
Copper					
71-308C	A	25	86g	-0171N	264.00
71-310C	1	32	145g	-0172P	411.00
71-312C	2	38	241g	-0173Q	574.00
71-314C	3	44	352g	-0174R	780.00
71-316C	4	50	540g	-0175S	1183.00
71-322C	5	70	1283g	-0176T	2380.00
Aluminium					
71-310AF	1	32	47g	-0141E	140.00
Plastic					
77-908SPF	A	25	15g	-0411G	133.00
77-910SPF	1	32	20g	-0412H	165.00
77-912SPF	2	38	38g	-0413J	232.00
77-914SPF	3	44	47g	-0414K	284.00
77-916SPF	4	50	74g	-0415L	361.00
77-922SPF	5	70	146g	-0416M	617.00
Nylon					
76-125NF	1	32	20g	-0125L	266.00
76-150NF	2	38	32g	-0126M	292.00
76-175NF	3	44	47g	-0127N	361.00
76-200NF	4	50	63g	-0128P	478.00
76-275NF	5	70	138g	-0129R	823.00

HAND TOOLS

SITESAFE Pick Axe Handles

Manufactured to **BS 3823**.
Overall length: 950mm (36").

S71440 - Economy

Made from genuine hickory with a waxed finish.

S71410 - Hickory

Handle to fit standard pick axe or mattock eye. Hickory shaft fitted with a plastic head designed for increased grip in the eye of the pick axe or mattock head once fitted.



Product Number	Shaft Type	Order Code	Price/1 TB
S71440	Economy	-6511B	711.00
S71410	Hickory	-6512C	773.00

KENNEDY Hammer Shafts

Made from genuine hickory with a waxed finish.
Manufactured to **BS 3823**.

Pick Axe - Hickory



Length (mm)	For Head Weight	Weight each	Order Code	Price/1 TB
920	8.5lb	950g	-3600K	1288.00

Pick Axe - Economy



Length (mm)	For Head Weight	Weight each	Order Code	Price/1 TB
920	8.5lb	950g	-3610K	384.00

Standard



Length (mm)	For Head Weight	Weight each	Order Code	Price/1 TB
280	1/4lb	30g	-0110K	205.00
305	1/2lb	35g	-0120K	205.00
330	1lb	135g	-0130K	222.00
380	1 1/2lb	230g	-0150K	232.00
405	2lb	250g	-0160K	258.00
455	3lb	320g	-0180K	284.00

Club



Length (mm)	For Head Weight	Weight each	Order Code	Price/1 TB
255	2 1/2/4lb	170g	-1100K	176.00

Sledge



Length (mm)	For Head Weight	Weight each	Order Code	Price/1 TB
610	4lb	330g	-2240K	361.00
760	7lb	710g	-2300K	464.00
910	10/14lb	860g	-2360K	567.00

Claw



Length (mm)	For Head Weight	Weight each	Order Code	Price/1 TB
330	13/16oz	190g	-3130K	205.00
355	20/24oz	200g	-3140K	222.00

Hammer Wedges

Manufactured from high grade steel.



Wedge Size	For Head Weight	Weight Per 100	Order Code	Price/1 TB
1	up to 12oz	210g	-4510K	23.00
2	14oz to 2 1/2lb	430g	-4520K	28.00
3	3lb to 7lb	580g	-4530K	23.00
4	10lb to 28lb	770g	-4540K	33.00
5	Above 28lb	3500g	-4550K	66.00



KENNEDY File Handles

Polypropylene file handles with integral hanging hole and covered with a ribbed rubber grip for increased purchase and added comfort.

Available in three sizes: 0, 1 and 2.



Size	Suitable File Length (mm)	Order Code	Price/1 TB
No. 0	100 - 150	-5000K	110.00
No. 1	200 - 250	-5010K	116.00
No. 2	300 - 400	-5020K	165.00



Safety Wooden File Handles

A split file handle can cause a serious industrial accident. Kennedy safety handles are rapidly becoming standard equipment in workshops. Firmly secured inside each handle and covered by a ferrule is a steel spring, this combination absorbs the pressure when the tang of the file is driven into the handle, prevent splitting or cracking. Once properly inserted the tang of the file is held in a vice like grip that under normal use is virtually impossible to remove, unless the handle is deliberately broken.

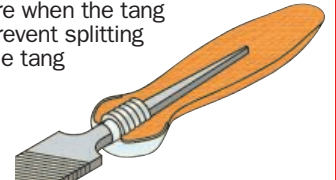

Handle Length	Size	Suitable File Length	Weight each	Order Code	Price/1 TB
75mm	0	4"	20g	-5730K	362.00
110mm	1	6" - 8"	45g	-5740K	277.00
125mm	2	10" - 12"	50g	-5750K	290.00
140mm	3	14" - 16"	70g	-5760K	290.00

Standard Wooden File Handles

Suitable for traditionally tanged engineers' files. With steel ferrule.



Handle Length	Size	Suitable File Length	Weight each	Order Code	Price/1 TB
75mm	-	4" - 6"	20g	-5300K	41.00
100mm	-	8"	25g	-5400K	47.00
125mm	-	10"	45g	-5500K	51.00
150mm	-	12" - 16"	60g	-5600K	59.00

Moulded Plastic File Handles

With contoured grip and hanging hole.



Handle Length	Size	Suitable File Length	Weight each	Order Code	Price/1 TB
75mm	0	4" - 6"	10g	-5930K	89.00
90mm	1	8" - 10"	50g	-5940K	117.00
100mm	2	10" - 12"	80g	-5950K	144.00

HAND TOOLS

GROUP 533 DECORATING TOOLS

KENNEDY PROFESSIONAL Decorator's Scrapers

For scraping paint and varnish off wood. High carbon steel double edged blade. Convex edges to reduce surface damage. Bi-material comfort grip. Supplied with a two or four edge blade.



The replacement blades are one piece - two or four edged and be changed by unscrewing from the handle and rotating to a new edge.

Type	Blade width	Order Code KEN-533	Price/1 TB
Two Edge	38mm	-1600K	239.00
Four Edge	65mm	-1620K	315.00
Replacement Blades			
For Two Edge	38mm	-1660K	88.00
For Four Edge	65mm	-1680K	114.00

Bi-material Window Scraper **NEW**



Suitable for scraping paint from glass, this tool has an ergonomic, bi-material design to provide users with a comfortable non-slip grip. Blade storage in handle.



Overall Length (mm)	Weight each	Order Code KEN-533	Price/1 TB
245	50g	-1100K	155.00
Blades (Pk 10)		KEN-537-7560K	102.00

SENATOR QUALITY TOOLING President Decorator's Tools



High carbon, clear lacquered steel blades with quality wooden handles and half tang fixing. Suitable for general duty and household use.

Scrapers (Half Tang)



Blade Length x Width (mm)	Weight per 12	Order Code SEN-533	Price/1 TB
100 x 140	1.50kg	-1700K	265.00
100 x 100	1.20kg	-1720K	247.00
90 x 75	1.10kg	-1740K	240.00
115 x 65	1.00kg	-1760K	206.00
90 x 50	0.90kg	-1780K	194.00
80 x 35	0.80kg	-1800K	177.00

HAND TOOLS

KENNEDY QUALITY INDUSTRIAL TOOLING Short & Long Handled Wall Scrapers

Wall scrapers that help remove wallcoverings, paint, floor and wall tiles more easily. The blunt side of the blade is useful for stripping off paint, removing wallcoverings and tiles, whilst the sharp edge will easily remove paint from glass. Blades are easily changed and replaced.



Type	Overall length	Weight each	Order Code KEN-533	Price/1 TB
Short	200mm	140g	-0580K	251.00
Long	315mm	160g	-0600K	267.00
100mm Scraper Blades (Pk 10)		65g	-0620K	73.00

Filling Knives (Half Tang)



Blade Length x Width (mm)	Weight per 12	Order Code SEN-533	Price/1 TB
100 x 140	1.30kg	-1500K	341.00
100 x 100	1.10kg	-1520K	270.00
100 x 80	1.00kg	-1540K	230.00
115 x 65	0.95kg	-1560K	228.00
90 x 50	0.85kg	-1580K	190.00
85 x 35	0.75kg	-1600K	173.00

Comfort Grip Scrapers (Scale Tang)

Heavy duty, with scale tangs, tempered flexible steel blades and bi-material comfort grips.



Blade Length x Width (mm)	Weight per 12	Order Code KEN-533	Price/1 TB
125 x 25	1.20kg	-5410K	389.00
125 x 50	1.40kg	-5420K	416.00
150 x 75	1.50kg	-5430K	525.00

Window Scraper

Snap resistant polypropylene handle. Supplied with hardened steel blade and removable plastic cover. Suitable for scraping paint off glass.

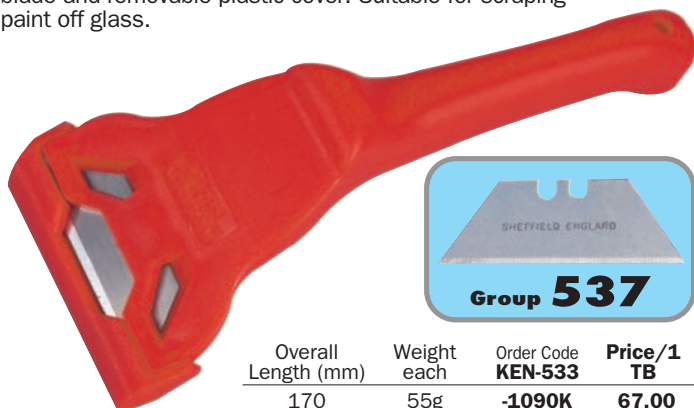

Overall Length (mm)	Weight each	Order Code KEN-533	Price/1 TB
170	55g	-1090K	67.00

Scrapers (Scale Tang)

Heavy duty, with scale tangs, tempered flexible steel blades and polished rosewood handles. Polished sharp blade for removing paint and wall coverings.



Blade Length x Width (mm)	Weight per 12	Order Code KEN-533	Price/1 TB
125 x 25	1.20kg	-0400K	668.00
125 x 38	1.20kg	-0410K	618.00
125 x 50	1.40kg	-0450K	719.00
125 x 63	1.45kg	-0490K	864.00
125 x 75	1.50kg	-0530K	801.00
150 x 100	1.60kg	-0570K	1115.00

Filling Knives (Scale Tang)

Heavy duty, with scale tangs, tempered flexible steel blades and polished rosewood handles. For applying and smoothing filler to cracks and holes.



Blade Length x Width (mm)	Weight per 12	Order Code KEN-533	Price/1 TB
125 x 50	1.30kg	-0650K	801.00
150 x 75	1.35kg	-0680K	855.00



SENATOR QUALITY TOOLING Putty Knives



Half Tang

Available in traditional clipt pattern or chisel pattern.

Clipt Point

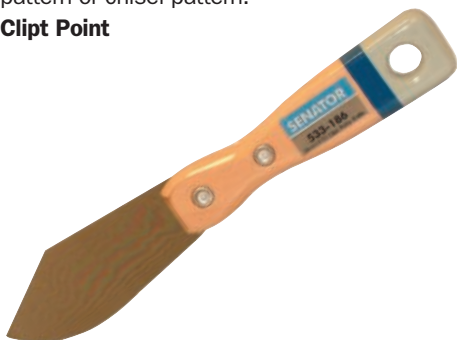

Blade Length x Width (mm)	Weight per 12	Order Code SEN-533	Price/1 TB
90 x 38 Clipt	0.80kg	-1860K	194.00

Chisel Point



Blade Length x Width (mm)	Weight per 12	Order Code SEN-533	Price/1 TB
57 x 38 Chisel	0.70kg	-1840K	183.00

Shave Hook

High carbon, clear lacquered steel blade with quality wooden handles and half tang fixing. Suitable for general duty and household use. Used for removing paint from flat, concave and convex mouldings.



Overall Length	Weight per 12	Order Code SEN-533	Price/1 TB
200mm	1.30kg	-1900K	244.00

Seam Roller

Plastic head.



Overall Length x Wheel Width	Weight per 12	Order Code SEN-533	Price/1 TB
180 x 38mm	0.60kg	-1920K	228.00

KENNEDY QUALITY INDUSTRIAL TOOLING Putty Knives

Scale Tang

Heavy duty, with scale tang, tempered flexible steel blade and polished rosewood handle. Traditional pattern glazier tool.

Clipt Point



Blade Length x Width (mm)	Weight per 12	Order Code KEN-533	Price/1 TB
115 x 38	1.20kg	-0860K	668.00

Chisel Point



Blade Length x Width (mm)	Weight per 12	Order Code KEN-533	Price/1 TB
115 x 38	1.20kg	-0960K	668.00

Combi Shave Hook

Heavy duty blade and quality wooden handle. For removing paint from flat, concave and convex mouldings.



Overall Length	Weight per 6	Order Code KEN-533	Price/1 TB
180mm	2.70kg	-1070K	302.00

Clipt Shoe Knife

Scale Tang

With heavy duty blade and quality wooden handle. General purpose cutting knife for many different applications.



Blade Length x Width (mm)	Weight per 12	Order Code KEN-533	Price/1 TB
100 x 25	870g	-1000K	299.00

Comfort Grip Putty Knife

Scale Tang

Heavy duty, with scale tang, tempered flexible steel blade and bi material comfort grips.

Clipt Point



Blade Length x Width (mm)	Weight per 12	Order Code KEN-533	Price/1 TB
115 x 38	1.20kg	-5500K	205.00

Palette Knives

Scale Tang

Heavy duty, with scale tang, tempered flexible steel blades and polished rosewood handles. Used for mixing paints, spreading printing inks, folding pigments etc.



Blade Length)	Weight each	Order Code KEN-533	Price/1 TB
100mm	60g	-5540K	274.00
150mm	88g	-5560K	286.00
200mm	159g	-5580K	306.00

Hooked Lino Knife

With heavy duty blade and quality wooden handle. For cutting linoleum and comparable materials.



Blade Length x Width (mm)	Weight per 12	Order Code KEN-533	Price/1 TB
90 x 25	1.50kg	-1020K	371.00

Hacking Knife

Scale Tang

Originally designed for chipping out old putty. The tough construction allows it to be used with a hammer.



Blade Length x Width (mm)	Weight per 12	Order Code KEN-533	Price/1 TB
115 x 30	2.40kg	-1060K	531.00

HAND TOOLS

GROUP 533 DECORATING TOOLS

KENNEDY Professional Paint Brushes

High quality lacquered wood handles. Chrome plated lapped and pressed ferrules. Long pure black high quality bristles. Hard wearing brushes designed to give long life and the finest of finishes for the true craftsman.

*With plastic handle.

Width (mm)	Weight per 12	Order Code KEN-533	Price/1 TB
13 (1/2")*	0.30kg	-5020K	63.00
19 (3/4")	0.65kg	-5030K	76.00
25 (1")	0.70kg	-5040K	82.00
38 (1 1/2")	0.95kg	-5050K	170.00
50 (2")	1.50kg	-5060K	222.00
63 (2 1/2")	1.75kg	-5070K	308.00
75 (3")	2.50kg	-5080K	464.00
100 (4")	3.40kg	-5090K	698.00



**5
PIECES**

**6
PIECES**

**11
PIECES**

Number of Pieces	Weight each	Order Code KEN-533	Price/1 TB
5	390g	-5130K	949.00
6	340g	-5170K	717.00
11	635g	-5140K	1577.00

5 Piece Set
1x 13, 25, 38, 50 and 75mm

6 Piece Set
3x 25mm, 2x 50mm and 1x 13mm

11 Piece Set
3x 25 and 50mm, 2x 13mm, 1x 19, 38 and 75mm

KENNEDY Industrial Paint Brushes

Plastic handles. Chrome plated lapped and pressed ferrules. Pure bristles vulcanised in rubber. Designed to give excellent results at an affordable price. For DIY and trade use.

Width (mm)	Weight per 12	Order Code KEN-533	Price/1 TB
13 (1/2")	0.25kg	-1120K	52.00
25 (1")	0.55kg	-1140K	119.00
38 (1 1/2")	0.70kg	-1160K	136.00
50 (2")	1.10kg	-1180K	171.00
75 (3")	1.80kg	-1220K	341.00
100 (4")	2.60kg	-1240K	525.00

**14
PIECES**



14 Piece Set
4x 13, 25 and 50mm, 1x 75 and 100mm.

Number of Pieces	Weight each	Order Code KEN-533	Price/1 TB
14	0.85kg	-1300K	1288.00

KENNEDY Professional Paint Brushes - Synthetic

A range of long lasting synthetic filament paint brushes specifically designed for the professional for achieving very fine finishes with all paints and available in a range of sizes from 1/2" to 4". With cushioned rubber grip handles.

NEW

Width (mm)	Order Code KEN-533	Price/1 TB
13 (1/2")	-6762K	57.00
25 (1")	-6764K	67.00
38 (1 1/2")	-6766K	78.00
50 (2")	-6768K	88.00
75 (3")	-6772K	134.00
100 (4")	-6776K	205.00

**6
PIECES** **14
PIECES**



Width (mm)	Order Code KEN-533	Price/1 TB
6 Piece Set	-6790K	514.00
14 Piece Set	-6794K	1029.00

6 Piece Set
1x 1/2", 3x 1", and 2x 2".

14 Piece Set:
4x 1/2", 4x 1", 4x 2", 1x 3", and 1x 4".

SENATOR Paint Brushes

With painted wood handles. Chrome plated lapped and pressed steel ferrules. Long pure bristles.

Width (mm)	Weight each	Order Code SEN-533	Price/1 TB
13 (1/2")	15g	-0210K	44.00
19 (3/4")	25g	-0220K	44.00
25 (1")	30g	-0230K	61.00
38 (1 1/2")	43g	-0240K	81.00
50 (2")	65g	-0250K	140.00
63 (2 1/2")	85g	-0260K	169.00
75 (3")	110g	-0270K	257.00
100 (4")	150g	-0280K	421.00



**6
PIECES**

**12
PIECES**

Number of Pieces	Weight each	Order Code SEN-533	Price/1 TB
6	330g	-0370K	361.00
12	865g	-0330K	926.00

6 Piece Set
1x 13mm, 3x 25 and 2x 50mm.

12 Piece Set
1x 19, 38, 63 and 100mm.
2x 13, 25, 50 and 75mm.

HAND TOOLS

KENNEDY Artist's Pencil Brushes

Plastic Handled - Medium Point

With pure bristles. Each brush is marked with its size. Medium point.



Size	Weight per 10	Order Code KEN-533	Price/1 TB
No.1	30g	-6391K	40.00
No.2	30g	-6392K	40.00
No.3	30g	-6393K	40.00
No.4	30g	-6394K	40.00
No.5	30g	-6395K	40.00
No.6	30g	-6396K	40.00

Wooden Handled - Medium Point

Steel ferrules. Soft hair bristles.



Size	Order Code KEN-533	Price/1 TB
No.1	-6721K	31.00
No.2	-6722K	31.00
No.3	-6410K	19.00
No.4	-6420K	19.00
No.5	-6430K	19.00
No.6	-6440K	25.00
No.7	-6450K	25.00
No.8	-6460K	30.00
No.10	-6470K	45.00
No.12	-6480K	45.00

Wooden Handled - Fine Point

Steel ferrules. Soft hair bristles.



Size	Order Code KEN-533	Price/1 TB
No.2	-6702K	26.00
No.4	-6704K	31.00
No.6	-6706K	37.00

Varnished Wooden Handled - Fine Point

Slimmer handles, steel ferrules, soft hair bristles.



Size	Order Code KEN-533	Price/1 TB
No.2	-6742K	37.00
No.3	-6743K	39.00
No.6	-6746K	42.00
No.8	-6748K	47.00

Fitch Brushes

Natural white bristle with long natural wooden handle and steel ferrule. Ideal for 'cutting-in' to corners and windows, or used dry to clean/dust on delicate objects or hard to access areas.



Type	Size	Order Code KEN-533	Price/1 TB
Flat	No.2 (6mm)	-6520K	30.00
	No.4 (8mm)	-6540K	30.00
	No.6 (12mm)	-6560K	30.00
	No.8 (16mm)	-6580K	30.00
	No.10 (20mm)	-6600K	61.00
	No.12 (24mm)	-6620K	129.00
Round	No.2 (6mm)	-6680K	27.00
	No.4 (8mm)	-6681K	27.00
	No.6 (12mm)	-6682K	27.00
	No.8 (16mm)	-6683K	56.00
	No.10 (20mm)	-6684K	56.00
	No.12 (24mm)	-6685K	80.00

Slant Cut Lining Brush

For use on fine and detailed decorating work and difficult to get to areas where the finish makes all the difference.

Overall Length: 300mm

Size	Order Code KEN-533	Price/1 TB
12mm (1/2")	-5220K	67.00

Paste & Glue Brush

1" brush with flat tip and short wooden handle ideal for use with paste and glue.

Size	Order Code KEN-533	Price/1 TB
25mm (1")	-5250K	57.00

Suds Brush

Twisted wire. For brushing down and clearing machine slide tables, engine parts etc.

Length	Weight each	Order Code KEN-907	Price/1 TB
240mm	20g	-3250K	38.00

Industrial Maintenance Brushes

Ideal for a wide variety of tasks around the workshop, home and for use when applying creosote, cleaners and degreasers etc. Wooden handles with pure bristles.

Size	Weight each	Order Code KEN-907	Price/1 TB
1/2"	13g	-0210K	38.00
1"	23g	-0250K	50.00
1 1/2"	39g	-0270K	62.00
2"	47g	-0290K	75.00
2 1/2"	63g	-0310K	86.00
3"	76g	-0330K	99.00
4"	100g	-0350K	227.00

Industrial Maintenance Brush Set

Superb value for money. Ideal for a wide variety of tasks around the workshop, home and for use when applying creosote, cleaners and degreasers etc. Wooden handles with pure bristles.

Contents:
4 off each:
12mm (1/2"),
25mm (1")
and 50mm (2");
1 off each:
75mm (3") and
100mm (4").



Number of Pieces	Weight each	Order Code KEN-907	Price/1 TB
14	200g	-0400K	804.00

DECORATING TOOLS

Radiator Brushes

Designed to reach behind radiators. Plastic handles with hard wearing bristles.

Size (mm)	Overall Length	Weight each	Order Code KEN-533	Price/1 TB
25	380	35g	-6020K	50.00
38	380	45g	-6030K	57.00
50	380	55g	-6040K	88.00

Wooden Sash Brushes

Wooden handle with steel ferrule.

Size	Order Code KEN-533	Price/1 TB
No.6	-3179K	93.00
No.8	-3180K	98.00
No.10	-3181K	103.00
No.12	-3182K	129.00
No.14	-3183K	134.00
No.16	-3184K	205.00
No.18	-3186K	308.00
No.20	-3187K	335.00

Laminating Brushes

Laminating brush for fibreglass and resin projects. White bristle, stainless ferrule. Cream plastic handle.

Size	Order Code KEN-533	Price/1 TB
1/2"	-6340K	38.00
3/4"	-6350K	48.00
1"	-6360K	59.00
2"	-6370K	70.00
3"	-6375K	91.00
4"	-6380K	129.00

Striker Brush c/w 24" Handle

Mainly used on heavy industrial and commercial work. Ideal for hard to reach painting work. 610mm (24") handle.

Size	Order Code KEN-533	Price/1 TB
1 1/2"	-0010K	205.00
2"	-0015K	308.00

Plastic Handle Sash Tools

Plastic handle. Ideal for cleaning out sawdust, swarf etc.

Size	Order Code KEN-533	Price/1 TB
No.6	-1531K	26.00
No.8	-1532K	52.00
No.10	-1533K	57.00
No.12	-1534K	62.00
No.16	-1535K	73.00

Paste/Glue Brushes

Size	Order Code KEN-533	Price/1 TB
No.9/3 (1/4")	-6310K	27.00
No.9/5 (3/4")	-6320K	38.00

GROUP 533 DECORATING TOOLS

KENNEDY Shepsil Refill
QUALITY INDUSTRIAL TOOLING

Suitable for emulsion and masonry paints on rough surfaces. Use also with vinyl silk, vinyl matt, exterior paints on rough surface

Core Diameter: 44mm.

To fit KENNEDY 230mm wide bird cage pattern rollers.



Length (mm)	Pile Length	Weight each	Order Code KEN-533	Price/1 TB
230 (9")	18mm	100g	-4300K	215.00

Polyester Extra Long Pile Refill

Suitable for emulsion and masonry paints on very rough surfaces. Also for use with vinyl silk, vinyl matt, exterior paints, on rough surfaces.

Core Diameter: 44mm

To fit KENNEDY 230mm wide bird cage pattern rollers.



Length (mm)	Pile Length	Weight each	Order Code KEN-533	Price/1 TB
230 (9")	32mm	100g	-4320K	199.00

Polyester Short Pile Refill

For eggshell paints on smooth surfaces. Use also with semi-gloss, vinyl silk, undercoat, primers on smooth flat surfaces

Core Diameter: 44mm.

To fit 230mm wide bird cage pattern rollers.



Length (mm)	Pile Length	Weight each	Order Code KEN-533	Price/1 TB
230 (9")	9mm	100g	-4330K	88.00

Foam Roller - Textured Paint

For applying and finishing texture paints, use for applying and texturing high-build, aggregate and texture paints on interior walls, exterior walls and ceilings.

Core Diameter: 44mm

To fit KENNEDY 230mm wide bird cage pattern rollers.



Length (mm)	Roller Type	Weight each	Order Code KEN-533	Price/1 TB
230 (9")	Foam	100g	-4340K	258.00

Medium Pile Refill

For double arm rollers. Medium pile, suitable for rough surfaces such as stucco, concrete, pebble dash, embossed wallpaper, brick and block walls.

To fit KENNEDY 300mm wide double arm roller head.



Size (mm)	Weight each	Order Code KEN-533	Price/1 TB
300 (12")	100g	-4600K	368.00

Sheepskin Roller

Suitable for emulsion, exterior and masonry paints on rough surfaces.

Core Diameter: 44mm

To fit KENNEDY 230mm wide bird cage pattern rollers.



Length (mm)	Pile Length	Weight each	Order Code KEN-533	Price/1 TB
230 (9")	18mm	100g	-4350K	567.00

SENATOR Economy Refill Sleeves
QUALITY TOOLING

Medium pile is suitable for smooth surfaces. Long pile is suitable for rough surfaces.

Pile Diameter: 38mm

To fit SENATOR 180mm & 230mm wide bird cage pattern rollers.



Length (mm)	Pile	Order Code SEN-533	Price/1 TB
180 (7")	Medium	-4200K	156.00
230 (9")	Medium	-4310K	169.00
180 (7")	Long	-4220K	157.00
230 (9")	Long	-4320K	182.00

Telescopic Extension Pole

Manufactured to the highest specifications from aluminium, fibre-glass and ABS plastic, making it light in weight but very strong. It extends from 1.2 to 2.4m and comes with an American style thread plus ascrew-on tapered adaptor.



Extension Range	Weight each	Order Code KEN-533	Price/1 TB
1.2 to 2.4m (47" to 94")	360g	-4800K	980.00

SENATOR Telescopic Extension Handle
QUALITY TOOLING

To fit 230mm (9") wide bird cage pattern roller.

Extension Range	Weight each	Order Code SEN-533	Price/1 TB
1 to 2m (42" to 84")	360g	-4800K	633.00

230mm (9") Extending Bird Cage Paint Roller Frame

This innovative two stage extending bird cage roller is very versatile as it extends from 430mm (17") to 680mm (27") by extending the handle and then up to 900mm (36") by extending the frame from the handle. Both operations are carried out by twisting to unlock, extending and twisting to lock again.

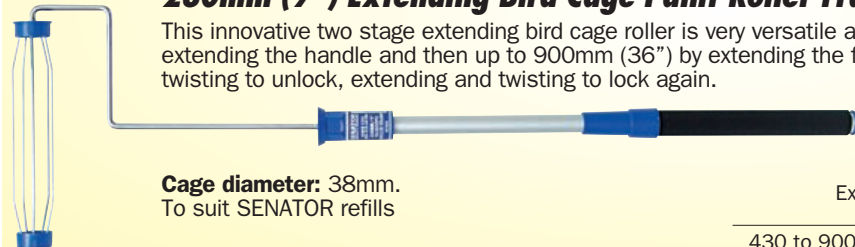

Cage diameter: 38mm.
To suit SENATOR refills

Extension Range	Weight each	Order Code SEN-533	Price/1 TB
430 to 900mm (17" to 36")	360g	-4420K	370.00

KENNEDY
QUALITY INDUSTRIAL TOOLING

Double Arm Roller Head

Galvanised steel double arm head. For use with 1" diameter stale with screw hole for fixing.



Size (mm)	Weight each	Order Code KEN-533	Price/1 TB
300 (12")	455g	-4650K	411.00

KENNEDY PROFESSIONAL

Paint Roller

Bird cage pattern with a hollow tapered wooden handle for use with extension.

Cage diameter: 44mm.
To suit KENNEDY refills.



Size (mm)	Weight each	Order Code KEN-533	Price/1 TB
230 (9")	400g	-4400K	370.00

SENATOR QUALITY TOOLING

Bird Cage Paint Roller

Black plastic handle with integral hanging hole for easy storage. For use with roller refill sleeves (not supplied).

Cage diameter: 38mm.
To suit SENATOR refills.



Size (mm)	Weight each	Order Code SEN-533	Price/1 TB
180 (7")	170g	-4250K	156.00
230 (9")	190g	-4400K	176.00

SENATOR QUALITY TOOLING **Roller Kit**

3
PIECES

3 Piece

Comprising of a bird cage paint roller, a medium pile refill and a plastic paint tray. Suitable for indoor use on smooth surfaces.



Number of Pieces	Weight each	Order Code SEN-533	Price/1 TB
3	548g	-4500K	421.00

Decorator's Set

8
PIECES

8 Piece

Comprising of a standard roller kit including a bird cage paint roller, medium pile refill and a plastic paint tray. Emulsion and gloss painting kit which includes a mini roller, refill, 50mm paint brush, paint tray and a 3.70 x 2.80m polythene dust sheet.



Number of Pieces	Weight each	Order Code SEN-533	Price/1 TB
8	750g	-3100K	572.00

Paint Pad Set

5
PIECES

5 Piece Contents:

Pad handle, paint tray (300 x 205mm), large pad (200 x 70mm), medium pad (140 x 70mm) and window frame pad (65 x 40mm).



Description	Order Code SEN-533	Price/1 TB
5 Piece Set	-4750K	282.00
200mm Pad Refill	-4700K	200.00

KENNEDY QUALITY INDUSTRIAL TOOLING **Mini Roller Set**

Supplied with a handle and tray. Includes a 100mm (4") high density foam roller for gloss and a knitted 100mm (4") sleeve for use with emulsion paint.

NEW

4
PIECES



Number of Pieces	Order Code KEN-533	Price/1 TB
4	-4140K	165.00

Floor Roller Paint Tray

380mm (15")

Large dimension paint tray designed for floor paint. Incorporates gullies for excessive paint drain. **Dimensions:** (W)15" x (L)17".



NEW

Width (mm)	Order Code KEN-533	Price/1 TB
380 (15")	-1760K	411.00

Floor Roller Paint Kit

300mm (12")

4 piece floor roller paint kit consisting of roller, roller bracket, extension arm and paint tray.



4
PIECES

NEW

Width (mm)	Order Code KEN-533	Price/1 TB
300 (12")	-1740K	850.00

Mini Emulsion Roller Set

100mm (4")

For use with emulsion paint.



Size (mm)	Order Code KEN-533	Price/1 TB
100 (4")	-4120K	132.00

Mini Gloss Roller Set

100mm (4")

For use with gloss paint.



Size (mm)	Order Code KEN-533	Price/1 TB
100 (4")	-4130K	163.00

Mini Paint Roller Tray

Tray to suit mini roller.



Description	Order Code KEN-533	Price/1 TB
To Suit Mini Roller	-4100K	63.00

Plastic 15ltr Paint Scuttle

15ltr paint scuttle in black plastic with metal handle. Moulded ridged sides for loading paint roller. Takes all paint roller frames up to 12".



Capacity	Weight each	Order Code KEN-533	Price/1 TB
15ltr	825g	-1700K	419.00

Paint Trays

The rigid drain off area helps remove the excess paint from the roller preventing drips and evenly coating your paint roller.

Dimensions (L x W x D): 400 x 290 x 60mm.



Type	Width (mm)	Weight each	Order Code KEN-533	Price/1 TB
Metal	230 (9")	570g	-4450K	489.00
Plastic	230 (9")	290g	-4460K	209.00
Metal	300 (12")	290g	-4670K	670.00

SENATOR QUALITY TOOLING **Paint Tray**

180mm (7") Paint Tray

Evenly coats the roller whilst storing paint in the reservoir. The drain-off area helps remove excess paint from the roller preventing drips.



Size (mm)	Weight each	Order Code SEN-533	Price/1 TB
180 (7")	165g	-4280K	94.00

Mini Paint Roller Frame

100mm (4")

Single arm type. Moulded plastic handle. Suitable for use with all 4" mini roller heads.



Size (mm)	Order Code KEN-533	Price/1 TB
100 (4")	-4060K	88.00

Long Arm Radiator Roller & Sleeve

Radiator roller frame and 4" roller sleeve. Single arm moulded handle frame and medium pile roller sleeve. Suitable for emulsion paint.



Description	Order Code KEN-533	Price/1 TB
Radiator Roller Complete	-4070K	88.00

Mini Roller Refills

100mm (4") medium pile roller for use with emulsion paints. Ideal for painting small areas or in awkward places.

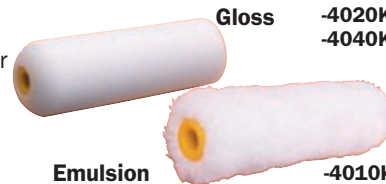

For Paint Types	Order Code KEN-533	Price/1 TB
Single Roll		
Emulsion	-4010K	114.00
Gloss	-4020K	114.00
Pack of 10 Rolls		
Emulsion	-4030K	270.00
Gloss	-4040K	365.00

HAND TOOLS

GROUP 533 DECORATING TOOLS

KENNEDY Paint Kettles
QUALITY INDUSTRIAL TOOLING

Made from high quality polypropylene and suitable for use with all types of paint. Robust plastic containers suitable for use in many applications holding liquids, compounds, fasteners and fixings. Tapered design to allow stacking and easy storage. Lids are sold separately. Supplied as standard with plastic handles (except *).



Capacity (Litres)	Dia. x Height (mm)	Order Code KEN-533	Price/1 TB
300ml*	89 x 66	-1540K	42.00
500ml*	100 x 720	-1545K	47.00
1ltr	140 x 102	-1550K	57.00
2.5ltr	198 x 134	-1560K	73.00
5ltr	235 x 205	-1564K	155.00
10ltr	282 x 229	-1568K	181.00
300ml	Lid Only	-1570K	16.00
500ml	Lid Only	-1571K	21.00
1ltr	Lid Only	-1573K	16.00
2.5ltr	Lid Only	-1575K	26.00
5ltr	Lid Only	-1577K	155.00
10ltr	Lid Only	-1579K	181.00



KENNEDY PROFESSIONAL Paint Kettles

Plastic paint kettles with steel wire handle. Inner lip has a 'V' cut to allow non-drip pouring.



Capacity	Order Code KEN-533	Price/1 TB
1ltr	-1520K	85.00
2.5ltr	-1530K	110.00



HAND TOOLS

KENNEDY Paste Brush
QUALITY INDUSTRIAL TOOLING

Easy clean synthetic bristle. Resin set in a nickel plated ferrule with plastic handle suitable for the easy spreading of wallpaper paste.



Width (mm)	Order Code KEN-533	Price/1 TB
120 (4 3/4")	-1500K	176.00

Dusting Brushes

Black pure bristle or soft coco fibre bristles. Plain wood handle. For general dusting and cleaning. Size: 100mm (4").



Type	Weight each	Order Code KEN-533	Price/1 TB
Coco	115g	-6824K	376.00
Pure	105g	-6844K	464.00

Plastic Bucket

Durable plastic rigid bucket with galvanised steel handle rotating plastic grip. Wide pouring lip and rounded reinforced edge. Three gallon (14ltr) capacity. Easy to clean smooth interiors and exteriors.



Capacity	Order Code KEN-907	Price/1 TB
3 gallon (14ltr)	-8030K	475.00



SENATOR Dust Sheet - Cotton Twill
QUALITY TOOLING

Economy cotton twill provide excellent protection to carpets, flooring and furniture whilst decorating.

Dimensions (L x W): 6ft x 3ft.



Dimensions (L x W)	Order Code SEN-533	Price/1 TB
6ft x 53ft	-7010K	205.00



KENNEDY Dust Sheets - Cotton Twill
QUALITY INDUSTRIAL TOOLING

Tough cotton twill provide excellent protection to carpets, flooring and furniture when painting.



Type	Size (L x W)	Order Code KEN-533	Price/1 TB
General	12ft x 9ft	-7000K	567.00
Staircase	3ft x 24ft	-7100K	720.00

Dust Sheet - Polythene

Disposable polythene dust sheet, thin polythene sheeting suitable for use once then thrown away.

Dimensions: 3.66 x 2.75m (12 x 9ft).



Description	Order Code SEN-533	Price/1 TB
Polythene Dust Sheet	-7040K	102.00

Dust Sheet Roll - Polythene

Disposable polythene dust sheet on a roll, suitable for staircases. Thin polythene sheeting suitable for use once then thrown away.

Dimensions: 2m x 50m.



Dimensions	Order Code KEN-533	Price/1 TB
2m x 50m	-7060K	335.00



KENNEDY *Glass & Tile Cutter*
QUALITY INDUSTRIAL TOOLING

Zinc alloy handle with a tungsten carbide cutting wheel.



Overall Length	Weight each	Order Code	Price/1 TB
130mm	45g	-1980K	132.00

Six Wheel Glass & Tile Cutter

Six wheel cutting head with tungsten carbide cutting wheels.



Overall Length	Weight each	Order Code	Price/1 TB
135mm	40g	-1990K	283.00

Tile Cutter/Scorer

Solid plastic handle with double edged tungsten, extra hard, carbide cutting tip.



Overall Length	Weight each	Order Code	Price/1 TB
100mm	40g	-2050K	82.00

SENATOR *Grout Remover*
QUALITY TOOLING

Long life tempered steel blade. Grout can be loosened and removed quickly and easily, for repair, renewal or 'facelift'.



Weight each	Order Code	Price/1 TB
50g	-2090K	136.00

Grout & Adhesive Spreader

Non-scratch plastic spreader. The grooved edge ensures that the adhesive is evenly spread. The flexible edge is suitable for removing excess grout.



Overall Length	Weight each	Order Code	Price/1 TB
180mm	43g	-1960L	142.00

Tile Spacers

Average pack quantity: 250.



Width	Weight per pk	Order Code	Price/1 TB
2mm	55g	-1940K	88.00

Contour Gauge

Allows profiles to be traced quickly and easily.



Overall Length (mm)	Weight each	Order Code	Price/1 TB
128 (5")	270g	-1960K	553.00
255 (10")	500g	-1950K	936.00

Tile Cutting Pliers

Tungsten carbide cutting wheel. The self-adjusting top jaw ensures a clean break. Suitable for use on ceramic tiles or glass.



Capacity (mm)	Weight each	Order Code	Price/1 TB
16 (5/8")	250g	-2070K	395.00
Spare cutter	5g	-2170K	122.00

200mm (8") Tile Nipper

Used for nibbling shapes in wall and floor tiles to make them fit around irregular shaped objects. Suitable for use on both ceramic wall and floor tiles. Drop forged steel handles and tungsten carbide tips.

Size: 6mm (1/4") capacity.



Size (mm)	Weight each	Order Code	Price/1 TB
200 (8")	345g	-8260K	641.00

Jumbo Sponge

Dimensions: 20 x 10 x 7cm. Yellow jumbo sponge.



Size	Order Code	Price/1 TB
20 x 10 x 7cm	-4150K	75.00

SENATOR *Tile Cutter*
QUALITY TOOLING

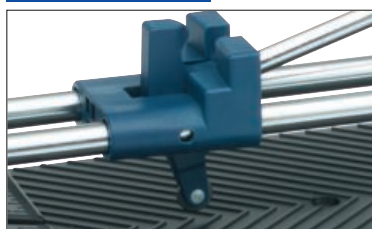

Quick Action Tile Breaker



Graduated Measuring Gauge

Push cut tile cutter with two steel bars as the handle guide. Tiles are scored with one smooth action and then snapped with the heavy duty tile breaker.

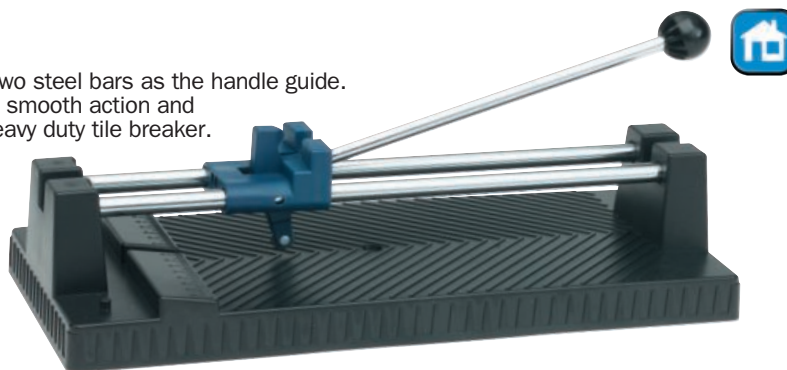

Tungsten Carbide Cutting Wheel

- Scores In one action with minimum pressure required.
- Ergonomic plastic handle and metal runners.
- High strength plastic base with serrated surface.

Capacity (mm)	Weight each	Order Code	Price/1 TB
260 (10")	1.20kg	-2060K	1214.00
Spare Wheel		-2150K	173.00

PRODUCTS ARE ONLY AVAILABLE VIA YOUR DISTRIBUTOR

HAND TOOLS

GROUP 533 SCISSORS

KENNEDY Industrial Scissors
QUALITY INDUSTRIAL TOOLING

Sidebent Shears

Stainless steel blades, large loop comfortable handles. For trimming.



Length (mm)	Weight each	Order Code KEN-533	Price/1 TB
180 (7")	190g	-2070K	284.00
205 (8")	190g	-2080K	335.00
230 (9")	280g	-2090K	387.00
255 (10")	440g	-2100K	438.00
305 (12")	720g	-2120K	567.00

Paper Hanging Shears

All metal, with stainless steel blades to produce perfect cuts.



Length (mm)	Weight each	Order Code KEN-533	Price/1 TB
255 (10")	270g	-2200K	752.00

Special Purpose Scissors Plastic Handled Tailor's Scissors

The asymmetrical plastic handle design allows the scissors to be used comfortably just above the work surface when cutting cloth in a straight line. The straight and curved blade tips are suitable for both long cuts and precise stitch cutting.



Length (mm)	Weight each	Order Code KEN-533	Price/1 TB
215 (8½")	140g	-3380K	489.00
240 (9½")	160g	-3390K	536.00

Tailor's Thread Cutting Snips

Plastic Handled

Handy, economical lightweight plastic snips with finger hole for stability. Replaceable stainless steel blades (uses Kennedy 533-375 blades). Useful for cutting threads, wires, string, plastic pull straps etc.



Length (mm)	Order Code KEN-533	Price/1 TB
125 (5")	-3750K	129.00

Bi-Material Handled Slimline Scissors

Bi-Material comfort handle. Slimline scissors ideal for fine and intricate detailed work.



Length mm	Order Code KEN-533	Price/1 TB
140 (5½")	-3920K	155.00
165 (6½")	-3930K	205.00

Bi-Material Side Bent Scissors

The asymmetrical plastic handle design with hardened and ground steel blades allows the scissors to be used comfortably just above the work surface when cutting cloth in a straight line. The straight and curved blade tips are suitable for both long cuts and precise stitch cutting. Sharp stainless steel blades.



Length mm	Order Code KEN-533	Price/1 TB
240 (9 ½")	-3780K	181.00

Bi-Material Handled Offset Scissors

The asymmetrical Bi-material comfort handle design with hardened and ground steel blades allows the scissors to be used comfortably just above the work surface when cutting cloth in a straight line. The straight and curved blade tips are suitable for both long cuts and precise stitch cutting. Sharp stainless steel blades.



Length mm	Order Code KEN-533	Price/1 TB
190 (7½")	-3940K	232.00
215 (8½")	-3950K	258.00
245 (9¾")	-3960K	335.00

Bi-Material Grip Scissors Set

5 Piece Set, Contents:

Slimline Scissors: 140mm and 165mm
Offset Scissors: 190mm, 215mm and 245mm



Number of Pieces	Order Code KEN-533	Price/1 TB
5	-3900K	361.00

Fibre Optic Cutters

FOC145

Designed for cutting fibre optics, KEVLAR materials, plastic canvas, upholstery, headlines, cloth, fabric, string and many more. Lightweight and easy to use for both right and left handed users. Easy reach thumb lock. Long lasting precision ground hardened high carbon alloy steel with molybdenum and vanadium blades. Serrated blade reduces slippage.



Overall length: 145mm (5")
Cutting length: 32mm (1")

Overall Length	Weight each	Order Code KEN-533	Price/1 TB
145mm	82g	-3570K	821.00

Fibre Optic Shears

FOC160

Designed for cutting fibre optics, KEVLAR materials, plastic canvas, upholstery, headlines, cloth, fabric, string and many more. Long lasting precision ground hardened high carbon alloy steel with Molybdenum and Vanadium blades. Serrated blade reduces slippage. Adjustable pivot point adjusts the tension between the blades. Extended tang for durability.



Overall length: 160mm
Cutting length: 42mm.

Overall Length	Weight each	Order Code KEN-533	Price/1 TB
160mm	82g	-3580K	931.00

HAND TOOLS

SENATOR *Paper Scissors*
QUALITY TOOLING



Non-twist blades manufactured from the finest quality stainless steel with plastic handles.

NEW



Length (mm)	Order Code SEN-533	Price/1 TB
140 (5½")	-0400K	102.00

General Purpose Household Scissors

Suitable for general cutting applications around the house. Hardened and ground steel blades with asymmetrical plastic handles.



NEW

Length (mm)	Order Code SEN-533	Price/1 TB
180 (7")	-0410K	129.00
215 (8½")	-0420K	140.00
255 (10")	-0430K	155.00

Kitchen Scissors - Offset Handle

The asymmetrical plastic handle design allows the scissors to be used comfortably just above the work surface when cutting cloth in a straight line. The straight and curved blade tips are suitable for both long cuts and precise stitch cutting. Hardened and ground steel blades



NEW

Length (mm)	Order Code SEN-533	Price/1 TB
115 (4½")	-0480K	129.00
180 (7")	-0490K	145.00
210 (8¼")	-0500K	205.00

KENNEDY *3 Piece Scissor Set*
QUALITY INDUSTRIAL TOOLING



190mm kitchen, 205mm heavy-duty and 215mm household.



Number of Pieces	Order Code KEN-533	Price/1 TB
3	-3700K	573.00

4 Piece General-Purpose Scissor Set

215mm tailors, 215mm kitchen, 170mm paper and 125mm thread cutting.



Number of Pieces	Order Code KEN-533	Price/1 TB
4	-3720K	698.00

KENNEDY *Paper Scissors*
QUALITY INDUSTRIAL TOOLING



Non-twist blades manufactured from the finest quality stainless steel with plastic handles.

Set contents: 160mm and 180mm

NEW



Length (mm)	Order Code KEN-533	Price/1 TB
160 (6¼")	-3800K	140.00
180 (7")	-3810K	160.00

General-Purpose Shears

Traditional pattern stainless steel scissors with high polished finish. Asymmetrical handle design for improved user comfort and control.



Length (mm)	Weight each	Order Code KEN-533	Price/1 TB
150 (6")	80g	-2260K	243.00
180 (7")	130g	-2270K	258.00

Multi-Purpose Shears

High strength reinforced offset steel blades with serrated cutting edge. Suitable for moderate to heavy cutting applications.



Length (mm)	Weight each	Order Code KEN-533	Price/1 TB
180 (7")	60g	-2370K	163.00

Heavy-Duty General Purpose Scissors

Kennedy heavy-duty general purpose scissors with large red loop handles.

NEW



Length (mm)	Order Code KEN-533	Price/1 TB
205 (8")	-3880K	438.00

2 Piece Paper Scissor Set

160mm and 180mm paper scissors.

NEW



Number of Pieces	Order Code KEN-533	Price/1 TB
2	-3850K	140.00

HAND TOOLS

GROUP 534 INSULATED SERVICE TOOLS

KENNEDY PROFESSIONAL

Insulated Adjustable Wrenches



Manufactured from chrome vanadium steel with hardened parallel opening jaws that are ground and polished, laser etched with metric graduations for rapid repeatable reference setting. The wide grooved profile of the opening mechanism and coarsely knurled adjusting screw ensures smooth adjustment. Fully insulated, conforms to **EN 60900:2012** standards for safe electrical applications up to 1000V.



Overall Length	Capacity	Weight each	Order Code KEN-534	Price/1 TB
200mm	24mm	336g	-6080K	2508.00
250mm	30mm	551g	-6100K	3086.00
300mm	34mm	870g	-6120K	3760.00

Insulated Spanners

Chrome vanadium single ended open jaw spanners. Spanner dimensions conform to **DIN 7446**. Fully insulated to conform to **VDE 0680/201** and **EN 60900:2012** standards for safe electrical applications up to 1000V.

Single End Open Jaw



Size	Weight each	Order Code KEN-534	Price/1 TB
10mm	30g	-8800K	858.00
11mm	45g	-8810K	858.00
12mm	60g	-8820K	858.00
13mm	60g	-8830K	880.00
14mm	70g	-8840K	993.00
15mm	85g	-8850K	993.00
16mm	115g	-8860K	1083.00
17mm	110g	-8870K	1128.00
18mm	135g	-8880K	1151.00
19mm	150g	-8890K	1174.00
21mm	205g	-8910K	1219.00
24mm	250g	-8940K	1286.00

Insulated Single End Ring Spanners



Size	Weight each	Order Code KEN-534	Price/1 TB
10mm	85g	-9200K	993.00
11mm	110g	-9210K	993.00
12mm	120g	-9220K	993.00
13mm	125g	-9230K	1083.00
14mm	175g	-9240K	1128.00
15mm	135g	-9250K	1263.00
16mm	175g	-9260K	1309.00
17mm	190g	-9270K	1399.00
18mm	220g	-9280K	1489.00
19mm	250g	-9290K	1579.00
21mm	310g	-9310K	1670.00
22mm	325g	-9320K	1760.00
24mm	340g	-9340K	1895.00

Insulated Hacksaw

Die cast frame with 'D' style handle for user comfort and control. Wing nut blade tensioning. Supplied complete with 300mm 24tpi blade. Fully insulated, conforms to **EN 60900:2012** standards for safe electrical applications up to 1000V.

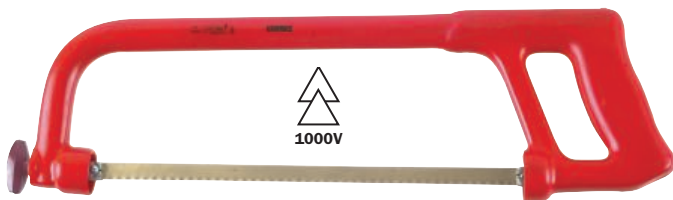

Overall Length	Weight each	Order Code KEN-534	Price/1 TB
400mm	619g	-0800K	3902.00

Insulated Pump/Box Joint Pliers

Hardened chromed steel jaws. Sliding pivot joint allows the widest range of jaw openings. Serrated jaws for gripping flat and round parts. The handles cannot be closed together, preventing trapped fingers.

Fully insulated, conforms to **EN 60900:2012** standards for safe electrical applications up to 1000V.



Overall Length	Weight each	Order Code KEN-534	Price/1 TB
240mm	55g	-4860K	2005.00

Insulated Tweezers

Straight/bent pattern tweezers with serrated gripping surfaces, quality tested and insulated to 1000V AC. Conforms to **EN 60900:2012** standards.

Overall length: 145mm. Exposed blade length: 15mm.



Straight Pattern



Bent Pattern



Overall Length	Weight each	Order Code KEN-534	Price/1 TB
145mm - Straight	40g	-1120K	975.00
145mm - Curved	40g	-1140K	1181.00

Insulated Junior Hacksaw

Quality tested and insulated to 1000V AC and 1500V DC for live line working. All insulation is moulded in one piece, thus avoiding possible air gaps or other potential hazards. Uses conventional junior hacksaw blades. **EN 60900:2012**.



Overall Length	Weight each	Order Code KEN-534	Price/1 TB
150mm (6")	264g	-0600K	2143.00

HAND TOOLS

KENNEDY PROFESSIONAL Insulated Cable Knives

Fully insulated to conform to **VDE 0680/201** and **EN 60900:2012** standards for safe electrical applications up to 1000V.



Curved Blade

Steel hook blade for splitting flat and ribbon cables along its length.



Straight Blade

Fixed straight blade and protection cap. **Blade length: 45mm.**



Overall Length	Weight each	Order Code KEN-534	Price/1 TB
180mm - Curved Blade	65g	-3480K	693.00
180mm - Straight Blade	65g	-3500K	568.00

Insulated Dismantling Cable Knife

Insulated dismantling cable knife complete with rotation cap. Quality tested to 1000V AC. Comfortable handle, fixed sickle shaped blade for cutting sector cables. Conforms to **VDE 0680/201** and **EN 60900:2012** standards. **Blade length: 45mm.**

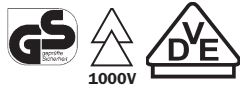

Overall Length	Weight each	Order Code KEN-534	Price/1 TB
180mm	70g	-3540K	1936.00

Insulated Sockets & Accessories

All products are quality tested and fully insulated to 1000V AC. Conforms to **VDE 0680/201** (except extension bars) and **EN 60900:2012** standards. All 1/2" square drive.

Insulated Reversible Ratchet Handle

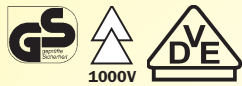

Description	Weight each	Order Code KEN-534	Price/1 TB
Reversible Ratchet Handle	660g	-7400K	5665.00

200mm Insulated T-Handle



Description	Weight each	Order Code KEN-534	Price/1 TB
200mm T-Handle	450g	-7420K	2884.00

INSULATED SERVICE TOOLS

Insulated Ratcheting Cable Cutter

For copper and aluminium cables up to 32mm diameter. Lightweight steel handles with insulated vinyl hand grips. Fixed and moving blade made from high grade alloy steel. Combines lightweight and ratcheted mechanical advantage in its circular cutting motion. Quality tested **EN 60900:2012** and insulated to 1000V AC.

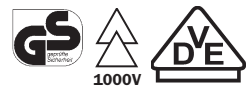

Overall Length	Weight each	Order Code KEN-534	Price/1 TB
250mm (10")	678g	-5000K	11939.00

Insulated Cable Cutters

Manufactured from drop forged high carbon steel with induction hardened blades. Fully insulated to conform with **VDE 0680/201** and **EN 60900:2012** standards for safe electrical applications up to 1000V.



Overall Length	Capacity	Weight each	Order Code KEN-534	Price/1 TB
240mm	22mm	398g	-4960K	2835.00

HAND TOOLS

125 & 250mm Insulated Extension Bars



Description	Weight each	Order Code KEN-534	Price/1 TB
125mm Extension Bar	200g	-7440K	1700.00
250mm Extension Bar	270g	-7460K	1906.00

Insulated Single Hexagon Sockets

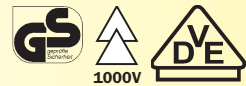

Type	Size	Overall Length	Weight each	Order Code KEN-534	Price/1 TB
Metric	10mm	37	60g	-7500K	768.00
	11mm	37	60g	-7510K	768.00
	12mm	37	60g	-7520K	768.00
	13mm	37	70g	-7530K	768.00
	14mm	37	60g	-7540K	768.00
	15mm	37	60g	-7550K	768.00
	16mm	37	70g	-7560K	789.00
	17mm	37	80g	-7570K	789.00
	18mm	37	90g	-7580K	789.00
	19mm	37	90g	-7590K	858.00
	20mm	37	100g	-7600K	880.00
	21mm	37	95g	-7610K	884.00
1/2"	22mm	37	105g	-7620K	902.00
	24mm	37	135g	-7640K	988.00

PRODUCTS ARE ONLY AVAILABLE VIA YOUR DISTRIBUTOR

GROUP 534 INSULATED SERVICE TOOLS

KENNEDY Insulated Interchangeable Screwdriver Set
QUALITY INDUSTRIAL TOOLING

Ergonomic insulated full size handle, swivel cap and eight interchangeable drivers supplied in a compact protective pouch with belt loop. 2-in-1 design, use the detachable swivel cap for fast (low torque) driving, or use the full size detachable ergonomic handle for higher torque fastening. Safe up to 1000V AC/1500V DC.



**10
PIECES**

10 Piece Set Contents (mm):

- PARALLEL**
- 0.4 x 2.5 x 100mm,
 - 0.5 x 3.0 x 100mm,
 - 0.8 x 4.0 x 100mm,
 - 1.0 x 5.5 x 100mm and
 - 1.2 x 6.5 x 100mm.

- CROSS POINT**
- No.0 x 100mm,
 - No.1 x 100mm and
 - No.2 x 100mm.



Number of Pieces	Weight each	Order Code	Price/1 TB
10	365g	KEN-572	2138.00

1000V Dual Grip VDE Screwdrivers

A fully insulated screwdriver VDE tested up to 1000V. Professional high grip handles, magnetic tips, chrome vanadium steel blades.



Crosspoint

Crosspoint screws virtually eliminate the screwdriver slippage if the correct size is used. The No.2 driver is suitable for most applications.



Parallel Tip

Slotted head screws are the most commonly used screw. To safely drive these screws, the tip of the screwdriver should be of the same width as the slot in the screw head and fill it as well, to minimise slipping and deforming the screw head.



Tip Size	Blade Length	Weight each	Order Code	Price/1 TB
No.0	60mm	20g	-7900K	342.00
No.1	80mm	60g	-7910K	399.00
No.2	100mm	90g	-7920K	476.00

Tip Size	Blade Length	Weight each	Order Code	Price/1 TB
2.5mm	75mm	20g	-7940K	342.00
4.0mm	100mm	60g	-7950K	399.00
5.5mm	125mm	75g	-7960K	510.00
6.5mm	150mm	110g	-7970K	554.00

Set Contents:

- PARALLEL**
- 2.5 x 75,
 - 4.0 x 100,
 - 5.5 x 125,
 - 6.5 x 150mm.

- CROSS POINT**
- No.0 x 60,
 - No.1 x 80,
 - No.2 x 100mm.

**7
PIECES**



Number of Pieces	Weight each	Order Code	Price/1 TB
7	715g	-8000K	1684.00

Electrician's VDE Square Section Handle Screwdrivers

Volt-tested to ensure safety on or near electrical equipment up to 1000V AC or 1500V DC. Insulated blades with magnetic tips. Conform with **DIN 7438** and **DIN EN 60900**.



Crosspoint

Crosspoint screws virtually eliminate the screwdriver slippage if the correct size is used. The No.2 driver is suitable for most applications.



Parallel Tip

Slotted head screws are the most commonly used screw. The tip of the screwdriver should be of the same width as the slot in the screw head and fill it as well, to minimise slipping.



Tip Size	Blade Length	Weight each	Order Code	Price/1 TB
No.0	75mm	27g	-5820K	106.00
No.1	100mm	50g	-5830K	126.00
No.2	100mm	80g	-5840K	146.00

Tip Size	Blade Length	Weight each	Order Code	Price/1 TB
2.5mm	85mm	30g	-5760K	120.00
4.0mm	100mm	45g	-5780K	125.00
5.5mm	125mm	80g	-5790K	175.00
6.5mm	150mm	100g	-5800K	183.00

Set Contents:

- Supplied in clear plastic wallet.
- PARALLEL**
- 2.5 x 85,
 - 4.0 x 100,
 - 5.5 x 125,
 - 6.5 x 150mm.

- CROSS POINT**
- No.0 x 75,
 - No.1 x 100,
 - No.2 x 100mm.

**7
PIECES**



Number of Pieces	Weight each	Order Code	Price/1 TB
7	495g	-5900K	1013.00

HAND TOOLS

KENNEDY PROFESSIONAL Pro-Torq Insulated Pliers

Especially suitable for production line environments where repetitive work is undertaken. Double polished head and joint with induction hardened cutting edges.

Insulated End Wire Strippers

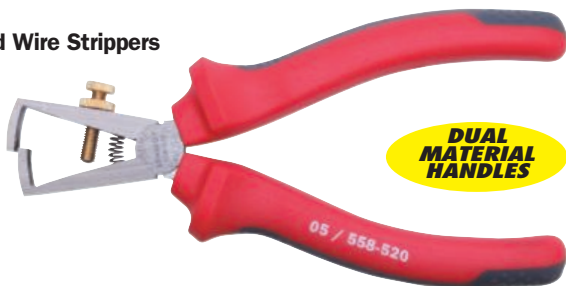

1000V AC
VDC/IEC 900
DIN EN 60900

Overall Length	Weight each	Order Code KEN-558	Price/1 TB
160mm (6 ³ / ₈ ")	199g	-5200K	583.00

Insulated Diagonal Cutting Nippers



Overall Length	Weight each	Order Code KEN-558	Price/1 TB
145mm (5 ³ / ₄ ")	215g	-5080K	646.00
160mm (6 ³ / ₈ ")	205g	-5100K	786.00
205mm (8")	262g	-5120K	831.00

Insulated Snipe Nose Pliers

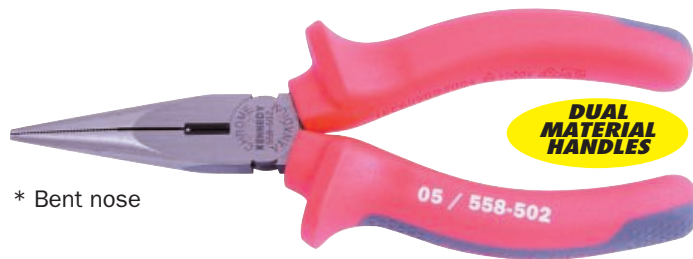

* Bent nose



Overall Length	Weight each	Order Code KEN-558	Price/1 TB
160mm (6 ³ / ₈ ")	157g	-5020K	589.00
205mm (8")	221g	-5040K	636.00
205mm (8")*	212g	-5060K	697.00

Insulated Combination Pliers



Overall Length	Weight each	Order Code KEN-558	Price/1 TB
160mm (6 ³ / ₈ ")	226g	-5140K	655.00
180mm (7")	290g	-5160K	690.00
205mm (8")	344g	-5180K	715.00

HAND TOOLS

16-Piece Electrician's VDE Tool Bag & Kit

Heavy-duty tear-resistant tool bag with velcro fastening flap. Double-webbed shoulder strap fixed with metal release clasps. Two removable tool boards inside which have a unique tool storage securing system built-in. All tools are VDE approved.



Contents:

- Electrician's tool bag (320 x 340 x 125mm).
- 150mm euro tester will detect 'live' electricity supply.
- Suitable for AC to 125 - 250V.
- 3mm wide tip. Conform to VDE 0630 Part 4.
- 145mm (5³/₄") Pro-Torq grip diagonal nipper 1000V insulated.
- 160mm (6³/₈") Pro-Torq snipe nose plier 1000V insulated.
- 165mm (6¹/₂") Pro-Torq engineers' combination plier 1000V insulated.
- 170mm (6³/₄") Pro-Torq wire stripper 1000V insulated.
- 7-pce VDE dual grip screwdriver set: No.0 x 60, No.1 x 80 and No.2 x 100mm, 2.5 x 75, 4.0 x 100, 5.5 x 125 and 6.5 x 150mm.
- 180mm (7") insulated cable knife, curved blade.
- 2x small parts storage boxes.



16 PIECES

Width (mm)	Depth (mm)	Height (mm)	Weight each	Order Code KEN-595	Price/1 TB
320	125	340	3.50kg	-3400K	8089.00

PRODUCTS ARE ONLY AVAILABLE VIA YOUR DISTRIBUTOR

GROUP 536 TAPE MEASURES

KENNEDY PROFESSIONAL

Auto Locking Tape Measures



Blades are reverse printed and have a nylon coating for extra life. The double-sided marking makes all the difference when measuring ceilings and window reveal etc. All come with an automatic brake which locks the blade in position during use until you press the release control button. They also benefit from a sliding magnetic hook and belt clip.



EEC CLASS II ACCURACY

Blade Length	Blade Width	Order Code KEN-536	Price/1 TB
3m	16mm	-1730K	N/A
5m	25mm	-1750K	N/A
3m/10'	16mm	-1830K	N/A
5m/16'	25mm	-1850K	N/A
8m/26'	25mm	-1880K	N/A

YAMOTO Rubber Grip Tape Measures



'Dynamic Grip'

Textured rubber non-slip grip case for improved comfort and impact resistance. Locking spring assisted blade return. Rivetted metal end hook. Steel belt clip and wrist strap. Action lock holds the blade precisely where you want it. Blades and hooks are heavy gauge and corrosion resistant, designed for industrial use. Self-aligning hooks ensure accuracy for internal and external measurements.



EEC CLASS II ACCURACY

5m and longer tape hooks have four rivets (3m/10' tape hooks have two). Metric/English blades have 1/32", 1/16" inch and mm graduations. Metric-only blades have mm and cm graduations.

Blade Length	Blade Width	Order Code YMT-536	Price/1 TB
3m	16mm	-1440K	100.00
5m	19mm	-1460K	133.00
8m	25mm	-1490K	N/A
3m/10'	16mm	-1430K	100.00
5m/16'	19mm	-1450K	133.00
7.5m/25'	25mm	-1480K	N/A
10m/33'	25mm	-1500K	N/A

HAND TOOLS

SENATOR Locking Tape Measures

Tough plastic case with a slide action blade lock. Locking spring assisted blade return. Rivetted metal end hook. Steel belt clip and wrist strap. Action lock holds the blade precisely where you want it. Blades and hooks are heavy gauge and corrosion-resistant. Self-aligning hooks ensure accuracy for internal and external measurements. 5m and longer tape hooks have four rivets (3m/10' tape hooks have two).

EEC CLASS II ACCURACY



Chrome Cased

Blade Length	Blade Width	Weight each	Order Code SEN-536	Price/1 TB
Metric Only Blades				
3m	16mm	130g	-6040K	N/A
5m	19mm	210g	-6060K	N/A
Metric & Inch Blades				
3m/10'	16mm	115g	-6030K	N/A
5m/16'	19mm	200g	-6050K	N/A
8m/25'	25mm	365g	-6080K	N/A

Plastic Cased



Blade Length	Blade Width	Weight each	Order Code SEN-536	Price/1 TB
7.5m/25'	25mm	195g	-0360K	N/A

Hi-Vis Cased



Blade Length	Blade Width	Weight each	Order Code SEN-536	Price/1 TB
Metric Only Blades				
3m	16mm	125g	-1440K	N/A
5m	19mm	195g	-1460K	N/A
Metric & Inch Blades				
3m/10'	16mm	130g	-1430K	N/A
5m/16'	19mm	215g	-1450K	N/A
7.5m/25'	25mm	365g	-1480K	N/A
10m/33'	25mm	470g	-1500K	N/A

Pull/Push Tape Measures

With spring blade return. Self-adjusting hook for internal and external reading. Metric and inch readings. ABS casing. End hook has two rivets, graduated with 1/32", 1/16" and mm.



EEC CLASS II ACCURACY

Blade Length	Blade Width	Order Code SEN-536	Price/1 TB
2m/6'	13mm	-1130K	N/A
3m/10'	13mm	-1140K	N/A

KENNEDY *Steel Tape Measures*
QUALITY INDUSTRIAL TOOLING

Non-reflective steel tape with nylon coated blade for maximum durability. The tape is housed in a high impact ABS plastic case with flush winding handle and belt clip. For ease of use, the tape is finished off with a handy plastic loop and metal end hook.



Blade Length	Order Code	Price/1 TB
20m/66'	KEN-536-3720K	N/A
30m/100'	-3740K	N/A

Surveyor's Fibreglass Tape Measures

A high tensile strength fibreglass tape that will never kink or rust. It is white on one side and yellow on the other to help prevent twisting and the blade is double-coated to protect the markings which feature both metric and imperial measurements. Housed in a robust ABS open frame with folding end claw and large D type handle with rubber insert for a comfort grip. It also has a quick, 2x fast retraction function and marking spike.



Blade Length	Order Code	Price/1 TB
50m/165'	KEN-536	N/A
100m/330'	-3960K	N/A
	-3990K	N/A

Road Measuring Wheel with Carry Case

Ideal for measuring distances to quantify distance or area for accurate ordering of aggregates, turf, tarmac, slabs and other large area requirements. Gear driven 5-digit counter mechanism with weather resistant housing, 'exact' point indicator, trigger operated brake, spring loaded kickstand and two reset buttons.



Metric Only

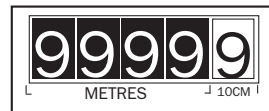

Five digit counter - reads up to 9,999.9m (10km)

Supplied in a carry case

Wheel Circumference	Weight Each	Order Code	Price/1 TB
320mm	2.00kg	KEN-536-9000K	N/A

SENATOR *Fibreglass Tape Measures*
QUALITY TOOLING

A high tensile strength fibreglass blade that is both water- and corrosion-proof. It has an easy to read dual scale (metric and imperial), reinforced blade tip and metal end claw. The tape is presented in an impact resistant ABS plastic case with flush fitting winding handle and convenient strap handle



Blade Length	Blade Width	Order Code	Price/1 TB
10m/33'	9.5mm	SEN-536-2420K	N/A
20m/66'	9.5mm	-2440K	N/A
30m/100'	9.5mm	-2460K	N/A

HAND TOOLS

GROUP 537 KNIVES

YAMOTO Folding Pocket Knife



Zinc die cast body. For all general-purpose cutting and trimming applications.

Body length: 100mm.

Open length: 135mm. Spring blade mechanism automatically locks the blade in open or closed position. Two blades can be stored in the body. Can be fitted to key ring.



Overall Length	Weight each	Order Code	Price/1 TB
135mm	84g	YMT-537 -1500K	235.00

Folding Pocket Knife Blades

Spare Knife Blades

Pack of five blades to suit (YMT-537-1500K) folding knife.



Pack Quantity	Weight each	Order Code	Price/Pk TB
5	22g	YMT-537 -1520K	144.00
50	22g	-1530K	492.00

KENNEDY Disposable Knife



Fixed ground steel blade. Non-slip finger/thumb grip. Ideal for industrial use, modelling and craft work.



Supplied with plastic safety cap with pocket clip.



Overall Length	Weight each	Order Code	Price/1 TB
155mm	9g	KEN-537 -0070K	50.00

HAND TOOLS

SENATOR 6-Blade Pocket Knife

Traditional style impact resistant plastic handle, with steel blades.

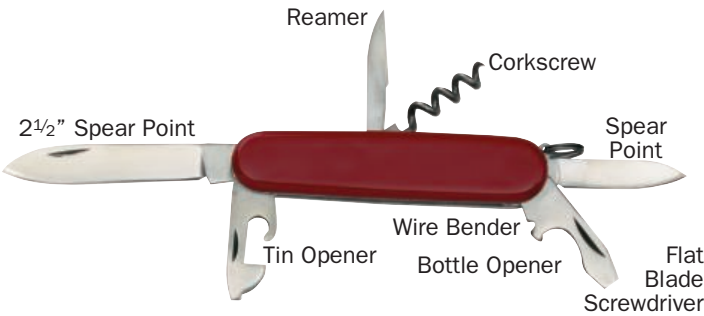

<input checked="" type="checkbox"/>	Spear Point	<input checked="" type="checkbox"/>	2 1/2" Spear Point	<input checked="" type="checkbox"/>	Scissors	<input checked="" type="checkbox"/>	Screwdriver & Bottle Opener	<input checked="" type="checkbox"/>	Tin Opener	<input checked="" type="checkbox"/>	Corkscrew	<input checked="" type="checkbox"/>	Wire Bender	<input checked="" type="checkbox"/>	Piercer/Reamer	<input checked="" type="checkbox"/>	File	<input checked="" type="checkbox"/>	Key Ring	<input checked="" type="checkbox"/>	No. of Blades	6		
																						Order Code SEN-537	Price/1 TB 187.00	
																							-1050K	187.00

11-Blade Pocket Knife

Traditional style impact resistant plastic handle, with stainless steel blades.

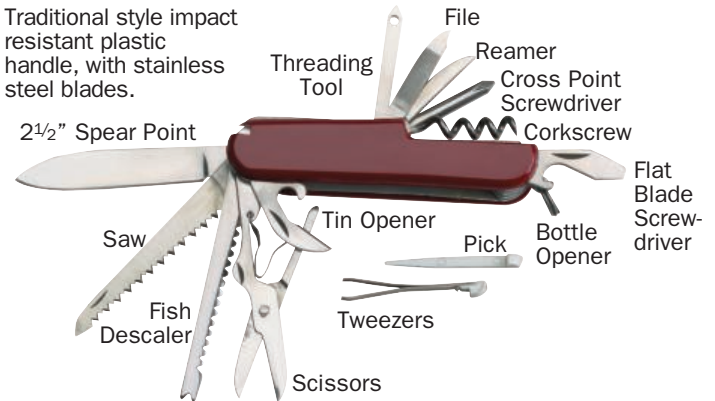

<input checked="" type="checkbox"/>	2 1/2" Spear Point	<input checked="" type="checkbox"/>	Saw	<input checked="" type="checkbox"/>	Scissors	<input checked="" type="checkbox"/>	Screwdriver & Bottle Opener	<input checked="" type="checkbox"/>	Tin Opener	<input checked="" type="checkbox"/>	Scissors	<input checked="" type="checkbox"/>	Fish descaler	<input checked="" type="checkbox"/>	Piercer/Reamer	<input checked="" type="checkbox"/>	Corkscrew	<input checked="" type="checkbox"/>	File	<input checked="" type="checkbox"/>	Threading Tool	<input checked="" type="checkbox"/>	Toothpick	<input checked="" type="checkbox"/>	Tweezers	<input checked="" type="checkbox"/>	No. of Blades	11	
																												Order Code SEN-537	Price/1 TB 308.00
																												-1100K	308.00

SENATOR Locking Knife

With rosewood handle. Stainless steel blade and brass fittings.



Blade Length	Weight each	Order Code	Price/1 TB
3"	160g	SEN-537 -1200K	464.00
4"	170g	-1300K	490.00

2-Blade Pocket Knife

With traditional style rosewood handle. Stainless steel blade and brass fittings.



Blade Length	Weight each	Order Code	Price/1 TB
2"	95g	SEN-537 -1000K	449.00

SENATOR Utility Knives
QUALITY TOOLING



A range of knives with contoured moulded grips and steel slides that prevent blade slippage or case splitting and gives the knife a smooth action. Snap-off blade knives have a blade locking mechanism in the thumb slide. Replacement blades available on request.

Snap-off Blade

8 segment, 18mm heavy duty.



Overall Length	Weight each	Order Code	Price/1 TB
130mm	60g	SEN-537	81.00

Snap-off Blade

13 segment, 9mm standard.



Overall Length	Weight each	Order Code	Price/1 TB
130mm	60g	SEN-537	31.00

Snap-off Blade Knife

8 segment, 18mm economy.



Overall Length	Weight each	Order Code	Price/1 TB
130mm	60g	SEN-537	82.00

YAMOTO Trimming Knives

Turn anti-clockwise to unlock. Turn continuously to disassemble for blade change.



13 Segments



8 Segments

Number of Segments	Order Code	Price/Pk TB
13	YMT-537	232.00
8	YMT-537	284.00

NEW

KENNEDY Snap-off Knife Blades
QUALITY INDUSTRIAL TOOLING



Kennedy Industrial quality knife blades have a superior edge hardening for longer tool life and sharper edge. Best value with longer working between blade changes and with easy, safe segment-snap to renew leading edge.

18 x 100mm - 8 segment



9 x 55mm - 7 segment



9 x 91mm - 13 segments



Overall Length	Pack Quantity	Weight each	Order Code	Price/Pk TB
18 x 100	10	72g	-2050K	88.00
18 x 100	100	73g	-2060K	1055.00
9 x 55	100	143g	-2020K	821.00
9 x 91	10	23g	-2110K	62.00
9 x 91	100	108g	-2120K	499.00

KENNEDY Autoload & Lock Knives
QUALITY INDUSTRIAL TOOLING



ABS plastic with rubber coating for extra grip, steel blade slides which prevent blade slippage or case splitting and gives the knife a smooth action. Snap off blade. Unique spring loaded automatic blade replacement.

KEN-537-0720K



KEN-537-0740K



Overall Length	Blade Segments	Weight each	Order Code	Price/1 TB
140mm	13	65g	KEN-537-0720K	165.00
170mm	8	165g	KEN-537-0740K	219.00

Snap-off Blade Retractable Knives

High strength ABS plastic construction with slider lock.

Mini: 140mm.

9 x 91mm, 13 segment blade.



Standard: 160mm. 18 x 100mm, 8 segment blade.



Overall Length	Weight each	Order Code	Price/1 TB
140mm	32g	KEN-537-0310K	116.00
160mm	86g	KEN-537-0350K	182.00

Mini: 9 x 91mm, 13 segment blade.



Overall Length	Weight each	Order Code	Price/1 TB
130mm	21g	KEN-537-0290K	50.00

Standard: 18 x 100mm. 8 segment blade.



Overall Length	Weight each	Order Code	Price/1 TB
160mm	38g	KEN-537-0370K	83.00

Ultra Slim

Precision knife. Black coated. 13 segment, blade 9 x 91mm.



Overall Length	Weight each	Order Code	Price/1 TB
130mm	20g	KEN-537-0250K	66.00

Micro Knife

9 x 55mm, 8 segment blade, without slider lock.



Overall Length	Weight each	Order Code	Price/1 TB
80mm	70g	KEN-537-0200K	40.00

YAMOTO Snap Off Knife Blades

NEW

Best value with longer working between blade changes and with easy, safe segment-snap to renew leading edge.



Number of Segments	Pack Quantity	Order Code	Price/Pk TB
8	10	YMT-537-1010K	57.00
8	100	YMT-537-1020K	617.00
13	10	YMT-537-1080K	109.00
13	100	YMT-537-1090K	876.00

HAND TOOLS

GROUP 537 KNIVES

KENNEDY
QUALITY INDUSTRIAL TOOLING

Automatic Retractable Safety Knife

Combined safety knife and strap/tape cutter. Features auto retractable blade and quick blade release, together with bi-material comfort grip. Accepts medium, heavy duty and hook blades.



Product Number	Order Code	Price/1 TB
	KEN-537	
SX1212	-0780K	593.00
Blades (pkt 3)	-7610K	129.00

Knife Blades

Kennedy Industrial quality knife blades have a superior edge hardening for longer tool life and sharper edge. Best value with longer working between blade changes. For use with fixed and retractable trimming knives and window scrapers. Suitable for Kennedy, Stanley, Irwin and other brands of knife.

Medium Duty
For use on paper, card and leather.



Pack Quantity	Weight per pack	Order Code	Price/Pk TB
		KEN-537	
5	30g	-2540K	107.00
100	250g	-2550K	446.00

Heavy Duty

For use on carpets and vinyl. Pack of five supplied in plastic case. Bulk pack of 100 supplied in card box.



Pack Quantity	Weight per pack	Order Code	Price/Pk TB
		KEN-537	
5	30g	-2560K	146.00
10	55g	-2500K	163.00
100	250g	-2570K	573.00

Hook Type

With point, suitable for use in packing industries for penetrating and cutting sheet materials.

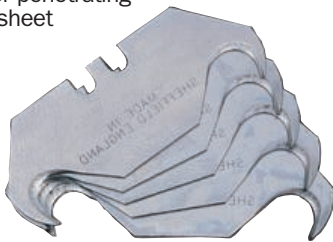

Pack Quantity	Weight per pack	Order Code	Price/Pk TB
		KEN-537	
5	30g	-2580K	146.00
100	250g	-2590K	1273.00

Automatic Retractable Quick Release Safety Knife

Designed for comfort and ease of use, this knife has auto retractable blade and bi-material comfort grip. It also features quick blade release and easy release blade storage. Comes complete with 4 blades.



Product Number	Order Code	Price/1 TB
	KEN-537	
SX660	-0790K	464.00

Trimming Knife

Fixed - Complete with 5 Blades

Die cast body with heavy duty knurled style for extra grip which provides a greater degree of control and comfort.



Overall Length	Weight each	Order Code	Price/1 TB
135mm	150g	KEN-537	197.00

Hercules Pattern Trimming Knife

Fixed Blade

Heavy duty fixed blade pattern, with interlocking body to prevent blade pop up during arduous cutting applications. The spring opening mechanism allows rapid replacement of dulled blades without the need for any other tool. Spare blades are stored in body. Supplied with impact resistant scabbard, integral belt clip and pencil holder for safe storage.



The spring opening mechanism allows rapid replacement of dulled blades

Overall Length	Weight each	Order Code	Price/1 TB
185mm	347g	KEN-537	466.00

AVON Carton Opener

For cutting through loading straps, extracting staples and slitting tape without damaging the contents. In-handle blade storage. Spring loaded blade guard, retractable slitting blade, complete with spare blade. **Overall length: 190mm**



Overall Length	Order Code	Price/1 TB
180mm	AVN-537	411.00

SENATOR Carton & Strap Cutter

For use on carton tape and plastic strapping. The blade is partially exposed to prevent accidental cuts.



Overall Length	Weight each	Order Code	Price/1 TB
80mm	10g	SEN-537	39.00

YAMOTO Trimming Knife Blades

Heavy-duty. For use on carpets and vinyl etc.



Pack Quantity	Order Code	Price/Pk TB
	YMT-537	
5	-4310K	67.00
10	-4320K	88.00
100	-4330K	773.00

AVON Cutting Safety Knife

High impact plastic handle with enclosed blade to ensure maximum user safety. Suitable for left and right handed users.



Overall Length	Weight each	Order Code	Price/1 TB
154mm		AVN-537	160.00

Fish 2000 Safety Knife

The Avon™ Fish 2000 safety knife has an enclosed blade within a 4.7mm gap and an auto-retracting hook blade, to ensure maximum user safety and to reduce accidental damage to the product in the carton being opened. It is suitable for both left and right-handed users.



Overall Length	Weight each	Order Code	Price/1 TB
155mm	50g	AVN-537	318.00

KENNEDY **Quick Release Folding Knife**
QUALITY INDUSTRIAL TOOLING

Quick release blade and folds to 9 x 3.5cm to stow using the integral belt clip. Accepts medium, heavy duty and hook blades. With blade guard.



Product Number	Order Code	Price/1 TB
KQF935	KEN-537 -0640K	384.00

Trimming Knife

Retractable Blade Knife with Scabbard
Trimming knife supplied with heavy duty blade and impact resistant scabbard.



Overall Length	Weight each	Order Code	Price/1 TB
170mm	300g	KEN-537 -1000K	493.00

Retractable - Complete with 5 Heavy Duty Blades

Slimline diecast body with contoured grip which provides a greater degree of control and comfort. High carbon steel blades. Up to five spare blades can be stored in the handle.



Overall Length	Weight each	Order Code	Price/1 TB
155mm	170g	KEN-537 -0510K	235.00

Quick Release Utility Knife

Classic design which features quick blade release, comfort grip handle and useful lanyard hole.



Product Number	Order Code	Price/1 TB
SX75N	KEN-537 -0800K	411.00

Twin Headed Quick Release Utility Knife

Two knives in one with an interlocking mechanism which ensures only one blade can be used at a time. Features quick blade release and easy blade change function.



Product Number	Order Code	Price/1 TB
SX3200	KEN-537 -0810K	617.00

SENATOR **Retractable Trimming Knife**
QUALITY TOOLING

Diecast aluminium body with retractable locking blade, built-in hanging hook. Complete with one spare blade.



Overall Length	Weight each	Order Code	Price/1 TB
160mm	150g	SEN-537 -0500K	226.00

Quick Change Utility Knife

An innovative sliding blade holder with durable soft touch composite casing. Quick and easy to change blade with no tools needed. Compatible with all standard utility blades. One handed operation.



Knife extends to allow auto-retractable blade to be used.

Overall Length	Weight each	Order Code	Price/1 TB
115mm	120g	KEN-537 -1120K	603.00

Auto Return

Fixed blade. Spring loaded plastic slide mechanism, automatically retracts the blade back into the handle when pressure is released. Accepts heavy duty blades only.



Overall Length	Weight each	Order Code	Price/1 TB
150mm	165g	KEN-537 -0515K	192.00

Retractable - Complete with 5 Heavy Duty Blades

Slimline die cast body designed to fit comfortably in the hand, with high carbon steel blades. Up to five spare blades can be stored in the handle.



Overall Length	Weight each	Order Code	Price/1 TB
160mm	120g	KEN-537 -0500K	192.00

YAMOTO **Wheel Lock Fixed Blade Trimming Knife**

Turn anti-clockwise to unlock. Turn continuously to disassemble for blade change.



Overall Length	Order Code	Price/1 TB
155mm	YMT-537 -4520K	258.00

Wheel Lock Retractable Blade Trimming Knife

Turn anti-clockwise to unlock. Turn continuously to disassemble for blade change.



Overall Length	Order Code	Price/1 TB
175mm	YMT-537 -4540K	335.00

HAND TOOLS

KENNEDY Non-Sterile Handles
QUALITY INDUSTRIAL TOOLING

No.3 & 4 Style

Non-sterile nickel alloy handle with textured body. For precision use in modelling and craft work.

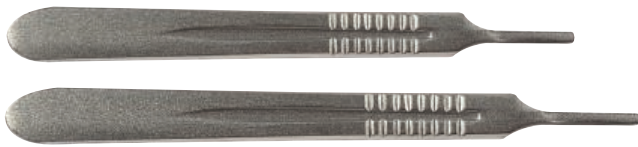

Handle Type	Overall Length	Weight each	Order Code KEN-537	Price/Pk TB
No.3	123mm	27g	-7230K	200.00
No.4	135mm	27g	-7240K	226.00

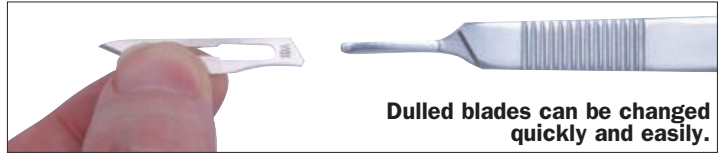

Dulled blades can be changed quickly and easily.

Carbon Steel Non-Sterile Blades

No.10A

Non-sterile, for use with No.3 type handle.



Style	Pack Quantity	Order Code KEN-537	Price/Pk TB
10A	100	-7015K	350.00

No.11

Non-sterile, for use with No.3 type handle.



Style	Pack Quantity	Order Code KEN-537	Price/Pk TB
11	100	-7025K	399.00

No.15

Non-sterile, for use with No.3 type handle.



Style	Pack Quantity	Order Code KEN-537	Price/Pk TB
15	100	-7035K	395.00

No.21

Non-sterile, for use with No.4 type handle.



Style	Pack Quantity	Order Code KEN-537	Price/Pk TB
21	100	-7045K	425.00

No.22

Non-sterile, for use with No.4 type handle.



Style	Pack Quantity	Order Code KEN-537	Price/Pk TB
22	100	-7055K	395.00

No.23

Non-sterile, for use with No.4 type handle.



Style	Pack Quantity	Order Code KEN-537	Price/Pk TB
23	100	-7065K	450.00



Each blade is packaged in safety foil for easier handling.

No.24

Non-sterile, for use with No.4 type handle.



Style	Pack Quantity	Order Code KEN-537	Price/Pk TB
24	100	-7075K	395.00

No.26

Non-sterile, for use with No.4 type handle.



Style	Pack Quantity	Order Code KEN-537	Price/Pk TB
26	100	-7085K	475.00

Precision Knives

Suitable for modellers art and craft workers and wood carvers. Ideal for making point of sale samples where precision cutting is required. Available in three styles:

Light duty: lightweight, small diameter aluminium handle suitable for cutting on paper, soft and lightweight materials or wood.



Medium duty: lightweight, large diameter aluminium handle suitable for cutting heavy paper and medium density materials.



Heavy duty: fluted, ABS plastic handle suitable for working with hardwood, plastic and other difficult to cut materials.



Product Number	Duty	Weight each	Order Code KEN-537	Price/1 TB
TK1	Light	28g	-4610K	154.00
TK2	Medium	47g	-4620K	165.00
TK5	Heavy	47g	-4630K	209.00

For replacement blades see next page

HAND TOOLS



KENNEDY **16-Piece Precision Knife Set**
QUALITY INDUSTRIAL TOOLING

**16
PIECES**

Multi-purpose knife set, ideal for modelling, craft work and industrial use. Covers a wide range of applications including cutting, chiselling, stencilling and scoring. All holders have a positive guide locator to provide extra safety when changing blades.

Contents:

- 1x light duty holder.
- 1x medium duty holder.
- 1x fluted ABS holder.
- 1x general cutting and trimming blade.
- 1x general cutting and slicing blade.
- 3x detail cutting and stripping blade.
- 1x medium/heavy duty cutting blade.
- 1x stencilling and scoring blade.
- 1x precision wood chiselling blade.
- 1x deep cross and smooth wood chiselling blade.
- 2x chiselling and trimming blade.
- 1x heavy duty cutting blade.
- 1x close corner cutting blade.



Number Of Pieces	Weight each	Order Code	Price/1 TB
16	235g	KEN-537	-5100K
			755.00

Kennedy Precision Blades
General Cutting & Trimming

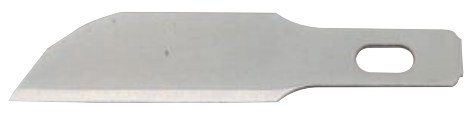

Pack Quantity	Weight each	Order Code	Price/Pk TB
10	9g	KEN-537	-7520K
			155.00

General Cutting & Slicing



Pack Quantity	Weight each	Order Code	Price/Pk TB
10	9g	KEN-537	-7280K
			212.00

Detail Cutting & Stripping



Pack Quantity	Weight each	Order Code	Price/Pk TB
5	8g	KEN-537	-7310K
			50.00

Stencilling & Scoring



Pack Quantity	Weight each	Order Code	Price/Pk TB
5	9g	KEN-537	-7350K
			155.00

Precision Wood Chiselling



Pack Quantity	Weight each	Order Code	Price/Pk TB
5	12g	KEN-537	-7550K
			155.00

Deep Cross & Wood Chiselling



Pack Quantity	Weight each	Order Code	Price/Pk TB
5	9g	KEN-537	-7400K
			155.00

Chiselling & Trimming



Pack Quantity	Weight each	Order Code	Price/Pk TB
10	10g	KEN-537	-7410K
			155.00

Heavy Duty Cutting



Pack Quantity	Weight each	Order Code	Price/Pk TB
5	9g	KEN-537	-7420K
			212.00

Close Corner Cutting



Pack Quantity	Weight each	Order Code	Price/Pk TB
10	9g	KEN-537	-7480K
			155.00

Medium/Heavy Duty Cutting



Pack Quantity	Weight each	Order Code	Price/Pk TB
10	10g	KEN-537	-7470K
			155.00



HAND TOOLS

GROUP 538 SAW FRAMES

KENNEDY Hacksaw Frames
QUALITY INDUSTRIAL TOOLING

Beaver Style

High impact resistant pistol grip. Steel oval section frame for strength and rigidity. Thumb screw blade tensioning. Supplied complete with 150mm (6") 18tpi metal cutting blade.



Overall Length	Weight per 12	Order Code KEN-538	Price/1 TB
275mm	1.80kg	-0630K	253.00

Pro-Grip Junior

Rigid steel frame. Contoured die cast handle with knuckle guard. Thumb screw blade tensioner. Complete with 150mm (6") blade.

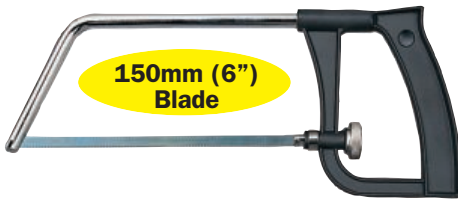

Overall Length	Weight per 12	Order Code KEN-538	Price/1 TB
235mm	2.50kg	-0550K	258.00

Low Profile Junior Hacksaw

Manufactured from rigid and lightweight aluminium with hi-strength I-beam frame. Moulded 'soft touch' cushion grip. Supplied with blade.

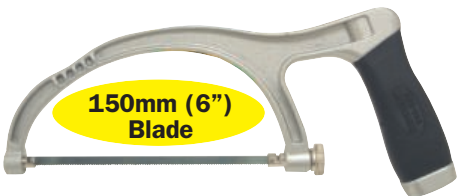

Overall Length	Weight per 12	Order Code KEN-538	Price/1 TB
250mm	2.70kg	-0500K	318.00

Standard Junior Pattern

Epoxy coated spring steel frame, keeps the blade tensioned correctly at all times. Suitable for smaller applications, where the workpiece cannot be held firmly. Complete with blade 150mm (6") 32tpi.



Overall Length	Weight per 50	Order Code KEN-538	Price/1 TB
260mm	6.40kg	-0600K	197.00

Spare Blade

Type	Length (mm)	TPI	Order Code KEN-040	Price TB
Metal	150	32	-0620K	67.00/10
Wood	150	14	-0640K	21.00/1

Mini Hand Saw - Comfort Grip

Plastic pistol grip with slip resistant grooves, spring steel frame. Complete with blade.

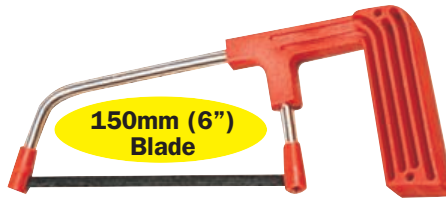

Overall Length	Weight per 12	Order Code KEN-538	Price/1 TB
216mm	1.20kg	-0620K	144.00

Tile Saw

Abrasive coated blade suitable for cutting intricate shapes, to allow flush fitting of tiles. Supplied with one blade.



Overall Length	Weight each	Order Code KEN-538	Price/1 TB
200mm	210g	-3600K	308.00

Spare Blades to suit above

Length (mm)	Pack Qty	Order Code KEN-040	Price/1 TB
150mm (6")	1	-1400K	155.00

Pad Saw

Heavy duty foam grip. Accepts 1/2" deep hacksaw blades. Suitable for use in areas of awkward access. **Blade length:** 145mm.



Overall Length	Weight each	Order Code KEN-538	Price/1 TB
275mm	130g	-1000K	225.00

Coping Saw

For cutting and shaping in wood. Steel frame and wooden handle. Supplied with 150mm (6") blade.

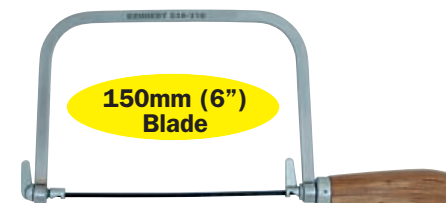

Overall Length	Weight each	Order Code KEN-538	Price/1 TB
290mm	200g	-2100K	608.00

Spare Blades to suit above

Length (mm)	TPI	Pk Qty	Order Code KEN-040	Price/Pk TB
150 (6")	14	10	-1020K	140.00

Low Profile Hacksaw

Manufactured from rigid and lightweight aluminium with hi-strength I-beam frame. Moulded 'soft touch' cushion grip. Features wing nut blade tensioning and 0° and 45° blade settings. Supplied with blade.



Overall Length	Weight per 5	Order Code KEN-538	Price/1 TB
400mm	2.75kg	-0800K	765.00

YAMOTO 6" Junior Hacksaw

Featuring an aluminium handle and tension adjustment screw, this junior hacksaw is supplied with a 150mm (6") general purpose blade.



Blade Length	Weight each	Order Code YMT-538	Price/1 TB
150mm		-0300K	232.00

6" Quick Release Junior Hacksaw

Featuring a quick release mechanism for fast and easy blade change, this hacksaw combines a robust design with a moulded handle. It comes supplied with a 150mm (6") general purpose blade.



Blade Length	Weight each	Order Code YMT-538	Price/1 TB
150mm		-0310K	258.00

SENATOR 6" Junior Hacksaw

Comprising a robust steel frame with finger guard, this lightweight hacksaw comes supplied with a 150mm (6") general purpose blade.



Blade Length	Order Code SEN-538	Price/1 TB
150mm	-0300K	205.00

HAND TOOLS

SENATOR *Hacksaw*
QUALITY TOOLING **Frame**

Lightweight body with wing nut blade tensioner. Suitable for light duty and workshop use. Supplied with blade.



Overall Length	Weight per 6	Order Code	Price/1 TB
440mm	3.10kg	SEN-538	717.00

Adjustable Hacksaw

Accepts 250/300mm (10"/12") blades. Suitable for light duty and workshop use. Supplied with blade.

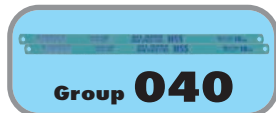

Overall Length	Weight each	Order Code	Price/1 TB
430mm	300g	SEN-538	361.00

10 - 12" Adjustable Hacksaw

A general purpose hacksaw, this Senator model with tension adjustment screw can be adjusted to hold a 250mm (10") or 300mm (12") blade. It comes supplied with a 300mm (12") general purpose blade.

NEW



Blade Length	Weight each	Order Code	Price/1 TB
440mm	3.10kg	SEN-538	284.00

KENNEDY *Hacksaw Frame & Blade Set*
QUALITY INDUSTRIAL TOOLING

250/300mm (10"/12") hacksaw frame with 10x 12" x 1/2" x 18 TPI HSS blades.



Contents	Weight each	Order Code	Price/1 TB
As above	850g	KEN-538	1288.00

2-Piece Hacksaw Set

Beaver style 150mm (6") junior hacksaw and 250/300mm (10"/12") adjustable hacksaw with wing nut tensioner.

2
PIECES



Contents	Weight each	Order Code	Price/1 TB
As above	850g	KEN-538	908.00

KENNEDY *Professional 'Plus' Hacksaw*
QUALITY INDUSTRIAL TOOLING

Heavy duty steel frame with front grip and 'D' style handle with grooved slip resistant rubber inlay for positive control and comfort. Wing nut and lever blade tensioning. The blade can be set at 45° to the frame to allow flush cutting. Supplied with blade.

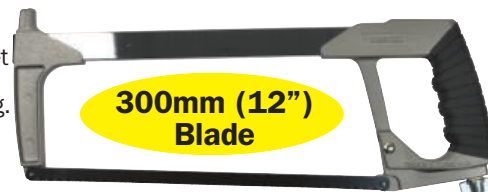

Overall Length	Weight per 5	Order Code	Price/1 TB
400mm	3.80kg	KEN-538	832.00

Adjustable Hacksaw

Die-cast 'D' style handle for user comfort and control. Epoxy coated tubular steel frame for strength and rigidity. The blade can be set at 90° to the frame to allow cutting in areas with restricted access. Wing nut blade tensioning. Accepts 250mm (10") and 300mm (12") blades. Supplied with blade.



Overall Length	Weight per 5	Order Code	Price/1 TB
475mm	3.20kg	KEN-538	743.00

Offset Hacksaw Frame

For use in awkward applications and for flush cutting. Heavy duty die-cast aluminium handle with a chrome plated, steel frame. Supplied with blade.



Reaches the parts other frames cannot reach . . .

Overall Length	Weight per 5	Order Code	Price/1 TB
300	2.10kg	KEN-538	608.00

YAMOTO *Lightweight Hacksaw Frame*

Strong and rigid construction frame with die-cast aluminium handle. Wing nut and lever blade tensioning allow easy blade replacement. The blade can be set at 90° for straight cuts and at 35° to the frame for flush cutting. Supplied with blade.



Overall Length	Weight per 5	Order Code	Price/1 TB
400mm	3.80kg	YMT-538	693.00

12" Comfort Grip Hacksaw

Combining robustness with comfort, this 12" (300mm) hacksaw features contoured handle, 45° and 90° blade positioning and tension adjustment screw. It comes supplied with a 300mm (12") general purpose blade.

NEW



Blade Length	Weight each	Order Code	Price/1 TB
300mm		YMT-538	773.00

HAND TOOLS

GROUP 539 CLAMPS



Lightweight Pressed Steel G-Clamps

Welded steel frame with chrome-plated steel screw, handle and swivel shoes. Suitable for light duty applications.



Capacity (mm)	Throat Depth	Weight each	Order Code KEN-539	Price/1 TB
Standard				
25	27	80g	-1970K	158.00
50	25	130g	-1980K	193.00
75	35	310g	-1990K	290.00
100	48	600g	-2000K	415.00
Deep				
63	66	360g	-2010K	252.00

Medium Duty G-Clamps

Engineer's clamps with cast anti-twist ribbed frame. For tradesmen, light engineering, woodworker's etc.



Capacity (mm)	Throat Depth	Weight each	Order Code KEN-539	Price/1 TB
75	40mm	0.75kg	-2730K	411.00
100	52mm	1.40kg	-2740K	514.00
150	82mm	2.00kg	-2760K	706.00

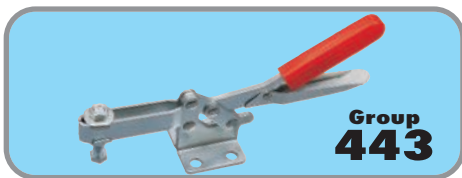

Heavy Duty G-Clamps

Manufactured from drop forged ribbed anti-twist frame steel suited to fabrication and other heavy applications, etc.



Capacity (mm)	Throat Depth	Weight each	Order Code KEN-539	Price/1 TB
50	33mm	0.35kg	-2020K	384.00
75	40mm	0.75kg	-2030K	493.00
100	52mm	1.40kg	-2040K	712.00
150	82mm	2.00kg	-2060K	1288.00
200	100mm	3.00kg	-2080K	1476.00
250	123mm	5.10kg	-2100K	3444.00
300	127mm	7.60kg	-2120K	3607.00

Extra Heavy Duty G-Clamps



Manufactured from drop forged steel ribbed anti-twist frame suited to fabrication and welding applications, etc.



Capacity (mm)	Throat Depth	Weight each	Order Code KEN-539	Price/1 TB
50	32mm	0.45kg	-2220K	443.00
75	43mm	0.70kg	-2230K	547.00
100	52mm	1.40kg	-2240K	717.00
150	72mm	1.90kg	-2260K	1427.00
200	110mm	4.50kg	-2280K	2077.00
250	123mm	6.00kg	-2300K	3028.00
300	130mm	9.00kg	-2320K	4405.00

Extra Heavy Duty G-Clamps - Copper Plate Screw

Manufactured from drop forged ribbed anti-twist frame steel suited to fabrication and welding applications, etc. Resistant to rusting and weld spatter.



Capacity (mm)	Throat Depth	Weight each	Order Code KEN-539	Price/1 TB
50	40mm	0.60kg	-2420K	499.00
75	50mm	0.70kg	-2430K	690.00
100	65mm	1.30kg	-2440K	936.00
150	90mm	3.00kg	-2460K	1591.00
200	110mm	4.50kg	-2480K	2143.00
250	130mm	5.90kg	-2500K	3588.00
300	150mm	9.10kg	-2520K	4466.00

Heavy Duty Deep Throat Clamps

Specialist clamp manufactured from drop forged steel, with extra throat depth for clamping workpieces further in from the edges, allowing a greater range of applications.



Capacity (mm)	Throat Depth	Weight each	Order Code KEN-539	Price/1 TB
50	60mm	460g	-2620K	541.00
75	80mm	955g	-2630K	862.00
100	115mm	2195g	-2640K	1200.00

Spare Shoes for Heavy, Medium Duty & Deep Throat G-Clamps



Shoe to fit (mm)	Weight each	Order Code KEN-567	Price/1 TB
50	10g	-5020K	67.00
75	15g	-5030K	67.00
100	30g	-5040K	78.00
150	40g	-5060K	155.00



Light Duty Cast G-Clamps

Light duty cast steel. Suitable for tradesmen, engineers, woodworkers etc.



Capacity	Weight each	Order Code SEN-539	Price/1 TB
50mm	195g	-1020K	163.00
100mm	675g	-1040K	352.00
150mm	1340g	-1060K	566.00



90° Welding Angle Clamp

One man set up and operation, made from cast iron, copper plated spindle for spatter protection, T-Handle enables high pressure for secure clamping, easy fixing to a work bench or machine tool table.



Capacity (mm)	Weight each	Order Code KEN-539	Price/1 TB
60mm	05.3kg	-0360K	2733.00
90mm	10.5kg	-0390K	3553.00

G-Clamp Adaptor

Acts as a 'third arm' allowing many clamping set-ups not normally possible without the use of additional or oversized clamps. Locates onto the cross-section of the clamp frame allowing clamping pressure to be applied between the clamp frame and the workpiece.

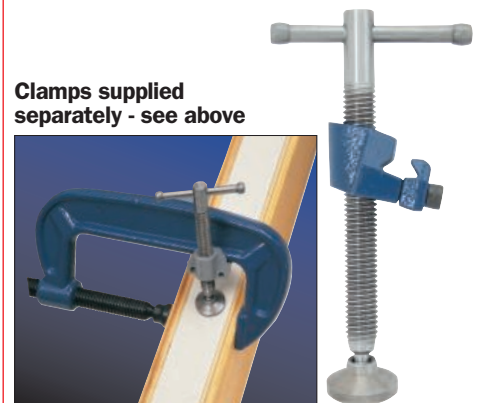

G-Clamp Adaptor	Weight each	Order Code KEN-539	Price/1 TB
95mm (3¾")	420g	-3590K	886.00

HAND TOOLS

KENNEDY *Spring Action Gripper Clamps*
QUALITY INDUSTRIAL TOOLING



Designed for speed and convenience. One hand operation gripping most materials. Durable non marking jaws pivot to hold irregular shaped workpieces. Contoured handle for non-slip grip with serrated jaws for extra firm holding.

Gripper Clamp Set

Spring loaded clamps, as above.

12 Piece Set Contents:

- 4x 120mm,
- 4x 150mm,
- 4x 210mm.



Provides a Third Hand

PACK OF 4



Number of Pieces	Weight	Order Code KEN-539	Price/1 TB
12	1564g	-5400K	747.00

Overall Length	Jaw Opening (max.)	Throat Depth	Weight per 4	Order Code KEN-539	Price/Pk TB
120mm	40mm	45mm	248g	-5300K	205.00
150mm	60mm	65mm	250g	-5320K	232.00
210mm	90mm	100mm	772g	-5340K	361.00

Sash Clamps

Used for a wide range of long reach clamping applications. SG ductile cast iron heads and slides, bars are manufactured from bright drawn steel. Main screw and handles are made from high grade steel.

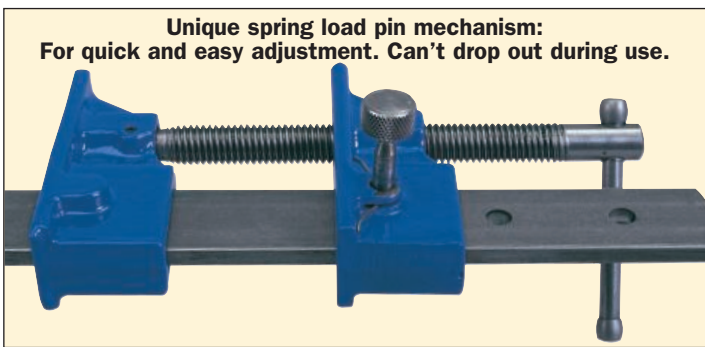

Unique spring load pin mechanism:
 For quick and easy adjustment. Can't drop out during use.

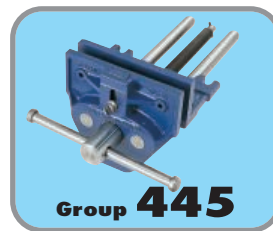

Group 445

High Grade Steel for Heavy Duty Applications

Capacity (mm)	Weight each	Order Code KEN-539	Price/1 TB
600	2.20kg	-3820K	2897.00
910	2.75kg	-3840K	3525.00
1220	3.25kg	-3860K	3745.00
1670	4.00kg	-3880K	3588.00

SENATOR *Lightweight Sash Clamps*
QUALITY TOOLING

Manufactured from high grade lightweight aluminium. Lever sprung quick adjust tail slide mechanism allows one-handed instant adjustment. Large 3" clamping pads help reduce footprint on the workpiece. Designed for clamping large work pieces during assembly.

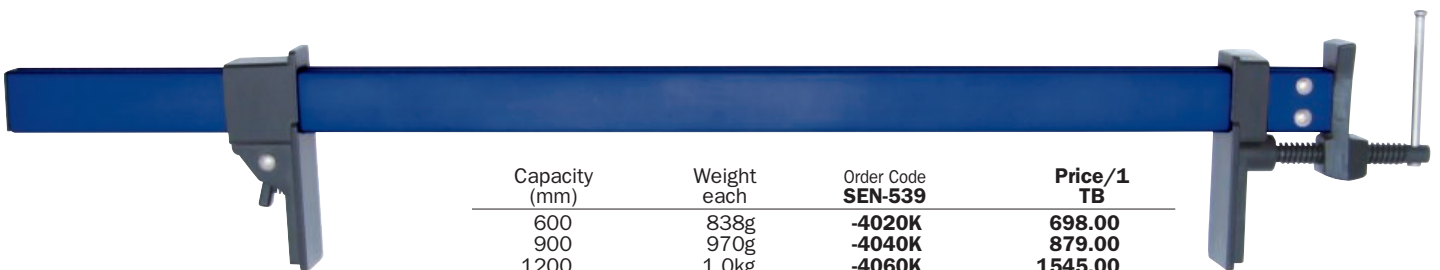

Capacity (mm)	Weight each	Order Code SEN-539	Price/1 TB
600	838g	-4020K	698.00
900	970g	-4040K	879.00
1200	1.0kg	-4060K	1545.00

PRODUCTS ARE ONLY AVAILABLE VIA YOUR DISTRIBUTOR

GROUP 539 CLAMPS

KENNEDY PROFESSIONAL

One Handed Quick Action Bar Clamps



Kennedy Professional Dual Action Quick Clamps are designed for use one handed for speed and convenience. The pistol grip handle houses a ratchet clamping mechanism that incrementally applies clamping force when you pull the trigger. To release or reposition the clamp jaw hold down the quick release button and slide the jaw along the bar. Can be used as a bar clamp or as a spreader simply by turning the handle around.

Features include: 90mm throat depth. Clamping force of up to 180kg. Quick release buttons for both jaws allows them to be positioned quickly anywhere on the bar and can be turned around to act as a spreader. Heavy duty steel bar. Non-slip clamp faces.



Head Release Button

Quick Release Lever

UP TO 180kg PRESSURE

2-IN-1 CLAMP OR SPREADER

Capacity (mm)	Spread Range (mm)	Clamping Force	Order Code KEN-539	Price/1 TB
175	190 - 425	180kg	-3330K	984.00
325	190 - 580	180kg	-3360K	1060.00
475	190 - 730	180kg	-3390K	1167.00
625	190 - 880	180kg	-3420K	1380.00
925	190 - 1125	180kg	-3450K	1698.00

SENATOR QUALITY TOOLING



One-Handed Speed Clamp

Manufactured from pressed steel for strength and durability. Trigger adjustment based on the sealant cartridge applicator gun.

Quick release thumb lever. High strength hexagonal steel thrust rod with swivel shoe for clamping non parallel surfaces. High strength plastic contact pads.



Capacity (mm)	Throat Depth (mm)	Order Code SEN-539	Price/1 TB
100	56	-5500K	389.00

HAND TOOLS

KENNEDY QUALITY INDUSTRIAL TOOLING

One-Handed, Quick Action Bar Clamps



Designed for speed and convenience with a comfortable ratchet handle design. The pistol grip handle allows you to hold the clamp and slide the jaw to work with one hand. Fitted with a quick release button and soft interchangeable pads which eliminate the need to find wood blocks to protect your work. Can be used as a bar clamp and can also convert into a spreader in seconds without the need for any other tools.



THROAT DEPTH 85mm

UP TO 90kg PRESSURE

2-IN-1 CLAMP OR SPREADER

Capacity (mm)	Spread Range (mm)	Clamping Force	Order Code KEN-539	Price/1 TB
150	120-350	90kg	-3060K	580.00
300	180-500	90kg	-3120K	634.00
450	180-650	90kg	-3180K	936.00
600	180-800	90kg	-3240K	1357.00



KENNEDY T-Handle Clamps
QUALITY INDUSTRIAL TOOLING

General purpose. Manufactured from medium heat treated carbon steel finished with nickel and chrome plating. Steel T-spindle for extra clamping force.

Quick Action



Capacity (mm)	Throat Depth (mm)	Order Code KEN-539	Price/1 TB
160	80	-0500K	949.00
200	100	-0520K	1170.00
250	110	-0540K	1251.00
300	110	-0560K	1829.00
400	110	-0580K	1892.00
500	110	-0600K	2080.00
600	110	-0620K	2331.00

Wooden Handle Speed Clamps

Manufactured from medium heat treated carbon steel with nickel and chrome plated finish. With a straight wooden handle for easy clamping.

Easy To Use



Capacity (mm)	Throat Depth (mm)	Order Code KEN-539	Price/1 TB
120	60	-0800K	761.00
160	80	-0820K	949.00
200	100	-0840K	1200.00
250	130	-0860K	1389.00
300	130	-0880K	1829.00
400	110	-0900K	1955.00
600	110	-0940K	2269.00

Heavy Duty T-Handle Clamps

Manufactured from heat treated carbon steel for extra strength. Finished with nickel and chrome plating. Textured T-spindle for extra clamping force.

Thicker Section For Greater Strength



Capacity (mm)	Throat Depth (mm)	Order Code KEN-539	Price/1 TB
150	60	-4200K	1515.00
200	100	-4220K	1955.00
300	100	-4280K	2048.00

Heavy Duty T-Handle Multi-Hold Clamps

Manufactured from heat treated carbon steel for extra strength. Finished with nickel and chrome plating. Textured T-spindle for extra clamping force. Supplied with three replaceable clamping pads for versatility.

Extremely Versatile



Capacity (mm)	Throat Depth (mm)	Order Code KEN-539	Price/1 TB
250	120	-4320K	3462.00
300	120	-4340K	4028.00
400	120	-4360K	4153.00
500	120	-4380K	4278.00
600	120	-4400K	4405.00

HAND TOOLS

GROUP 540 FLUID HANDLING

KENNEDY *Liquid Measures*
QUALITY INDUSTRIAL TOOLING

Chemical and oil resistant polyethylene liquid measures.

Graduations:

- ¼ltr - 10ml,
- ½ltr - 10ml,
- 1ltr - 10ml,
- 2ltr - 20ml,
- 3ltr - 50ml,
- 5ltr - 100ml.



Capacity	Weight each	Order Code KEN-540	Price/1 TB
¼ltr	45g	-5500K	258.00
½ltr	75g	-5520K	290.00
1ltr	100g	-5540K	296.00
2ltr	180g	-5560K	541.00
3ltr	260g	-5580K	824.00
5ltr	360g	-5600K	830.00

Heavy Duty Liquid Measures

Chemical and oil-resistant polyethylene liquid measures. Integral dispensing spout resistant to extreme weather conditions. Can be used in conjunction with dispensing spouts listed below.



Graduations:

- ½ltr - ¼ and ¼ltr,
- 1ltr - ¼, ½, ¾ltr,
- 2ltr - ½, 1, 1½ and 2ltr,
- 3ltr - 1, 1½, 2, 2½ and 3ltr,
- 5ltr - 1, 2, 3, 4 and 5ltr.

Capacity	Weight each	Order Code KEN-540	Price/1 TB
½ltr	60g	-5700K	195.00
1ltr	100g	-5720K	258.00
2ltr	180g	-5740K	315.00
3ltr	240g	-5760K	541.00
5ltr	340g	-5770K	573.00

Pouring Spouts

Flexible polyethylene, suitable for use with the spouted funnels and measures to allow for easy pouring in awkward areas.

Suitable For	Weight each	Order Code KEN-540	Price/1 TB
½ & 1ltr Measures	5g	-5160K	114.00
2, 3, & 5ltr Measures	15g	-5170K	132.00

Plastic Jerry Cans

Secure water containers manufactured from food grade plastic available in 10, 15 and 20ltr capacities, fitted with a collared screw top for ease of refilling and a twist on-off tap for spill free dispensing. The moulded handle design makes it ideal for transporting and storing water in and around the workplace, home or when travelling.



Capacity litre	Weight each	Order Code KEN-540	Price/1 TB
10	Water	-6500K	698.00
15	Water	-6520K	949.00
20	Water	-6540K	1075.00

Plastic Funnels

Resistant to oil and chemicals. Heavy duty polyethylene which will not shatter or break in cold weather.



Diameter (mm)	Weight each	Order Code KEN-540	Price/1 TB
50	4g	-2810K	89.00
75	9g	-2815K	95.00
100	20g	-2820K	100.00
120	32g	-2830K	107.00
150	50g	-2840K	120.00

Plastic Funnel Set

Contents: 50, 75, 100 and 125mm.



4 PIECES

Number of Pieces	Weight each	Order Code KEN-540	Price/1 TB
4	75g	-2890K	195.00

Heavy Duty Plastic Funnels

With anti-splash rims.



Diameter (mm)	Weight each	Order Code KEN-540	Price/1 TB
160	150g	-2910K	408.00
200	163g	-2920K	408.00
250	210g	-2930K	541.00
350	491g	-2940K	1765.00

Tin-Plated Oil Supply Cans

With easy pour handles for extra stability, extended spout with chain retained end cap and hinged lid cap.



Capacity litre	Weight each	Order Code KEN-540	Price/1 TB
3	562g	-2540K	1892.00
5	702g	-2560K	2133.00
10	1038g	-2580K	2207.00

Industrial Quality Plastic Funnel

Rectangular
Suitable for use with petrol, oil, water etc.



Size (mm)	Weight each	Order Code KEN-540	Price/1 TB
250 x 180	210g	-2900K	775.00

Tin-Plated Industrial Quality Funnels

Suitable for use with petrol, oil, water etc.



Diameter (mm)	Weight each	Order Code KEN-540	Price/1 TB
150	140g	-2600K	666.00
200	250g	-2800K	778.00

Offset Plastic Funnels

With anti-splash rims, removable brass filter, integral handle and rigid offset or 300mm detachable rigid spout. 160mm diameter.



EXTENDED RANGE

Spout Type	Weight each	Order Code KEN-540	Price/1 TB
Rigid	135g	-2960K	672.00
Flexible	135g	-2996K	199.00

Polyethylene Funnel with Lockable Lid

Screws into a standard 2" bung hole on a barrel. Includes a removable filter screen. Capacity 4.5 litres.

Size: 253mm x 200mm



NEW

Number of Pieces	Weight each	Order Code KEN-540	Price/1 TB
4	75g	-2680K	1250.00

Metal Funnel with Plastic Spout and Filter

Sturdy metal construction complete with integral handle for ease of use, plastic spout and removable filter. High rim design guards against splashing. Flexible spout extension also available (KEN-540-2700K).



NEW

Diameter (mm)	Weight each	Order Code KEN-540	Price/1 TB
150	140g	-2690K	850.00
200	250g	-2700K	399.00

HAND TOOLS

KENNEDY *Lever Pump*
QUALITY INDUSTRIAL TOOLING®

LP300
Zinc chrome finish steel, telescopic suction tube. Suitable for lubricants, diesel and non-corrosive liquids. Suitable for container sizes 60 and 200ltr. Tube length 480 - 900mm. Inlet on pump 2" BSP and M59 x 5 male thread.



Discharge per Stroke	Weight each	Order Code KEN-540	Price/1 TB
300ml	2.0kg	-3000K	2207.00

YAMOTO *Lever Pump*

Zinc-plated, self-adjusting telescopic suction tube. Comfortable lever grip. Suitable for lubricants and non-corrosive liquids. Suitable for container sizes 60 and 200ltr. Tube length 480 - 900mm. For use with BSP and metric threaded barrels.



Discharge per Stroke	Weight each	Order Code YMT-540	Price/1 TB
300ml	2.0kg	-3000K	1409.00

KENNEDY *Syphon Pump*
QUALITY INDUSTRIAL TOOLING®

Flexible plastic outlet and semi-rigid inlet tubes. Hand pumping units incorporate one-way valves. Suitable for use with petrol, diesel and non-corrosive liquids. All tubes can be cut to length.

SPS/25 For use with containers up to 25ltr. Fitted with 30mm bung.

Tube length: inlet 410mm/outlet 530mm.

SPS/205 For use with containers up to 205ltr. Fitted with a 50mm threaded bung.

Tube length: inlet 860mm/outlet 1000mm.

SPH/205 Heavy duty, for use with containers up to 205ltr. Fitted with a 50mm threaded bung.

Tube length: inlet 860mm/outlet 1000mm.



SPS/25 has a squeeze action. **SPS/205 & SPH/205** have a plunger type action.

Up to 25ltr



Up to 205ltr Heavy duty

Up to 205ltr

Model Number	Suitable for Containers	Weight each	Order Code KEN-540	Price/1 TB
SPS/25	25ltr	40g	-4000K	322.00
SPS/205	205ltr	80g	-4050K	1407.00
SPH/205	205ltr	420g	-4150K	1577.00

Piston Pump

PP190
Polypropylene pump with viton seals. Chemical resistant. Suitable for lubricants, fuels, solvents and non-corrosive liquids. Suitable for container size 200ltr. Tube length 480 - 900mm. Inlet on pump 2" BSP male and female thread.



Discharge per Stroke	Weight each	Order Code KEN-540	Price/1 TB
190ml	730g	-3250K	4091.00

Rotary Pump

RP250
Cast iron pump, steel suction tube and spout. Suitable for lubricants and diesel (not anti-freeze). Suitable for container size 200ltr. Tube length 980mm. Inlet on pump 2" BSP and M59 x 5 male thread.



Discharge per Stroke	Weight each	Order Code KEN-540	Price/1 TB
250ml 35ltr/min	5.7kg	-3100K	3147.00

Rotary Chemical Dispensing Pump

Designed for use with fluids which a regular cast iron or steel barrel pump cannot be used. Pump body is made from glass filled polypropylene with Ryton veins. Seals are from Vitron rubber and all hardware is stainless steel. Strainer fitted at the suction tube inlet stops contaminants. Threaded polypropylene suction tube and a choice of 2" bung adaptors for use on both plastic and metal drums of capacities 50ltr and 205ltr. For use with water-based fluids, anti-freeze, acids, chemicals etc., in addition to all petroleum-based products. Delivery 5ltr per 20 turns of the handle).

DO NOT USE with acetone, lacquer, mineral oils, solvents or turpentine.



Discharge per Stroke	Weight each	Order Code KEN-540	Price/1 TB
250ml	3kg	-3800K	4893.00

Double Diaphragm Fuel Transfer Pump

Heavy duty aluminium die-cast construction fuel transfer pump with a discharge rate of up to 1 gallon per 5 strokes (800ml per stroke). Stainless steel piston and fuel resistant hi-nitrile rubber diaphragm. 2" die cast bung adapter and extra heavy duty steel handle with security locking latch. Pump inlet is fitted with an easy to clean wire mesh screen filter.

Telescopic suction tube, adjustable to fit 50 to 205ltr drums, with non-return valve. Easy dispensing through 2.4m (8') of antistatic neoprene rubber hose with die-cast dispensing nozzle.

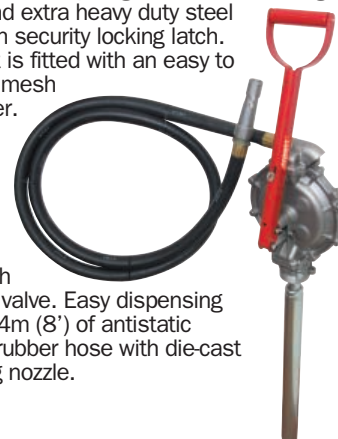

Discharge per Stroke	Weight each	Order Code KEN-540	Price/1 TB
800ml	7.5kg	-3600K	9373.00

Drum Taps

With 3/4" BSP male threads. Both models can be locked into the off position by use of a padlock or locking pin.

Polypropylene

Not suitable for petroleum-based products.

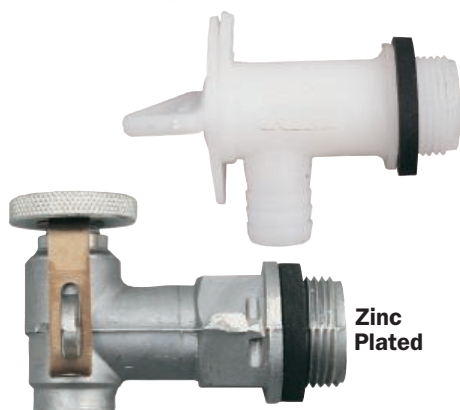

Type	Weight each	Order Code KEN-540	Price/1 TB
Zinc-Plated	300g	-9000K	1089.00
Polypropylene	100g	-9050K	277.00

HAND TOOLS

GROUP 540 FLUID HANDLING

KENNEDY *Dispensing Bottles*
QUALITY INDUSTRIAL TOOLING

Manufactured from oil and chemical resistant polyethylene. With rigid applicator nozzles and sealing caps.



60ml Concertina Pump Action Bottle

Capacity (ml)	Weight each	Order Code KEN-540	Price/1 TB
60	15g	-5000K	82.00

250ml Squeeze Bottle

Capacity (ml)	Weight each	Order Code KEN-540	Price/1 TB
250	40g	-5020K	100.00
500	60g	-5040K	226.00

With 25° Adjustable Brass Spout & Nozzle

Capacity (ml)	Spout Length	Weight each	Order Code KEN-540	Price/1 TB
125	90mm	40g	-5100K	307.00
250	150mm	55g	-5120K	333.00
500	190mm	70g	-5140K	376.00

Heavy Duty Trigger Hand Sprayers

Manufactured from polyethylene these robust trigger spray dispensers are suitable for many industrial applications, will dispense various chemicals, water-based detergents, solvents and cleaning agents.



Capacity (ml)	Type	Weight each	Order Code KEN-540	Price/1 TB
500	Industrial	79g	-5400K	88.00
740	Industrial	85g	-5420K	100.00
1000	Industrial	146g	-5440K	125.00

Dual Transfer Pump

DTP500

Heavy-duty aluminium construction. Durable inlet and outlet valves. Suitable for the transfer of many different liquid types. Portable and easy to operate. Ideal for use in many home, industrial and farm applications.

Capacity: 500cc.

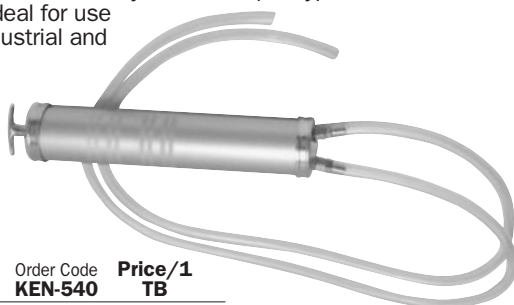

Capacity (cc)	Weight each	Order Code KEN-540	Price/1 TB
500	878g	-3400K	1075.00

Plastic Oil Cans

One-piece moulded plastic bodies with positive force feed pumps, supplied with nylon push-fit spouts.



Capacity (cc)	Spout Length	Weight each	Order Code KEN-540	Price/1 TB
350	150mm	110g	-1880K	698.00
500	150mm	120g	-1900K	824.00
1000	230mm	170g	-1920K	1012.00

'Snap' Bottom Oil Can

350ml traditional 'style' seamless metal oil can with enamel finish. Invert can and pop the bottom for an exact application. Supplied with 120mm rigid metal spout.

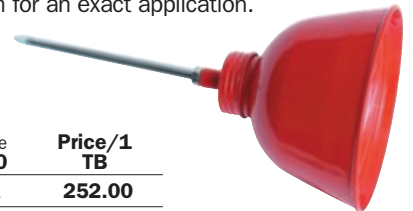

Capacity (ml)	Weight each	Order Code KEN-540	Price/1 TB
350	150g	-6200K	252.00

Metal Oil Cans

Enamel finish, heavy gauge, seamless metal-bodied oil cans. With positive force feed brass pumps and valves. Supplied with both rigid metal and flexible nylon threaded spouts.



Capacity (cc)	Weight per 10	Order Code KEN-540	Price/1 TB
125	2.20kg	-1120K	361.00
250	2.90kg	-1250K	372.00
350	3.20kg	-1350K	473.00
500	3.20kg	-1500K	508.00
750	3.67kg	-1750K	558.00
1000	4.16kg	-1100K	376.00

Spare Spouts to Suit (Interchangeable)

Type	Spout Length	Weight each	Order Code KEN-540	Price/1 TB
Flexible	150mm	170g	-1800K	59.00
	210mm	210g	-1850K	70.00

Oil Suction Gun

SG500

Chrome finish. Suitable for rapid draining or filling of oil and other non-corrosive liquids.



Working pressure: 90psi/6.2bar.
Diameter: 63mm.
Overall length: 330mm.

Capacity (cc)	Weight each	Order Code KEN-540	Price/1 TB
500	870g	-0380K	666.00

HAND TOOLS



KENNEDY *Pneumatic Fluid Extractor*
QUALITY INDUSTRIAL TOOLING

FEBK10

Pneumatic fluid extractor for use in draining engine oil, water, fuel and hydraulic fluids from vehicle engines and other mechanical equipment, bleeding brake/clutch fluid and collection of other non-corrosive fluid spillage. High capacity 10ltr fluid reservoir ideal for garage, extension tube storage, used for workshop and on-site use. Supplied with 1500 x 15mm initial tubing with extension tubes; 700 x 6mm, 360 x 10mm, 310 x 6mm and 380mm brake bleeder attachment. Air supply 70-110psi (5-8bar), air consumption 180ltr/min, vacuum (maximum) 500mm HG, extraction rate 2.5ltr/min., air inlet size 1/4" BSP.



Description	Weight each	Order Code KEN-540	Price/1 TB
Fluid Extractor	3.5kg	-4700K	10299.00

Mobile Waste Oil Drainer

ODB300

This sturdy mobile polyethylene container is for the collection of waste oil draining by gravity from engines/gearboxes. It has a capacity of 30ltr and a float level indicator to let you know when you are nearing its full capacity. The polyamide base is fitted with heavy-duty castors and a handle for easy manoeuvrability. The centre shaft is height adjustable from 900 to 1600mm with a 395mm diameter polypropylene drain pan, the pan is fitted with an anti-splash mesh.



Description	Weight each	Order Code KEN-540	Price/1 TB
Waste Oil Drainer	11.1kg	-4600K	11207.00

Tilting Drum Cradle

Tilting Drum Cradle tips, rotates and locates 205ltr drums.

- Equipped with removable handle
- Powder coated finish.
- Large 2 1/2" (63mm) non-sparking wheels making it suitable for use on rough flooring in gas/fuel plants.
- Maximum load 600lbs (273kg).
- Unit comes flat packed.

Dimensions (H x W x D):
90 x 830 x 510mm.



Description	Weight each	Order Code KEN-540	Price/1 TB
Tilting Drum Cradle	12.5kg	-4400K	6017.00

Direct Feed System

Lever Type LP12.5

Direct high pressure lubricating system with centre pump, metal dust cover/lid with integral stabiliser and fixing mechanism. Flexible delivery tube with offset nozzle. Suitable for medium greases.

Discharge per stroke: 3.8cm³,
Tube length: 375mm,
Inlet on pump max: 260mm.
Barrel (illustrated) available separately.



Description	Capacity (kg)	Weight each	Order Code KEN-540	Price/1 TB
Feed System	12.5	4.90kg	-0540K	8741.00
Barrel	12.5		-0580K	2108.00

High Pressure Grease Dispensing Pump

An easy to operate high pressure manual greasing system that is used to provide volume greasing where power is not available. Used for clean greasing of machinery, equipment and vehicles using grease up to and including NLGI 2. The pump has steel construction with aluminium cast head and solid steel pumping chamber. Complete with drum cover, follower plate, 1220mm (48") flexible grease hose fitted with professional 4-jaw coupler. For use with 12.5kg grease pails. Pump develops 3500psi (240bar) and delivers 1.25gm per stroke (1.2oz per 28 strokes).



Description	Weight each	Order Code KEN-540	Price/1 TB
Grease Dispensing Pump	4.8kg	-3640K	4869.00

Waste Oil Collection

These items are for the collection of waste oil prior to disposal in accordance with your local authority regulations.

Oil Drain Collector

This container is made of tough plastic, has an 8ltr capacity and can be closed for storage/transportation for disposal.

Oil Drain Pans

This waste oil pan is made of tough plastic and has an 8 or 16ltr capacity.



Type	Size	Shape	Weight each	Order Code KEN-540	Price/1 TB
Collector	8ltr	Square	1.13kg	-4500K	1288.00
Pan	8ltr	Round	1.14kg	-4520K	1075.00
Pan	16ltr	Round	5.30kg	-4540K	1200.00

GROUP 540 LUBRICATION EQUIPMENT

KENNEDY Grease Guns
QUALITY INDUSTRIAL TOOLING



Lever LG200

Chrome plated steel body, handle and offset nozzle. Suction fill. Suitable for medium/heavy greases.

Working pressure: 3000psi/206bar.
Diameter: 45mm.
Overall length: 300mm.

200cc



Capacity		Weight each	Order Code	Price/1 TB
Bulk Fill	Cartridge			
200cc		900g	-0150K	903.00

Lever LG400

Chrome-plated steel body, rubber grip and offset nozzle. Cartridge, bulk or suction fill. Suitable for medium/heavy greases.

Working pressure: 4500psi/310bar.
Diameter: 56mm.
Overall length: 370mm.

400cc

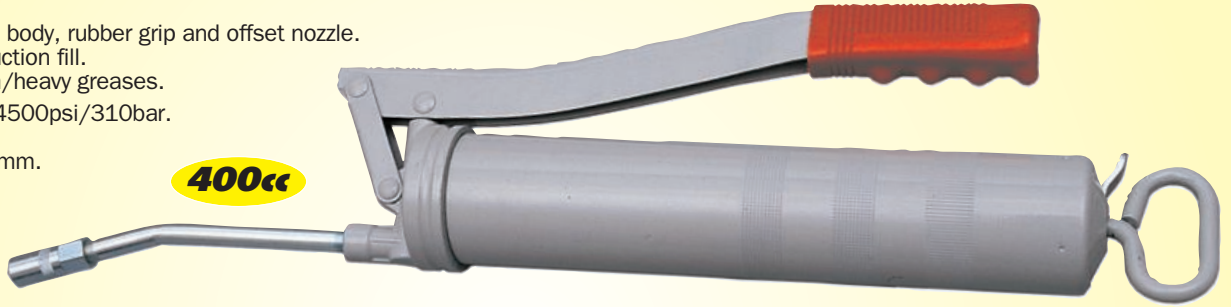

Capacity		Weight each	Order Code	Price/1 TB
Bulk Fill	Cartridge			
400cc	400g/14oz	1.35kg	-0250K	1176.00

Lever LG500

Chrome-plated steel body and handle, offset nozzle. Cartridge, bulk or suction fill. Suitable for medium/heavy greases.

Working pressure: 4500psi/310bar.
Diameter: 63mm.
Overall length: 352mm.

500cc

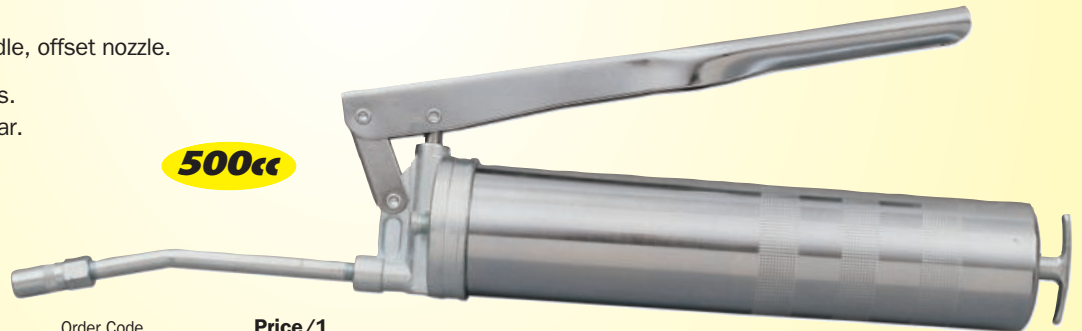

Capacity		Weight each	Order Code	Price/1 TB
Bulk Fill	Cartridge			
500cc	450g/16oz	1.50kg	-0300K	1197.00

Lever LG-PRO500

Enamel finish steel body, offset nozzle. Cartridge, bulk or suction fill. Suitable for medium greases.

Working pressure: 6000psi/400bar.
Diameter: 56mm.
Overall length: 340mm.

500cc



Capacity		Weight each	Order Code	Price/1 TB
Bulk Fill	Cartridge			
500cc	400g/14oz	1.80kg	-0340K	1526.00

YAMOTO Lever Type Grease Gun

Chrome-plated steel body, comfortable lever grip and offset nozzle. 14oz cartridge, bulk or suction fill. Suitable for medium/heavy greases.

Diameter: 56mm.
Overall length: 370mm.

400cc



Capacity		Weight each	Order Code	Price/1 TB
Bulk Fill	Cartridge			
400cc	400g/14oz	1.25kg	-0250K	693.00



HAND TOOLS



KENNEDY *Push-Type Grease Guns*
QUALITY INDUSTRIAL TOOLING

Robust metal body. Versatile one-hand operation. Supplied with universal nozzle connector for standard grease fittings.



Capacity (cc)	Weight each	Order Code KEN-540	Price/1 TB
35	258g	-0020K	384.00
140	436g	-0040K	493.00

Grease Gun

Pom-Pom PP100

Oil and acid resistant plastic body. Suction fill. Suitable for soft/medium greases.

Diameter: 35mm.
Overall length: 220mm.



100cc

Capacity (cc)	Weight each	Order Code KEN-540	Price/1 TB
100	140g	-0050K	575.00

YAMOTO *Steel Push-Type Grease Gun*

PTG1200

Bulk or suction fill. Corrosion protective electro-plated finish. Polished nozzle and galvanised plunger assembly. Suitable for medium or heavy greases.

Capacity (cc)	Weight each	Order Code YMT-540	Price/1 TB
120	415g	-0030K	568.00



120cc



Professional Grease Gun

Trigger TG120

Chrome-plated steel body, straight nozzle. Cartridge or suction fill. Suitable for soft/medium greases.

Working pressure: 2900psi/200bar.

Diameter: 36mm.

Overall length: 253mm.



120cc

Capacity Bulk Fill Cartridge	Weight each	Order Code KEN-540	Price/1 TB
120	760g	-0100K	794.00

Piston-Type Grease Gun

GGP120

Bulk or suction fill. Corrosion protective electro-plated finish. Galvanised plunger assembly. Suitable for medium or heavy greases.



120cc

Capacity Bulk Fill Cartridge	Weight each	Order Code YMT-540	Price/1 TB
120cc	505g	-0370K	568.00

Grease Guns

Trigger TG-PR0500

Enamel finish steel body, straight nozzle. Cartridge, bulk or suction fill. Suitable for medium greases.

Working pressure: 3900psi/260bar.

Diameter: 56mm.

Overall length: 340mm.



500cc

Capacity Bulk Fill Cartridge	Weight each	Order Code KEN-540	Price/1 TB
500cc	1.35kg	-0320K	1586.00

Steel Grease Gun

GGP400 - Pistol Type Grease Gun

400g (14oz) cartridge, bulk or suction fill. Galvanised trigger body. Galvanised nozzle and plunger assembly. Air bleed button. Comfortable grip. Suitable for medium or heavy greases.



400cc

Capacity Bulk Fill Cartridge	Weight each	Order Code YMT-540	Price/1 TB
400cc	1.50kg	-0360K	1029.00

Pneumatic Grease Gun

Pneumatic PG400

Chrome-plated steel body, enamel finish gun, offset nozzle. Cartridge, bulk or suction fill. For plant and factory maintenance, fleet service etc. Can be connected to air brake systems on lorries. Suitable for medium greases.

Working pressure: 3600psi/250bar.

Diameter: 56mm.

Overall length: 400mm.



400cc

Capacity (cc)	Weight each	Order Code KEN-540	Price/1 TB
400	1.90kg	-0360K	1577.00

PNEUMATIC

Pistol Type Adjustable Angle Pneumatic Grease Gun

PGC400

360° handle rotation. Continuous flow. Chrome plated steel body and enamel finish gun. Offset nozzle. Suitable for medium grease. 14oz cartridge - bulk, suction or pump fill. Can be connected to the air brake systems on lorries. 1200 - 6000psi based on 30 - 150psi feed.



400cc

Capacity (cc)	Weight each	Order Code KEN-540	Price/1 TB
400	1.88kg	-0350K	3525.00

PNEUMATIC

HAND TOOLS



Hydraulic Grease Nipple Kit

Contents

Straight:

1/4" BSP,
1/8" BSP,
M8 x 1.25
1/4" BSF.

45°:

M8 x 1.25
M10 x 1.50.

90°:

1/4" BSF.

**140
PIECES**



Description	Number of Pieces	Order Code KEN-541	Price/1 TB
Grease Nipple Kit	140	-5140K	1963.00

Flexible Hoses

For use with Kennedy grease guns, flexible hoses improve access in confined spaces, 1/8" BSP connecting threads.



Bore x Length	Type	Weight each	Order Code KEN-540	Price/1 TB
150mm	Offset Metal	40g	-0390K	125.00
8 x 230	Nylon	30g	-0400K	168.00
8 x 300	Nylon	40g	-0410K	192.00
8 x 500	Nylon	40g	-0420K	234.00
11 x 230	Rubber	60g	-0430K	272.00
11 x 300	Rubber	70g	-0440K	285.00
11 x 500	Rubber	90g	-0450K	359.00

Magnetic Pick-Up Tools

Slimline Handle

Telescopic with magnetic tip and contoured handle



Extended Length (mm)	Lifting Capacity	Weight each	Order Code KEN-553	Price/1 TB
550 (22")	1.8kg	50g	-0100K	454.00

Pen Type Handle

Telescopic with magnetic tip and pen type handle with pocket clip



Extended Length (mm)	Lifting Capacity	Weight each	Order Code KEN-553	Price/1 TB
650 (26")	1.8kg	40g	-0120K	155.00

Multi-directional Head

Magnetic tipped multi-directional head and pen type handle



Extended Length (mm)	Lifting Capacity	Weight each	Order Code KEN-553	Price/1 TB
580 (23")	680g	46g	-0140K	291.00

Flexible Shaft

Magnetic tipped with full adjustable shaft and weighted handle



Extended Length (mm)	Lifting Capacity	Weight each	Order Code KEN-553	Price/1 TB
455 (18")	500g	96g	-0130K	700.00

Hydraulic Grease Nipples

For use with Kennedy grease guns and all other hydraulic grease equipment.



Straight Hook-On

Thread Size	Weight Per 100	Order Code KEN-541	Price/1 TB
1/8" BSP(T)	1.30kg	-1070K	64.00
1/4" BSP(T)	2.00kg	-1090K	73.00

45° Type



Thread Size	Weight Per 100	Order Code KEN-541	Price/1 TB
1/8" BSP(T)	1.30kg	-0610K	46.00
1/4" BSP(T)	1.95kg	-0690K	82.00
1/4" BSF	0.70kg	-0770K	66.00
M6 x 1	0.70kg	-0850K	46.00
M8 x 1.25	0.60kg	-0930K	50.00
M10 x 1.5	1.25kg	-1010K	51.00

Straight Type



Thread Size	Weight Per 100	Order Code KEN-541	Price/1 TB
1/8" BSP(T)	0.60kg	-0600K	23.00
1/4" BSP(T)	1.10kg	-0680K	32.00
1/4" BSF	0.30kg	-0760K	28.00
M6 x 1	0.30kg	-0840K	23.00
M8 x 1.25	0.50kg	-0920K	23.00
M10 x 1.5	0.60kg	-1000K	28.00

90° Type



Thread Size	Weight Per 100	Order Code KEN-541	Price/1 TB
1/8" BSP(T)	1.30kg	-0630K	46.00
1/4" BSP(T)	2.10kg	-0710K	98.00
1/4" BSF	0.70kg	-0790K	60.00
M6 x 1	0.60kg	-0870K	54.00
M8 x 1.25	0.55kg	-0950K	51.00
M10 x 1.5	1.30kg	-1030K	60.00

Hydraulic Connectors

Securely grips the grease nipple while in use.

4-Jaw



Thread Size	Weight each	Order Code KEN-541	Price/1 TB
1/8" BSP(T)	40g	-0480K	157.00

Hook-On

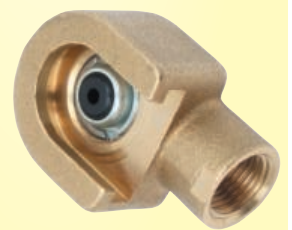

Thread Size	Weight each	Order Code KEN-541	Price/1 TB
1/8" BSP(T)	40g	-0490K	268.00



Magnetic Trays

For holding metal items such as nuts, bolts, washers etc.

Dish

For use in high and confined spaces with rubberised magnetic base mat to protect work surface.



Size (mm)	Weight each	Order Code	Price/1 TB
150 dia.	375g	-0250K	541.00

Rectangular Tray

For holding larger items.



Size (mm)	Weight each	Order Code	Price/1 TB
242 x 142	720g	-0300K	937.00

Magnetic Parts Tray

Rustproof stainless steel tray fitted with 4 x 85mm magnets in a non-marking cover which attaches to any ferrous surface. For retaining hand tools and fasteners, ideal for applications where nuts, bolts and parts could get lost preventing assembly. Suitable for automotive mechanics, appliance repairs and most applications within the service and repair industry.

Size: 295 x 270 x 42mm.



Bottom of tray

Size (mm)	Weight each	Order Code	Price/1 TB
295 x 270 x 42	1.60kg	-0270K	1666.00



Magnetic Vee Block

Ideal for holding cylindrical workpieces for grinding application. The adhesion will simultaneously hold the workpiece and vee-block to any flat ferrous surface.

Dimensions (W x L x H):
70 x 102 x 95mm.



Magnetic Adhesion	Weight each	Order Code	Price/1 TB
50kgf	4.00kg	-1100K	24762.00

Magnetic Link

Two magnetic units joined by an adjustable steel strap (82mm long). Capable of holding at many different angles.

Single link base dimensions (L x H x W):
60 x 30 x 25mm.

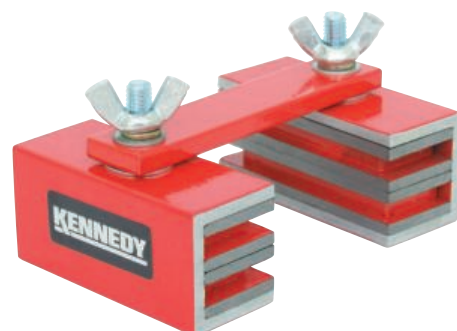

Magnetic Adhesion	Weight each	Order Code	Price/1 TB
13kgf	350g	-1400K	3089.00

Magnetic Pick-Up Wand

High power magnet for easy pick-up and release of metal objects. Can be used for scrap and ferrous debris. Permanent magnet, never needs to be re-magnetised. Lightweight. Chrome-plated and corrosion-resistant.

Lifting Capacity: 6.35kg.



Working Length	Weight each	Order Code	Price/1 TB
140mm	567g	-0200K	2163.00

MAGNETIC TOOLING

Magnetic Pick-Up Tool

High power magnet for easy pick-up and release of metal objects. Can be used for scrap and ferrous debris. Spring-loaded magnet release. Permanent magnet, never needs to be re-magnetised.

Lifting Capacity:
4.5kg.



Working Size	Weight each	Order Code	Price/1 TB
100mm dia.	634g	-0160K	629.00

Magnetic Long Reach

Long reach handle. High power magnet for easy pick-up and release of metal objects. Can be used for scrap and ferrous debris. Spring-loaded magnet release. Permanent magnet, never needs to be re-magnetised.

Lifting Capacity: 3.6kg.



Working Size	Weight each	Order Code	Price/1 TB
90mm Dia.	693g	-0180K	850.00

Magnet Extending Pick-Up Sweeper

High power magnet for easy pick-up and release of metal objects. Can be used for scrap and ferrous debris.

Lifting Capacity: 9.0kg.



Permanent magnet, never needs to be re-magnetised. Lightweight. Chrome-plated and corrosion-resistant.

Working Length	Weight each	Order Code	Price/1 TB
140cm	1430g	-0220K	2632.00

HAND TOOLS

GROUP 553 MAGNETIC TOOLING

KENNEDY *Magnetic Hold Fasts*
QUALITY INDUSTRIAL TOOLING

Positive gripping pot magnets supplied with screw-down release handle.
Can be used singly or in multiples for making welding or other jigs.
With M8 x 1.25 thread.
Depth: 35mm.



Diameter (mm)	Magnetic Adhesion	Weight each	Order Code KEN-554	Price/1 TB
40	20kgf	590g	-1200K	3462.00
50	40kgf	955g	-1240K	4797.00

Magnetic Quick Clamp

For fast accurate holding.

Dimensions: (width x length x thickness):
65 x 110 x 15mm.



Angles	Weight each	Order Code KEN-554	Price/1 TB
30°, 90° & 135°	270g	-1700K	573.00

Channel Magnet

Designed to give maximum grip within channels or slots. Able to grip non-uniform workpieces.



Length x Width x Height (mm)	Weight each	Order Code KEN-554	Price/1 TB
130 x 30 x 13	250g	-3500K	1645.00

Power Magnets

A square horseshoe magnet. Supplied with plain fixing holes.

Kg pull (max):
25mm - 4.5,
30mm - 9.0,
40mm - 11.8.



Size (mm)	Weight each	Order Code KEN-553	Price/1 TB
25 x 40 x 20	60g	-8120K	2059.00
30 x 45 x 30	120g	-8130K	1765.00
40.5 x 57 x 35	180g	-8140K	2457.00

Ferrite Shallow Pot Magnets

Manufactured from ceramic ferrite material set in a mild steel shell. Suitable for holding machine tool accessories with M6 threads or building into jigs.

Heavy Duty L-bolt



Ø x Width (mm)	Weight each	Order Code KEN-553	Price/1 TB
66 x 10.7	220g	-7020K	1029.00
76 x 12.5	300g	-7040K	1288.00
100 x 15.5	610g	-7060K	2733.00

J-bolt



Size (mm)	Weight each	Order Code KEN-553	Price/1 TB
46 x 10.7	90g	-8900K	402.00
56 x 10.7	130g	-8910K	439.00
66 x 10.7	190g	-8920K	446.00

Magnetic Chuck Blocks

For use with magnetic chucks that have parallel poles, so that the magnetic field can be extended to hold awkwardly shaped workpieces. Supplied in matched pairs. Machinable.



Width x Length x Height (mm)	Weight each	Order Code KEN-400	Price/Pr TB
60 x 75 x 30	1.50kg	-2500K	2678.00

Bar Magnets

A range of one-piece cylindrical magnets with opposing poles at either end. Permanently magnetic.



Dia. (mm)	Depth (mm)	Weight Per 100	Order Code KEN-553	Price/1 TB
6.0	20 (3/4")	0.44kg	-8050K	199.00
8.0	25 (1")	1.00kg	-8060K	292.00
10.0	30 (1 3/16")	1.90kg	-8070K	186.00

Button Magnets

A horseshoe type cylindrical magnet. Opposing poles are at the same end of the magnet separated by a slot. Supplied with a plain bore and keeper. Permanently magnetic.



Diameter (mm)	Depth (mm)	Weight Per 100	Order Code KEN-553	Price/1 TB
12.7 (1/2")	9.5	0.87kg	-8210K	210.00
20 (3/4")	12.5	2.00kg	-8220K	308.00
25 (1")	16.0	5.60kg	-8230K	486.00
32 (1 1/4")	19.5	13.0kg	-8240K	567.00

Shallow Pot Magnets

North polarity in centre separated from opposing pole by a continuous slot. For use in areas of restricted height. Supplied with plain bore fixing hole and keeper. Permanently magnetic.



Diameter (mm)	Depth (mm)	Weight Per 100	Order Code KEN-553	Price/1 TB
20 (3/4")	7.8	1.75kg	-8260K	386.00
28.5 (1 1/8")	8.7	4.70kg	-8270K	509.00
38 (1 1/2")	10.6	9.70kg	-8280K	593.00

Deep Pot Magnets

North polarity in centre separated from opposing pole by a continuous slot. Ideally suited for gripping applications. Supplied with M5 x 1 threaded bore fixing hole and keeper. *M3 x 0.5.



Diameter (mm)	Depth (mm)	Weight Per 100	Order Code KEN-553	Price/1 TB
9.5 (3/8")*	15.1	2.00kg	-8290K	140.00
17.5 (11/16")	16.0	2.70kg	-8310K	167.00
20 (3/4")	18.0	4.50kg	-8320K	444.00
27 (1 1/16")	25.4	9.80kg	-8330K	486.00
35 (1 3/8")	30.0	28.9kg	-8340K	811.00

Set

2 each: 12.7mm button.
1 each: 17.5mm deep button,
20mm button and 20mm pot.

**5
PIECES**

Number of Pieces	Weight each	Order Code KEN-553	Price/1 TB
5	90g	-9000K	752.00

HAND TOOLS



Quick-Set Torque Drivers

1/4 Micrometer style adjustment allows easy accurate setting. Slipping action at pre-set torque eliminates overtightening. The adjustment ring automatically disengages when the tool is in use to prevent accidental adjustment. Stainless steel shafts. Anodised aluminium handles. Suitable for electrical, electronics and instrument assembly works. Manufactured to **ISO 6789 : 2003. (Accuracy ±6% of reading).**

Minor Type



Product Number	Torque Range		Weight each	Order Code KEN-555	Price/1 TB
	cNm	ozf.in			
QS1.2MH	20 - 120	-	165g	-5010K	13761.00
QS1.2IH	-	20 - 120	165g	-5020K	13761.00

Standard Type

1/4 Can be used with 1/4" hexagon drive. Sliding 'T' bar supplied.



Product Number	Torque Range		Weight each	Order Code KEN-555	Price/1 TB
	Nm	lbf.in			
QS6MH	1 - 6	-	335g	-5600K	14935.00
QS50IH	-	5 - 50	335g	-5500K	14935.00

Torque Limiting Screwdrivers

L" A/F female hexagon socket which will accept screwdriver bits. Can be converted to a male end by using the appropriate adaptor. Can be pre-set to any torque value within range by using a Torque Calibration Analyser. Can be fitted with 'impact-free resetting' option. Manufactured to **ISO 6789 : 2003. (Repeatability at ±6% of set torque).**

LS135H



LS406H



Product Number	Torque Range		Weight each	Order Code KEN-555	Price/1 TB
	cNm	lbf.in			
LS135H	2 - 135	12	200g	-5700K	8601.00
LS406H	6 - 406	36	300g	-5800K	8755.00

Pre-setable Torque Breaking Handle - Spigot Type

Handle 'breaks' at an angle of 20° and features a unique patented single direction mechanism, ensuring long tool life and repeatable accuracy. Fitted with the new mechanical torque adjustment locking device. Automatically resets when force is released and returns to the in-line position. Manufactured to **ISO 6789 : 2003. (Repeatability at ±4% of reading tools above 10Nm and ±6% for tools less than 10Nm).**

Overall length: 265mm.



Mechanical Torque Adjustment Locking Device

- Easy-to-use locking device for the torque adjusting screws.
- Does not rely on friction to arrest movement.
- Operated using a single adjusting key.



Group 581

Compatible with the Norbar® 16mm Spigot End fittings.

Product Number	Torque Range		Spigot Size	Weight each	Order Code KEN-555	Price/1 TB
	Nm	lbf.in				
BH25	5.0-25	44-221	16mm	415g	-5900K	15450.00

Dial Indicating Torque Drivers

Can indicate torque in two ways - measures and displays torque as it is applied, or measures and displays the maximum torque used, after it has been applied. Ideal for the electronics, electrical and domestic appliance industries. Stainless steel shafts coloured aluminium handles and scaled nylon dials. 1/4" hex drive. Dual scale. Manufactured to **ISO 6789 : 2003. (Accuracy ±6% of reading).**



Minor Type 1/4

Product Number	Torque Range		Weight each	Order Code KEN-555	Price/1 TB
	cNm	ozf.in			
S50H	10 - 50	14 - 70	190g	-8050K	12811.00
S100H	20 - 100	28 - 140	190g	-8100K	12201.00

Standard Type

Can be used with 1/4" drive. Sliding 'T' bar supplied.



Product Number	Torque Range		Weight each	Order Code KEN-555	Price/1 TB
	cNm	lbf.in			
S250H	50 - 250	4 - 20	465g	-8250K	13450.00
S500H	100 - 500	8 - 40	465g	-8500K	12683.00

1/4" Square Drive Slipper Wrenches

1/4 Micrometer style fine adjustment with positive locking system. Automatic resetting with audible click when the wrench slips. Accurate repeatability. Aircraft specification stainless steel heads, aluminium handles. Designed to operate in any environment from the toughest engineering production line to fine finish assembly areas. Manufactured to **ISO 6789 : 2003.**



Product Number	Torque Range		Weight each	Order Code KEN-555	Price/1 TB
	Nm	Increment			
TCW5	1 - 5	0.05Nm	235g	-7050K	16776.00
TCW10	2 - 10	0.10Nm	235g	-7100K	17020.00

Production Slipper Torque Wrenches

Wrench 'slips' when predetermined torque setting is reached, completely eliminating overtightening. Fitted with Mechanical Torque Adjustment Locking Device. Accurate repeatability guarantees equal tightness every time. Incorporates a specially designed multi-lobed cam which automatically resets the wrench after a small movement of the handle, allowing quick progress to the next operation. Incorporates a fully supported ratchet giving smooth, positive torque control, even in confined spaces. Lightweight for less operator fatigue. Manufactured to **ISO 6789 : 2003. (Repeatability at ±4% of reading).**



Mechanical Torque Adjustment Locking Device

- Easy-to-use locking device for the torque adjusting screws.
- Positive, mechanical locking system.
- Does not rely on friction to arrest movement.
- Operated using a single adjusting key.



Product Number	Torque Range		Length (mm)	Ratchet Size	Order Code KEN-555	Price/1 TB
	Nm	lbf/ft				
MPW125	40 - 125	30 - 90	460	1/2"	-4000K	28183.00
SPW25	3 - 25	2 - 18	216	3/8"	-4050K	21991.00
SPW55	15 - 55	10 - 40	325	3/8"	-4070K	23791.00
TPW25	3 - 25	2 - 18	216	1/4"	-4100K	21368.00

GROUP 555 TORQUE TOOLS

SENATOR Square Drive Torque Wrenches

Reversible ratchet head. 'Click + Snap' action indicates when the pre-set torque level has been reached. Engraved kgf.m and Nm scale on barrel. Micrometer type sleeve allows preset torque values to be accurately set. Manufactured to **ISO 6789:2003 (BS EN 26789:2003)**

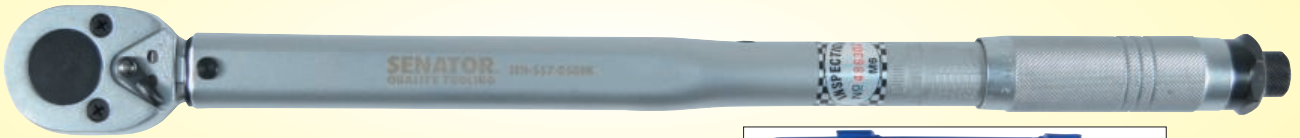

1/4 3/8 1/2

Overall Length	Sq. Drive	Torque Range		Order Code	Price/1 TB
		Nm	kgf.m		
280mm	1/4"	9-25	0.25-2.5	-0300K	2300.00
365mm	3/8"	19-110	1.9-11.2	-0400K	2400.00
440mm	1/2"	42-210	4.2-21.4	-0500K	2553.00

EXTENDED RANGE



TRI TORQ Adjustable Torque Wrench

Manufactured from high quality satin finish steel with a polished steel head. Supplied with a fully traceable calibration certificate and storage case. The desired torque value can be set, and is displayed in windows on the handle. Manufactured to **BS EN 26789 : 1994 and Federal GGG-W-686 standards.**



Supplied in Robust Storage Case



1/4 3/8 1/2

Model Number	Square Drive	Torque Range		Weight each	Order Code	Price/1 TB
		Nm	lbf.ft			
FXL5	1/4"	1 - 5	0.7 - 3	0.40kg	-5740K	3708.00
FXL32	1/4"	6 - 30	4 - 22	0.40kg	-5760K	3708.00
FXL33	3/8"	6 - 30	4 - 22	0.40kg	-5850K	3863.00
FXL63	3/8"	12 - 60	7 - 44	1.30kg	-5870K	3863.00
FXL100	3/8"	20 - 100	15 - 75	1.38kg	-5900K	3966.00
FXL200	1/2"	40 - 200	30 - 150	2.36kg	-6900K	4858.00
FXL320	1/2"	60 - 320	45 - 225	2.57kg	-6920K	6503.00

With Factory Tested Calibration Certificate

Ratchet Repair Kits

To Suit	Order Code	Price/1 TB
	TRQ-567	
FXL100	-5900K	464.00
FXL200/FXL320	-6900K	1029.00

HAND TOOLS

KENNEDY Adjustable Torque Wrenches

To From	International System S.I.			Inch			Metric		
	mNm	cNm	Nm	Ozf.in	lbf.in	lbf.ft	gf.cm	kgf.cm	kgf.m
mNm	1	0.1	0.001	0.142	0.009	0.0007	10.2	0.01	0.0001
cNm	10	1	0.01	1.416	0.088	0.007	102	0.102	0.001
Nm	1000	100	1	141.6	8.851	0.738	10197	10.20	0.102
Ozf.in	7.062	0.706	0.007	1	0.0625	0.005	72	0.072	0.0007
lbf.in	113	11.3	0.113	16	1	0.083	1152.1	1.152	0.0115
lbf.ft	1356	135.6	1.356	192	12	1	13826	13.83	0.138
gf.cm	0.098	0.01	0.0001	0.014	0.0009	0.00007	1	0.001	0.00001
kgf.cm	98.07	9.807	0.098	13.89	0.868	0.072	1000	1	0.01
kgf.m	9807	980.7	9.807	1389	86.8	0.7233	100000	100	1

EXAMPLE: To convert 10 lbf.ft to Nm, read across (units to be converted from) and down (units to be converted to) as shown above to obtain

Torque Conversion Factor.

Number of Units to be Converted x Conversion Factor = Total Converted Units
i.e: 10 lbf.ft x 1.356 = 13.56 Nm

Note: The unit Kilogramme Force (kgf.m) is also known as Kilopond (kp.m), 1kgf.m=1kp.m

With Factory Tested Calibration Certificate

High quality chrome-plated, polished steel head and retractable torque setting lever. 'Click and Snap' action indicates when the pre-set torque level has been reached. Four easy read scales Nm, kgf.m, lbf.in x10, lbf.ft. Push through square drive connector to instantly reverse action. Knurled grip plastic handle. Complete with factory tested calibration certificate, operating instructions and torque conversion chart. Supplied in a cardboard case. Manufactured to **ISO 6789 : 2003 (BS EN 26789 : 2003)**. Accuracy = ±4%.



Replacement Squares for Torque Wrenches

Model Number	Square Drive	Torque Range		Length (mm)	Order Code	Price/1 TB
		Nm	lbf.ft			
FTW011	3/8"	2.5 - 11	2 - 8	300	-3500K	6999.00
FTW033	3/8"	5.0 - 33	3 - 24	410	-3520K	7100.00
FTW068	3/8"	12.0 - 68	9 - 50	480	-3540K	7500.00
FTW150	1/2"	25 - 135	20 - 100	560	-3560K	8750.00
FTW250	1/2"	50 - 200	40 - 145	610	-3580K	9250.00
FTW350	1/2"	70 - 330	50 - 240	780	-3600K	10850.00
FTW800	3/4"	200 - 810	145 - 580	940	-3610K	25000.00

Square Drive	To Suit	Order Code	Price/1 TB
3/8"	-0400K	-3100K	603.00
	-0420K		
	-0440K		
1/2"	-0500K	-3200K	1886.00
	-0520K		
1/2"	-0540K	-3250K	1226.00
	-0560K		
3/4"	-0620K	-3300K	1886.00



Dial Indicating Torque Wrenches

Ideal for use in inspection and quality control, research and development, production and after sales service. Lightweight aluminium handles, abrasive resistant bodies for longer life and easy read dual scale for observing the amount of torque applied throughout the tightening process. Socket not included. Manufactured to **ISO 6789 : 2003. (Accuracy ±4% of reading).**

1/4" Square Drive Not suitable for use with extensions.



Product Number	Torque Range		Weight each	Order Code KEN-555	Price/1 TB
	Nm	lbf.in			
TW4	0.8 - 4.0	7 - 35	520g	-1040K	21472.00
TW12	2.4 - 12	24 - 120	520g	-1120K	22000.00

3/8" Square Drive (not illustrated)

Product Number	Torque Range		Weight each	Order Code KEN-555	Price/1 TB
	Nm	lbf.in			
SW25	5 - 25	48 - 240	520g	-1250K	20168.00
SW40	8 - 40	72 - 360	520g	-1400K	23878.00

1/2" Square Drive

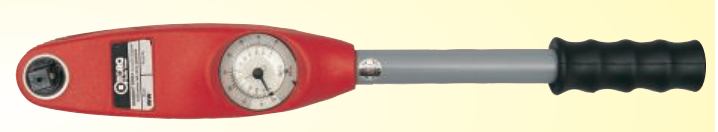

Product Number	Torque Range		Weight each	Order Code KEN-555	Price/1 TB
	Nm	lbf.ft			
MW80	16 - 80	12 - 60	1.35kg	-2080K	32659.00
MW200	40 - 200	30 - 160	1.40kg	-2200K	33000.00

3/4" Square Drive With built-in audio/visual signal.

Product Number	Torque Range		Weight each	Order Code KEN-555	Price/1 TB
	Nm	lbf.ft			
LW800	160 - 800	120 - 660	4.85kg	-3800K	61601.00



Torque Calibration Analyser



Clear easy to use scales. Specifically designed to set and calibrate most makes of torque tools. Mechanism is totally enclosed in a die-cast aluminium housing. Repeatable accuracy to ±2% of reading. Memory pointer and built-in needle shock absorber. Single direction mechanism for clockwise use. The preferred and certified ranges of these torque calibration analysers meet the specified measuring range as detailed in **ISO 6789 : 2003.**



With Factory Tested Calibration Certificate

ISO (Nm)	Torque Range		Scale Sub Divisions	Order Code KEN-555	Price/1 TB
	lbf.in				
5.0 - 25	44 - 220	0.5Nm/5lbf.in	-6700K	44805.00	



Torque Multipliers

Ideal for applications where no electrical or air supply is available. Enables precision tightening of threaded fasteners. Aids the loosening of nuts that are corroded or seized. Accurate to within ±4%, taking the uncertainty out of high torque tightening.

TN14: Input: 1/2" sq. drive. Output: 3/4" sq. drive.

TN27: Input: 3/4" sq. drive. Output: 1" sq. drive.

NEW



6:1 - Maximum Torque 1680Nm



5.4:1 - Maximum Torque 2700Nm

Product Number	Maximum Torque	Weight each	Order Code KEN-557	Price/1 TB
TN14	1500Nm	6.1kg	-3620K	28000.00
TN27	2700Nm	7.3kg	-3630K	31000.00

Replacement Square Drives

Square Size	To Suit	Order Code KEN-567	Price/1 TB
3/4"	TN14	-9300K	4271.00
1"	TN27	-9400K	5187.00



Angular Torque Gauge



The gauge has an easy to read 360° scale in 2°, 10° and 30° increments and has an Indicator etched into the clear plastic. An adjustable arm to keep the angled scale stationary, with a long and short side for flexibility in positioning against components.



1/2"

Product Number	Capacity Nm	Weight each	Order Code KEN-557	Price/1 TB
TGA360	0 - 360	180g	-0150K	931.00

Nut Spinners

Manufactured from hardened and tempered chrome vanadium steel, with satin chrome finish. Oil and acid resistant high impact plastic handles. 6" (150mm) combined socket and blade length. **Overall length: 230mm.**



Type	Hexagon AF	Order Code KEN-556	Price/1 TB
Metric	4.0mm	-7400K	250.00
	4.5mm	-7450K	255.00
	5.0mm	-7500K	357.00
	5.5mm	-7550K	362.00
	6.0mm	-7600K	372.00
	7.0mm	-7700K	400.00
	8.0mm	-7800K	410.00
	9.0mm	-7900K	433.00
	10.0mm	-8100K	443.00
	BA	0BA (.413")	-1200K
1BA (.365")		-1210K	178.00
2BA (.324")		-1220K	184.00
3BA (.282")		-1230K	189.00
4BA (.248")		-1240K	196.00
5BA (.220")		-1250K	202.00
	6BA (.193")	-1260K	214.00

Sets

Number of Pieces	Contents	Order Code KEN-556	Price/Set TB
7	0, 1, 2, 3, 4 & 6BA	-9520K	1203.00
9	4, 4.5, 5, 5.5, 6, 7, 8, 9 & 10mm	-9620K	2290.00



HAND TOOLS

GROUP 558 PLIERS & GRIPS

KENNEDY PROFESSIONAL Pro-Torq Groove Waterpump Pliers



Double polished head and joint with hardened steel jaws. The dual material grip handle manufactured with a polypropylene core for strength and durability with a soft thermoplastic outer for non-slip comfort grip. Ideal for environments where repetitive work is undertaken. Joint protector stops the handles closing together, preventing trapped fingers.



DUAL MATERIAL HANDLES

Overall Length	Jaw Opening	Weight each	Order Code	Price/1 TB
265mm (10½")	45mm	420g	KEN-558	1041.00

KENNEDY QUALITY INDUSTRIAL TOOLING Box Joint Waterpump Pliers



The slip joint head design prevent the pliers from twisting when pressure is applied. Hardened steel, ground jaws, sliding pivot joint for a wide range of jaw openings. Satin finish. The joint protector stops the handles closing together, preventing trapped fingers. Bonded anti slip vinyl grips



Overall Length	Jaw Opening	Weight each	Order Code	Price/1 TB
255mm (10")	35mm	283g	-3660K	1157.00

Groove Joint Waterpump Pliers

Hardened chromed steel jaws. Sliding pivot joint allows the widest range of jaw openings. The handles cannot be closed together, preventing trapped fingers.



Overall Length	Jaw Opening	Weight each	Order Code	Price/1 TB
190mm (7½")	30mm	280g	-3670K	715.00
255mm (10")	45mm	400g	-3680K	876.00
320mm (12½")	55mm	425g	-3700K	1405.00
405mm (16")	100mm	580g	-3710K	2059.00

Plastic Pipe Gripping Pliers

Ideal for screwing and unscrewing plastic pipe joints, round union nuts etc. up to 65mm diameter 4-position adjustable slip joint. Serrated gripping jaws with removable plastic jaw covers. Manufactured from chrome vanadium electric steel, oil-hardened and tempered with bonded vinyl grip for improved comfort and control.



Overall Length	Weight each	Order Code	Price/1 TB
233mm (9")	295g	-4100K	439.00
Spare Jaws (Pair)	-	KEN-567-3750K	37.00

KENNEDY QUALITY INDUSTRIAL TOOLING Spring-Loaded Soft Touch Slip Joint Waterpump Pliers



Manufactured from hardened and tempered chrome vanadium steel with corrosion-resistant chemically blacked finish. Vinyl grip for improved comfort and control. Replaceable soft grip plastic inserts allow delicate or finished components to be gripped without damage. Eight position groove with spring-loaded rapid jaw adjustment.

Overall length: 250mm.
Capacity: 40mm.



Overall Length	Weight each	Order Code	Price/1 TB
250mm (10")	400g	-8920K	692.00
Soft Jaws To Suit Above	5g	-8930K	61.00

YAMOTO INDUSTRIAL PLIERS Slip Joint Waterpump Pliers



Industrial quality chrome vanadium steel, chemically blacked. With a sliding pivot to give a wide range of jaw openings. Bi-material grips.

DUAL MATERIAL HANDLES



Overall Length	Weight each	Order Code	Price/1 TB
250mm	380g	-4660K	541.00

SENATOR QUALITY TOOLING Groove Joint Waterpump Pliers



Manufactured from chrome vanadium steel with a satin finish. Textured grip handles for improved comfort and control. Groove joint for quick adjustment with serrated jaws for extra grip.



Overall Length	Weight each	Order Code	Price/1 TB
200mm (8")	275g	-4670K	263.00
255mm (10")	385g	-4680K	552.00
305mm (12")	415g	-4700K	578.00
420mm (16½")	570g	-4710K	1391.00

Box Joint Waterpump Pliers

Chrome vanadium steel with bonded vinyl coated handles.
Overall length: 255mm (10").



Overall Length	Weight each	Order Code	Price/1 TB
255mm (10")	400g	-4660K	289.00

HAND TOOLS

KENNEDY 3-Piece Professional Quality Chrome Vanadium Plier Sets



Contents	Product Number	Weight each	Order Code KEN-558	Price/1 TB
Adjustable Wrench 150mm	501-106			
Diagonal Cutters 160mm	558-332	490g	-9820K	2072.00
Combination 160mm	558-353			



Contents	Product Number	Weight each	Order Code KEN-558	Price/1 TB
Snipe Nose 160mm	558-321			
Diagonal Cutters 160mm	558-332	490g	-9830K	2559.00
Combination 160mm	558-352			



Contents	Product Number	Weight each	Order Code KEN-558	Price/1 TB
Adjustable Wrench 205mm	501-108			
Groove Joint 190mm	558-367	840g	-9810K	2772.00
Combination 180mm	558-346			

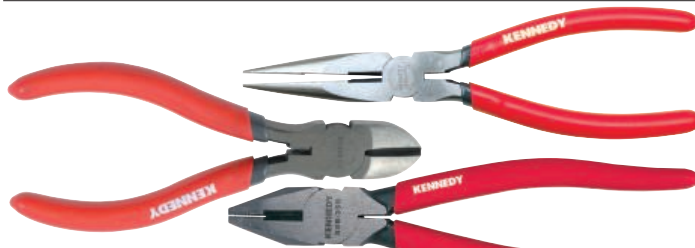

Contents	Product Number	Weight each	Order Code KEN-558	Price/1 TB
Snipe Nose 205mm	558-323			
Diagonal Cutters 180mm	558-333	830g	-9850K	1894.00
Linesman Combi 205mm	558-358			

Heavy Duty



Contents	Product Number	Weight each	Order Code KEN-558	Price/1 TB
Groove Joint 255mm	558-368			
Diagonal Cutters 180mm	558-433	1000g	-9840K	2609.00
Combination 160mm	558-454			

KENNEDY PROFESSIONAL Pro-Torq Comfort Grip Plier Sets



Manufactured from specially selected steels. The dual material grip handle design allows the user to apply the greatest force with the minimum amount of effort. Manufactured with a polypropylene core for strength and durability with a soft thermoplastic outer for non-slip comfort grip. Especially suitable for production line environments where repetitive work is undertaken.



Number of Pieces	Contents	Weight each	Order Code KEN-558	Price/1 TB
3	Snipe Nose 165mm Diagonal Nippers 140mm Combination Pliers 165mm	0.65kg	-7000K	1531.00
4	Groove Joint 265mm Snipe Nose 215mm Diagonal Nippers 165mm Combination Pliers 200mm	1.45kg	-7020K	2651.00

YAMOTO Chrome Vanadium Plier & Wrench Sets



Manufactured from industrial quality chrome vanadium steel, chemically blacked with laser etched markings and bi-material grips.

3-Piece Plier & Wrench Set



Number of Pieces	Contents	Order Code YMT-558	Price/1 TB
3	Waterpump Plier 250mm Combination Plier 185mm Adjustable Wrench 150mm	-9810K	1195.00

3-Piece Plier Sets

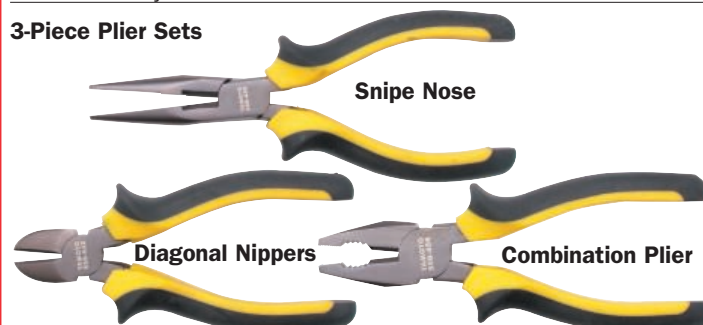

Number of Pieces	Contents	Order Code YMT-558	Price/1 TB
3	Snipe Nose 170mm Diagonal Nippers 150mm Combination Pliers 165mm	-9830K	944.00
3	Snipe Nose 200mm Diagonal Nippers 185mm Combination Pliers 210mm	-9850K	1070.00

PRODUCTS ARE ONLY AVAILABLE VIA YOUR DISTRIBUTOR

GROUP 558 PLIERS & GRIPS

KENNEDY PROFESSIONAL

Manufactured from specially selected steels. The dual material grip handle design allows the user to apply the greatest force with the minimum amount of effort. Manufactured with a polypropylene core for strength and durability with a soft thermoplastic outer for non-slip comfort grip.



Pro-Torq Combination Pliers with Side Cutters

Especially suitable for production line environments where repetitive work is undertaken. Double polished head and joint. Induction hardened cutting edges with serrated jaws for gripping nuts



Overall Length	Weight each	Order Code KEN-558	Price/1 TB
165mm (6 ¹ / ₂ "	210g	-6820K	582.00
180mm (7")	293g	-4800K	680.00
200mm (8")	370g	-6840K	637.00

Pro-Torq Insulated Combination Pliers

Especially suitable for production line environments where repetitive work is undertaken. Double polished head and joint for gripping nuts.

VDC/IEC 900
DIN EN 60900



Overall Length	Weight each	Order Code KEN-558	Price/1 TB
160mm (6 ³ / ₈ "	226g	-5140K	655.00
180mm (7")	290g	-5160K	690.00
205mm (8")	344g	-5180K	715.00

Pro-Torq Insulated Plier Set

3 Piece Set
Double polished head and joint with induction hardened cutting edges. VDC/IEC 900 DIN EN 60900.

3 Piece Set Contents:
nippers 145mm (5³/₄"
long nose 160mm (6³/₈"
combination 160mm (6³/₈"

**3
PIECES**



Number of Pieces	Order Code KEN-558	Price/1 TB
3	-6980K	2323.00

KENNEDY QUALITY INDUSTRIAL TOOLING

Universal Type Heavy Duty Combination Pliers



Universal type heavy duty combination pliers with single cutter. Chrome vanadium steel with heavy duty insulated handle with slip guard. Double polished head and joint. Serrated parallel jaws for gripping flat workpieces and a serrated curved jaw for gripping nuts, etc. Also with side cutter with induction hardened cutting edges.



Overall Length	Weight each	Order Code KEN-558	Price/1 TB
160mm (6 ³ / ₈ "	200g	-4520K	576.00
180mm (7")	275g	-4530K	583.00
205mm (8")	370g	-4540K	629.00

Universal Type Combination Pliers with Single Cutter

Chrome vanadium steel, bonded vinyl-coated handle. Double polished head and joint. Induction hardened cutting edges. Also with side cutter and serrated gripping and crimping jaws behind the head.



Overall Length	Weight each	Order Code KEN-558	Price/1 TB
115mm (4 ¹ / ₂ "	100g	-3500K	514.00
150mm (6")	217g	-3520K	551.00
180mm (7")	250g	-3530K	582.00
205mm (8")	367g	-3540K	615.00

Universal Type Combination Pliers with Joint Cutter

Chrome vanadium steel, bonded vinyl coated handle. Double polished head and joint. Induction hardened cutting edges. Also with side cutter, serrated gripping and crimping jaws behind the head and joint cutter for heavy duty wire cutting.

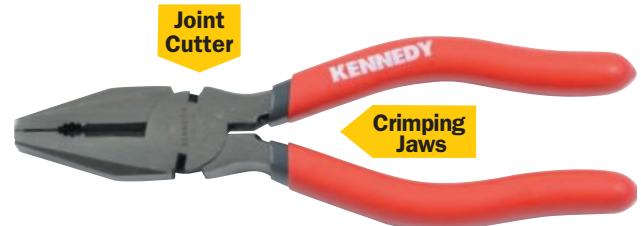

Overall Length	Weight each	Order Code KEN-558	Price/1 TB
180mm (7")	350g	-3460K	571.00

Soft Touch Engineer's Pliers - Slip Joint



Hardened steel body with replaceable soft nylon jaws and bonded vinyl-coated handle. For use on delicate or finished components which normal steel jaw pliers would mark or damage. Dual position joint allows use across a wide range of diameters. With serrated parallel jaws for gripping flat workpieces and curved jaw for gripping nuts, pipes etc.



Overall Length	Jaw Opening	Weight each	Order Code KEN-558	Price/1 TB
165mm	50mm	180g	-8960K	917.00
Pair of Jaws to suit		10g	-8970K	195.00

HAND TOOLS

SENATOR QUALITY TOOLING Multi-Function Plier Tools



A range of folding pliers with 'pen-knife' style blades. Featuring knives, can/bottle openers, metal/wood files (single and double cut), screwdrivers, chisels, saw blades, rules, wire benders, fish scalers, hook removers etc. Ideal for maintenance engineers, DIY enthusiasts, fishermen and hobbyists. Manufactured from the finest quality steel.

MTM610: 6 Blade - 10 Function

All stainless steel construction, spring-loaded pliers, easy to open blades. Folds down to a compact 20 x 70mm.

Plier overall dimensions: 105 x 320mm.

Functions:

35mm clipt point mini knife blade, 5 x 25mm flat screwdriver, bottle opener with 2mm flat driver, flat single/double cut file with hook remover, 35mm reamer, tin opener, serrated jaw pliers, wire cutting jaws, spring return opener, key ring.



**6 Blades
10 Functions**

Model Number	Number of Functions	Order Code SEN-558	Price/1 TB
MTM610	10	-5010K	398.00

MTS1016: 10 Blade - 16 Function

All stainless steel construction, easy to open blades. Folds down to a compact 30 x 115mm.

Plier overall dimensions: 55 x 180mm.

Functions:

55mm scalloped edge knife with 8mm chisel blade, 60mm wood cutting blade with hook remover, 65mm clipt point super sharp knife blade, 5 x 22mm flat screwdriver, 7mm flat screwdriver with bottle opener, 2 x 25mm flat screwdriver, 70mm single/double cut file, awl/punch tool, No.4 x 4mm crosspoint screwdriver, tin opener, long nosed pliers with serrated jaws, bypass action wire cutters.



**10 Blades
16 Functions**

Model Number	Number of Functions	Order Code SEN-558	Price/1 TB
MTS1016	16	-5040K	485.00

MTS1015: 10 Blade - 15 Function

All stainless steel construction, easy to open blades. Folds down to a compact 25 x 100mm.

Plier overall dimensions: 50 x 163mm.

Functions:

60mm super sharp knife blade, 60mm scalloped edge knife, 5 x 22mm screwdriver blade, 7 x 25mm screwdriver blade, 2 x 20mm flat screwdriver, awl/punch tool, 65mm single/double cut file, No.0 x 25mm crosspoint screwdriver, inch graduated rule with fish descaler and hook remover, tin opener, long nose pliers with flat and curved serrated jaws, bypass action wire cutters.



**10 Blades
15 Functions**

Model Number	Number of Functions	Order Code SEN-558	Price/1 TB
MTS1015	15	-5030K	551.00

YAMOTO INDUSTRIAL PLIERS Combination Pliers



Industrial quality chrome vanadium steel, chemically blacked. Particularly useful for engineers and electricians. Serrated jaws for gripping nuts, bolts, studs etc.



Overall Length	Weight each	Order Code YMT-558	Price/1 TB
160mm (6")	180g	-4560K	312.00
185mm (7")	310g	-4570K	352.00
210mm (8")	400g	-4580K	407.00

SENATOR QUALITY TOOLING Engineer's Pliers - Slip Joint



Chrome vanadium with a chrome finish and textured grip dipped handles. With serrated parallel jaws for gripping flat workpieces and curved jaw for gripping nuts, pipes etc. Dual position joint allows use across a wide range of diameters.

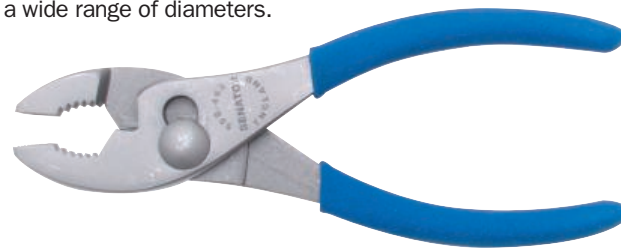

Overall Length	Weight each	Order Code SEN-558	Price/1 TB
150mm (6")	190g	-4630K	158.00
200mm (8")	250g	-4640K	209.00
255mm (10")	405g	-4650K	263.00

Heavy Duty Lineman's Pliers

Heavy duty standard manufactured from chrome vanadium steel with a satin finish. Serrated jaws for gripping nuts, bolts, studs etc. Side cutting for wire up to 1.6mm diameter. Also with serrated gripping and crimping jaws behind the head.



Overall Length	Weight each	Order Code SEN-558	Price/1 TB
160mm (6 ³ / ₈ ")	190g	-4560K	226.00
185mm (7 ¹ / ₂ ")	260g	-4570K	263.00
210mm (8 ³ / ₈ ")	330g	-4580K	289.00

Heavy Duty Plier Set

Heavy duty standard manufactured from chrome vanadium steel with a satin finish.

Overall length: 150mm (6"):

3 Piece Set Contents: long nose pliers with cutter, diagonal cutting nippers, linesman's pliers.



Number of Pieces	Order Code SEN-558	Price/1 TB
3	-9830K	876.00

HAND TOOLS

GROUP 558 PLIERS & GRIPS

KENNEDY PROFESSIONAL

Manufactured from specially selected steels. The dual material grip handle design allows the user to apply the greatest force with the minimum amount of effort. Manufactured with a polypropylene core for strength and durability with a soft thermoplastic outer for non-slip comfort grip. Especially suitable for production line environments where repetitive work is undertaken. Double polished head and joint. Induction hardened cutting edges with serrated jaws for gripping nuts.



Pro-Torq Bent Nose Pliers with Side Cutter



Overall Length	Weight each	Order Code KEN-558	Price/1 TB
160mm (6 ³ / ₈ "	165g	-4820K	723.00
200mm (8")	190g	-4840K	869.00

Pro-Torq Insulated Bent Nose Pliers

VDC/IEC 900
DIN EN 60900



Overall Length	Weight each	Order Code KEN-558	Price/1 TB
205mm (8")	212g	-5060K	697.00

Pro-Torq Flat Nose Pliers



Overall Length	Weight each	Order Code KEN-558	Price/1 TB
160mm (6 ³ / ₈ "	167g	-4920K	671.00

Professional Glow Plug Connector Pliers

Suitable for the removal of hard to reach glow plug connectors found on the latest generation of engines. Made from chrome vanadium steel. Composite handle provides added comfort and control.

Blade length: 125mm.

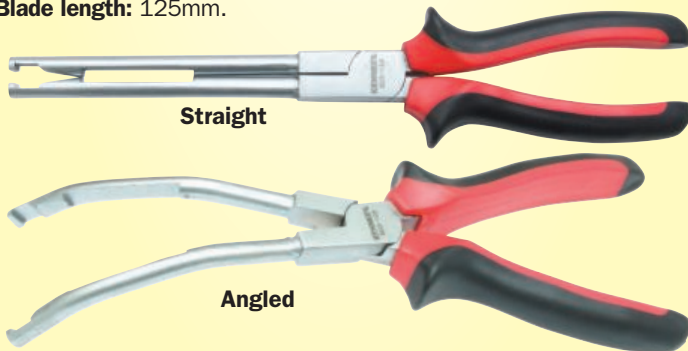

Jaw Type	Order Code KEN-503	Price/1 TB
Straight	-1240K	1327.00
Angled	-1260K	1433.00

KENNEDY QUALITY INDUSTRIAL TOOLING

Bent Nose Pliers with Side Cutter



Chrome vanadium steel, bonded vinyl coated handle. Double polished head and joint with induction hardened cutting edges. Serrated jaws with side cutter.



Overall Length	Weight each	Order Code KEN-558	Price/1 TB
160mm (6 ³ / ₈ "	166g	-3250K	567.00
200mm (8")	234g	-3260K	614.00

Flat Nose Pliers

Ideal for general gripping especially thin materials. Bonded vinyl coated handle. Double polished head and joint. Induction hardened cutting edges.



* Serrated jaws

Overall Length	Weight each	Order Code KEN-558	Price/1 TB
140mm (5 ¹ / ₂ "	108g	-3020K	546.00
*160mm (6 ³ / ₈ "	183g	-3050K	527.00

Pointed Nose Assembly Pliers

Bonded vinyl-coated handle. Double polished head and joint with induction hardened cutting edges.



Overall Length	Weight each	Order Code KEN-558	Price/1 TB
125mm (5")	91g	-3150K	609.00

Electrician's Flat Nose Pliers with Notched Wire Cutter

Bonded vinyl-coated handle. Double polished head and joint. Induction hardened cutting edges. Serrated jaws.



Overall Length	Weight each	Order Code KEN-558	Price/1 TB
160mm (6 ³ / ₈ "	166kg	-3140K	662.00

HAND TOOLS

KENNEDY *Snipe Nose Pliers with Cutter*

Chrome vanadium steel, with bonded vinyl coated handle. Double polished head and joint with induction hardened cutting edges. Also with side cutter and serrated gripping and crimping jaws behind the head.

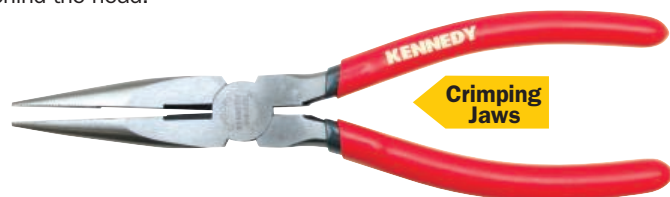

Crimping Jaws

Overall Length	Weight each	Order Code KEN-558	Price/1 TB
140mm (5½")	118g	-3200K	504.00
160mm (6¾")	147g	-3210K	527.00
200mm (8")	218g	-3230K	549.00

Long Jaw Round Nose Pliers

Bonded vinyl-coated handle. Double polished head and joint. Induction hardened cutting edges. The round nose jaws allow the forming of loops in wire or thin strips of material.



Overall Length	Weight each	Order Code KEN-558	Price/1 TB
160mm (6¾")	142g	-3120K	546.00

YAMOTO *Long Nose Pliers*

Industrial quality chrome vanadium steel, chemically blacked. Ideal for terminal loupe forming, wire manipulation and shape forming in confined spaces. Round jaw finish with smooth action single joints and hardened cutting edges. Laser etched markings. Bi-material grips.



Overall Length	Weight each	Order Code YMT-558	Price/1 TB
135mm (5¼")	110g	-4180K	228.00
170mm (6¾")	110g	-4200K	268.00
190mm (7½")	120g	-4210K	316.00
200mm (8")	180g	-4230K	329.00

SENATOR *Heavy Duty Snipe Nose Pliers with Cutter*

Heavy duty standard manufactured from chrome vanadium with satin finish. Built-in serrated section behind head for gripping. Hard wearing with PVC safety handles and side cutter.



Crimping Jaws

Overall Length	Weight each	Order Code SEN-558	Price/1 TB
125mm (5")	115g	-4200K	256.00
150mm (6")	160g	-4210K	282.00
200mm (8")	215g	-4230K	375.00

KENNEDY PROFESSIONAL

Manufactured from specially selected steels. The dual material grip handle design allows the user to apply the greatest force with the minimum amount of effort. Manufactured with a polypropylene core for strength and durability with a soft thermoplastic outer for non-slip comfort grip. Especially suitable for production line environments where repetitive work is undertaken. Double polished head and joint. Induction hardened cutting edges with serrated jaws for gripping nuts.



Pro-Torq Snipe Nose Pliers with Side Cutter

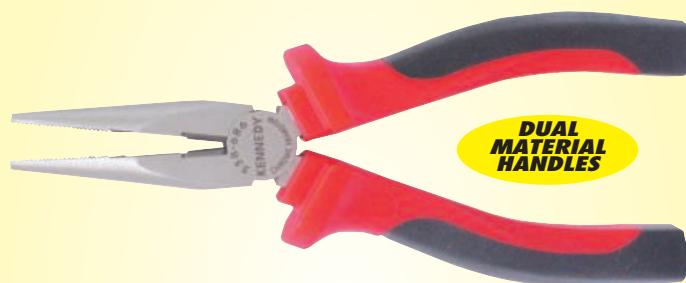

DUAL MATERIAL HANDLES

Overall Length	Weight each	Order Code KEN-558	Price/1 TB
165mm (6½")	140g	-6860K	564.00
215mm (8½")	210g	-6880K	614.00

Pro-Torq Insulated Snipe Nose Pliers

VDC/IEC 900
DIN EN 60900

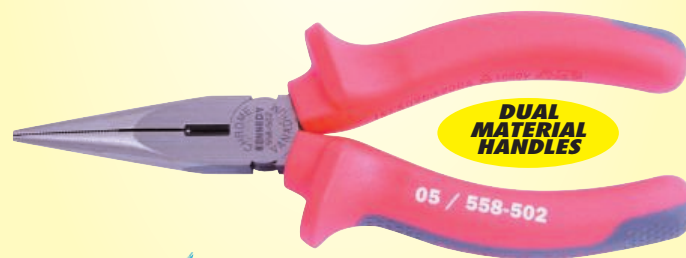

DUAL MATERIAL HANDLES



Overall Length	Weight each	Order Code KEN-558	Price/1 TB
160mm (6¾")	157g	-5020K	589.00
205mm (8")	221g	-5040K	636.00

KENNEDY *Heavy Duty Snipe Nose Pliers with Cutter*

Chrome vanadium steel, heavy duty handle with slip guard. Double polished head and joint with induction hardened cutting edges. Also with side cutter and serrated gripping and crimping jaws behind the head.



Crimping Jaws

Overall Length	Weight each	Order Code KEN-558	Price/1 TB
140mm (5½")	125g	-4200K	709.00
160mm (6¾")	150g	-4210K	555.00
200mm (8")	200g	-4230K	587.00

HAND TOOLS

GROUP 558 PLIERS & GRIPS

KENNEDY PROFESSIONAL

Pro-Torq End Cutting Nippers

Manufactured from specially selected steels. Dual material grip handle. Manufactured with a polypropylene core for strength and durability with a soft thermoplastic outer for non-slip comfort grip. Double polished head and joint. Induction hardened cutting edges.



Overall Length	Weight each	Order Code KEN-558	Price/1 TB
160mm (6 ³ / ₈ "")	261g	-4860K	729.00
200mm (8")	408g	-4880K	834.00

Manufactured from specially selected steels. The dual material grip handle design allows the user to apply the greatest force with the minimum amount of effort. Manufactured with a polypropylene core for strength and durability with a soft thermoplastic outer for non-slip comfort grip. Especially suitable for production line environments where repetitive work is undertaken. Double polished head and joint. Induction hardened cutting edges.

Pro-Torq Diagonal Cutting Nippers



Overall Length	Weight each	Order Code KEN-558	Price/1 TB
125mm (5")	170g	-6900K	564.00
165mm (6 ¹ / ₂ "")	210g	-6920K	582.00

Pro-Torq Insulated Diagonal Cutting Nippers

VDC/IEC 900
DIN EN 60900



Overall Length	Weight each	Order Code KEN-558	Price/1 TB
145mm (5 ³ / ₄ "")	215g	-5080K	646.00
160mm (6 ³ / ₈ "")	205g	-5100K	786.00
205mm (8")	262g	-5120K	831.00

KENNEDY End Cutting Nippers

Bonded vinyl-coated handle, double polished head and joint with induction hardened cutting edges. The robust construction makes these ideal for twisting and cutting wire in the construction industry.



Overall Length	Weight each	Order Code KEN-558	Price/1 TB
160mm (6 ³ / ₈ "")	1.30kg	-3620K	1583.00

High Tensile Diagonal Cutting Pliers

Chrome vanadium steel, with bonded vinyl coated handle. Double polished head and joint. Induction hardened cutting edges.



Overall Length	Weight each	Order Code KEN-558	Price/1 TB
160mm (6 ³ / ₈ "")	216g	-3410K	710.00
180mm (7")	283g	-3430K	812.00

Heavy Duty Diagonal Cutting Nippers

Heavy duty handle with slip guard. Double polished head and joint. Induction hardened cutting edges.



Overall Length	Weight Per 6	Order Code KEN-558	Price/1 TB
140mm (5 ¹ / ₂ "")	0.83g	-4300K	562.00
160mm (6 ³ / ₈ "")	1.20g	-4320K	576.00
180mm (7")	1.30g	-4330K	769.00

Standard Diagonal Cutting Nippers

Bonded vinyl coated handle. Double polished head and joint. Induction hardened cutting edges. Designed to give added strength at the point yet still fit into confined spaces. The cutting edge is offset at a slight angle to the handles to allow close cuts to a flat surface.



Overall Length	Weight Per 6	Order Code KEN-558	Price/1 TB
130mm (5 ¹ / ₄ "")	0.75kg	-3300K	514.00
160mm (6 ³ / ₈ "")	1.10kg	-3320K	551.00
180mm (7")	1.30kg	-3330K	750.00

Wire Rope Cutters



Contoured steel handles with vinyl grip for improved comfort and control. Heavy duty blades manufactured from tempered and hardened high carbon steel with polished finish. Spring-loaded cutting action for easy one-handed operation with safety lock.

Wire rope capacity: 4.8mm,
Spring wire: 1.5mm.



Length (mm)	Weight each	Order Code KEN-558	Price/1 TB
150mm	350g	-5700K	792.00

SENATOR QUALITY TOOLING



High Tensile Diagonal Cutting Nippers

Chrome vanadium with textured dipped handles for use on hard wire.



Overall Length	Weight each	Order Code SEN-558	Price/1 TB
175mm (7")	180g	-4430K	423.00

Heavy Duty Diagonal Cutting Nippers

Chrome vanadium steel with a satin finish. Also have a serrated section behind the head for gripping. Hard wearing heavy duty PVC safety handles.

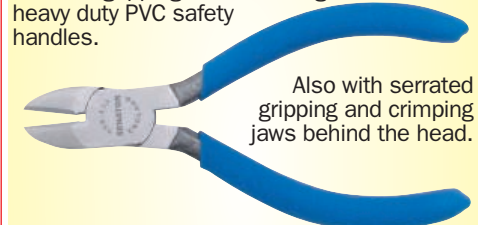

Overall Length	Weight each	Order Code SEN-558	Price/1 TB
125mm (5")	170g	-4300K	267.00
150mm (6")	205g	-4320K	292.00
200mm (8")	270g	-4340K	389.00

YAMOTO Diagonal Cutting Nippers

Industrial quality chrome vanadium steel, chemically blacked. Designed to give added strength at the point and allow hard wire to be cut without damaging the edge. Bi-material grips.



Overall Length	Weight each	Order Code YMT-558	Price/1 TB
130mm (5 ¹ / ₄ "")	110g	-4300K	232.00
160mm (6 ¹ / ₄ "")	170g	-4320K	284.00
185mm (7 ¹ / ₄ "")	230g	-4340K	335.00

HAND TOOLS

KENNEDY *Heavy Duty Cable Cutters*
QUALITY INDUSTRIAL TOOLING

For use when cutting aluminium and copper cable, using a slicing action. Manufactured from forged steel with PVC dipped handles.

Capacity: 60mm².



Overall Length	Weight each	Order Code KEN-558	Price/1 TB
255mm	516g	-8220K	1583.00

Electronics Shear

Ground carbon steel blades. Cushion spring-loaded plastic grips. Steel plate spring. Non-bevelled cutting edges for flush cutting. Burnished head. Cuts copper wire up to 14AWG.



Grip Type	Overall Length	Weight each	Order Code KEN-558	Price/1 TB
Standard	130mm	75g	-4060K	633.00

Light Duty Cable Cutters

For cutting copper cable, plastic pipe, wooden dowels, rope cord and similar materials up to 10mm diameter. Precision ground and hardened stainless steel blades 50~54HRC. Lightweight polypropylene handles with spring loaded action.



Easy reach thumb catch convenient for right and left hand users.

Overall length: 165mm (6½").
Cutting capacity: 10mm (¾").

Cutting Capacity	Overall Length	Weight each	Order Code KEN-558	Price/1 TB
10mm	165mm	130g	-5640K	471.00

Lever Type Cable Cutter

These cable cutters have heat-treated cutting edges and are designed to cut copper/aluminium cables with minimal distortion. The soft grip handles are designed for user comfort whilst exerting force.

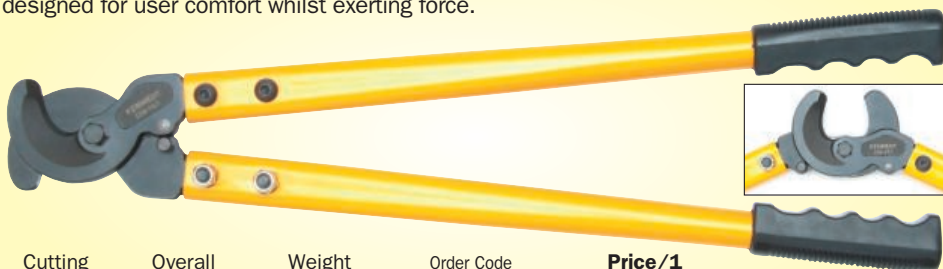

Cutting Capacity	Overall Length	Weight each	Order Code KEN-558	Price/1 TB
18mm	380mm	3.4kg	-9400K	2717.00
25mm	550mm	3.4kg	-9410K	5157.00
40mm	820mm	3.4kg	-9420K	6541.00

Cable Cutters

Drop-forged from high carbon micro alloyed steel induction hardened blades. Tough double tempered handles. For cutting copper cable up to 10mm diameter.



Overall Length	Weight each	Order Code KEN-558	Price/1 TB
200mm		-5680K	1288.00

Ratcheting Cable Cutter

Manufactured from high tensile steel. For cutting copper, aluminium and multiple strand cable. Fully hardened cutting edges produce burr-free cuts. Compound lever action for maximum efficiency and moulded cushion grips for user comfort.



Cutting Capacity	Weight each	Order Code KEN-558	Price/1 TB
32mm	675g	-8200K	6923.00
Spare blades	75g	KEN-567-5500K	2136.00

Ratchet Type Cable Cutter

These cable cutters have heat treated cutting edges and are designed to cut copper/aluminium cables with minimal distortion.



The soft grip handles are designed for user comfort whilst exerting force.

Cutting Capacity	Overall Length	Weight each	Order Code KEN-558	Price/1 TB
32mm	335mm	995g	-9500K	9785.00
38mm	335mm	995g	-9510K	12875.00

Carpenter's Pincers

Ideal for the easy removal of tacks and nails. Bonded vinyl-coated handle, double polished head and joint with induction hardened cutting edges.

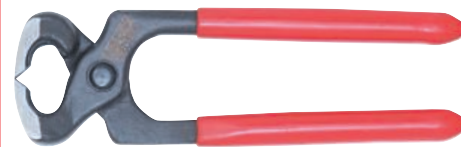

Overall Length	Weight Per 6	Order Code KEN-558	Price/1 TB
150mm (6")	2.20kg	-3730K	667.00
180mm (7")	2.00kg	-3740K	723.00
200mm (8")	2.40kg	-3760K	1078.00

O-Clip Pincers

O-clip pincers are designed for rapidly closing O-clips ensuring a positive tamperproof seal. Manufactured from chrome vanadium steel with induction hardened, ground and polished jaws.



NEW

Bonded vinyl-coated handle. Overall length: 200mm.

Overall Length	Order Code KEN-558	Price/1 TB
200mm (8")	-1000K	773.00

Fencing Tool

Chrome vanadium steel, with heavy duty handle with slip guard. Double polished head and joint. Induction hardened cutting edges. Also with serrated gripping and crimping jaws behind the head.



Overall Length	Weight each	Order Code KEN-558	Price/1 TB
270mm (10½")	716g	-3720K	1029.00

SENATOR *Miniature Plier Set*
QUALITY TOOLING

5 Piece Set

Used for precision work on a number of applications. Spring tensioned pliers suited for repetitive use. Fitted with slip-resistant PVC cushion grip handles and heat-treated stainless steel blades.

Hardness:

Pliers 42 - 45HRC, Nippers 45 - 48HRC.

Set contents: diagonal nippers 90mm; 45° bent nose pliers, pointed nose pliers, round nose pliers, and flat nose pliers all 100mm.

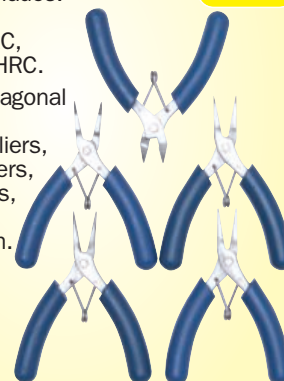

Number of Pieces	Weight each	Order Code SEN-558	Price/1 TB
5	265g	-8010K	1060.00

HAND TOOLS

GROUP 558 PLIERS & GRIPS

KENNEDY PROFESSIONAL Pro-Torg Miniature ESD Pliers & Cutters

Dissipative handles safely discharge any electrostatic energy, reducing possibility of damage to sensitive items. The dual material grip handle design allows the user to apply the greatest force with the minimum amount of effort. These are manufactured with a polypropylene core for strength and durability with a soft thermoplastic outer for non-slip comfort grip.

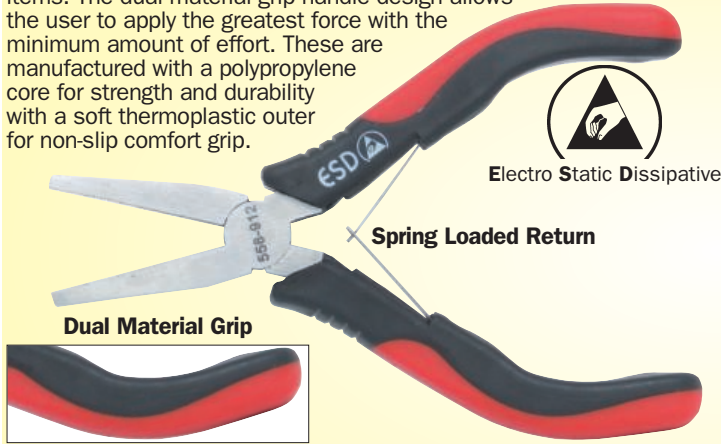

Type	Overall Length	Order Code KEN-558	Price/1 TB
Flat Nose	130mm	-9120K	550.00
Bent Nose	140mm	-9160K	550.00
Long Nose	130mm	-9130K	550.00
Needle Nose	140mm	-9150K	550.00
Micro Diagonal Cutters	110mm	-9060K	550.00
Diagonal Cutters	115mm	-9080K	550.00

	Side View	End View	Head
Flat Nose			
Bent Nose			
Long Nose			
Needle Nose			
Micro Diagonal Cutters			
Diagonal Cutters			

KENNEDY QUALITY INDUSTRIAL TOOLING Electronics Pliers & Cutters

Made from high quality chrome vanadium with ground finish jaws and bonded vinyl grip for user comfort and control. Used for delicate, fine and accurate work in a continuous production environment. Spring-loaded return for quick repetitive opening and operator comfort.

Overall length: 120mm.

Box Joint

Distributes tension equally to both sides of each jaw, avoiding 'twisting' of pliers.

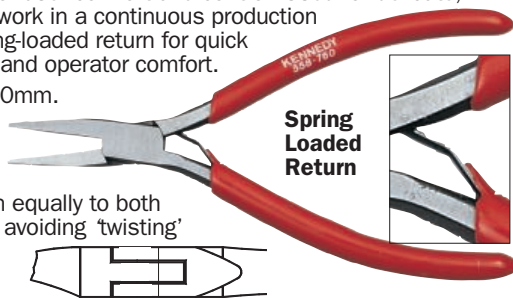

	Side View	End View	Head
Flat Nose			
Round Nose			
Pointed Bent Nose			
Pointed Nose			
Diagonal Cutters			
End Cutters			
Oblique Cutters			

Type	Overall Length	Order Code KEN-558	Price/1 TB
Flat Nose	120mm	-7600K	1476.00
Round Nose	120mm	-7610K	1476.00
Pointed Bent Nose	120mm	-7620K	1709.00
Pointed Nose	120mm	-7630K	1709.00
Pointed Nose - Single Joint	120mm	-7330K	1709.00
Diagonal Cutters	120mm	-7640K	1834.00
End Cutters	120mm	-7650K	2085.00
Oblique Cutters	120mm	-7660K	2015.00

Stainless Steel Pliers & Cutters

Manufactured from heat-treated stainless steel.

Hardness: pliers 42 - 45HRC; nippers 45 - 48HRC.

Used for delicate, fine and accurate work in a continuous production environment. Spring-loaded return for quick repetitive opening and operator comfort.

Cushioned foam safe-grip handles for user comfort and control.

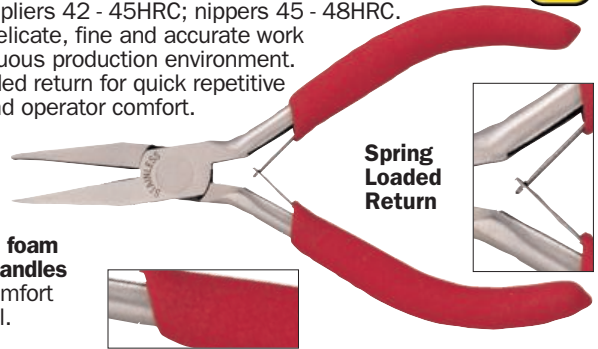

	Side View	End View	Head
Flat Nose			
Long Nose			
Bent Nose			
Needle Nose			
Diagonal Cutters			
End Cutters			
Long Needle Nose			

Type	Overall Length	Order Code KEN-558	Price/1 TB
Flat Nose	120mm	-2560K	399.00
Long Nose	120mm	-2530K	399.00
Bent Nose	120mm	-2520K	399.00
Needle Nose	120mm	-2510K	399.00
Diagonal Cutters	120mm	-2540K	399.00
End Cutters	120mm	-2550K	399.00
Long Needle Nose	180mm	-2610K	399.00

HAND TOOLS

KENNEDY *Miniature Pliers*
QUALITY INDUSTRIAL TOOLING

Made from high quality chrome nickel steel with induction ground cutting edges. Double dipped PVC grips for user comfort and control. Used for delicate, fine and accurate work in a continuous production environment. Spring loaded return for quick repetitive opening and operator comfort.



KENNEDY PROFESSIONAL *Pro-Torq Miniature Pliers*



The dual material grip handle design allows the user to apply the greatest force with the minimum amount of effort. These are manufactured with a polypropylene core for strength and durability with a soft thermoplastic outer for non-slip comfort grip. Made from high quality chrome nickel steel with induction ground cutting edges. Used for delicate, fine and accurate work in a continuous production environment.

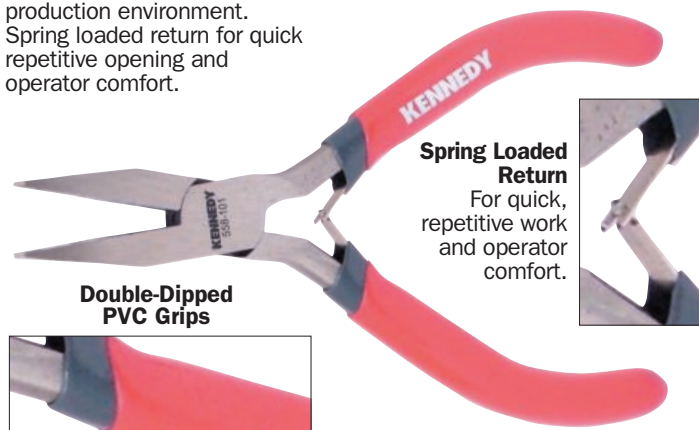

Double-Dipped PVC Grips

Spring Loaded Return
 For quick, repetitive work and operator comfort.



Dual Material Grip

Spring-Loaded Return
 For quick, repetitive work and operator comfort.

	Side View	End View	Head
Flat Nose			
Bent Nose			
Long Nose			
Needle Nose			
Diagonal Cutters			
End Cutters			

Type	Overall Length	Order Code KEN-558	Price/1 TB
Flat Nose	130mm	-7440K	625.00
Bent Nose	120mm	-7430K	550.00
Long Nose	130mm	-7450K	625.00
Needle Nose	150mm	-7460K	650.00
Diagonal Cutters	110mm	-7410K	499.00
End Cutters	110mm	-7420K	499.00

	Side View	End View	Head
Flat Nose			
Bent Nose			
Long Nose			
Needle Nose			
Diagonal Cutters			
End Cutters			

Type	Overall Length	Order Code KEN-558	Price/1 TB
Flat Nose	130mm	-1210K	582.00
Bent Nose	120mm	-1230K	593.00
Long Nose	130mm	-1240K	567.00
Needle Nose	150mm	-1220K	593.00
Diagonal Cutters	110mm	-1250K	582.00
End Cutters	110mm	-1260K	582.00

HAND TOOLS

Set
 Supplied in a cushioned zip around case with elasticated tool loops to keep the pliers and cutters secure.

- Contents:**
 1x flat nose - 130mm,
 1x bent nose - 120mm,
 1x long nose - 130mm,
 1x needle nose - 150mm,
 1x diagonal cutters - 110mm,
 1x end cutters - 110mm.



**6
PIECES**

Number of Pieces	Order Code KEN-558	Price/1 TB
6	-7470K	2999.00

Set
 Supplied in a cushioned zip around case with elasticated tool loops to keep the pliers and cutters secure.

- Contents:**
 1x flat nose - 130mm,
 1x bent nose - 120mm,
 1x long nose - 130mm,
 1x needle nose - 150mm,
 1x diagonal cutters - 110mm,
 1x end cutters - 110mm.



**6
PIECES**

Number of Pieces	Order Code KEN-558	Price/1 TB
6	-1300K	3760.00

GROUP 558 PLIERS & GRIPS

KENNEDY PROFESSIONAL Pro-Torg Sprung Circlip Pliers

Manufactured from specially selected steels. The dual material grip handle design allows the user to apply the greatest force with the minimum amount of effort. These are manufactured with a polypropylene core for strength and durability with a soft thermoplastic outer for non-slip comfort grip. Double polished head and joint. Induction hardened cutting edges. Especially suitable for production line environments where repetitive work is undertaken.

Sprung Straight Jaw Circlip Pliers - Internal

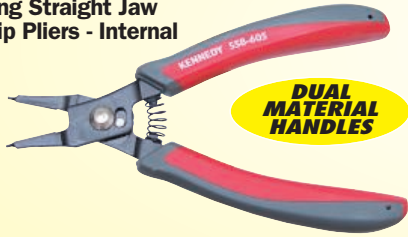

DUAL MATERIAL HANDLES

Circlip Capacity	Overall Length	Order Code KEN-558	Price/1 TB
10 - 25mm	150	-6050K	503.00
12 - 65mm	170	-6070K	558.00

Sprung Straight Jaw Circlip Pliers - External



DUAL MATERIAL HANDLES

Circlip Capacity	Overall Length	Order Code KEN-558	Price/1 TB
10 - 25mm	150	-6060K	503.00
19 - 40mm	170	-6080K	558.00

Sprung Internal & External Straight Jaw 4 Piece Circlip Plier Set

Supplied in a plastic moulded carry case.



DUAL MATERIAL HANDLES

Contents 1 of each:

External straight jaw, 10 - 25mm and 19 - 40mm.
Internal straight jaw, 10 - 25mm and 12 - 65mm.



4 PIECES

Number of Pieces	Weight each	Order Code KEN-558	Price/1 TB
4	490g	-6090K	2292.00

KENNEDY QUALITY INDUSTRIAL TOOLING

European Pattern Circlip Pliers

Industrial quality chrome vanadium hardened and tempered. PVC cushion grip handles. Coil sprung to aid operation.

External - Straight Jaw



Circlip Capacity	Length (mm)	Order Code KEN-558	Price/1 TB
10 - 25mm	125	-6520K	393.00
19 - 40mm	175	-6570K	442.00
32 - 60mm	250	-6620K	866.00

External - 90° Angled Jaw



Circlip Capacity	Length (mm)	Order Code KEN-558	Price/1 TB
10 - 25mm	125	-6530K	393.00
19 - 40mm	175	-6580K	442.00
32 - 80mm	250	-6630K	866.00

Internal - Straight Jaw



Circlip Capacity	Length (mm)	Order Code KEN-558	Price/1 TB
10 - 25mm	125	-6500K	393.00
19 - 65mm	175	-6550K	442.00
32 - 60mm	250	-6600K	866.00

Internal - 90° Angled Jaw



Circlip Capacity	Length (mm)	Order Code KEN-558	Price/1 TB
10 - 25mm	125	-6510K	393.00
19 - 65mm	175	-6560K	442.00
32 - 80mm	250	-6610K	866.00

Circlip Pliers

Long Handled

Industrial quality chrome vanadium hardened and tempered. PVC cushion grip handles. Coil sprung to aid operation.

Overall length: 300mm (12").



External

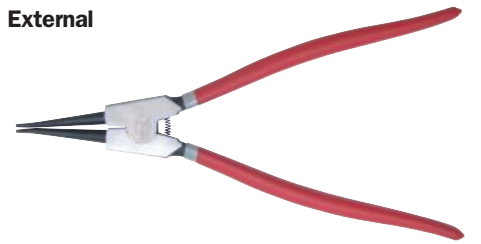

Circlip Capacity	Jaw	Order Code KEN-558	Price/1 TB
85 - 165mm	Straight	-6670K	1227.00
	90° angled	-6680K	1227.00

Internal



Circlip Capacity	Jaw	Order Code KEN-558	Price/1 TB
85 - 165mm	Straight	-6650K	1187.00
	90° angled	-6660K	1227.00

Mini Circlip Pliers

4 Piece Set

Set of four pliers for internal and external circlips (range 10-30mm). The pliers feature non-slip PVC grips and spring-loaded jaws.

The set comprises Straight and Bent Nose, Internal and External Pliers.



4 PIECES

NEW

Number of Pieces	Order Code KEN-558	Price/1 TB
4	-6160K	979.00

Heavy Duty Snap Ring Pliers

Ratcheting

Heat-treated steel circlip pliers for large equipment repair. Replaceable tips and spring ratchet locking mechanism to securely hold against snap ring tension.

Black powder coated. Galvanised tips and lock lever. Insulated lever handle.
Overall length: 510mm (20").
Circlip capacity: 165 - 300mm



Type	Jaw	Order Code KEN-558	Price/1 TB
Internal	Straight	-6700K	4096.00
	90° angled	-6710K	3865.00
External	Straight	-6720K	3865.00
	90° angled	-6730K	3865.00

Spare Jaws	Order Code KEN-567	Price/1 TB
Straight	-3820K	366.00
Angled	-3840K	366.00

HAND TOOLS



Reversible Circlip Pliers

These straight and bent nose pliers are reversible for both internal and external circlip insertion and removal, made from high grade carbon steel with comfortable insulated handles.

Straight Jaw



Circlip Capacity	Length (mm)	Order Code KEN-558	Price/1 TB
10 - 18mm	150	-5870K	517.00
12 - 25mm	150	-5890K	513.00
18 - 48mm	210	-5910K	568.00

45° Angled Jaw



Circlip Capacity	Length (mm)	Order Code KEN-558	Price/1 TB
10 - 18mm	150	-5880K	517.00
12 - 25mm	150	-5900K	513.00
18 - 48mm	210	-5920K	568.00

Straight & Bent Nose 6 Piece Reversible Circlip Plier Set

Contents: one of each type and size as listed above. Supplied in moulded carry case.



**6
PIECES**

Number of Pieces	Weight each	Order Code KEN-558	Price/1 TB
6	1.30g	-5930K	3547.00

Interchangeable Head Circlip Plier Set

Four piece circlip plier set - six tools in one. Internal and external 0°, 45° and 90°.

Overall length: 165mm (6½").

Capacity:

10 - 50mm (¾" - 2").

Straight (x2)



**5
PIECES**

Number of Pieces	Weight each	Order Code KEN-558	Price/1 TB
5	210g	-6750K	659.00

Heavy Duty Wire Strippers

Multi-purpose tool with alloy steel jaws suitable for stripping, cutting and crimping all types of wire. Automatic wire stripper.



Crimps: non-insulated terminals 1.5, 2.5 and 4 - 6mm 12 - 10, 22 - 18 and 16 - 14 AWG).

Crimps: insulated terminals 1.5, 2.5 and 6mm (10 - 22 AWG).

Capacity: 0.13 - 6.0mm².

Overall Length	Order Code KEN-558	Price/1 TB
200mm	-3600K	1207.00



Manufactured from specially selected steels. The dual material grip handle design allows the user to apply the greatest force with the minimum amount of effort. Manufactured with a polypropylene core for strength and durability with a soft thermoplastic outer for non-slip comfort grip.

Pro-Torq Wire Strippers

Double polished head and joint. Serrated parallel jaws and a serrated curved jaw. Also with side cutter with induction hardened cutting edges. Especially suitable for production line environments where repetitive work is undertaken.



DUAL MATERIAL HANDLES

Overall Length	Weight each	Order Code KEN-558	Price/1 TB
170mm (7")	223g	-4900K	775.00

Pro-Torq Insulated End Wire Strippers

Especially suitable for production line environments where repetitive work is undertaken. Double polished head and joint with induction hardened cutting edges.



**VDC/IEC 900
DIN EN 60900**

Overall Length	Weight each	Order Code KEN-558	Price/1 TB
160mm (6¾")	199g	-5200K	583.00

Standard Duty Wire Strippers

Bonded vinyl coated handle, double polished head and joint with induction hardened cutting edges. Brass adjusting screw. Jaws can be reset for perfect stripping every time.



Overall Length	Order Code KEN-558	Price/1 TB
155mm (6")	-3590K	595.00

Wire Twisting Pliers

Manufactured from chrome vanadium steel with ground and polished head. Cross knurled jaws with wire cutter. Used for safety-wiring critical fasteners and electrical connectors.



Size	Order Code KEN-558	Price/1 TB
8"	-3900K	1419.00
10"	-3920K	1495.00

Revolving Punch Pliers

Heavy Duty

Suitable for producing 2, 2.5, 3, 3.5, 4 and 4.5mm holes in a wide range of materials including card, PVC, etc. Hardened steel body with durable epoxy coating. The six revolving punches cutting edges are induction hardened. Compound lever action, requires 70% less force. Moulded contour grips with slip guards.



Overall Length	Order Code KEN-558	Price/1 TB
270mm (10½")	-3800K	1709.00

Revolving Punch Pliers

Standard Duty

For producing 2, 2.5, 3, 3.5, 4 and 4.5mm holes in a wide range of materials including card, PVC etc. Hardened steel body with durable epoxy coating. Six revolving punches cutting edges are induction hardened. Moulded contour grips.



Overall Length	Order Code KEN-558	Price/1 TB
250mm (10")	-3780K	954.00

HAND TOOLS

GROUP 558 PLIERS & GRIPS

KENNEDY PROFESSIONAL *Straight Jaw Bi-Material Handle Grip Wrenches*

Rollled chrome vanadium steel bodies, drop-forged hardened steel jaws with corrosion-resistant bright nickel coating. The dual material handle design allows the user to apply the greatest force with the minimum amount of effort. The jaw opening and clamping pressure can be adjusted with the knurled head screw, fitted with wire spring to ensure efficient opening of the jaws. The locking mechanism holds the wrench in place once adjusted, leaving both hands free.



Size	Type	Order Code KEN-558	Price/1 TB
7"	Straight Jaw	-7030K	910.00
10"	Straight Jaw	-7040K	1049.00

KENNEDY *Grip Wrenches*

Rollled chrome vanadium steel bodies, drop forged hardened steel jaws with corrosion-resistant bright nickel coating. The jaw opening and clamping pressure can be adjusted with the knurled head screw, fitted with wire spring to ensure efficient opening of the jaws. The locking mechanism holds the wrench in place once adjusted, leaving both hands free.

Straight Jaw
For general-purpose gripping.



Type/Duty	Overall Length	Max Clamp Pressure	Weight Per 10	Order Code KEN-558	Price/1 TB
Standard	125mm (5")	660lb ² in	1.90kg	-7050K	417.00
	180mm (7")	880lb ² in	2.10kg	-7070K	450.00
	255mm (10")	1320lb ² in	5.50kg	-7100K	477.00
Heavy	255mm (10")	2500lb ² in	6.00kg	-7130K	789.00

Set: Details as above.

Number of Pieces	Contents	Order Code KEN-558	Price/1 TB
2	1 each, 125 & 255mm	-7280K	1120.00

Long Nose

Specially designed with long slim jaws to enable access to restricted areas. With quick release.



Overall Length	Weight Per 6	Order Code KEN-558	Price/1 TB
150mm (6")	2.00kg	-8060K	382.00
230mm (9")	3.60kg	-8070K	495.00

KENNEDY *Grip Wrenches*

Rollled chrome vanadium steel bodies, drop forged hardened steel jaws with corrosion-resistant bright nickel coating. The jaw opening and clamping pressure can be adjusted with the knurled head screw, fitted with wire spring to ensure efficient opening of the jaws. The locking mechanism holds the wrench in place once adjusted, leaving both hands free.

Curved Jaw
Specially designed to grip circular objects. Ideal for plumbing and general pipe work.



Type/Duty	Overall Length	Max Clamp Pressure	Weight Per 10	Order Code KEN-558	Price/1 TB
Standard	125mm (5")	660lb ² in	1.90kg	-7150K	417.00
	180mm (7")	880lb ² in	2.10kg	-7170K	450.00
	255mm (10")	1320lb ² in	5.50kg	-7200K	477.00
Heavy	255mm (10")	2500lb ² in	6.00kg	-7230K	888.00

Set: Details as above.



Number of Pieces	Contents	Order Code KEN-558	Price/1 TB
2	1 each, 125 & 255mm	-7290K	1231.00

SENATOR *Curved Jaw Grip Wrenches*

High strength grip wrench bodies are manufactured from rolled chrome vanadium steel with serrated drop forged hardened steel jaws for a positive high strength grip every time. Each wrench is fitted with a wire spring to ensure efficient jaw opening.



Overall Length	Weight each	Order Code SEN-558	Price/1 TB
180mm (7")	310g	-7170K	280.00
255mm (10")	550g	-7200K	331.00

Straight Jaw Grip Wrenches

High strength.



Overall Length	Weight each	Order Code SEN-558	Price/1 TB
180mm (7")	350g	-7070K	284.00
255mm (10")	550g	-7100K	326.00

HAND TOOLS

KENNEDY *Hose Clamp*
QUALITY INDUSTRIAL TOOLING

Long rounded jaws with smooth section. For pinching off hoses without serration and gripping small sections of pipes. Invaluable aid for brake repairs on cars.



Diameter Capacity	Overall Length	Weight each	Order Code KEN-558	Price/1 TB
30mm	235mm	380g	-8180K	1338.00

Self-Levelling Grip Wrenches

The two knurled swivel pads ensure fully flat contact with the workpiece at the clamping point. Suitable for clamping tapered surfaces without slippage. Narrow jaw profile allows use in areas of confined access and where C-clamps cannot reach.



Capacity (mm)	Overall Length	Weight each	Order Code KEN-558	Price/1 TB
0 - 45	235mm	640g	-8460K	1961.00
0 - 100	300mm	790g	-8480K	2085.00

Grip Holder

Can be used as a normal C-type clamp or converts most 10"/12" grip wrenches into a versatile portable vice. Steel frame with butterfly adjustment screw and swivel clamping pad.

Capacity: 0 - 63mm.
Overall length: 110mm.
Grip wrench not included.



Capacity (mm)	Weight each	Order Code KEN-558	Price/1 TB
0 - 63	200g	-8020K	617.00

SENATOR *Long Jaw Grip Wrenches*
QUALITY TOOLING

High strength grip wrench bodies are manufactured from rolled chrome vanadium steel with serrated drop forged hardened steel jaws for a positive high strength grip every time. Each wrench is fitted with a wire spring to ensure efficient jaw opening.



Overall Length	Weight each	Order Code SEN-558	Price/1 TB
165mm (6½")	433g	-7260K	247.00
230mm (9")	600g	-7290K	326.00

Ideal Grip Wrench

Heavy duty chrome vanadium. With quick release. Two staged curved jaw design ideal for gripping small and large diameters. Particularly suited to gripping rounded off nuts and circular shaped objects.



Overall Length	Weight each	Order Code KEN-558	Price/1 TB
255mm (10")	600g	-7270K	1049.00

Parallel Plus Grip Wrench

Heavy duty chrome vanadium. With quick release. Self-adjusting lower jaw swivels into place. Grips squares, hexagons.



Overall Length	Weight each	Order Code KEN-558	Price/1 TB
255mm (10")	340g	-7250K	1342.00

Multi-Purpose Grip Wrench

The jaw configuration allows straight, curved and convex shapes to be gripped.



Capacity (mm)	Overall Length	Weight each	Order Code KEN-558	Price/1 TB
0 - 63	235mm	630g	-8040K	1325.00

Flat & Convex Grip Wrench

The convex jaw shape allows clearance around small obstacles and the broad jaw profile ensures that flat workpieces are clamped securely.



Capacity (mm)	Overall Length	Weight each	Order Code KEN-558	Price/1 TB
0 - 100	300mm	810g	-8420K	2306.00

HAND TOOLS

GROUP 558 PLIERS & GRIPS

KENNEDY *Sheet Metal Clamp*
QUALITY INDUSTRIAL TOOLING

The wide jaws distribute the clamping force evenly to prevent damaging the workpiece being handled.



Quick Release Lever

Overall Length	Weight each	Order Code	Price/1 TB
180mm (7")	470g	KEN-558	1602.00

Welder's Clamp

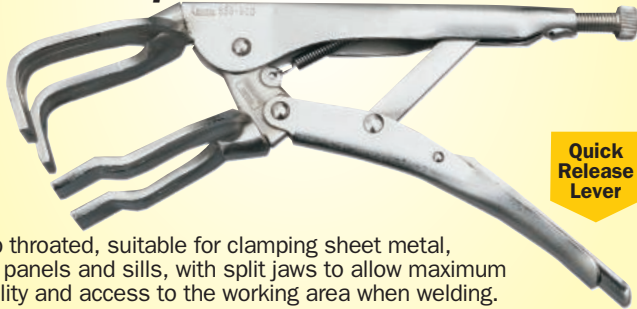

Quick Release Lever

Deep throated, suitable for clamping sheet metal, body panels and sills, with split jaws to allow maximum visibility and access to the working area when welding.

Overall Length	Weight each	Order Code	Price/1 TB
280mm (11")	790g	KEN-558	1545.00

Locking C-Clamps



Quick Release Lever

Wide and deep jaw profile, clears obstacles to firmly clamp sections that a normal grip wrench cannot.

Capacity (mm)	Overall Length	Weight each	Order Code	Price/1 TB
0 - 60	165mm (6½")	240g	-9270K	1236.00
0 - 100	300mm (12")	890g	-9280K	1442.00
0 - 260	460mm (18")	1300g	-9290K	2009.00
0 - 400	600mm (24")	145Kg	-9300K	2163.00

Locking C-Clamps - Swivel Pads



Quick Release Lever

Wide and deep jaw profile, clears obstacles to firmly clamp sections that a normal grip wrench cannot. With swivel contact pads to allow tapered surfaces to be clamped.

Capacity (mm)	Overall Length	Weight each	Order Code	Price/1 TB
0 - 50	165mm (6½")	0.30kg	-9330K	1339.00
0 - 80	320mm (13")	1.00kg	-9340K	1545.00
0 - 125	360mm (14½")	1.20kg	-8670K	3222.00
0 - 240	470mm (19")	1.45kg	-9350K	2009.00
0 - 400	630mm (25")	1.75kg	-9360K	2163.00

Axial Grip Wrenches



For auto body repair and steel fabrication. Chrome steel body with narrow profile jaws for confined areas. Straight line jaw motion allows clamping through holes. Push button release for one-handed clamp releasing. No provisional (or track) welding required to hold auto body parts for assembly.

Flanged Lap Joint Clamp

Clamps two flanged adjacent joints.

Jaw width: 18mm.
Throat depth: 7mm.



Capacity (mm)	Length (mm)	Weight each	Order Code	Price/1 TB
0 - 15	210mm (8½")	470g	-9240K	1391.00

Flanged, Lap & Adjacent Joint Clamp

Clamps two flanged and adjacent joints.

Jaw width: 45mm.
Throat depth: 25mm.



Capacity (mm)	Overall Length	Weight each	Order Code	Price/1 TB
0 - 10	210mm (8½")	550g	-9210K	1494.00

Lap & Spot Weld Joint Clamp

The 'W' shaped jaw allows four consecutive spot welds without moving the tool.

Jaw width: 57mm.
Throat depth: 36mm.



Capacity (mm)	Overall Length	Weight each	Order Code	Price/1 TB
0 - 12	195mm (7¾")	542g	-9220K	1597.00

Lap Joint Clamp

Clamps two lap joints.

Jaw width: 18mm.



Capacity (mm)	Overall Length	Weight each	Order Code	Price/1 TB
0 - 18	195mm (7¾")	410g	-9200K	1288.00

Angle Clamp

Clamps two sheet metal pieces of the same thickness at 90° to one another.

Jaw width: 50mm.
Throat depth: 15mm.



Capacity (mm)	Overall Length	Weight each	Order Code	Price/1 TB
0 - 12	200mm (8")	495g	-9230K	1597.00

HAND TOOLS

SENATOR *Sheet Metal Clamp*



The wide jaws distribute the clamping force evenly to prevent damaging the workpiece being handled.

Overall length	Weight each	Order Code SEN-558	Price/1 TB
255mm (10")	700g	-7300K	648.00

Quick Release Lever

Welder's Clamp



Deep throated, suitable for clamping sheet metal, body panels and sills, with split jaws to allow maximum visibility and access to the working area when welding.

Overall Length	Weight each	Order Code SEN-558	Price/1 TB
205mm (8")	680g	-7500K	471.00

Quick Release Lever

Locking C-Clamps



Wide and deep jaw profile, clear obstacles to firmly clamp sections that a normal grip wrench cannot.

Overall length	Weight each	Order Code SEN-558	Price/1 TB
150mm (6")	185g	-7360K	452.00
280mm (11")	800g	-7410K	463.00

Quick Release Lever

Adjustable Bar Clamp

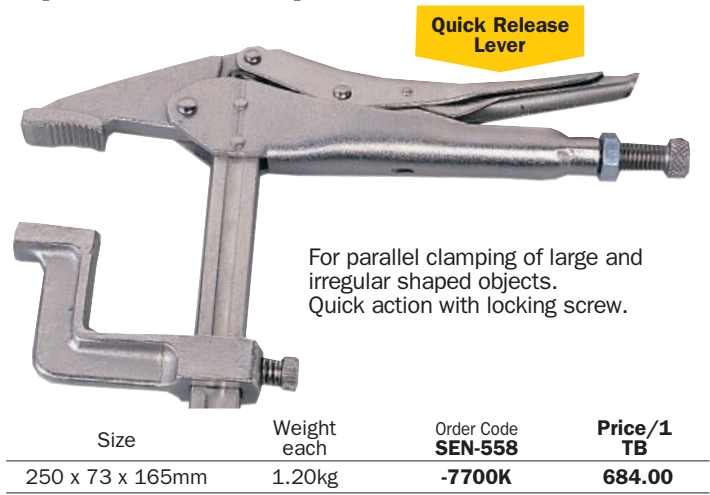

For parallel clamping of large and irregular shaped objects. Quick action with locking screw.

Size	Weight each	Order Code SEN-558	Price/1 TB
250 x 73 x 165mm	1.20kg	-7700K	684.00

Quick Release Lever

KENNEDY *Spindle Clamps*

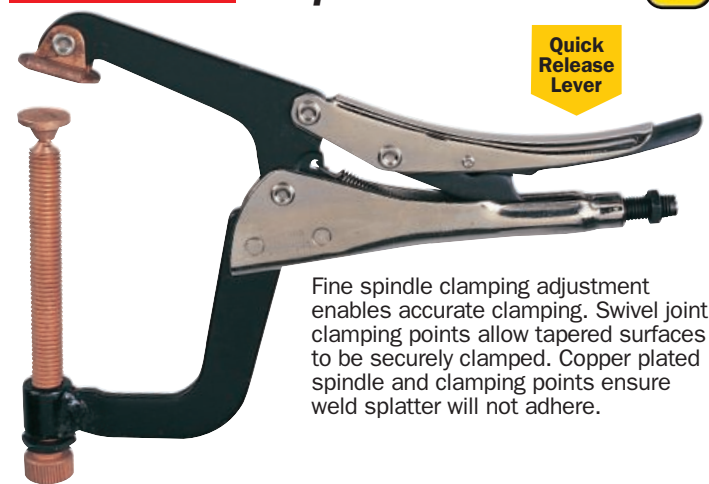

Fine spindle clamping adjustment enables accurate clamping. Swivel joint clamping points allow tapered surfaces to be securely clamped. Copper plated spindle and clamping points ensure weld splatter will not adhere.

Capacity (mm)	Overall length	Weight each	Order Code KEN-558	Price/1 TB
0 - 25	300mm	300g	-8720K	2575.00
0 - 100	330mm	800g	-8740K	2730.00

Quick Release Lever

Table C-Clamp

Five holes in base to allow fixture to work surface as a permanent clamp. Swivel foot to clamp tapered workpieces.



Capacity (mm)	Overall length	Weight each	Order Code KEN-558	Price/1 TB
0 - 100	300mm	880g	-8160K	2903.00

Quick Release Lever

Sill Clamps

The small gripping jaws allow close-up working. Deep throat enables access around bulky and awkward shapes such as door sills or holding together sheet metal, body panels when welding, gluing or marking off.

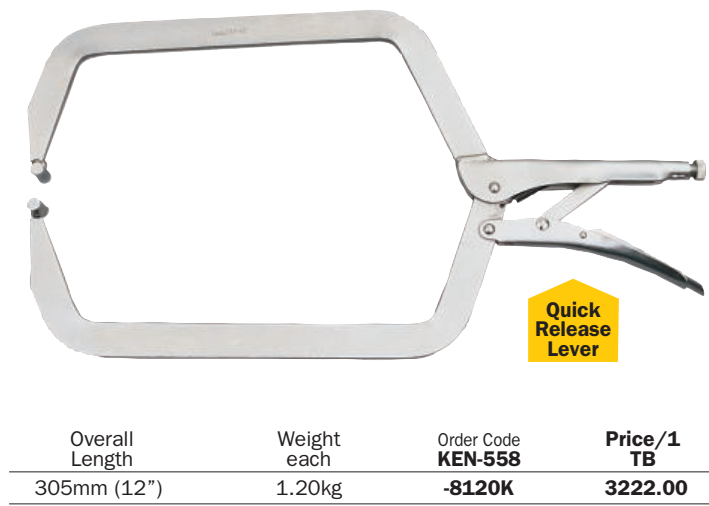

Overall Length	Weight each	Order Code KEN-558	Price/1 TB
305mm (12")	1.20kg	-8120K	3222.00

Quick Release Lever

HAND TOOLS

GROUP 560 PUNCHES & STAMPS

KENNEDY *Hand Stamps*
QUALITY INDUSTRIAL TOOLING

Drawn carbon steel nickel-plated hand stamps with chamfered edges to prevent accidental damage to workpiece.

Positive Indent (Standard)



Hand Stamp Sets



Set Description	Number of Pieces	Font Size (mm)	Overall Length	Weight each	Order Code KEN-560	Price/1 TB
Letter A - Z Plus &	27	1.5	73	1000g	-6400K	1858.00
		2.5	73	1000g	-6410K	1841.00
		3.0	73	1000g	-6420K	1841.00
		4.0	73	1000g	-6430K	2047.00
		5.0	78	1600g	-6440K	2163.00
		6.0	78	1600g	-6450K	2305.00
		8.0	80	3800g	-6460K	3695.00
		10.0	92	4000g	-6470K	4674.00
		12.0	92	4000g	-6480K	6064.00
Figure 0 - 9	9	1.5	71	330g	-6000K	743.00
		2.5	71	330g	-6010K	585.00
		3.0	71	340g	-6020K	585.00
		4.0	71	340g	-6030K	637.00
		5.0	75	540g	-6040K	720.00
		6.0	75	530g	-6050K	823.00
		8.0	83	1000g	-6060K	1327.00
		10.0	90	1400g	-6070K	1751.00
		12.0	90	1400g	-6080K	2282.00

Positive Indent Low Stress Punches

For use on brittle material to avoid damage.



Set Description	Number of Pieces	Font Size (mm)	Overall Length	Weight each	Order Code KEN-560	Price/1 TB
Letter	27	3.0	73	1000g	-7300K	4596.00
A - Z Plus &		6.0	78	1600g	-7600K	6670.00
Figure	9	3.0	71	330g	-5300K	1831.00
0 - 9		6.0	75	550g	-5600K	2869.00

HAND TOOLS

6 Wheel Number Punch

Ideal for rapid precise marking of six figure numbers in one impact. Manufactured from nickel-plated carbon steel, knurled handle for extra grip.



Font Size (mm)	Overall Length	Weight each	Order Code KEN-560	Price/1 TB
3.0	130	640g	-9000K	29870.00

SENATOR *Letter & Number Stamps*
QUALITY TOOLING



Standard quality, with strength up to 800N/mm². Hardness at the engraving: 58 - 60HRC. Type of characters according to DIN 1451.



Set Description	Number of Pieces	Font Size	Weight each	Order Code SEN-560	Price/1 TB
Numbers 0 - 9	9	3.0	550g	-1300K	735.00
		4.0	950g	-1400K	802.00
		5.0	1350g	-1500K	954.00
		6.0	1350g	-1600K	1028.00
		8.0	200g	-1800K	1411.00
		10.0	200g	-2100K	1766.00
Letters A - Z	27	3.0	550g	-3300K	2195.00
		4.0	950g	-3400K	2389.00
		5.0	1350g	-3500K	2855.00
		6.0	1350g	-3600K	2823.00
		8.0	200g	-3800K	4214.00
		10.0	200g	-4100K	5612.00



Precision manufactured carbon steel alphabetical and numeric-marking stamps with nickel-plated finish. For producing between eight and ten clean uniform impressions in one impact, suitable for all batch and general-purpose marking. Each set contains tweezers to allow easy handling of the individual font blocks. The knurled grip font holder has an impact resistant plastic hand shield to redirect the force of miss-hits safely away from your hand preventing injury. Hexagon wrench for operating the font retaining screw and 100 characters and spaces according to the most common use. See diagram for exact character content. Supplied complete in a foam-lined plastic carry case.

Individual Nickel-Plated Carbon Steel Fonts

For use with holder shown below. 3mm character height.

Character	Order Code KEN-560	Price/1 TB
Alphabetical		
A	-8200K	140.00
B	-8210K	140.00
C	-8220K	140.00
D	-8230K	140.00
E	-8240K	140.00
F	-8250K	140.00
G	-8260K	140.00
H	-8270K	140.00
I	-8280K	140.00
J	-8290K	140.00
K	-8300K	140.00
L	-8310K	140.00
M	-8320K	140.00
N	-8330K	140.00
O	-8340K	140.00
P	-8350K	140.00
Q	-8360K	140.00
R	-8370K	140.00
S	-8380K	140.00
T	-8390K	140.00
U	-8400K	140.00
V	-8410K	140.00
W	-8420K	140.00
X	-8430K	140.00
Y	-8440K	140.00
Z	-8450K	140.00
Space	-8500K	123.00
Numeric		
0	-8100K	140.00
1	-8110K	140.00
2	-8120K	140.00
3	-8130K	140.00
4	-8140K	140.00
5	-8150K	140.00
6	-8160K	140.00
7	-8170K	140.00
8	-8180K	140.00
9	-8190K	140.00

**100
PIECES**

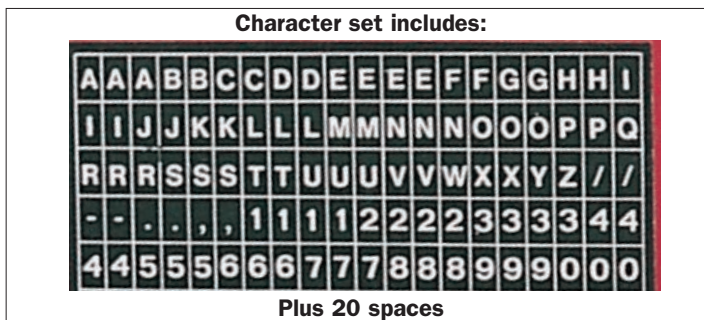

Set					Individual Holder			
Number of Pieces	Font Size	Weight each	Order Code KEN-560	Price/1 TB	Overall Length	Weight each	Order Code KEN-560	Price/1 TB
100	3.0mm	1.50kg	-9300K	23278.00	125mm	600g	-9500K	8399.00

Power Punch Kit

Provides smooth piercing with minimum effort. For use on steel, aluminium, plastic and leather. Adjustable depth gauge. Suitable for materials up to 14 gauge.

Die and punch sizes:
2.38, 3.18, 3.97,
4.76, 5.56, 6.35,
and 7.14mm.



Model Number	Throat Capacity	Weight each	Order Code KEN-560	Price/1 TB
PPK2812	45mm (1 3/4")	1.60kg	-7800K	3220.00

Spares

Size (mm)	Order Code KEN-560 Dies	Price/1 TB	Order Code KEN-560 Punches	Price/1 TB
2.38 (3/32")	-7910K	67.00	-7980K	67.00
3.18 (1/8")	-7920K	67.00	-7990K	67.00
3.97 (5/32")	-7930K	67.00	-8000K	67.00
4.76 (3/16")	-7940K	67.00	-8010K	67.00
5.56 (7/32")	-7950K	67.00	-8020K	67.00
6.35 (1/4")	-7960K	67.00	-8030K	67.00
7.14 (9/32")	-7970K	67.00	-8040K	67.00

Stencil Sets

Stencils manufactured from hard-wearing quality steel with precision cut letters for a clean sharp image. Suitable for use with all paints and marking compounds for marking packing cases with shipping details, loading/work bay walls for identification, car park spaces and countless other applications.

10-Piece Numbered Sets 0 - 9 26-Piece Letter Sets A - Z



Character Height	Weight each	Order Code KEN-561	Price/1 TB	Character Height	Weight each	Order Code KEN-561	Price/1 TB
40mm	80g	-0400K	422.00	40mm	170g	-2400K	821.00
50mm	110g	-0500K	509.00	50mm	250g	-2500K	1176.00
60mm	130g	-0600K	567.00	60mm	300g	-2600K	1656.00
70mm	170g	-0700K	738.00	70mm	350g	-2700K	1671.00
80mm	200g	-0800K	761.00	80mm	440g	-2800K	1789.00
100mm	260g	-1000K	1121.00	100mm	600g	-3100K	2059.00
150mm	1000g	-1500K	2575.00	150mm	2400g	-3150K	4119.00
200mm	1400g	-2000K	3605.00	200mm	4500g	-3200K	6179.00

PRODUCTS ARE ONLY AVAILABLE VIA YOUR DISTRIBUTOR

HAND TOOLS

GROUP 569 RIVETING TOOLS

KENNEDY Heavy Duty Lever Action Riveter
QUALITY INDUSTRIAL TOOLING



Produces strong, vibration proof joints effortlessly. Replaces screws, bolts, ordinary rivets, brazing, soldering and welding. Moulded comfort grip. Long nose design, ideal for use in recessed areas. With enamelled steel body with storage for four nozzles and quick change wrench.

Supplied with nozzels: 2.4, 3.2, 4.0 and 4.8mm.

Supplied with 60 assorted aluminium rivets: 2.4mm (3/32"), 3.2mm (1/8"), 4.0mm (5/32") and 4.8mm (3/16").

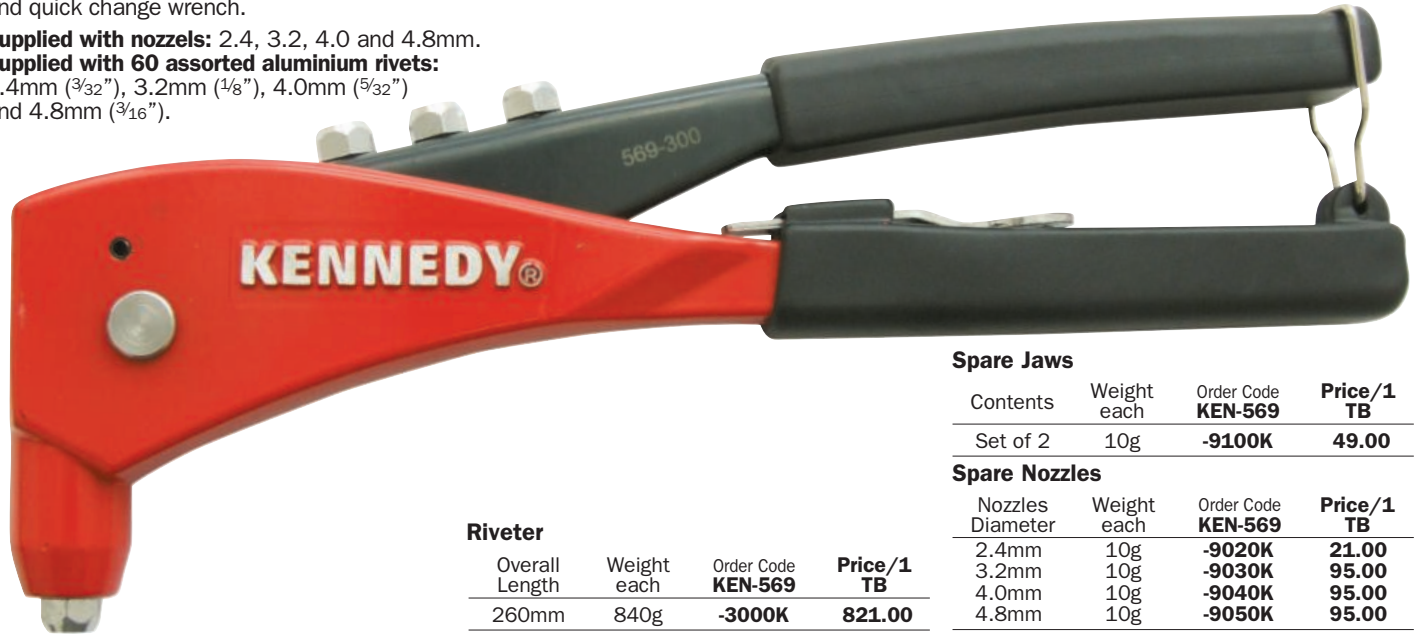

Spare Jaws

Contents	Weight each	Order Code KEN-569	Price/1 TB
Set of 2	10g	-9100K	49.00

Spare Nozzles

Nozzles Diameter	Weight each	Order Code KEN-569	Price/1 TB
2.4mm	10g	-9020K	21.00
3.2mm	10g	-9030K	95.00
4.0mm	10g	-9040K	95.00
4.8mm	10g	-9050K	95.00

Riveter

Overall Length	Weight each	Order Code KEN-569	Price/1 TB
260mm	840g	-3000K	821.00

Rivet Nut Inserter

Model RNI410

This sturdy professional quality tool has been designed for the insertion of rivet nuts into sheet metal. It has a cast body with a corrosion-resistant powder-coated finish, heavy-duty steel levers with soft grips for user comfort and a knurled adjustment ring for material thickness setting. It also has a pump action mandrel turning shaft for quick loading of fasteners.

Includes:

Set of five nose piece kits, M4, 5, 6, 8 and 10 plus instruction manual.



Spare Nose Piece Sets

Contents	Order Code KEN-569	Price/1 TB
M4	-9300K	823.00
M5	-9310K	823.00
M6	-9320K	823.00
M8	-9330K	823.00
M10	-9340K	823.00

Nozzles Supplied	Order Code KEN-569	Price/1 TB
M4, 5, 6, 8 & 10	-3080K	8252.00

KOBE Rivet Nut Attachment

This attachment has been specifically designed to insert rivet nuts into sheet metal. Rapid loading of inserts improves productivity. 1/4" hex drive makes it suitable for use with cordless, electric or air screwdrivers. Robust moulded polycarbonate body with fluted sides for extra grip. 26mm hexagonal moulding for gripping with a suitable wrench. Complete with a set of three threaded mandrels, M4, M5 and M6.



Body Length	Weight each	Order Code KBE-280	Price/1 TB
125mm	245g	-0100A	2652.00

HAND TOOLS

KENNEDY Industrial
QUALITY INDUSTRIAL TOOLING **Lazy Tong Riveter**

The powerful one-handed compression action and all steel construction make this ideal for rapid, repetitive rivetting applications. The contoured handle provides a comfortable grip for the user and reduces fatigue. In-handle storage of different nozzle sizes ensures rapid nozzle changing when required.

Length closed: 300mm. **Extended:** 825mm.

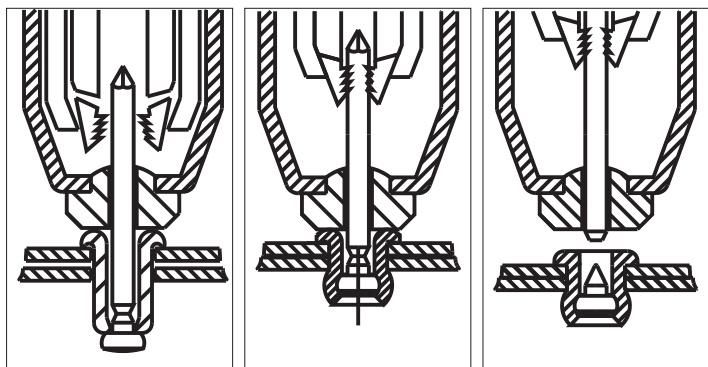
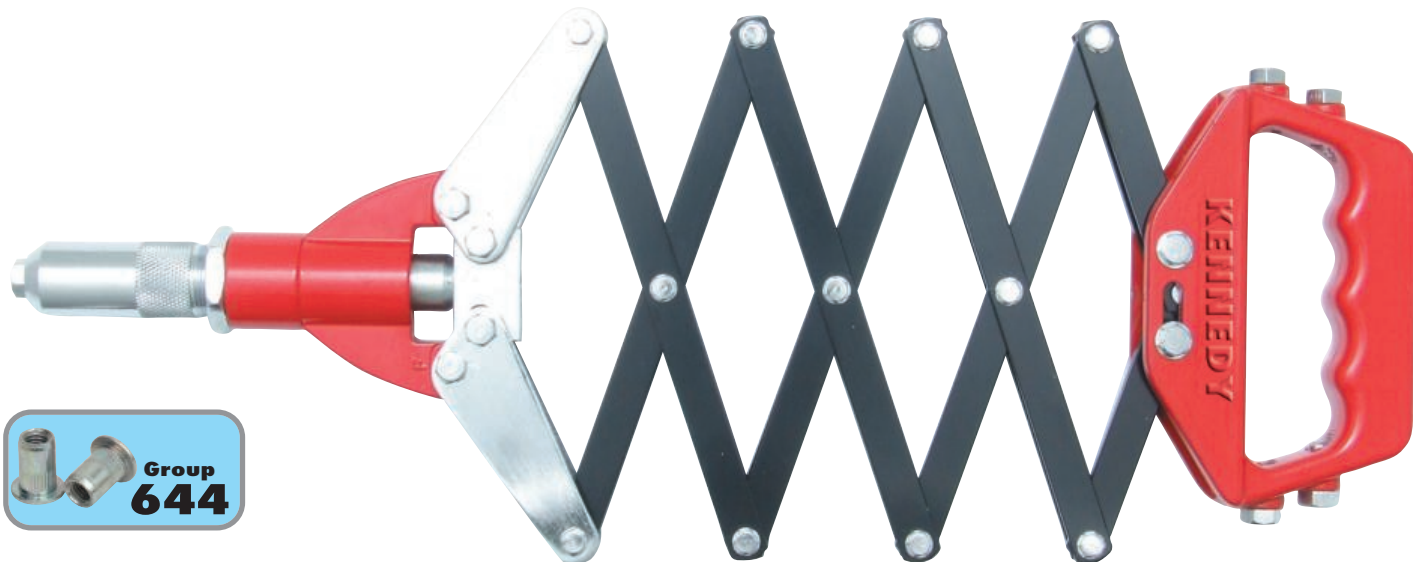
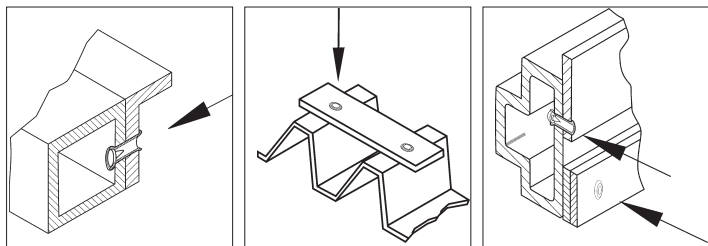

Lazy Tong Riveter	Nozzles Supplied	Weight each	Order Code	Price/1 TB
3.2, 4, 4.8, 6.0 & 6.4mm	2.30kg	-3020K	3416.00	

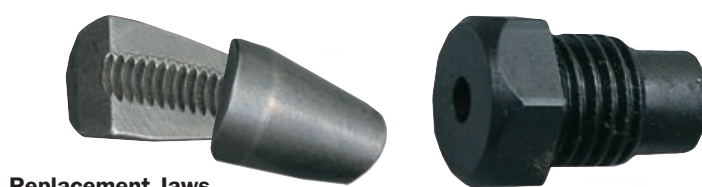

Replacement Jaws			
Contents	Weight each	Order Code	Price/1 TB
Set of 3	10g	-9120K	109.00
Replacement Nozzles			
Contents	Weight each	Order Code	Price/1 TB
3.2mm	10g	-9070K	40.00
4.0mm	10g	-9080K	40.00
4.8mm	10g	-9090K	40.00
6.0mm	10g	-9092K	40.00
6.4mm	10g	-9094K	40.00

Long Arm Riveter

High leverage for effortless setting of rivets. Comfortable rubber hand grips. effortless setting of rivets. Complete with 'catcher'.

Supplied with the following sizes of nozzle:

3.2mm (1/8"), 4.0mm (5/32"), 4.8mm (3/16"), 5.5mm (7/32") and 6.4mm (1/4").

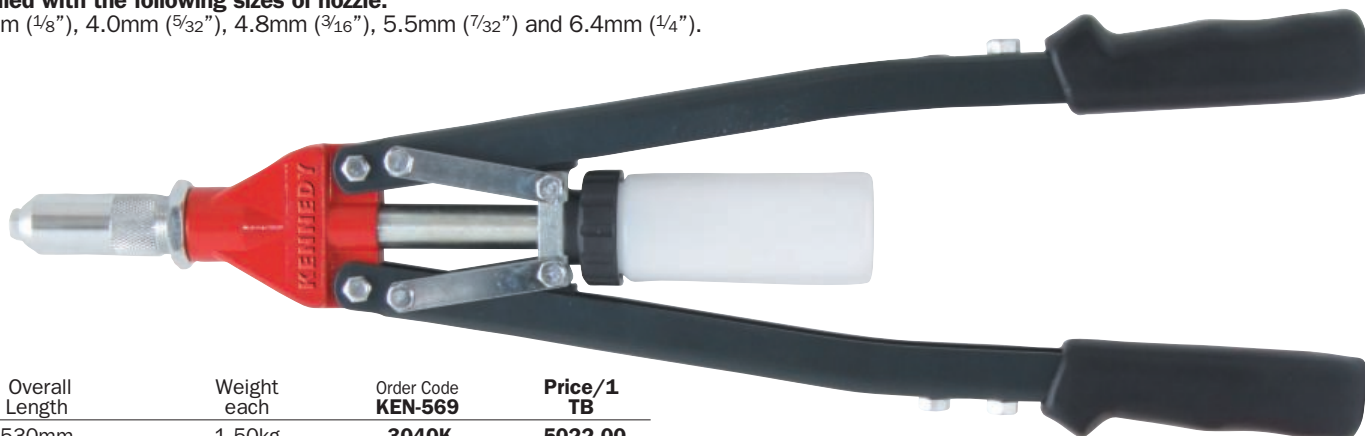

Overall Length	Weight each	Order Code	Price/1 TB
530mm	1.50kg	-3040K	5022.00

PRODUCTS ARE ONLY AVAILABLE VIA YOUR DISTRIBUTOR

HAND TOOLS

GROUP 572 SCREWDRIVERS

KENNEDY PROFESSIONAL Pro-Torq Screwdrivers

Chrome vanadium steel blades with magnetic tips. Fitted with a unique dual grip triangular handle which has been designed for improved user comfort,



allowing more torque to be applied. With convenient hanging hole in the handle for storage.

Crosspoint

Crosspoint screws virtually eliminate the screwdriver slippage if the correct size is used. The No.2 screwdriver would be suitable for most applications. **DIN ISO 8764.**



Tip Size	Blade Length	Weight each	Order Code KEN-572	Price/1 TB
No.0	75mm	25g	-5110K	181.00
No.1	75mm	55g	-5120K	182.00
No.1	250mm	80g	-4490K	232.00
No.2	Stubby	40g	-5180K	170.00
No.2	100mm	85g	-5140K	189.00
No.2	250mm	120g	-4500K	232.00
No.3	150mm	145g	-5150K	302.00
No.4	200mm	210g	-5160K	352.00

PZ/Supadriv

PZ/Supadriv has extra 'cutaways' to help drive the screw. Favoured by the construction and joinery trade. **DIN ISO 8764.**



Tip Size	Blade Length	Weight each	Order Code KEN-572	Price/1 TB
No.2	Stubby	45g	-5280K	154.00
No.0	75mm	25g	-5290K	131.00
No.1	75mm	55g	-5300K	185.00
No.1	250mm	80g	-5360K	256.00
No.2	100mm	85g	-5310K	226.00
No.2	250mm	120g	-5370K	266.00
No.3	150mm	145g	-5320K	308.00
No.4	200mm	210g	-5340K	400.00

Parallel Tip

To safely drive these screws, the tip of the screwdriver should be of the same width as the slot in the screw head and fill it as well, to minimise slipping and deforming the screw head. **DIN ISO 2380.**



Tip Size	Blade Length	Weight each	Order Code KEN-572	Price/1 TB
3.2mm	100mm	25g	-5650K	117.00
3.2mm	150mm	30g	-5660K	173.00
4.0mm	300mm	50g	-5400K	280.00
5.5mm	75mm	55g	-5710K	185.00
5.5mm	100mm	60g	-5720K	190.00
5.5mm	150mm	65g	-5730K	199.00
5.5mm	200mm	75g	-5740K	233.00
5.5mm	250mm	80g	-5750K	271.00
5.5mm	260mm	81g	-5404K	306.00

HAND TOOLS

Flared Tip, Round Blade

To safely drive these screws, the tip of the screwdriver should be of the same width as the slot in the screw head and fill it as well, to minimise slipping and deforming the screw head. **DIN ISO 2380.**



Tip Size	Blade Length	Weight each	Order Code KEN-572	Price/1 TB
3.2mm	75mm	25g	-5425K	131.00
6.5mm	Stubby	40g	-5420K	170.00
6.5mm	100mm	85g	-5430K	226.00
6.5mm	150mm	100g	-5440K	239.00
8.0mm	200mm	170g	-5450K	335.00
10.0mm	250mm	240g	-5460K	432.00

Flared Tip, Square Blade

Square bladed screwdrivers can be gripped in a spanner or locking wrench to allow greater torque to be applied from the side rather than from directly above the screwdriver. **DIN ISO 2380.**



Tip Size	Blade Length	Weight each	Order Code KEN-572	Price/1 TB
6.5mm	100mm	90g	-5500K	183.00
6.5mm	150mm	105g	-5510K	192.00
8.0mm	200mm	185g	-5520K	253.00
10.0mm	250mm	275g	-5530K	350.00
10.0mm	300mm	305g	-5550K	377.00

TX

TX head screws are used predominantly for engineering and automotive applications. The design of the screw allows high torque levels to be applied without the driver slipping potentially damaging the components.



Tip Size	Blade Length	Weight each	Order Code KEN-572	Price/1 TB
T6	75mm	30g	-5260K	126.00
T7	75mm	30g	-5262K	126.00
T8	75mm	30g	-5264K	126.00
T9	75mm	30g	-5266K	122.00
T10	100mm	60g	-5268K	157.00
T15	100mm	60g	-5270K	157.00
T20	100mm	25g	-5272K	157.00
T25	100mm	85g	-5274K	189.00
T30	100mm	85g	-5276K	189.00

KENNEDY 'Hi-Grip' Pound Thru' Screwdrivers

Through blade screwdriver with chrome vanadium steel blades and striking heads, suitable for striking with a hammer to free up seized screws. Fully hardened magnetic tips. Comfortable moulded grip. Hexagon blades. **DIN ISO 2380/8764.**



Crosspoint

Crosspoint screws virtually eliminate the screwdriver slippage if the correct size is used. The No.2 screwdriver would be suitable for most applications. **DIN ISO 8764.**

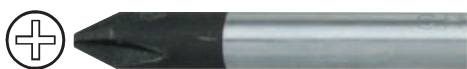

Tip Size	Blade Length	Weight each	Order Code KEN-572	Price/1 TB
No.1	75mm	100g	-3610K	154.00
No.2	100mm	150g	-3620K	209.00
No.3	150mm	220g	-3630K	253.00

Flared Tip

Slotted head screws are the most commonly used screw. To safely drive these screws, the tip of the screwdriver should be of the same width as the slot in the screw head and fill it as well, to minimise slipping and deforming the screw head. Hexagon blades. **DIN ISO 2380.**



Tip Size	Blade Length	Weight each	Order Code KEN-572	Price/1 TB
6mm	100mm	150g	-3510K	215.00
6mm	150mm	160g	-3520K	230.00
8mm	200mm	240g	-3540K	286.00
9.5mm	250mm	315g	-3560K	384.00

KENNEDY Pound Thru' Set



Supplied in display box.

- CROSS POINT
 - No.1 x 75,
 - No.2 x 100,
 - No.3 x 150.
- FLARED
 - 6 x 100,
 - 6 x 150,
 - 8 x 200,
 - 9.5 x 250mm.



Number of Pieces	Weight each	Order Code KEN-572	Price/1 TB
7	1.54kg	-3700K	1919.00



KENNEDY PROFESSIONAL Pro-Torq Screwdrivers

Chrome vanadium steel blades with magnetic tips. Fitted with a unique dual grip triangular handle designed for improved user comfort, allowing more torque to be applied. Manufactured with hanging hole in the handle for storage. **DIN ISO 2380/8764.**

6-Piece Set Contents (mm):

Crosspoint: No.1 x 75, No.2 x 100.

Flared: 6.3 x 100, 8.0 x 200.

Parallel: 5.0 x 75, 5.0 x 150.

6
PIECES



Number of Pieces	Weight each	Order Code KEN-572	Price/1 TB
6	810g	-5970K	1363.00

8-Piece Set Contents (mm):

Crosspoint: No.1 x 75, No.2 x 100.

PZ: No.2 x 100.

Flared: 6.3 stubby, 6.3 x 100, 8.0 x 200.

Parallel: 5.0 x 75, 5.0 x 150.

8
PIECES



Number of Pieces	Weight each	Order Code KEN-572	Price/1 TB
8	1010g	-6000K	1746.00

12-Piece Set Contents (mm):

Crosspoint: No.2 x stubby, No.1 x 75, No.2 x 100, No.3 x 150.

PZ: No.2 x 100, No.3 x 150.

Flared: 6.3 x stubby, 6.3 x 150, 8.0 x 200.

Parallel: 5.0 x 75, 5.0 x 150, 5.0 x 250.

12
PIECES



Number of Pieces	Weight each	Order Code KEN-572	Price/1 TB
12	1467g	-6030K	2971.00

6-Piece Set Contents (mm):

PZ: No.1 x 75, No.2 x 100.

Flared: 6.5 x 150, 10.0 x 250.

Parallel: 5.5 x 100, 5.5 x 200.

6
PIECES



Number of Pieces	Weight each	Order Code KEN-572	Price/1 TB
6	925g	-5975K	1506.00

8-Piece Set Contents (mm):

Crosspoint: No.2 x stubby, No.2 x 100.

PZ: No.1 x 75, No.2 x 100, No.3 x 150.

Flared: 6.3 x 150, 8.0 x 200.

Parallel: 5.0 x 150.

8
PIECES



Number of Pieces	Weight each	Order Code KEN-572	Price/1 TB
8	1105g	-6010K	1895.00

12-Piece Set Contents (mm):

Crosspoint: No.1 x 75, No.2 x stubby, No.2 x 100.

Flared: 6.3 x stubby, 6.3 x 100, 6.3 x 150, 8.0 x 200, 9.5 x 250.

Parallel: 5.0 x 75, 5.0 x 100, 5.0 x 200, 5.0 x 250.

12
PIECES



Number of Pieces	Weight each	Order Code KEN-572	Price/1 TB
12	1581g	-6040K	2749.00

8-Piece Set Contents (mm):

Crosspoint: No.1 x 75, No.2 x 100, No.3 x 150.

PZ: No.2 x 100.

Flared: 6.3 x 150, 9.5 x 250.

Parallel: 5.0 x 100, 5.0 x 200.

8
PIECES



Number of Pieces	Weight each	Order Code KEN-572	Price/1 TB
8	1280g	-5990K	2031.00

12-Piece Set Contents (mm):

Crosspoint: No.2 x stubby, No.2 x 100, No.3 x 150.

PZ: No.1 x 75 No.2 x 100 No.3 x 150.

Flared: 6.3 x stubby, 6.3 x 150, 9.5 x 250.

Parallel: 5.0 x 100, 5.0 x 200, 5.0 x 250.

12
PIECES



Number of Pieces	Weight each	Order Code KEN-572	Price/1 TB
12	1660g	-6020K	2865.00

9-Piece TX Set Contents (mm):

TX: T6 x 75, T7 x 75, T8 x 75, T9 x 75, T10 x 100, T15 x 100, T20 x 100, T25 x 100, T30 x 100.

9
PIECES



Number of Pieces	Weight each	Order Code KEN-572	Price/1 TB
9	790g	-6050K	2018.00



HAND TOOLS

GROUP 572 SCREWDRIVERS

KENNEDY *Engineer's & Electrician's Screwdrivers*
 QUALITY INDUSTRIAL TOOLING



With a traditional 'fluted' design handle. High quality steel blades with satin finish. Magnetic tips, hardened and ground to prolong tool life. This range offers the widest choice of blade selection and blade length. The high impact plastic handles are acid and oil resistant. A comprehensive selection to meet the demands of modern industry.
DIN ISO 2380/8764.



Crosspoint

Crosspoint screws virtually eliminate the screwdriver slippage if the correct size is used. The No.2 driver is suitable for most applications. **DIN ISO 8764.**



Tip Size	Blade Length	Weight each	Order Code KEN-572	Price/1 TB
No.0	75	25g	-1000K	93.00
No.1	75	55g	-1010K	124.00
No.2	100	80g	-1020K	146.00
No.3	150	135g	-1030K	212.00
No.4	200	225g	-1040K	324.00
No.1 Stubby	60g		-1210K	124.00
No.2 Stubby	60g		-1220K	124.00

PZ/Supadriv

PZ/Supadriv has extra 'cutaways' to help drive the screw. Favoured by the construction and joinery trade. **DIN ISO 8764.**



Tip Size	Blade Length	Weight each	Order Code KEN-572	Price/1 TB
No.0	75	25g	-2000K	93.00
No.1	75	55g	-2010K	124.00
No.1	250	80g	-2510K	146.00
No.2	100	80g	-2020K	146.00
No.2	250	110g	-2520K	189.00
No.3	150	135g	-2030K	212.00
No.3	250	175g	-2530K	265.00
No.4	200	225g	-2040K	324.00
No.1 Stubby	60g		-2210K	124.00
No.2 Stubby	55g		-2220K	124.00

Flared Tip, Round Blade

Same as the parallel tip. **DIN ISO 2380.**



Tip Size	Blade Length	Weight each	Order Code KEN-572	Price/1 TB
6.5mm Stubby	60g		-3020K	125.00
6.5mm	100	80g	-3040K	149.00
6.5mm	150	90g	-3060K	159.00
8.0mm	200	155g	-3080K	242.00
10.0mm	250	250g	-3100K	357.00
10.0mm	300	280g	-3120K	384.00

Parallel Tip

Slotted head screws are the most commonly used screw. To safely drive these screws, the tip of the screwdriver should be of the same width as the slot in the screw head and fill it as well, to minimise slipping and deforming the screw head. **DIN ISO 2380.**



Tip Size	Blade Length	Weight each	Order Code KEN-572	Price/1 TB
3.2mm	50	25g	-4520K	109.00
3.2mm	75	25g	-4530K	91.00
3.2mm	100	25g	-4540K	96.00
3.2mm	150	30g	-4560K	109.00
5.5mm	75	55g	-5030K	139.00

Tip Size	Blade Length	Weight each	Order Code KEN-572	Price/1 TB
5.5mm	100	55g	-5040K	142.00
5.5mm	150	65g	-5060K	144.00
5.5mm	200	70g	-5080K	157.00
5.5mm	250	80g	-5100K	173.00

Flared Tip, Square Blade

Square bladed screwdrivers can be gripped in a spanner or locking wrench to allow greater torque to be applied from the side rather than from directly above the screwdriver. **DIN ISO 2380.**

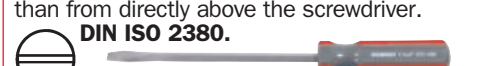

Tip Size	Blade Length	Weight each	Order Code KEN-572	Price/1 TB
6.5mm	100	85g	-4040K	134.00
6.5mm	150	95g	-4060K	134.00
8.0mm	200	175g	-4080K	215.00
10.0mm	250	285g	-4100K	252.00

HAND TOOLS

Set Contents (mm):

- FLARED
6.5 stubby, 6.5 x 100, 6.5 x 150, 10.0 x 250.
- PARALLEL
3.2 x 100, 5.5 x 150.
- PZ
No.1 stubby, No.1 x 75, No.2 stubby, No.2 x 100, No.3 x 150.

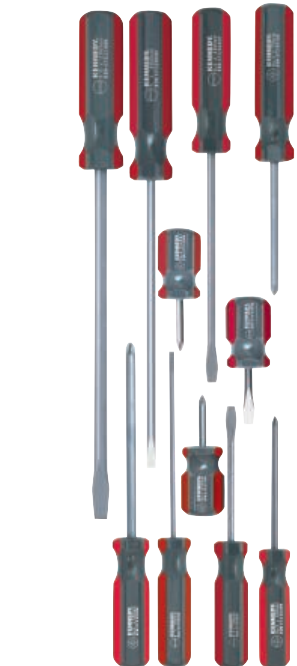

**11
PIECES**

Number of Pieces	Weight each	Order Code KEN-572	Price/1 TB
11	1.0kg	-9900K	1592.00

Set Contents (mm):

- FLARED
6.5 stubby, 6.5 x 100, 8.0 x 200, 10.0 x 250.
- PARALLEL
3.2 x 75, 3.2 x 150, 5.5 x 75, 5.5 x 150.
- CROSS POINT
No.0 x 75, No.1 stubby, No.1 x 75, No.2 stubby, No.2 x 100, No.3 x 150, No.4 x 200.

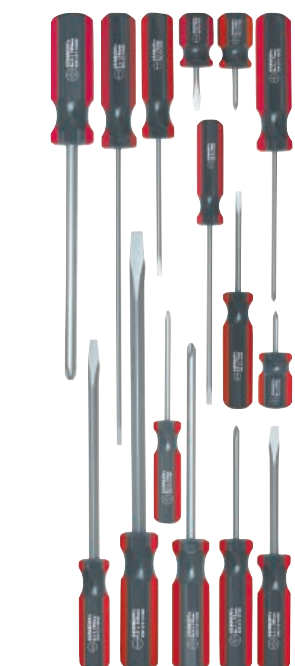

**15
PIECES**

Number of Pieces	Weight each	Order Code KEN-572	Price/1 TB
15	1.39kg	-9920K	2415.00

Set Contents (mm):

- FLARED
6.5 stubby, 6.5 x 100, 8.0 x 200.
- PARALLEL
3.2 x 75, 3.2 x 150.
- CROSS POINT
No.0 x 75, No.1 stubby, No.1 x 75, No.2 stubby, No.2 x 100, No.3 x 150, No.4 x 200.

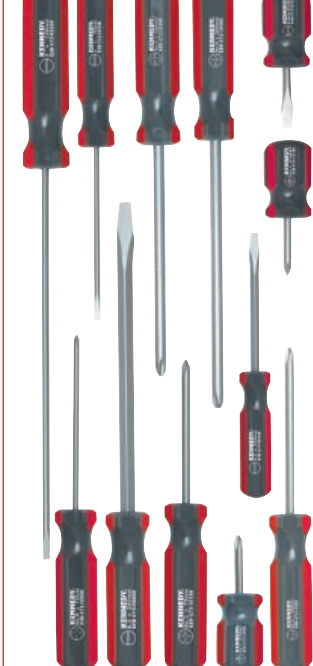

**12
PIECES**

Number of Pieces	Weight each	Order Code KEN-572	Price/1 TB
12	1.05kg	-5940K	1682.00



KENNEDY 'Hi-Grip'
QUALITY INDUSTRIAL TOOLING® Screwdrivers

Designed for maximum grip under load application. The red moulded cushion grip gives optimum operator comfort. Ideal for assembly work. Tough alloy steel blades with satin finish. Magnetic tips, hardened and ground to prolong tool life. **DIN ISO 2380/8764.**



*Flat blades have hexagon bolster to allow higher torque to be applied via a spanner.

Crosspoint

Crosspoint screws virtually eliminate the screwdriver slippage if the correct size is used. The No.2 driver is suitable for most applications. **DIN ISO 8764.**



Tip Size	Blade Length	Weight each	Order Code KEN-572	Price/1 TB
No.0	75mm	35g	-0000K	83.00
No.1	75mm	75g	-0010K	154.00
No.2	100mm	110g	-0020K	197.00
No.3	150mm	170g	-0030K	274.00
No.2	Stubby	65g	-0120K	144.00

PZ/Supadriv

PZ/Supadriv has extra 'cutaways' to help drive the screw. Favoured by the construction and joinery trade. **DIN ISO 8764.**



Tip Size	Blade Length	Weight each	Order Code KEN-572	Price/1 TB
No.1	75mm	75g	-0210K	159.00
No.2	100mm	110g	-0220K	201.00
No.3	150mm	170g	-0230K	265.00

Flared Tip, Round Blade

Slotted head screws are the most commonly used screw. To safely drive these screws, the tip of the screwdriver should be of the same width as the slot in the screw head and fill it as well, to minimise slipping and deforming the screw head. **DIN ISO 2380.**



Tip Size	Blade Length	Weight each	Order Code KEN-572	Price/1 TB
6.5mm	Stubby	65g	-0320K	141.00
6.5mm	100mm	115g	-0340K	227.00
6.5mm	150mm	125g	-0360K	244.00
8.0mm	200mm	195g	-0380K	324.00
10.0mm	250mm	265g	-0400K	423.00

TX

TX head screws are used predominantly for engineering and automotive applications. The design of the screw allows high torque levels to be applied without the driver slipping potentially damaging the components.



Tip Size	Blade Length	Weight each	Order Code KEN-572	Price/1 TB
T6	75mm	40g	-6060K	133.00
T7	75mm	40g	-6070K	133.00
T8	75mm	40g	-6080K	124.00
T9	75mm	40g	-6090K	124.00
T10	75mm	40g	-6100K	124.00
T15	100mm	80g	-6150K	149.00
T20	100mm	800g	-6200K	149.00
T25	100mm	110g	-6250K	184.00
T30	100mm	110g	-6300K	184.00

Set Contents (mm):

Supplied in clear plastic wallet.

- No.1 x 75, No.2 stubby, No.2 x 100, No.3 x 150.
- 6.5 stubby, 6.5x100, 6.5x150, 10.0x250.

8
PIECES

Set Contents (mm):

Supplied in clear plastic wallet.

- 6.5 stubby, 6.5x100, 6.5x150, 8.0x200 and 10.0x250.
- No.2 x 100, No.3 x 150.
- No.1 x 75, No.2 x 100, No.3 x 150.
- No.1 x 75, No.2 stubby,

12
PIECES

Number of Pieces	Weight each	Order Code KEN-572	Price/1 TB
8	1.05kg	-9870K	1165.00
12	1.58kg	-0490K	2483.00

Set Contents (mm):

Supplied in clear plastic wallet.

- T6 x 75, T7 x 75, T8 x 75, T9 x 75, T10 x 75, T15 x 100, T20 x 100, T25 x 100, T27 x 100, T30 x 100 and T40 x 100.

11
PIECES

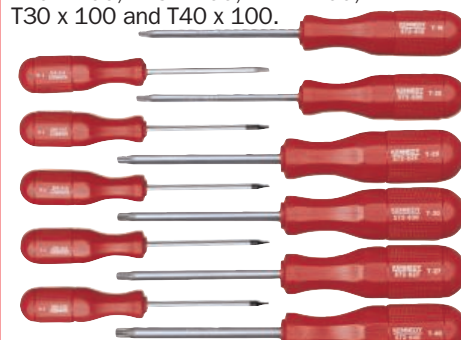

Number of Pieces	Weight each	Order Code KEN-572	Price/1 TB
11	830g	-6450K	1578.00

HAND TOOLS

Cabinet Screwdrivers

Traditional design cabinet screwdrivers with matt grey high impact plastic handles to ensure a firm yet comfortable grip allowing constant use, giving maximum torque. Chrome alloy steel blades with satin finish. Magnetic tips, hardened and ground to prolong tool life.

DIN ISO 2380/8764.

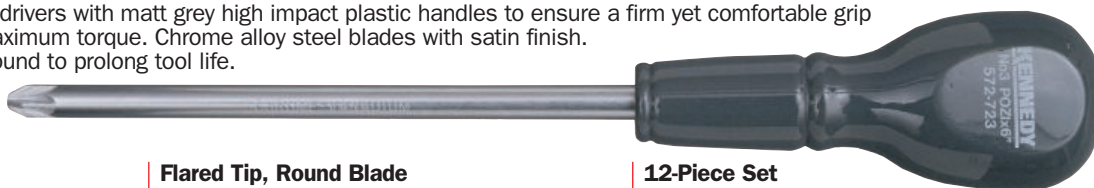

Crosspoint

Crosspoint screws virtually eliminate the screwdriver slippage if the correct size is used. The No.2 screwdriver would be suitable for most applications. **DIN ISO 8764.**



Tip Size	Blade Length	Weight each	Order Code KEN-572	Price/1 TB
No.1	75mm	65g	-7010K	160.00
No.2	100mm	90g	-7020K	160.00
No.3	150mm	165g	-7030K	175.00

Flared Tip, Round Blade

Slotted head screws are the most commonly used screw. To safely drive these screws, the tip of the screwdriver should be of the same width as the slot in the screw head and fill it as well, to minimise slipping and deforming the screw head. **DIN ISO 2380.**



Tip Size	Blade Length	Weight each	Order Code KEN-572	Price/1 TB
6.5mm	Stubby	55g	-7320K	85.00
5.5mm	75mm	65g	-7330K	85.00
6.5mm	100mm	90g	-7340K	96.00
6.5mm	150mm	105g	-7360K	134.00
8.0mm	200mm	185g	-7380K	205.00
10.0mm	250mm	250g	-7400K	252.00

12-Piece Set

Contents (mm):
Supplied in clear plastic wallet.

- No.1 x 75, No.2 x 100 and No.3 x 150.
- 5.5 x 75, 6.5 stubby, 6.5 x 100, 6.5 x 150, 8.0 x 200 and 10.0 x 250.
- No.1 x 75, No.2 x 100 and No.3 x 150.

12
PIECES



Number of Pieces	Weight each	Order Code KEN-572	Price/1 TB
12	1.45kg	-7490K	1830.00

GROUP 572 SCREWDRIVERS

YAMOTO Tri-Line™ Screwdriver

NEW

Ergonomically designed handles which are dual material and three-sided for improved torque and reduced fatigue. Chrome vanadium steel blades with magnetic tips and a hanging hole in the handle.



Crosspoint

Tip Size	Blade Length	Weight each	Order Code YMT-572	Price/1 TB
No.1	75mm	64g	-3420K	155.00
No.1	100mm		-3440K	176.00
No.1	150mm		-3460K	181.00
No.1	200mm		-3480K	191.00
No.2	100mm	96g	-3500K	186.00
No.2	150mm		-3520K	191.00
No.2	200mm		-3540K	201.00
No.2	250mm		-3560K	232.00
No.2	300mm		-3580K	258.00

PZ/Supadriv

Tip Size	Blade Length	Weight each	Order Code YMT-572	Price/1 TB
No.2	100mm	96g	-3600K	205.00
No.2	200mm		-3620K	232.00

Parallel Tip

Tip Size	Blade Length	Weight each	Order Code YMT-572	Price/1 TB
3.0mm	75mm	36g	-2600K	62.00
5.0mm	150mm	76g	-2620K	124.00
5.0mm	200mm		-2640K	150.00
5.0mm	250mm		-2660K	176.00
6.0mm	200mm		-2700K	176.00

Flared Tip

Tip Size	Blade Length	Weight each	Order Code YMT-572	Price/1 TB
6.0mm	Stubby	44g	-2740K	88.00
6.0mm	150mm	106g	-2800K	155.00
6.0mm	200mm		-2820K	176.00
6.0mm	250mm		-2840K	191.00
6.0mm	300mm		-2860K	205.00
8.0mm	150mm		-2880K	212.00
8.0mm	200mm	176g	-2900K	232.00
8.0mm	250mm		-2920K	258.00
8.0mm	300mm		-2940K	284.00
10.0mm	250mm		-2960K	411.00

Tri-Line Screwdriver Sets

8-Piece Set Contents (mm):

CROSS POINT	No.1 x 75, No.2 x 100.	PARALLEL	3 x 75, 5 x 150.
PZ	No.2 x 100.	FLARED	6 x 150, 8 x 200, 6 x stubby.

6-Piece Set Contents (mm):

CROSS POINT	No. 1 x 75, No. 2 x 100.		
PARALLEL	3 x 75, 5 x 150.		
FLARED	6 x 150, 8 x 200.		
Number of Pieces	Weight each	Order Code YMT-572	Price/1 TB
6	715g	-2060K	670.00
8	875g	-2080K	773.00

HAND TOOLS

YAMOTO Mechanic's Screwdrivers

Featuring a classic slimline design favoured by the automotive industry. Black high impact plastic handles. Chrome finish alloy steel blades with satin finish. Magnetic tips, hardened and ground to prolong tool life. Flat blades have hexagon bolster to allow extra torque to be applied using a spanner.



Crosspoint

Tip Size	Blade Length	Weight each	Order Code YMT-572	Price/1 TB
No.1	75mm	45g	-0510K	83.00
No.2	100mm	75g	-0520K	109.00
No.3	150mm	130g	-0530K	158.00
No.2	Stubby	50g	-0620K	83.00

PZ/Supadriv

Tip Size	Blade Length	Weight each	Order Code YMT-572	Price/1 TB
No.1	75mm	45g	-0710K	95.00
No.2	100mm	85g	-0720K	101.00
No.3	150mm	150g	-0730K	158.00

Flared Tip, Round Blade

Tip Size	Blade Length	Weight each	Order Code YMT-572	Price/1 TB
6.5mm	Stubby	50g	-0820K	70.00
6.5mm	100mm	80g	-0840K	101.00
6.5mm	150mm	90g	-0860K	158.00
8.0mm	200mm	155g	-0880K	209.00
10.0mm	250mm	250g	-0900K	265.00

Parallel Tip

Tip Size	Blade Length	Weight each	Order Code YMT-572	Price/1 TB
4.0mm	300mm	71g	-0320K	105.00
5.5mm	250mm	81g	-0340K	137.00
5.5mm	425mm	121g	-0350K	274.00
3 Piece Set		319g	-0400K	437.00

8-Piece Set Contents (mm):
Supplied in clear plastic wallet.

FLARED	6.3 stubby, 6.3 x 100, 6.3 x 150, 8.3 x 200 and 9.5 x 250.
CROSS POINT	No.1 x 75, No.2 x 100 and No.3 x 150.

8 PIECES

Number of Pieces	Weight each	Order Code YMT-572	Price/1 TB
8	820g	-0980K	975.00

12-Piece Set Contents (mm):

Supplied in clear plastic wallet.

FLARED	6.3 stubby, 6.3 x 100, 6.3 x 150, 8.3 x 200 and 9.5 x 250.
PZ	No.1 x 75, No.2 x 100 and No.3 x 150.
CROSS POINT	No.1 x 75, No.2 stubby, No.2 x 100 and No.3 x 150.

12 PIECES

Number of Pieces	Weight each	Order Code YMT-572	Price/1 TB
12	1.21kg	-0990K	1698.00



KENNEDY *Screwdriver Set*
QUALITY INDUSTRIAL TOOLING

Combined & Fluted Handle Screwdriver Set



Seven 'volt-tested' screwdrivers plus five non-insulated engineer's and electrician's screwdrivers. Supplied in clear plastic wallet

12 PIECES

12-Piece Set Contents (mm): Non-Insulated

-  6.3 stubby.
-  4.8 x 75, 4.8 x 150 and 4.8 x 250.

Volt-Tested



-  2.5 x 85, 4.0 x 100, 5.5 x 125 and 6.5 x 150.
-  No.2 x 1/4" slotted offset. No.0 x 75, No.1 x 100, No.2 x 100.

Number of Pieces	Weight each	Order Code KEN-572	Price/1 TB
12	745g	-5920K	1445.00

Offset Double-Ended Screwdrivers

Designed to give access into otherwise restricted areas. A versatile tool suitable for use in many applications.





Size	Weight each	Order Code KEN-572	Price/1 TB
 No.1 x $\frac{3}{16}$ "	20g	-4210K	124.00
 No.2 x $\frac{1}{4}$ "	30g	-4220K	124.00
 No.3 x $\frac{5}{16}$ "	80g	-4230K	124.00
Set - 1 each of above	140g	-4250K	199.00

Mini Screwdrivers

Extra light duty screwdriver with magnetic tips. Designed for use on terminals and other electrical work.

N.B. Do not use on live circuits.





Size	Weight each	Order Code KEN-572	Price/1 TB
 No.0 x 65	10g	-5190K	56.00
 3.0mm x 65	10g	-5220K	47.00
 3.0mm x 100	10g	-5240K	50.00
Set - 1 each of above	35g	-5250K	170.00

SENATOR *Screwdriver Sets*
QUALITY TOOLING

Chrome vanadium steel blades with magnetic tips. Acrylic handles.

8-Piece Set Contents (mm):



-  6 stubby, 3 x 100 and 8 x 200.
-  3.2 x 75 and 4 x 150.
-  No.2 stubby, No.1 x 75 and No.2 x 100.

ACRYLIC GRIP HANDLES

8 PIECES

Number of Pieces	Weight each	Order Code SEN-572	Price/1 TB
8	690g	-9980K	617.00

12-Piece Set Contents (mm):



-  6 stubby, 6 x 100, 6 x 150, 8 x 200 and 9.5 x 250.
-  No.2 stubby, No.1 x 75, No.2 x 100 and No.3 x 150.
-  3.2 x 75, 4 x 150 and 4 x 200.

ACRYLIC GRIP HANDLES

12 PIECES

Number of Pieces	Weight each	Order Code SEN-572	Price/1 TB
12	1.25kg	-9990K	1564.00

8-Piece Set Contents (mm):

-  6.3 stubby, 6.3 x 100 and 8.0 x 200.
-  3.0 x 75 and 4.0 x 100.
-  No.2 stubby, No.1 x 75. and No.2 x 100.

ACRYLIC GRIP HANDLES

8 PIECES



Number of Pieces	Weight each	Order Code SEN-572	Price/1 TB
8	580g	-9890K	720.00

Dual Grip Screwdriver Sets

Comfort rubber grip handles with chrome vanadium, chrome-plated blades and magnetic tips.



5-Piece Set Contents (mm):

-  No.2 x 100, No.3 x 150.
-  3 x 75, 5 x 150.
-  8 x 200.

RUBBER GRIP HANDLES

5 PIECES

Number of Pieces	Weight each	Order Code SEN-572	Price/1 TB
5	600g	-9050K	367.00

10-Piece Set Contents (mm):





-  No.2 x 100, No.3 x 150, No.2 stubby.
-  No.2 x 100, No.3 x 150.
-  3 x 75, 5 x 150, 5 x 250.
-  8 x 200, 6 stubby.

RUBBER GRIP HANDLES

10 PIECES

Number of Pieces	Weight each	Order Code SEN-572	Price/1 TB
10	995g	-9100K	770.00

15-Piece Set Contents (mm):

-  No.1 x 75, No.2 x 100, No.3 x 150, No.2 x stubby.
-  No.1 x 75, No.2 x 100, No.3 x 150.
-  3 x 75, 5 x 150, 5 x 200, 5 x 250.
-  6 x 150, 8 x 200, 9.5 x 300, 6 x stubby.

RUBBER GRIP HANDLES

15 PIECES

Number of Pieces	Weight each	Order Code SEN-572	Price/1 TB
15	1.63kg	-9150K	1236.00

HAND TOOLS

GROUP 572 SCREWDRIVERS

KENNEDY Insulated Interchangeable Screwdriver Set

Ergonomic insulated full size handle, swivel cap and eight interchangeable drivers supplied in a compact protective pouch with belt loop. 2-in-1 design, use the detachable swivel cap for fast (low torque) driving, or use the full size detachable ergonomic handle for higher torque fastening. Safe up to 1000V AC/1500V DC.



**10
PIECES**

10 Piece Set Contents (mm):

 0.4 x 2.5 x 100, 0.5 x 3.0 x 100, 0.8 x 4.0 x 100, 1.0 x 5.5 x 100 and 1.2 x 6.5 x 100.

 No.0 x 100, No.1 x 100 and No.2 x 100.



Number of Pieces	Weight each	Order Code KEN-572	Price/1 TB
10	365g	-5870K	2138.00

1000V Dual Grip VDE Screwdrivers

A fully insulated screwdriver VDE tested up to 1000V. Professional high grip handles, magnetic tips, chrome vanadium steel blades.



Crosspoint

Crosspoint screws virtually eliminate the screwdriver slippage if the correct size is used. The No.2 driver is suitable for most applications.



Parallel Tip

Slotted head screws are the most commonly used screw. To safely drive these screws, the tip of the screwdriver should be of the same width as the slot in the screw head and fill it as well, to minimise slipping and deforming the screw head.



Tip Size	Blade Length	Weight each	Order Code KEN-572	Price/1 TB
No.0	60mm	20g	-7900K	342.00
No.1	80mm	60g	-7910K	399.00
No.2	100mm	90g	-7920K	476.00

Tip Size	Blade Length	Weight each	Order Code KEN-572	Price/1 TB
2.5mm	75mm	20g	-7940K	342.00
4.0mm	100mm	60g	-7950K	399.00
5.5mm	125mm	75g	-7960K	510.00
6.5mm	150mm	110g	-7970K	554.00

Set Contents (mm):

 2.5 x 75, 4.0 x 100, 5.5 x 125, 6.5 x 150.

 No.0 x 60, No.1 x 80, No.2 x 100.

**7
PIECES**

Number of Pieces	Weight each	Order Code KEN-572	Price/1 TB
7	715g	-8000K	1684.00



Electrician's VDE Square Section Handle Screwdrivers

Volt-tested to ensure safety on or near electrical equipment up to 1000V AC or 1500V DC. Insulated blades with magnetic tips. Conform with DIN 7438 and DIN EN 60900.



Crosspoint

Crosspoint screws virtually eliminate the screwdriver slippage if the correct size is used. The No.2 driver is suitable for most applications.



Parallel Tip

Slotted head screws are the most commonly used screw. The tip of the screwdriver should be of the same width as the slot in the screw head and fill it as well, to minimise slipping.



Tip Size	Blade Length	Weight each	Order Code KEN-572	Price/1 TB
No.0	75mm	27g	-5820K	106.00
No.1	100mm	50g	-5830K	126.00
No.2	100mm	80g	-5840K	146.00

Tip Size	Blade Length	Weight each	Order Code KEN-572	Price/1 TB
2.5mm	85mm	30g	-5760K	120.00
4.0mm	100mm	45g	-5780K	125.00
5.5mm	125mm	80g	-5790K	175.00
6.5mm	150mm	100g	-5800K	183.00

Set Contents (mm):
Supplied in clear plastic wallet.

 2.5 x 85, 4.0 x 100, 5.5 x 125, 6.5 x 150.

 No.0 x 75, No.1 x 100, No.2 x 100.

**7
PIECES**

Number of Pieces	Weight each	Order Code KEN-572	Price/1 TB
7	495g	-5900K	1013.00





KENNEDY *Spiral Ratchet Screwdrivers*
QUALITY INDUSTRIAL TOOLING

Polished chrome plated body. 3-way ratchet. Quick release chuck, with swivel grip. Lacquered wooden handles. Chrome vanadium steel bits. Supplied with No.1 and No.2 crosspoint and 5.5mm and 7.0mm flared screwdriver bits.



Overall length: closed 300mm
extended 480mm (inc. bit)



Size	Order Code KEN-572	Price/1 TB
430mm	-8160K	821.00

Bits

Bits Sizes	Order Code KEN-572	Price/1 TB
5.5mm Flat	-8820K	47.00
7.0mm Flat	-8840K	47.00
No.1 Crosspoint	-8860K	55.00
No.2 Crosspoint	-8880K	55.00



Precision Jeweller's Screwdriver Set

12-in-1 Set

This handy jeweller's screwdriver set has six interchangeable 30 x 3.6mm hex. Double ended bits.

Contents: 1.00, 1.50, 2.00, 2.50, 3.00, 3.50, T20, PH000, PH00, PH0, PH1, PZ0

Handle size:
90 x 7.7mm diameter.

**7
PIECES**

Number of Pieces	Order Code KEN-572	Price/1 TB
7	-9000K	466.00



KENNEDY PROFESSIONAL Aluminium-Bronze Spark-Resistant Screwdrivers

Spark-resistant tools are used to eliminate the chances of accidental fires or explosions in potentially combustible or explosive environments. They resist the sparks that a standard tool could potentially create when striking hard surfaces. The use of spark resistant tools is essential in many industrial applications such as petroleum and chemical manufacturing, spray booth operations, the marine industry, the mining industry, the paper industries, or any location where flammable vapours or combustible residues are present. Aluminium-bronze spark-resistant safety tools are manufactured to 25HRC and offer a breaking strain of 75 - 85kgf/mm².



Spark-resistant tools must be maintained with special care. Frequent cleaning/re-dressing to remove ferrous particles or contaminants, which may impair the spark resistant properties, is essential.

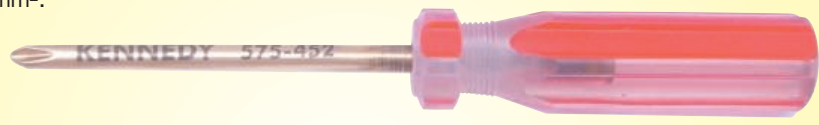

Tip Size	Blade Length	Weight each	Order Code KEN-575	Price/1 TB
6.0mm	100	60g	-4020K	1066.00
6.0mm	150	80g	-4040K	1492.00
7.5mm	200	120g	-4060K	1811.00
9.0mm	250	180g	-4080K	2450.00
9.0mm	300	200g	-4100K	2982.00

Tip Size	Blade Length	Weight each	Order Code KEN-575	Price/1 TB
No.1	75	55g	-4520K	876.00
No.2	100	60g	-4540K	1082.00
No.3	150	100g	-4560K	1545.00
No.4	200	120g	-4580K	1854.00



Precision Screwdrivers

Nickel chrome molybdenum steel blades, hardened and tempered in choice of crosspoint and parallel tips. Chrome plated, with swivel tops which resist oil and acid. Supplied in plastic cases. Ideal for jewellers and watchmakers.

Parallel



Type	Tip Size (mm)	Weight each	Order Code KEN-572	Price/1 TB
PARALLEL	1.0	5g	-9100K	36.00
	1.2	10g	-9110K	36.00
	1.4	10g	-9120K	36.00
	1.8	10g	-9130K	36.00
	2.0	10g	-9140K	41.00
	2.4	15g	-9150K	41.00
PARALLEL	3.0	20g	-9160K	51.00
	3.8	30g	-9170K	51.00

Crosspoint



Type	Tip Size (mm)	Weight each	Order Code KEN-572	Price/1 TB
CROSSPOINT	PH0.4	5g	-9200K	51.00
	PH0.3	10g	-9210K	51.00
	PH0.2	10g	-9220K	51.00
	PH0	15g	-9230K	51.00
	PH1.1	30g	-9250K	51.00

HAND TOOLS

PRODUCTS ARE ONLY AVAILABLE VIA YOUR DISTRIBUTOR

GROUP 572 SCREWDRIVERS

KENNEDY Jeweller's & Watchmaker's Tool Sets
QUALITY INDUSTRIAL TOOLING Carbon Steel & Alloy Steel Blades



A quality range of precision screwdrivers. Combination tool and driver sets have carbon steel blades (tweezers are stainless steel). Driver only sets have nickel chrome molybdenum alloy steel blades. All with attractive chromed handles.

11-Piece Set

CARBON STEEL BLADES

Contents:

- 1.0, 1.2, 1.4, 1.8, 2.4 and 3.0mm.

- PHO-2, PHO and PH1
Fine point awl and tweezers.

**11
PIECES**



Number of Pieces	Weight each	Order Code	Price/1 TB
11	220g	KEN-572	442.00

6-Piece Parallel Set

ALLOY STEEL BLADES

Contents:

- 1.0, 1.4, 2.0, 2.4, 3.0 and 3.8mm.



**6
PIECES**

Number of Pieces	Weight each	Order Code	Price/1 TB
6	155g	KEN-572	187.00

5-Piece Hexagon Key Driver Set

ALLOY STEEL BLADES

Contents:

- 0.9, 1.3, 1.5, 2.0 and 2.5mm.



**5
PIECES**

Number of Pieces	Weight each	Order Code	Price/1 TB
5	130g	KEN-572	251.00

11-Piece Set

CARBON STEEL BLADES

Contents:

- 1.0, 1.2, 1.4, 1.8, 2.4 and 3.0mm.

- PHO-4, PHO-3, PHO-2, PHO and PH1.

**11
PIECES**



Number of Pieces	Weight each	Order Code	Price/1 TB
11	210g	KEN-572	442.00

6-Piece Crosspoint Set

ALLOY STEEL BLADES

Contents:

- PHO-4, PHO-3, PHO-2, PHO, PH1-2 and PH1.

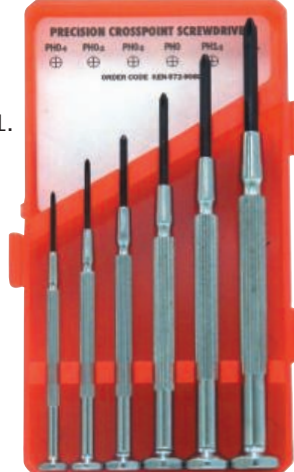

**6
PIECES**

Number of Pieces	Weight each	Order Code	Price/1 TB
6	140g	KEN-572	187.00



Group 316
See Page **253**

11-Piece Set

CARBON STEEL BLADES

Contents:

- 1.0, 1.2, 1.4, 1.8, 2.4 and 3.0mm.

- PHO-2, PHO and PH1, fine point, awl and magnet.

**11
PIECES**



Number of Pieces	Weight each	Order Code	Price/1 TB
11	225g	KEN-572	442.00

6-Piece Parallel & Crosspoint Set

ALLOY STEEL BLADES

Contents:

- 1.4, 2.0, 2.4, and 3.0mm.

- PHO and PH1.

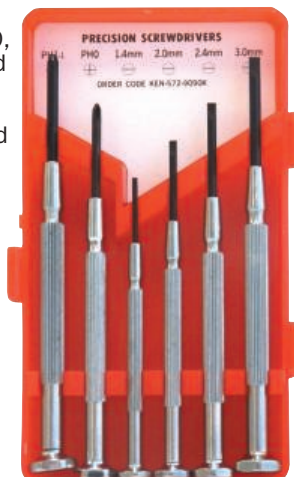

**6
PIECES**

Number of Pieces	Weight each	Order Code	Price/1 TB
6	155g	KEN-572	187.00

5-Piece Nut Driver Set

ALLOY STEEL BLADES

Contents:

- 3.0, 3.5, 4.0, 4.5 and 5.0mm.



**5
PIECES**

Number of Pieces	Weight each	Order Code	Price/1 TB
5	170g	KEN-572	318.00

HAND TOOLS

KENNEDY PROFESSIONAL Pro-Torg Precision Screwdrivers

Expert quality, hardened and tempered chrome alloy steel blades with black magnetic tips. Fitted with a unique dual grip handle with revolving top designed for added user comfort whilst allowing more torque to be applied.



Crosspoint

Crosspoint screws virtually eliminate the screwdriver slippage if the correct size is used. The No.2 driver is suitable for most applications.



Tip Size	Blade Length	Weight each	Order Code KEN-572	Price/1 TB
No.0-3	40	15g	-4430K	154.00
No.0-2	40	15g	-4390K	154.00
No.0-2	75	15g	-4420K	154.00
No.0-0	40	15g	-4380K	154.00
No.0	75	15g	-4400K	154.00
No.1	100	20g	-4410K	154.00

Parallel Tip

Slotted head screws are the most commonly used screw. To safely drive these screws, the tip of the screwdriver should be of the same width as the slot in the screw head.



Tip Size	Blade Length	Weight each	Order Code KEN-572	Price/1 TB
1.4mm	40	15g	-4300K	134.00
2.0mm	40	15g	-4310K	134.00
2.4mm	40	15g	-4320K	134.00
3.0mm	40	15g	-4330K	134.00
2.4mm	75	15g	-4340K	134.00
3.0mm	75	20g	-4350K	134.00
4.0mm	100	25g	-4360K	154.00

TX

TX head screws are used predominantly for engineering and automotive applications. The design of the screw allows high torque levels to be applied without the driver slipping.



Tip Size	Blade Length	Weight each	Order Code KEN-572	Price/1 TB
T6	40	15g	-6470K	115.00
T8	40	15g	-6472K	115.00
T9	50	15g	-6474K	115.00
T10	50	15g	-6476K	115.00
T15	60	20g	-6478K	115.00
T20	60	20g	-6480K	115.00

Set

Alloy steel blades, black oxidised tips, dual material handles for improved grip, revolving end caps. Supplied in leatherette zip around case.

Set Contents:

- TX T6 x 40, T8 x 40, T9 x 50, T10 x 50, T15 x 60 and T20 x 60.

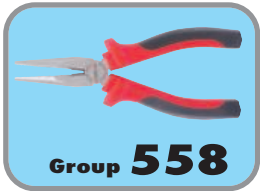

Number of Pieces	Weight each	Order Code KEN-572	Price/1 TB
6	170g	-6490K	800.00

6
PIECES

Set

Complete with protective zip case.

Set Contents:

- PARALLEL 1.4 x 40, 2.0 x 40, 2.4 x 75, 3.0 x 75 and 4.0 x 100mm.

- CROSS POINT PH0-3 x 40, PH0-2 x 75, PH-0 x 75 and PH1 x 100mm.



Number of Pieces	Weight each	Order Code KEN-572	Price/1 TB
9	265g	-4470K	1200.00

9
PIECES

Set

All screwdrivers have 40mm blade length. Complete with protective zip case.

Set Contents:

- PARALLEL 1.4, 2.0, 2.4 and 3.0mm.

- CROSS POINT PH0-3, PH0-2 and PH-0.



Number of Pieces	Weight each	Order Code KEN-572	Price/1 TB
7	165g	-4450K	886.00

7
PIECES



HAND TOOLS

GROUP 573 SCREWDRIVER BITS

KENNEDY Heavy Duty Magnetic Driver
QUALITY INDUSTRIAL TOOLING

Square section mechanic's pattern handle. Suitable for use with 1/4" hexagon driver bits etc. Hexagonal blade also allows the application of a spanner for high torque.

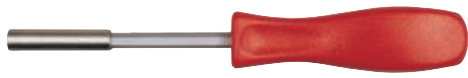

Overall Length	Weight Per 5	Order Code KEN-573	Price/1 TB
200mm (8")	750g	-7070K	402.00

1/4" Hex Bit Ratchet

Included in the Kennedy 39 piece Socket and Screwdriver Bit Set (KEN-582-7910K)

NEW



Size	Order Code KEN-573	Price/1 TB
1/4"	-9050K	750.00

6-in-1 Handles

Contoured grip plastic grip handle for improved comfort, control and higher torque. In-handle storage of up to six bits. Magnetic bit retention.

EXTENDED RANGE

Ratchet

Switchable forward, reverse and fixed positive industrial quality ratchet action. Bright finish chrome vanadium blade.



Fixed

Chrome vanadium steel blade with plastic sheaving to prevent damage to fragile components.



Supplied with 25mm long 6mm (1/4") hex bits:



Crosspoint
No.1 and 2.



PZ
No.1 and 2.



Flat:
5 and 6mm.

Handle Type	Overall Length	Weight each	Order Code KEN-573	Price/1 TB
Ratchet	200mm (8")	175g	-7040K	524.00
Fixed	200mm (8")	205g	-7060K	603.00

Reversible Blade Screwdriver

145mm long reversible hexagon blade with 6mm flat point and No.2 crosspoint ends. Cabinet handle style.

Overall length: 155mm.



Overall Length	Weight	Order Code KEN-573	Price/1 TB
155mm/6"	55g	-7400K	366.00

Magnetic Screwdriver Bit Holder

Chrome vanadium steel blade with moulded dual grip handle for improved user comfort allowing more torque to be applied. Fixed blade with a quick release magnetic chuck.

Overall length: 185mm.
Blade length: 80mm.



Overall Length	Order Code KEN-573	Price/1 TB
200mm (8")	-7420K	541.00

KENNEDY PROFESSIONAL

Magnetic Screwdriver Bit Set

11 piece 1/4" hexagon bits. Chrome vanadium steel blade with moulded dual grip handle designed for improved user comfort allowing more torque to be applied. Switchable forward, reverse and fixed positive industrial quality ratchet action. Bright finish chrome vanadium blade.



11 PIECES

Contents

25mm Driver Bits:

- ⊕ Crosspoint: No.1, 2 and 3.
- ⊗ PZ: No.1, 2 and 3.
- ⊖ Flat: 3, 4, 5 and 6mm.



Magnetic bit retention



Bit storage in handle

Product Number	Overall Length	Order Code KEN-573	Price/1 TB
DBH100	200mm (8")	-7050K	684.00

Torsion Bits 1/4" Hex Drive

Manufactured from chrome vanadium for greater impact resistance and a longer lasting bit. Available as crosspoint, slotted, pozidriv, TX and hexagon. Colour coded to aid speedier recognition.



Crosspoint



25mm



50mm

Point Size	Overall Length	Order Code KEN-573	Price/1 TB
No.1	25	-8220K	55.00
No.2	25	-8222K	55.00
No.3	25	-8224K	55.00
No.2	50	-8226K	75.00
No.3	50	-8228K	75.00



NEW

25mm



Point Size	Overall Length	Order Code KEN-573	Price/1 TB
0.8 x 4.0	25	-8240K	55.00
0.6 x 4.5	25	-8242K	55.00
0.6 x 4.5	25	-8244K	55.00
0.6 x 4.5	25	-8246K	55.00

PZ Torsion



25mm



50mm

Point Size	Overall Length	Order Code KEN-573	Price/1 TB
No.1	25	-8250K	55.00
No.2	25	-8252K	55.00
No.3	25	-8254K	55.00
No.1	50	-8256K	75.00
No.2	50	-8258K	75.00
No.3	50	-8260K	75.00

Square Torsion



NEW

25mm



Point Size	Overall Length	Order Code KEN-573	Price/1 TB
No.1	25	-8262K	55.00
No.2	25	-8264K	55.00
No.3	25	-8266K	55.00

TX Torsion



NEW

25mm



Point Size	Overall Length	Order Code KEN-573	Price/1 TB
TX10	25	-8270K	65.00
TX15	25	-8272K	65.00
TX20	25	-8274K	65.00
TX25	25	-8276K	65.00
TX30	25	-8278K	65.00
TX40	25	-8280K	65.00

Hexagon



NEW

25mm



Point Size	Overall Length	Order Code KEN-573	Price/1 TB
No.1	25	-8290K	55.00
No.2	25	-8292K	55.00
No.3	25	-8294K	55.00
No.2	50	-8296K	55.00
No.3	50	-8298K	55.00

60mm Torsion Quick Magnetic Bit Holder

For use with the Kennedy Torsion Bit Set (KEN-573-6460K)

NEW



Overall Length	Order Code KEN-573	Price/1 TB
60mm	-8720K	550.00

HAND TOOLS



KENNEDY Screwdriver Bits
QUALITY INDUSTRIAL TOOLING

All Kennedy screwdriver bits have a hardness of 58 - 62HRC. High alloy chrome molybdenum steel for use on hand and power tools.

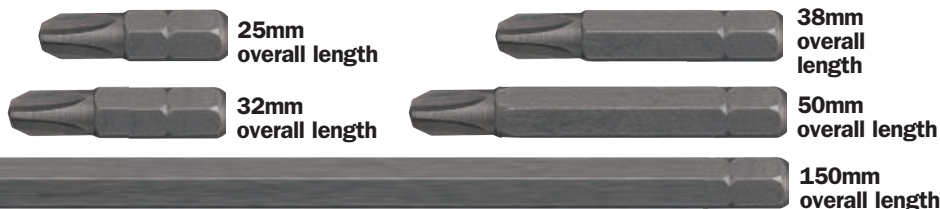

1/4" Hex Drive Bits

Flat



Tip Size	Overall Length	Weight each	Order Code KEN-573	Price/1 TB
3.0	25	5g	-1360K	42.00
3.0	38	5g	-1760K	50.00
3.5	25	5g	-1370K	42.00
3.5	38	5g	-1770K	50.00
4.0	25	5g	-1380K	41.00
4.0	38	5g	-1780K	50.00
4.5	25	5g	-1390K	41.00
4.5	38	5g	-1790K	38.00
5.0	25	5g	-1400K	42.00
5.0	38	5g	-1800K	50.00
5.0	150	30g	-1170K	176.00
5.5	25	5g	-1410K	42.00
5.5	38	10g	-1810K	38.00
5.5	150	30g	-1172K	176.00
6.0	25	5g	-1420K	42.00
6.0	38	10g	-1820K	50.00
6.0	150	30g	-1174K	176.00
6.5	25	5g	-1430K	42.00
6.5	38	10g	-1830K	38.00
8.0	25	5g	-1460K	42.00
8.0	38	10g	-1860K	50.00
10.0	25	10g	-1500K	53.00

PZ



Point Size	Overall Length	Weight each	Order Code KEN-573	Price/1 TB
No.0	25	5g	-1100K	56.00
No.1	25	5g	-1110K	42.00
No.1	50	10g	-1710K	50.00
No.1	150	30g	-1160K	176.00
No.2	25	5g	-1120K	42.00
No.2	50	10g	-1720K	50.00
No.2	150	30g	-1162K	176.00
No.3	25	5g	-1130K	42.00
No.3	50	10g	-1730K	50.00
No.3	150	30g	-1164K	176.00
No.4	25	5g	-1140K	56.00

Crosspoint



Point Size	Overall Length	Weight each	Order Code KEN-573	Price/1 TB
No.0	25	5g	-1000K	42.00
No.1	25	5g	-1010K	42.00
No.1	50	10g	-1610K	50.00
No.1	150	30g	-1150K	176.00
No.2	25	5g	-1020K	42.00
No.2R	25	5g	-1022K	57.00
No.2	50	10g	-1620K	50.00
No.2	150	30g	-1152K	176.00
No.3	25	5g	-1030K	42.00
No.3	50	10g	-1630K	50.00
No.3	150	30g	-1154K	176.00
No.4	25	5g	-1040K	56.00
No.4	32	30g	-1156K	176.00

1/4" Hexagon Drive Cup Hook Driver Bit



A hollowed out 'Y' shaped driver bit designed for the driving in of cup hooks.
Overall length: 25mm.

Overall Length	Order Code KEN-573	Price/1 TB
25mm	-7500K	111.00

1/4" Hex Contractor Packs

The most popular style driver bits, multi-packed for economy. Supplied in plastic pocket cases that are ideal for the industrial user.

Insert Bits: plain shank for use with bit adaptors etc.
Direct Bits: ball recessed for use in power tools.

No.2 PZ



Bit Style	Length (mm)	Pack Qty	Weight/Pack	Order Code KEN-573	Price/1 TB
Insert	25	10	60g	-1125K	334.00
Insert	50	5	60g	-1725K	204.00
Direct	53	5	60g	-2125K	176.00

No.2 Crosspoint



Bit Style	Length (mm)	Pack Qty	Weight/Pack	Order Code KEN-573	Price/1 TB
Insert	25	10	60g	-1025K	335.00
Insert	50	5	60g	-1625K	346.00

TX20



Bit Style	Length (mm)	Pack Qty	Weight/Pack	Order Code KEN-573	Price/1 TB
Insert	25	10	60g	-3705K	384.00



TX



Tip Size	Overall Length	Weight each	Order Code KEN-573	Price/1 TB
TX5	25	5g	-3558K	56.00
TX6	25	5g	-3560K	50.00
TX7	25	5g	-3570K	50.00
TX8	25	5g	-3580K	50.00
TX9	25	5g	-3590K	50.00
TX10	25	5g	-3600K	50.00
TX15	25	5g	-3650K	50.00
TX20	25	5g	-3700K	50.00
TX25	25	5g	-3750K	50.00
TX27	25	5g	-3770K	50.00
TX30	25	5g	-3800K	50.00
TX40	25	5g	-3900K	50.00
TX45	25	5g	-3910K	56.00
TX50	25	5g	-3920K	56.00

Tamperproof TXS



For repair and servicing on electronic, electrical and mechanical equipment.

Tip Size	Overall Length	Weight each	Order Code KEN-573	Price/1 TB
TX6	25	4g	-4100K	103.00
TX7	25	4g	-4110K	103.00
TX8	25	4g	-4120K	103.00
TX9	25	4g	-4130K	106.00
TX10	25	4g	-4140K	103.00
TX15	25	4g	-4150K	103.00
TX20	25	4g	-4160K	103.00
TX25	25	4g	-4170K	103.00
TX27	25	5g	-4180K	103.00
TX30	25	5g	-4190K	103.00
TX40	25	5g	-4200K	103.00

Hexagon



Point Size	Overall Length	Weight each	Order Code KEN-573	Price/1 TB
3/32"	25	5g	-3350K	42.00
1/8"	25	5g	-3360K	42.00
5/32"	25	5g	-3370K	42.00
3/16"	25	5g	-3380K	42.00
1/4"	25	5g	-3390K	42.00
7/32"	25	5g	-3400K	42.00
5/16"	25	5g	-3410K	42.00
1.5	25	5g	-3430K	66.00
2.0	25	5g	-3440K	66.00
2.5	25	5g	-3450K	42.00
3.0	25	5g	-3460K	42.00
4.0	25	5g	-3470K	42.00
5.0	25	5g	-3480K	42.00
5.5	25	5g	-3485K	78.00
6.0	25	5g	-3490K	42.00
7.0	25	5g	-3500K	42.00
8.0	25	5g	-3510K	42.00
10.0	25	5g	-3530K	66.00

Ball Point Hexagon



Hex Size	Overall Length	Weight each	Order Code KEN-573	Price/1 TB
1.5	25	5g	-3540K	28.00
2.0	25	5g	-3542K	28.00
2.5	25	5g	-3544K	28.00
3.0	25	5g	-3546K	28.00
4.0	25	5g	-3548K	28.00
5.0	25	5g	-3550K	28.00
6.0	25	5g	-3552K	28.00

Tamperproof Hex



Hex Size	Overall Length	Weight each	Order Code KEN-573	Price/1 TB
1.5	25	5g	-8680K	125.00
2.0	25	5g	-8682K	125.00
2.5	25	5g	-8684K	125.00
3.0	25	5g	-8686K	125.00
4.0	25	5g	-8688K	125.00
5.0	25	5g	-8690K	125.00
5.5	25	5g	-8692K	125.00
6.0	25	5g	-8694K	125.00
7.0	25	5g	-8696K	125.00
8.0	25	5g	-8698K	125.00

GROUP 573 SCREWDRIVER BITS

KENNEDY 1/4" Hex Bits
QUALITY INDUSTRIAL TOOLING

ACR® Ribbed Cosspoint System
Anti-Cam-out Recess. Keeps the bit securely mated to the screw during removal, reducing damage to the recess and surrounding areas. This ensures secure removal every time with lower costs, more productivity and less drill outs. Also allows off-angle driving and acts as torque limit on installation. Preferred system for aerospace and military industries.

Phillips ACR®

Tip Size	Overall Length	Weight each	Order Code KEN-573	Price/1 TB
No.1	25	5g	-8648K	50.00
No.2	25	5g	-8650K	50.00
No.3	25	5g	-8652K	50.00

ACR® II Ribbed Cosspoint System
Anti-Cam-out Recess. Designed to meet the ever-challenging needs of faster assembly processes that can cause bit cam-out, creating component surface damage and scrapage. Allows off-angle driving in difficult positions and reduces end-load pressure, reducing operator fatigue. Improves assembly times, reducing defects and rework, also makes disassembly easier for more effective service and maintenance. Preferred system for automotive, electronics and general assembly industries.

Phillips ACR® II

Tip Size	Overall Length	Weight each	Order Code KEN-573	Price/1 TB
No.1	25	5g	-8640K	50.00
No.2R*	25	5g	-8642K	50.00
No.2	25	5g	-8644K	50.00
No.3	25	5g	-8646K	50.00

* R = Reduced neck diameter

Pozi ACR® II

Tip Size	Overall Length	Weight each	Order Code KEN-573	Price/1 TB
No.1	25	5g	-8630K	50.00
No.2	25	5g	-8632K	50.00
No.3	25	5g	-8634K	50.00

ACR® is a trademark of the Phillips Screw Co.



Tri-Wing

Tip Size	Overall Length	Weight each	Order Code KEN-573	Price/1 TB
No.0	25	4g	-2900K	38.00
No.1	25	4g	-2910K	38.00
No.2	25	4g	-2920K	42.00
No.3	25	4g	-2930K	42.00
No.4	25	5g	-2940K	42.00
No.5	25	5g	-2950K	42.00
No.6	25	6g	-2960K	42.00
No.7	25	7g	-2970K	56.00
No.8	25	8g	-2980K	56.00

SIT®

Tip Size	Overall Length	Weight each	Order Code KEN-573	Price/1 TB
No.10	25	5g	-8620K	95.00
No.20	25	5g	-8622K	95.00
No.25	25	5g	-8624K	95.00
No.30	25	5g	-8626K	95.00
No.40	25	5g	-8628K	95.00

Square

Tip Size	Overall Length	Weight each	Order Code KEN-573	Price/1 TB
0	25	5g	-8510K	50.00
1	25	5g	-8512K	50.00
2	25	5g	-8514K	50.00
3	25	5g	-8516K	50.00
4	25	5g	-8518K	50.00

Spline

Tip Size	Overall Length	Weight each	Order Code KEN-573	Price/1 TB
4	25	5g	-8530K	88.00
5	25	5g	-8532K	88.00
6	25	5g	-8534K	88.00
8	25	5g	-8536K	88.00
10	25	5g	-8538K	88.00

Spanner

Tip Size	Overall Length	Weight each	Order Code KEN-573	Price/1 TB
No.4	25	5g	-8660K	125.00
No.6	25	5g	-8662K	125.00
No.8	25	5g	-8664K	125.00
No.10	25	5g	-8666K	125.00
No.12	25	5g	-8668K	125.00

Torq® Sets

Tip Size	Overall Length	Weight each	Order Code KEN-573	Price/1 TB
No.4	25	5g	-8600K	100.00
No.5	25	5g	-8602K	100.00
No.6	25	5g	-8604K	100.00
No.8	25	5g	-8606K	100.00
No.10	25	5g	-8608K	100.00
1/4"	25	5g	-8610K	100.00

Clutch

Tip Size	Overall Length	Weight each	Order Code KEN-573	Price/1 TB
5/32"	25	5g	-8580K	88.00
3/16"	25	5g	-8582K	88.00
1/4"	25	5g	-8584K	88.00

5/16" Hex Bits

Point Size	Overall Length	Weight each	Order Code KEN-573	Price/1 TB
No.1	32mm	5g	-2410K	98.00
No.2	32mm	5g	-2420K	54.00
No.3	32mm	10g	-2430K	54.00
No.4	38mm	10g	-2440K	54.00

PZ

Point Size	Overall Length	Weight each	Order Code KEN-573	Price/1 TB
No.1	32mm	10g	-2510K	54.00
No.2	32mm	10g	-2520K	54.00
No.3	32mm	10g	-2530K	54.00
No.4	38mm	10g	-2540K	54.00

Flat

Point Size	Overall Length	Weight each	Order Code KEN-573	Price/1 TB
6.0	41mm	15g	-2720K	54.00
8.0	41mm	15g	-2780K	79.00
10.0	41mm	20g	-2800K	84.00
12.0	41mm	20g	-2820K	85.00
14.0	41mm	25g	-2880K	85.00

TX

Point Size	Overall Length	Weight each	Order Code KEN-573	Price/1 TB
TX25	35mm	10g	-4250K	59.00
TX30	35mm	10g	-4300K	113.00
TX40	35mm	15g	-4400K	113.00
TX45	35mm	15g	-4450K	113.00
TX50	35mm	15g	-5500K	113.00
TX55	35mm	20g	-5550K	113.00

Double-Ended 1/4" Hex Bits

All with overall length 60mm (2 3/8").

Crosspoint x Slotted

Tip Width x Size	Weight each	Order Code KEN-573	Price/1 TB
4.5mm x No.1	10g	-5610K	54.00
5.5mm x No.2	10g	-5620K	71.00
7.0mm x No.3	10g	-5630K	71.00

Slotted x PZ

Tip Width x Size	Weight each	Order Code KEN-573	Price/1 TB
4.5mm x No.1	10g	-5710K	71.00
5.5mm x No.2	10g	-5720K	76.00
7.0mm x No.3	10g	-5730K	76.00

Crosspoint

Tip Width x Size	Weight each	Order Code KEN-573	Price/1 TB
No.1 x No.2	10g	-5810K	76.00
No.2 x No.3	10g	-5820K	76.00
No.2 x No.2	10g	-5920K	76.00

PZ

Tip Width x Size	Weight each	Order Code KEN-573	Price/1 TB
No.1 x No.2	15g	-5850K	76.00
No.2 x No.3	15g	-5860K	76.00
No.2 x No.2	15g	-5950K	76.00

10mm Hex Drive Bits

TX

Tip Size	Overall Length	Weight each	Order Code KEN-573	Price/1 TB
TX20	30	13g	-8750K	139.00
	75	43g	-8770K	163.00
TX25	30	13g	-8752K	139.00
	75	43g	-8772K	163.00
TX30	30	13g	-8754K	139.00
	75	43g	-8774K	163.00
TX40	30	14g	-8756K	139.00
	75	44g	-8776K	163.00
TX45	30	15g	-8758K	139.00
	75	45g	-8778K	163.00
TX50	30	16g	-8760K	139.00
	75	46g	-8780K	163.00
TX55	30	18g	-8762K	146.00
	75	48g	-8782K	183.00

Hexagon

Point Size	Overall Length	Weight each	Order Code KEN-573	Price/1 TB
4	30	12g	-8800K	56.00
5	30	15g	-8802K	56.00
6	30	16g	-8804K	56.00
7	30	15g	-8806K	56.00
8	30	16g	-8808K	56.00
10	30	19g	-8810K	56.00
12	30	24g	-8812K	66.00
4	75	42g	-8820K	66.00
5	75	44g	-8822K	66.00
6	75	44g	-8824K	66.00
7	75	45g	-8826K	66.00
8	75	46g	-8828K	66.00
10	75	64g	-8830K	66.00
12	75	67g	-8832K	66.00

Spline

3Tip Size	Overall Length	Weight each	Order Code KEN-573	Price/1 TB
5	30	12g	-8880K	66.00
6	30	13g	-8882K	88.00
8	30	14g	-8884K	88.00
10	30	17g	-8886K	88.00
12	30	18g	-8888K	88.00
5	75	39g	-8900K	88.00
6	75	40g	-8902K	88.00
8	75	42g	-8904K	88.00
10	75	46g	-8906K	99.00
12	75	54g	-8908K	99.00

HAND TOOLS



KENNEDY Titanium Screwdriver Bits
QUALITY INDUSTRIAL TOOLING

Titanium bits improve wear resistance. For use with hand and power tools.

1/4" Hex Bits - Flat

Point Size	Length (mm)	Order Code KEN-573	Price/1 TB
5.0	25	-8042K	62.00
6.0	25	-8044K	62.00

1/4" Hex Bits - Crosspoint

Point Size	Length (mm)	Order Code KEN-573	Price/1 TB
No.1	25	-8010K	62.00
No.2	25	-8012K	62.00
No.2	50	-8052K	91.00
No.2	150	-8032K	195.00
No.3	25	-8014K	62.00

1/4" Hex Bits - PZ

Point Size	Length (mm)	Order Code KEN-573	Price/1 TB
No.1	25	-8020K	62.00
No.1	50	-8060K	91.00
No.2	25	-8022K	62.00
No.2	50	-8062K	91.00
No.2	150	-8030K	195.00
No.3	25	-8024K	62.00
No.3	50	-8064K	91.00

1/4" Hex Bits - Hex

Point Size	Length (mm)	Order Code KEN-573	Price/1 TB
2.5	25	-8102K	62.00
3.0	25	-8104K	62.00
4.0	25	-8106K	62.00
5.0	25	-8108K	62.00
6.0	25	-8110K	66.00
8.0	25	-8112K	66.00

1/4" Hex Bits - TX

Point Size	Length (mm)	Order Code KEN-573	Price/1 TB
TX10	25	-8152K	66.00
TX15	25	-8154K	66.00
TX20	25	-8156K	66.00
TX25	25	-8158K	66.00
TX30	25	-8160K	66.00
TX40	25	-8162K	70.00

1/4" Direct Drive Bits - Crosspoint

Point Size	Length (mm)	Order Code KEN-573	Price/1 TB
No.2	50	-8072K	91.00

1/4" Direct Drive Bits - PZ

Point Size	Length (mm)	Order Code KEN-573	Price/1 TB
No.1	50	-8080K	91.00
No.2	50	-8082K	91.00

1/4" Powerbit - PZ

Point Size	Length (mm)	Order Code KEN-573	Price/1 TB
No.2	70	-8092K	137.00
No.2	90	-8094K	225.00

5/16" Hex Bits - Crosspoint

Point Size	Length (mm)	Order Code KEN-573	Price/1 TB
No.3	30	-8204K	96.00
No.4	30	-8206K	96.00

5/16" Hex Bits - PZ

Point Size	Length (mm)	Order Code KEN-573	Price/1 TB
No.2	30	-8212K	96.00
No.3	30	-8214K	96.00
No.4	40	-8216K	99.00

Desoutter Shank Bits

5/16" hex. with Desoutter style ball locator.

Crosspoint

Point Size	Overall Length	Weight each	Order Code KEN-573	Price/1 TB
No.2	53	15g	-3020K	62.00
No.2	94	15g	-3180K	96.00

PZ

Point Size	Overall Length	Weight each	Order Code KEN-573	Price/1 TB
No.1	53	15g	-3110K	133.00
No.2	53	15g	-3120K	133.00
No.3	53	20g	-3130K	133.00

Desoutter Shank Adaptors

5/16" hexagon shank with Desoutter style ball locator. For use with insert bits.

Socket Hex	Overall Length	Weight each	Order Code KEN-573	Price/1 TB
1/4"	46	35g	-6110K	281.00

Magnetic with Retainer

Socket Hex	Overall Length	Weight each	Order Code KEN-573	Price/1 TB
1/4"	55	35g	-6030K	526.00

Socket Adaptor

1/4" hex. drive.

Square Drive	Length (mm)	Weight each	Order Code KEN-573	Price/1 TB
1/4"	25	30g	-6250K	64.00
1/4"	50	60g	-6260K	56.00

Socket Driver Adaptor

1/4" Hexagon drive magnetic bit adaptor socket.

Square Drive	Length (mm)	Weight each	Order Code KEN-573	Price/1 TB
1/4"	25	16g	-8710K	352.00

Direct Drive Adaptors for Power Tools

1/4" hexagon shank with ball recess. For use with insert bits.

Quick Release with Retainer

Socket Hex	Length (mm)	Weight each	Order Code KEN-573	Price/1 TB
1/4"	60	50g	-6200K	455.00

Magnetic with Retainer

Socket Hex	Length (mm)	Weight each	Order Code KEN-573	Price/1 TB
1/4"	74	70g	-6150K	375.00
5/16"	74	50g	-6170K	375.00

Magnetic

Socket Hex	Length (mm)	Weight each	Order Code KEN-573	Price/1 TB
1/4"	60	20g	-6010K	265.00

1/4" Hex One Touch Adaptor

Included in the Kennedy 39 piece Socket and Screwdriver Bit Set (KEN-582-7910K).

Socket Hex	Order Code KEN-573	Price/1 TB
1/4"	-9060K	499.00

Direct Drive Bits for Power Tools

1/4" Hex with ball recess.

TX

Point Size	Overall Length	Weight each	Order Code KEN-573	Price/1 TB
TX7	38	5g	-3950K	59.00
TX8	38	5g	-3960K	59.00
TX9	38	5g	-4000K	59.00
TX10	38	5g	-4010K	59.00
TX15	38	5g	-4020K	59.00
TX20	38	5g	-4030K	59.00
TX25	38	5g	-4040K	59.00
TX27	38	10g	-4050K	76.00
TX30	38	10g	-4060K	59.00
TX40	38	10g	-4070K	59.00

Flat

Point Size	Overall Length	Weight each	Order Code KEN-573	Price/1 TB
4.0	50	10g	-2180K	71.00
4.0	70	10g	-2320K	43.00
4.0	90	15g	-2340K	56.00
4.5	38	5g	-1520K	47.00
5.0	38	5g	-1530K	47.00
5.0	50	10g	-2200K	71.00
5.0	70	15g	-2322K	43.00
5.0	90	15g	-2342K	56.00
6.0	38	5g	-1550K	47.00
6.0	50	10g	-2220K	71.00
6.0	70	15g	-2324K	43.00
6.0	90	20g	-2344K	65.00
8.0	38	10g	-1560K	41.00
8.0	50	15g	-2260K	89.00
8.0	70	20g	-2326K	50.00
8.0	90	30g	-2346K	76.00
10.0	50	15g	-2300K	98.00
10.0	70	30g	-2328K	65.00
10.0	90	40g	-2348K	71.00

Crosspoint

Point Size	Overall Length	Weight each	Order Code KEN-573	Price/1 TB
No.0	50	5g	-2000K	50.00
No.1	38	7g	-1210K	66.00
No.1	50	8g	-2010K	71.00
No.1	70	8g	-1340K	32.00
No.1	100	7g	-1350K	43.00
No.2	38	8g	-1220K	66.00
No.2	50	10g	-2020K	71.00
No.2	70	8g	-1342K	32.00
No.2	100	7g	-1352K	38.00
No.3	38	8g	-1230K	66.00
No.3	50	10g	-2030K	71.00
No.3	70	8g	-1344K	32.00
No.3	100	7g	-1354K	43.00
No.4	50	10g	-2040K	71.00

PZ

Point Size	Overall Length	Weight each	Order Code KEN-573	Price/1 TB
No.1	38	7g	-1310K	66.00
No.1	50	10g	-2110K	71.00
No.1	70	20g	-2150K	40.00
No.1	90	21g	-2160K	149.00
No.2	38	8g	-1320K	66.00
No.2	50	10g	-2120K	71.00
No.2	70	20g	-2152K	40.00
No.2	90	25g	-2162K	149.00
No.3	38	8g	-1330K	66.00
No.3	50	10g	-2130K	71.00
No.3	70	20g	-2154K	40.00
No.3	90	25g	-2164K	149.00

GROUP 573 SCREWDRIVER BITS

KENNEDY Screwdriver Bit Sets
QUALITY INDUSTRIAL TOOLING

Contents:

- **Hex:** 2, 2.5, 3, 4, 5 and 6mm.
- ⊕ **PZ:** No.1 x2, No.2 x3, No.3 x2.
- ⊗ **TX:** TX10, TX15, TX20 TX25, TX30, TX40.
- ⊕ **Crosspoint:** No.0, No.1 x2, No.2 x3, No.3 x2.
- ⊖ **Flat:** 3, 4, 5, 6 and 6.5mm.
1/4" magnetic drive adaptor.

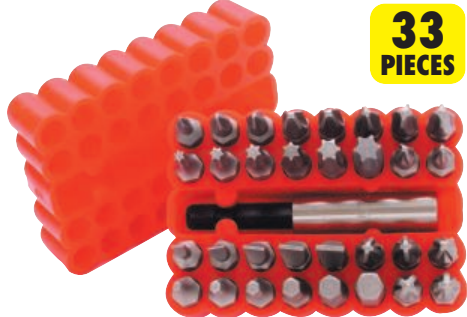

**33
PIECES**

Number of Pieces	Weight each	Order Code KEN-573	Price/1 TB
33	240g	-6480K	726.00

Flat & Crosspoint Bit Set

- ⊖ **Flat:** 3, 4, 5, 6 and 8mm.
- ⊕ **Crosspoint:** No.0, 1, 2 and 3.
All 1/4" hex. x 25mm overall length, complete with quick release 1/4" hexagon bit adaptor.



**10
PIECES**

Number of Pieces	Weight each	Order Code KEN-573	Price/1 TB
10	120g	-6410K	633.00

Tri-Wing Bit Set

- ⊗ **Tri-Wing:** 0, 1, 2, 3, 4, 5, 6, 7 and 8.
- All 1/4" hex. x 25mm. overall length, complete with quick release 1/4" hexagon bit adaptor.



**10
PIECES**

Number of Pieces	Weight each	Order Code KEN-573	Price/1 TB
10	125g	-6550K	732.00

TX Bit Set

- ⊗ T8, 9, 10, 15, 20, 25, 27, 30 and 40.
- All 1/4" hex. x 25mm overall length, complete with quick release 1/4" hexagon bit adaptor.

**10
PIECES**



Number of Pieces	Weight each	Order Code KEN-573	Price/1 TB
10	120g	-6430K	661.00

Tamperproof TXS Bit Set

- ⊗ T8, 9, 10, 15, 20, 25, 27, 30 and 40.
- All 1/4" hex. x 25mm overall length, complete with quick release 1/4" hexagon bit adaptor.

**10
PIECES**



Number of Pieces	Weight each	Order Code KEN-573	Price/1 TB
10	115g	-6440K	655.00

Engineer's Bit Set

All 1/4" hex. x 25mm overall length, complete with magnetic spinner handle, 1/4" hexagon bit adaptor and 1/4" square socket adaptor.

**29
PIECES**

- ⊗ **Hexagon:** 2, 3, 4, 5, 6, 7 and 8mm. 3/32", 1/8", 5/32", 3/16", 1/4", 7/32" and 5/16"
- ⊖ **Flat:** 3, 4, 5, 5.5, 6.5 and 8mm.
- ⊕ **Crosspoint:** No.1, 2 and 3.
- ⊗ **PZ:** No.1, 2 and 3.

Number of Pieces	Weight each	Order Code KEN-573	Price/1 TB
29	500g	-6450K	1011.00



Mechanic's Bit Set

All 1/4" hex. x 25mm overall length, complete with magnetic spinner handle, 1/4" hexagon bit adaptor and 1/4" square socket adaptor.

**29
PIECES**

- ⊗ **TX:** T6, 7, 8, 9, 10, 15, 20, 25, 27, 30 and 40.
- ⊕ **Crosspoint:** No.1, 2 and 3.
- ⊖ **Flat:** 3, 3.5, 4, 4.5, 5, 5.5, 6, 6.5 and 8mm.
- ⊗ **PZ:** No.1, 2 and 3.

Number of Pieces	Weight each	Order Code KEN-573	Price/1 TB
29	480g	-6470K	1131.00

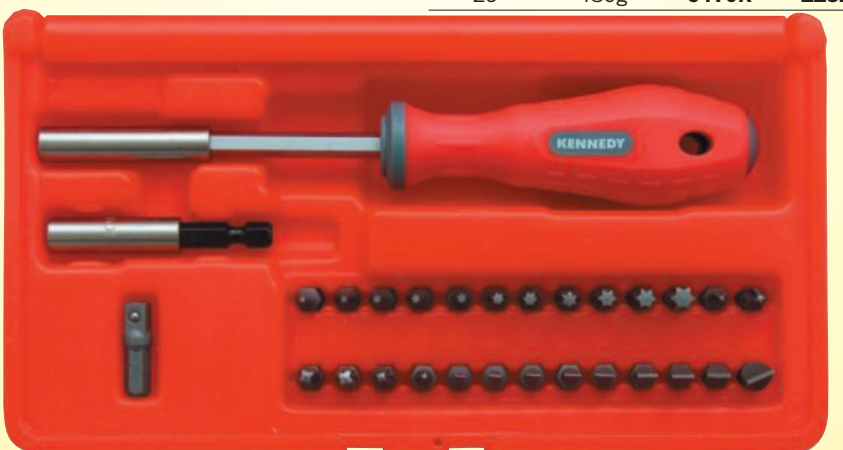

HAND TOOLS

SCREWDRIVER BITS

KENNEDY 10mm AF Hexagon Drive Screwdriver Bit Set
QUALITY INDUSTRIAL TOOLING

TX
Contents: 1/2" Sq. drive x 10mm Hex. bit holder
 TX 10 x 75mm: T20, T25, T30, T40, T45, T50 and T55
 TX 10 x 30mm: T20, T25, T30, T40, T45, T50 and T55
 Torx is a registered trade mark of Camcar/Textron Inc.

**15
PIECES**



Number of Pieces	Case Type	Weight each	Order Code KEN-573	Price/1 TB
15	Moulded	945g	-6340K	1372.00

Ken-Grip Socket & Screwdriver Bit Set

Featuring Ken-Grip patented design sockets that grip up to 95% of a rounded fastener and will not damage fasteners. Manufactured from Chrome Vanadium, they will fit a range of non-metric hexagons and E-Torx drive sizes. The screwdriver bits are manufactured from Chrome Molybdenum.

NEW

Contents:
 Metric sockets: 6mm, 7mm, 8mm, 10mm, 11mm, 12mm, 13mm

Screwdriver bits:

Slotted: 4, 4.5, 6.5, 8

Hexagon: 3, 4, 5, 6

TX: T8, T10, T15, T20, T25, T27, T30, T40.

Torx Temper: TT10, TT15, TT20, TT25, TT27, TT30, TT40.

Crosspoint: No 1, No 2, No 3

Pozidriv: No 1, No 2, No 3.

Accessories: 1/4" x 60mm hex one touch adaptor, L" x 25mm socket adaptor, L" hex bit ratchet.

**39
PIECES**



Number of Pieces	Case Type	Weight each	Order Code KEN-582	Price/1 TB
39	Moulded	450g	-7910K	2750.00

Torsion Bit Set

Manufactured from chrome vanadium, this 15 piece set features torx, crosspoint, pozidriv, slotted and hexagon bits, together with a quick release magnetic bit holder. Bits are colour coded for faster recognition and the set is supplied in a handy sized case.

Contents:

TX: 15, 20, 25

Crosspoint: No 1, No 2, No 3

Pozidriv: No 2

Slotted: 4.0, 5.5, 6.5mm

Hexagon: 3, 4, 5, 6mm

Torsion quick release magnetic bit holder

**15
PIECES**



NEW

Number of Pieces	Case Type	Weight each	Order Code KEN-573	Price/1 TB
15	Moulded	160g	-6460K	999.00

10mm Hexagon Power Bit Set

This Impact Driver Bit Set is suitable for workshop and manufacturing use. Made from chrome molybdenum the range includes Hexagon, TX and Spline bits with 3/8" and 1/2" x 10mm Bit Adaptors that are suitable for hand and power impact drivers.

Contents:
 3/8" and 1/2" Square x 10mm Hexagon Bit Adaptors.

75mm x 10mm Hexagon bits:
 Hexagon: 4, 5, 6, 7, 8, 10 and 12mm.

TX: Tx20, Tx25, Tx30, Tx40, Tx45, Tx50 and Tx55.
 Spline: 5, 6, 8, 10 and 12mm.

30mm x 10mm Hexagon bits:
 Hexagon: 4, 5, 6, 7, 8, 10 and 12mm.
TX: Tx20, Tx25, Tx30, Tx40, Tx45, Tx50 and Tx55.
 Spline: 5, 6, 8, 10 and 12mm.

**40
PIECES**



Number of Pieces	Case Type	Weight each	Order Code KEN-573	Price/1 TB
40	Moulded	1.75kg	-6490K	1634.00

Service Set

1/4" hex. bit holders 1/4" and 3/8" square drive.

1/4" Hex 25mm Long:

TX: T6, 7, 8, 9, 10, 15, 20, 25, 27, 30 and 40.

Flat: 3, 3.5, 4, 4.5, 5, 5.5, 6, 6.5, 8 and 10mm.

Crosspoint: No. 0, 1, 2 and 3.
PZ: No. 1, 2 and 3.

1/4" Hex 38mm Long:

Flat: 3, 3.5, 4, 4.5, 5, 5.5, 6, 6.5 and 8mm.

1/4" Hex 50mm Long Ball Retainer Fitting:

Flat: 4, 5, 6, 8 and 10mm.
PZ: No. 1, 2 and 3.

Crosspoint: No. 0, 1, 2, 3 and 4.

1/4" Hex 50mm Long Plain Hex Shank:

Crosspoint: No. 1, 2 and 3.

PZ: No. 1, 2 and 3.

1/4" Hex 60mm Long Double-Ended:

No.1 **Crosspoint** x 4.5mm **Flat**

No.1 **PZ** x 4.5mm **Flat**

No.2 **Crosspoint** x 5.5mm **Flat**

No.2 **PZ** x 5.5mm **Flat**

No.3 **Crosspoint** x 6.5mm **Flat**

No.3 **PZ** x 6.5mm **Flat**.

**64
PIECES**

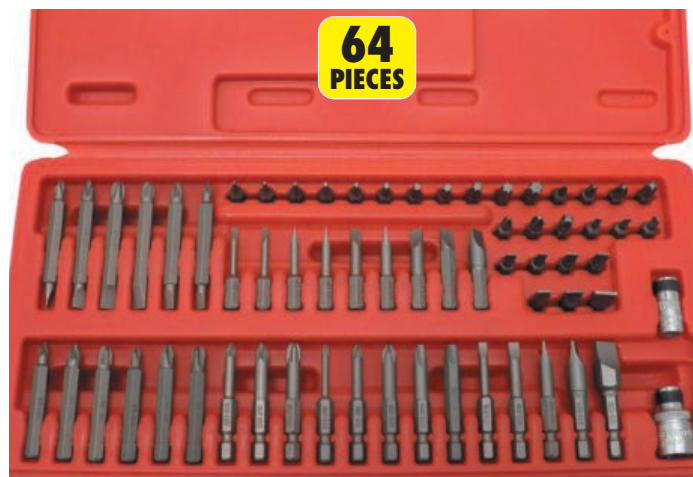

Number of Pieces	Weight each	Order Code KEN-573	Price/1 TB
64	840g	-6500K	3296.00

GROUP 573 SCREWDRIVER BITS

KENNEDY *Mechanic's Screwdriver Bit Set*
QUALITY INDUSTRIAL TOOLING

Crosspoint: No.1, No.2, No.3.
Pozidriv®: No.1, No.2 (x2), No.3.
Torx®: 6, 7, 8, 9, 10, 15, 20, 25, 27, 30, 40.
Slotted: 3, 3.5, 4, 4.5, 5, 5.5, 6.5, 8mm.
Spline: 5, 6, 8, 10mm.
1/4" hex x 60mm quick release magnetic bit holder.
1/4" square drive.
1/4" hex magnetic bit holder.

Supplied in a moulded case with a belt clip.

**32
PIECES**



Number of Pieces	Case Type	Weight each	Order Code KEN-573	Price/1 TB
32	Moulded	260g	-6320K	917.00

Engineer's Screwdriver Bit Set



Crosspoint: No.1, No.2, No.3.
Pozidriv®: No.1, No.2, No.3.
Torx®: 15, 20.
Slotted: 3.5, 4.5, 5, 5.5, 6.5, 8mm.
Hexagon: 2, 3, 4, 5, 6, 8, 10mm, 3/32", 1/8", 5/32", 3/16", 1/4", 5/16".
Square: 1, 2, 3.
1/4" hex x 60mm quick release magnetic bit holder.
1/4" square drive.
1/4" hex magnetic bit holder.

Supplied in a moulded case with a belt clip.

**32
PIECES**



Number of Pieces	Case Type	Weight each	Order Code KEN-573	Price/1 TB
32	Moulded	270g	-6300K	917.00

Mechanic's Screwdriver Bit Set

Featuring Ken-Grip patented design sockets that grip up to 95% of a rounded fastener and will not damage fasteners. Manufactured from Chrome Vanadium, they will fit a range of non-metric hexagons and E-Torx drive sizes. The screwdriver bits are manufactured from Chrome Molybdenum.

Contents:
Metric sockets: 4mm, 4.5mm, 5mm, 5.5mm, 6mm, 7mm, 8mm, 10mm, 11mm, 12mm, 13mm, 14mm.
Screwdriver bits:
Crosspoint: No 1, No 2, No 3
Pozidriv: No 1, No 2, No 3
Torx: T5, T6, T7, T8, T9, T10, T15, T20, T25, T27, T30, T40.
Slotted: 3.5, 4.5, 5.5, 6.5, 8
Hexagon: 1.5, 2, 2.5, 3, 4, 5, 6, 7, 8
Tri-Wing: No 3, No 4, No 5
Torq Set: TS.5, TS.6, TS.8, TS.10
SIT: No 10, No 20, No 25, No 30, No 40
Accessories: 1/4" Square drive, 1/4" hex magnetic bit holder, Y adaptor for cup hook, Spinner handle



**60
PIECES**

NEW

Number of Pieces	Case Type	Order Code KEN-573	Price/1 TB
60	Metal	-6370K	2350.00

Master Screwdriver Bit Set

1/4" hex x 25mm insert bits. Manufactured from chrome molybdenum. Bit holder made from chrome vanadium hardened steel, tempered and chrome plated. Uniquely packaged in a moulded plastic case for easy organisation and storage.

Crosspoint: No.0, No.1, No.2R, No.2, No.3, No.4.
Pozidriv®: No.0, No.1, No.2, No.3, No.4.
Square: 0, 1, 2, 3, 4.
Torx®: T6, T7, T8, T9, T10, T15, T20, T25, T27, T30, T40, T45, T50.
Clutch: 5/32, 3/16, 1/4.
Hex: 1.5, 2, 2.5, 3, 4, 5, 6, 7, 8, 10.
Slotted: 3, 3.5, 4.5, 5.5, 6.5.
Crosspoint ACR II: No.1, No.2R, No.2, No.3.
Pozidriv® ACR: No.1, No.2, No.3.
Spline: 4, 5, 6, 8.

Torq®Set: 4, 5, 8, 10, 1/4".
Spanner: 4, 6, 8, 10, 12.
Torx® Tamper Resistant: T6, T7, T8, T9, T10, T15, T20, T25, T27, T30, T40.
Hex Tamper Resistant: 1.5, 2, 2.5, 3, 4, 5, 5.5, 6, 7, 8.
Tri-Wing: No.1, No.2, No.3, No.4, No.5.
1/4" square drive x 1/4" hex magnetic bit holder - 25mm.
1/4" hex x 1/4" hex magnetic bit holder - 60mm.
1/4" hex x 1/4" square drive socket adaptor - 25mm.
1/4" hex x 1/4" square drive socket adaptor - 50mm.
"Y" Adaptor for cup hook or screw eye.

Dimensions (H x W x D): 123 x 177 x 35mm.



**100
PIECES**

Number of Pieces	Case Type	Weight each	Order Code KEN-573	Price/1 TB
100	Moulded	690g	-6350K	2300.00

HAND TOOLS



KENNEDY *Impact*
QUALITY INDUSTRIAL TOOLING **Driver Sets**

Industrial quality impact driver with switchable forward and reverse screwdriver rotation. When the impact resistant handle is struck with a hammer the downward force is converted by the impact driver's internal mechanism into a powerful high torque screwdriver rotation action. Ideal for ensuring fasteners are securely tightened and for freeing stuck fasteners. Hex drive nose pieces can be removed to allow use with 1/2" square drive impact sockets.

14-Piece Set

To suit 5/16" hex, 3/8" and 1/2" square drives. **Complete with: Crosspoint:** No.1, 2, 3 and 4. **Flat Bits:** 6, 8, 10 and 12mm. **Hex Bits:** 4,5, 6 and 8mm.



Number of Pieces	Case Type	Weight each	Order Code KEN-573	Price/1 TB
14	Moulded	1.20kg	-7100K	1006.00

14
PIECES

5-Piece Set

To suit 5/16" hex and 1/2" square drives. **Complete with: Crosspoint:** No.2 and 3. **Flat Bits:** 8 and 10mm.

5
PIECES



Number of Pieces	Weight each	Order Code KEN-573	Price/1 TB
5	0.75kg	-7080K	620.00



40-Piece Set

1/2" square to 5/16" hexagon bit adaptor 1/2" square to 3/8" hexagon bit adaptor.
80mm x 3/8" Hexagon bits, Hexagon: 8mm, 6mm, **TX:** Tx40, Tx45, Tx50, **Crosspoint:** No.2, No.3, **Slotted:** 8mm and 10mm,
35mm x 3/8" Hexagon bits, Hexagon: 4mm, 5mm, 6mm, 7mm, 8mm, **TX:** Tx20, Tx25, Tx30, Tx40, Tx45, Tx50,
Crosspoint: No.1, 2, 3 & 4, **Slotted:** 5mm, 6mm, 8mm, 10mm, 12mm,
30mm x 5/16" Hexagon bits, Hexagon: 10mm, 12mm, **TX:** Tx55, **Spline:** 5mm, 6mm, 8mm, 10mm, and 12mm.

40
PIECES



Number of Pieces	Case Type	Weight each	Order Code KEN-573	Price/1 TB
40	Moulded	1.20kg	-7140K	1810.00

PRODUCTS ARE ONLY AVAILABLE VIA YOUR DISTRIBUTOR

HAND TOOLS



Spark-resistant tools are used to eliminate the chances of accidental fires or explosions in potentially combustible or explosive environments. They resist the sparks that a standard tool could potentially create when striking hard surfaces. The use of spark resistant tools is essential in many industrial applications such as petroleum and chemical manufacturing, spray booth operations, the marine industry, the mining industry, the paper industries, or any location where flammable vapours or combustible residues are present.

Spark-resistant tools must be maintained with special care. Frequent cleaning/re-dressing to remove ferrous particles or contaminants, which may impair the spark-resistant properties, is essential.

Safe for use in high risk hazardous locations, Ideal for chemical, pharmaceutical, power, oil and gas and fire rescue.

For gases, vapours and mists the zone classifications are:

- Zone 0 Be-Cu** An atmosphere where a mixture of air and flammable substances in the form of gas, vapour or mist is present frequently, continuously or for long periods.
- Zone 1 Be-Cu Al-Br** An atmosphere where a mixture of air and flammable substances in the form of gas, vapour or mist is likely to occur in normal operation occasionally.
- Zone 2 Be-Cu Al-Br** An atmosphere where a mixture of air and flammable substances in the form of gas, vapour or mist is not likely to occur in normal operation but, if it does occur, will persist for only a short period.

For dusts the zone classifications are:

- Zone 20 Be-Cu** An atmosphere where a cloud of combustible dust in the air is present frequently, continuously or for long periods.
- Zone 21 Be-Cu Al-Br** An atmosphere where a cloud of combustible dust in the air is likely to occur in normal operation occasionally.
- Zone 22 Be-Cu Al-Br** An atmosphere where a cloud of combustible dust in the air is not likely to occur in normal operation but, if it does occur, will persist for only a short period.

Al-Br Aluminium Bronze
are manufactured to 20-30HRC and offer a breaking strain of **782 N/m - 989 N/m.**

Be-Cu Beryllium Copper
are manufactured to 30-40HRC and offer a breaking strain of **1117 N/m - 1236 N/m.**

Screwdrivers



Tip Type		Blade Length	Weight each	Order Code KEN-575	Price/1 TB
CROSSPOINT	No.1	75	55g	-4520K	876.00
	No.2	100	60g	-4540K	1082.00
	No.3	150	100g	-4560K	1545.00
	No.4	200	120g	-4580K	1854.00
PARALLEL	6.0mm	100	60g	-4020K	1066.00
	6.0mm	150	80g	-4040K	1492.00
	7.5mm	200	120g	-4060K	1811.00
	9.0mm	250	180g	-4080K	2450.00
	9.0mm	300	200g	-4100K	2982.00

Tip Type		Blade Length	Weight each	Order Code KEN-575	Price/1 TB
CROSSPOINT	No.1	75	55g	-4420K	1597.00
	No.2	100	60g	-4440K	1803.00
	No.3	150	100g	-4460K	2575.00
	No.4	200	120g	-4480K	3089.00
PARALLEL	6.0mm	100	60g	-3960K	1545.00
	6.0mm	150	80g	-3970K	2059.00
	7.5mm	200	120g	-3980K	2318.00
	9.0mm	250	180g	-3990K	3089.00
	9.0mm	300	200g	-4000K	4119.00

Long Nose Pliers

With side cutter, serrated jaws and safety grips.



Overall Length	Weight each	Order Code KEN-575	Price/1 TB
200mm (8")	155g	-3880K	3764.00

Overall Length	Weight each	Order Code KEN-575	Price/1 TB
200mm (8")	335g	-3870K	8755.00

Groove Joint Pliers

Serrated jaws with sliding pivot joint which allows a wide range of jaw opening.



Overall Length	Maximum Capacity	Weight each	Order Code KEN-575	Price/1 TB
250mm	45mm	415g	-3900K	5343.00

Overall Length	Maximum Capacity	Weight each	Order Code KEN-575	Price/1 TB
250mm	45mm	325g	-3890K	9785.00

Adjustable Combination Pliers

Serrated teeth with sliding pivot joint. Overall length: 203mm (8").



Overall Length	Weight each	Order Code KEN-575	Price/1 TB
200mm (8")	335g	-3940K	5490.00

Linesman Pliers

Serrated jaws for gripping nuts, bolts, studs etc. with side cutter and slip guard safety handles.



Overall Length	Weight each	Order Code KEN-575	Price/1 TB
150mm (6")	165g	-3800K	3271.00
180mm (7")	310g	-3810K	3716.00
200mm (8")	370g	-3820K	4839.00

Overall Length	Weight each	Order Code KEN-575	Price/1 TB
150mm (6")	180g	-3420K	5665.00
180mm (7")	355g	-3440K	6695.00
200mm (8")	465g	-3460K	7725.00

Diagonal Cutting Nippers

The cutting edge is offset at a slight angle to allow close cuts to a flat surface. Slip guard safety handles.



Overall Length	Weight each	Order Code KEN-575	Price/1 TB
150mm (6")	190g	-3850K	4085.00
200mm (8")	285g	-3860K	4400.00

Overall Length	Weight each	Order Code KEN-575	Price/1 TB
150mm (6")	245g	-3830K	5665.00
200mm (8")	410g	-3840K	7725.00

KENNEDY PROFESSIONAL *Open End Slogging Wrenches*

With flat striking faces to allow hammer blows to be used to loosen or tighten stubborn fasteners.



Al-Br

Size	Overall Length	Weight each	Order Code KEN-575	Price/1 TB
24mm	165mm	275g	-6400K	2111.00
27mm	175mm	350g	-6410K	3065.00
30mm	185mm	470g	-6420K	3533.00
32mm	195mm	535g	-6430K	4304.00
36mm	210mm	780g	-6440K	5019.00
41mm	225mm	965g	-6450K	6517.00
46mm	240mm	1140g	-6460K	8209.00
50mm	255mm	1445g	-6470K	9530.00
55mm	270mm	1705g	-6480K	11156.00
60mm	285mm	2015g	-6490K	12106.00
65mm	305mm	3060g	-6500K	12434.00
70mm	325mm	3620g	-6510K	12824.00
75mm	345mm	3905g	-6520K	13327.00

Beryllium Copper

Be-Cu

Size	Overall Length	Weight each	Order Code KEN-575	Price/1 TB
24mm	165mm	245g	-6360K	4119.00
27mm	175mm	335g	-6362K	5149.00
30mm	185mm	435g	-6364K	6179.00
36mm	210mm	800g	-6368K	8239.00
41mm	225mm	955g	-6370K	10815.00
46mm	240mm	1225g	-6372K	12618.00
50mm	255mm	1560g	-6374K	14419.00
55mm	270mm	1850g	-6376K	15965.00
60mm	285mm	2190g	-6378K	20085.00
65mm	305mm	3060g	-6380K	24205.00
70mm	325mm	4030g	-6382K	28325.00

Single Open End Spanners



Al-Br

Size	Overall Length	Weight each	Order Code KEN-575	Price/1 TB
10mm	103mm		-5020K	2067.00
14mm	125mm		-5040K	2791.00
17mm	143mm		-5060K	3514.00
19mm	157mm		-5080K	4548.00
24mm	195mm		-5100K	5995.00
27mm	221mm		-5120K	6822.00
30mm	258mm		-5140K	6200.00
32mm	272mm		-5160K	7441.00
36mm	300mm		-5180K	8371.00

Beryllium Copper

Be-Cu

Size	Overall Length	Weight each	Order Code KEN-575	Price/1 TB
27mm	221mm	285g	-4720K	5665.00
30mm	258mm	320g	-4740K	6695.00



For Industrial Spanners see Group **582**

Ring End Slogging Wrenches

With flat striking faces to allow hammer blows to be used to loosen or tighten stubborn fasteners.



Al-Br

Size	Overall Length	Weight each	Order Code KEN-575	Price/1 TB
24mm	140mm	250g	-6600K	2098.00
27mm	150mm	350g	-6610K	2683.00
30mm	165mm	460g	-6620K	3519.00
32mm	180mm	610g	-6630K	4299.00
36mm	210mm	780g	-6640K	5419.00
41mm	225mm	985g	-6650K	8233.00
46mm	245mm	1275g	-6660K	9351.00
50mm	255mm	1545g	-6670K	10976.00
55mm	265mm	1720g	-6680K	12834.00
60mm	275mm	2080g	-6690K	13505.00
65mm	290mm	2440g	-6700K	14263.00
70mm	300mm	2735g	-6710K	15980.00
75mm	315mm	3190g	-6720K	18043.00
80mm	342mm	3320g	-6725K	19627.00

Beryllium Copper

Be-Cu

Size	Overall Length	Weight each	Order Code KEN-575	Price/1 TB
24mm	140mm	235g	-6800K	4119.00
27mm	150mm	350g	-6810K	5149.00
30mm	165mm	475g	-6820K	6179.00
32mm	180mm	490g	-6825K	7209.00
36mm	210mm	580g	-6830K	8239.00
41mm	225mm	755g	-6840K	11329.00
46mm	245mm	990g	-6850K	13389.00
50mm	255mm	1145g	-6860K	15449.00
55mm	265mm	1440g	-6870K	19569.00
60mm	275mm	1620g	-6880K	20599.00
65mm	290mm	1995g	-6890K	22659.00

Combination Spanners



Al-Br

Size	Overall Length	Weight each	Order Code KEN-575	Price/1 TB
8mm	125mm	40g	-6020K	2130.00
10mm	138mm	59g	-6040K	2130.00
11mm	141mm	65g	-6060K	2130.00
12mm	146mm	78g	-6080K	2237.00
13mm	156mm	89g	-6100K	2344.00
14mm	168mm	98g	-6120K	2344.00
15mm	176mm	100g	-6140K	2556.00
16mm	185mm	130g	-6160K	2556.00
17mm	197mm	148g	-6180K	2769.00
18mm	205mm	168g	-6200K	2769.00
19mm	216mm	190g	-6220K	3195.00
21mm	235mm	235g	-6240K	3514.00
22mm	248mm	260g	-6260K	3514.00
24mm	268mm	335g	-6280K	4046.00
27mm	288mm	444g	-6300K	4685.00
32mm	330mm	703g	-6320K	9367.00
36mm	345mm	1002g	-6340K	11390.00

Beryllium Copper

Be-Cu

Size	Overall Length	Weight each	Order Code KEN-575	Price/1 TB
8mm	125mm	37g	-5620K	2059.00
10mm	138mm	55g	-5640K	2524.00
11mm	141mm	75g	-5660K	3089.00
12mm	146mm	75g	-5680K	3296.00
13mm	156mm	122g	-5700K	3605.00
14mm	168mm	122g	-5720K	3605.00
15mm	176mm	160g	-5740K	3863.00
16mm	185mm	160g	-5760K	3863.00
17mm	197mm	160g	-5780K	4119.00
18mm	205mm	210g	-5800K	4326.00
19mm	216mm	210g	-5820K	4429.00
21mm	235mm	225g	-5840K	5149.00
22mm	248mm	250g	-5860K	5665.00
24mm	268mm	260g	-5880K	6179.00
27mm	288mm	420g	-5900K	9269.00
32mm	330mm	670g	-5920K	10815.00
36mm	345mm	890g	-5940K	15450.00

HAND TOOLS

GROUP 575 SAFETY TOOLS

KENNEDY PROFESSIONAL Pipe Wrenches

Serrated jaws with knurled adjusting nut.
Heavy Duty



Al-Br

Aluminium Bronze		Weight each	Order Code KEN-575	Price/1 TB
Overall Length	Jaw Capacity			
250mm	30mm	0.80kg	-3580K	3871.00
300mm	40mm	1.20kg	-3600K	6127.00
350mm	50mm	1.55kg	-3620K	7856.00
450mm	60mm	2.45kg	-3640K	11845.00
600mm	75mm	3.65kg	-3660K	14935.00

Beryllium Copper		Weight each	Order Code KEN-575	Price/1 TB
Overall Length	Jaw Capacity			
250mm	30mm	0.73kg	-3700K	7725.00
300mm	40mm	1.05kg	-3720K	8240.00
350mm	50mm	1.31kg	-3740K	15450.00
450mm	60mm	2.25kg	-3760K	19055.00
600mm	75mm	3.46kg	-3780K	25750.00

Adjustable Wrenches

Smooth jaw adjustment with self-locking design which prevents the jaws opening unintentionally under load.



Al-Br

Aluminium Bronze		Weight each	Order Code KEN-575	Price/1 TB
Overall Length	Opening Capacity			
150mm	18mm	120g	-1060K	2833.00
200mm	24mm	255g	-1080K	5511.00
250mm	30mm	410g	-1100K	6438.00
300mm	36mm	655g	-1120K	7777.00

Beryllium Copper		Weight each	Order Code KEN-575	Price/1 TB
Overall Length	Opening Capacity			
150mm	18mm	135g	-0860K	3605.00
200mm	24mm	281g	-0880K	4635.00
250mm	30mm	440g	-0900K	5665.00
300mm	36mm	720g	-0920K	7725.00

Sliding T-Handles

The sliding bar gives many options for leverage within a given space. Fitted with a spring-loaded ball bearing socket retainer.



Al-Br

Aluminium Bronze		Weight each	Order Code KEN-575	Price/1 TB
Square Drive	Overall Length			
1/2"	250mm	310g	-7020K	5974.00
3/4"	400mm	980g	-8020K	6990.00

Speed Brace 1/2" Square Drive

Revolving grip, ideal for nut spinning. Fitted with a spring-loaded ball bearing socket retainer.

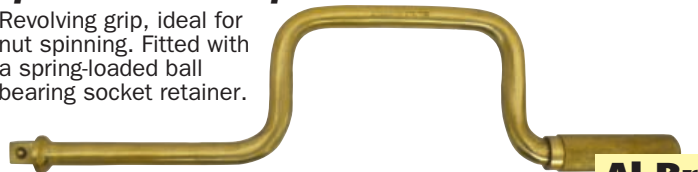

Al-Br

Aluminium Bronze		Weight each	Order Code KEN-575	Price/1 TB
Overall Length				
400mm		700g	-7080K	4212.00

Sledge Hammers

Spark-resistant sledge hammers with wooden handles.



Al-Br

Aluminium Bronze		Weight each	Order Code KEN-575	Price/1 TB
Head Size	Length Capacity			
1.0kg	400mm (16")	1.30kg	-3200K	4738.00
2.5kg	900mm (35")	3.41kg	-3240K	8755.00
3.0kg	900mm (35")	3.91kg	-3260K	10815.00
8.0kg	900mm (35")	8.91kg	-3300K	25750.00

Ball Pein Hammers

For use with cold chisels, punches, rivets and for shaping metal. Fine grain hardwood shaft.



Al-Br

Aluminium Bronze		Weight each	Order Code KEN-575	Price/1 TB
Head Weight	Overall Length (mm)			
1lb	310	680g	-3020K	2215.00
1 1/2lb	340	950g	-3040K	3245.00
2lb	350	1205g	-3060K	3348.00

Beryllium Copper		Weight each	Order Code KEN-575	Price/1 TB
Head Weight	Overall Length (mm)			
1lb	310	680g	-2920K	3863.00
1 1/2lb	340	950g	-2930K	4635.00
2lb	350	1205g	-2940K	5665.00

Ratchet Handle

Disc type adjustment with knurled grip and spring loaded ball bearing socket retainer.



Al-Br

Aluminium Bronze		Weight each	Order Code KEN-575	Price/1 TB
Square Drive	Overall Length			
1/2"	245mm	615g	-7000K	6480.00
3/4"	320mm	1430g	-8000K	12261.00

Beryllium Copper		Weight each	Order Code KEN-575	Price/1 TB
Square Drive	Overall Length			
1/2"	245mm	690g	-6960K	10815.00

1/2" Square Drive Swivel Handle

The hinged link allows operation at varied angles to aid access in restricted areas. Fitted with a spring loaded ball bearing socket retainer.



Al-Br

Aluminium Bronze		Weight each	Order Code KEN-575	Price/1 TB
Overall Length				
250mm		310g	-7100K	4821.00

HAND TOOLS

KENNEDY PROFESSIONAL Safety Extensions

Fitted with a spring-loaded ball bearing socket retainer.



Aluminium Bronze					
Square Drive	Overall Length	Weight each	Order Code KEN-575	Price/1 TB	
1/2"	125mm	230g	-7040K	3653.00	
1/2"	250mm	455g	-7060K	4223.00	
3/4"	200mm	870g	-8040K	5302.00	

Sockets

12 point bi-hexagon.



Aluminium Bronze					
Size	Overall Length	Weight each	Order Code KEN-575	Price/1 TB	
1/2" Drive					
10mm	40mm	71g	-7220K	2221.00	
11mm	40mm	72g	-7200K	1951.00	
12mm	40mm	72g	-7230K	2043.00	
13mm	40mm	73g	-7240K	2628.00	
14mm	40mm	73g	-7260K	2720.00	
17mm	40mm	80g	-7280K	3089.00	
19mm	42mm	100g	-7300K	3245.00	
21mm	43mm	125g	-7320K	3333.00	
22mm	43mm	130g	-7330K	3605.00	
24mm	43mm	170g	-7340K	4223.00	
27mm	43mm	215g	-7380K	4326.00	
30mm	46mm	260g	-7400K	4810.00	
32mm	46mm	290g	-7420K	5302.00	
3/4" Drive					
21mm	55mm	245g	-8220K	2987.00	
24mm	55mm	280g	-8240K	3604.00	
27mm	55mm	285g	-8260K	4427.00	
30mm	60mm	370g	-8280K	5261.00	
32mm	60mm	410g	-8300K	5838.00	
34mm	60mm	440g	-8320K	6389.00	
36mm	60mm	465g	-8340K	7144.00	
38mm	60mm	510g	-8360K	7498.00	
41mm	65mm	640g	-8380K	8259.00	
46mm	65mm	705g	-8400K	9785.00	
50mm	70mm	840g	-8420K	10314.00	

Impact Sockets

12-point, for additional torque grip.



Aluminium Bronze					
Size	Overall Length	Weight each	Order Code KEN-575	Price/1 TB	
3/4" Drive					
27mm	55mm	360g	-8530K	3600.00	
36mm	60mm	565g	-8560K	7070.00	
40mm	65mm	765g	-8580K	7930.00	
50mm	70mm	1003g	-8590K	8846.00	
1" Drive					
24mm	60mm	663g	-8820K	3661.00	
27mm	60mm	672g	-8830K	3966.00	
29mm	60mm	690g	-8840K	4089.00	
34mm	70mm	772g	-8870K	7260.00	
35mm	70mm	825g	-8880K	7321.00	
36mm	70mm	835g	-8890K	7627.00	
38mm	70mm	855g	-8900K	7748.00	

Universal Joint 1/2" Square Drive

Hinged through 180° in both directions for operation at varying angles. Fitted with a spring-loaded ball bearing socket retainer.



Aluminium Bronze					
Overall Length	Weight each	Order Code KEN-575	Price/1 TB		
50mm	170g	-7120K	2311.00		

Socket Set 1/2" Square Drive

Sockets: 10, 11, 12, 14, 17, 19, 22, 24, 27, 30 and 32mm.
Accessories: 250mm ratchet wrench, 250mm sliding T-handle, 400mm speed brace, 125 and 250mm socket extensions.



Aluminium Bronze					
Number of Pieces	Weight each	Order Code KEN-575	Price/1 TB		
16	4.50kg	-7500K	55403.00		

Beryllium Copper					
Number of Pieces	Weight each	Order Code KEN-575	Price/1 TB		
16	6.73kg	-7460K	92700.00		

Socket Set 3/4" Square Drive

Sockets: 21, 24, 27, 30, 32, 34, 36, 38, 41, 46 and 50mm.
Accessories: 320mm ratchet wrench, 400mm sliding T-handle, 200mm socket extension.



Aluminium Bronze					
Number of Pieces	Weight each	Order Code KEN-575	Price/1 TB		
14	9.10kg	-8500K	90024.00		

Beryllium Copper					
Number of Pieces	Weight each	Order Code KEN-575	Price/1 TB		
14	13.24kg	-8460K	164800.00		

HAND TOOLS

GROUP 575 SAFETY TOOLS

KENNEDY PROFESSIONAL Square Shovel

Spark resistant shovel with square mouth, polypropylene 'YD' handle and wooden shaft.



Blade size: 235 x 185mm.
Overall length: 950mm.

Al-Br

Head Size	Overall Length	Weight each	Order Code KEN-575	Price/1 TB
235 x 185mm	950mm (37")	1.80kg	-9240K	7627.00

Wrecking Bars

For general dismantling and stripping applications. V-notch for use on nails.

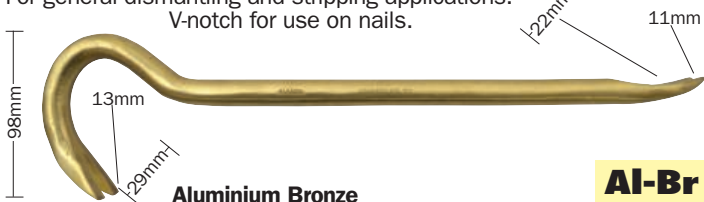

Aluminium Bronze

Al-Br

Overall Length	Weight each	Order Code KEN-575	Price/1 TB
400mm	685g	-2520K	7725.00

Beryllium Copper

Be-Cu

Overall Length	Weight each	Order Code KEN-575	Price/1 TB
400mm	752g	-2400K	8240.00

Drift Punches

Tapered punch, used for the purpose of aligning holes between two structural members so that they can be fastened or bolted together.



Al-Br

Size	Overall Length	Weight each	Order Code KEN-575	Price/1 TB
3mm	160mm (6")	290g	-1600K	1906.00

Beryllium Copper

Be-Cu

Size	Overall Length	Weight each	Order Code KEN-575	Price/1 TB
3mm	160mm (6")	280g	-1560K	4635.00

Putty Knives

With a chisel point and bi-material handle.



Al-Br

Blade Length	Blade Width	Overall Length	Order Code KEN-575	Price/1 TB
100mm (4")	25mm (1")	200mm (8")	-2740K	1906.00

Beryllium Copper

Be-Cu

Blade Length	Blade Width	Overall Length	Order Code KEN-575	Price/1 TB
100mm (4")	25mm (1")	200mm (8")	-2760K	2575.00

Scrapers



Al-Br

Blade Length	Blade Width	Overall Length	Order Code KEN-575	Price/1 TB
95mm (3 3/4")	75mm (3")	200mm (8")	-2860K	1957.00

Beryllium Copper

Be-Cu

Blade Length	Blade Width	Overall Length	Order Code KEN-575	Price/1 TB
95mm (3 3/4")	75mm (3")	200mm (8")	-2880K	3605.00

Wedges



Al-Br

Dimensions	Weight each	Order Code KEN-575	Price/1 TB
80 x 13 x 6mm	25g	-0500K	178.00
135 x 50 x 18mm	497g	-0510K	2910.00
150 x 25 x 13mm	205g	-0520K	1038.00
180 x 32 x 13mm	305g	-0540K	1349.00
180 x 50 x 19mm	700g	-0560K	3356.00
200 x 50 x 13mm	500g	-0580K	2380.00
200 x 30 x 30mm	1315g	-0600K	2783.00
200 x 40 x 40mm	1200g	-0620K	7016.00

Beryllium Copper

Be-Cu

Dimensions	Weight each	Order Code KEN-575	Price/1 TB
80 x 13 x 6mm	25g	-0320K	464.00
135 x 50 x 18mm	497g	-0340K	3605.00
150 x 25 x 13mm	205g	-0360K	1288.00
180 x 32 x 13mm	305g	-0380K	2575.00
180 x 50 x 19mm	700g	-0400K	5665.00
200 x 50 x 13mm	540g	-0420K	4635.00
200 x 30 x 30mm	740g	-0440K	5665.00
200 x 40 x 40mm	1315g	-0460K	8755.00

Marking Tool

Double-ended spark resistant marking tool.

Overall length: 190mm.



Al-Br

Overall Length	Weight each	Order Code KEN-575	Price/1 TB
190mm (7 1/2")	20g	-1800K	1160.00

Chisel Cross

4-point spark resistant chisel with 20mm wide hexagon shaft. Length: 200mm.



Al-Br

Size	Overall Length	Weight each	Order Code KEN-575	Price/1 TB
7mm	200mm (8")	290g	-2300K	3581.00

Flat Cold Chisels



Al-Br

Size (mm)	Overall Length (mm)	Weight each	Order Code KEN-575	Price/1 TB
14	160	160g	-2020K	1219.00
16	160	210g	-2040K	1219.00
18	200	345g	-2060K	1219.00
20	200	430g	-2080K	1846.00
20	300	645g	-2100K	3089.00
25	240	800g	-2120K	4317.00
25	300	1000g	-2140K	4742.00
25	400	1360g	-2160K	5125.00

Beryllium Copper

Be-Cu

Size (mm)	Overall Length (mm)	Weight each	Order Code KEN-575	Price/1 TB
14	160	175g	-1860K	4635.00
16	160	231g	-1880K	5665.00
18	200	382g	-1900K	5923.00
20	200	473g	-1920K	6179.00
20	300	710g	-1940K	6695.00
25	240	1042g	-1960K	7209.00

HAND TOOLS



KENNEDY *Open Jaw Spanners*
QUALITY INDUSTRIAL TOOLING®

Made from forged and hardened steel. Black oxidised finish. Conform to **DIN 894**. **Single-Ended**



Size (mm)	Overall Length	Weight each	Order Code KEN-580	Price/1 TB
6	77	10g	-1060K	76.00
7	78	10g	-1070K	76.00
8	95	20g	-1080K	76.00
9	100	20g	-1090K	88.00
10	105	25g	-1100K	88.00
11	125	34g	-1110K	88.00
12	125	36g	-1120K	95.00
13	135	44g	-1130K	95.00
14	140	52g	-1140K	107.00
15	140	49g	-1150K	146.00
17	160	57g	-1170K	146.00
18	160	65g	-1180K	146.00
19	170	86g	-1190K	146.00
22	195	118g	-1220K	146.00
24	205	145g	-1240K	182.00
27	235	225g	-1270K	169.00
30	260	285g	-1300K	290.00
32	265	330g	-1320K	322.00
36	300	428g	-1360K	352.00
38	300	424g	-1380K	503.00
41	345	545g	-1410K	509.00
46	375	800g	-1460K	824.00
50	410	980g	-1500K	1075.00
55	455	1260g	-1550K	1263.00
60	490	1650g	-1600K	1515.00
65	575	1895g	-1650K	1955.00
70	570	2340g	-1700K	2910.00
75	610	2610g	-1750K	3576.00
80	645	3330g	-1800K	5974.00
85	690	3490g	-1850K	8601.00
90	850	3455g	-1900K	9631.00
95	900	3500g	-1950K	14626.00

Double-Ended
Conform to **DIN 895**.



Size (mm)	Overall Length	Weight each	Order Code KEN-580	Price/1 TB
6x7	95	12g	-3060K	61.00
7x8	108	20g	-3080K	61.00
8x9	117	28g	-3100K	61.00
8x10	115	28g	-3140K	85.00
9x11	122	28g	-3180K	85.00
10x11	122	31g	-3200K	102.00
10x13	123	45g	-3240K	102.00
11x13	140	54g	-3280K	103.00
12x13	140	50g	-3300K	103.00
12x14	142	55g	-3320K	103.00
13x14	142	53g	-3340K	116.00
13x15	160	69g	-3360K	134.00
13x17	160	74g	-3380K	134.00
14x15	160	74g	-3420K	134.00
14x17	160	70g	-3460K	134.00
16x18	170	104g	-3540K	134.00
17x19	170	99g	-3580K	164.00
17x21	193	143g	-3620K	186.00
19x22	195	119g	-3700K	208.00
19x24	205	191g	-3740K	208.00
22x24	220	216g	-3820K	248.00
24x27	244	257g	-3900K	312.00
24x30	265	283g	-4000K	372.00
30x32	273	450g	-4100K	541.00
30x36	305	528g	-4150K	556.00
32x36	305	534g	-4200K	615.00
36x41	340	705g	-4250K	646.00
41x46	380	985g	-4300K	677.00
46x50	420	1170g	-4350K	1208.00
50x55	460	1530g	-4400K	1775.00
55x60	500	1645g	-4500K	2162.00

Reversible Ratchet Podger Spanners

Chrome vanadium steel. Suitable for heavy-duty construction applications. Ratchet action for use in confined spaces. Reversible head has two internal bi-hexagon sizes. Podger wrenches have tapered handle for alignment of fixing holes on jigs and fabrications.



Size	Order Code KEN-580	Price/1 TB
13 & 17mm	-8430K	611.00
17 & 19mm	-8450K	1220.00
19 & 24mm	-8460K	1635.00
24 & 27mm	-8470K	1635.00
27 & 30mm	-8480K	2722.00
30 & 32mm	-8490K	2859.00

Open End Podger Spanners

Designed to engage the nut from the side. As it only engages on two faces of the fastener, care must be taken to ensure that the correct size spanner is always used. Tapered handle for assisting with alignment of fixing holes on jigs and fabrications.



Size	Overall Length	Order Code KEN-580	Price/1 TB
17mm	220	-8510K	519.00
19mm	240	-8520K	586.00
24mm	280	-8530K	705.00
27mm	300	-8540K	867.00
30mm	320	-8550K	1123.00
32mm	340	-8560K	1321.00
36mm	355	-8570K	1539.00
46mm	390	-8590K	2429.00

Ring End Podger Spanners

Cranked handle assists with location of spanner on to fixings within a recess.



Size	Overall Length	Order Code KEN-580	Price/1 TB
17mm	275	-8710K	560.00
19mm	305	-8720K	612.00
24mm	345	-8730K	750.00
27mm	365	-8740K	891.00
30mm	400	-8750K	1198.00
32mm	425	-8760K	1572.00
36mm	460	-8770K	1572.00
46mm	505	-8790K	2639.00

Ring Slogging Spanners

Manufactured from forged and hardened steel with machined drive faces to ensure good contact with the fastener. With flat striking faces to allow hammer blows to be used to loosen or tighten stubborn fasteners. Manufactured to **DIN 7444**.



Size (mm)	Overall Length	Weight each	Order Code KEN-580	Price/1 TB
Metric				
24	165	0.40kg	-7010K	874.00
27	180	0.40kg	-7020K	1149.00
30	190	0.50kg	-7030K	1367.00
32	190	0.50kg	-7040K	1421.00
36	205	0.50kg	-7050K	1858.00
41	230	0.80kg	-7060K	2378.00
46	240	1.00kg	-7070K	2515.00
50	225	1.10kg	-7080K	2950.00
55	270	1.50kg	-7090K	3307.00
60	280	1.80kg	-7100K	3497.00
65	300	2.20kg	-7110K	4590.00
70	330	3.30kg	-7120K	5027.00
75	330	3.30kg	-7130K	5432.00
80	360	4.00kg	-7140K	8087.00
85	360	4.00kg	-7150K	9617.00
90	390	5.50kg	-7160K	12568.00
95	420	5.30kg	-7170K	13223.00
100	420	6.50kg	-7180K	14753.00
105	420	6.50kg	-7190K	16392.00
110	450	8.00kg	-7200K	19670.00
115	450	7.80kg	-7210K	27319.00
120	480	10.0kg	-7220K	28412.00
125	480	9.70kg	-7230K	29505.00
130	520	13.2kg	-7240K	63379.00
135	520	13.0kg	-7250K	66657.00
140	520	18.5kg	-7260K	78677.00
145	580	18.5kg	-7270K	104903.00
150	580	18.2kg	-7280K	112552.00

Size	Overall Length	Weight each	Order Code KEN-580	Price/1 TB
Inch				
1 1/16"	180	0.40kg	-7500K	1195.00
1 1/8"	180	0.40kg	-7510K	1195.00
1 3/16"	190	0.50kg	-7520K	1195.00
1 1/4"	190	0.50kg	-7530K	1421.00
1 5/16"	190	0.50kg	-7540K	1242.00
1 3/8"	205	0.50kg	-7550K	2556.00
1 7/16"	205	0.50kg	-7560K	2556.00
1 1/2"	205	0.50kg	-7570K	2556.00
1 9/16"	230	0.80kg	-7580K	2515.00
1 5/8"	230	0.80kg	-7590K	2515.00
1 11/16"	230	0.80kg	-7600K	2515.00
1 3/4"	240	1.00kg	-7610K	2639.00
1 13/16"	240	1.00kg	-7620K	2639.00
1 7/8"	240	1.00kg	-7630K	2639.00
1 15/16"	225	1.10kg	-7640K	2766.00
2"	225	1.10kg	-7650K	2891.00
2 1/16"	225	1.10kg	-7660K	3017.00
2 1/8"	270	1.50kg	-7670K	3017.00
2 3/16"	270	1.50kg	-7680K	3142.00
2 1/4"	270	1.50kg	-7690K	3269.00
2 5/16"	280	1.80kg	-7700K	3393.00
2 3/8"	280	1.80kg	-7710K	3520.00
2 7/16"	280	1.80kg	-7720K	3583.00
2 1/2"	300	2.20kg	-7730K	3708.00
2 9/16"	300	2.20kg	-7740K	3771.00
2 5/8"	300	2.20kg	-7750K	4085.00
2 3/4"	330	3.30kg	-7760K	4337.00
2 13/16"	330	3.30kg	-7770K	8234.00
2 7/8"	330	3.30kg	-7780K	8798.00
2 15/16"	330	3.30kg	-7790K	9426.00
3"	330	3.30kg	-7800K	10054.00
3 1/8"	360	4.50kg	-7810K	10370.00
3 1/4"	360	4.50kg	-7820K	13387.00
3 1/2"	390	5.50kg	-7840K	13824.00
3 5/8"	420	5.30kg	-7850K	18852.00
3 3/8"	420	6.50kg	-7870K	25134.00
4 1/4"	450	8.00kg	-7900K	26391.00
4 5/8"	450	7.80kg	-7920K	35010.00

HAND TOOLS



Open Jaw Slogging Spanners

Forged and hardened steel. Flat striking faces to allow hammer blows to be used to loosen or tighten stubborn fasteners. To **DIN 133**.



Size (mm)	Overall Length	Weight each	Order Code KEN-580	Price/1 TB
Metric				
24	180	0.40kg	-6010K	788.00
27	180	0.40kg	-6020K	874.00
30	190	0.50kg	-6030K	1078.00
32	190	0.50kg	-6040K	1092.00
36	215	0.50kg	-6050K	1455.00
41	235	0.90kg	-6060K	1639.00
46	225	1.20kg	-6070K	2242.00
50	275	1.20kg	-6080K	2569.00
55	300	1.90kg	-6090K	2842.00
60	320	2.60kg	-6100K	3335.00
65	340	3.40kg	-6110K	4590.00
70	375	4.40kg	-6120K	5574.00
75	375	4.40kg	-6130K	7649.00
80	410	6.30kg	-6140K	8742.00
85	410	6.30kg	-6150K	9835.00
90	445	7.30kg	-6160K	10382.00
95	445	7.30kg	-6170K	11475.00
100	485	12.2kg	-6180K	13660.00
105	485	12.2kg	-6190K	14753.00
110	510	13.5kg	-6200K	15846.00
115	510	13.5kg	-6210K	16938.00

Inch (AF Sizes)				
1 1/16"	180	0.40kg	-6500K	1046.00
1 1/8"	180	0.40kg	-6510K	1060.00
1 3/16"	190	0.40kg	-6520K	1412.00
1 1/4"	190	0.50kg	-6530K	1591.00
1 5/16"	215	0.50kg	-6540K	2176.00
1 3/8"	215	0.50kg	-6550K	2494.00
1 7/16"	215	0.55kg	-6560K	2759.00
1 1/2"	235	0.55kg	-6570K	3237.00
1 9/16"	235	0.55kg	-6580K	4456.00
1 5/8"	235	0.90kg	-6590K	5411.00
1 11/16"	255	0.90kg	-6600K	7426.00
1 3/4"	225	0.90kg	-6610K	8487.00
1 13/16"	225	1.20kg	-6620K	9548.00
1 7/8"	225	1.20kg	-6630K	10079.00
1 15/16"	275	1.50kg	-6640K	11140.00
2"	275	1.50kg	-6650K	13262.00
2 1/16"	275	1.50kg	-6660K	14323.00
2 1/8"	300	1.70kg	-6670K	14323.00
2 3/16"	300	1.90kg	-6680K	14323.00
2 1/4"	300	1.90kg	-6690K	14323.00
2 5/16"	320	2.60kg	-6700K	14323.00
2 3/8"	320	2.60kg	-6710K	14323.00
2 7/16"	320	2.60kg	-6720K	14323.00
2 1/2"	340	3.40kg	-6730K	14323.00
2 9/16"	340	3.40kg	-6740K	14323.00
2 5/8"	340	3.40kg	-6750K	14323.00
2 3/4"	375	4.40kg	-6760K	14323.00
2 13/16"	375	4.40kg	-6770K	14323.00
2 7/8"	375	4.40kg	-6780K	14323.00
2 15/16"	375	4.40kg	-6790K	14323.00
3"	375	4.40kg	-6800K	14853.00
3 1/8"	410	6.30kg	-6810K	14959.00
3 1/2"	445	7.30kg	-6840K	15065.00
3 5/8"	445	7.30kg	-6850K	15171.00
3 7/8"	485	12.20kg	-6870K	15384.00
4 1/4"	510	13.50kg	-6900K	15914.00

C-Hook Spanners

Chrome vanadium steel. Specifically designed for use with slotted retaining rings. Conform to **DIN 1810A**.

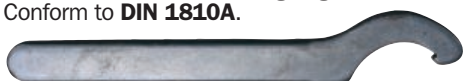

Range (mm)	Overall Length	Weight each	Order Code KEN-580	Price/1 TB
16/20	108	20g	-5160K	397.00
25/28	135	45g	-5250K	423.00
34/36	170	90g	-5340K	423.00
40/42	170	95g	-5400K	423.00
45/50	205	160g	-5450K	423.00
52/55	205	165g	-5520K	541.00
58/62	240	270g	-5580K	616.00
68/75	240	270g	-5680K	698.00
80/90	280	410g	-5800K	1138.00

Scaffolding Tools

Manufactured to surpass the performance test **BS2558: 1954**. The sockets locate directly onto the handle relieving stress on the rivet. All sockets are plated, hardened and stress relieved to ensure they retain their shape.

Double Ended Swing Over Spanner

Swingover handle spanner with a 7/16" Whitworth socket end and 1/2" socket end for use on fixings. Suitable for use with all popular scaffold fixings used in the UK.

Overall length: 320mm.
Bar diameter: 15mm.
Socket size: 7/16"W x 1/2"W.



Socket Size	Weight each	Order Code KEN-580	Price/1 TB
7/16"W x 1/2"W	545g	-9040K	1129.00

Spinner Head Spanner

The handle is produced from a one piece drop forging with a 7/16" and 1/2" Whitworth double ended socket for use on fixings. Features a taper podger end used to line up holes and manipulate fixings. Rotating socket offers a single tool for two fastener sizes.



Overall length: 245mm.
Socket size: 7/16"W x 1/2"W.

Socket Size	Weight each	Order Code KEN-580	Price/1 TB
7/16"W x 1/2"W	490g	-9080K	1343.00

Combination Podger Spanner

Swingover handle spanner with a 7/16" Whitworth socket end for use on fixings. Features a cranked taper square podger end for use on eyebolt and jacking collars.

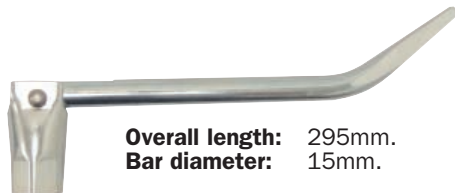

Overall length: 295mm.
Bar diameter: 15mm.



Socket Size	Weight each	Order Code KEN-580	Price/1 TB
7/16"W	430g	-9060K	764.00



Podger Hammer

Manufactured from a one piece forging. Features a hammer end and cranked round taper podger end used to line up holes and manipulate fixings.



Overall length: 275mm.
Bar diameter: 15mm.
Head diameter: 35mm.
Head length: 45mm.



Head Diameter	Weight each	Order Code KEN-580	Price/1 TB
35mm	660g	-9100K	1584.00

Scaffold Key

Manufactured with a hook end and cranked taper square podger end for aligning and tightening eyebolts, jacking collars and loop fixings, both ends are hardened and tempered to improve tool life.

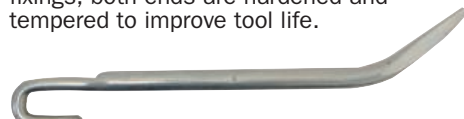

Overall length: 305mm.
Bar diameter: 15mm.
Head width: 20mm.



Head Width	Weight each	Order Code KEN-580	Price/1 TB
20mm	460g	-9070K	567.00

Single Ended Swing Over Spanners

Single ended swingover handle spanners. Available in 7/16" or 1/2" Whitworth socket end size for use on fixings.



Standard



Heavy Duty



Chunky



Size	Bar Dia.	Type	Order Code KEN-580	Price/1 TB
7/16"	15mm	Standard	-9020K	672.00
7/16"	15mm	Heavy Duty	-9010K	1587.00
7/16"	15mm	Chunky	-9050K	714.00
1/2"	20mm	Standard	-9030K	672.00

SPIGOT END FITTINGS/PIN SPANNERS

KENNEDY
QUALITY INDUSTRIAL TOOLING

16mm Spigot End Fittings

Open End

NEW



Size	Weight each	Order Code KEN-581	Price/1 TB
16mm Bore - Metric			
8mm	100g	-2810K	2059.00
10mm	110g	-2820K	2059.00
11mm	110g	-2830K	2059.00
12mm	110g	-2840K	2059.00
13mm	110g	-2850K	2059.00
14mm	120g	-2860K	2059.00
15mm	120g	-2870K	2059.00
16mm	140g	-2880K	2059.00
17mm	140g	-2890K	2059.00
18mm	140g	-2900K	2059.00
19mm	160g	-2910K	2059.00
20mm	160g	-2920K	2059.00
21mm	160g	-2930K	2112.00
22mm	220g	-2940K	2112.00
23mm	220g	-2950K	2112.00
24mm	220g	-2960K	2112.00
25mm	220g	-2970K	2163.00
26mm	220g	-2980K	2215.00
27mm	240g	-2990K	2323.00
30mm	240g	-3000K	2369.00
32mm	240g	-3010K	2421.00
16mm Bore AF (Inch)			
3/8"	100g	-3500K	2575.00
7/16"	110g	-3510K	2575.00
1/2"	120g	-3520K	2575.00
9/16"	120g	-3530K	2575.00
5/8"	140g	-3540K	2575.00
11/16"	140g	-3550K	2575.00
3/4"	160g	-3560K	2575.00
13/16"	220g	-3570K	2575.00
7/8"	220g	-3580K	3060.00
15/16"	220g	-3590K	3060.00
1"	220g	-3600K	3060.00
1 1/16"	240g	-3610K	3060.00
1 1/8"	240g	-3620K	3060.00
1 3/16"	240g	-3630K	3060.00
1 1/4"	240g	-3640K	3060.00

16mm Spigot End Fittings

Ring End

NEW



Size	Weight each	Order Code KEN-581	Price/1 TB
16mm Bore - Metric			
8mm	100g	-4300K	2138.00
10mm	100g	-4310K	2138.00
11mm	100g	-4320K	2138.00
12mm	100g	-4330K	2138.00
13mm	110g	-4340K	2138.00
14mm	110g	-4350K	2138.00
15mm	120g	-4360K	2138.00
16mm	120g	-4370K	2138.00
17mm	120g	-4380K	2138.00
18mm	120g	-4390K	2138.00
19mm	130g	-4400K	2138.00
21mm	130g	-4410K	2210.00
22mm	170g	-4420K	2210.00
24mm	160g	-4430K	2210.00
27mm	150g	-4440K	2210.00
16mm Bore AF (Inch)			
3/8"	100g	-4450K	2550.00
1/2"	100g	-4460K	2550.00
9/16"	100g	-4470K	2550.00

Flare End

NEW



Size	Weight each	Order Code KEN-581	Price/1 TB
16mm Bore - Metric			
10mm	100g	-5200K	2323.00
11mm	100g	-5210K	2323.00
13mm	110g	-5220K	2323.00
14mm	110g	-5230K	2323.00
16mm	120g	-5240K	2323.00
17mm	110g	-5250K	2323.00
18mm	120g	-5260K	2323.00
19mm	120g	-5270K	2323.00
21mm	120g	-5280K	2946.00
22mm	120g	-5290K	2946.00
24mm	120g	-5300K	2946.00
27mm	130g	-5310K	2946.00

16mm Spigot Drives

NEW



Reversible Ratchet Head



Push-Through Ratchet Head

Square Drive	Weight each	Order Code KEN-581	Price/1 TB
Reversible Ratchet Head			
3/8"	190g	-5550K	2421.00
Push-Through Square Drive Head			
1/2"	290g	-5900K	2524.00

Adjustable Pin Wrench

Forged in chrome vanadium steel, the wrench is adjusted by turning the centre screw. It can be used on nuts with bolts bored on the face and is supplied with 8 interchangeable pins which are double round ended for nuts with top holes.



Description	Capacity	Order Code KEN-581	Price/1 TB
Adjustable Pin Wrench	20-100mm	-1300K	3089.00
	2.5-4mm	-1350K	263.00
Pins to Suit	6-8mm	-1360K	263.00
	3-5mm	-1370K	387.00
	7-9mm	-1380K	387.00

NEW

22mm Spigot End Fittings

Open End

NEW



Size	Weight each	Order Code KEN-581	Price/1 TB
22mm Bore - Metric			
30mm	360g	-4000K	3554.00
32mm	370g	-4010K	3554.00
36mm	390g	-4020K	3554.00
41mm	530g	-4030K	3966.00
46mm	530g	-4040K	3966.00

22mm Spigot End Fittings

Ring End

NEW



Size	Weight each	Order Code KEN-581	Price/1 TB
22mm Bore - Metric			
22mm	310g	-5000K	3554.00
24mm	320g	-5010K	3554.00
27mm	330g	-5020K	3554.00
30mm	350g	-5030K	3554.00
32mm	440g	-5040K	3863.00
36mm	400g	-5050K	3863.00
41mm	560g	-5060K	4419.00
46mm	490g	-5070K	4419.00



Group **555**

GROUP 581/582 SPANNERS - BOX/COMBINATION

KENNEDY *Box Spanners*
QUALITY INDUSTRIAL TOOLING

Manufactured from high quality steel tube. Zinc plated for corrosion resistance, each supplied with tommy bar.



Metric				
Size	Length (mm)	Weight each	Order Code KEN-581	Price/1 TB
6 x 7	102	40g	-1060K	99.00
8 x 9	105	60g	-1080K	99.00
10 x 11	103	70g	-1100K	102.00
12 x 13	102	80g	-1120K	110.00
14 x 15	125	140g	-1140K	137.00
16 x 17	127	175g	-1160K	153.00
18 x 19	130	190g	-1180K	177.00
20 x 21	127	190g	-1200K	176.00
22 x 23	150	415g	-1220K	177.00
24 x 25	150	420g	-1240K	190.00
26 x 27	150	425g	-1270K	316.00

AF				
Size	Length (mm)	Weight each	Order Code KEN-581	Price/1 TB
1/4" x 5/16"	103	60g	-1530K	75.00
5/16" x 3/8"	100	60g	-1550K	75.00
3/8" x 7/16"	100	60g	-1560K	75.00
1/2" x 9/16"	125	145g	-1580K	106.00
9/16" x 5/8"	127	150g	-1600K	106.00
11/16" x 3/4"	125	185g	-1630K	135.00

Sets
7 Piece Metric: 6 x 7, 8 x 9, 10 x 11, 12 x 13, 14 x 15, 16 x 17 and 18 x 19mm.
6 Piece AF: 1/4" x 5/16", 5/16" x 3/8", 3/8" x 7/16", 1/2" x 9/16", 9/16" x 5/8" and 11/16" x 3/4".
6 Piece BA: 0 x 1, 2 x 3, 4 x 5, 6 x 7, 8 x 9, 10BA.



Number of Pieces	Weight each	Order Code KEN-581	Price/1 TB
7 Metric	600g	-1450K	449.00
6 Inch	475g	-1950K	567.00
6 BA	175g	-2350K	397.00

YAMOTO *Double Ratchet Combination Spanners*

Available in a range of sizes (8mm-19mm), these combination spanners are made of chrome vanadium steel and have an innovative ratcheting open-end design. The 72-teeth ratcheting system needs only 5° movement to operate ratchet and the spanners are ideal for use in confined spaces. The chrome plated mirror finish prevents oil and dirt from adhering to the tool, making for easier cleaning and preventing rust. Conform to **ASME B107.100-2010**.

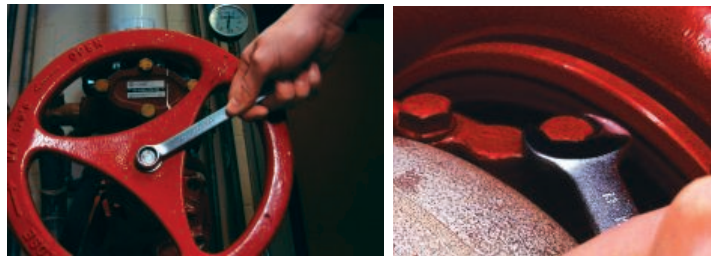
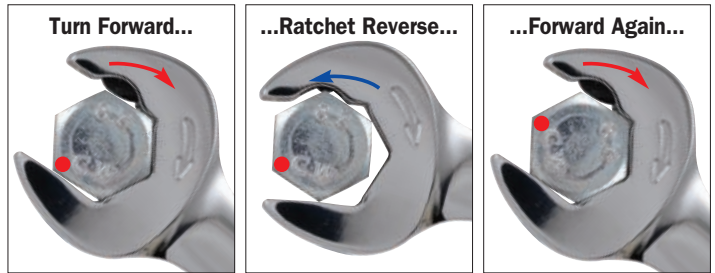

Metric				
Size (mm)	Overall Length	Weight each	Order Code YMT-582	Price/1 TB
8	140	36g	-0340K	567.00
9	150	50g	-0350K	670.00
10	160	57g	-0360K	696.00
11	165	64g	-0370K	696.00
12	170	76g	-0380K	716.00
13	180	101g	-0390K	716.00
14	190	119g	-0400K	747.00
15	200	125g	-0410K	747.00
16	205	170g	-0420K	850.00
17	230	188g	-0430K	979.00
18	235	200g	-0440K	1133.00
19	250	228g	-0450K	1236.00

Set
8 Piece Metric: 8, 10, 12, 13, 14, 15, 17 and 19mm.



Number of Pieces	Order Code YMT-582	Price/1 TB
8 Metric	-0490K	6179.00

HAND TOOLS



KENNEDY PROFESSIONAL Professional Ratchet Combination Spanners

Chrome vanadium steel with mirror polish finish, preventing oil and dirt from adhering to the spanner, making for easier cleaning and preventing rust. 72-teeth ratcheting system which needs only 5° movement to operate ratchet. Thin wall design for greater access. Conform to **ASME B107.6**.



Metric

Size (mm)	Overall Length	Weight each	Order Code KEN-582	Price/1 TB
8	135	38g	-2158K	695.00
10	155	65g	-2160K	766.00
11	160	75g	-2162K	766.00
12	172	85g	-2164K	933.00
13	180	95g	-2166K	933.00
14	190	115g	-2168K	957.00
15	200	135g	-2170K	984.00
16	215	155g	-2172K	1040.00
17	230	200g	-2174K	1364.00
18	240	210g	-2175K	1351.00
19	245	235g	-2176K	1364.00
21	285	350g	-2177K	1476.00
22	285	340g	-2178K	1588.00
24	325	475g	-2179K	1748.00
25	325	480g	-2252K	2023.00
26	325	465g	-2253K	2133.00
27	355	600g	-2254K	2295.00
28	360	600g	-2255K	2515.00
30	420	918g	-2257K	3006.00
32	425	880g	-2259K	3553.00

AF

Size (AF)	Overall Length	Weight each	Order Code KEN-582	Price/1 TB
3/8"	160	60g	-2144K	657.00
7/16"	168	70g	-2146K	667.00
1/2"	179	90g	-2148K	733.00
9/16"	198	115g	-2150K	809.00
5/8"	214	150g	-2152K	908.00
11/16"	232	185g	-2154K	908.00
3/4"	250	225g	-2156K	963.00

Set
9 Piece Metric: 10, 11, 12, 13, 14, 15, 16, 17 and 19mm.
7 Piece AF: 3/8", 7/16", 1/2", 9/16", 5/8", 11/16" and 3/4".



Number of Pieces	Weight each	Order Code KEN-582	Price/1 TB
9 Metric	2560g	-3990K	6728.00
7 AF	2150g	-2230K	3086.00

Ratchet Combination Spanner Set with Sockets

RCS23M - 4 in 1: This wrench set for 10 to 19mm applications comprises open ended wrenches, ratchet ring wrenches, Go-Thru™ single hex ratchet wrenches and 1/4", 3/8" and 1/2" square drive ratchets. All are made from chrome vanadium and are fully plated with a mirror finish. Supplied in a heavy duty fitted metal storage case with locking lid and carry handle.



Ratchet Combination Spanner Set with Sockets

Number of Pieces	Weight each	Order Code KEN-582	Price/1 TB
23	3.00kg	-3980K	7893.00

Square Drive Adaptors

Size	Order Code KEN-582	Price/1 TB
1/4" SD (x10mm hex)	-4210K	155.00
3/8" SD (x13mm hex)	-5195K	191.00
1/2" SD (x19mm hex)	-6705K	170.00

4-in-1 Spanner

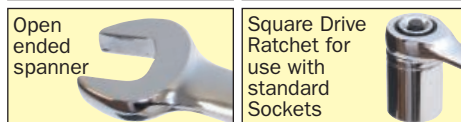
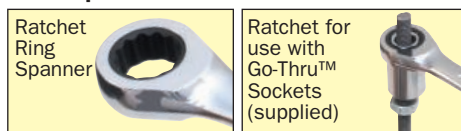

Go-Thru™ Sockets

Size	Order Code KEN-582	Price/1 TB
10mm	-3740K	114.00
11mm	-3741K	114.00
12mm	-3742K	114.00
13mm	-3743K	114.00
14mm	-3744K	114.00
15mm	-3745K	129.00
16mm	-3746K	129.00
17mm	-3747K	132.00
18mm	-3748K	160.00
19mm	-3749K	159.00

PRODUCTS ARE ONLY AVAILABLE VIA YOUR DISTRIBUTOR

HAND TOOLS

GROUP 582 SPANNERS - COMBINATION

KENNEDY PROFESSIONAL Professional Reversible Combination Spanners



Bi-hexagonal 15° offset rings with a 72 teeth lever ratcheting system that requires only 5 degree movement to operate, making them ideal for use in tight areas. Made from high quality Chrome Vanadium Steel with mirror polish finish to prevent oil and dirt from adhering to the spanner. Conform to **ASME B107.6**.



'Flush' fitted reversible switch enables the wrench to move in either direction without sacrificing the overall compact surface of the box end.

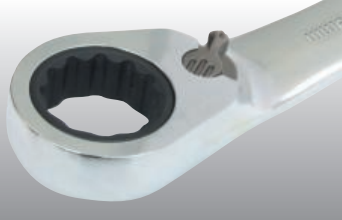

Set
9 Piece Metric: 10, 11, 12, 13, 14, 15, 16, 17 and 19mm.



Metric Size (mm)	Overall Length	Weight each	Order Code KEN-582	Price/1 TB
8	135	32g	-6808K	880.00
10	155	56g	-6810K	936.00
11	160	68g	-6811K	936.00
12	172	78g	-6812K	1017.00
13	180	96g	-6813K	1045.00
14	190	116g	-6814K	1209.00
15	200	136g	-6815K	1209.00
16	215	160g	-6816K	1318.00
17	230	182g	-6817K	1372.00
18	240	200g	-6818K	1427.00
19	245	248g	-6819K	1591.00
21	285	540g	-6821K	1645.00
22	285	540g	-6822K	1755.00
24	325	710g	-6824K	1919.00

9
PIECES

Number of Pieces	Weight each	Order Code KEN-582	Price/1 TB
9 Metric	1.2kg	-6796K	7109.00

Professional Flex-Head Ratchet Combination Spanners

Chrome vanadium steel with mirror polish finish, preventing oil and dirt from adhering to the spanner, making for easier cleaning and preventing rust. 72-teeth ratcheting system which needs only 5° movement to operate ratchet. Thin wall design for greater access. Head flexes up to 90° in either direction. Conform to **ASME B107.6**.



Set (right) contains spanners and ratchet units which combine to make a set of square drive ratchets for use with standard sockets (supplied separately)

Flex-Head Ratchet Combination Spanner Set With Adaptors

Contains:
Flex head ratchet combination spanners: 10, 11, 12, 13, 14, 15, 16, 17 and 19mm. Quick release square drive adaptors - 1/4" SD (x10mm hex); 3/8" SD (x13mm hex); 1/2" SD (x19mm hex). Supplied in a heavy duty fitted storage case.



Metric Ratchet Combination Spanners

Size (mm)	Overall Length	Weight each	Order Code KEN-582	Price/1 TB
10	160mm	58g	-2240K	912.00
11	168mm	80g	-2241K	912.00
12	179mm	90g	-2242K	1007.00
13	180mm	105g	-2243K	1038.00
14	192mm	130g	-2244K	1070.00
15	200mm	152g	-2245K	1101.00
16	215mm	182g	-2246K	1163.00
17	233mm	213g	-2247K	1195.00
18	237mm	230g	-2248K	1384.00
19	249mm	271g	-2249K	1508.00



13
PIECES

Number of Pieces	Weight each	Order Code KEN-582	Price/1 TB
10 Metric	2600g	-2250K	7103.00

HAND TOOLS



KENNEDY PROFESSIONAL Short Arm Ratchet Combination Spanners

Manufactured from quality chrome vanadium steel with hardened jaws and high polish mirror finish, corrosion resistant and easy to clean. Conforms to **ANSI 8107.6**.



Sets

9 Piece Metric:

10, 11, 12, 13, 14, 15, 16, 17 and 19mm.

7 Piece AF:

3/8", 7/16", 1/2", 9/16", 5/8", 11/16" and 3/4".

Metric

Size (mm)	Overall Length	Weight each	Order Code KEN-582	Price/1 TB
10	95	40g	-2188K	472.00
11	100	50g	-2189K	504.00
12	103	55g	-2190K	724.00
13	106	60g	-2191K	787.00
14	114	75g	-2192K	818.00
15	117	90g	-2193K	818.00
16	120	100g	-2194K	818.00
17	127	120g	-2195K	874.00
19	138	155g	-2197K	963.00

AF

Size Inch	Overall Length	Weight each	Order Code KEN-582	Price/1 TB
3/8"	97	45g	-2180K	316.00
7/16"	113	85g	-2181K	377.00
1/2"	108	70g	-2182K	377.00
9/16"	114	85g	-2183K	441.00
5/8"	120	110g	-2184K	504.00
11/16"	127	120g	-2185K	693.00
3/4"	135	155g	-2186K	944.00



Number of Pieces	Weight each	Order Code KEN-582	Price/1 TB
9 Metric	1880g	-2236K	3955.00
7 AF	770g	-2228K	2533.00

Short Arm Combination Spanners

Manufactured from quality chrome vanadium steel with hardened jaws and high polish mirror finish, corrosion-resistant and easy to clean. The jaws and ring are offset at 15° for easier location and application of torque to the fastener. Suitable for use in areas of very restricted access. Conforms to **ASME B107.6**.



WALL DRIVE



Metric

Size (mm)	Overall Length	Weight each	Order Code KEN-582	Price/1 TB
10	97	30g	-2200K	220.00
11	100	40g	-2202K	247.00
12	105	43g	-2204K	274.00
13	110	51g	-2206K	334.00
14	114	65g	-2208K	366.00
15	119	75g	-2210K	377.00
16	124	85g	-2212K	409.00
17	130	95g	-2214K	446.00
18	133	110g	-2216K	446.00
19	140	130g	-2218K	499.00

Set

10 Piece Metric:

10, 11, 12, 13, 14, 15, 16, 17, 18 and 19mm.

**10
PIECES**

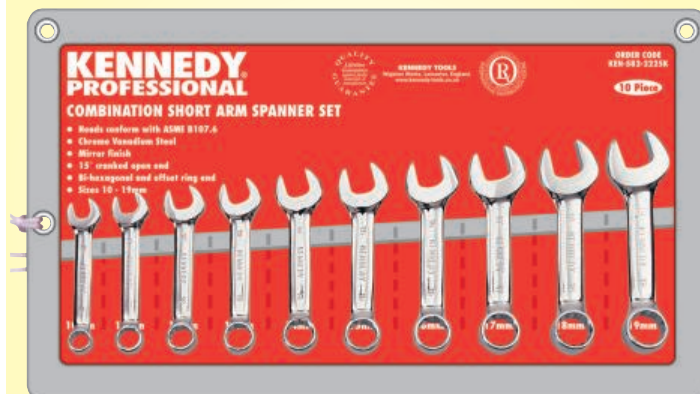

Number of Pieces	Weight each	Order Code KEN-582	Price/1 TB
10 Metric	840g	-2225K	2791.00

GROUP 582 SPANNERS - COMBINATION

Wall Drive Ring End Feature

The wall drive ring end feature has no points on the internal bi-hexagon ring end. This is achieved by a series of radii that gives a wavy look to the internal bi-hexagon ring end.

The internal radii design promotes the use of higher torque loads to be applied to the fastener through increased surface contact areas.

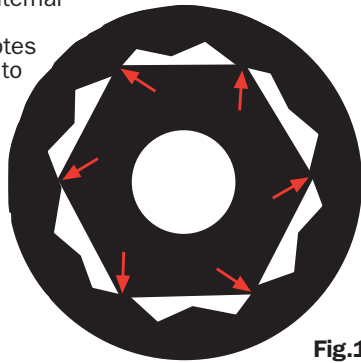

Fig.1

Fig.1 shows the point loads that occur with standard contact wrenches.

Fig.2 shows the increased surface contact area loads of wrenches with wall drive feature.

The increased contact surface area has three main advantages: Helps to reduce stress to the tool, prolonging tool life. Increases the tightening torque transmission force that can be applied to fasteners. Prevents fastener damage, e.g. 'rounding off'.

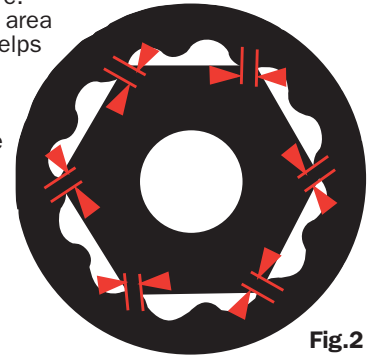

Fig.2

KENNEDY PROFESSIONAL Professional Combination Spanners

Manufactured from chrome vanadium steel with highly polished mirror finish. Mirror finish prevents oil and dirt from adhering to the spanner making for easier cleaning and preventing rust. Long reach, wall drive. Conform with **ASME B107.6**.



HAND TOOLS

Metric				
Size (mm)	Overall Length	Weight each	Order Code KEN-582	Price/1 TB
6	130	26g	-3060K	209.00
7	136	30g	-3070K	222.00
8	148	35g	-3080K	222.00
9	167	53g	-3090K	256.00
10	172	57g	-3100K	288.00
11	186	70g	-3110K	288.00
12	197	80g	-3120K	323.00
13	207	88g	-3130K	323.00
14	223	119g	-3140K	384.00
15	233	133g	-3150K	436.00
16	243	145g	-3160K	436.00
17	261	179g	-3170K	498.00
18	270	199g	-3180K	552.00
19	280	220g	-3190K	552.00
20	290	323g	-3200K	683.00
21	301	323g	-3210K	683.00
22	318	361g	-3220K	703.00
23	325	400g	-3225K	773.00
24	338	443g	-3230K	778.00
25	350	540g	-3231K	912.00
26	350	525g	-3232K	1056.00
27	370	610g	-3233K	1182.00
28	370	585g	-3234K	1258.00
29	400	715g	-3235K	1321.00
30	400	735g	-3236K	1508.00
32	430	915g	-3237K	1572.00

AF				
Size (AF)	Overall Length	Weight each	Order Code KEN-582	Price/1 TB
11/32"	143	32g	-3239K	317.00
1/4"	130	26g	-3240K	213.00
5/16"	148	35g	-3250K	220.00
3/8"	167	53g	-3260K	254.00
7/16"	186	70g	-3270K	288.00
1/2"	207	88g	-3280K	323.00
9/16"	223	119g	-3290K	381.00
5/8"	243	145g	-3300K	438.00
11/16"	261	179g	-3310K	498.00
3/4"	280	220g	-3320K	554.00
13/16"	297	296g	-3330K	649.00
7/8"	320	350g	-3340K	707.00
15/16"	340	435g	-3350K	805.00
1"	355	510g	-3360K	905.00

Sets

14 Piece Metric: 6, 7, 8, 9, 10, 11, 12, 13, 14, 15, 16, 17, 18 and 19mm.

14* Piece Metric: 6, 8, 9, 10, 13, 14, 15, 17, 19, 22, 24, 27, 30 and 32mm.

18 Piece Metric: 6, 7, 8, 9, 10, 11, 12, 13, 14, 15, 16, 17, 18, 19, 20, 21, 22, and 24mm.

26 Piece Metric: 6, 7, 8, 9, 10, 11, 12, 13, 14, 15, 16, 17, 18, 19, 20, 21, 22, 23, 24, 25, 26, 27, 28, 29, 30 and 32mm.

9 Piece AF: 1/4", 5/16", 3/8", 7/16", 1/2", 9/16", 5/8", 11/16" and 3/4".

13 Piece AF: 1/4", 5/16", 3/8", 7/16", 1/2", 9/16", 5/8", 11/16", 3/4", 13/16", 7/8", 15/16" and 1".

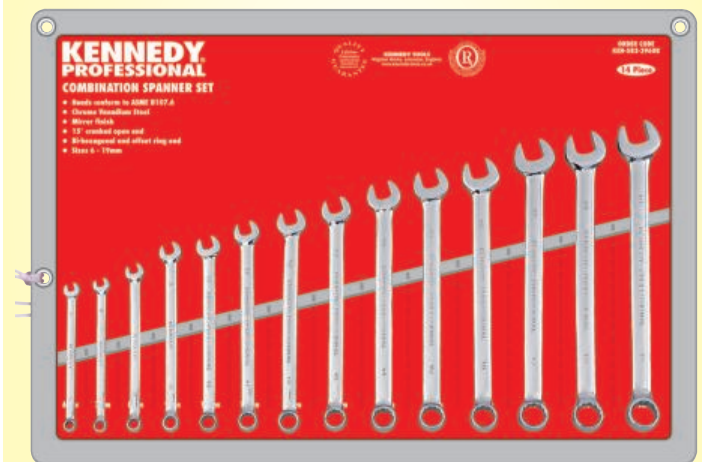

Number of Pieces	Weight each	Order Code KEN-582	Price/1 TB
14 Metric	1.65kg	-3960K	4939.00
14* Metric	4.60kg	-3972K	6792.00
18 Metric	2.85kg	-3970K	7077.00
26 Metric	8.90kg	-3974K	11944.00
9 AF	1.00kg	-3920K	3272.00
13 AF	1.95kg	-3930K	6771.00

KENNEDY Industrial
QUALITY INDUSTRIAL TOOLING
Combination Spanners



Manufactured from chrome vanadium steel with a satin finish body and highly polished heads. 15° open jaw angle to shank and ring end offset. Conform to: 5.5mm - 25mm, 1/4" - 1" AF - **DIN 3113**. 26mm - 95mm, 1 1/16" - 2" AF - **ASME B107.6**. 1/8" - 1/2" Whitworth - **DIN 3113 & BS192:1982**. 9/16" - 7/8" Whitworth - **ASME B107.6 & BS192:1982**.

Metric

Size (mm)	Overall Length	Weight each	Order Code KEN-582	Price/1 TB
5.5	93	10g	-2560K	167.00
6	100	14g	-2570K	110.00
7	110	18g	-2580K	110.00
8	120	27g	-2590K	120.00
9	130	33g	-2600K	125.00
10	140	36g	-2610K	130.00
11	150	47g	-2630K	142.00
12	160	55g	-2640K	160.00
13	170	66g	-2660K	168.00
14	180	82g	-2670K	190.00
15	190	90g	-2680K	206.00
16	200	107g	-2690K	239.00
17	210	130g	-2700K	255.00
18	220	138g	-2710K	281.00
19	230	159g	-2720K	300.00
20	240	185g	-2730K	351.00
21	250	193g	-2740K	366.00
22	260	225g	-2750K	393.00
23	260	265g	-2760K	424.00
24	280	294g	-2770K	486.00
25	295	330g	-2780K	501.00
26	295	435g	-2790K	509.00
27	310	387g	-2800K	611.00
28	340	675g	-2810K	663.00
29	340	1280g	-2850K	628.00
30	340	675g	-2820K	712.00
32	360	485g	-2830K	805.00
36	410	600g	-2840K	1075.00
38	430	1280g	-2860K	1391.00
41	460	1800g	-2870K	1515.00
46	500	1900g	-2880K	2575.00
50	540	2350g	-2890K	3147.00
55	560	3085g	-2891K	3605.00
60	600	3750g	-2892K	5665.00
65	675	5700g	-2893K	7957.00
70	675	5400g	-2894K	10079.00
75	720	5700g	-2895K	11140.00
80	720	6500g	-2896K	21909.00
85	730	6800g	-2897K	30767.00
90	730	7000g	-2898K	31827.00
95	750	7200g	-2899K	32942.00

Manufactured from chrome vanadium steel (except * which is made from drop forged carbon steel) with a satin finish body and highly polished heads.



AF

Size (AF)	Overall Length	Weight each	Order Code KEN-582	Price/1 TB
1/4"	100	14g	-2260K	93.00
5/16"	120	27g	-2270K	95.00
3/8"	140	33g	-2280K	116.00
7/16"	150	47g	-2290K	137.00
1/2"	170	66g	-2300K	162.00
9/16"	180	82g	-2310K	204.00
5/8"	200	107g	-2320K	215.00
11/16"	210	138g	-2340K	250.00
3/4"	230	159g	-2350K	272.00
7/8"	260	225g	-2360K	328.00
13/16"	250	268g	-2370K	328.00
15/16"	280	294g	-2380K	458.00
1"	295	330g	-2390K	618.00
1 1/16"*	358	540g	-2400K	777.00
1 1/8"*	380	675g	-2410K	536.00
1 1/4"*	418	820g	-2420K	654.00
1 5/16"*	461	972g	-2430K	824.00
1 3/8"*	461	972g	-2440K	886.00
1 7/16"*	486	1280g	-2450K	949.00
1 1/2"*	486	1280g	-2460K	1085.00
1 5/8"*	540	1800g	-2470K	1391.00
1 3/4"*	611	1900g	-2480K	1515.00
1 7/8"*	611	2350g	-2490K	1751.00
2"*	611	2350g	-2500K	1829.00

Sets

Number of Pieces	Weight each	Order Code KEN-582	Price/1 TB
11 Metric	2.60kg	-2980K	10661.00
14 Metric	3.10kg	-2900K	6917.00
14* Metric	1.20kg	-2960K	2479.00
18 Metric	2.20kg	-2970K	4105.00
26 Metric	5.75kg	-2910K	8299.00
9 AF	0.80kg	-2920K	1618.00
11 AF	2.65kg	-2940K	10558.00
12 AF	1.80kg	-2930K	3019.00
7 Whitworth	0.95kg	-2950K	1430.00

Whitworth

Size Whit	Overall Length	Weight each	Order Code KEN-582	Price/1 TB
1/8"	140	30g	-3370K	136.00
3/16"	160	50g	-3380K	149.00
1/4"	180	65g	-3390K	180.00
5/16"	200	97g	-3400K	222.00
3/8"	220	150g	-3410K	190.00
7/16"	250	200g	-3420K	209.00
1/2"	280	228g	-3430K	346.00
9/16"*	332	430g	-3440K	361.00
5/8"*	380	690g	-3450K	441.00
11/16"*	418	885g	-3460K	428.00
3/4"*	461	850g	-3470K	721.00
7/8"*	486	930g	-3480K	799.00

Sets:

11 Piece: 26, 27, 28, 29, 30, 32, 36, 38, 41, 46 and 50mm
14 Piece: 6, 8, 9, 10, 13, 14, 15, 17, 19, 22, 24, 27, 30 and 32mm.
14* Piece: 6, 7, 8, 9, 10, 11, 12, 13, 14, 15, 16, 17, 18 and 19mm.
18 Piece: 6, 7, 8, 9, 10, 11, 12, 13, 14, 15, 16, 17, 18, 19, 20, 21, 22 and 24mm.
26 Piece: 6, 7, 8, 9, 10, 11, 12, 13, 14, 15, 16, 17, 18, 19, 20, 21, 22, 23, 24, 25, 26, 27, 28, 29, 30 and 32mm.
9 Piece AF: 1/4", 5/16", 3/8", 7/16", 1/2", 9/16", 5/8", 11/16" and 3/4"
11 Piece AF: *1 1/16", *1 1/8", *1 1/4", *1 5/16", *1 3/8", *1 7/16", *1 1/2", *1 5/8", *1 3/4", *1 7/8" and *2"
12 Piece: 1/4", 5/16", 3/8", 7/16", 1/2", 9/16", 5/8", 11/16", 3/4", 7/8", 15/16" and 1".
7 Piece Whitworth: 1/8", 3/16", 1/4", 5/16", 3/8", 7/16" and 1/2".

HAND TOOLS

Industrial Offset Combination Spanners

Chrome vanadium steel. 15° cranked open end. Offset ring end. Up to 25% longer than conventional **DIN 3113** combination spanners. Conform to **DIN 3113B**.



Metric

Size (mm)	Overall Length	Weight each	Order Code KEN-582	Price/1 TB
6	127	20g	-3880K	195.00
7	135	25g	-3881K	221.00
8	145	35g	-3882K	239.00
9	155	40g	-3883K	246.00
10	167	50g	-3884K	252.00
11	173	55g	-3885K	315.00
12	180	65g	-3886K	315.00
13	195	80g	-3887K	339.00
14	210	95g	-3888K	376.00
15	215	110g	-3889K	384.00
16	230	135g	-3890K	415.00
17	240	160g	-3891K	541.00
18	255	170g	-3892K	573.00
19	265	190g	-3893K	628.00
21	280	240g	-3894K	703.00
22	300	275g	-3895K	824.00
24	320	350g	-3896K	879.00
27	340	565g	-3897K	1577.00
30	360	665g	-3878K	1905.00
32	380	821g	-3879K	2224.00

Set

14 Piece Metric: 6, 7, 8, 9, 10, 11, 12, 13, 14, 15, 16, 17, 18, and 19mm.

14 PIECES

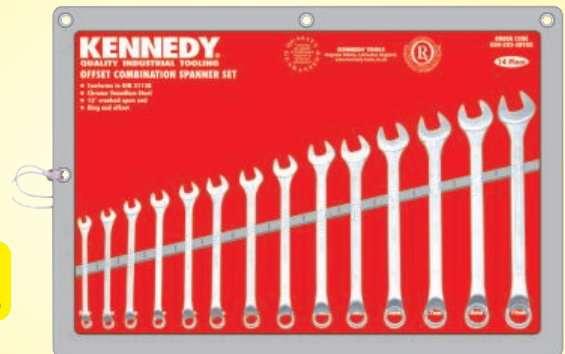

No. of Pieces	Weight each	Order Code KEN-582	Price/1 TB
14 Metric	1.50kg	-3898K	6541.00

GROUP 582 SPANNERS - COMBINATION

YAMOTO Industrial Combination Spanners

Made from fully polished chrome vanadium steel with a 15° offset. Conform to **DIN 3113**.

NEW



Size (mm)	Overall Length	Weight each	Order Code YMT-582	Price/1 TB
6	100	14g	-3060K	42.00
7	110	18g	-3070K	42.00
8	120	27g	-3080K	57.00
9	130	33g	-3090K	61.00
10	140	36g	-3100K	67.00
11	150	47g	-3110K	73.00
12	160	55g	-3120K	78.00
13	170	66g	-3130K	83.00
14	180	82g	-3140K	88.00
15	190	90g	-3150K	93.00
16	200	107g	-3160K	109.00
17	210	130g	-3170K	114.00
18	220	138g	-3180K	119.00

Size (mm)	Overall Length	Weight each	Order Code YMT-582	Price/1 TB
19	230	159g	-3190K	132.00
20	240	185g	-3200K	146.00
21	250	193g	-3210K	151.00
22	260	225g	-3220K	181.00
23	260	265g	-3225K	186.00
24	280	294g	-3230K	213.00
25	295	330g	-3231K	227.00
26	295	435g	-3232K	294.00
27	310	387g	-3233K	308.00
28	340	675g	-3234K	335.00
30	340	675g	-3236K	351.00
32	360	485g	-3237K	361.00

Sets

14 Piece: 6, 7, 8, 9, 10, 11, 12, 13, 14, 15, 16, 17, 18 and 19mm.

25 Piece: 6, 7, 8, 9, 10, 11, 12, 13, 14, 15, 16, 17, 18, 19, 20, 21, 22, 23, 24, 25, 26, 27, 28, 30 and 32mm.



Number of Pieces	Weight each	Order Code YMT-582	Price/1 TB
14 Metric	3.10kg	-3960K	1236.00
25 Metric	5.75kg	-3974K	3605.00

SENATOR QUALITY TOOLING Combination Spanners

Manufactured from forged chrome vanadium steel with satin finish and 15° cranked heads. Conform to **DIN 3113**.

NEW



Size (mm)	Overall Length	Weight each	Order Code SEN-582	Price/1 TB
6	100	14g	-4100K	31.00
7	110	18g	-4110K	31.00
8	120	27g	-4120K	42.00
9	130	33g	-4130K	44.00
10	140	36g	-4140K	47.00
11	150	47g	-4150K	51.00
12	160	55g	-4160K	55.00
13	170	66g	-4170K	61.00
14	180	82g	-4180K	64.00
15	190	90g	-4190K	72.00
16	200	107g	-4200K	82.00
17	210	130g	-4210K	83.00
18	220	138g	-4220K	93.00

Size (mm)	Overall Length	Weight each	Order Code SEN-582	Price/1 TB
19	230	159g	-4230K	102.00
20	240	185g	-4240K	113.00
21	250	193g	-4250K	117.00
22	260	225g	-4260K	140.00
23	260	265g	-4270K	144.00
24	280	294g	-4280K	164.00
25	295	330g	-4290K	175.00
26	295	435g	-4300K	226.00
27	310	387g	-4310K	237.00
28	340	675g	-4320K	258.00
30	340	675g	-4330K	270.00
32	360	485g	-4340K	340.00

Sets

14 Piece: 6, 7, 8, 9, 10, 11, 12, 13, 14, 15, 16, 17, 18 and 19mm.

25 Piece: 6, 7, 8, 9, 10, 11, 12, 13, 14, 15, 16, 17, 18, 19, 20, 21, 22, 23, 24, 25, 26, 27, 28, 30 and 32mm.



Number of Pieces	Weight each	Order Code SEN-582	Price/1 TB
14 Metric	3.10kg	-4510K	1029.00
25 Metric	5.75kg	-4600K	2318.00

KENNEDY PROFESSIONAL E-Torx® Ring Spanners

Manufactured from drop forged chrome vanadium steel. Polished finish. Set is supplied in wallet with hanging holes.

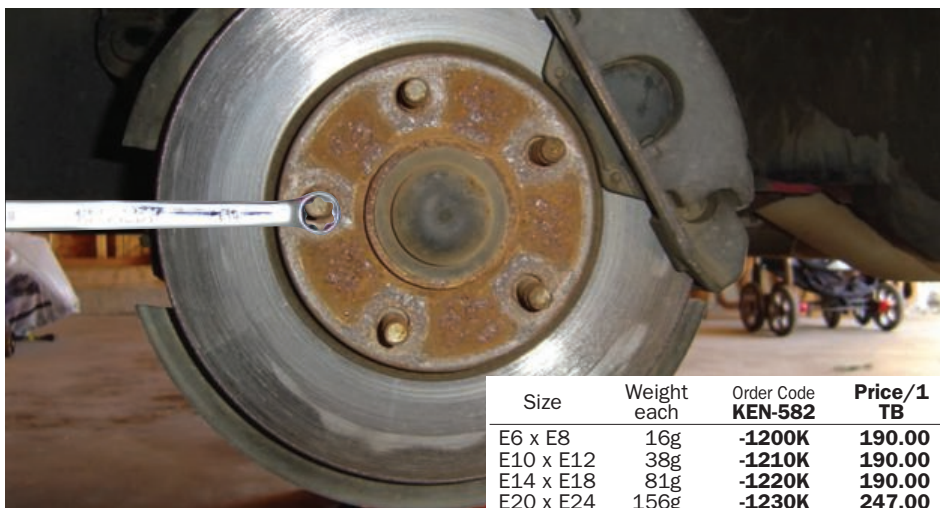

Size	Weight each	Order Code KEN-582	Price/1 TB
E6 x E8	16g	-1200K	190.00
E10 x E12	38g	-1210K	190.00
E14 x E18	81g	-1220K	190.00
E20 x E24	156g	-1230K	247.00

Sets

4 Piece E-Torx:

E6 x E8, E10 x E12, E14 x E18 and E20 x E24mm

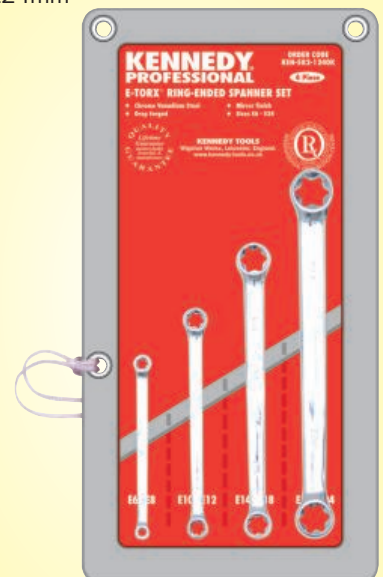

Number of Pieces	Weight each	Order Code KEN-582	Price/1 TB
4	440g	-1240K	823.00

HAND TOOLS

KENNEDY PROFESSIONAL 12-In-1 Reversible Ratchet Spanners



Double ended ratchet spanners with 12 sizes each. These spanners fit mm, inch and E-TORX fasteners saving space and weight in the toolbox. The 72 teeth lever ratcheting system requires only 5 degree movement to operate making them ideal for use in tight areas. Made from high quality chrome vanadium steel with mirror polish finish to prevent oil and dirt from adhering to the spanner.



Sizes (Per Spanner):

8, 10, 11 & 13mm/ $5/16"$ $3/8"$ $7/16"$ & $1/2"$ /E10, E12, E14 & E16
14, 16, 17 & 19mm/ $9/16"$ $5/8"$ $11/16"$ $3/4"$ /E18, E20, E22 & E24

Metric	Size Range (mm)	Overall Length	Weight each	Order Code KEN-582	Price/1 TB
	8 - 13	160	97g	-6862K	1482.00
	14 - 19	230	263g	-6864K	1701.00

2 Piece Set: One of each as above



Number of Pieces	Weight each	Order Code KEN-582	Price/1 TB
2 Pieces	380g	-6870K	2684.00

4-In-1 Reversible Ratchet Spanners

Double ended ratchet spanners with 4 sizes each, saving space and weight in the toolbox. 72 teeth lever ratcheting system that requires only 5° movement to operate, making them ideal for use in tight areas. Made from high quality chrome vanadium steel with mirror polish finish to prevent oil and dirt from adhering to the spanner.



Metric	Size Range (mm)	Overall Length	Weight each	Order Code KEN-582	Price/1 TB
	8 - 13	160	97g	-6852K	1154.00
	9 - 15	180	125g	-6854K	1263.00
	16 - 19	230	263g	-6856K	1427.00

3 Piece Set

The most commonly used 12 sizes in just three spanners, 8 - 19mm. Supplied with storage roll.
Sizes (per spanner):
8, 10, 12 & 13mm.
9, 11, 14 & 15mm.
16, 17, 18 & 19mm.



Number of Pieces	Weight each	Order Code KEN-582	Price/1 TB
3 Metric	510g	-6860K	3012.00

KENNEDY QUALITY INDUSTRIAL TOOLING Reversible Ratchet Ring Wrenches



For use where access is limited. With a built-in ratchet mechanism to provide speed and a reversible action which can be achieved by depressing the reversing lever or by simply turning the wrench over. All ratcheting ring wrenches are manufactured from chrome vanadium steel bi-hex rings.

Straight



Metric	Size (mm)	Overall Length	Weight each	Order Code KEN-582	*Single hexagon Price/1 TB
	6* x 7*	115	65g	-9720K	979.00
	8 x 9	135	80g	-9721K	1021.00
	10 x 11	140	90g	-9722K	1087.00
	12 x 13	175	170g	-9723K	1584.00
	14 x 15	210	270g	-9724K	1620.00
	17 x 19	210	260g	-9725K	1843.00
	21 x 22	240	305g	-9726K	1885.00

AF

Size (AF)	Weight each	Order Code KEN-582	Price/1 TB
$1/4"$ * x $5/16"$	60g	-9732K	698.00
$3/8"$ x $7/16"$	90g	-9733K	717.00
$1/2"$ x $9/16"$	160g	-9734K	793.00
$5/8"$ x $11/16"$	270g	-9735K	824.00
$3/4"$ x $7/8"$	305g	-9736K	886.00

Sets

7 Piece Metric: 6 x 7, 8 x 9, 10 x 11, 12 x 13, 14 x 15, 17 x 19 and 21 x 22mm

5 Piece AF: $1/4"$ x $5/16"$, $3/8"$ x $7/16"$, $1/2"$ x $9/16"$, $5/8"$ x $11/16"$ and $3/4"$ x $7/8"$



Number of Pieces	Weight each	Order Code KEN-582	Price/1 TB
7 Metric	1300g	-9730K	10597.00
5 AF	930g	-9740K	2897.00

25° Offset



Metric	Size (mm)	Overall Length	Weight each	Order Code KEN-582	*Single hexagon Price/1 TB
	6* x 7*	115	65g	-9742K	698.00
	8 x 9	135	80g	-9743K	698.00
	10 x 11	140	90g	-9744K	1000.00
	12 x 13	175	165g	-9745K	1961.00
	14 x 15	210	260g	-9746K	1620.00
	17 x 19	205	250g	-9747K	1843.00
	21 x 22	235	310g	-9748K	1885.00

AF

Size (AF)	Weight each	Order Code KEN-582	Price/1 TB
$1/4"$ * x $5/16"$	60g	-9752K	979.00
$3/8"$ x $7/16"$	90g	-9753K	1087.00
$1/2"$ x $9/16"$	170g	-9754K	1620.00
$5/8"$ x $11/16"$	265g	-9755K	1843.00
$3/4"$ x $7/8"$	300g	-9756K	1826.00

Sets Contents:

7 Piece Metric: 6 x 7, 8 x 9, 10 x 11, 12 x 13, 14 x 15, 17 x 19 and 21 x 22mm.

5 Piece AF: $1/4"$ x $5/16"$, $3/8"$ x $7/16"$, $1/2"$ x $9/16"$, $5/8"$ x $11/16"$ and $3/4"$ x $7/8"$.

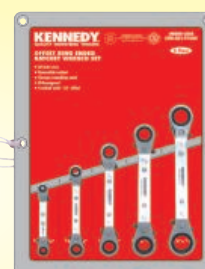

Number of Pieces	Weight each	Order Code KEN-582	Price/1 TB
7 Metric	1280g	-9750K	10597.00
5 AF	930g	-9760K	7990.00

GROUP 582 SPANNERS - RING

KENNEDY Double Ended Ring Spanners
QUALITY INDUSTRIAL TOOLING



Made from chrome vanadium steel with a satin finish body and highly polished heads, with double ended closed jaw bi-hexagon offset. Conform to **DIN 838 Metric & AF, BS 192 : 1982 & BS 3555 : 1998 Whitworth**.



Metric	Size (mm)	Overall Length	Weight each	Order Code KEN-582	Price/1 TB
6 x 7	180	40g	-1570K	176.00	
8 x 9	190	60g	-1590K	197.00	
8 x 10	200	60g	-1600K	197.00	
10 x 11	205	87g	-1610K	247.00	
10 x 13	220	120g	-1620K	247.00	
12 x 13	220	120g	-1640K	274.00	
13 x 17	270	190g	-1660K	306.00	
14 x 15	235	152g	-1670K	306.00	
16 x 17	250	186g	-1680K	351.00	
17 x 19	270	240g	-1690K	416.00	
18 x 19	270	240g	-1700K	416.00	
19 x 22	290	350g	-1710K	428.00	
19 x 24	330	380g	-1720K	428.00	
20 x 22	290	320g	-1730K	471.00	
21 x 23	315	400g	-1740K	525.00	
22 x 24	330	368g	-1750K	525.00	
24 x 26	335	465g	-1760K	603.00	
24 x 27	340	465g	-1770K	603.00	
24 x 30	362	495g	-1780K	603.00	
25 x 28	360	545g	-1790K	657.00	
27 x 30	380	638g	-1800K	733.00	
30 x 32	380	638g	-1810K	799.00	
30 x 36	420	820g	-1820K	1465.00	
32 x 36	420	900g	-1830K	1465.00	
36 x 41	430	1100g	-1840K	1902.00	
41 x 46	440	1300g	-1850K	4119.00	
46 x 50	505	1570g	-1860K	5562.00	

AF	Size AF	Weight each	Order Code KEN-582	Price/1 TB
1/4" x 5/16"	60g	-1260K	176.00	
5/16" x 3/8"	75g	-1270K	187.00	
3/8" x 7/16"	94g	-1280K	247.00	
7/16" x 1/2"	124g	-1290K	247.00	
1/2" x 9/16"	152g	-1300K	274.00	
9/16" x 5/8"	157g	-1310K	351.00	
5/8" x 11/16"	218g	-1320K	351.00	
11/16" x 3/4"	250g	-1340K	416.00	
3/4" x 7/8"	320g	-1350K	428.00	
13/16" x 7/8"	335g	-1360K	471.00	
15/16" x 1"	465g	-1380K	603.00	
11/16" x 1 1/4"	618g	-1410K	733.00	

Ring Crescent Wrenches

Chrome vanadium steel with satin chrome finish. Heads conform to **DIN 838**.



Size (mm)	Overall Length	Weight each	Order Code KEN-582	Price/1 TB
10 x 11	142	71g	-3766K	824.00
12 x 13	164	100g	-3768K	1006.00
14 x 15	189	157g	-3770K	1238.00
17 x 19	219	172g	-3772K	1515.00

Whitworth

Size Whitworth	Weight each	Order Code KEN-582	Price/1 TB
3/16" x 1/4"	110g	-2010K	205.00
1/4" x 5/16"	150g	-2020K	258.00
5/16" x 3/8"	200g	-2030K	306.00
7/16" x 1/2"	354g	-2050K	366.00
9/16" x 5/8"	490g	-2070K	691.00
11/16" x 3/4"	660g	-2100K	1029.00

Sets

7 Piece Metric: 6 x 7, 8 x 9, 10 x 11, 12 x 13, 14 x 15, 16 x 17 and 18 x 19mm.

11 Piece Metric: 6 x 7, 8 x 9, 10 x 11, 12 x 13, 14 x 15, 16 x 17, 18 x 19, 20 x 22, 21 x 23, 24 x 27 and 30 x 32mm.

5 Piece AF: 1/4" x 5/16", 3/8" x 7/16", 1/2" x 9/16", 5/8" x 11/16" and 3/4" x 7/8".

10 Piece AF: 1/4" x 5/16", 5/16" x 3/8", 3/8" x 7/16", 7/16" x 1/2", 1/2" x 9/16", 9/16" x 5/8", 5/8" x 11/16", 11/16" x 3/4", 3/4" x 7/8" and 15/16" x 1".

5 Piece BSW: 3/16" x 1/4", 5/16" x 3/8", 7/16" x 1/2", 9/16" x 5/8" and 11/16" x 3/4" BSW.



No. of Pieces	Weight each	Order Code KEN-582	Price/1 TB
7 Metric	1.20kg	-1960K	2677.00
11 Metric	1.90kg	-1970K	5738.00
5 AF	0.92kg	-1920K	1592.00
10 AF	2.00kg	-1930K	6544.00
5 BSW	2.75kg	-1950K	3354.00

Ring Crescent Wrench Sets

4 Piece Metric: - 10 - 19mm

10 x 11mm,
12 x 13mm,
14 x 15mm,
17 x 19mm.



Range (mm)	Weight each	Order Code KEN-582	Price/1 TB
10 - 19	540g	-3776K	4595.00

HAND TOOLS



KENNEDY PROFESSIONAL Professional Flared Nut Ring Spanners

Conform to: **ASME B107.4**. Made from chrome vanadium steel with a highly polished mirror finish. Made to American Federal Standards, giving higher torque therefore improved performance. The wrench will fit over the pipe to give a positive location on the nut. Can be used on hydraulic pipes, brake pipes etc.



Metric Conform with ANSI B107.9M.

Size (mm)	Overall Length	Weight each	Order Code KEN-582	Price/1 TB
8 x 10	145	45g	-1020K	137.00
9 x 11	145	45g	-1030K	154.00
12 x 14	175	90g	-1040K	197.00
13 x 15	170	90g	-1050K	197.00
16 x 17	200	130g	-1060K	318.00



AF Conform with ANSI B107.6

Size (AF)	Overall Length	Weight each	Order Code KEN-582	Price/1 TB
5/16" x 3/8"	145	45g	-1110K	197.00
3/8" x 7/16"	155	60g	-1120K	324.00
1/2" x 9/16"	175	90g	-1130K	328.00
5/8" x 11/16"	198	130g	-1140K	384.00

Set

5 Piece Metric: 8 x 10, 9 x 11, 12 x 14, 13 x 15 and 16 x 17mm.

4 Piece AF: 5/16" x 3/8", 3/8" x 7/16", 1/2" x 9/16" and 5/8" x 11/16".



Number of Pieces	Weight each	Order Code KEN-582	Price/1 TB
5 Metric	420g	-1090K	984.00
4 AF	270g	-1170K	1040.00

KENNEDY QUALITY INDUSTRIAL TOOLING Industrial Flared Nut Ring Spanners

Conform to **ASME B107.4**. Made from high quality chrome vanadium steel. Satin finish body with highly polished heads. Offset ends. The wrench will fit over the pipe to give a positive location on the nut. Can be used on hydraulic pipes, brake pipes etc.



Metric Conform with ANSI B107.9M.

Size (mm)	Overall Length	Weight each	Order Code KEN-582	Price/1 TB
6 x 8	135	38g	-3490K	144.00
8 x 10	135	38g	-3500K	170.00
9 x 11	155	54g	-3510K	185.00
10 x 11	155	54g	-3520K	201.00
10 x 12	155	54g	-3530K	213.00
12 x 14	175	95g	-3540K	239.00
13 x 14	175	95g	-3550K	255.00
14 x 17	200	130g	-3590K	280.00
17 x 19	200	130g	-3600K	296.00
19 x 22	225	220g	-3610K	351.00
22 x 24	230	270g	-3620K	375.00
24 x 27	250	340g	-3630K	440.00
30 x 32	275	450g	-3640K	567.00

Set

6 Piece Metric:

6 x 8, 9 x 11, 10 x 12, 13 x 14, 14 x 17 and 19 x 22mm.

5 Piece AF:

1/4" x 5/16", 3/8" x 7/16", 1/2" x 9/16", 5/8" x 11/16" and 3/4" x 7/8".



Number of Pieces	Weight each	Order Code KEN-582	Price/1 TB
6 Metric	710g	-3650K	1370.00
5 AF	620g	-3659K	876.00

PRODUCTS ARE ONLY AVAILABLE VIA YOUR DISTRIBUTOR

GROUP 582 SPANNERS - OPEN ENDED

KENNEDY Industrial
QUALITY INDUSTRIAL TOOLING *Open Ended Spanners*



Chrome vanadium steel (except * which are made from drop forged carbon steel) with a satin finish body and highly polished heads, with a 15° offset.

DIN 3110: 4 x 5mm to 32 x 36mm, 1/4" x 5/16" to 1 5/16" x 1 5/8" AF.

ASME B107.39: 36 x 41mm to 46 x 50mm, 1 7/16" x 1 5/8" to 1 13/16" x 2" AF.

DIN 3110 & BS192:1982: 1/8" x 3/16" to 1" x 1 1/8" Whitworth.



HAND TOOLS

Metric	Size (mm)	Overall Length	Weight each	Order Code KEN-582	Price/1 TB
	4 x 5	103	12g	-0530K	165.00
	5 x 5.5	103	15g	-0540K	165.00
	5.5 x 7	122	25g	-0550K	137.00
	6 x 7	122	25g	-0570K	144.00
	7 x 8	122	25g	-0580K	149.00
	8 x 9	140	32g	-0590K	149.00
	8 x 10	140	32g	-0600K	154.00
	10 x 11	156	48g	-0610K	176.00
	10 x 12	156	48g	-0612K	182.00
	10 x 13	172	63g	-0620K	187.00
	11 x 13	172	63g	-0630K	192.00
	12 x 13	172	63g	-0640K	197.00
	12 x 14	172	63g	-0644K	219.00
	13 x 15	186	100g	-0650K	268.00
	13 x 17	188	96g	-0660K	274.00
	14 x 15	188	96g	-0670K	280.00
	14 x 17	188	96g	-0677K	280.00
	16 x 17	204	120g	-0680K	280.00
	17 x 19	220	171g	-0690K	280.00
	18 x 19	220	171g	-0700K	318.00
	19 x 21	234	198g	-0709K	384.00
	19 x 22	234	198g	-0710K	395.00
	19 x 24	234	198g	-0720K	410.00
	20 x 22	234	198g	-0730K	416.00
	21 x 23	247	200g	-0740K	433.00
	22 x 24	247	200g	-0750K	438.00
	24 x 26	266	311g	-0760K	493.00
	24 x 27	266	311g	-0770K	499.00
	24 x 30	285	405g	-0780K	499.00
	25 x 28	285	405g	-0790K	504.00
	30 x 32	302	460g	-0810K	608.00
	27 x 30	302	460g	-0820K	641.00
	27 x 32	302	460g	-0830K	646.00
	30 x 36	319	692g	-0840K	874.00
	32 x 36	319	692g	-0850K	931.00
	*36 x 41	434	1340g	-0860K	1422.00
	*41 x 46	465	1782g	-0870K	1914.00
	*46 x 50	495	2368g	-0880K	2185.00

AF	Size AF	Weight each	Order Code KEN-582	Price/1 TB
	1/4" x 5/16"	25g	-0260K	121.00
	5/16" x 3/8"	32g	-0270K	121.00
	3/8" x 7/16"	48g	-0280K	165.00
	7/16" x 1/2"	63g	-0290K	165.00
	1/2" x 9/16"	80g	-0300K	174.00
	9/16" x 5/8"	96g	-0310K	246.00
	5/8" x 1 1/16"	120g	-0320K	246.00
	5/8" x 3/4"	170g	-0330K	246.00
	1 1/16" x 3/4"	171g	-0340K	255.00
	3/4" x 7/8"	198g	-0350K	333.00
	13/16" x 7/8"	220g	-0360K	341.00
	7/8" x 1 5/16"	260g	-0370K	382.00
	1 5/16" x 1"	311g	-0380K	428.00
	1" x 1 1/8"	405g	-0400K	438.00
	1 1/16" x 1 1/4"	460g	-0410K	454.00
	1 1/8" x 1 5/16"	460g	-0420K	580.00
	1 3/16" x 1 5/16"	460g	-0430K	608.00
	1 1/4" x 1 3/8"	692g	-0450K	823.00
	1 5/16" x 1 1/2"	692g	-0460K	876.00
	*1 7/16" x 1 5/8"	1340g	-0470K	1288.00
	*1 1/2" x 1 5/8"	1340g	-0480K	1545.00
	*1 11/16" x 1 7/8"	1782g	-0490K	1751.00
	*1 13/16" x 2"	2368g	-0510K	2059.00

Whitworth	Size Whitworth	Weight each	Order Code KEN-582	Price/1 TB
	1/8" x 3/16"	55g	-0010K	308.00
	3/16" x 1/4"	70g	-0020K	308.00
	1/4" x 5/16"	90g	-0030K	160.00
	5/16" x 3/8"	120g	-0040K	214.00
	3/8" x 7/16"	225g	-0050K	226.00
	7/16" x 1/2"	230g	-0060K	232.00
	1/2" x 9/16"	325g	-0070K	306.00
	9/16" x 5/8"	385g	-0090K	1029.00
	9/16" x 1 1/16"	435g	-0100K	1029.00
	5/8" x 1 1/16"	490g	-0110K	1082.00
	5/8" x 3/4"	495g	-0120K	1133.00
	1 1/16" x 3/4"	495g	-0130K	1236.00
	3/4" x 7/8"	740g	-0140K	1339.00

Sets:

7 Piece Metric: 6 x 7, 8 x 9, 10 x 11, 12 x 13, 14 x 15, 16 x 17 and 18 x 19mm.

8 Piece Metric: 24 x 26, 25 x 28, 27 x 30, 27 x 32, 32 x 36, *36 x 41, *41 x 46 and *46 x 50mm.

11 Piece Metric: 6 x 7, 8 x 9, 10 x 11, 12 x 13, 14 x 15, 16 x 17, 18 x 19, 20 x 22, 21 x 23, 24 x 27 and 30 x 32mm.

5 Piece AF: 1/4" x 5/16", 3/8" x 7/16", 1/2" x 9/16", 5/8" x 1 1/16" and 3/4" x 7/8".

10 Piece AF: 1/4" x 5/16", 5/16" x 3/8", 3/8" x 7/16", 7/16" x 1/2", 1/2" x 9/16", 9/16" x 5/8", 5/8" x 1 1/16", 1 1/16" x 3/4", 3/4" x 7/8" and 1 5/16" x 1".

8 Piece Whitworth: 1/8" x 3/16", 3/16" x 1/4", 1/4" x 5/16", 5/16" x 3/8", 3/8" x 7/16", 7/16" x 1/2", 1/2" x 9/16" and 9/16" x 5/8".

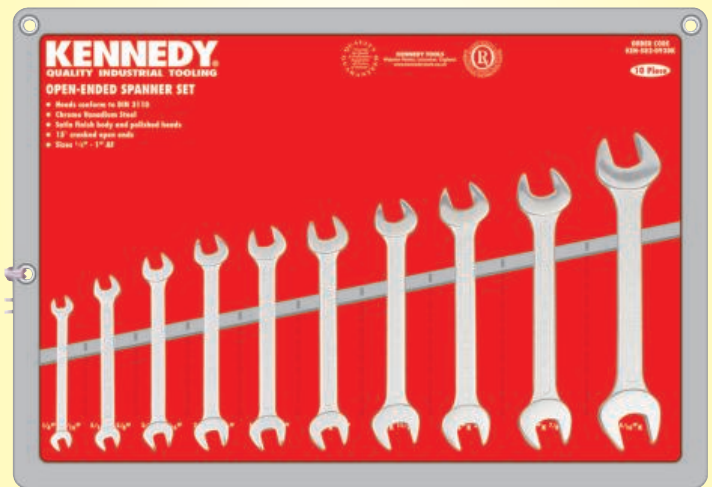

Number of Pieces	Weight each	Order Code KEN-582	Price/1 TB
7 Metric	0.64kg	-0960K	1526.00
8 Metric	7.70kg	-0990K	8196.00
11 Metric	1.90kg	-0970K	3335.00
5 AF	0.55kg	-0920K	1092.00
10 AF	1.20kg	-0930K	2678.00
8 Whit	1.50kg	-0950K	2788.00

KENNEDY PROFESSIONAL Professional Open Ended Spanners

Chrome vanadium steel with a highly polished mirror finish preventing oil and dirt from adhering to the spanner. Made to American Federal Standards, extra thick heads offer higher torque forces to be applied therefore improved performance. Conform to **ASME B107.39**



Metric

Size (mm)	Overall Length	Weight each	Order Code KEN-582	Price/1 TB	Size (mm)	Overall Length	Weight each	Order Code KEN-582	Price/1 TB
6 x 7	126	25g	-2990K	225.00	18 x 19	230	210g	-3050K	537.00
8 x 9	135	45g	-3000K	240.00	20 x 22	250	280g	-3051K	575.00
10 x 11	146	55g	-3010K	301.00	21 x 23	250	290g	-3052K	641.00
12 x 13	165	90g	-3020K	339.00	24 x 27	290	400g	-3053K	705.00
14 x 15	185	120g	-3030K	410.00	30 x 32	360	750g	-3054K	827.00
16 x 17	185	138g	-3040K	466.00					

Sets

7 Piece Metric:
6 x 7, 8 x 9, 10 x 11, 12 x 13, 14 x 15, 16 x 17 and 18 x 19mm.

11 Piece Metric:
6 x 7, 8 x 9, 10 x 11, 12 x 13, 14 x 15, 16 x 17, 18 x 19, 20 x 22, 21 x 23, 24 x 27 & 30 x 32mm.



Number of Pieces	Weight each	Order Code KEN-582	Price/1 TB
7 Metric	780g	-3900K	2325.00
11 Metric	2730g	-3910K	4091.00

YAMOTO Industrial Open Ended Spanners

Made from chrome vanadium steel with polished head and 15° offset. Conform to **DIN 3110**

NEW



Metric

Size (mm)	Overall Length	Weight each	Order Code YMT-582	Price/1 TB	Size (mm)	Overall Length	Weight each	Order Code YMT-582	Price/1 TB
6 x 7	122	25g	-2990K	47.00	18 x 19	220	171g	-3050K	155.00
8 x 9	140	32g	-3000K	67.00	20 x 22	234	198g	-3051K	212.00
10 x 11	156	48g	-3010K	88.00	21 x 23	247	200g	-3052K	222.00
12 x 13	172	63g	-3020K	98.00	24 x 27	266	311g	-3053K	356.00
14 x 15	188	96g	-3030K	109.00	30 x 32	302	460g	-3054K	407.00
16 x 17	204	120g	-3040K	129.00					

Sets

7 Piece Metric:
6 x 7, 8 x 9, 10 x 11, 12 x 13, 14 x 15, 16 x 17 and 18 x 19mm.

11 Piece Metric:
6 x 7, 8 x 9, 10 x 11, 12 x 13, 14 x 15, 16 x 17, 18 x 19, 20 x 22, 21 x 23, 24 x 27 & 30 x 32mm.



Number of Pieces	Weight each	Order Code YMT-582	Price/1 TB
7 Metric	780g	-3930K	1200.00
11 Metric	2730g	-3910K	1803.00

SENATOR QUALITY TOOLING Open Ended Spanners

Drop forged steel with 15° cranked open ends. Satin finish heads. Conform to **DIN 3110**

NEW



Metric

Size (mm)	Overall Length	Weight each	Order Code SEN-582	Price/1 TB	Size (mm)	Overall Length	Weight each	Order Code SEN-582	Price/1 TB
6 x 7	122	25g	-4700K	37.00	18 x 19	220	171g	-4760K	109.00
8 x 9	140	32g	-4710K	47.00	20 x 22	234	198g	-4770K	145.00
10 x 11	156	48g	-4720K	52.00	21 x 23	247	200g	-4780K	150.00
12 x 13	172	63g	-4730K	62.00	24 x 27	266	311g	-4790K	243.00
14 x 15	188	96g	-4740K	78.00	30 x 32	302	460g	-4800K	308.00
16 x 17	204	120g	-4750K	88.00					

Sets

7 Piece Metric:
6 x 7, 8 x 9, 10 x 11, 12 x 13, 14 x 15, 16 x 17 and 18 x 19mm.

11 Piece Metric:
6 x 7, 8 x 9, 10 x 11, 12 x 13, 14 x 15, 16 x 17, 18 x 19, 20 x 22, 21 x 23, 24 x 27 & 30 x 32mm.



Number of Pieces	Weight each	Order Code SEN-582	Price/1 TB
7 Metric	780g	-4830K	799.00
11 Metric	2730g	-4850K	1236.00

PRODUCTS ARE ONLY AVAILABLE VIA YOUR DISTRIBUTOR



Metric. Conform to **BS 192 : 1982 & DIN 3110.**

Size (mm)	Overall Length	Weight each	Order Code KEN-582	Price/1 TB
3.2 x 4.0	70	6g	-1001K	137.00
0.4 x 5.0	70	6g	-1002K	137.00
0.5 x 5.5	80	11g	-1003K	149.00
5.5 x 6.0	80	11g	-1004K	165.00
0.6 x 7.0	80	10g	-1005K	187.00
0.7 x 8.0	90	15g	-1006K	197.00

BA. Conform to **BS 1842 : 1952.**

Size (BA)	Overall Length	Weight each	Order Code KEN-582	Price/1 TB
0 x 2	89	25g	-0190K	102.00
1 x 3	67	20g	-0200K	102.00
4 x 6	63	10g	-0220K	102.00
5 x 7	63	5g	-0230K	102.00
8 x 10	64	5g	-0240K	109.00
9 x 11	51	5g	-0250K	111.00

Set
6 Piece BA: 0 x 2, 1 x 3, 4 x 6, 5 x 7, 8 x 10, 9 x 11BA.
6 Piece Metric: 3.2 x 4, 4 x 5, 5 x 5.5, 5.5 x 6, 6 x 7, 7 x 8mm



6 PIECES

Number of Pieces	Weight each	Order Code KEN-582	Price/1 TB
6 BA	90g	-0910K	712.00
6 Metric	90g	-1010K	1017.00

Crowfoot Wrenches

3/8 Chrome vanadium wrenches designed to be used for getting into tight spots and hard to reach areas, in particular around tubing such as hydraulic lines etc. For use with 3/8" square drive tools.

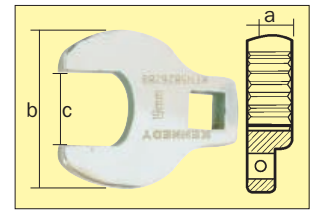

(c)	Size (mm) (b)	(a)	Weight each	Order Code KEN-582	Price/1 TB
10	22	9	20g	-6280K	338.00
11	25	9	25g	-6281K	307.00
12	28	9	33g	-6282K	307.00
13	28	9	33g	-6283K	307.00
14	33	9	37g	-6284K	307.00
15	33	9	46g	-6285K	324.00
17	38	9	60g	-6287K	324.00
19	43	10	72g	-6289K	324.00
22	47	10	94g	-6292K	324.00
24	53	10	117g	-6294K	324.00

Set
10 Piece Metric:

10, 11, 12, 13, 14, 15, 17, 19, 22 and 24mm. Supplied on a sliding socket rail for storage.

10 PIECES

Number of Pieces	Weight each	Order Code KEN-582	Price/1 TB
10 Metric	610g	-6300K	2774.00

Flexi-ring End Sockets

1/2 Made from polished chrome vanadium. These tough flexi-ring end sockets are designed to allow access over long studs and for awkwardly positioned nuts and bolts. Swivels through 220°.

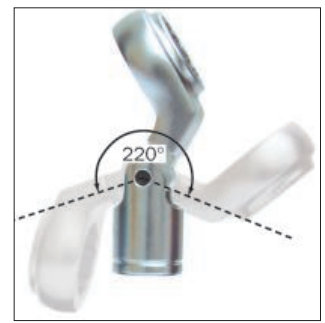

Type	Size	Overall Length	Weight each	Order Code KEN-582	Price/1 TB
Metric	13mm	70mm	124g	-1180K	274.00
	14mm	70mm	123g	-1181K	301.00
	15mm	70mm	121g	-1182K	313.00
	16mm	70mm	119g	-1183K	313.00
	17mm	77mm	158g	-1184K	339.00
	19mm	77mm	152g	-1185K	339.00
	22mm	82mm	193g	-1186K	357.00
	24mm	86mm	213g	-1187K	384.00

8 Piece Metric Set Contents:
 13, 14, 15, 16, 17, 19, 22, and 24mm.
 Supplied with a sturdy hanging rail.

8 PIECES



Number of Pieces	Contents	Weight each	Order Code KEN-582	Price/1 TB
8	As above	1.3kg	-1190K	2733.00



KENNEDY PROFESSIONAL Swivel End Socket Wrenches

Designed to give greater flexibility and improved access when working in difficult conditions. Bi-hexagon (12 point). Manufactured from fully polished chrome vanadium steel. Conform with **ANSI B107.5M**.



Set
6 Piece Bi-hexagon:
8 x 9,
10 x 11,
12 x 13,
14 x 15,
16 x 17 and
18 x 19mm.

6
PIECES



Size (mm)	Overall Length	Weight each	Order Code KEN-582	Price/1 TB
8 x 9	175	135g	-3670K	315.00
10 x 11	185	135g	-3680K	423.00
12 x 13	196	150g	-3690K	428.00
14 x 15	220	200g	-3700K	542.00
16 x 17	240	245g	-3710K	572.00
18 x 19	265	295g	-3720K	582.00

Number of Pieces	Weight each	Order Code KEN-582	Price/1 TB
6	1.40kg	-3725K	2627.00

11 Piece Ignition Wrench Set

Contents:
8 open end spanners 4 - 7.5mm x 0.5mm increments, screwdriver, file, 0.40mm gap gauge.



11
PIECES

Number of Pieces	Contents	Weight each	Order Code KEN-582	Price/1 TB
11	As above	440g	-3780K	577.00

Adjustable 'C' Hook Spanners

Manufactured from chrome vanadium steel with a highly polished chrome plated finish.

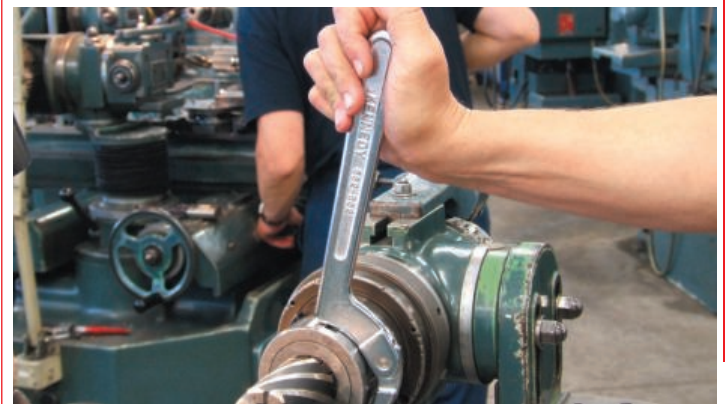

Diameter	Weight each	Order Code KEN-582	Price/1 TB
3/4 - 2"	120g	-9600K	1048.00
1 1/4 - 3"	250g	-9610K	1436.00
2 - 4 3/4"	460g	-9620K	1861.00

Strap & Chain Wrenches

Used for gripping round any irregular shaped items, tubes and piping. Ideal for oil filters, hot radiator caps and hub caps. Both types suitable for 60 - 140mm diameters.

Strap Type: Hardened chrome vanadium handle with industrial strength, rubber strap that will not mark or scratch workpieces.

Chain Type: Hardened chrome vanadium handle with heavy duty chain for a positive grip.

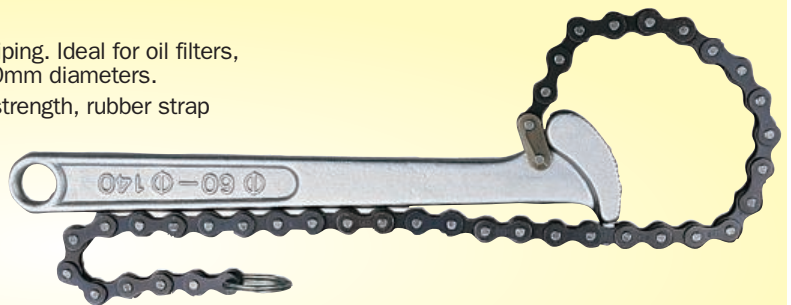
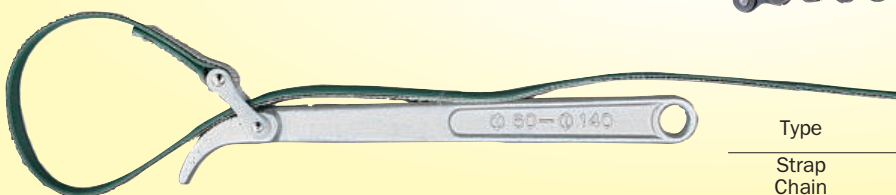

Type	Weight each	Order Code KEN-582	Price/1 TB
Strap	280g	-9500K	901.00
Chain	430g	-9520K	901.00

PRODUCTS ARE ONLY AVAILABLE VIA YOUR DISTRIBUTOR

HAND TOOLS

KENNEDY PROFESSIONAL Side Drive Sockets

The Ken-Grip® socket offers a new standard of performance with the ability to grip fasteners which are up to 95% rounded off. A unique patented socket design grips new, worn and rusted fasteners without damaging them further. Double knurl feature gives a high grip which is essential for quick tool change when hands are greasy or oily. Manufactured from chrome vanadium steel, the sockets and accessories are aluminium free, fully chrome plated for a corrosion resistant, easy clean finish. The set features an extensive selection of socket sizes for use across a wide range of fasteners.

KENGRIP®

Patented Design



Will grip new, worn and rusted fasteners without damaging them further



Will grip fasteners which are up to 95% rounded off

Will also fit a wide range of non-metric Hexagons, E-Torx® and Spline Drive Sizes.

Standard Length Sockets

Conform to DIN3124.



1/4" Square Drive

Size	Overall Length	Weight each	Order Code KEN-582	Price/1 TB
4.0mm	25.0	10g	-4161K	81.00
4.5mm	25.0	10g	-4162K	81.00
5.0mm	25.0	10g	-4163K	81.00
5.5mm	25.0	10g	-4164K	81.00
6.0mm	25.0	10g	-4165K	81.00
7.0mm	25.0	20g	-4166K	81.00
8.0mm	25.0	20g	-4167K	81.00
9.0mm	25.0	20g	-4168K	81.00
10.0mm	25.0	20g	-4169K	81.00
11.0mm	25.0	30g	-4170K	81.00
12.0mm	25.0	30g	-4171K	91.00
13.0mm	25.0	30g	-4172K	101.00
14.0mm	25.0	40g	-4173K	113.00

Standard Length Sockets

Conform to DIN3124.

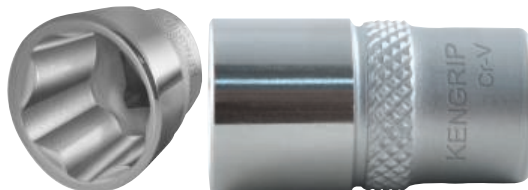

3/8" Square Drive

Size	Overall Length	Weight each	Order Code KEN-582	Price/1 TB
6.0mm	26.0	30g	-5832K	88.00
7.0mm	26.0	30g	-5833K	88.00
8.0mm	26.0	30g	-5834K	88.00
9.0mm	26.0	30g	-5835K	88.00
10.0mm	26.0	30g	-5836K	88.00
11.0mm	26.0	30g	-5837K	129.00
12.0mm	26.0	30g	-5838K	140.00
13.0mm	26.0	30g	-5839K	140.00
14.0mm	30.0	40g	-5840K	140.00
15.0mm	30.0	40g	-5841K	140.00
16.0mm	30.0	50g	-5842K	150.00
17.0mm	30.0	60g	-5843K	155.00
18.0mm	30.0	70g	-5844K	155.00
19.0mm	30.0	70g	-5845K	155.00
20.0mm	30.0	80g	-5846K	160.00
21.0mm	30.0	80g	-5847K	160.00
22.0mm	27.0	100g	-5848K	160.00

Standard Length Sockets

Conform to DIN3124.



1/2" Square Drive

Size	Overall Length	Weight each	Order Code KEN-582	Price/1 TB
8.0mm	36.0	50g	-6871K	198.00
9.0mm	37.0	50g	-6872K	198.00
10.0mm	37.0	50g	-6873K	198.00
11.0mm	37.0	50g	-6874K	198.00
12.0mm	37.0	50g	-6875K	198.00
13.0mm	37.0	50g	-6876K	198.00
14.0mm	37.0	50g	-6877K	198.00
15.0mm	37.0	60g	-6878K	222.00
16.0mm	37.0	60g	-6879K	222.00
17.0mm	37.0	60g	-6880K	222.00
18.0mm	37.0	80g	-6881K	232.00
19.0mm	37.0	70g	-6882K	232.00
20.0mm	37.0	80g	-6883K	308.00
21.0mm	37.0	70g	-6884K	308.00
22.0mm	37.0	90g	-6885K	308.00
23.0mm	37.0	110g	-6886K	308.00
24.0mm	37.0	110g	-6887K	361.00
25.0mm	40.0	150g	-6888K	387.00
26.0mm	40.0	140g	-6889K	397.00
27.0mm	40.0	170g	-6890K	411.00
28.0mm	40.0	170g	-6891K	411.00
29.0mm	40.0	170g	-6892K	412.00
30.0mm	45.0	210g	-6893K	428.00
32.0mm	45.0	230g	-6895K	438.00
33.0mm	45.0	230g	-6898K	593.00
36.0mm	45.0	245g	-6899K	747.00

Deep Sockets

Conform to DIN3124.



3/8" Square Drive

Size	Overall Length	Weight each	Order Code KEN-582	Price/1 TB
8.0mm	62.0	40g	-5849K	181.00
9.0mm	62.0	40g	-5850K	181.00
10.0mm	62.0	50g	-5851K	181.00
11.0mm	62.0	50g	-5852K	181.00
12.0mm	62.0	60g	-5853K	191.00
13.0mm	62.0	60g	-5854K	191.00
14.0mm	62.0	70g	-5855K	191.00
15.0mm	62.0	100g	-5856K	191.00
16.0mm	62.0	115g	-5857K	191.00
17.0mm	62.0	130g	-5858K	191.00
18.0mm	64.0	120g	-5859K	201.00
19.0mm	64.0	140g	-5860K	232.00
21.0mm	64.0	155g	-5861K	243.00
22.0mm	64.0	200g	-5862K	258.00

HAND TOOLS

KENNEDY PROFESSIONAL Side Drive Socket Sets



1/4" Square Drive 19 Piece Metric Set

Metric Ken-Grip® Sockets: 4, 4.5, 5, 5.5, 6, 7, 8, 9, 10, 11, 12, 13, 14mm.

Accessories: ratchet handle, spinner handle, sliding T-handle, flexi-drive 145mm, universal joint, extension bar 100mm.

**19
PIECES**

Number of Pieces	Weight each	Order Code	Price/1 TB
19	880g	-8800K	6896.00



3/8" Square Drive 50 Piece Metric Set

Ken-Grip® Standard & Deep Sockets
Standard: 6, 7, 8, 9, 10, 11, 12, 13, 14, 15, 16, 17, 18, 19, 20, 21 and 22mm.
Deep: 10, 11, 12, 13, 14, 15, 17, 19 and 22mm.

Screwdriver Bits: Slotted 5, 5.5 and 6.5mm.

Crosspoint No.1, 2, 3, 4.

Sockets: 3, 4, 5, 6, 8 and 10mm.

Accessories: ratchet handle, sliding T-handle, spinner handle, swivel handle, universal joint, 125 and 250mm extensions, 250mm wobble extensions, 1/4" and 1/2" male adaptors, 1/4" socket bit coupler. Robust fitted case with security padlock hole and cushion grip handle.

**50
PIECES**

Number of Pieces	Weight each	Order Code	Price/1 TB
50	3.00kg	-8810K	11618.00



1/2" Square Drive 30 Piece Metric Set

Ken-Grip®: 8, 9, 10, 11, 12, 13, 14, 15, 16, 17, 18, 19, 20, 21, 22, 23, 24, 25, 26, 27, 30 and 32mm.

Spark Plug Sockets: M10 and M14.

Accessories: quick release ratchet handle, sliding T-handle, universal joint, 75, 125 and 250mm extension bars. Robust fitted case with security padlock hole and cushion grip handle.

**30
PIECES**

Number of Pieces	Weight each	Order Code	Price/1 TB
30	5.50kg	-8820K	10079.00



HAND TOOLS

KENNEDY PROFESSIONAL Push Through Steel Handles



1/4 Chrome - molybdenum with mirror polished finish. Push through square drive, needs only 3% movement to operate ratchet.



Type	Overall Length	Weight each	Order Code KEN-582	Price/1 TB
Standard	125mm	120g	-4025K	1577.00
Stubby	75mm	70g	-4028K	1700.00

Disc Type Steel Handle

1/4 Standard wrench with high polished finish. Fitted with spring loaded ball bearing socket retainer. Manufactured from chrome vanadium steel.



Overall Length	Number of Teeth	Weight each	Order Code KEN-582	Price/1 TB
140	20	170g	-4020K	886.00

Lever Reversible Rubber Handle

1/4 Chrome vanadium. Rubber grip, 72 tooth ratchet. With thumb lever for reversing without having to remove the socket or accessory. With quick release. A high quality wrench for the professional user.



Overall Length	Number of Teeth	Weight each	Order Code KEN-582	Price/1 TB
140mm	72	90g	-4005K	2331.00

Lever Reversible Steel Handle

1/4 Fully chromed all steel handle with thumb lever for reversing without having to remove the socket or accessory.



Overall Length	Number of Teeth	Weight each	Order Code KEN-582	Price/1 TB
143mm	72	120g	-4015K	2457.00

Spinner Handles

1/4 **Fixed Type:** Chrome vanadium blade with spring loaded ball bearing socket retainer. **Overall length:** 150mm.



Handle Type	Weight each	Order Code KEN-582	Price/1 TB
Bi-Material	110g	-4190K	559.00
Polypropelene	110g	-4200K	340.00

Extension Bars

1/4 Manufactured from high quality chrome vanadium with a fully polished finish. All with knurled 'finger grip'.

Standard



Overall Length	Weight each	Order Code KEN-582	Price/1 TB
50mm	25g	-4060K	131.00
100mm	50g	-4080K	137.00
150mm	70g	-4100K	146.00
250mm	115g	-4120K	322.00

Flexible

Steel wire braid allows access into obstructed areas.

Overall Length	Weight each	Order Code KEN-582	Price/1 TB
150mm	150g	-4140K	270.00

Wobble

In areas where clearance may be a problem the 'wobble' square drive can be used at an angle of up to 15°.



Overall Length	Weight each	Order Code KEN-582	Price/1 TB
50mm	25g	-4070K	146.00
100mm	50g	-4090K	163.00
150mm	70g	-4110K	189.00
250mm	115g	-4130K	239.00

SENATOR QUALITY TOOLING Lever Reversible Rubber Handle



1/4 40 tooth chrome vanadium quick release ratchet with rubber grip, thumb lever for reversing without having to remove the socket or accessory.



Overall Length	Number of Teeth	Weight each	Order Code SEN-582	Price/1 TB
145	40	120g	-4000K	284.00

KENNEDY PROFESSIONAL Ratchet Repair Kits



To suit Ratchet Number	Weight each	Order Code KEN-582	Price/1 TB
KEN-582-4020K	30g	-4280K	376.00
KEN-582-4005K/4015K	30g	-4290K	572.00

Swivel Handle

1/4 The hinged link allows operation at varied angles to aid access in restricted areas. Knurled grip.



Overall Length	Weight each	Order Code KEN-582	Price/1 TB
150mm	125g	-4180K	376.00

KENNEDY PROFESSIONAL Sliding 'T' Handle

1/4 Manufactured from high quality chrome vanadium with a fully polished finish. The sliding bar will give many options for leverage within a given space.



Overall Length	Weight each	Order Code KEN-582	Price/1 TB
105mm	50g	-4040K	176.00

SOCKETS & ACCESSORIES - 1/4" SQUARE DRIVE

KENNEDY PROFESSIONAL Bi-Hexagon Sockets

1/4" Ideal for assembly and servicing of small precision mechanisms associated with electrical, electronic, ignition and refrigeration work. All bi-hexagon unless stated.

1/4" Double knurl feature gives a high grip which is essential for a quick tool change when your hands are greasy/oily. The 12 point bi-hexagon side drive design will give a higher torque than normal sockets. Manufactured from chrome vanadium, fully chrome plated with a mirror finish and aluminium-free to ensure non-sparking. Chamfered leading edge ensures easy fastener location.

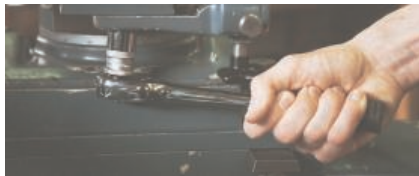

Size (mm)	Overall Length	Weight each	Order Code KEN-582	Price/1 TB
Metric				
4.0	25mm	10g	-4300K	57.00
4.5	25mm	10g	-4310K	57.00
5.0	25mm	10g	-4320K	57.00
5.5	25mm	10g	-4330K	57.00
6.0	25mm	10g	-4340K	57.00
7.0	25mm	20g	-4350K	57.00
8.0	25mm	20g	-4360K	57.00
9.0	25mm	20g	-4370K	57.00
10.0	25mm	20g	-4380K	57.00
11.0	25mm	30g	-4390K	57.00
12.0	25mm	30g	-4400K	58.00
13.0	25mm	30g	-4410K	58.00
14.0	25mm	40g	-4420K	59.00

Size (mm)	Overall Length	Weight each	Order Code KEN-582	Price/1 TB
Metric (Single Hex)				
4.0	25mm	10g	-4540K	40.00
5.0	25mm	10g	-4542K	40.00
5.5	25mm	10g	-4543K	40.00
6.0	25mm	10g	-4544K	40.00
7.0	25mm	20g	-4545K	40.00
8.0	25mm	20g	-4546K	40.00
9.0	25mm	20g	-4547K	42.00
10.0	25mm	20g	-4548K	42.00
11.0	25mm	30g	-4549K	42.00
12.0	25mm	30g	-4550K	42.00
13.0	25mm	30g	-4551K	45.00
14.0	25mm	40g	-4552K	50.00

Size (mm)	Overall Length	Weight each	Order Code KEN-582	Price/1 TB
Metric (Deep)				
4.0	50mm	10g	-4670K	61.00
4.5	50mm	10g	-4671K	83.00
5.0	50mm	10g	-4672K	84.00
5.5	50mm	10g	-4673K	84.00
6.0	50mm	10g	-4674K	84.00
7.0	50mm	20g	-4675K	84.00
8.0	50mm	20g	-4676K	84.00
9.0	50mm	20g	-4677K	84.00
10.0	50mm	20g	-4678K	84.00
11.0	50mm	30g	-4679K	84.00
12.0	50mm	30g	-4680K	84.00
13.0	50mm	30g	-4681K	84.00
14.0	50mm	40g	-4682K	84.00

Size (mm)	Overall Length	Weight each	Order Code KEN-582	Price/1 TB
Metric (Single Hex Deep)				
6.0	50mm	10g	-4566K	73.00
7.0	50mm	10g	-4567K	73.00
8.0	50mm	10g	-4568K	73.00
9.5	50mm	10g	-4569K	73.00
10.0	50mm	10g	-4570K	73.00
11.0	50mm	20g	-4571K	83.00
12.0	50mm	20g	-4572K	83.00
13.0	50mm	20g	-4573K	83.00
14.0	50mm	40g	-4574K	94.00

Universal Joint

1/4" Hinged through 180° in both directions. Knurled for extra grip.

Drive male x female: 1/4" x 1/4".



Overall Length	Weight each	Order Code KEN-582	Price/1 TB
40mm	30g	-4160K	200.00

Size (mm)	Overall Length	Weight each	Order Code KEN-582	Price/1 TB
AF				
3/16"	25mm	10g	-4450K	75.00
7/32"	25mm	10g	-4460K	75.00
1/4"	25mm	10g	-4470K	75.00
9/32"	25mm	20g	-4480K	75.00
5/16"	25mm	20g	-4490K	75.00
11/32"	25mm	20g	-4500K	75.00
3/8"	25mm	30g	-4510K	95.00
7/16"	25mm	30g	-4520K	95.00
1/2"	25mm	30g	-4530K	95.00
9/16"	25mm	30g	-4532K	139.00

Size (mm)	Overall Length	Weight each	Order Code KEN-582	Price/1 TB
AF (Single Hex)				
3/16"	25mm	10g	-4430K	63.00
7/32"	25mm	10g	-4431K	63.00
1/4"	25mm	10g	-4432K	63.00
9/32"	25mm	20g	-4433K	63.00
5/16"	25mm	20g	-4434K	63.00
11/32"	25mm	20g	-4435K	63.00
3/8"	25mm	30g	-4436K	63.00
7/16"	25mm	30g	-4437K	63.00
1/2"	25mm	30g	-4438K	63.00
9/16"	25mm	30g	-4439K	75.00

Size (mm)	Overall Length	Weight each	Order Code KEN-582	Price/1 TB
AF (Deep)				
3/16"	50mm	10g	-4580K	105.00
7/32"	50mm	10g	-4581K	105.00
1/4"	50mm	10g	-4582K	105.00
9/32"	50mm	10g	-4583K	105.00
5/16"	50mm	10g	-4584K	105.00
11/32"	50mm	20g	-4585K	105.00
3/8"	50mm	20g	-4586K	116.00
7/16"	50mm	30g	-4588K	121.00
1/2"	50mm	50g	-4590K	126.00
9/16"	50mm	40g	-4592K	137.00

Size (mm)	Overall Length	Weight each	Order Code KEN-582	Price/1 TB
AF (Single Hex Deep)				
3/16"	50mm	10g	-4555K	61.00
7/32"	50mm	10g	-4556K	61.00
1/4"	50mm	10g	-4557K	61.00
9/32"	50mm	10g	-4558K	61.00
5/16"	50mm	10g	-4559K	61.00
11/32"	50mm	20g	-4560K	61.00
3/8"	50mm	20g	-4561K	66.00
7/16"	50mm	30g	-4562K	73.00
1/2"	50mm	50g	-4563K	78.00
9/16"	50mm	40g	-4564K	83.00

Size (mm)	Overall Length	Weight each	Order Code KEN-582	Price/1 TB
*Single Hex BA				
0	25mm	30g	-4600K	61.00
*1	25mm	30g	-4610K	61.00
2	25mm	20g	-4620K	61.00
3	25mm	20g	-4630K	61.00
4	25mm	20g	-4640K	61.00
*5	25mm	10g	-4650K	61.00
*6	25mm	10g	-4660K	61.00

Adaptors/Converters

1/4" Chrome vanadium.

Hex Bit Adaptor

Converts square drive tooling to use hexagon bits.



Square Drive x Hex	Overall Length	Weight each	Order Code KEN-582	Price/1 TB
1/4" x 1/4"	25mm		-4230K	151.00

Screwdriver Bits

1/4" Manufactured from high quality chrome vanadium, fully polished finish. Conform to DIN.

Overall length: 37mm.

Bit length: 19mm.



Type	Size (mm)	Order Code KEN-582	Price/1 TB
Slotted ⊖	4.0mm	-4700K	123.00
	5.5mm	-4710K	123.00
	7.0mm	-4730K	123.00
Cross Point ⊕	No.1	-4750K	123.00
	No.2	-4760K	123.00
	No.3	-4770K	123.00
	No.4	-4780K	123.00
Hexagon ⊙	3.0mm	-4790K	123.00
	4.0mm	-4800K	123.00
	5.0mm	-4810K	123.00
	6.0mm	-4820K	123.00
	8.0mm	-4830K	123.00
	1/8"	-4840K	66.00
	5/32"	-4850K	66.00
	3/16"	-4860K	66.00
	7/32"	-4870K	66.00
	1/4"	-4880K	83.00
	5/16"	-4890K	88.00
Torx ⊗	T6	-4685K	83.00
	T7	-4686K	83.00
	T8	-4687K	83.00
	T9	-4688K	83.00
	T10	-4689K	83.00
	T15	-4690K	83.00
	T20	-4691K	83.00
	T25	-4692K	83.00
	T27	-4693K	94.00
	T30	-4694K	105.00
T40	-4695K	116.00	

Double Ended Lug

For connecting two female square drives



Drive Female x Male	Overall Length	Weight each	Order Code KEN-582	Price/1 TB
1/4" x 1/4"	25mm		-4240K	114.00

Drive Converter

For using a combination of square drive sockets in one application.

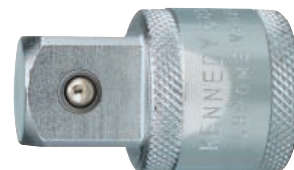

Drive Female x Male	Overall Length	Weight each	Order Code KEN-582	Price/1 TB
1/4" x 3/8"	27mm		-4220K	98.00
3/8" x 1/4"	37mm		-5180K	97.00

HAND TOOLS

GROUP 582 SOCKETS & ACCESSORIES - 3/8" SQUARE DRIVE

SENATOR *Lever Reversible Rubber Handle*

3/8 With thumb lever for reversing without having to remove the socket or accessory. Highly polished chrome vanadium with rubber grip.



Overall Length	Number of Teeth	Weight each	Order Code	Price/1 TB
200mm	40	345g	SEN-582	320.00

KENNEDY *Disc Type Steel Handle*

3/8 Basic wrench with high polished finish. Fitted with spring loaded ball bearing socket retainer.



Overall Length	Number of Teeth	Weight each	Order Code	Price/1 TB
200mm	42	380g	KEN-582	541.00

Lever Reversible Rubber Handle

3/8 Chrome vanadium. Rubber grip, 72 tooth ratchet. With thumb lever for reversing without having to remove the socket or accessory. With quick release. A high quality wrench for the professional user.



Overall Length	Number of Teeth	Weight each	Order Code	Price/1 TB
200mm	72	215g	KEN-582	2080.00

KENNEDY *Swivel Handles*

3/8 The hinged link allows operation at varied angles to aid access in restricted areas.



Grip	Overall Length	Weight each	Order Code	Price/1 TB
Steel	225mm	310g	-5060K	458.00
Rubber	225mm	225g	-5160K	464.00

Heavy Duty American Pattern



Grip	Overall Length	Weight each	Order Code	Price/1 TB
American	225mm	310g	-5065K	666.00
Components				
Replacement Knuckle			-5068K	365.00

YAMOTO *Quick Release Ratchet Handle*

3/8 With thumb lever for reversing without having to remove the socket or accessory. Highly polished chrome vanadium with rubber grip.



Overall Length	Number of Teeth	Weight each	Order Code	Price/1 TB
200mm	72	345g	YMT-582	1698.00

Push Through Rubber Handle

3/8 A very economic wrench with a one way ratchet. Push through square drive allows left and right hand operation.



Overall Length	Number of Teeth	Weight each	Order Code	Price/1 TB
200mm	41	205g	KEN-582	3166.00

Clutch Type Drive Push Through Steel Handles

3/8 Chrome - molybdenum with mirror polished finish. Clutch type drive action Push through square drive, needs only 3% movement to operate ratchet.

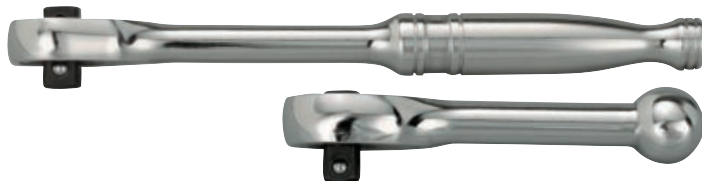

Type	Overall Length	Weight each	Order Code	Price/1 TB
Standard	180mm	220g	KEN-582	1685.00
Stubby	105mm	120g	-4948K	1700.00

Lever Reversible Steel Handle

3/8 Fully chromed all steel handle with thumb lever for reversing without having to remove the socket or accessory.



Overall Length	Number of Teeth	Weight each	Order Code	Price/1 TB
200mm	72	205g	KEN-582	2080.00

Ratchet Repair Kits

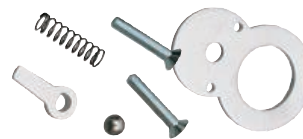

To suit Ratchet Number	Weight each	Order Code	Price/1 TB
KEN-582-4900K	70g	-5220K	617.00
KEN-582-4932/4942K	70g	-5215K	582.00
KEN-582-4940K	70g	-5235K	582.00

YAMOTO *Swivel Handle*

3/8 Chrome finish. American style handle.



Overall Length	Weight each	Order Code	Price/1 TB
225mm	310g	YMT-582	441.00

HAND TOOLS

KENNEDY PROFESSIONAL Extension Bars



3/8 Extensions
Manufactured from high quality chrome vanadium with a fully polished finish. All with knurled 'finger grip'.



Standard

Overall Length	Weight each	Order Code KEN-582	Price/1 TB
75mm	80g	-4960K	155.00
125mm	130g	-4980K	163.00
150mm	150g	-5000K	204.00
250mm	280g	-5020K	307.00
300mm	340g	-5050K	360.00
450mm	430g	-5070K	698.00

Locking
A lever at the ratchet end of the extension pushes down a rod inside the bar which locks out the socket retaining ball, securing the socket to the bar. Ideal for use where there is a risk of leaving a socket in a recess.

Overall Length	Weight each	Order Code KEN-582	Price/1 TB
300mm	15g	-5150K	698.00

Wobble
In areas where clearance may be a problem the 'wobble' square drive can be used at an angle of up to 15°.

Overall Length	Weight each	Order Code KEN-582	Price/1 TB
75mm	65g	-5110K	185.00
150mm	120g	-5120K	246.00
250mm	260g	-5140K	411.00

YAMOTO Composite Ratchet Handle

3/8 With reverse lever, push button quick release. Offset handle to help eliminate knuckle scrapes. 72-tooth gear drive for maximum power and chrome vanadium core for strength.



Overall Length	Number of Teeth	Weight each	Order Code YMT-582	Price/1 TB
200mm	72	235g	-7510K	1476.00

Extensions

3/8 Chrome finish.



Type	Overall Length (mm)	Weight each	Order Code YMT-582	Price/1 TB
Standard	75	75g	-4960K	83.00
Standard	150	145g	-5000K	95.00
Wobble	250	235g	-5140K	316.00

Spinner Handle Fixed Type

3/8

Overall Length	Weight each	Order Code YMT-582	Price/1 TB
150mm	240g	-5100K	222.00

Sliding 'T' Handle

3/8

Overall Length	Weight each	Order Code YMT-582	Price/1 TB
165mm	185g	-4920K	429.00

Universal Joint

3/8 High polished chrome finish. Hinged through 180° in both directions.



Drive Male x Female	Overall Length	Weight each	Order Code YMT-582	Price/1 TB
3/8" x 3/8"	50mm	60g	-5040K	158.00

Spinner Handle Fixed Type

3/8 Chrome vanadium steel blade, polypropylene handle and spring loaded bearing socket retainer.



Overall Length	Weight each	Order Code KEN-582	Price/1 TB
210mm	240g	-5100K	316.00

Sliding 'T' Handle

3/8 Made from high quality chrome vanadium with a fully polished finish. The sliding bar gives many options for leverage within any space.



Overall Length	Weight each	Order Code KEN-582	Price/1 TB
165mm	185g	-4920K	258.00

Speed Braces

3/8 Manufactured from high quality chrome vanadium, fully polished finish. Ideal for nut spinning.

Rubber Grip
KEN -582-5080K



Grip	Overall Length	Weight each	Order Code KEN-582	Price/1 TB
American	425mm	500g	-5090K	731.00
Pattern	470mm	410g	-5030K	514.00
Rubber Grip	400mm	470g	-5080K	470.00

KENNEDY PROFESSIONAL Universal Joint

3/8 Hinged through 180° in both directions. Knurled for extra grip.



Drive Male x Female	Overall Length	Weight each	Order Code KEN-582	Price/1 TB
3/8" x 3/8"	50mm	60g	-5040K	252.00

HAND TOOLS

Socket Styles

Used in automotive and aerospace. The weight to strength ratio ensures the reliability and accessibility that is so important in this type of production environment.



Bi-Hexagon Sockets

12 point – side drive design gives a higher torque than normal sockets, grip worn nuts and will not round off existing nuts. All have a ball-retaining groove on each face of the square drive, which ensures a positive fit with accessories. Require only a one-twelfth turn to engage the next point of the socket.



Single-Hexagon Sockets

6 point - Offer a more positive location, particularly on worn or rounded nuts, but require a one-sixth turn to engage the next point of the socket.



TX Sockets

Chrome vanadium. For use with male headed TX fasteners commonly found in the automotive industry. 29mm overall length and each weighing 45g.



Size	Order Code KEN-582	Price/1 TB
E6	-5960K	132.00
E8	-5962K	163.00
E10	-5964K	163.00
E12	-5966K	163.00
E14	-5968K	163.00
E16	-5970K	163.00

Bi-Hexagon Standard Length Sockets



Type	Size	Overall Length	Weight each
Metric	6mm	26	30g
	7mm	26	30g
	8mm	26	30g
	9mm	26	30g
	10mm	26	30g
	11mm	26	30g
	12mm	26	30g
	13mm	26	30g
	14mm	30	40g
	15mm	30	40g
	16mm	30	50g
AF	17mm	30	60g
	18mm	30	70g
	19mm	30	70g
	20mm	30	80g
	21mm	30	80g
	22mm	27	100g
	1/4"	27	30g
	5/16"	27	30g
	11/32"	27	30g
	3/8"	27	30g
	7/16"	27	30g
1/2"	27	30g	
Whit	9/16"	27	40g
	5/8"	27	50g
	11/16"	30	60g
	3/4"	25	70g
	13/16"	27	80g
	7/8"	27	10g
	1/8"	27	35g
	3/16"	27	45g
	1/4"	30	45g
	5/16"	30	45g
	3/8"	30	45g
7/16"	30	85g	
1/2"	30	120g	

Order Code KEN-582	Price/1 TB
-5240K	70.00
-5250K	70.00
-5260K	70.00
-5270K	70.00
-5280K	70.00
-5290K	88.00
-5300K	88.00
-5310K	88.00
-5320K	88.00
-5330K	91.00
-5340K	91.00
-5350K	100.00
-5360K	100.00
-5370K	100.00
-5380K	121.00
-5390K	125.00
-5400K	129.00
-5430K	88.00
-5440K	88.00
-5450K	88.00
-5460K	88.00
-5470K	88.00
-5480K	88.00
-5490K	95.00
-5500K	100.00
-5510K	100.00
-5520K	100.00
-5530K	163.00
-5540K	195.00
-5580K	63.00
-5590K	63.00
-5600K	88.00
-5610K	88.00
-5620K	114.00
-5630K	125.00
-5640K	163.00

Order Code YMT-582	Price/1 TB
-5240K	51.00
-5250K	51.00
-5260K	51.00
-5270K	51.00
-5280K	51.00
-5290K	51.00
-5300K	51.00
-5310K	51.00
-5320K	51.00
-5330K	51.00
-5340K	51.00
-5350K	51.00
-5360K	51.00
-5370K	70.00
-5380K	70.00
-5390K	70.00
-5400K	70.00
-5430K	70.00
-5440K	70.00
-5450K	70.00
-5460K	70.00
-5470K	70.00
-5480K	70.00
-5490K	70.00
-5500K	70.00
-5510K	70.00
-5520K	70.00
-5530K	70.00
-5540K	70.00
-	-
-	-
-	-
-	-
-	-

Deep Sockets



Type	Size	Overall Length	Weight each
Metric	8mm	62	40g
	9mm	62	40g
	10mm	62	50g
	11mm	62	50g
	12mm	62	60g
	13mm	62	60g
	14mm	62	70g
	15mm	62	100g
	16mm	62	115g
	17mm	62	130g
	18mm	64	120g
AF	19mm	64	140g
	21mm	64	155g
	22mm	64	200g
	3/8"	63	45g
	7/16"	63	50g
	1/2"	63	60g
	9/16"	63	60g
	5/8"	65	110g
	11/16"	65	120g
	3/4"	65	135g
	13/16"	65	160g

Order Code KEN-582	Price/1 TB
-5700K	125.00
-5710K	125.00
-5720K	125.00
-5730K	125.00
-5740K	139.00
-5750K	139.00
-5760K	139.00
-5770K	139.00
-5780K	139.00
-5790K	146.00
-5800K	163.00
-5810K	195.00
-5820K	195.00
-5830K	200.00
-5870K	144.00
-5880K	144.00
-5890K	144.00
-5900K	154.00
-5910K	159.00
-5920K	170.00
-5930K	182.00
-5940K	189.00

Order Code YMT-582	Price/1 TB
-	-
-	-
-5720K	83.00
-5730K	83.00
-5740K	83.00
-5750K	83.00
-5760K	83.00
-5770K	83.00
-	-
-5790K	83.00
-	-
-5810K	158.00
-	-
-5830K	153.00
-5870K	116.00
-5880K	116.00
-5890K	116.00
-5900K	116.00
-5910K	116.00
-5920K	116.00
-5930K	116.00
-5940K	140.00

Single-Hexagon Standard Length



Type	Size	Overall Length	Weight each	Order Code KEN-582	Price/1 TB
Metric Single Hex	6mm	26	30g	-5554K	195.00
	7mm	26	30g	-5555K	195.00
	8mm	26	30g	-5556K	195.00
	9mm	26	30g	-5557K	195.00
	10mm	26	30g	-5558K	195.00
	11mm	26	30g	-5559K	195.00
	12mm	26	30g	-5560K	195.00
	13mm	26	30g	-5561K	195.00
	14mm	30	40g	-5562K	195.00
	15mm	30	40g	-5563K	195.00
	16mm	30	50g	-5564K	307.00
AF	17mm	30	60g	-5565K	307.00
	18mm	30	70g	-5566K	307.00
	19mm	30	70g	-5567K	307.00

HAND TOOLS

SOCKETS & ACCESSORIES - 3/8" SQUARE DRIVE

KENNEDY PROFESSIONAL Double Lug

3/8" Chrome vanadium.
For connecting two female square drives. 25mm long.



Drive Male x Male	Weight each	Order Code KEN-582	Price/1 TB
3/8" x 3/8"	10g	-5170K	307.00

Female/Male Converters

3/8" Chrome vanadium.
For using a combination of square drive socketry in the same application.



Drive Female x Male	Weight each	Order Code KEN-582	Price/1 TB
3/8" x 1/4"	20g	-5180K	97.00
3/8" x 1/2"	40g	-5190K	185.00
1/2" x 3/8"	50g	-6700K	170.00

Hex Bit Adaptor

3/8" Chrome vanadium.
For converting square drive tooling to use hexagon bits.



Drive x Hex	Overall Length	Weight each	Order Code KEN-582	Price/1 TB
3/8" x 1/4"	30mm	30g	-5200K	125.00

Spark Plug Sockets

3/8" Designed for insertion and removal of the spark plug. The neoprene insert helps retain and protect the insulation from accidental damage.



Size (Plug)	Overall Length	Weight each	Order Code KEN-582	Price/1 TB
M10	65mm	110g	-5670K	166.00
M12	65mm	110g	-5680K	170.00
M14	68mm	140g	-5660K	197.00

YAMOTO INDUSTRIAL SOCKET SETS Spark Plug Sockets

3/8" For insertion and removal of spark plugs. Neoprene insert helps retain the spark plug and protect the insulation material from damage.



Size (Plug)	Overall Length	Weight each	Order Code YMT-582	Price/1 TB
M10	65mm	110g	-5670K	158.00
M14	68mm	140g	-5660K	158.00

Hex Bit Adaptor

3/8" Chrome vanadium.
For converting square drive tooling to use hexagon bits.



Drive x Hex	Overall Length	Weight each	Order Code YMT-582	Price/1 TB
3/8" x 1/4"	30mm	15g	-5200K	129.00

Screwdriver Bit Sockets

Often used in the automotive and aerospace industries. The weight to strength ratio ensures the reliability and accessibility that is important in this type of environment. Made from chrome vanadium steel, fully chrome plated with an aluminium free mirror finish. All have ball retaining grooves. Conform to **DIN standards**.



Size	Bit Lgth (mm)	Overall Lgth (mm)	Weight each	KEN-582		YAMOTO INDUSTRIAL SOCKET SETS	
				Order Code	Price/1 TB	Order Code	Price/1 TB
Hexagon							
3mm	20	50	25g	-6000K	215.00	-6000K	135.00
4mm	20	50	30g	-6010K	215.00	-6010K	153.00
5mm	20	50	30g	-6020K	215.00	-6020K	176.00
6mm	20	50	35g	-6030K	215.00	-6030K	181.00
8mm	20	50	45g	-6040K	215.00	-6040K	191.00
10mm	20	50	55g	-6050K	215.00	-6050K	196.00
1/8"	20	50	25g	-6080K	215.00	-	-
5/32"	20	50	30g	-6090K	215.00	-	-
3/16"	20	50	30g	-6100K	215.00	-	-
7/32"	20	50	35g	-6110K	215.00	-	-
1/4"	20	50	40g	-6120K	215.00	-	-
5/16"	20	50	45g	-6130K	215.00	-	-
3/8"	20	50	55g	-6140K	226.00	-	-
Crosspoint							
No 1	20	50	50g	-6201K	170.00	-6201K	135.00
No 2	20	50	50g	-6202K	170.00	-6202K	135.00
No 3	20	50	55g	-6203K	170.00	-6203K	135.00
No 4	20	50	55g	-6204K	170.00	-	-
PZ							
No 1	20	50	50g	-6211K	170.00	-	-
No 2	20	50	50g	-6212K	170.00	-	-
No 3	20	50	55g	-6213K	170.00	-	-
Slotted							
3/16"	20	50	50g	-6222K	170.00	-6222K	135.00
7/32"	20	50	50g	-6223K	170.00	-	-
1/4"	20	50	55g	-6224K	170.00	-6224K	135.00
TX							
T6	20	50	50g	-6231K	160.00	-	-
T7	20	50	50g	-6232K	170.00	-	-
T8	20	50	50g	-6233K	170.00	-	-
T9	20	50	50g	-6234K	208.00	-	-
T10	20	50	50g	-6235K	208.00	-6235K	135.00
T15	20	50	50g	-6236K	208.00	-6236K	135.00
T20	20	50	55g	-6237K	208.00	-6237K	153.00
T25	20	50	50g	-6238K	208.00	-6238K	153.00
T27	20	50	55g	-6239K	208.00	-	-
T30	20	50	55g	-6241K	215.00	-6241K	153.00
T40	20	50	55g	-6242K	215.00	-6242K	153.00
T45	20	50	55g	-6243K	215.00	-	-
T50	20	50	55g	-6244K	215.00	-6244K	153.00

HAND TOOLS

KENNEDY PROFESSIONAL Long Screwdriver Bit Sockets & Socket Bit Sets

Ideal for accessing deep seated bolts that have been fitted knurled bodies for extra grip. Made from S2 chrome vanadium. Supplied on storage rail.

Hexagon



6 Piece Set Contents:
4, 5, 6, 7, 8, 10mm.

6 PIECES

TX



6 Piece Set Contents:
T20, T25, T30, T40 T45 and T50

Bit Sets

Description	Weight each	Order Code KEN-582	Price/1 TB
Hexagon 6 Piece Set	310g	-6324K	1591.00
TX 6 Piece Set	410g	-6340K	1645.00

Individual Bits - Hexagon

Size	Overall Length	Weight each	Order Code KEN-582	Price/1 TB
4mm	100mm	40g	-6314K	322.00
5mm	100mm	40g	-6315K	322.00
6mm	100mm	45g	-6316K	322.00
7mm	100mm	45g	-6317K	322.00
8mm	100mm	55g	-6318K	322.00
10mm	100mm	65g	-6320K	322.00

Individual Bits - TX

Size	Overall Length	Weight each	Order Code KEN-582	Price/1 TB
T20	95mm	65g	-6330K	327.00
T25	95mm	65g	-6331K	327.00
T30	95mm	65g	-6332K	327.00
T40	95mm	65g	-6334K	327.00
T45	95mm	65g	-6335K	327.00
T50	95mm	65g	-6336K	327.00

PRODUCTS ARE ONLY AVAILABLE VIA YOUR DISTRIBUTOR

GROUP 582

SOCKETS & ACCESSORIES - 1/2" SQUARE DRIVE

1/2" DRIVE: The most popular drive size used in the service and maintenance industries. This popularity is due to its strength and robust nature.

KENNEDY PROFESSIONAL Lever Reversible Rubber Handle



1/2" Chrome vanadium. Rubber grip, 72 tooth ratchet. With thumb lever for reversing without having to remove the socket or accessory. With quick release. A high quality wrench for the professional user.



Overall Length	Number of Teeth	Weight each	Order Code KEN-582	Price/1 TB
240mm	72	430	-6422K	3216.00

Push Through Rubber Handle

1/2" A very economic wrench with a one way ratchet. Push through square drive allows left and right hand operation.



Overall Length	Number of Teeth	Weight each	Order Code KEN-582	Price/1 TB
270mm	30	500g	-6430K	2997.00

Lever Reversible Steel Handle

1/2" Fully chromed all steel handle with thumb lever for reversing without having to remove the socket or accessory.



Overall Length	Number of Teeth	Weight each	Order Code KEN-582	Price/1 TB
250mm	72	510g	-6412K	3147.00

Lever Reversible Steel Handle Flexi-Joint

1/2" Fully chromed lever type. All steel handle. The hinged joint gives additional capability in areas of restricted access.



Type	Overall Length	Weight each	Order Code KEN-582	Price/1 TB
Standard	420	860g	-6370K	1482.00
Stubby	198	110g	-6375K	1327.00

YAMOTO INDUSTRIAL SOCKET SETS Universal Joint

1/2" Hinged through 180° in both directions. Knurled for extra grip.



Drive M x F	Overall Length	Weight each	Order Code YMT-582	Price/1 TB
1/2" x 1/2"	75mm	155g	-6580K	266.00

KENNEDY QUALITY INDUSTRIAL TOOLING Ratchet Repair Kits



To suit Ratchet Number	Order Code KEN-582	Price/1 TB
KEN-582-6400K	-6740K	927.00
KEN-582-6412K/-6422K	-6725K	876.00
KEN-582-6380K/-6390K	-6745K	1133.00

Universal Joint

1/2" Hinged through 180° in both directions. Knurled for extra grip.



Drive M x F	Overall Length	Weight each	Order Code KEN-582	Price/1 TB
1/2" x 1/2"	75mm	155g	-6580K	339.00

Push Through Steel Handle - Gearless

1/2" Chrome - molybdenum with mirror polished finish. Push through square drive, needs only 3% movement to operate gearless ratchet.



Overall Length	Weight each	Order Code KEN-582	Price/1 TB
250mm	470g	-6435K	1969.00

Disc Type Steel Handle

1/2" Basic wrench with high polished finish. Fitted with spring loaded ball bearing socket retainer.



Product Number	Number of Teeth	Weight each	Order Code KEN-582	Price/1 TB
245mm	44	655g	-6400K	1640.00

YAMOTO INDUSTRIAL SOCKET SETS Quick Release Ratchet Handle



1/2" With thumb lever for reversing without having to remove the socket or accessory. Highly polished chrome vanadium with rubber grip.



Overall Length	Number of Teeth	Weight each	Order Code YMT-582	Price/1 TB
250mm	72	510g	-6412K	2382.00

Composite Ratchet Handle

1/2" Quality composite reversible ratchet handle with reverse lever, push button quick release and an offset handle to help eliminate knuckle scrapes. Manufactured from composite material making it very light yet still very hard wearing. 72-tooth gear drive for maximum power and chrome vanadium core for strength.



Overall Length	Number of Teeth	Weight each	Order Code YMT-582	Price/1 TB
250mm	72	435g	-7512K	1859.00

SENATOR QUALITY TOOLING Lever Reversible Rubber Handle



1/2" With thumb lever for reversing without having to remove the socket or accessory. Highly polished chrome vanadium with rubber grip.



Overall Length	Number of Teeth	Weight each	Order Code SEN-582	Price/1 TB
245mm	44	640g	-6400K	737.00

HAND TOOLS

SOCKETS & ACCESSORIES - 1/2" SQUARE DRIVE

KENNEDY PROFESSIONAL Speed Braces

1/2 Rubber grip, for fast nut spinning. Manufactured from high quality chrome vanadium, fully polished finish. Ideal for nut spinning.



Handle Type	Overall Length	Weight each	Order Code KEN-582	Price/1 TB
Rubber Grip	400mm	470g	-6560K	698.00
Steel Grip	425mm	510g	-6600K	1045.00

Extension Bars

1/2 Manufactured from high quality chrome vanadium with a fully polished finish. All with knurled 'finger grip'.

Standard



Overall Length	Weight each	Order Code KEN-582	Price/1 TB
75mm	140g	-6460K	215.00
125mm	225g	-6480K	246.00
250mm	440g	-6500K	371.00
375mm	630g	-6520K	839.00
450mm	735g	-6530K	842.00

Wobble

In areas where clearance may be a problem the 'wobble' square drive can be used at an angle of up to 15°.



Overall Length	Weight each	Order Code KEN-582	Price/1 TB
75mm	65g	-6630K	270.00
125mm	120g	-6640K	290.00
250mm	260g	-6660K	415.00

Locking

A lever at the ratchet end of the extension pushes down a rod inside the bar which locks out the socket retaining ball, securing the socket to the bar. Ideal for use where there is a risk of leaving a socket in a recess.



Overall Length	Weight each	Order Code KEN-582	Price/1 TB
375mm	65g	-6670K	1577.00

Sliding 'T' Handle

1/2 Manufactured from high quality chrome vanadium with a fully polished finish. The sliding bar will give many options for leverage within a given space.



Overall Length	Weight each	Order Code KEN-582	Price/1 TB
250mm	360g	-6440K	476.00

YAMOTO INDUSTRIAL SOCKET SETS Sliding 'T' Handle

1/2 Manufactured from high quality chrome vanadium with a fully polished finish. The sliding bar will give many options for leverage within a given space.



Overall Length	Order Code YMT-582	Price/1 TB
250mm	-6370K	424.00

Extension Bars

1/2 Chrome finish.



Overall Length	Weight each	Order Code YMT-582	Price/1 TB
75mm	125g	-6460K	146.00
125mm	195g	-6480K	195.00
250mm	385g	-6500K	316.00

KENNEDY PROFESSIONAL Swivel Handles

1/2 The hinged link allows operation at varied angles to aid access in restricted areas.



Grip	Overall Length	Weight each	Order Code KEN-582	Price/1 TB
Rubber	300mm	645g	-6570K	876.00
American	375mm	540g	-6540K	1093.00
American	450mm	830g	-6550K	1326.00

Grip	Overall Length	Weight each	Order Code KEN-582	Price/1 TB
American	450mm	1099g	-6545K	1577.00
American	600mm	1376g	-6555K	2080.00

Service Parts	
Replacement Knuckle	-6548K 446.00

1/2 Flexi-Ring End Sockets

Made from polished chrome vanadium. These tough flexi-ring end sockets are designed to allow access over long studs and for awkwardly positioned nuts and bolts. Swivels through 220°.

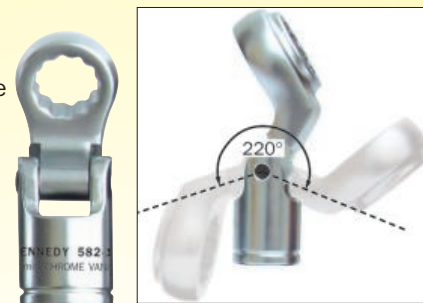

Type	Size	Overall Length	Weight each	Order Code KEN-582	Price/1 TB
Metric	13mm	70mm	124g	-1180K	274.00
	14mm	70mm	123g	-1181K	301.00
	15mm	70mm	121g	-1182K	313.00
1/2	16mm	70mm	119g	-1183K	313.00
	17mm	77mm	158g	-1184K	339.00
	19mm	77mm	152g	-1185K	339.00
	22mm	82mm	193g	-1186K	357.00
	24mm	86mm	213g	-1187K	384.00

8 Piece Metric Set Contents:

13, 14, 15, 16, 17, 19, 22, and 24mm. Supplied with a sturdy hanging rail.



Number of Pieces	Contents	Weight each	Order Code KEN-582	Price/1 TB
8	As above	1.3kg	-1190K	2733.00

Offset Fixed Handle

1/2 Knurled grip. Chrome vanadium. Fixed wrench for applications requiring rigid set up.



Overall Length	Weight each	Order Code KEN-582	Price/1 TB
200mm	255g	-6590K	499.00

YAMOTO INDUSTRIAL SOCKET SETS Swivel Handles

1/2 With hinged link and rubber grip.



Overall Length	Weight each	Order Code YMT-582	Price/1 TB
300mm	645g	-6570K	720.00
380mm	770g	-6575K	823.00

HAND TOOLS

Bi-Hexagon Standard Length Sockets



KENNEDY PROFESSIONAL

YAMOTO INDUSTRIAL SOCKET SETS

Type	Size	Overall Length	Weight each
	8mm	36	50g
	9mm	37	50g
	10mm	37	50g
	11mm	37	50g
	12mm	37	50g
	13mm	37	50g
	14mm	37	50g
	15mm	37	60g
	16mm	37	60g
	17mm	37	60g
	18mm	37	80g
	19mm	37	70g
Metric	20mm	37	80g
	21mm	37	70g
	22mm	37	90g
	23mm	37	110g
	24mm	37	110g
	25mm	40	150g
	26mm	40	140g
	27mm	40	170g
	28mm	40	170g
	29mm	40	170g
	30mm	45	210g
	32mm	45	230g
	33mm	45	230g
	36mm	45	245g
	5/16"	37	50g
	3/8"	37	50g
	7/16"	37	50g
	1/2"	37	50g
	9/16"	37	50g
	19/32"	37	60g
	5/8"	37	60g
AF	11/16"	37	60g
	3/4"	37	70g
	13/16"	37	80g
	7/8"	40	90g
	15/16"	40	110g
	1"	40	130g
	1 1/16"	40	160g
	1 1/8"	40	170g
	1 3/16"	45	200g
	1 1/4"	45	230g
	1/8"	37	50g
	3/16"	37	50g
	1/4"	37	50g
	5/16"	37	60g
Whit	3/8"	37	50g
	7/16"	37	70g
	1/2"	40	90g
	9/16"	40	140g
	5/8"	40	170g
	11/16"	45	220g
	3/4"	45	220g

Order Code	Price/1 TB
KEN-582	
-6900K	141.00
-6910K	141.00
-6920K	141.00
-6930K	141.00
-6940K	141.00
-6950K	141.00
-6960K	141.00
-6970K	148.00
-6980K	148.00
-6990K	154.00
-7000K	167.00
-7010K	167.00
-7020K	221.00
-7030K	221.00
-7040K	235.00
-7050K	246.00
-7060K	256.00
-7070K	308.00
-7080K	315.00
-7090K	317.00
-7100K	342.00
-7110K	346.00
-7120K	356.00
-7130K	397.00
-7140K	503.00
-7150K	628.00
-7160K	125.00
-7170K	146.00
-7180K	146.00
-7190K	146.00
-7200K	151.00
-7210K	151.00
-7220K	157.00
-7230K	163.00
-7240K	170.00
-7250K	221.00
-7260K	252.00
-7270K	252.00
-7280K	290.00
-7290K	296.00
-7300K	352.00
-7310K	359.00
-7320K	384.00
-7380K	199.00
-7390K	199.00
-7400K	199.00
-7410K	199.00
-7420K	199.00
-7430K	199.00
-7440K	199.00
-7450K	270.00
-7460K	270.00
-7470K	322.00
-7480K	446.00

Order Code	Price/1 TB
YMT-582	
-6900K	77.00
-6910K	77.00
-6920K	77.00
-6930K	77.00
-6940K	77.00
-6950K	77.00
-6960K	77.00
-6970K	77.00
-6980K	77.00
-6990K	77.00
-7000K	77.00
-7010K	88.00
-7020K	129.00
-7030K	133.00
-7040K	133.00
-7050K	133.00
-7060K	133.00
-7070K	140.00
-7080K	140.00
-7090K	150.00
-7100K	150.00
-7110K	160.00
-7120K	170.00
-7130K	181.00
-7140K	266.00
-7150K	361.00
-7160K	86.00
-7170K	86.00
-7180K	86.00
-7190K	86.00
-7200K	86.00
-7220K	86.00
-7230K	86.00
-7240K	86.00
-7250K	153.00
-7260K	153.00
-7270K	153.00
-7280K	153.00
-7290K	153.00
-7300K	184.00
-7320K	214.00
-7390K	153.00
-7400K	153.00
-7410K	153.00
-7420K	153.00
-7430K	153.00
-7440K	153.00
-7450K	153.00
-7460K	153.00

Socket Styles

Used in automotive and aerospace. The weight to strength ratio ensures the reliability and accessibility that is so important in this type of production environment.

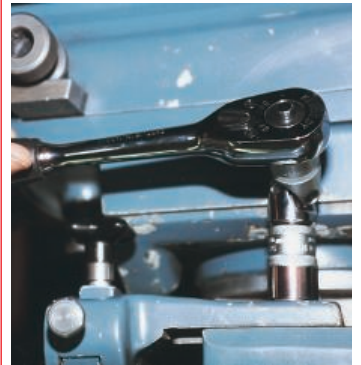

Bi-Hexagon Sockets

12 point - side drive design gives a higher torque than normal sockets, grip worn nuts and will not round off existing nuts. All have a ball-retaining groove on each face of the square drive, which ensures a positive fit with accessories. Require only a one-twelfth turn to engage the next point of the socket.

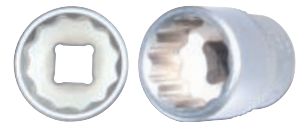

Single Hexagon Sockets

Six point - offer a more positive location, particularly on worn or rounded nuts, but require a one-sixth turn to engage the next point of the socket.



HAND TOOLS

KENNEDY QUALITY INDUSTRIAL TOOLING **Single Hexagon Standard Length Sockets**

Six point - offer a more positive location, particularly on worn or rounded nuts, but require a one-sixth turn to engage the next point of the socket.



Type	Size	Overall Length	Weight each	Order Code	Price/1 TB
	8mm	36	50g	-7346K	359.00
	9mm	37	50g	-7347K	359.00
	10mm	37	50g	-7348K	359.00
	11mm	37	50g	-7349K	359.00
	12mm	37	50g	-7350K	359.00
	13mm	37	50g	-7351K	359.00
	14mm	37	50g	-7352K	389.00
	15mm	37	60g	-7353K	389.00
	16mm	37	60g	-7354K	389.00
	17mm	37	60g	-7355K	408.00
	18mm	37	80g	-7356K	408.00
	19mm	37	70g	-7357K	408.00
	20mm	37	80g	-7358K	408.00
	21mm	37	70g	-7359K	408.00
	22mm	37	90g	-7360K	408.00
	23mm	37	110g	-7361K	416.00
	24mm	37	110g	-7362K	416.00
	26mm	40	140g	-7364K	416.00
	27mm	40	170g	-7365K	504.00
	28mm	40	170g	-7366K	504.00
	30mm	45	210g	-7368K	504.00
	32mm	45	230g	-7370K	581.00
	36mm	45	245g	-7374K	811.00

Bi-Hexagon Deep Sockets



Type	Size	Overall Length	Weight each	Order Code	Price/1 TB
	10mm	77	100g	-7530K	225.00
	11mm	77	110g	-7540K	225.00
	12mm	77	110g	-7550K	225.00
	13mm	77	110g	-7560K	225.00
	14mm	77	110g	-7570K	225.00
	15mm	77	130g	-7580K	225.00
Metric	16mm	77	120g	-7590K	225.00
	17mm	77	120g	-7600K	231.00
	18mm	77	150g	-7610K	233.00
	19mm	77	150g	-7620K	244.00
	21mm	77	160g	-7630K	322.00
	22mm	77	200g	-7640K	324.00
	24mm	77	220g	-7650K	312.00
	26mm	77	210g	-7660K	414.00
	27mm	77	250g	-7670K	435.00
	30mm	77	320g	-7680K	499.00
	32mm	77	340g	-7690K	569.00
	1/2"	77	110g	-7700K	408.00
	9/16"	77	100g	-7710K	408.00
	5/8"	77	120g	-7720K	408.00
	11/16"	77	110g	-7730K	408.00
	3/4"	77	140g	-7740K	408.00
	13/16"	77	160g	-7750K	408.00
	7/8"	77	190g	-7760K	408.00
	15/16"	77	220g	-7770K	408.00
	1"	77	200g	-7780K	408.00
	1 1/8"	77	270g	-7790K	573.00
	1 1/4"	77	390g	-7800K	698.00

SOCKETS & ACCESSORIES - 1/2" SQUARE DRIVE

KENNEDY PROFESSIONAL E-TX S Sockets

1/2 Chrome vanadium. For use with male headed TX fasteners commonly found in the automotive industry.



Size (Plug)	Overall Length	Weight each	Order Code KEN-582	Price/1 TB
E10	37mm	50g	-7485K	199.00
E12	37mm	55g	-7487K	199.00
E14	37mm	55g	-7489K	199.00
E16	37mm	55g	-7491K	199.00
E18	37mm	70g	-7493K	199.00
E20	37mm	90g	-7495K	199.00

Double Ended Lug

1/2 Chrome vanadium. For connecting two female square drives.



Drive Male x Male	Weight each	Order Code KEN-582	Price/1 TB
1/2" x 1/2"	35g	-6750K	405.00

Hex Bit Adaptors

1/2 Chrome vanadium. For converting square drive tooling to use hexagon bits.



Drive x Hex	Overall Length	Weight each	Order Code KEN-582	Price/1 TB
1/2" x 3/4"	35mm	40g	-6710K	200.00
1/2" x 5/16"	75mm	45g	-6720K	209.00

Female/Male Converters

1/2 Chrome vanadium. For using a combination of square drive socketry in the same application.

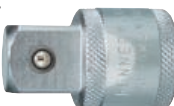

Drive Female x Male	Weight each	Order Code KEN-582	Price/1 TB
3/8" x 1/2"	40g	-5190K	185.00
1/2" x 3/4"	40g	-6680K	476.00
1/2" x 3/8"	50g	-6700K	170.00
3/4" x 1/2"	55g	-8120K	535.00

Spark Plug Sockets

1/2 Designed for insertion/ removal of spark plugs. The neoprene insert helps retain the spark plug and protect the insulation material from accidental damage. A unique double knurl gives a high grip essential for a quick tool change when hands are greasy.



Size (Plug)	Overall Length	Weight each	Order Code KEN-582	Price/1 TB
M10	65mm	85g	-7520K	233.00
M14	67mm	150g	-7500K	280.00

YAMOTO INDUSTRIAL SOCKET SETS Spark Plug Sockets

1/2 A neoprene insert helps retain the spark plug and protect the insulation material from accidental damage. A ball-retaining groove on each face ensures a positive fit with all accessories. Chamfered leading edge gives easy location.



Size (Plug)	Overall Length	Weight each	Order Code YMT-582	Price/1 TB
M10	65mm	85g	-7520K	176.00
M14	67mm	150g	-7500K	197.00

Screwdriver Bits

For insertion and removal of fasteners and fixings using 1/2" square drive tooling. Made from chrome vanadium steel, fully chrome plated with a mirror finish and aluminium-free to ensure non-sparking. All have ball retaining groove on each face of the square drive.



Conform to **DIN standards.**

Size	Bit Lgth (mm)	Overall Lgth (mm)	Weight each
⊖ Slotted			
8mm	20	55	80g
9mm	20	55	80g
10mm	20	55	90g
12mm	20	55	100g
14mm	20	55	130g
16mm	20	55	140g

Size	Bit Lgth (mm)	Overall Lgth (mm)	Weight each
⊙ Hexagon			
4mm	20	55	80g
5mm	20	55	70g
6mm	20	55	70g
7mm	20	55	70g
7mm	20	100	110g
8mm	20	55	70g
10mm	20	55	80g
12mm	20	55	100g
14mm	20	65	160g
17mm	20	70	205g
19mm	20	70	245g
3/16"	20	55	58g
1/4"	20	55	59g
5/16"	20	55	65g
3/8"	20	55	76g
1/2"	20	55	107g
9/16"	20	55	144g
3/4"	20	70	144g

Size	Bit Lgth (mm)	Overall Lgth (mm)	Weight each
⊕ Crosspoint			
No.2	20	55	55g
No.3	20	55	65g
No.4	20	55	70g

Size	Bit Lgth (mm)	Overall Lgth (mm)	Weight each
⊗ PZ			
No.2	17	55	70g
No.3	17	55	75g
No.4	17	55	80g

Size	Bit Lgth (mm)	Overall Lgth (mm)	Weight each
⊙ TX			
T20	20	58	60
T25	17	55	70
T27	17	55	70
T30	17	55	70
T40	17	55	70
T45	17	55	70
T50	17	55	70
T55	17	55	80
T60	17	55	105
T70	17	55	115

KENNEDY PROFESSIONAL

Order Code KEN-582	Price/1 TB
-7832K	408.00
-7834K	408.00
-7836K	408.00
-7838K	408.00
-7839K	408.00

YAMOTO INDUSTRIAL SOCKET SETS

Order Code YMT-582	Price/1 TB
-7809K	232.00
-7810K	232.00

Order Code KEN-582	Price/1 TB
-7840K	324.00
-7841K	324.00
-7842K	324.00
-7843K	324.00
-7807K	408.00
-7844K	324.00
-7845K	324.00
-7846K	324.00
-7847K	377.00
-7848K	437.00
-7849K	556.00
-7851K	324.00
-7853K	324.00
-7854K	324.00
-7855K	324.00
-7856K	324.00
-7857K	387.00
-7859K	509.00

Order Code YMT-582	Price/1 TB
-7840K	246.00
-7841K	246.00
-7842K	285.00
-7844K	285.00
-7845K	285.00
-7846K	285.00
-7847K	316.00
-7848K	346.00
-7849K	411.00

Order Code KEN-582	Price/1 TB
-7861K	509.00
-7862K	509.00
-7863K	509.00

Order Code YMT-582	Price/1 TB
-7861K	182.00
-7862K	222.00
-7863K	232.00

Order Code KEN-582	Price/1 TB
-7865K	324.00
-7866K	324.00
-7867K	324.00

Order Code YMT-582	Price/1 TB
-7865K	324.00
-7866K	324.00
-7867K	324.00

Order Code KEN-582	Price/1 TB
-7870K	324.00
-7871K	324.00
-7872K	324.00
-7873K	324.00
-7874K	324.00
-7875K	324.00
-7876K	324.00
-7877K	377.00
-7878K	377.00
-7879K	400.00

Order Code YMT-582	Price/1 TB
-7870K	324.00
-7871K	324.00
-7872K	324.00
-7873K	324.00
-7874K	324.00
-7875K	324.00
-7876K	324.00
-7877K	377.00
-7878K	377.00
-7879K	400.00

KENNEDY PROFESSIONAL Spline Screwdriver Bit Set

6 Piece set containing short bits for bolts in tight areas and long bits for accessing deep seated, tight fitted spline bolts. Handy storage rail supplied.



6 PIECES

Description	Weight each	Order Code KEN-582	Price/1 TB
6 Piece Set (M6-M14)	665g	-7340K	2457.00

Individual Bits

Size	Overall Length	Weight each	Order Code KEN-582	Price/1 TB
M6	55mm	58g	-7322K	535.00
M8	55mm	65g	-7324K	535.00
M8	100mm	84g	-7326K	535.00
M10	100mm	103g	-7328K	535.00
M12	100mm	136g	-7330K	535.00
M14	100mm	181g	-7332K	535.00

GROUP 582 SOCKETS & ACCESSORIES - 1/2" SQUARE DRIVE

KENNEDY PROFESSIONAL Screwdriver Bit Socket Sets



1/2 Used most often in the automotive and aerospace industries. The weight to strength ratio ensures the reliability and accessibility that is so important in this type of production environment. For insertion and removal of fasteners and fixings using 1/2" square drive tooling. Unique knurled body gives extra grip which is essential for a quick tool change when your hands are greasy/oily. **Registered Design No. 2053516UK.** Manufactured from chrome vanadium steel and are fully chrome plated with an aluminium free mirror finish. All have ball retaining groove on each face of the square drive. Conform to **DIN standards.**

Overall length: 55mm. **Bit length:** 20mm.

Engineers' 20 Piece Set Contents:

- Crosspoint**
No.2, 3 and 4.
- Hexagon**
4, 5, 6, 7, 8, 10, 12, 14, 17 and 19mm,
3/16", 1/4", 5/16", 3/8", 1/2", 9/16" and 3/4".

**20
PIECES**

Mechanic's 20 Piece Set Contents:

- Slotted:**
8, 9, 12, 14, and 16mm.
- TX:**
T20, T25, T27, T30, T40, T45, T50, T55 and T60.
- Crosspoint:**
No.2, 3 and 4.
- PZ**
No.2, 3 and 4.

**20
PIECES**



Number of Pieces	Contents	Weight each	Order Code KEN-582	Price/1 TB
20	As above	1.90kg	-7880K	5915.00



Number of Pieces	Contents	Weight each	Order Code KEN-582	Price/1 TB
20	As above	2.50kg	-7890K	5915.00

HAND TOOLS

Hexagon Bit and Adaptor Set

1/2 1/2" square drive bit adaptor set contains a 10mm hex, 1/2" drive hand socket. Supplied in robust storage case.

Set Contents:

- Hexagon**
4, 5, 6, 8, 10 and 12mm.

**7
PIECES**



Number of Pieces	Contents	Weight each	Order Code KEN-582	Price/1 TB
7	As above	2.55kg	-7900K	598.00

Stud Puller Set

1/2 Chrome vanadium clamping rollers grip worn or rounded fixings by compressing onto the fixing as the socket is turned, applying pressure to grip, turn and remove. Unscrews left and right hand threads.

Set Contents:

6mm, 8mm, 10mm, 12mm.

**4
PIECES**



Number of Pieces	Contents	Weight each	Order Code KEN-582	Price/1 TB
4	As above	835g	-9480K	2068.00

Stud Extractor

1/2 Manufactured from chrome alloy steel with a bright nickel and chrome finish. The locking wheel has a black oxidised finish. To use, place the extractor over the stud, then fit any 1/2" square drive handle and turn. The locking wheel moves into place to grip the stud and then remove it. 58mm outside diameter x 65mm high.



Range (mm)	Weight each	Order Code KEN-582	Price/1 TB
6 - 19	585g	-6760K	868.00

KENNEDY QUALITY INDUSTRIAL TOOLING Oil Filter Cap Wrench Set



Cap type filter wrenches manufactured from chrome vanadium with a satin finish. Use with 3/8" or 1/2" sq drive wrenches to remove paper cartridge style oil filters.

Contents: 24, 27, 30, 32, 36, 38mm & 1/2" - 3/8" adaptor.

**7
PIECES**



Diameter (mm)	Weight each	Order Code KEN-503	Price/1 TB
60 - 140	430g	-1790K	2653.00

SOCKETS & ACCESSORIES - 3/4" SQUARE DRIVE

3/4" 3/4" DRIVE: A heavy duty range designed to cope with the demands of industrial, agricultural machinery and heavy plant, static or mobile.

KENNEDY PROFESSIONAL Swivel Handle

3/4" The hinged link allows operation at varied angles to aid access in restricted areas.



Grip	Overall Length	Weight each	Order Code KEN-582	Price/1 TB
Knurled	475mm	1.90kg	-8100K	1999.00

Sliding 'T' Handle

3/4" Manufactured from high quality chrome vanadium with a fully polished finish. Sliding bar gives many options for leverage within a given space.



Overall Length	Weight each	Order Code KEN-582	Price/1 TB
450mm	1.35kg	-8040K	1102.00

Offset Fixed Handle

3/4" Knurled grip. Chrome vanadium. Fixed wrench for applications requiring rigid set up.



Overall Length	Weight each	Order Code KEN-582	Price/1 TB
300mm	255g	-8090K	979.00

Universal Joint

3/4" Knurled for extra grip.



Male x female: 3/4" x 3/4".

Overall Length	Order Code KEN-582	Price/1 TB
110mm	-8020K	1704.00

Drive Converters

3/4" For using a combination of square sockets in one application.

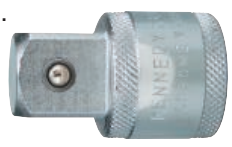

Drive F x M	Order Code KEN-582	Price/1 TB
3/4" x 1"	-8140K	721.00
1" x 3/4"	-9140K	1075.00

Bi-Hexagon Sockets

3/4" A heavy duty range designed to cope with the demands of industrial agricultural machinery and heavy plant, static or mobile. All Kennedy Professional sockets have a unique double knurl to give a high grip essential for a quick tool change when hands are greasy. Manufactured from chrome vanadium and fully chrome plated with an aluminium free mirror finish. Chamfered leading edge ensures easy fastener location. **Registered Design No. 2053516UK.**



Size	Overall Length	Weight each	Order Code KEN-582	Price/1 TB
Metric				
22	50mm	210g	-8150K	322.00
24	50mm	210g	-8170K	322.00
26	50mm	210g	-8190K	384.00
27	50mm	210g	-8200K	384.00
29	50mm	240g	-8220K	446.00
30	53mm	280g	-8230K	446.00
32	55mm	280g	-8240K	446.00
33	55mm	310g	-8250K	446.00
36	55mm	400g	-8260K	509.00
38	60mm	450g	-8280K	573.00
41	60mm	540g	-8300K	634.00
46	60mm	650g	-8320K	761.00
50	70mm	800g	-8340K	824.00
55	70mm	880g	-8360K	842.00
60	70mm	950g	-8380K	1123.00

Size	Overall Length	Weight each	Order Code KEN-582	Price/1 TB
AF				
7/8"	50mm	140g	-8400K	308.00
15/16"	50mm	160g	-8410K	308.00
1"	50mm	180g	-8420K	308.00
1 1/16"	50mm	200g	-8430K	335.00
1 1/8"	50mm	240g	-8440K	335.00
1 3/16"	54mm	250g	-8450K	361.00
1 1/4"	54mm	260g	-8460K	361.00
1 5/16"	54mm	260g	-8470K	464.00
1 3/8"	54mm	280g	-8480K	573.00
1 7/16"	57mm	280g	-8490K	634.00
1 1/2"	60mm	290g	-8500K	698.00
1 5/8"	62mm	320g	-8520K	698.00
1 11/16"	65mm	320g	-8530K	761.00
1 3/4"	65mm	330g	-8540K	793.00
1 13/16"	65mm	350g	-8550K	824.00
1 7/8"	69mm	360g	-8560K	886.00
2"	71mm	380g	-8580K	949.00

Lever Reversible Steel Handle

3/4" Spring loaded ball bearing socket retainer. A high quality wrench for the professional user.



Overall Length	Number of Teeth	Weight each	Order Code KEN-582	Price/1 TB
500mm	24	2.40kg	-8000K	5781.00

Disc Type Steel Handle

3/4" 50 tooth reversible ratchet.



Overall Length	Number of Teeth	Weight each	Order Code KEN-582	Price/1 TB
500mm	50	3.00kg	-8045K	7152.00

Non-Reversible Rubber Grip Quick Release

3/4" 36 tooth ratchet.



Overall Length	Number of Teeth	Weight each	Order Code KEN-582	Price/1 TB
480mm	36	1.50kg	-8050K	6228.00

Extension Bars

3/4" Manufactured from high quality chrome vanadium with a fully polished finish. All with knurled 'finger grip'.



Description	Overall Length	Weight each	Order Code KEN-582	Price/1 TB
Standard	100mm	432g	-8070K	634.00
	200mm	800g	-8060K	824.00
	400mm	1900g	-8080K	1515.00

Double Ended Lug

3/4" Chrome vanadium. For use in push through ratchets and similar.



Male x male: 3/4" x 3/4".

Overall Length	Order Code KEN-582	Price/1 TB
60mm	-8130K	1040.00

Ratchet Repair Kit

To suit ratchet number KEN-582- 8000K.



Weight each	Order Code KEN-582	Price/1 TB
550g	-8010K	1577.00

1" Drive The ultimate for high torque hand applications. Designed to give strength and reliability under heavy loads. Used extensively in heavy plant, rail, shipyard and oil rig industries.



Lever Type Steel Handle with Extension



Sliding 'T'-Handle with Extension

Lever Type Steel Handle

1 Basic wrench with satin finish. Fitted with spring loaded ball bearing socket retainer.



Overall Length	Number of Teeth	Weight each	Order Code KEN-582	Price/1 TB
740mm	40	5.40kg	-8980K	10446.00

Spares	Description	Order Code KEN-582	Price/1 TB
	Ratchet Repair Kit	-8990K	2936.00

Sliding 'T' Handle

1 Manufactured from high quality chrome vanadium with a fully polished finish. The sliding bar will give many options for leverage within a given space.

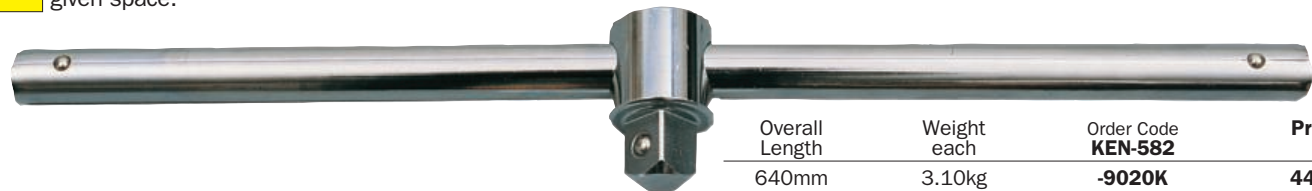

Overall Length	Weight each	Order Code KEN-582	Price/1 TB
640mm	3.10kg	-9020K	4465.00

Extensions

1 Manufactured from high quality chrome vanadium with a fully polished finish. Knurled 'finger grip'.



Description	Overall Length	Weight each	Order Code KEN-582	Price/1 TB
Standard	200mm	1.00kg	-9040K	2148.00
	400mm	1.80kg	-9060K	3501.00

Bi-Hexagon Standard Sockets

1 Bi-hexagon. (12 point). This range of 1" (25mm) series sockets is the ultimate for high torque hand applications. The Bi-hexagon design gives strength and reliability under heavy loads. Used extensively in heavy plant, rail, shipyard and oil rig industries. The 12 point bi-hexagon side drive design gives a higher torque than normal sockets. Made from chrome vanadium and fully chrome plated with an aluminium free mirror finish. Chamfered leading edge ensures easy fastener location.



Type	Size	Overall Length	Weight each	Order Code KEN-582	Price/1 TB
	36mm	65	280g	-9200K	942.00
	41mm	65	330g	-9210K	949.00
	46mm	70	360g	-9220K	1892.00
Metric	50mm	75	360g	-9230K	1898.00
	55mm	80	400g	-9240K	2019.00
1	60mm	85	420g	-9250K	2080.00
	65mm	90	450g	-9260K	2324.00
	70mm	100	480g	-9270K	2440.00
	75mm	100	520g	-9280K	3055.00
	80mm	110	550g	-9290K	3394.00
AF	1½"	70	300g	-9360K	4576.00
	2"	70	360g	-9400K	4350.00
1	2¼"	85	400g	-9420K	4703.00
	2¾"	85	400g	-9430K	5571.00



KENNEDY PROFESSIONAL **Socket Rail Trays**

Steel trays that comprise of 430mm rails with clips for retaining 1/4", 3/8" and 1/2" sq. drive sockets. Trays are fitted with carry handles and hanging holes for workshop storage.

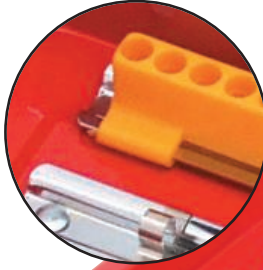

1/4" Hexagon screwdriver bit holders

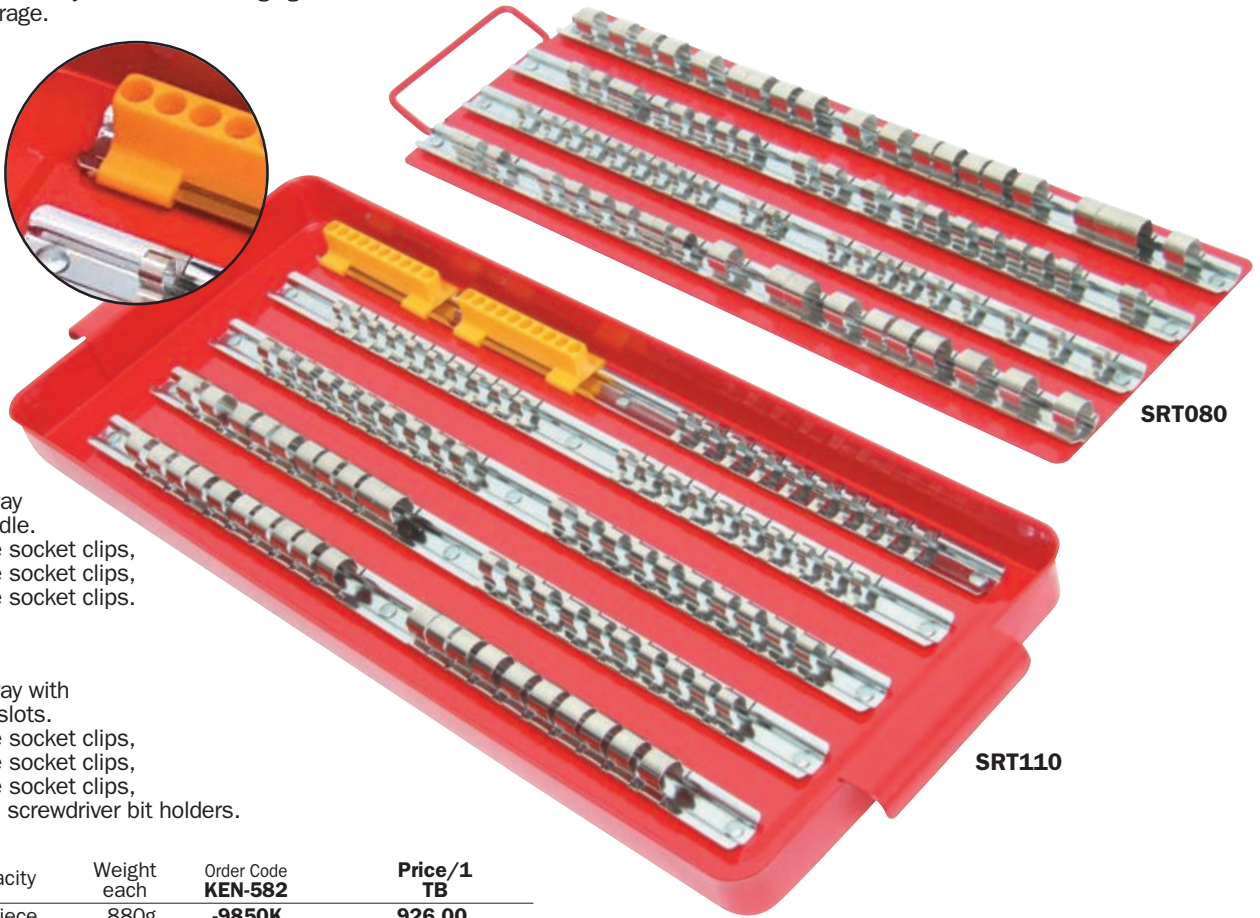

SRT080

SRT110

SRT080

Contents:

Powder coated tray with carrying handle.
30x 1/2" sq. drive socket clips,
30x 3/8" sq. drive socket clips,
20x 1/4" sq. drive socket clips.

SRT110

Contents:

Powder coated tray with integral hanging slots.
30x 1/2" sq. drive socket clips,
30x 3/8" sq. drive socket clips,
30x 1/4" sq. drive socket clips,
20x 1/4" hexagon screwdriver bit holders.

Product Number	Capacity	Weight each	Order Code KEN-582	Price/1 TB
SRT080	80 Piece	880g	-9850K	926.00
SRT110	110 Piece	1.80kg	-9860K	1597.00

KENNEDY QUALITY INDUSTRIAL TOOLING **Socket Rails & Clips**

Made from steel, bright chrome plated and can be fixed or loose in a toolbox, or fitted to a bench or wall. Can be used with any size square drive socket.



HAND TOOLS



Socket Rails

Overall Length	Weight per 10	Order Code KEN-582	Price/1 TB
220mm	290g	-9820K	65.00
420mm	430g	-9840K	100.00



Socket Clips

Sq. Drive Size	Weight per 100	Order Code KEN-582	Price/1 TB
1/4"	60g	-9880K	14.00
3/8"	90g	-9890K	15.00
1/2"	150g	-9900K	17.00

Socket Racks

Socket rails and socket clips combined together.

Sq. Drive Size	Overall Length	No of Clips	Weight each	Order Code KEN-582	Price/1 TB
1/4"	420mm	15	70g	-9920K	213.00
	220mm	8	30g	-9930K	160.00
3/8"	420mm	15	70g	-9950K	213.00
	220mm	8	30g	-9960K	160.00
1/2"	420mm	15	70g	-9980K	255.00
	220mm	8	30g	-9990K	182.00



PRODUCTS ARE ONLY AVAILABLE VIA YOUR DISTRIBUTOR

GROUP 582 SOCKET SETS - MIXED DRIVE

SENATOR QUALITY TOOLING

1/4" Drive Ideal for assembly and servicing of small precision mechanisms associated with electrical, electronic, ignition and refrigeration work.

3/8" Drive Used in the automotive and aerospace industries. The weight to strength ratio ensures the reliability and accessibility that is so important on this type of production. Sockets have a knurl feature to give a high grip which is essential for a quick tool change when your hands are greasy/oily. The 12 point bi-hexagon side drive design will give a higher torque than normal sockets, grip worn nuts and will not round off existing nuts. Manufactured from chrome vanadium and are fully chrome plated with an aluminium free mirror finish. Chamfered leading edge ensures easy fastener location. Sockets manufactured to: **ANSI B107.5M: 1987, ANSI B107.1: 1978 & BS 4006 : 1992.**

Accessories manufactured to: **ANSI B107.10M : 1982 & BS 4006 : 1992.**



SDA100MAB - 100 Piece Metric, Inch & BA

**100
PIECES**

1/4" Drive Bi-Hex Sockets:

4, 4.5, 5, 5.5, 6, 7, 8, 9, 10, 11, 12, 13mm. 3/16", 7/32", 1/4", 9/32", 5/16", 11/32", 3/8", 7/16", 1/2" AF. 0, 2, 4, 6, 8 and 10BA.

Screwdriver Bits:

Slotted 3.5, 4.5, 5.5, 6mm.
Crosspoint No.1, No.2, No.3.
PZ No.1, No.2, No.3.
TX T15, T20, T25.

Hex 3, 4, 5, 6, 8, 10mm, 1/8", 5/32", 3/16", 7/32", 1/4", 5/16", 3/8" AF.

Accessories: 50, 75 and 150mm extension bars, ratchet handle, sliding T-handle, spinner handle, universal joint.

3/8" Drive Bi-Hex Sockets:

6, 7, 8, 9, 10, 11, 12, 13, 14, 15, 16, 17, 19 and 21mm. 1/4", 5/16", 3/8", 7/16", 1/2", 9/16", 5/8", 11/16" and 3/4" AF.

Deep Sockets: 10, 11, 12, 13 and 14mm 9/16", 5/8", 11/16" and 3/4" AF.

Spark Plug Sockets: M10 (16mm) and M14 (21mm).

Accessories: 75 and 150mm extension bars, flexible handle, ratchet handle, universal joint, sliding T-handle

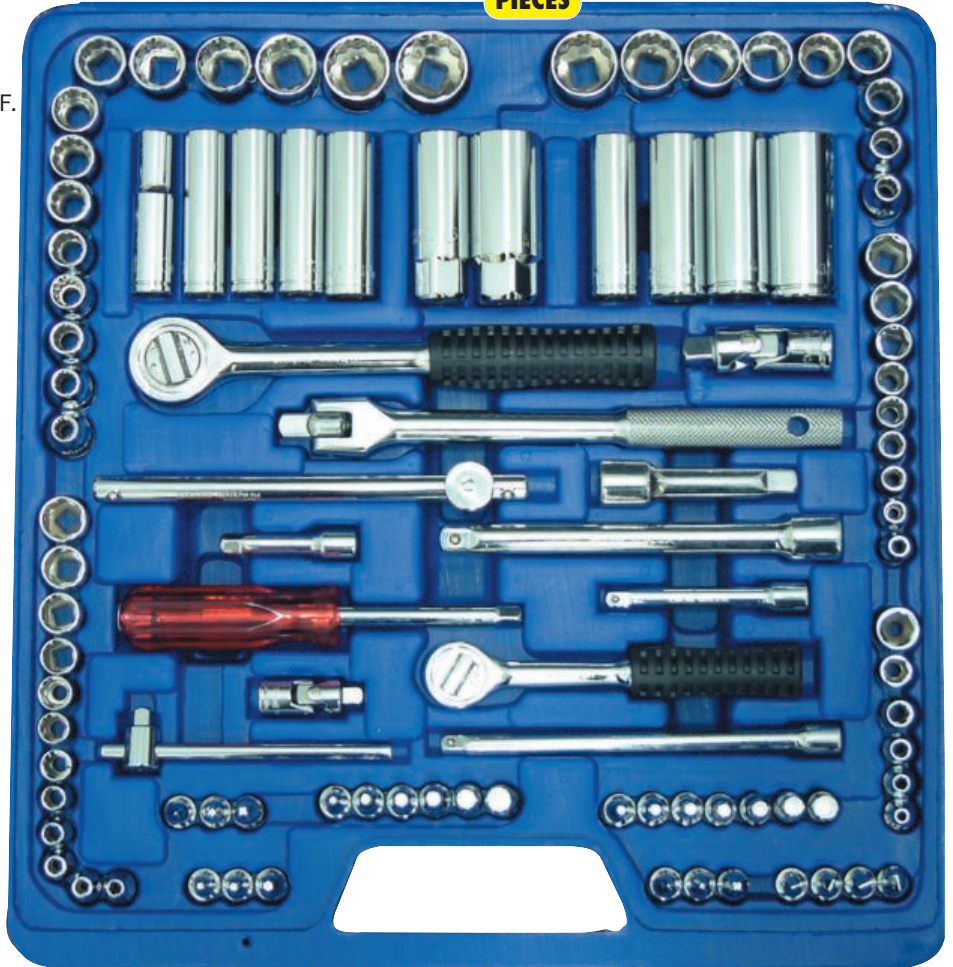

HAND TOOLS

Number of Pieces	Weight each	Order Code	Price/1 TB
100	5.00kg	-0080K	6178.00

SA40MA 40 Piece - Metric & Inch

**40
PIECES**

3/8" Drive Bi-Hex Sockets:

6, 7, 8, 9, 10, 11, 12, 13, 14, 15, 16, 17, 19 and 21mm. 1/4", 5/16", 3/8", 1/2", 9/16", 5/8", 7/16", 11/16" and 3/4" AF.

Deep Sockets: 10, 11, 12, 13 & 14mm. 9/16", 5/8", 11/16" and 3/4" AF.

Spark Plug Sockets: M10 (16mm) and M14 (21mm).

Accessories: Ratchet handle, sliding T-handle, swivel handle, universal joint. 75mm and 150mm extension bars.

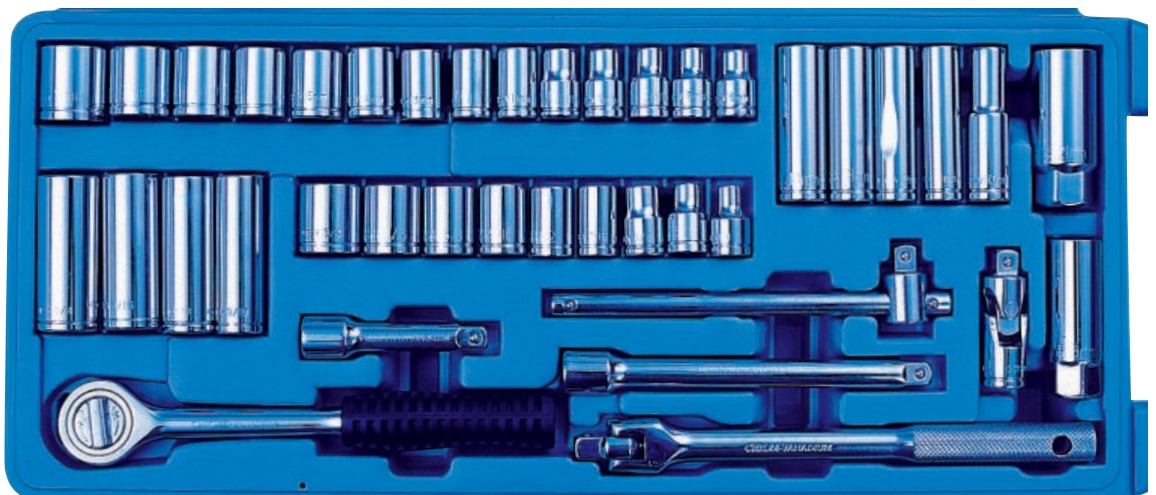

Number of Pieces	Weight each	Order Code	Price/1 TB
40	3.90kg	-0100K	4220.00

HOME IMPROVER

PRODUCTS ARE ONLY AVAILABLE VIA YOUR DISTRIBUTOR

KENNEDY PROFESSIONAL *Side Drive Socket Sets*

The Ken-Grip® socket offers a new standard of performance with the ability to grip fasteners which are up to 95% rounded off. A unique patented socket design grips new, worn and rusted fasteners without damaging them further. Double knurl feature gives a high grip which is essential for quick tool change when hands are greasy or oily. Manufactured from chrome vanadium steel, the sockets and accessories are aluminium free, fully chrome plated for a corrosion resistant, easy clean finish. The set features an extensive selection of socket sizes for use across a wide range of fasteners.

KENGRIP
Patented Design



Will grip new, worn and rusted fasteners without damaging them further



Will grip fasteners which are up to 95% rounded off

Will also fit a wide range of non-metric Hexagons, E-Torx® and Spline Drive Sizes.

1/4" Square Drive 19 Piece Metric Set

Metric Ken-Grip® Sockets: 4, 4.5, 5, 5.5, 6, 7, 8, 9, 10, 11, 12, 13, 14mm.

Accessories: ratchet handle, spinner handle, sliding T-handle, flexi-drive 145mm, universal joint, extension bar 100mm.

**19
PIECES**



Number of Pieces	Weight each	Order Code	Price/1 TB
19	880g	-8800K	6896.00

3/8" Square Drive 50 Piece Metric Set

Ken-Grip® Standard & Deep Sockets
Standard: 6, 7, 8, 9, 10, 11, 12, 13, 14, 15, 16, 17, 18, 19, 20, 21 and 22mm.
Deep: 10, 11, 12, 13, 14, 15, 17, 19 and 22mm.

Screwdriver Bits: Slotted 5, 5.5 and 6.5mm.
Crosspoint No.1, 2, 3, 4.

Sockets: 3, 4, 5, 6, 8 and 10mm.

Accessories: ratchet handle, sliding T-handle, spinner handle, swivel handle, universal joint, 125 and 250mm extensions, 250mm wobble extensions, 1/4" and 1/2" male adaptors, 1/4" socket bit coupler. Robust fitted case with security padlock hole and cushion grip handle.

**50
PIECES**



Number of Pieces	Weight each	Order Code	Price/1 TB
50	3.00kg	-8810K	11618.00

1/2" Square Drive 30 Piece Metric Set

Ken-Grip®: 8, 9, 10, 11, 12, 13, 14, 15, 16, 17, 18, 19, 20, 21, 22, 23, 24, 25, 26, 27, 30 and 32mm.

Spark Plug Sockets: M10 and M14.

Accessories: quick release ratchet handle, sliding T-handle, universal joint, 75, 125 and 250mm extension bars. Robust fitted case with security padlock hole and cushion grip handle.

**30
PIECES**



Number of Pieces	Weight each	Order Code	Price/1 TB
30	5.50kg	-8820K	10079.00

HAND TOOLS

GROUP 582 SOCKET SETS - 1/4" SQUARE DRIVE



1/4" Drive Ideal for assembly and servicing of small precision mechanisms associated with electrical, electronic, ignition and refrigeration work. Sockets have a knurl feature to give a high grip which is essential for a quick tool change when your hands are greasy/oily. The six point bi-hexagon side drive design will give a higher torque than normal sockets, grip worn nuts and will not round off existing nuts. Manufactured from chrome vanadium and are fully chrome plated with an aluminium free mirror finish. Chamfered leading edge ensures easy fastener location. Sockets made to: **ANSI B107.5M : 1987, ANSI B107.1 : 1978 & BS 4006 : 1992.** Accessories made to: **ANSI B107.10M : 1982 & BS 4006 : 1992.**



TS19M - 19 Piece Metric Socket Set

Metric Hex Sockets: 4, 4.5, 5, 5.5, 6, 7, 8, 9, 10, 11, 12, 13, 14mm.

Accessories: ratchet handle, spinner handle, sliding T-handle, flexi-drive 145mm, universal joint, extension bar 100mm.



Number of Pieces	Weight each	Order Code KEN-582	Price/1 TB
19	880g	-4893K	5713.00

TS29MA - 29 Piece Metric & Inch Socket Set

Metric Sockets: 4, 4.5, 5, 5.5, 6, 7, 8, 9, 10, 11, 12, 13, 14mm. **AF Sockets:** 3/16", 7/32", 1/4", 9/32", 5/16", 11/32", 3/8", 7/16", 1/2", 9/16".

Accessories: ratchet handle, spinner handle, sliding T-handle, flexi-drive 145mm, universal joint, extension bar 100mm.



Number of Pieces	Weight each	Order Code KEN-582	Price/1 TB
29	1.2kg	-4895K	5851.00

51 Piece Metric/AF

TSD51MA

Standard & Deep Sockets

Standard Sockets (Metric): 4, 5, 5.5, 6, 7, 8, 9, 10, 11, 12, 13, 14mm.

Deep Sockets (Metric): 6, 7, 8, 9, 10, 11, 12, 13, 14mm.

Standard Sockets (AF): 3/16", 7/32", 1/4", 9/32", 5/16", 11/32", 3/8", 7/16", 1/2", 9/16".

Deep Sockets (AF): 3/16", 7/32", 1/4", 9/32", 5/16", 11/32", 3/8", 7/16", 1/2", 9/16".

Accessories: ratchet handle (rubber grip), 100mm sliding T-handle, 100 and 250mm extension bars, 50 and 150mm wobble extensions, universal joint, spinner handle, 150mm flexible extension, swivel handle rubber grip.

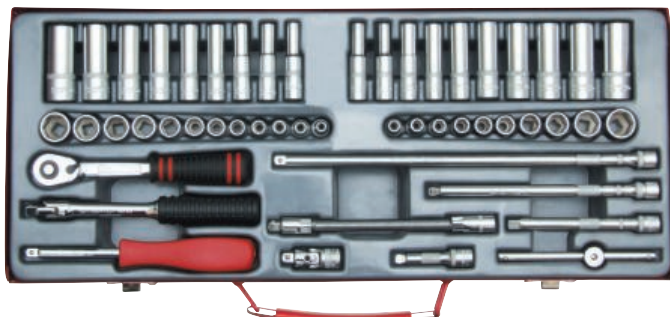

Number of Pieces	Weight each	Order Code KEN-582	Price/1 TB
51	3.2kg	-4902K	6541.00

SENATOR QUALITY TOOLING RSD43 - 43 Piece Metric & Inch

High quality chrome vanadium for garage, workshop and home maintenance.

Sockets: 6, 7, 8, 9, 10, 11, 12mm. 3/16", 1/4", 5/16", 11/32", 3/8", 7/16" and 1/2" AF.

Long Series (50mm) Bits: Slotted 4, 5, 6mm. **Crosspoint** No.1, No.2, No.3. **TX** T10, T15, T20, T25, T27, T30, T40, T45.

Short Series (25mm) Bits: **PZ** No.1, No.2. **Hex** 1.5, 2, 2.5, 3, 4, 5, 5.5 and 6mm.

Accessories: ratchet spinner handle, 150mm flexible extension bar, 100mm hex bit extension bar, 1/4" coupler, 50mm socket coupler.

HOME IMPROVER



Number of Pieces	Weight each	Order Code SEN-582	Price/1 TB
43	1.10kg	-0040K	1597.00

SD60MAB - 60 Piece Metric, Inch & BA

Sockets: 4, 4.5, 5, 5.5, 6, 7, 8, 9, 10, 11, 12 and 13mm. 3/16", 7/32", 1/4", 9/32", 5/16", 11/32", 3/8", 7/16" and 1/2" AF. 0, 2, 4, 6, 8 and 10BA.

Crossdriver Bits: Slotted 3.5, 4.5, 5.5, 6mm.

Crosspoint No.1, No.2 No.3. **PZ** No.1, No.2, No.3.

TX T15, T20 and T25. **Hex** 3, 4, 5, 6, 8 and 10mm. 1/8", 5/32", 3/16", 7/32", 1/4", 5/16", 3/8" AF.

Accessories: ratchet handle, sliding T-handle, spinner handle, universal joint. 50, 75 and 150mm extension bars,



Number of Pieces	Weight each	Order Code SEN-582	Price/1 TB
60	1.50kg	-0060K	2457.00

HAND TOOLS



1/4" Drive Ideal for assembly and servicing of small precision mechanisms associated with electrical, electronic, ignition and refrigeration work. Sockets have a knurl feature to give a high grip which is essential for a quick tool change when your hands are greasy/oily. The 12 point bi-hexagon side drive design will give a higher torque than normal sockets, grip worn nuts and will not round off existing nuts. Manufactured from chrome vanadium and are fully chrome plated with an aluminium free mirror finish. Chamfered leading edge ensures easy fastener location. Sockets manufactured to: **ANSI B107.5M: 1987, ANSI B107.1: 1978 & BS 4006 : 1992.** Accessories manufactured to: **ANSI B107.10M : 1982 & BS 4006 : 1992.**



TSD46M - 46 Piece Metric Set

Standard & Deep Sockets with Screwdriver Bits

Sockets: 4, 4.5, 5, 5.5, 6, 7, 8, 9, 10, 11, 12, 13, 14mm.
Deep Sockets: 4, 4.5, 5, 5.5, 6, 7, 8, 9, 10, 11, 12, 13, 14mm.
Screwdriver Bits: Slotted 4, 5.5, 7mm.
Crosspoint No.1, No.2, No.3. **Hex** 3, 4, 5, 6, 8mm.
Accessories: sliding T-handle, ratchet handle, extension bar 50 and 150mm, wobble extension 100 and 250mm, universal joint, jointed swivel handle 150mm, spinner handle.



Number of Pieces	Weight each	Order Code	Price/1 TB
46	3.20kg	KEN-582-4897K	6431.00

TSD82MA - 82 Piece Metric & Inch

Standard & Deep Sockets with Screwdriver Bits

Sockets: 4, 4.5, 5, 5.5, 6, 7, 8, 9, 10, 11, 12, 13, 14mm. 3/16", 7/32", 1/4", 5/16", 11/32", 3/8", 7/16", 1/2" AF.
 0, 1, 2, 3, 4, 5, 6BA.
Deep Sockets: 4, 4.5, 5, 5.5, 6, 7, 8, 9, 10, 11, 12, 13, 14mm.
Screwdriver Bits: Slotted 4, 5.5, 7mm. **Crosspoint** No.1, No.2, No.3, No.4. **Hex** 3, 4, 5, 6, 8mm. 1/8", 5/32", 3/16", 7/32", 1/4", 5/16" AF. **TZ** T6, T7, T8, T9, T10, T15, T20, T25, T27, T30, T40.
Accessories: sliding T-handle, ratchet handle, 100, 150 and 250mm extension bars, 50 and 150mm wobble extension, 150mm flexible extension, square male adaptor 3/8", 150mm jointed swivel handle, spinner handle, universal joint.



Number of Pieces	Weight each	Order Code	Price/1 TB
82	3.80kg	KEN-582-4896K	8644.00

TS46MA - 46 Piece Metric & Inch

Standard Sockets with Screwdriver Bits

Sockets: 4, 4.5, 5, 5.5, 6, 7, 8, 9, 10, 11, 12, 13, 14mm.
AF Sockets: 3/16", 7/32", 1/4", 5/16", 11/32", 3/8", 7/16", 1/2".
Screwdriver Bits: Slotted 4, 5.5mm. **Crosspoint** No.2, No.3. **Hex** 3, 4, 5, 6, 8mm. **Hex** 1/8", 5/32", 3/16", 7/32", 1/4", 5/16" AF.
Accessories: sliding T-handle, ratchet handle, wobble extension 50 and 150mm, extension bars 100 and 250mm, universal joint, jointed swivel handle 150mm, flexible extension 150mm, spinner handle.

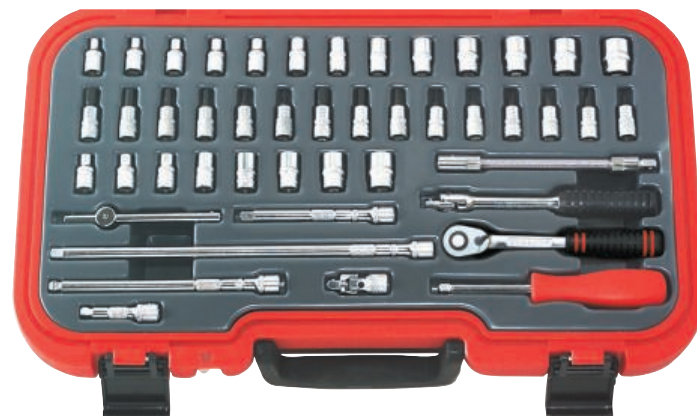

Number of Pieces	Weight each	Order Code	Price/1 TB
46	3.00kg	KEN-582-4898K	6255.00

MT50M - 50 Piece Metric

Standard Sockets:

4, 4.5, 5, 5.5, 6, 7, 8, 9, 10, 11, 12, 13mm.
Accessories: ratchet handle, sliding T-handle, 50, 150 and 250mm extension bars, 100mm wobble extension, 150mm flexible extension, universal joint, 150mm jointed swivel handle, spinner handle.
Sockets: 8, 9, 10, 11, 12, 13, 14, 15, 16, 17, 18, 19, 20, 21, 22, 23, 24, 27, 30, 32, 36mm.
Accessories: quick release ratchet handle, universal joint, sliding T-handle, 375mm swivel handle, 75 and 250mm extension bars, 150mm wobble extensions.



Number of Pieces	Weight each	Order Code	Price/1 TB
50	8.10kg	KEN-582-4899K	13255.00

HAND TOOLS

GROUP 582 SOCKETS SETS - 3/8" SQUARE DRIVE



3/8" Drive Used in the automotive and aerospace industries. The weight to strength ratio ensures the reliability and accessibility that is so important on this type of production. All Kennedy professional sockets have a double knurl feature to give a high grip which is essential for a quick tool change when your hands are greasy/oily. The 12 point bi-hexagon side drive design will give a higher torque than normal sockets, grip worn nuts and will not round off existing nuts. Manufactured from chrome vanadium and are fully chrome plated with an aluminium free mirror finish. Chamfered leading edge ensures easy fastener location. Sockets manufactured to: **ANSI B107.5M: 1987, ANSI B107.1: 1978 & BS 4006 : 1992.** Accessories manufactured to: **ANSI B107.10M : 1982 & BS 4006 : 1992.**



S30M - 30 Piece Metric with Screwdriver Bits

Sockets: 6, 7, 8, 9, 10, 11, 12, 13, 14, 15, 16, 17, 18, 19, 21 and 22mm.
Spark Plug Sockets: M10 and M14.

Screwdriver Bits: Slotted 5mm, 6mm. **Crosspoint** No.1, 2, 3, 4.

Accessories: ratchet handle, sliding T-handle, swivel handle, universal joint, 75mm extension bar, 150mm wobble extension, parts tray with magnetic insert. Robust fitted case with security padlock hole and cushion grip handle.



Number of Pieces	Weight each	Order Code KEN-582	Price/1 TB
30	3.50kg	-6170K	6831.00

Accessories

Description	Order Code KEN-567	Price/1 TB
Locking Clasps (Pair)	-6000K	140.00

SD25MA - 25 Piece Metric & Inch

Bi-Hex Sockets Deep Sockets: 8, 9, 10, 11, 12, 13, 14, 15, 16, 17, 18, 19, 21, 22mm. 3/8", 7/16", 1/2", 9/16", 5/8", 11/16", 3/4" and 13/16" AF.

Accessories: swivel handle, sliding T-bar, 125mm extension. Parts tray with magnetic insert. Robust fitted case with security padlock hole and cushion grip handle.

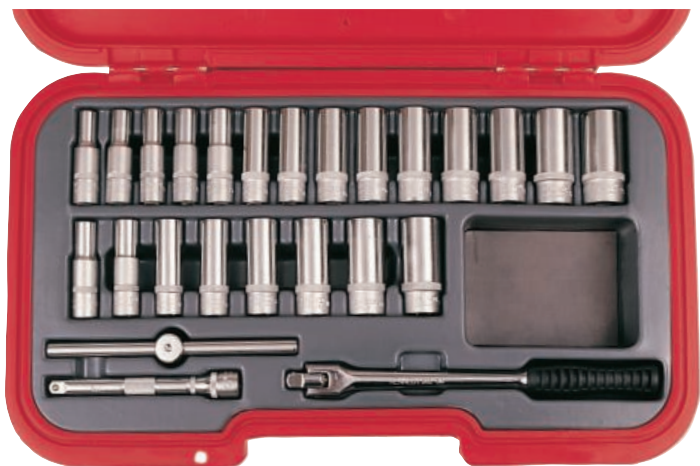

Number of Pieces	Weight each	Order Code KEN-582	Price/1 TB
25	5.50kg	-6190K	5470.00

Accessories

Description	Order Code KEN-567	Price/1 TB
Locking Clasps (Pair)	-6000K	140.00

S40MA - 40 Piece Metric & Inch

Metric & Inch Sockets: 6, 7, 8, 9, 10, 11, 12, 13, 14, 15, 16, 17, 18, 19, 20, 21, 22mm. 1/4", 5/16", 11/32", 3/8", 7/16", 1/2", 9/16", 5/8", 11/16", 3/4", 13/16" and 7/8" AF.

Spark Plug Sockets: M10 and M14.

Accessories: ratchet handle, sliding T-handle, universal joint, 75 and 150mm extension bars, 150mm wobble extension, 1/4" and 1/2" male adaptors, 1/4" hexagon coupler. Robust fitted case with security padlock hole and cushion grip handle.



Number of Pieces	Weight each	Order Code KEN-582	Price/1 TB
40	3.60kg	-6175K	7186.00

Accessories

Description	Order Code KEN-567	Price/1 TB
Locking Clasps (Pair)	-6000K	140.00

SSD50M - 50 Piece Metric with Screwdriver Bits

Standard & Deep Sockets
Standard: 6, 7, 8, 9, 10, 11, 12, 13, 14, 15, 16, 17, 18, 19, 20, 21 and 22mm.
Deep: 10, 11, 12, 13, 14, 15, 17, 19 and 22mm.

Screwdriver Bits: Slotted 5, 5.5 and 6.5mm. **Crosspoint** No.1, 2, 3, 4. **Hex** 3, 4, 5, 6, 8 and 10mm.

Accessories: ratchet handle, sliding T-handle, spinner handle, swivel handle, universal joint, 125 and 250mm extensions, 250mm wobble extensions, 1/4" and 1/2" male adaptors, 1/4" hex bit coupler. Robust fitted case with security padlock hole and cushion grip handle.



Number of Pieces	Weight each	Order Code KEN-582	Price/1 TB
50	4.75kg	-6180K	9688.00

Accessories

Description	Order Code KEN-567	Price/1 TB
Locking Clasps (Pair)	-6000K	140.00

HAND TOOLS



KENNEDY PROFESSIONAL SS90MAW - 90 Piece Metric, Inch & Whitworth with Screwdriver Bits

Sockets: 6, 7, 8, 9, 10, 11, 12, 13, 14, 15, 16, 17, 18, 19, 20, 21, 22mm.
 1/4", 5/16", 11/32", 3/8", 7/16", 1/2", 9/16", 5/8", 11/16", 3/4", 13/16" and 7/8" AF. 1/8", 3/16", 1/4", 5/16", 3/8", 7/16" and 1/2" Whit.

Screwdriver Bits:

Slotted 3/16", 7/32" and 1/4". **Crosspoint** No.1, 2, 3, 4. **PZ** No.1, No.2, No.3. **TX** T6, T7, T8, T9, T10, T15, T20, T25, T27, T30, T40, T45, T50. **Hex** 3, 4, 5, 6, 8, 10mm. 1/8", 5/32", 3/16", 7/32", 1/4", 5/16" and 3/8" AF.

Spark Plug Sockets: M10 and M14.

Accessories: ratchet handle, sliding T-handle, spinner handle, swivel handle, universal joint. 75, 125, 150, 250, 300 and 450mm extensions, 150 and 250mm wobble extensions, 1/4" and 1/2" male adaptors, 1/4" hexagon coupler. Robust fitted case with security padlock hole and cushion grip handle.

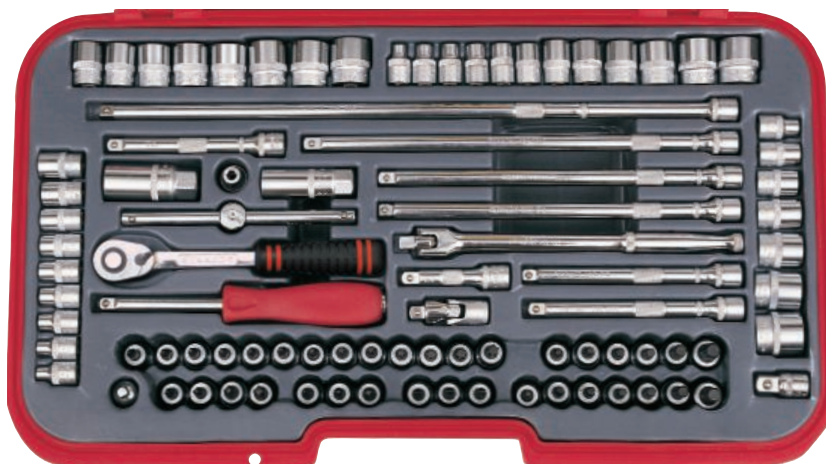

Number of Pieces	Weight each	Order Code KEN-582	Price/1 TB	Accessories	Order Code KEN-567	Price/1 TB
90	8.70kg	-6185K	17212.00	Locking Clasps (pr)	-6000K	140.00

YAMOTO INDUSTRIAL SOCKET SETS

3/8" Square Drive Manufactured from industrial quality chrome vanadium steel with high polished corrosion resistant finish. The high strength to weight ratio ensures the reliability and accessibility that is necessary for use in the automotive, assembly, service and maintenance industries.

The bi-hexagonal design allows a higher torque to be applied and will not round off existing nuts.

Sockets manufactured to: **ANSI B107.5M:1987**. Accessories manufactured to: **ANSI B107.10M:1982**.



55 Piece Metric Standard & Deep Socket Set with Screwdriver Bits

3/8" Drive Bi-Hex Sockets Standard & Deep Sockets:

Sockets: 6, 7, 8, 9, 10, 11, 12, 13, 14, 15, 16, 17, 18, 19, 20, 21, and 22mm.

Deep Sockets: 10, 11, 12, 13, 14, 15, 17, 19 and 22mm.

Spark Plug Sockets: M10 and M14.

Screwdriver Bits: Phillips No.1, 2, 3.

Slotted 5, 6mm.

TX T10, T15, T20, T30, T40, T50.

Hex 3, 4, 5, 6, 8, 10mm. Hex bit coupler.

Accessories: Lever type ratchet, sliding T-handle, swivel handle, spinner handle, universal joint, 150 and 300mm extension bars, 250mm wobble extension. Fitted case with cushioned handle, snap shut clasp and padlock hole.



Number of Pieces	Weight each	Order Code YMT-582	Price/1 TB	Accessories	Order Code YMT-593	Price/1 TB
55	6.00kg	-6180K	7571.00	Replacement Case	-2870K	1545.00

55 Piece Metric & Inch

3/8" Drive Bi-Hex Sockets Standard & Deep Sockets

Sockets: 6, 7, 8, 9, 10, 11, 12, 13, 14, 15, 16, 17, 18, 19, 20, 21 and 22mm.

1/4", 5/16", 11/32", 3/8", 7/16", 1/2", 9/16", 5/8", 11/16", 3/4", 13/16", and 7/8" AF.

Deep Sockets: 10, 11, 12, 13, 14, 15, 17, 19, 22mm. 3/8", 7/16", 1/2", 9/16", 5/8", 11/16", 3/4" and 13/16" AF.

Spark Plug Sockets: M10 and M14.

Accessories: lever type ratchet, sliding T-handle, universal joint, 150 and 300mm extension bars, 250mm wobble extension, 1/4" hex bit coupler. Fitted case with cushioned handle, snap shut clasp and padlock hole.



Number of Pieces	Weight each	Order Code YMT-582	Price/1 TB	Accessories	Order Code YMT-593	Price/1 TB
55	5.70kg	-6200K	7209.00	Replacement Case	-2880K	1545.00

GROUP 582 SOCKET SETS - 3/8" & 1/2" SQUARE DRIVE

YAMOTO
INDUSTRIAL SOCKET SETS

1/2" Square Drive Manufactured from industrial quality chrome vanadium steel with corrosion resistant high polish aluminium free mirror finish. The 12 point bi-hexagonal side drive sockets allow higher torques to be applied to nuts without damage and grip worn nuts. The strength and robust design of 1/2" drive sockets make them suitable for the heavy use encountered in agriculture, service and maintenance industries.



Sockets manufactured to: **ANSI B107.5M:1987**. Accessories manufactured to: **ANSI B107.10M:1982**.

30 Piece Metric

Sockets: 8, 9, 10, 11, 12, 13, 14, 15, 16, 17, 18, 19, 20, 21, 22, 23, 24, 25, 26, 27, 30 and 32mm.

Spark Plug Sockets: M14 and M10.

Accessories: quick release flick lever ratchet with rubber grip, T-handle uni-joint, 75, 125 and 250mm extension bars, robust fitted case with padlock hole and cushion grip handle.



Number of Pieces	Weight each	Order Code	Price/1 TB	Accessories	Order Code	Price/1 TB
30	6.00kg	-7992K	6159.00	Replacement Case	-2910K	1545.00

50 Piece Metric

Sockets: 8, 9, 10, 11, 12, 13, 14, 15, 16, 17, 18, 19, 20, 21, 22, 23, 24, 25, 26, 27, 28, 29, 30, 32, 33 and 36mm.

Screwdriver Bits: Hex 4, 5, 6, 7, 8, 10, 12, 14, 17 and 19mm.

Phillips No.2, No.3, No.4.

Chrome Molybdenum Screwdriver Bits: 9 and 14mm chemically blacked.

Spark Plug Sockets: M14 and M10.

Accessories: black rubber ratchet handle, T-handle, swivel handle, universal joint, 75, 125 and 250mm extension bars. Robust fitted case with magnetic parts tray, padlock hole and cushion grip handle.

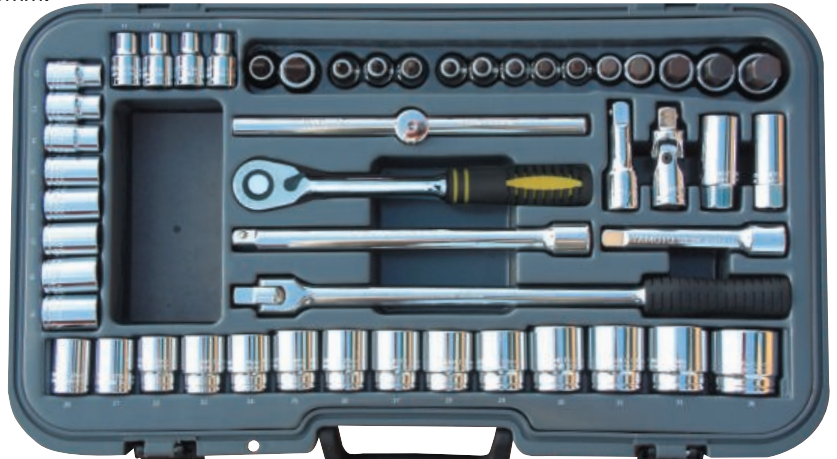

Number of Pieces	Weight each	Order Code	Price/1 TB	Accessories	Order Code	Price/1 TB
50	10.3kg	-7994K	12103.00	Replacement Case	-2920K	2318.00

HAND TOOLS

KENNEDY **Oil Drain Plug Key Set**
QUALITY INDUSTRIAL TOOLING

DPK017

A comprehensive set of quality 3/8" sq. drive oil drain plug keys with tommy bar. Made from satin finished chrome vanadium.

Contents: Male Square: 7mm, 8mm (5/16"), 9mm, (3/8"), 10mm, 11mm, 12mm and 13mm. Female Square: 10mm.

Male Hex: 8, 9, 10, 12, 14 and 17mm.

Male Triangular 10mm.

Tommy bar.



17
PIECES

Product Number	Number of Pieces	Order Code	Price/1 TB
DPK017	17	-1720K	2441.00

Glow Plug Socket Set

GPS060

A comprehensive set of quality glow plug sockets with universal joints for use in awkward areas. Made from satin finished chrome vanadium with a neoprene insert to grip and protect the plug.

Contents: 8, 9, 10, 12, 14 and 16mm.



6
PIECES

Product Number	Number of Pieces	Order Code	Price/1 TB
GPS060	6	-1740K	2228.00

SENATOR QUALITY TOOLING **Combined Socket & Wrench Tool Kit**

The Senator 208 Piece Combined Socket and Wrench Tool Kit comes with a plastic storage case. **Contents:** 1/2" drive sockets: 13 - 32mm. **Drive deep sockets:** 16 to 22mm. **E-Sockets:** 20, 22, 24mm. **Screwdriver bits:** Hex 14mm, TX 70. **Converters:** 1/2" sq. male x 3/8" sq. female. **Accessories:** 125, 250mm extensions bars, 1/2" drive universal joint, T-bar, quick release offset bi-material ratchet handle. **3/8" drive sockets:** 10 - 19mm. **Deep sockets:** 10 - 15mm. **Spark plug sockets:** 16, 18, 21mm. **E-Sockets:** 10 - 18mm. **Screwdriver bits:** Slotted 6 - 12. PZ No. 1, 2, 3. Crosspoint No.1, 2, 3, 4. Hex 6 - 12mm. TX 40 - 60. Tamper proof TX 40 - 60. Spline 5, 6, 8. **Converters:** 3/8" sq. female x 5/16" hex drive, 3/8" sq. female x 1/4" sq. male. **Accessories:** 75mm extension bar, universal joint, quick release offset bi-material ratchet handle. **1/4" drive sockets:** 4 - 14mm. **Deep sockets:** 4 - 10mm. **E-Sockets:** 4 - 8mm. **Screwdriver bits:** Slotted 4 - 7mm. PZ No.0, 1, 2. Crosspoint No.0, 1, 2, TX 8 - 30. Tamper-proof TX 8 - 30. Hex 3 - 6mm. **Converters:** 1/4" sq. female x 1/4" hex drive. **Accessories:** 50, 100mm extension bars, universal joint, T-bar, nut spinner handle, quick release offset bi-material ratchet handle. **Combination spanners:** 8 - 19mm. **Hex key wrenches:** 1.5, 2.0, 2.5mm. **Magnetic bit:** 1/4" hex driver. **Screwdriver bits:** 1/4" hex driver. **Converter:** 2x 1/4" sq. male, **Slotted** 2x 3.5, 4mm 1x 5.5, 6.5, 8mm, **PZ** No.1, 2, 3, **Crosspoint** 2x No.0, 1, 2, 3, TX 10, 15, 20, 25, 27, 30, 40, **Tri-Wing** No.1, 2, 3, 4, **Square** 1, 2, 3, hex 2, 3, 4, 5, 6, 7mm.



**208
PIECES**

Number of Pieces	Weight each	Order Code	Price/1 TB
208	10.7kg	SEN-582 -9000K	10079.00

SE24M - 24 Piece Metric

Sockets: 10, 11, 12, 13, 14, 15, 16, 17, 18, 19, 20, 21, 22, 23, 24, 27, 30, and 32mm.

Accessories: ratchet handle, T-handle, speed brace, universal joint, 125 and 250mm extension bars.

**24
PIECES**

SE24MA - 24 Piece Metric & Inch

As for SE24M except for:

Sockets: 10, 11, 12, 13, 14, 16, 17, 19, 20 and 22mm.

3/8", 7/16", 1/2", 9/16", 5/8", 3/4", 7/8" and 15/16" AF.

**HOME
IMPROVER**



Model Number	Number of Pieces	Weight each	Order Code	Price/1 TB
SE24M	24	4.00kg	SEN-582 -0120K	3554.00
SE24MA	24	4.00kg	-0160K	3904.00

SE42MAW - 42 Piece Metric, Inch & Whitworth

Sockets: 10, 11, 12, 13, 14, 15, 17, 19, 20, 21, 22, 24 and 27mm. 3/8", 7/16", 1/2", 9/16", 5/8", 11/16", 3/4", 13/16", 7/8", 15/16", 1", 1 1/16", 1 1/4" AF. 1/8", 3/16", 1/4", 5/16", 3/8", 7/16", 1/2", 9/16" and 5/8" BSW.

Spark Plug Socket: M14 (21mm).

Accessories: ratchet, T-handle, brace, universal joint, 125 and 250mm extension bars.

**42
PIECES**



Number of Pieces	Weight each	Order Code	Price/1 TB
42	6.15kg	SEN-582 -0180K	5867.00

KENNEDY QUALITY INDUSTRIAL TOOLING **Oxygen 'EGO', 'O2', 'Lambda' Sensor Socket Set**

Three piece universal set. Essential for servicing today's computer-controlled vehicle systems. Easily removes exhaust gas oxygen sensors (known as 'EGO', 'O2' or 'Lambda' sensors), vacuum switches and pressure switches. Also suitable for diesel injectors found on Mitsubishi, Nissan, Opel, Vauxhall and VW vehicles. Made from heat treated cast steel.



Set contains:

22mm (7/8") hex, 1/2" square drive socket with 7.5mm side slot for sensor wire clearance. Socket has 22mm hex for use with a spanner. **Overall length:** 80mm.
22mm (7/8") hex, crow's foot style wrench, 1/2" square drive (double square for easy access). With full length 11mm slot for total clearance of switch/sensor wire.
22mm (7/8") hex, crow's foot style wrench, 3/8" square drive. With full length 8.6mm slot for total clearance of switch/sensor wire.

Description	Order Code	Price/1 TB
Sensor Socket Set	KEN-503 -8020K	1494.00

**3
PIECES**

Oil Filter Cap Wrench Set

Cap type filter wrenches made from chrome vanadium with a satin finish. Use with 3/8" or 1/2" square drive wrenches to remove paper cartridge style oil filters.

Contents: 24, 27, 30, 32, 36, 38mm and 1/2" - 3/8" adaptor.



**7
PIECES**

Diameter (mm)	Weight each	Order Code	Price/1 TB
60 - 140	430g	KEN-503 -1790K	2653.00

GROUP 582 SOCKETS SETS - 1/2" SQUARE DRIVE



1/2" Square Drive The most popular drive size used in the service and maintenance industries. This popularity is due to the strength and robust nature of 1/2" drive. All Kennedy Professional sockets have a knurl feature to give a high grip which is essential for a quick tool change when your hands are greasy/oily. The 12 point bi-hexagon side drive design will give a higher torque than normal sockets, grip worn nuts and will not round off existing nuts. Manufactured from chrome vanadium and are fully chrome plated with an aluminium free mirror finish. Chamfered leading edge ensures easy fastener location. Sockets manufactured to: **ANSI B107.5M : 1987, ANSI B107.1 : 1978 & BS 4006 : 1992.** Accessories manufactured to: **ANSI B107.10M : 1982 & BS 4006 : 1992.**



M20M - 20 Piece Metric



Sockets: 10, 11, 12, 13, 14, 15, 17, 19, 22, 24, 27, 30 and 32mm.

Spark Plug Sockets: M10 and M14.

Accessories: quick release ratchet handle, sliding T-handle, universal joint, 125 and 250mm extension bars. Robust fitted case with security padlock hole and cushion grip handle.



**20
PIECES**

Accessories

Number of Pieces	Weight each	Order Code	Price/1 TB
20	4.90kg	-7983K	8386.00

Description	Order Code	Price/1 TB
Locking Clasps (Pair)	-6000K	140.00

M25M - 25 Piece Metric



Sockets: 8, 9, 10, 11, 12, 13, 14, 15, 16, 17, 18, 19, 22, 24, 27, 30 and 32mm.

Spark Plug Sockets: M10 and M14.

Accessories: quick release ratchet handle, sliding T-handle, universal joint, 75, 125 and 250mm extension bars. Robust fitted case with security padlock hole and cushion grip handle.



**25
PIECES**

Accessories

Number of Pieces	Weight each	Order Code	Price/1 TB
25	4.90kg	-7985K	9122.00

Description	Order Code	Price/1 TB
Locking Clasps (Pair)	-6000K	140.00

M30MSH - 30 Piece Metric - Single Hexagon



Sockets: 8, 9, 10, 11, 12, 13, 14, 15, 16, 17, 18, 19, 20, 21, 22, 23, 24, 25, 26, 27, 30 and 32mm.

Spark Plug Sockets: M10 and M14.

Accessories: quick release ratchet handle, universal joint, sliding T-handle, 75, 125 and 250mm extension bars. Supplied in a fitted impact-resistant plastic carry case with a cushioned handle, snap-shut clasps and padlock hasp hole.



**30
PIECES**

Number of Pieces	Weight each	Order Code	Price/1 TB
30	5.55kg	-7940K	8175.00

HAND TOOLS



1/2" Square Drive The most popular drive size used in the service and maintenance industries. This popularity is due to the strength and robust nature of 1/2" drive. All Kennedy Professional sockets have a knurl feature to give a high grip which is essential for a quick tool change when your hands are greasy/oily.



The 12 point bi-hexagon side drive design will give a higher torque than normal sockets, grip worn nuts and will not round off existing nuts. Manufactured from chrome vanadium and are fully chrome plated with an aluminium free mirror finish. Chamfered leading edge ensures easy fastener location. Sockets manufactured to: **ANSI B107.5M : 1987, ANSI B107.1 : 1978 & BS 4006 : 1992.** Accessories manufactured to: **ANSI B107.10M : 1982 & BS 4006 : 1992.**

M30M - 30 Piece Metric

Sockets: 8, 9, 10, 11, 12, 13, 14, 15, 16, 17, 18, 19, 20, 21, 22, 23, 24, 25, 26, 27, 30 and 32mm.

Spark Plug Sockets: M10 and M14.

Accessories: quick release ratchet handle, sliding T-handle, universal joint, 75, 125 and 250mm extension bars. Robust fitted case with security padlock hole and cushion grip handle.



**30
PIECES**

Number of Pieces	Weight each	Order Code KEN-582	Price/1 TB
30	5.50kg	-7991K	7880.00

Accessories	Order Code KEN-567	Price/1 TB
Locking Clasps (Pr)	-6000K	140.00

M30MA - 30 Piece Metric & Inch

Sockets: 8, 9, 10, 11, 12, 13, 14, 15, 16, 17, 18, 19, 22 and 24mm. 3/8", 7/16", 1/2", 9/16", 5/8", 11/16", 3/4" and 7/8" AF.

Spark Plug Sockets: M10 and M14.

Accessories: quick release ratchet handle, sliding T-handle, universal joint, 75, 125 and 250mm extension bars. Robust fitted case with security padlock hole and cushion grip handle.



**30
PIECES**

Number of Pieces	Weight each	Order Code KEN-582	Price/1 TB
30	5.30kg	-7987K	9265.00

Accessories	Order Code KEN-567	Price/1 TB
Locking Clasps (Pr)	-6000K	140.00

MD30MA - 30 Piece Deep Metric & Inch

Sockets: 10, 11, 12, 13, 14, 15, 16, 17, 18, 19, 21, 22, 24, 26, 27, 30 and 32mm. 1/2", 9/16", 5/8", 11/16", 3/4", 13/16", 7/8", 15/16", 1", 1 1/8" and 1 1/4" AF.

Accessories: offset handle, swivel handle. Parts tray with magnetic insert. Robust fitted case with security padlock hole and cushion grip handle.



**30
PIECES**

Number of Pieces	Weight each	Order Code KEN-582	Price/1 TB
30	12.2kg	-7997K	9693.00

Accessories	Order Code KEN-567	Price/1 TB
Locking Clasps (Pr)	-6000K	140.00

PRODUCTS ARE ONLY AVAILABLE VIA YOUR DISTRIBUTOR

HAND TOOLS

GROUP 582 SOCKETS SETS - 1/2" SQUARE DRIVE

KENNEDY PROFESSIONAL MS50M - 50 Piece Metric with Driver Bits

Sockets: 8, 9, 10, 11, 12, 13, 14, 15, 16, 17, 18, 19, 20, 21, 22, 23, 24, 25, 26, 27, 28, 29, 30, 32, 33 and 36mm.

Screwdriver Bits: Crosspoint No.2, No.3, No.4. Hex 4, 5, 6, 7, 8, 10, 12, 14, 17 and 19mm. **Screwdriver Bits:** 9 and 14mm

Spark Plug Sockets: M10 and M14.

Accessories: Quick release ratchet handle, sliding T-handle, swivel handle, universal joint 75, 125 and 250mm extension bars.

Parts tray with magnetic insert. Robust fitted case with security padlock hole and cushion grip handle.

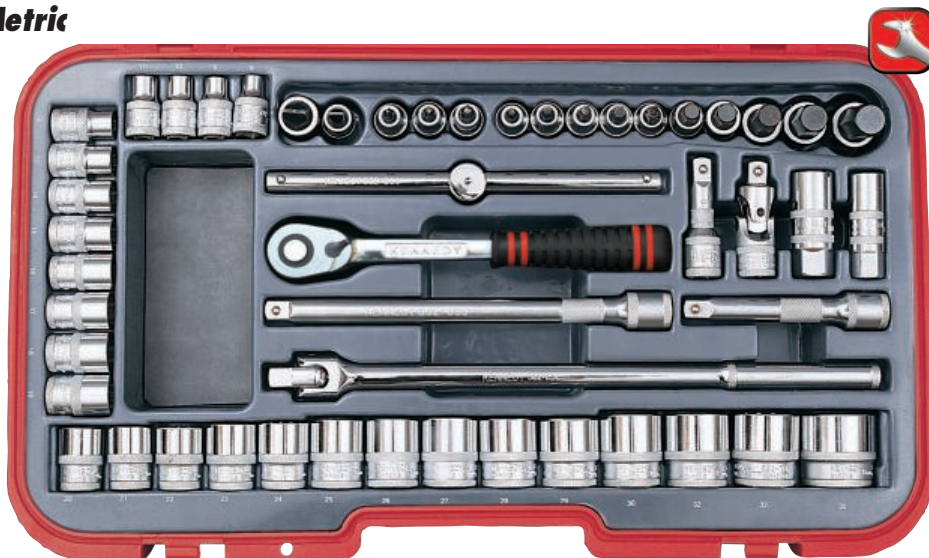

**50
PIECES**

Number of Pieces	Weight each	Order Code KEN-582	Price/1 TB	Accessories	Order Code KEN-567	Price/1 TB
50	9.85kg	-7993K	15399.00	Locking Clasps (Pr)	-6000K	140.00

M70MAW - 70 Piece Metric, Inch & Whitworth

Sockets: 8, 9, 10, 11, 12, 13, 14, 15, 16, 17, 18, 19, 20, 21, 22, 23, 24, 25, 26, 27, 28, 29, 30, 32, 33 and 36mm. 5/16", 3/8", 7/16", 1/2", 9/16", 19/32", 5/8", 11/16", 3/4", 13/16", 7/8", 15/16", 1", 1 1/16", 1 1/8", 1 3/16" and 1 1/4" AF. 1/8", 3/16", 1/4", 5/16", 3/8", 7/16", 1/2", 9/16", 5/8", 11/16" and 3/4" Whit.

Hex Bit Adaptors: 1/4" and 5/16".

Spark Plug Sockets: M10 and M14.

Convertors: 1/2" sq. female x 3/4" sq. male, 1/2" sq. female x 3/8" sq. male.

Accessories: quick release ratchet handle, sliding T-handle, swivel handle, universal joint, 75, 125, 250, and 450mm extension bars, 125 and 250mm wobble extensions. Robust fitted case with security padlock hole and cushion grip handle.

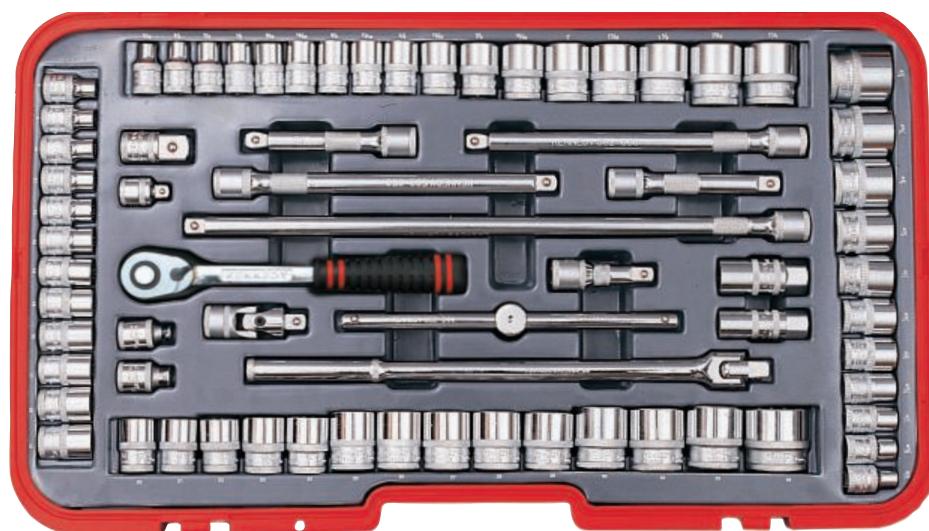

**70
PIECES**

Number of Pieces	Weight each	Order Code KEN-582	Price/1 TB	Accessories	Order Code KEN-567	Price/1 TB
70	12.2kg	-7995K	17150.00	Locking Clasps (Pr)	-6000K	140.00

YAMOTO INDUSTRIAL SOCKET SETS

1/2" Square Drive Manufactured from industrial quality chrome vanadium steel with corrosion resistant high polish mirror finish, aluminium-free to ensure non-sparking. The 12 point bi-hexagonal side drive sockets allow higher torques to be applied to nuts without damage and to grip worn nuts. The strength and robust design of 1/2" drive make them suitable for the heavy use encountered in agriculture, service and maintenance industries. Sockets manufactured to: **ANSI B107.5M:1987**. Accessories manufactured to: **ANSI B107.10M:1982**.



50 Piece Metric, Inch & Whitworth

Sockets: 8, 9, 10, 11, 12, 13, 14, 15, 16, 17, 18, 19, 20, 21, 22, 24, 27, 30 and 32mm. 5/16", 3/8", 7/16", 1/2", 9/16", 5/8", 11/16", 3/4", 13/16", 7/8", 15/16", 1", 1 1/16", 1 1/8", 1 1/4" A/F. 3/16", 1/4", 5/16", 3/8", 7/16", 1/2", 9/16" and 5/8" Whit.

Spark Plug Sockets: M14 and M10.

Accessories: quick release flick lever ratchet with rubber grip, T-handle, swivel handle with rubber grip, universal joint, extension bars 125 and 250mm. Robust fitted case with magnetic parts tray, padlock hole and cushion grip handle.

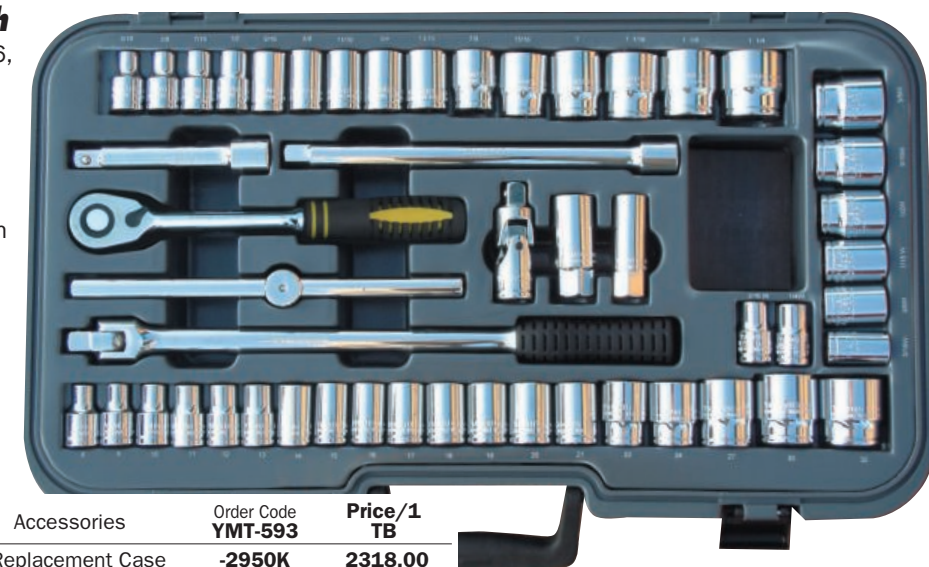

**50
PIECES**

Number of Pieces	Weight each	Order Code YMT-582	Price/1 TB	Accessories	Order Code YMT-593	Price/1 TB
50	9.40kg	-7996K	9373.00	Replacement Case	-2950K	2318.00

HAND TOOLS

SENATOR SH 26MA - 26 Piece
QUALITY TOOLING Metric & Inch

Sockets: 22, 24, 27, 30, 32, 36, 38, 41, 46 and 50mm. 7/8", 15/16", 1", 1 1/8", 1 3/16", 1 5/16", 1 3/8", 1 7/16", 1 5/8", 1 3/4", 1 7/8" and 2" AF.

Accessories: 100 and 200mm extension bars, ratchet handle and T-handle.

**26
PIECES**

HOME IMPROVER

Number of Pieces	Weight each	Order Code	Price/1 TB
26	18.0kg	SEN-582 -0200K	13389.00



KENNEDY PROFESSIONAL

3/4" Drive A heavy duty range designed to cope with the demands of industrial agriculture machinery and heavy plant, static or mobile. All Kennedy Professional sockets have a knurl feature to give a high grip which is essential for a quick tool change when your hands are greasy/oily. The 12 point bi-hexagon side drive design will give a higher torque than normal sockets, grip worn nuts and will not round off existing nuts. Manufactured from chrome vanadium and are fully chrome plated with an aluminium free mirror finish. Chamfered leading edge ensures easy fastener location. Sockets manufactured to: ANSI B107.5M: 1987, ANSI B107.1: 1978 & BS 4006: 1992.

Accessories manufactured to:
ANSI B107.10M: 1982 & BS 4006: 1992.

L22M - 22 Piece Metric

Bi-Hexagon Sockets: 22, 24, 26, 27, 29, 30, 32, 33, 36, 38, 41, 46, 50, 55 and 60mm.

Accessories: lever type ratchet, sliding T-handle, swivel handle, universal joint, 100, 200 and 410mm extension bars. Robust fitted case with security padlock hole and cushion grip handle.

**22
PIECES**

Number of Pieces	Weight each	Order Code	Price/1 TB
22	23.8kg	KEN-582 -8720K	21781.00

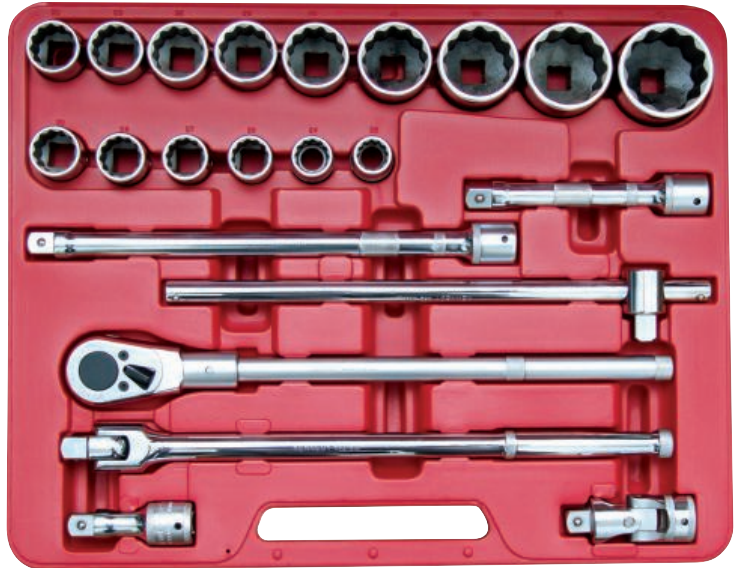

L36MA - 36 Piece Metric & Inch

Bi-Hexagon Sockets: 22, 24, 27, 29, 30, 32, 33, 36, 38, 41, 46, and 50mm. 7/8", 15/16", 1", 1 1/16", 1 1/8", 1 3/16", 1 1/4", 1 5/16", 1 3/8", 1 7/16", 1 1/2", 1 5/8", 1 11/16", 1 3/4", 1 13/16", 1 7/8" and 2" AF.

Accessories: ratcheting head with 550mm universal handle, sliding T-handle, 1" to 3/4" converter, 200 and 400mm extension bars.

**36
PIECES**

Number of Pieces	Weight each	Order Code	Price/1 TB
36	29.3kg	KEN-582 -8740K	25865.00

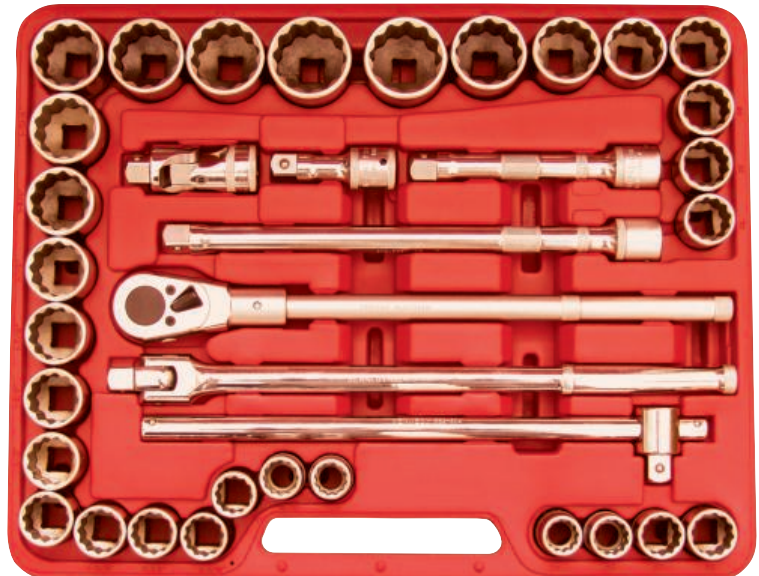

15 Piece Metric Socket Set

Sockets: 36, 41, 46, 50, 55, 60, 65, 70, 75 and 80mm.

Accessories: ratchet and sliding T-handle, 550mm universal handle, 200 and 400mm extension bars.

**15
PIECES**

Number of Pieces	Weight each	Order Code	Price/1 TB
15	18.0kg	KEN-582 -9470K	37356.00



HAND TOOLS



Chrome Molybdenum Impact Sockets & Accessories

Manufactured from high quality chrome molybdenum steel. Black oxidised finish with permanent laser etched markings.

1/4" Drive Metric, Standard Length, 6-Point
Conform to: **DIN 3129.**

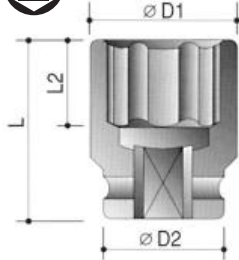

Style A Style B

Socket (mm)	Style	Dimensions (mm)				Weight each	Order Code KEN-583	Price/1 TB
		D2	D1	L2	L			
6	A	13.0	10.0	6.0	23.0	15g	-0640K	122.00
7	A	13.0	11.3	6.0	23.0	15g	-0650K	122.00
8	A	13.0	12.5	7.0	23.0	15g	-0660K	122.00
9	A	13.0	13.8	7.0	23.0	15g	-0670K	122.00
10	A	13.0	15.0	7.0	23.0	17g	-0680K	122.00
11	A	13.0	16.3	8.0	23.0	20g	-0690K	122.00
12	B	13.0	17.0	8.0	23.0	17g	-0700K	122.00
13	B	13.0	18.8	8.0	23.0	22g	-0710K	137.00
14	B	13.0	20.0	8.0	23.0	20g	-0720K	137.00

1/4" Drive Reducers & Adaptors

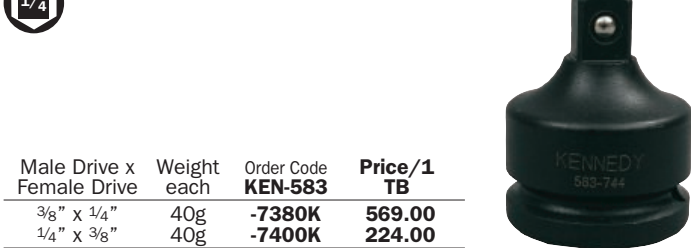

Male Drive x Female Drive	Weight each	Order Code KEN-583	Price/1 TB
3/8" x 1/4"	40g	-7380K	569.00
1/4" x 3/8"	40g	-7400K	224.00

3/8" Drive Metric, Standard Length, 6-Point
Conform to: **DIN 3129.**

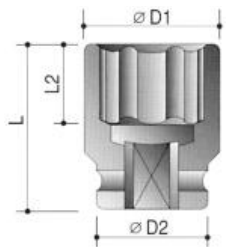

Style A Style B Style C

Socket (mm)	Style	Dimensions (mm)				Weight each	Order Code KEN-583	Price/1 TB
		D2	D1	L2	L			
6	A	19.0	11.0	4.0	30.0	35g	-1240K	140.00
7	A	19.0	12.5	8.0	30.0	40g	-1250K	140.00
8	A	19.0	13.8	8.0	30.0	40g	-1260K	140.00
9	A	19.0	15.0	8.0	30.0	40g	-1270K	140.00
10	A	19.0	16.0	8.0	30.0	40g	-1280K	140.00
11	A	19.0	17.5	9.0	30.0	40g	-1290K	140.00
12	B	19.0	19.0	9.0	30.0	40g	-1300K	140.00
13	A	22.0	20.0	9.0	30.0	55g	-1310K	140.00
14	A	22.0	21.0	9.0	30.0	55g	-1320K	140.00
15	B	22.0	22.0	11.0	30.0	55g	-1330K	140.00
16	C	22.0	24.0	11.0	30.0	60g	-1340K	140.00
17	C	22.0	25.0	11.0	30.0	60g	-1350K	140.00
18	C	22.0	26.0	11.0	30.0	60g	-1360K	140.00
19	C	22.0	27.5	11.0	30.0	70g	-1370K	140.00
20	C	22.0	28.0	12.0	30.0	70g	-1380K	150.00
21	C	22.0	30.0	13.0	30.0	70g	-1390K	150.00
22	C	24.0	32.0	13.0	30.0	85g	-1400K	165.00

3/8" Drive Reducers & Adaptors

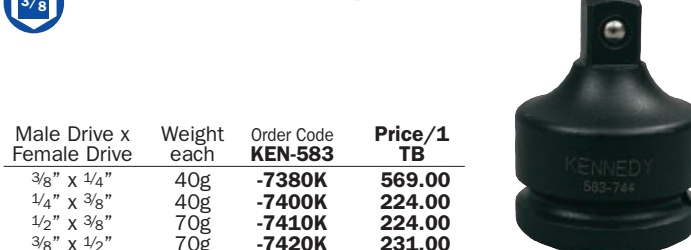

Male Drive x Female Drive	Weight each	Order Code KEN-583	Price/1 TB
3/8" x 1/4"	40g	-7380K	569.00
1/4" x 3/8"	40g	-7400K	224.00
1/2" x 3/8"	70g	-7410K	224.00
3/8" x 1/2"	70g	-7420K	231.00

1/4" Drive Extension Bars



Length (mm)	Weight each	Order Code KEN-583	Price/1 TB
50 (2")	24g	-7490K	215.00
100 (4")	43g	-7495K	235.00

3/8" Drive Inch Size, Standard Length, 6-Point
Conform to: **SAE, USA Federal Standard GGG-W-660A.**

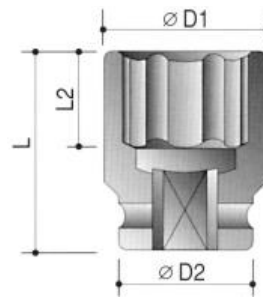

Style A Style B

Socket (inch)	Style	Dimensions (mm)				Weight each	Order Code KEN-583	Price/1 TB
		D2	D1	L2	L			
1/4"	A	19.0	11.0	4.0	30.0	30g	-1430K	233.00
5/16"	A	19.0	12.5	8.0	30.0	30g	-1440K	233.00
3/8"	A	19.0	14.5	8.0	30.0	35g	-1460K	233.00
7/16"	A	19.0	17.0	9.0	30.0	35g	-1470K	233.00
1/2"	B	19.0	19.0	9.0	30.0	35g	-1480K	233.00
9/16"	B	20.0	20.0	9.0	30.0	40g	-1490K	233.00
5/8"	B	24.0	24.0	11.0	30.0	70g	-1500K	233.00
11/16"	B	24.0	24.0	11.0	30.0	70g	-1510K	280.00
3/4"	B	26.0	26.0	11.0	30.0	80g	-1520K	280.00

3/8" Drive Extension Bars



Length (mm)	Weight each	Order Code KEN-583	Price/1 TB
50 (2")	24g	-7500K	225.00
100 (4")	43g	-7510K	305.00



IMPACT SOCKETS - 3/8" SQUARE DRIVE



Hex Driver Impact Sockets 3/8" Sq. Dr.

3/8 Hexagon sizes: 4, 5, 6, 7, 8, 10 and 12mm.
Conforms to **DIN 3129**.



Size (mm)	Overall Length	Weight each	Order Code KEN-583	Price/1 TB
4	50mm	40g	-1960K	293.00
5	50mm	45g	-1962K	293.00
6	50mm	45g	-1964K	293.00
7	50mm	45g	-1966K	293.00
8	50mm	50g	-1968K	293.00
10	50mm	60g	-1970K	293.00
12	50mm	70g	-1972K	293.00

7 Piece Set
Contents as above.

7 PIECES



Number of Pieces	Weight each	Order Code KEN-583	Price/1 TB
7	550g	-9820K	1797.00

Impact Socket Set

3/8 Standard length: metric 6, 7, 8, 9, 10, 11, 12, 13, 14, 15, 16, 17, 18, 19, 20, 21 and 22mm.

Standard length: A/F 1/4", 5/16", 3/8", 7/16", 1/2", 9/16", 5/8", 11/16" and 3/4".

Deep metric: 7, 8, 10, 11, 12, 13, 14, 15, 16, 17, 18, 19 and 21mm.

39 PIECES



Number of Pieces	Weight each	Order Code KEN-583	Price/1 TB
39	3.50kg	-9810K	5485.00

KENNEDY Impact Sockets
QUALITY INDUSTRIAL TOOLING

Manufactured from high quality chrome molybdenum steel. Black oxidised finish with permanent laser etched markings.

3/8 Drive Metric, Deep Length, 6-Point
Conform to: **DIN 3129**.

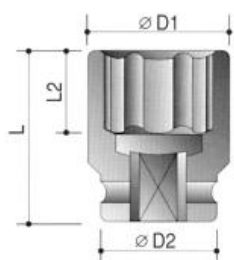

Socket (mm)	Style	Dimensions (mm)				Weight each	Order Code KEN-583	Price/1 TB
		D2	D1	L2	L			
7	A	19.0	12.5	12.0	65.0	75g	-1700K	210.00
8	A	19.0	13.8	12.0	65.0	80g	-1710K	210.00
10	A	19.0	16.0	12.0	65.0	80g	-1720K	210.00
11	A	19.0	17.5	25.0	65.0	80g	-1730K	210.00
12	B	19.0	19.0	25.0	65.0	90g	-1740K	210.00
13	A	22.0	20.0	25.0	65.0	120g	-1750K	211.00
14	A	22.0	21.0	25.0	65.0	120g	-1650K	210.00
15	B	22.0	22.0	25.0	65.0	120g	-1760K	211.00
16	C	22.0	24.0	25.0	65.0	140g	-1770K	233.00
17	C	22.0	25.0	25.0	65.0	140g	-1780K	247.00
18	C	22.0	26.0	25.0	65.0	150g	-1790K	260.00
19	C	22.0	27.5	25.0	65.0	170g	-1800K	272.00
21	C	22.0	30.0	25.0	65.0	185g	-1820K	285.00

3/8 Drive Inch Size, Deep Length, 6-Point
Conform to: **SAE, USA Federal Standard GGG-W-660A**.

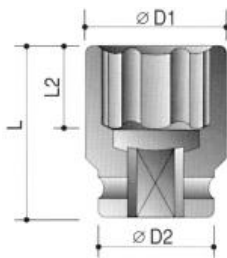

Socket (inch)	Style	Dimensions (mm)				Weight each	Order Code KEN-583	Price/1 TB
		D2	D1	L2	L			
3/8"	A	19.0	14.5	12.0	65.0	80g	-1840K	170.00
7/16"	A	19.0	17.0	25.0	65.0	80g	-1850K	170.00
1/2"	B	19.0	19.0	25.0	65.0	90g	-1860K	170.00
9/16"	B	20.0	20.0	25.0	65.0	100g	-1870K	170.00
3/4"	B	26.0	26.0	25.0	65.0	100g	-1880K	224.00

KENNEDY Square Drive Impact Extractor Sockets
QUALITY INDUSTRIAL TOOLING

Extracts rounded, seized or painted right hand threaded fasteners, the reverse spiral flutes are designed to bite into seized nuts and bolts providing greater grip for extraction. The ejector pin is to drive out the fasteners from sockets, once removed.

Contents: 10, 11, 12, 13, 14, 15, 16, 17 and 19mm extractor sockets plus ejector pin.

10 PIECES

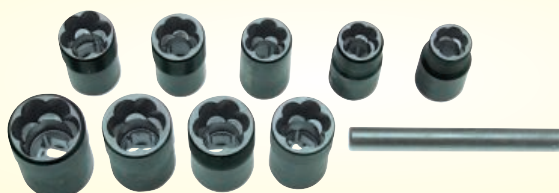

Replacement Ejector Pin

Product Number	Sizes (mm)	Weight each	Order Code KEN-583	Price/1 TB	To Suit			Price/1 TB
					Weight each	Order Code KEN-583	Price/1 TB	
SSE10M	10 - 19	660g	-9800K	2960.00	SSE10M	11g	-7960K	76.00

Individual Extractor Sockets



Size (mm)	Weight each	Order Code KEN-583	Price/1 TB
10	33g	-1980K	290.00
11	34g	-1981K	290.00
12	35g	-1982K	290.00
13	36g	-1983K	290.00
14	37g	-1984K	290.00
15	51g	-1985K	290.00
16	57g	-1986K	290.00
17	68g	-1987K	290.00
19	85g	-1989K	290.00

GROUP 583 IMPACT SOCKETS - 1/2" SQUARE DRIVE

KENNEDY Chrome Molybdenum Impact Sockets
QUALITY INDUSTRIAL TOOLING



Manufactured from high quality chrome molybdenum steel. Black oxidised finish with permanent laser etched markings.

1/2" Drive Metric, Standard Length, 6-Point
 Conform to: **DIN 3129**.

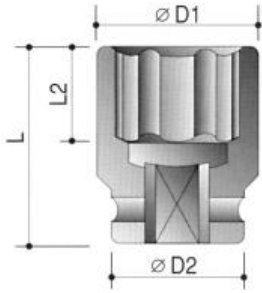

Socket (mm)	Style	Dimensions (mm)				Weight each	Order Code KEN-583	Price/1 TB
		D2	D1	L2	L			
9	A	25.0	12.0	12.0	38.0	90g	-2010K	170.00
10	A	25.0	17.5	12.0	38.0	90g	-2020K	165.00
11	A	25.0	18.7	12.0	38.0	95g	-2030K	165.00
12	A	25.0	20.0	12.0	38.0	100g	-2040K	165.00
13	A	25.0	21.0	12.0	38.0	100g	-2050K	165.00
14	A	25.0	22.5	12.0	38.0	100g	-2060K	165.00
15	A	30.0	23.7	12.0	38.0	140g	-2070K	190.00
16	A	30.0	25.0	12.0	38.0	140g	-2080K	199.00
17	A	30.0	26.0	13.0	38.0	140g	-2090K	199.00
18	A	30.0	27.5	13.0	38.0	140g	-2100K	199.00
19	A	30.0	28.7	13.0	38.0	140g	-2110K	199.00
20	B	30.0	30.0	13.0	38.0	140g	-2120K	210.00
21	B	30.0	30.0	13.0	38.0	130g	-2130K	210.00
22	C	30.0	32.0	13.0	38.0	140g	-2140K	222.00
23	C	30.0	32.0	13.0	38.0	140g	-2150K	235.00
24	C	30.0	35.0	20.0	45.0	180g	-2160K	267.00
26	C	30.0	38.0	22.0	50.0	200g	-2180K	324.00
27	C	30.0	38.7	22.0	50.0	310g	-2190K	336.00
28	C	30.0	40.0	22.0	50.0	230g	-2200K	348.00
30	C	30.0	42.0	22.0	50.0	230g	-2220K	372.00
32	C	30.0	44.0	28.0	50.0	250g	-2230K	380.00
36	C	30.0	49.0	28.0	50.0	250g	-2250K	416.00



1/2" Drive Inch Size, Standard Length, 6-Point
 Conform to: **SAE, USA Federal Standard GGG-W-660A**.

Socket (inch)	Style	Dimensions (mm)				Weight each	Order Code KEN-583	Price/1 TB
		D2	D1	L2	L			
3/8"	A	22.0	16.0	12.0	38.0	70g	-2270K	233.00
7/16"	A	22.0	18.0	12.0	38.0	70g	-2280K	233.00
1/2"	A	22.0	20.0	12.0	38.0	70g	-2290K	233.00
9/16"	A	24.0	22.0	12.0	38.0	80g	-2300K	233.00
5/8"	B	25.0	25.0	12.0	38.0	85g	-2320K	233.00
11/16"	B	26.0	26.0	13.0	38.0	90g	-2330K	239.00
3/4"	B	28.0	28.0	13.0	38.0	100g	-2340K	239.00
13/16"	B	30.0	30.0	13.0	38.0	125g	-2350K	248.00
7/8"	B	32.0	32.0	13.0	38.0	150g	-2360K	248.00
15/16"	B	34.0	34.0	13.0	38.0	170g	-2370K	248.00
1"	B	36.0	36.0	14.0	38.0	190g	-2380K	250.00
1 1/16"	B	38.0	38.0	16.0	40.0	205g	-2390K	250.00
1 1/8"	C	38.0	40.0	16.0	40.0	235g	-2400K	262.00
1 3/16"	C	38.0	42.0	16.0	40.0	255g	-2410K	274.00
1 1/4"	C	38.0	44.0	18.0	40.0	270g	-2420K	287.00

1/2" Drive BSW Size, Standard Length, 6-Point
 Conform to: **SAE, USA Federal Standard GGG-W-660A**.

Socket (BSW)	Style	Dimensions (mm)				Weight each	Order Code KEN-583	Price/1 TB
		D2	D1	L2	L			
5/16"	A	30.0	25.0	12.0	38	140g	-2510K	582.00
3/8"	A	30.0	27.5	13.0	38	140g	-2520K	582.00
7/16"	B	30.0	30.0	13.0	38	140g	-2530K	886.00
1/2"	C	30.0	35.0	20.0	45	190g	-2540K	886.00
9/16"	C	30.0	38.0	22.0	50	210g	-2550K	886.00
5/8"	C	30.0	40.0	22.0	50	305g	-2560K	886.00
11/16"	C	30.0	44.0	28.0	50	305g	-2570K	886.00
3/4"	C	30.0	44.0	28.0	50	305g	-2580K	886.00

Impact Socket Sets

The sockets are manufactured from the highest quality chrome molybdenum steel which is clearly laser etched with the size for easy and rapid identification. Tough, impact-resistant carry case. Conforms to: **Metric DIN 3129, Inch SAE USA Federal Standard GGG-W-660A**.

9 Piece Set - Metric

1/2" Standard length: 10, 12, 13, 14, 17, 19, 24, 27 and 30mm.

**9
PIECES**



Number of Pieces	Weight each	Order Code KEN-583	Price/1 TB
9	1.70kg	-9870K	1982.00

18 Piece Set - Metric

1/2" Standard length: 10, 11, 12, 13, 14, 15, 16, 17, 18, 19, 20, 21, 22, 24, 26, 27, 30 and 32mm.

**18
PIECES**



Number of Pieces	Weight each	Order Code KEN-583	Price/1 TB
18	3.40kg	-9860K	3919.00

HAND TOOLS

KENNEDY *Chrome Molybdenum*
QUALITY INDUSTRIAL TOOLING *Impact Sockets*

Manufactured from high quality chrome molybdenum steel. Black oxidised finish with permanent laser etched markings.



1/2" Drive Reducers & Adaptors

Male Drive x Female Drive	Weight each	Order Code KEN-583	Price/1 TB
1/2" x 3/8"	70g	-7410K	224.00
3/8" x 1/2"	70g	-7420K	231.00
3/4" x 1/2"	175g	-7430K	325.00
1/2" x 3/4"	335g	-7440K	642.00



Universal Ball Joint

Male Drive x Female Drive	Weight each	Order Code KEN-583	Price/1 TB
1/2" x 1/2"	140g	-7840K	462.00



1/2" Drive Metric, Deep Length, 6-Point
Conform to: **DIN 3129**.

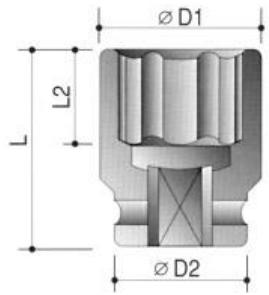

Socket (mm)	Style	Dimensions (mm)				Weight each	Order Code KEN-583	Price/1 TB
		D2	D1	L2	L			
10	A	25.0	17.5	14.0	78.0	170g	-2600K	277.00
11	A	25.0	18.7	14.0	78.0	170g	-2610K	277.00
12	A	25.0	20.0	14.0	78.0	175g	-2620K	277.00
13	A	25.0	21.0	14.0	78.0	180g	-2630K	308.00
14	A	25.0	22.5	17.0	78.0	210g	-2640K	286.00
15	A	30.0	23.7	17.0	78.0	200g	-2650K	305.00
16	A	30.0	25.0	17.0	78.0	200g	-2660K	305.00
17	A	30.0	26.0	17.0	78.0	260g	-2670K	338.00
18	A	30.0	27.5	17.0	78.0	270g	-2680K	338.00
19	A	30.0	28.7	19.0	78.0	260g	-2690K	316.00
21	B	30.0	30.0	24.0	78.0	260g	-2700K	327.00
22	C	30.0	32.0	24.0	78.0	290g	-2710K	341.00
23	C	30.0	32.0	24.0	78.0	290g	-2720K	368.00
24	C	30.0	35.0	24.0	78.0	290g	-2730K	398.00
27	C	30.0	38.7	54.0	78.0	330g	-2740K	423.00
28	C	30.0	40.0	54.0	78.0	350g	-2750K	458.00
30	C	30.0	42.0	54.0	78.0	450g	-2760K	501.00
32	C	30.0	44.0	54.0	78.0	370g	-2770K	518.00

1/2" Drive Extension Bars

Length (mm)	Weight each	Order Code KEN-583	Price/1 TB
125 (5")	230g	-7520K	365.00
150 (6")	270g	-7530K	409.00
250 (10")	445g	-7540K	716.00
300 (12")	620g	-7550K	916.00
380 (15")	740g	-7560K	1113.00



Hub Nut Impact Socket Set - 7 Piece

These extra deep sockets are six point single hexagon with a black oxidised finish and conform to **DIN 3129, Inch SAE and USA Federal Standard GGG-W-660A**.

Impact resistant storage case.

Socket sizes:
29, 30, 32, 34, 35, 36 and 38mm.



Number of Pieces	Weight each	Order Code KEN-583	Price/1 TB
7	5.3kg	-9888K	4720.00

1/2" Drive Inch Size, Deep Length, 6-Point

Conform to: **SAE, USA Federal Standard GGG-W-660A**.

Socket (inch)	Style	Dimensions (mm)				Weight each	Order Code KEN-583	Price/1 TB
		D2	D1	L2	L			
3/8"	A	22.0	16.0	14.0	78.0	140g	-2780K	227.00
7/16"	A	22.0	18.0	14.0	78.0	160g	-2790K	227.00
1/2"	A	22.0	20.0	14.0	78.0	200g	-2800K	227.00
9/16"	A	24.0	22.0	17.0	78.0	180g	-2810K	227.00
5/8"	B	24.0	24.0	17.0	78.0	210g	-2820K	227.00
11/16"	B	26.0	26.0	17.0	78.0	190g	-2830K	227.00
3/4"	B	28.0	28.0	19.0	78.0	235g	-2840K	227.00
13/16"	B	30.0	30.0	24.0	78.0	260g	-2850K	240.00
7/8"	B	32.0	32.0	24.0	78.0	290g	-2860K	240.00
15/16"	B	34.0	34.0	24.0	78.0	340g	-2870K	260.00
1"	B	36.0	36.0	24.0	78.0	340g	-2880K	312.00
1 1/16"	B	38.0	38.0	24.0	78.0	440g	-2890K	806.00
1 1/8"	C	38.0	40.0	24.0	78.0	410g	-2900K	806.00

1/2" Drive BSW Size, Deep Length, 6-Point

Conform to: **SAE, USA Federal Standard GGG-W-660A**.

Socket (BSW)	Style	Dimensions (mm)				Weight each	Order Code KEN-583	Price/1 TB
		D2	D1	L2	L			
5/16"	A	30.0	25.0	17.0	78	200g	-2910K	999.00
3/8"	A	30.0	27.5	17.0	78	250g	-2920K	999.00
7/16"	B	30.0	30.0	24.0	78	300g	-2930K	999.00
1/2"	C	30.0	35.0	24.0	78	360g	-2940K	999.00
9/16"	C	30.0	38.7	24.0	78	440g	-2950K	999.00
5/8"	C	30.0	40.0	24.0	78	480g	-2960K	999.00
11/16"	C	30.0	44.0	24.0	78	500g	-2970K	1558.00
3/4"	C	30.0	44.0	24.0	78	450g	-2980K	1459.00

7 Piece Set - Deep Metric

10, 13, 14, 17, 19, 24 and 30mm.



Number of Pieces	Weight each	Order Code KEN-583	Price/1 TB
7	2.20kg	-9880K	2429.00

PRODUCTS ARE ONLY AVAILABLE VIA YOUR DISTRIBUTOR

GROUP 583 IMPACT SOCKETS - 1/2" SQUARE DRIVE



Impact Wheel Nut Sockets

Socket sizes: 17, 19 and 21mm.
Colour coded for easy identification.
Can be used with retainer rings or pins.



Size (mm)	Overall Length	Weight each	Order Code KEN-583	Price/1 TB
17	85mm	225g	-3080K	540.00
19	85mm	225g	-3082K	540.00
21	85mm	255g	-3084K	540.00

3 Piece Set



Contains one of each size 17, 19 and 21mm.



3 PIECES

Number of Pieces	Weight each	Order Code KEN-583	Price/1 TB
3	895g	-9886K	1679.00

Impact Hexagon Bit Drivers

Hexagon sizes: 6, 7, 8, 10, 12, 14, 15, 17, 18 and 19mm.



Size (mm)	Overall Length	Weight each	Order Code KEN-583	Price/1 TB
6	75mm	95g	-3010K	296.00
7	75mm	95g	-3012K	296.00
8	75mm	105g	-3014K	296.00
10	75mm	120g	-3016K	296.00
12	75mm	130g	-3018K	296.00
14	75mm	150g	-3020K	296.00
15	75mm	155g	-3022K	296.00
17	75mm	175g	-3024K	352.00
18	75mm	195g	-3026K	352.00
19	75mm	200g	-3028K	352.00

10 Piece Set



Contains one of each size 6mm to 19mm as shown left.

10 PIECES



Number of Pieces	Weight each	Order Code KEN-583	Price/1 TB
10	1.76kg	-9882K	3338.00

Impact TX Bit Driver Sockets

TX drivers: T40, T45, T47, T50, T55, T60 and T70.



Size	Overall Length	Weight each	Order Code KEN-583	Price/1 TB
T40	55mm	80g	-3060K	490.00
T45	55mm	80g	-3062K	490.00
T47	55mm	85g	-3064K	490.00
T50	55mm	85g	-3066K	490.00
T55	55mm	90g	-3068K	490.00
T60	55mm	95g	-3070K	490.00
T70	55mm	105g	-3072K	490.00

16 Piece Set Contents:



TX drivers (length 55mm): T40, T45, T47, T50, T55, T60, T70.

16 PIECES

TX sockets: E10, E11, E12, E14, E16, E18, E20, E22, E24.
Conform to **DIN 3129**. Supplied in tough, impact-resistant plastic storage case.



Impact TX Sockets



Size	Overall Length	Weight each	Order Code KEN-583	Price/1 TB
E10	40mm	70g	-3040K	466.00
E11	40mm	70g	-3042K	466.00
E12	40mm	70g	-3044K	466.00
E14	45mm	75g	-3046K	466.00
E16	45mm	75g	-3048K	466.00
E18	45mm	75g	-3050K	466.00
E20	45mm	115g	-3052K	466.00
E22	45mm	140g	-3054K	490.00
E24	45mm	145g	-3056K	490.00

Number of Pieces	Weight each	Order Code KEN-583	Price/1 TB
16	1.91kg	-9884K	6180.00

HAND TOOLS



KENNEDY Chrome Molybdenum
QUALITY INDUSTRIAL TOOLING® **Impact Sockets**

Manufactured from high quality chrome molybdenum steel. Black oxidised finish with permanent laser etched markings.

3/4" Drive Metric, Standard Length, 6-Point
Conform to: **DIN 3129.**

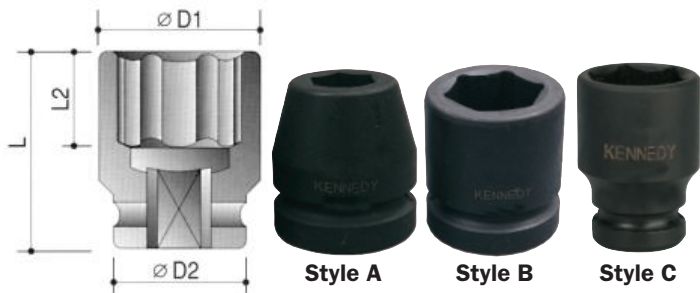

Socket (mm)	Style	Dimensions (mm)				Weight each	Order Code KEN-583	Price/1 TB
		D2	D1	L2	L			
16	A	44.0	27.0	11.0	50.0	367g	-3090K	597.00
17	A	44.0	31.0	12.0	50.0	400g	-3100K	597.00
18	A	44.0	32.0	13.0	50.0	433g	-3110K	597.00
19	A	44.0	33.0	13.0	50.0	433g	-3120K	603.00
20	A	44.0	34.0	14.0	50.0	433g	-3130K	607.00
21	A	44.0	35.0	15.0	50.0	400g	-3140K	615.00
22	A	44.0	37.0	15.0	50.0	400g	-3150K	615.00
23	A	44.0	38.0	16.0	50.0	400g	-3160K	626.00
24	A	44.0	39.0	16.0	50.0	433g	-3170K	615.00
25	A	44.0	40.0	16.0	50.0	433g	-3180K	615.00
26	A	44.0	41.0	16.0	50.0	433g	-3190K	615.00
27	A	44.0	43.0	19.0	54.0	433g	-3200K	615.00
28	B	44.0	44.0	19.0	54.0	433g	-3210K	615.00
29	C	44.0	45.0	21.0	54.0	450g	-3220K	643.00
30	C	44.0	47.0	21.0	54.0	500g	-3230K	615.00
32	C	44.0	49.0	22.0	56.0	500g	-3240K	625.00
33	C	44.0	51.0	22.0	56.0	500g	-3250K	710.00
34	C	44.0	52.0	22.0	56.0	550g	-3260K	710.00
35	C	44.0	53.0	22.0	56.0	550g	-3270K	710.00
36	C	44.0	54.0	25.0	56.0	600g	-3280K	710.00
38	C	44.0	57.0	25.0	58.0	600g	-3300K	678.00
41	C	44.0	60.0	27.0	58.0	700g	-3310K	805.00
42	C	44.0	62.0	27.0	58.0	700g	-3320K	860.00
46	C	44.0	67.0	30.0	63.0	800g	-3330K	1051.00
47	C	44.0	68.0	30.0	68.0	900g	-3340K	1077.00
50	C	54.0	71.0	32.0	72.0	1200g	-3350K	1356.00

3/4" Drive Inch Size, Standard Length, 6-Point
Conform to: **SAE, USA Federal Standard GGG-W-660A.**

Socket (inch)	Style	Dimensions (mm)				Weight each	Order Code KEN-583	Price/1 TB
		D2	D1	L2	L			
5/8"	A	38.0	27.5	11.0	50	267g	-3360K	419.00
11/16"	A	38.0	29.0	12.0	50	267g	-3370K	419.00
3/4"	A	38.0	30.0	13.0	50	267g	-3380K	419.00
13/16"	A	38.0	32.0	15.0	52	300g	-3390K	419.00
7/8"	A	38.0	34.0	15.0	52	300g	-3400K	419.00
15/16"	A	38.0	36.0	16.0	52	300g	-3410K	419.00
1"	C	38.0	40.0	16.0	52	333g	-3420K	419.00
1 1/16"	C	38.0	40.0	19.0	52	333g	-3430K	452.00
1 1/8"	B	42.0	42.0	21.0	52	333g	-3440K	452.00
1 3/16"	B	44.0	44.0	21.0	52	367g	-3450K	452.00
1 1/4"	B	44.0	44.0	22.0	52	367g	-3460K	452.00
1 5/16"	C	44.0	47.0	22.0	56	450g	-3470K	452.00
1 3/8"	C	44.0	50.0	22.0	56	450g	-3480K	452.00
1 7/16"	C	44.0	51.0	25.0	56	500g	-3490K	452.00
1 1/2"	C	44.0	53.0	25.0	56	500g	-3500K	805.00
1 5/8"	C	44.0	58.0	27.0	62	700g	-3520K	805.00
1 11/16"	C	44.0	63.5	27.0	62	800g	-3530K	805.00
1 3/4"	C	44.0	65.0	27.0	62	800g	-3540K	805.00
1 13/16"	C	44.0	67.0	30.0	68	900g	-3550K	805.00
1 7/8"	C	44.0	68.0	30.0	68	900g	-3560K	805.00

3/4" Drive BSW Size, Standard Length, 6-Point
Conform to: **SAE, USA Federal Standard GGG-W-660A.**

Socket (BSW)	Style	Dimensions (mm)				Weight each	Order Code KEN-583	Price/1 TB
		D2	D1	L2	L			
9/16"	A	44.0	41.0	16.0	50	433g	-3620K	1201.00
11/16"	C	44.0	48.0	21.0	56	450g	-3640K	1201.00
3/4"	C	44.0	51.0	22.0	56	500g	-3650K	1201.00
7/8"	C	44.0	57.0	25.0	58	600g	-3670K	2348.00
1"	C	44.0	63.0	27.0	63	800g	-3690K	2348.00
1 1/8"	C	44.0	68.0	30.0	68	900g	-3710K	2348.00
1 1/4"	C	44.0	74.0	32.0	72	1100g	-3720K	2348.00

3/4" Drive Metric, Deep Length, 6-Point
Conform to: **DIN 3129.**



Socket (mm)	Style	Dimensions (mm)				Weight each	Order Code KEN-583	Price/1 TB
		D2	D1	L2	L			
17	A	44.0	31.0	17.0	95.0	600g	-3810K	954.00
18	A	44.0	32.0	18.0	95.0	600g	-3820K	954.00
19	A	44.0	33.0	19.0	95.0	600g	-3830K	954.00
21	A	44.0	35.0	21.0	95.0	650g	-3850K	954.00
22	A	44.0	37.0	22.0	95.0	700g	-3860K	954.00
24	A	44.0	39.0	24.0	95.0	700g	-3880K	954.00
25	A	44.0	40.0	25.0	95.0	700g	-3890K	955.00
26	A	44.0	41.0	26.0	95.0	700g	-3900K	955.00
27	A	44.0	43.0	27.0	95.0	700g	-3910K	954.00
28	B	44.0	44.0	28.0	95.0	750g	-3920K	955.00
30	C	44.0	47.0	30.0	95.0	800g	-3940K	954.00
32	C	44.0	49.0	32.0	95.0	900g	-3960K	954.00
33	C	44.0	51.0	33.0	95.0	1000g	-3970K	1096.00
34	C	44.0	52.0	34.0	95.0	1000g	-3980K	955.00
36	C	44.0	54.0	36.0	95.0	1000g	-4000K	1043.00
38	C	44.0	57.0	38.0	95.0	1100g	-4020K	1223.00
41	C	44.0	60.0	38.0	95.0	900g	-4050K	1232.00
42	C	44.0	62.0	38.0	95.0	1100g	-4060K	2013.00
46	C	44.0	67.0	38.0	95.0	1300g	-4100K	1996.00
47	C	44.0	68.0	38.0	95.0	1300g	-4110K	2065.00

3/4" Drive Inch Size, Deep Length, 6-Point
Conform to: **SAE, USA Federal Standard GGG-W-660A.**

Socket (inch)	Style	Dimensions (mm)				Weight each	Order Code KEN-583	Price/1 TB
		D2	D1	L2	L			
3/4"	A	38.0	30.0	19.0	85.0	433g	-4160K	2065.00
7/8"	A	38.0	34.0	22.0	85.0	467g	-4180K	2065.00
15/16"	A	38.0	36.0	24.0	85.0	467g	-4190K	2065.00
1"	C	38.0	40.0	25.0	85.0	550g	-4200K	2065.00
1 1/16"	C	38.0	40.0	27.0	85.0	550g	-4210K	2065.00
1 1/8"	B	42.0	42.0	29.0	85.0	550g	-4220K	2272.00
1 3/16"	B	44.0	44.0	30.0	85.0	600g	-4230K	2065.00
1 1/4"	C	44.0	49.0	32.0	85.0	800g	-4240K	2065.00
1 5/16"	C	44.0	50.0	34.0	85.0	800g	-4250K	2272.00
1 7/16"	C	44.0	51.0	37.0	85.0	800g	-4270K	2065.00
1 1/2"	C	44.0	57.0	38.0	95.0	1100g	-4280K	2065.00
1 7/8"	C	44.0	68.0	38.0	95.0	1100g	-4340K	2065.00

3/4" Drive BSW Size, Deep Length, 6-Point
Conform to: **SAE, USA Federal Standard GGG-W-660A.**

Socket (BSW)	Style	Dimensions (mm)				Weight each	Order Code KEN-583	Price/1 TB
		D2	D1	L2	L			
3/4"	C	44.0	51.0	33.0	95	1000g	-4450K	2080.00
13/16"	C	44.0	53.0	35.0	95	1000g	-4460K	2282.00
7/8"	C	44.0	57.0	38.0	95	1100g	-4470K	2388.00

HAND TOOLS



Manufactured from high quality chrome molybdenum steel. Black oxidised finish with permanent laser etched markings.

3/4" Drive Reducers & Adaptors

Male Drive x Female Drive	Weight each	Order Code KEN-583	Price/1 TB
3/4" x 1/2"	175g	-7430K	325.00
1/2" x 3/4"	335g	-7440K	642.00
1" x 3/4"	175g	-7450K	704.00



Universal Ball Joint

Male Drive x Female Drive	Weight each	Order Code KEN-583	Price/1 TB
3/4" x 3/4"	640g	-7860K	1200.00



Retaining Rings
Supplied with pins



To Suit Outside Dia.	Square Drive	Weight each	Order Code KEN-583	Price/1 TB
38 - 44mm	3/4"	8g	-8200K	76.00
48 - 54mm	3/4"	16g	-8210K	103.00
46 - 58mm	1"	16g	-8300K	110.00
62mm	1"	18g	-8310K	152.00
78 - 86mm	1"	31g	-8320K	189.00

7 Piece Set - Metric

Standard length: 19, 24, 27, 30, 32, 36 and 46mm.



**7
PIECES**

Number of Pieces	Weight each	Order Code KEN-583	Price/1 TB
7	4.20kg	-9890K	4889.00

3/4" Drive Extension Bars



Length (mm)	Weight each	Order Code KEN-583	Price/1 TB
100 (4")	470g	-7570K	914.00
150 (6")	810g	-7580K	1073.00
230 (9")	900g	-7600K	1227.00
250 (10")	1350g	-7610K	1414.00
300 (12")	1500g	-7620K	1442.00
400 (15 3/4")	1900g	-7640K	1746.00

HAND TOOLS

1" Drive Metric, Standard Length, 6-Point
Conform to: DIN 3129.

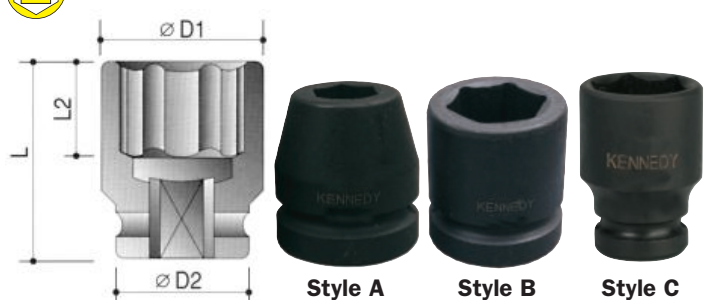

Socket (mm)	Style	Dimensions (mm)				Weight each	Order Code KEN-583	Price/1 TB
		D2	D1	L2	L			
21	A	54.0	38.0	15.0	60.0	700g	-5050K	906.00
22	A	54.0	40.0	15.0	60.0	700g	-5060K	906.00
24	A	54.0	42.0	18.0	60.0	800g	-5080K	906.00
25	A	54.0	43.0	18.0	60.0	800g	-5090K	906.00
26	A	54.0	44.5	18.0	60.0	800g	-5100K	906.00
27	A	54.0	46.0	19.0	60.0	800g	-5110K	906.00
28	A	54.0	47.0	19.0	62.0	800g	-5120K	906.00
29	A	54.0	48.0	19.0	62.0	800g	-5130K	906.00
30	A	54.0	50.0	21.0	62.0	700g	-5140K	906.00
32	A	54.0	52.0	22.0	62.0	800g	-5160K	906.00
33	A	54.0	53.0	22.0	62.0	800g	-5170K	906.00
34	B	54.0	55.0	22.0	62.0	800g	-5180K	906.00
35	B	54.0	55.0	22.0	62.0	800g	-5190K	906.00
36	B	54.0	57.0	25.0	67.0	900g	-5200K	906.00
37	B	54.0	59.0	25.0	67.0	900g	-5210K	1278.00
38	B	54.0	60.0	25.0	67.0	900g	-5220K	935.00
41	B	54.0	63.0	27.0	70.0	1000g	-5250K	993.00
42	B	54.0	65.0	27.0	74.0	1200g	-5260K	1278.00
46	B	54.0	70.0	30.0	76.0	1200g	-5290K	1278.00
47	B	54.0	71.5	32.0	76.0	1200g	-5300K	1278.00
48	B	54.0	72.5	32.0	76.0	1200g	-5310K	1278.00
50	B	54.0	75.0	35.0	80.0	1500g	-5330K	1278.00
52	B	54.0	77.0	35.0	84.0	1500g	-5350K	1278.00
55	B	54.0	81.0	35.0	84.0	1750g	-5380K	1871.00
56	B	54.0	82.0	40.0	84.0	1750g	-5390K	1405.00
60	B	54.0	87.0	42.0	87.0	1750g	-5430K	2308.00
65	B	54.0	93.0	42.0	90.0	2000g	-5460K	2774.00
70	B	54.0	100.0	42.0	96.0	3000g	-5480K	2873.00
75	B	86.0	106.0	45.0	98.0	4000g	-5500K	3879.00
80	B	86.0	112.0	48.0	100.0	4000g	-5520K	4096.00
85	B	86.0	118.0	52.0	105.0	5000g	-5530K	3064.00
90	B	86.0	125.0	52.0	105.0	5000g	-5550K	4276.00
95	B	86.0	131.0	52.0	115.0	6000g	-5570K	4459.00
100	B	95.0	137.0	58.0	115.0	7000g	-5580K	10052.00

1" Drive Inch Size, Standard Length, 6-Point
Conform to: SAE, USA Federal Standard GGG-W-660A.

Socket (inch)	Style	Dimensions (mm)				Weight each	Order Code KEN-583	Price/1 TB
		D2	D1	L2	L			
7/8"	A	51.0	39.0	15.0	58.0	550g	-5610K	1118.00
15/16"	A	51.0	40.0	18.0	58.0	550g	-5620K	1118.00
1"	A	51.0	42.0	18.0	58.0	550g	-5630K	1118.00
1 1/16"	A	51.0	44.0	19.0	58.0	600g	-5640K	1118.00
1 1/8"	A	51.0	46.0	19.0	58.0	600g	-5650K	1118.00
1 3/16"	A	51.0	48.0	21.0	60.0	650g	-5660K	1118.00
1 1/4"	B	51.0	51.0	22.0	60.0	650g	-5670K	1118.00
1 5/16"	C	52.0	53.0	22.0	62.0	733g	-5680K	1118.00
1 7/16"	C	52.0	56.0	25.0	62.0	700g	-5700K	1118.00
1 1/2"	C	52.0	58.0	25.0	62.0	800g	-5710K	1118.00
1 9/16"	C	52.0	60.0	25.0	62.0	800g	-5720K	1470.00
1 5/8"	C	52.0	61.5	27.0	62.0	800g	-5730K	1478.00
1 11/16"	C	52.0	65.0	27.0	64.0	900g	-5740K	1478.00
1 3/4"	C	58.0	66.0	27.0	64.0	1000g	-5750K	1478.00
1 13/16"	C	58.0	68.0	30.0	64.0	1100g	-5760K	1478.00
1 7/8"	C	58.0	70.0	32.0	66.0	1100g	-5770K	1478.00
2"	C	58.0	74.0	35.0	70.0	1250g	-5790K	1478.00
2 1/16"	C	58.0	75.0	35.0	70.0	1250g	-5800K	1627.00
2 1/8"	C	58.0	78.0	35.0	70.0	1250g	-5810K	1627.00
2 3/16"	C	62.0	80.0	35.0	72.0	1500g	-5820K	1480.00
2 1/4"	C	62.0	84.0	40.0	75.0	1500g	-5830K	1627.00
2 3/8"	C	62.0	87.0	42.0	78.0	1500g	-5850K	1627.00
2 1/2"	C	62.0	91.0	42.0	80.0	2500g	-5870K	1791.00
2 9/16"	C	62.0	93.0	42.0	80.0	2500g	-5880K	1791.00
2 5/8"	C	62.0	95.0	42.0	82.0	2500g	-5890K	1791.00
2 3/4"	C	62.0	100.0	42.0	96.0	3000g	-5910K	1791.00
2 13/16"	C	62.0	102.0	45.0	96.0	4000g	-5920K	1791.00
3"	C	86.0	107.0	48.0	100.0	4000g	-5950K	7658.00
3 1/8"	C	86.0	111.0	48.0	100.0	5000g	-5970K	7658.00
3 1/2"	C	86.0	124.0	52.0	105.0	5000g	-6000K	7658.00

1" Drive BSW Size, Standard Length, 6-Point
Conform to: SAE, USA Federal Standard GGG-W-660A.

Socket (BSW)	Style	Dimensions (mm)				Weight each	Order Code KEN-583	Price/1 TB
		D2	D1	L2	L			
1 1/16"	A	54.0	51.0	21.0	62	800g	-6080K	7658.00
3/4"	B	54.0	53.0	22.0	62	800g	-6090K	1061.00
13/16"	B	54.0	56.0	22.0	65	800g	-6100K	1167.00
1"	B	54.0	66.0	27.0	74	1200g	-6130K	1348.00
1 1/8"	B	56.0	70.0	32.0	66	1100g	-6140K	1470.00
1 1/4"	B	54.0	77.0	36.0	84	1500g	-6150K	1858.00
1 1/2"	B	62.0	89.0	42.0	78	1500g	-6170K	2255.00



IMPACT SOCKETS - 1" & 1 1/2" SQUARE DRIVE



Chrome Molybdenum Impact Sockets & Accessories

Manufactured from high quality chrome molybdenum steel. Black oxidised finish with permanent laser etched markings.

1" Drive Metric, Deep Length, 6-Point

Conform to: **DIN 3129.**

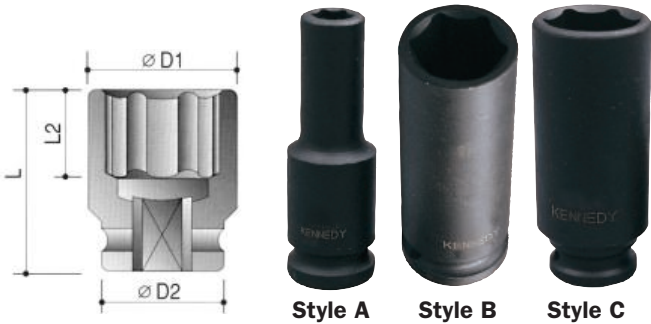

Socket (mm)	Style	Dimensions (mm)				Weight each	Order Code KEN-583	Price/1 TB
		D2	D1	L2	L			
23	A	54.0	41.0	23.0	100.0	1200g	-6250K	1289.00
24	A	54.0	42.0	24.0	100.0	1200g	-6260K	1289.00
27	A	54.0	46.0	27.0	100.0	1200g	-6290K	1289.00
28	A	54.0	47.0	28.0	100.0	1200g	-6300K	1289.00
30	A	54.0	50.0	30.0	100.0	1200g	-6320K	1289.00
32	A	54.0	52.0	32.0	100.0	1400g	-6340K	1289.00
33	A	54.0	53.0	33.0	100.0	1400g	-6350K	1289.00
34	B	54.0	55.0	34.0	100.0	1400g	-6360K	1290.00
36	B	54.0	57.0	35.0	100.0	1400g	-6380K	1289.00
37	B	54.0	59.0	37.0	100.0	1400g	-6390K	1430.00
38	B	54.0	60.0	38.0	100.0	1400g	-6400K	1430.00
41	B	54.0	63.0	38.0	100.0	1400g	-6430K	1430.00
42	B	54.0	65.0	38.0	100.0	1400g	-6440K	1430.00
46	B	54.0	70.0	38.0	100.0	1600g	-6480K	1622.00
50	B	54.0	75.0	38.0	100.0	2000g	-6520K	3190.00
52	B	54.0	77.0	40.0	100.0	1750g	-6540K	3190.00
55	B	54.0	81.0	40.0	100.0	2000g	-6570K	5681.00
56	B	54.0	82.0	40.0	105.0	2000g	-6580K	5681.00
60	B	54.0	87.0	42.0	120.0	2500g	-6630K	5681.00
65	B	54.0	93.0	42.0	125.0	3500g	-6660K	5681.00
70	B	54.0	100.0	42.0	125.0	5000g	-6680K	5681.00
75	B	86.0	106.0	45.0	135.0	6000g	-6700K	6838.00
80	B	86.0	112.0	48.0	135.0	6000g	-6720K	7448.00

Universal Ball Joint

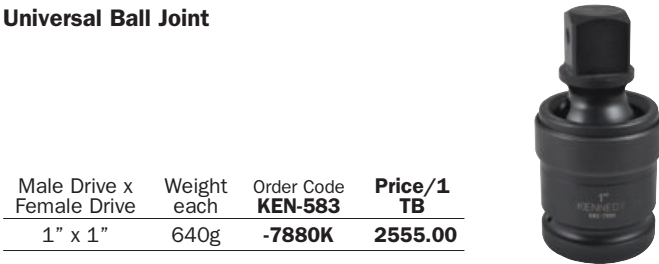

Male Drive x Female Drive	Weight each	Order Code KEN-583	Price/1 TB
1" x 1"	640g	-7880K	2555.00

1" Drive Reducers & Adaptors

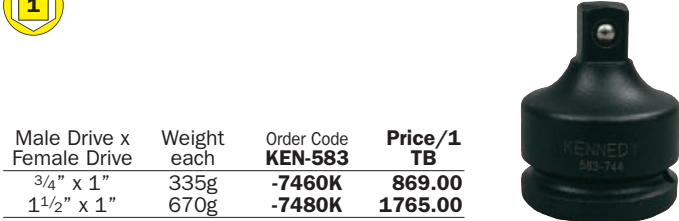

Male Drive x Female Drive	Weight each	Order Code KEN-583	Price/1 TB
3/4" x 1"	335g	-7460K	869.00
1 1/2" x 1"	670g	-7480K	1765.00

1" Drive Extension Bars

Length (mm)	Weight each	Order Code KEN-583	Price/1 TB
100 (4")	590g	-7650K	1280.00
150 (6")	610g	-7660K	1568.00
200 (8")	1000g	-7680K	2770.00
250 (10")	2100g	-7690K	1995.00
300 (12")	2500g	-7700K	1961.00
380 (15")	2600g	-7720K	2143.00

1" Drive Inch Size, Deep Length, 6-Point

Conform to: **SAE, USA Federal Standard GGG-W-660A.**

Socket (inch)	Style	Dimensions (mm)				Weight each	Order Code KEN-583	Price/1 TB
		D2	D1	L2	L			
1"	A	51.0	42.0	25.0	90.0	900g	-6760K	1592.00
1 1/16"	A	51.0	44.0	27.0	90.0	1000g	-6770K	1751.00
1 1/8"	A	51.0	46.0	29.0	90.0	1000g	-6780K	1825.00
1 3/16"	A	51.0	48.0	30.0	90.0	1000g	-6790K	1825.00
1 1/4"	B	51.0	51.0	32.0	90.0	1000g	-6800K	1825.00
1 5/16"	C	52.0	53.0	34.0	90.0	1200g	-6810K	1918.00
1 3/8"	C	52.0	54.0	35.0	90.0	1200g	-6820K	1918.00
1 1/2"	C	52.0	58.0	38.0	92.0	1200g	-6840K	1918.00
1 9/16"	C	52.0	60.0	38.0	92.0	1200g	-6850K	1964.00
1 5/8"	C	52.0	61.5	38.0	92.0	1200g	-6860K	1976.00
1 11/16"	C	52.0	65.0	38.0	92.0	1200g	-6870K	2153.00
1 3/4"	C	58.0	66.0	38.0	92.0	1400g	-6880K	2338.00
1 13/16"	C	58.0	68.0	38.0	92.0	1400g	-6890K	3055.00
1 7/8"	C	58.0	70.0	38.0	92.0	1600g	-6900K	2465.00
1 15/16"	B	58.0	72.0	38.0	100.0	1500g	-6910K	2918.00
2"	C	58.0	74.0	40.0	95.0	1750g	-6920K	3449.00
2 1/16"	C	58.0	75.0	40.0	95.0	1750g	-6930K	3533.00
2 1/8"	C	58.0	78.0	40.0	100.0	2000g	-6940K	3608.00
2 3/16"	C	62.0	80.0	40.0	100.0	2250g	-6950K	3714.00
2 1/4"	C	62.0	84.0	40.0	100.0	2500g	-6960K	3862.00
2 5/16"	C	62.0	86.0	40.0	105.0	2500g	-6970K	3979.00
2 3/8"	C	62.0	87.0	42.0	105.0	3000g	-6980K	4409.00
2 7/16"	C	62.0	89.0	42.0	110.0	3000g	-6990K	4510.00
2 1/2"	C	62.0	91.0	42.0	110.0	4000g	-7000K	4775.00
2 5/8"	C	62.0	95.0	42.0	125.0	4000g	-7020K	4934.00
2 3/4"	C	62.0	100.0	42.0	125.0	4000g	-7040K	5040.00
2 7/8"	C	86.0	104.0	42.0	125.0	5000g	-7060K	5252.00
2 15/16"	C	86.0	105.0	45.0	135.0	6000g	-7070K	5305.00
3"	C	86.0	107.0	48.0	135.0	6000g	-7080K	5571.00
3 1/8"	B	86.0	111.0	48.0	135.0	6000g	-7100K	5835.00

1" Drive BSW Size, Deep Length, 6-Point

Conform to: **SAE, USA Federal Standard GGG-W-660A.**

Socket (BSW)	Style	Dimensions (mm)				Weight each	Order Code KEN-583	Price/1 TB
		D2	D1	L2	L			
3/4"	A	54.0	53.0	33.0	100	1400g	-7150K	6101.00
1 3/8"	B	54.0	82.0	40.0	105	2000g	-7220K	9549.00
1 1/2"	B	62.0	89.0	42.0	110	3000g	-7230K	9814.00
1 3/4"	B	60.0	102.0	45.0	125	4000g	-7250K	10079.00

7 Piece Impact Socket Set

Socket sizes:
27, 30, 32, 33, 36, 41 and 46mm.

7 PIECES



Number of Pieces	Weight each	Order Code KEN-583	Price/1 TB
7	5.95kg	-9920K	10651.00

1 1/2" Drive Metric Size, Standard Length, 6-Point

Conform to: **SAE, USA Federal Standard GGG-W-660A.**

Socket (mm)	Style	Dimensions (mm)				Order Code KEN-583	Price/1 TB
		D2	D1	L2	L		
30		54.0	56.0	21.0	78.0	-8430K	3985.00
32		86.0	58.0	22.0	78.0	-8432K	3985.00
33		86.0	60.0	22.0	78.0	-8433K	3985.00
36		86.0	64.0	24.0	78.0	-8436K	3985.00
38		86.0	66.0	26.0	80.0	-8438K	3985.00
41		86.0	70.0	28.0	80.0	-8441K	3985.00
46		86.0	76.0	30.0	84.0	-8446K	3985.00
48		86.0	79.0	32.0	87.0	-8448K	3985.00
50		86.0	81.0	32.0	87.0	-8450K	3985.00
52		86.0	83.0	34.0	87.0	-8452K	3985.00
55		86.0	87.0	37.0	90.0	-8455K	3985.00
56		86.0	88.0	37.0	92.0	-8456K	3985.00
60		86.0	94.0	39.0	95.0	-8460K	5045.00
65		86.0	100.0	42.0	100.0	-8465K	5841.00
70		86.0	106.0	46.0	105.0	-8470K	6319.00
75		86.0	112.0	49.0	108.0	-8475K	7962.00
80		86.0	119.0	53.0	115.0	-8480K	9554.00
85		86.0	125.0	56.0	118.0	-8485K	10615.00
95		95.0	137.0	61.0	123.0	-8495K	13267.00

PRODUCTS ARE ONLY AVAILABLE VIA YOUR DISTRIBUTOR

GROUP 588 PIPE BENDERS/PIPE CUTTERS

KENNEDY Spring Loaded Pipe Cutter
QUALITY INDUSTRIAL TOOLING

Designed to cut copper, brass, aluminium, plastic and thin wall conduit, this pipe cutter has a 3-30mm capacity and spring loaded mechanism. It also features an internal pipe deburrer.



NEW



Capacity (mm)	Weight each	Order Code KEN-588	Price/1 TB
3 - 30		-4720K	1803.00

2-in-1 Automatic Ratcheting Pipe Cutter

Designed to cut copper, brass, aluminium, plastic and thin wall conduit, this pipe cutter has a 6 - 28mm capacity and spring loaded mechanism. It features a detachable ratchet handle for use in tight work areas and has a hanging hole for storage.



NEW



Capacity (mm)	Weight each	Order Code KEN-588	Price/1 TB
6 - 28		-4700K	1700.00
Spare Cutter	5g	-4690K	243.00

Midget Pipe Cutter

For use on copper, brass, aluminium and thin wall conduit. Supplied with spare blade. **Width:** 25mm. **Overall length:** 95mm.



Capacity (mm)	Weight each	Order Code KEN-588	Price/1 TB
3 - 28	270g	-5490K	615.00
Spare Cutter	5g	-5800K	114.00

Mini Pipe Cutter

Compact and robust construction ideal for use in confined spaces. Grooved rollers allow close-to-flare cuts. Large feed screw for accurate cutting of aluminium, brass, copper and steel tubing. **Length:** 66mm.



For Aluminium, Brass, Copper & Steel			
Capacity (mm)	Weight each	Order Code KEN-588	Price/1 TB
3 - 22	140g	-5450K	375.00
Spare Cutter	5g	-5800K	114.00

For Stainless Steel			
Capacity (mm)	Weight each	Order Code KEN-588	Price/1 TB
3 - 22	140g	-5700K	469.00
Spare Cutter	5g	-5790K	380.00

3-in-1 Bender

For bending 3, 4 and 6mm diameter copper and aluminium tubes up to 90°. With a graduated scale for partial bending. Ribbed die-cast aluminium construction for lightness and strength. **Length:** 140mm.



Capacity (mm)	Weight each	Order Code KEN-588	Price/1 TB
3, 4 & 6	150g	-6080K	1315.00

Multibender Pipe Bender

Precision bending up to 180°. Bends tube without distortion. Formers and guides will accept 12, 15 and 22mm O/D tube. For use in the plumbing, heating, refrigeration and air conditioning industries. Spare formers and guides also available (see table below).

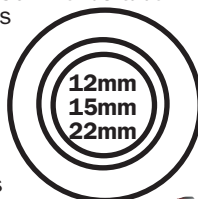

Tube Capacity	Weight each	Order Code KEN-588	Price/1 TB
12, 15 & 22mm	4.10kg	-6200K	3928.00

Accessories			
Tube Capacity	Weight each	Order Code KEN-588	Price/1 TB
12/15mm Former Only	172g	-6810K	586.00
12/22mm Former Only	321g	-6820K	1358.00
12mm Guide Only	123g	-6920K	186.00
15mm Guide Only	104g	-6940K	226.00
22mm Guide Only	287g	-6960K	277.00

3-in-1 Mini Bender

For bending 6, 8 and 10mm diameter copper and aluminium tubes up to 90°. Calibrated for left hand, right hand or offset ends in copper, brass, aluminium or steel. With a graduated scale for partial bending. Ribbed die-cast aluminium construction for lightness and strength.



Capacity (mm)	Angle Range	Weight each	Order Code KEN-588	Price/1 TB
6, 8 & 10	0 - 90°	430g	-6100K	1440.00

4-in-1 Micro Pipe Bender

High tensile steel with rivetted carbon steel. PVC grips. Carbon steel guides. Quick change aluminium formers. Bends copper and steel pipes. For pipe sizes 4.75, 6, 8 and 10mm.



Capacity	Weight each	Order Code KEN-588	Price/1 TB
4.75-10mm	565g	-6300K	1375.00

HAND TOOLS

Pipe Cutters

With high strength cast bodies and single cutting wheels with two rollers. Suitable for stainless steel, brass and copper tubes. All fitted with deburring blades.



-5500K



-5720K

For Aluminium, Brass, Copper & Steel			
Capacity (mm)	Weight each	Order Code KEN-588	Price/1 TB
3 - 30	195g	-5500K	478.00
Spare Cutter	5g	-5590K	234.00

For Stainless Steel			
Capacity (mm)	Weight each	Order Code KEN-588	Price/1 TB
3 - 32	310g	-5720K	821.00
Spare Cutter	5g	-5790K	380.00

Heavy Duty Pipe Cutters

With high strength cast bodies and single cutting wheels with four rollers for straighter cuts. Spring-loaded release mechanism allows quick diameter adjustment and release. Suitable for aluminium, brass and copper tubes. Fitted with deburring blades.



-5550K

-5690K

For Aluminium, Brass, Copper & Steel			
Capacity (mm)	Weight each	Order Code KEN-588	Price/1 TB
5 - 64	625g	-5550K	1660.00
Spare Cutter	5g	-5690K	274.00

KENNEDY Pipe **Deburrer**
QUALITY INDUSTRIAL TOOLING

For internal and external edges.



Capacity (mm)	Weight each	Order Code KEN-588	Price/1 TB
3-40 (1/8"-1 5/8")	250g	-5900K	460.00

Automatic Pipe Cutters

These robust pipe cutters will cut copper, brass, aluminium, PVC and thin-wall conduit. They automatically tighten and cut when turned around the pipe. The compact design makes them ideal for working in confined spaces.



Capacity	Weight each	Order Code KEN-588	Price/1 TB
15mm	186g	-4800K	572.00
22mm	192g	-4820K	603.00
Spare Cutter	5g	-4840K	109.00

Automotive Chain Pipe Cutter

Cuts thin wall pipe (stainless steel, copper, PVC etc.) up to 2.6mm thickness. The grip action eliminates hand gripping effort to ensure perfect tracking. Can be used for efficient cutting of exhaust pipes.



Capacity	Overall Length	Weight each	Order Code KEN-588	Price/1 TB
15 - 75mm	250mm	800g	-5100K	3861.00

Industrial Chain Pipe Cutter

Cuts wall pipe (welded and seamless) up to 6mm thick. The grip action eliminates hand gripping effort to ensure perfect tracking.



Capacity	Overall Length	Weight each	Order Code KEN-588	Price/1 TB
20 - 115mm	250mm	800g	-5120K	7758.00

Rubber Hose Cutter

6 - 37mm cutting capacity. Spring opening. Lightweight moulded polypropylene body. Stainless steel blade. Guillotine action ensures a clean cut every time. Handle retaining hook for compact storage and blade safety. Reversible blade. Not suitable for cutting metal.



Capacity (mm)	Weight each	Order Code KEN-588	Price/1 TB
6 - 37	270g	-5000K	520.00

Plastic Pipe Cutter - Mini Hose Type

Manufactured from tough hard wearing ABS plastic. Spring loaded with a heat-treated steel blade.



Capacity	Weight each	Order Code KEN-588	Price/1 TB
12.7mm	35g	-5400K	213.00

Plastic Pipe Cutters

Stainless steel blade. Diecast alloy body. Extra wide lower jaws for easy production of 90° cuts. Guillotine action ensures a clean cut every time. Handle retaining loop for compact storage and blade safety. Replaceable blade. Not suitable for cutting metal.



Capacity	Ratchet stages	Order Code KEN-588	Price/1 TB
6 - 36mm	4	-5840K	986.00
Spare blade - Stainless Steel		-5880K	482.00
12 - 42mm	7	-5842K	1313.00
Spare blade - Stainless Steel		-5882K	603.00
25 - 63mm	5	-5844K	3648.00
Spare blade - Carbon Steel		-5870K	1350.00
Spare blade - Stainless Steel		-5884K	1363.00

Capillary Tube Cutter

CTP1

These cutters are designed to cut annealed capillary tubing cleanly and easily without flattening or constricting the tubing.



Overall Length	Weight each	Order Code KEN-588	Price/1 TB
130mm (5")	65g	-4660K	617.00

HAND TOOLS



Double Flaring Tool & Pipe Cutting Set

Flaring tool for 3/16", 1/4", 5/16", 3/8", 7/16", 1/2" and 5/8" steel, aluminium and copper pipes. Cutter for 1/8" to 1 1/4" outside diameter pipe. Robust moulded case.

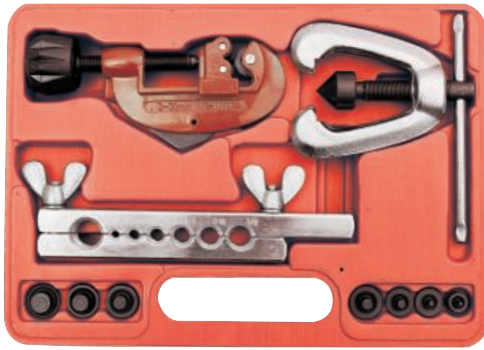

Capacity	Weight each	Order Code KEN-588	Price/1 TB
3/16" - 5/8"	1.5kg	-9570K	1633.00

Double Flaring Tool Set

Manufactured to double flare soft steel, aluminium and copper tubing up to .040" wall thickness producing SAE 45° flares. Heat treated alloy steel swivel is precision ground and chromed to reduce friction. Heat treated drop forged yoke. Each adaptor is clearly stamped with the size for easy identification. Bright lustre plate finish with contrasting black oxide. Will also produce a single flare.

Sizes: 3/16", 1/4", 5/16", 3/8", 7/16", 1/2", and 5/8".



Capacity	Weight each	Order Code KEN-588	Price/1 TB
3/16" - 5/8"	1.03kg	-9550K	1468.00

Pressure Testing Pump - 860psi

This robust piece of equipment has a 10ltr powder coated tank and comes with a 1.5m 1/2" reinforced hose and a pressure gauge graduated in Bar and PSI.

HEAVY DUTY
10 LTR

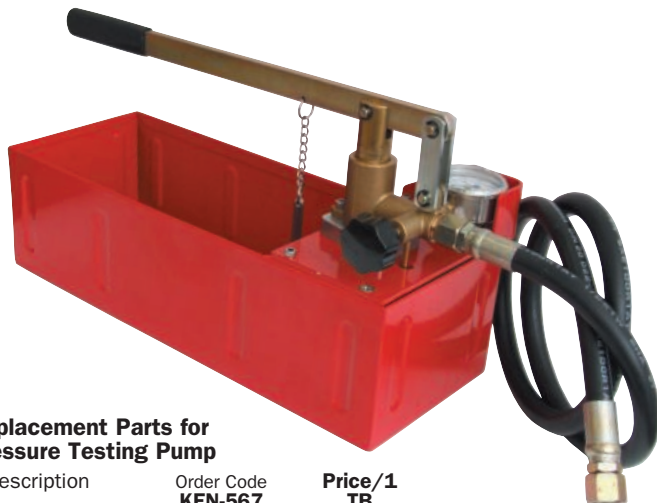

Replacement Parts for Pressure Testing Pump

Description	Order Code KEN-567	Price/1 TB
Gauge 60 Bar	-9000K	2833.00
Hose 60 Bar	-9020K	4192.00
Seal Kit 60 Bar	-9040K	372.00

Product Number	Tank Cap.	Test Bar	Capacity Psi	Hose Con	Weight each	Order Code KEN-588	Price/1 TB
zPTP060	10ltr	60	860	1/2 BSP	9kg	-8700K	22429.00

Tube Cutting & Bending Set

Contains flaring press, 45° spreader, 30mm capacity tube cutter, tube springs 14, 18, 16 and 20mm dia. Robust moulded case.

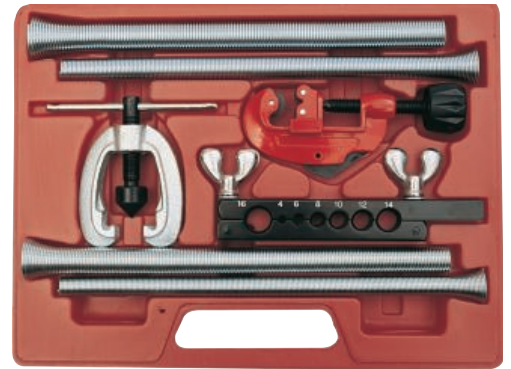

Capacity	Weight each	Order Code KEN-588	Price/1 TB
3/16" - 5/8"	2.3kg	-9600K	1545.00

Folding Double Flaring Tool Set

Suitable for use on copper pipe. Compact folding design. Robust moulded case. Single 45° flares: 3/16" to 5/8". Double flares: 3/16" to 1/2". Cutter: 1/8" to 1 1/4". Deburrer: 1/8" to 1 1/8" internal and external.

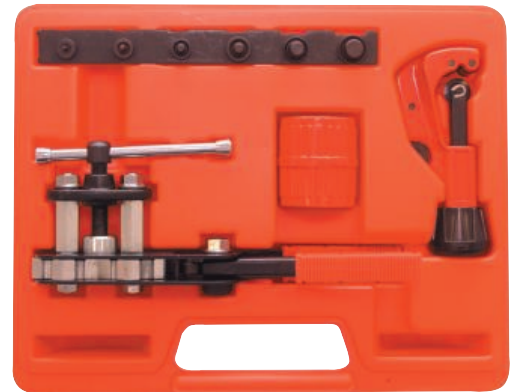

Capacity	Weight each	Order Code KEN-588	Price/1 TB
3/16" - 5/8"	2.5kg	-9620K	3206.00

5-Blade Pipe Crimper

With compound action and self-opening jaws, this 5-blade pipe crimper provides accurate indentations in round duct and stove pipe. It has soft grip handles for comfort and rust resistant blades.



Overall Length	Weight each	Order Code KEN-588	Price/1 TB
250mm	550g	-4680K	2059.00

All-in-1 Swaging Punch

Designed to make a tube connection without a fitting, this all-in-one swaging punch gives you one solder to join, reducing solder time by half. It has a nickel-chrome finish and is heat treated for durability.

Sizes: 1/4", 5/16", 3/8", 1/2", 5/8"



Sizes	Order Code KEN-588	Price/1 TB
As above	-9840K	464.00

NEW

HAND TOOLS



KENNEDY Drop Head Threader
QUALITY INDUSTRIAL TOOLING

Strong-arm ratchet threading set complete with 1/2", 3/4" and 1" quick change dies. Manufactured to the highest quality with comfortable 2-part handle to give greater leverage. Complete with tough moulded carry case.



Capacity	Weight each	Order Code	Price/1 TB
1/2" - 1"	4.5kg	KEN-588	
		-8800K	13849.00

Accessories

Description	Weight each	Order Code	Price/1 TB
Head 1/2" BSPT	660g	-8820K	2409.00
3/4" BSPT	584g	-8830K	2409.00
1" BSPT	839g	-8840K	2609.00
Die 1/2" BSPT	69g	-8920K	1381.00
3/4" BSPT	72g	-8930K	1381.00
1" BSPT	132g	-8940K	1381.00
Ratchet	1.5kg	-8980K	4423.00

Pipe Vices

Used for repetitive tasks on pipework. The frame of the pipe vice is made from cast iron with jaws made from hardened tool grade alloy steel with a corrosion resistant coating. The top jaw of the pipe vice is held in position with a hook which automatically engages when the vice is closed. The stand is fitted with an integral tool tray, wide angled legs give greater stability and the folding design provides easy storage and transportation.



Group 445

Pipe Vice Only

Product Number	Capacity (mm)	Weight each	Order Code	Price/1 TB
VPO55	8-55	4.50kg	-8020K	6695.00
VP085	10-85	6.70kg	-8040K	7725.00
VP100	15-100	10.3kg	-8060K	8652.00

Pipe Vice & Stand

Product Number	Capacity (mm)	Weight each	Order Code	Price/1 TB
VPS055	8-55	24.6kg	-8220K	13905.00
VPS085	10-85	31.6kg	-8240K	15090.00

PRODUCTS ARE ONLY AVAILABLE VIA YOUR DISTRIBUTOR

GROUP 588 PIPE WRENCHES

KENNEDY Pipe Wrenches
QUALITY INDUSTRIAL TOOLING

Jaws are serrated in the opposite direction to ensure a secure grip. Used mainly in the plumbing industry for gripping pipes and nuts. Cast iron frame, drop forged handles and jaws. All moving parts are heat treated. Used mainly in the plumbing industry for gripping pipes and nuts. Conform with **BS 3594 : Part 1**.

Standard Duty - For most general purpose applications.



Length (mm)	Capacity (mm)	Weight per 6	Order Code KEN-588	Price/1 TB
205 (8")	27	1.70kg	-2080K	1040.00
255 (10")	35	3.30kg	-2100K	1258.00
305 (12")	43	4.40kg	-2120K	1476.00
355 (14")	50	6.50kg	-2140K	1722.00
455 (18")	60	10.10kg	-2180K	2295.00
600 (24")	76	24.00kg	-2240K	3607.00
900 (36")	102	29.20kg	-2360K	8852.00

Heavy Duty - For more industrial applications.



Length (mm)	Capacity (mm)	Weight per 6	Order Code KEN-588	Price/1 TB
205 (8")	27	2.60kg	-3080K	1258.00
255 (10")	35	5.00kg	-3100K	1313.00
305 (12")	43	7.50kg	-3120K	1722.00
355 (14")	50	10.00kg	-3140K	1831.00
455 (18")	60	16.10kg	-3180K	2515.00
600 (24")	76	25.70kg	-3240K	3826.00
900 (36")	102	30.70kg	-3360K	9235.00
1200 (48")	140	94.80kg	-3480K	17594.00

Aluminium Pipe Wrenches

Lightweight aluminium alloy handles. As robust as heavy duty cast iron wrenches.



Length (mm)	Capacity (mm)	Weight per 6	Order Code KEN-588	Price/1 TB
200 (8")	27	1.65kg	-3680K	1476.00
255 (10")	35	3.20kg	-3700K	1804.00
305 (12")	43	4.70kg	-3720K	1859.00
355 (14")	50	6.25kg	-3740K	2378.00
455 (18")	60	9.90kg	-3780K	2951.00
600 (24")	80	11.20kg	-3840K	3388.00
900 (36")	102	14.00kg	-3860K	4919.00
1200 (48")	140	35.00kg	-3880K	6175.00

SENATOR Heavy Duty Wrenches
QUALITY TOOLING

Heavy duty pattern. Drop forged, single piece body.



Length (mm)	Weight each	Order Code SEN-588	Price/1 TB
200 (8")	0.40kg	-5080K	212.00
250 (10")	0.67kg	-5100K	318.00
300 (12")	1.00kg	-5120K	346.00
350 (14")	1.30kg	-5140K	424.00
450 (18")	2.00kg	-5180K	617.00
600 (24")	3.50kg	-5240K	953.00
900 (36")	5.90kg	-5360K	1592.00
1200 (48")	16.00kg	-5480K	2653.00

Swedish Pattern Pipe Wrenches

Narrow design for confined areas, used for gripping pipe and nuts. Forged chrome vanadium heat treated steel. Knurled adjusting nut with guiding reinforcement on handle. Conform to **DIN 5234**.

90° Type

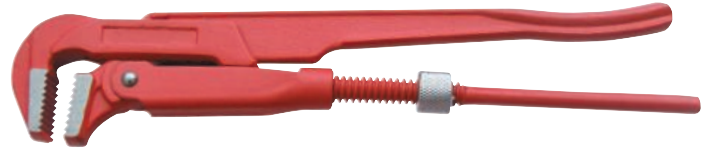

Length (mm)	Max. Jaw Opening	Weight each	Order Code KEN-588	Price/1 TB
300 (12")	38mm	0.76kg	-4120K	1722.00
400 (16")	46mm	1.40kg	-4160K	2421.00
560 (22")	65mm	2.50kg	-4220K	3919.00

'S' Type

'S' shaped jaws grip at three points to ensure a maximum grip.



Length (mm)	Max. Jaw Opening	Weight each	Order Code KEN-588	Price/1 TB
225 (9")	22mm	0.40kg	-4290K	1394.00
300 (12")	38mm	0.85kg	-4320K	1722.00
405 (16")	46mm	1.45kg	-4360K	2432.00
530 (21")	65mm	2.45kg	-4410K	3841.00

Adjustable Pipe Wrenches

All-purpose wrenches with precision milled and hardened teeth which grips the workpiece tighter the more pressure is applied. Pressed steel handles with high carbon steel profiled jaws.

Jaw Adjustment:

(7") 175mm:

1.5 - 38mm
(1/16" - 1 1/2").

(9") 225mm:

3.0 - 64mm
(1/8" - 2 1/2").

(12") 300mm:

6.0 - 75mm
(1/4" - 3").



Thumb Adjustment	Length (mm)	Weight each	Order Code KEN-588	Price/1 TB
No	175 (7")	300g	-2710K	603.00
	225 (9")	600g	-2720K	617.00
	300 (12")	1000g	-2730K	720.00
Yes	175 (7")	300g	-2760K	567.00
	225 (9")	600g	-2770K	670.00
	300 (12")	1000g	-2780K	1167.00

SENATOR Speed Wrench Set
QUALITY TOOLING

Contains two multi-purpose self-adjusting wrenches 200mm (8"), maximum capacity 25mm and 300mm (12"), maximum capacity 35mm. Can be used on pipes, nuts and bolts and will also grip rounded nuts. Manufactured from fully chrome-plated drop forged steel.

2 PIECES



Capacity	Weight each	Order Code SEN-588	Price/1 TB
25mm & 35mm	925g	-9010K	1347.00

HAND TOOLS



KENNEDY *Self Adjusting Basin Wrenches*
QUALITY INDUSTRIAL TOOLING

Heavy Duty

With spring loaded jaws of hardened forged and milled steel. Jaw swivels 180° allowing easy tightening and loosening of basin nuts on both 15mm and 22mm pipes.

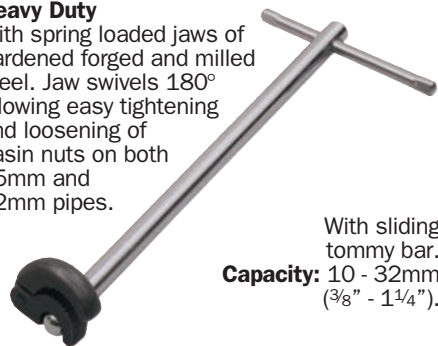

With sliding tommy bar.
Capacity: 10 - 32mm (3/8" - 1 1/4").

Overall Length	Weight each	Order Code KEN-588	Price/1 TB
265mm	520g	-6020K	346.00

Telescopic Type Basin Wrench

Box section extending shank with spring loaded retainer. Spring loaded jaws of hardened forged and milled steel.

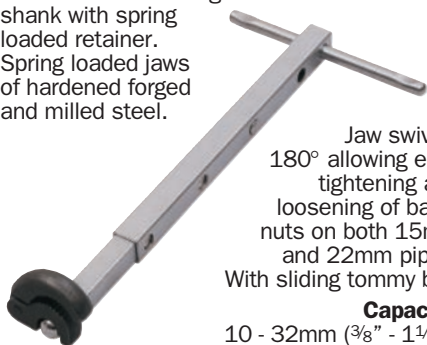

Jaw swivels 180° allowing easy tightening and loosening of basin nuts on both 15mm and 22mm pipes. With sliding tommy bar.
Capacity: 10 - 32mm (3/8" - 1 1/4").

Overall Length	Weight each	Order Code KEN-588	Price/1 TB
245mm	840g	-6030K	503.00

Back Spanner Basin Wrenches

For use in vertical or horizontal confined spaces. Grips on smooth and oily surfaces. Double ended wrench for 13mm (1/2") and 32mm (1 1/4") lavatory and basin nuts. Made from cast iron.



Overall Length	Weight each	Order Code KEN-588	Price/1 TB
350mm	590g	-6000K	446.00

Radiator Key

Square opening brass key for use on domestic radiator bleed screws with easy to turn clock key type handle for releasing air from water filled radiators.



Type	Weight each	Order Code KEN-588	Price/1 TB
Radiator Key	10g	-6070K	97.00

Multi Key - 4-Way

For gas, water and electric meter boxes, air conditioning units, stop valves, mains consoles etc., central heating pump cocks, some radiator valves and drain off valves.

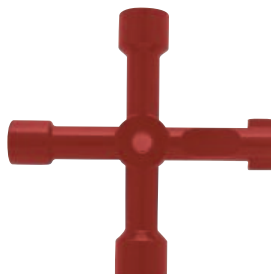

Type	Weight each	Order Code KEN-588	Price/1 TB
4-Way Key	75g	-6060K	215.00

9-in-1 Universal Key Wrench

Can be used on most technical locking systems in electrical engineering, supply of gas, water, air conditioning and ventilation systems.

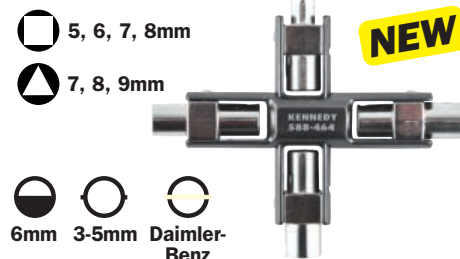

Description	Order Code KEN-588	Price/1 TB
9-in-1 Key Wrench	-4640K	3089.00

Immersion Heater Box Spanner

This heavy duty box spanner complete with tommy bar will reach recessed elements on most hot water tanks.



Capacity	Weight each	Order Code KEN-588	Price/1 TB
86mm	520g	-6050K	720.00

Adjustable Strap

Industrial strength rubber strap. Strap can be easily adjusted and used on irregular shapes.



Capacity (mm)	Weight each	Order Code KEN-588	Price/1 TB
15 to 150	600g	-1500K	738.00

Chain Pipe Wrenches

For gripping tubes, piping and irregular shaped objects. The chain is looped around the object and locked on the head. The head will automatically grip in the direction of the turn and the object can be rotated. The head is double ended and fully reversible for longer tool life. Manufactured from hardened and tempered carbon steel to US specification GG-W-651.



Diameter (mm)	Length (mm)	Order Code KEN-588	Price/1 TB
63 (2 1/2")	525 (21")	-4500K	3580.00
100 (4")	900 (36")	-4560K	5149.00

Chain Separators

All steel construction, industry quality roller and bush chain separator. Designed for separating roller and bush chains that have end softened pins, to remove hardened pins the ends must first be removed by grinding. Simple to operate grip the chain in the self-closing jaws that also supports the chain to prevent twisting as the link pins are driven out. Then turn the T-handle to drive the pins out. Always ensure that the machine is switched off before disconnecting or connecting a chain.

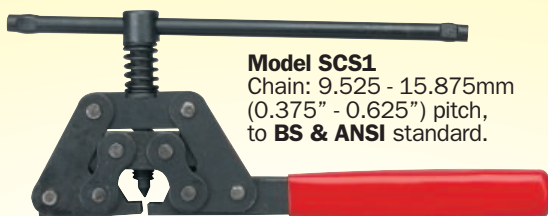

Model SCS1
Chain: 9.525 - 15.875mm (0.375" - 0.625") pitch, to BS & ANSI standard.

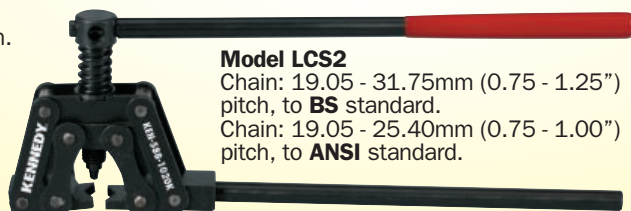

Model LCS2
Chain: 19.05 - 31.75mm (0.75 - 1.25") pitch, to BS standard.
Chain: 19.05 - 25.40mm (0.75 - 1.00") pitch, to ANSI standard.

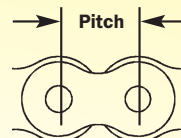

Roller Chain
Pin, roller and bush assembly.

Bush Chain
Identical to roller chain, but with the omission of the roller.

Product Number	Weight each	Order Code KEN-588	Price/1 TB
SCS1	445g	-1010K	1789.00
LCS2	765g	-1020K	2023.00

GROUP 588 DRAINAGE EQUIPMENT

KENNEDY Drain Rods
QUALITY INDUSTRIAL TOOLING

Use for cleaning and unblocking drains, pipes and sewers. A range of accessories are also available including drop scrapers, double worm screws and plungers. Manufactured from polypropylene fitted with solid brass joints securely fitted with brass rivets. Rods are strong, durable and rigid with the right amount of drain rod flexibility.

Available with two different types of joint:

Universal: rods fitted with this type of joint should only be rotated in a clockwise direction.

Lockfast: rods fitted with this type of joint can be rotated in either direction and will remain secure in the most demanding conditions.

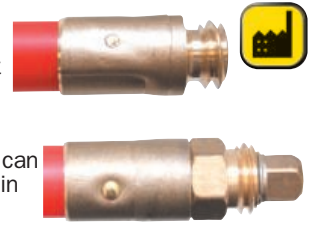

Type	Weight each	Order Code KEN-588	Price/1 TB
Universal	190g	-7240K	252.00

Type	Weight each	Order Code KEN-588	Price/1 TB
Lockfast	245g	-7250K	556.00

Drain Rod Sets

Use for cleaning and unblocking drains, pipes and sewers. Manufactured from polypropylene fitted with solid brass joints securely fitted with brass rivets. Rods are strong, durable and rigid with the right amount of drain rod flexibility.

Contents:

- 10x 20 x 900mm rods,
 - 1x 100mm double worm screw,
 - 1x 100mm plunger,
 - 1x 100mm drop scraper,
- Also supplied with two rod ties.



13 PIECES

Type	Weight each	Order Code KEN-588	Price/1 TB
Universal	2.37kg	-7200K	3147.00

Type	Weight each	Order Code KEN-588	Price/1 TB
Lockfast	2.60kg	-7210K	10134.00

Drain Rod Bag

Used for carrying up to 10x 36" rods.



Capacity	Weight each	Order Code KEN-588	Price/1 TB
10 Rods	160g	-7280K	800.00

Drain Testing Dye

Used to locate the direction of water flow in pipes, drains etc. soluble in water. 200g jars.



Colour	Weight each	Order Code KEN-588	Price/1 TB
Green	200g	-7700K	1776.00
Red	200g	-7710K	1776.00
Blue	200g	-7720K	1776.00

Accessories

Available with two different type of joints:

Universal: rods fitted with this type of joint should only be rotated in a clockwise direction.

Lockfast: rods fitted with this type of joint can be rotated in either direction and will remain secure in the most demanding conditions.

Double Worm Screw

Pierces blockages such as paper or rags and the obstruction is drawn back to clear the pipe.

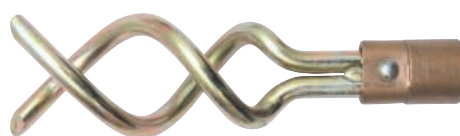

Size	Type	Order Code KEN-588	Price/1 TB
100mm (4")	Universal	-7340K	308.00
100mm (4")	Lockfast	-7350K	335.00

Accessories Continued

Rubber Plunger

Builds up pressure of water to force obstruction clear. One piece rubber.



Size	Type	Order Code KEN-588	Price/1 TB
100mm (4")	Universal	-7300K	158.00
100mm (4")	Lockfast	-7310K	258.00
150mm (6")	Universal	-7420K	308.00
150mm (6")	Lockfast	-7430K	335.00

Drop Scraper

Glides over small obstructions and drops into a vertical position to allow material to be dragged back.



Size	Type	Order Code KEN-588	Price/1 TB
100mm (4")	Universal	-7380K	258.00
100mm (4")	Lockfast	-7390K	284.00
150mm (6")	Universal	-7460K	361.00
150mm (6")	Lockfast	-7470K	365.00

Pipe Unblocker

This pipe unblocker is easy to use and comes with a corrosion-resistant body. Its 4.6m coil length makes it ideal for unblocking domestic waste/drain pipes.



Description	Order Code KEN-588	Price/1 TB
Pipe Cleaner 4.6m	-6700K	1200.00

Drain Test Bungs

Used to pressure test or temporarily seal the end of an open pipe which is newly laid or decommissioned, preventing the ingress of water, gases, rodents.



Pipe Size Metric	Capacity Inch	Min/Max Operating Range	BSP Outlet	Order Code KEN-588	Price/1 TB
100	4"	94-110mm	1/2"	-7500K	751.00
150	6"	146-163mm	1/2"	-7510K	1077.00
200	8"	191-211mm	1"	-7520K	3539.00
225	9"	216-235mm	1"	-7530K	4152.00
300	12"	296-314mm	1"	-7540K	5644.00

HAND TOOLS

KENNEDY *Heavy Duty Adjustable Twin Roller Stand*
QUALITY INDUSTRIAL TOOLING

Ideal for supporting long and heavy duty pipe and timber. Adjustable feet. Lock-knob to securely lock-in height settings. Cast iron base with levelling pads for stability. Adjustable height 29" (736mm) to 43" (1092mm), 1 3/8" (35mm) diameter x 6" (150mm) width with spring-loaded axle. Adjustable roller stands with double rollers forming vee groove for added stability allowing easy rotation and feed of up to 7" (180mm) diameter pipe or timber.



Type	Weight each	Order Code KEN-588	Price/1 TB
Adjustable Twin	6.20kg	-9030K	4722.00

Heavy Duty Self-Levelling Single Roller Stand

HRS020
 Heavy duty all-steel welded construction. Unique levelling pads for uneven floors. Adequately supports up to 100kg. Legs fold flat for easy storage and transportation. Pre-assembled and ready to use. Height adjustment from 758 to 1197mm. **Bearing roller: 51mm x 284mm.**



Type	Weight each	Order Code KEN-588	Price/1 TB
Self-Levelling	8.00kg	-9020K	5192.00

Fibre Grips

Fibre-faced aluminium vice jaws for use with copper, aluminium, brass and wooden workpieces to prevent marking of work surface. Supplied in pairs.

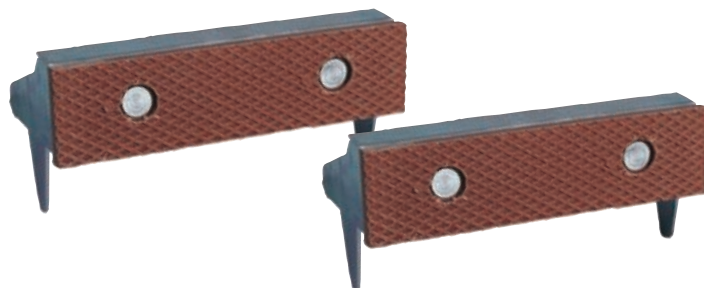

Width (mm)	Weight each	Order Code KEN-589	Price/Pr TB
76 (3")	165g	-0300K	324.00
90 (3 1/2")	180g	-0350K	567.00
100 (4")	180g	-0400K	567.00
110 (4 1/2")	230g	-0420K	567.00
115 (4 1/2")	245g	-0450K	582.00
127 (5")	245g	-0500K	593.00
133 (5 1/4")	260g	-0520K	603.00
150 (6")	280g	-0600K	823.00

Magnetic Vice Jaws

Suitable for all steel and iron vices - engineers, fitters, machine. Quick and easy to fit and remove.

Profiled Aluminium

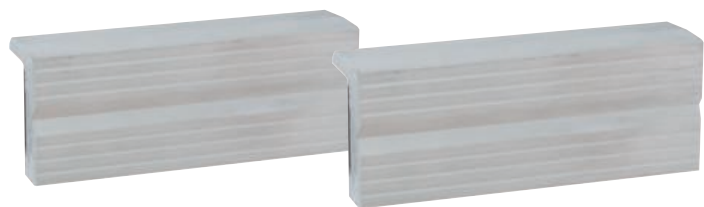

Width (mm)	Weight each	Order Code KEN-589	Price/Pr TB
75 (3")	125g	-1300K	677.00
100 (4")	165g	-1400K	890.00
125 (5")	210g	-1500K	890.00
150 (6")	250g	-1600K	934.00

Aluminium Jaw with a Fibre Face

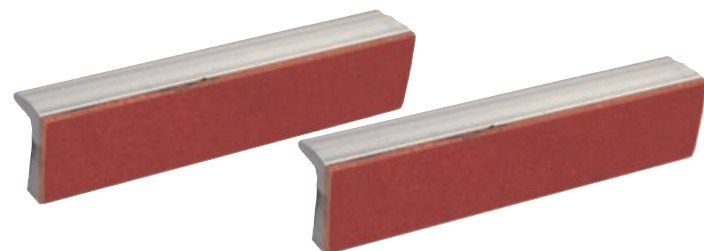

Width (mm)	Weight each	Order Code KEN-589	Price/Pr TB
75 (3")	115g	-2300K	912.00
100 (4")	160g	-2400K	1066.00
125 (5")	195g	-2500K	1135.00
150 (6")	235g	-2600K	1147.00

Aluminium Jaw with a Rubber Face



Width (mm)	Weight each	Order Code KEN-589	Price/Pr TB
75 (3")	120g	-3300K	890.00
100 (4")	160g	-3400K	1066.00
125 (5")	210g	-3500K	1140.00
150 (6")	250g	-3600K	1200.00

HAND TOOLS



General-Purpose Tinsnips



Manufactured from drop forged carbon steel with hardened and precision ground blades which can be re-sharpened.

Standard Type

A traditional design, suitable for the general-purpose cutting of sheet metal in a wide range of materials such as copper, aluminium and mild steel.



Length (mm)	Weight per 6	Order Code KEN-591	Price/1 TB
200 (8")	1.90kg	-1080K	604.00
250 (10")	2.90kg	-1100K	741.00
300 (12")	4.00kg	-1120K	1056.00
360 (14")	5.10kg	-1140K	1220.00

Heavy Duty Right Hand Universal Snips

The cranked design allows for extra leverage to be safely applied. Ideal for the more demanding cutting application. PVC dipped handle.

Straight Blade

Universal cutting.

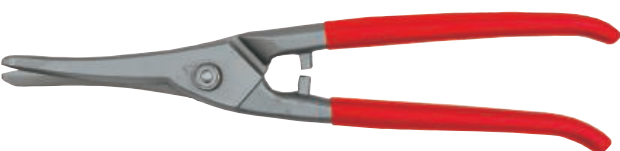

Length (mm)	Weight per 6	Order Code KEN-591	Price/1 TB
250 (10")	3.95kg	-1950K	1919.00

Cranked Blade Heavy-Duty Snips

The cranked design allows for extra leverage to be safely applied. Ideal for the more demanding cutting application. PVC dipped handle.

Right Hand

Designed to cut straight or to the right, leaving waste material to the left of the blade.

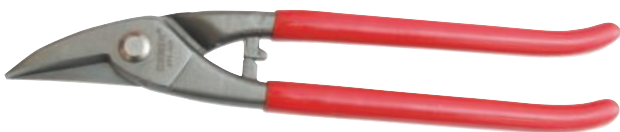

Length (mm)	Weight per 6	Order Code KEN-591	Price/1 TB
280 (11")	3.40kg	-1690K	1208.00
360 (14")	5.60kg	-1700K	1648.00

Left Hand

Designed to cut straight or to the left leaving waste material to the right of the blade.

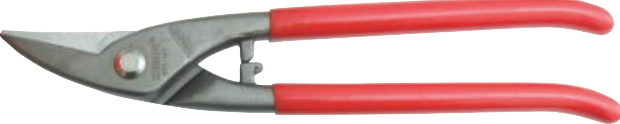

Length (mm)	Weight per 6	Order Code KEN-591	Price/1 TB
280 (11")	3.40kg	-1670K	1208.00



General Purpose Straight Blade Tinsnips



A traditional drop forged carbon steel design with induction hardened and ground blades. Suitable for the general purpose cutting of sheet metal in a wide range of materials such as copper, aluminum and mild steel.



Length (mm)	Weight each	Order Code SEN-591	Price/1 TB
250 (10")	330g	-1100K	361.00

Jeweller's Snips

Short bladed tinsnip giving precise control on intricate workpieces, ideal for jewellers, silversmiths and model makers.

Straight Cutting



Curved Cutting



Type	Length (mm)	Weight per 6	Order Code KEN-591	Price/1 TB
Straight	180 (7")	1.30kg	-1550K	559.00
Curved	180 (7")	1.30kg	-1560K	628.00

Multi-Purpose Cutters

For cutting cardboard, leather, rope, cord, wire, paper and many other materials. Precision ground and hardened stainless steel blades HRC 50~54 with one serrated cutting edge to reduce slipping. Lightweight polypropylene handles with spring-loaded action with an easy reach thumb catch convenient for right and left hand users.

Cutting length: 42mm (1 5/8").

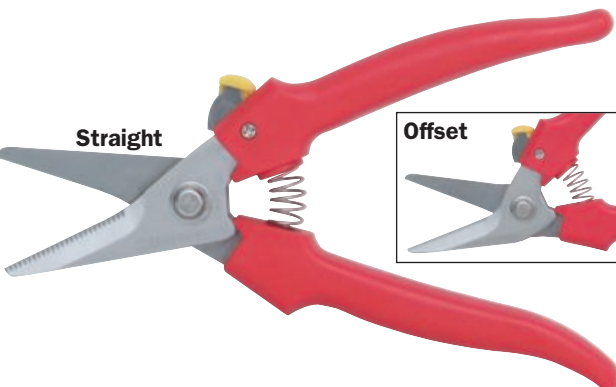

Type	Length (mm)	Weight each	Order Code KEN-591	Price/1 TB
Straight	190 (7 1/2")	180g	-2340K	778.00
Offset	185 (7 3/4")	150g	-3100K	670.00



KENNEDY *Compound Action Aviation Snips*
QUALITY INDUSTRIAL TOOLING

Drop forged chrome vanadium ground blades (54 - 58HRC). The double fulcrum compound action amplifies the pressure applied for easier cutting of up to 1.2mm cold rolled steel sheet. Spring loaded, self-opening action for fast, effortless feed and single-handed operation. Anti-slip guards for extra safety. Thumb lock ensures the jaws stay closed when not in use. For use on mild steel and other non-ferrous materials.

Left Hand or Right Hand Cut
Cut from tight curve to straight.



Type	Length (mm)	Weight per 6	Order Code KEN-591	Price/1 TB
Right Hand	270 (10½")	2.40kg	-2170K	558.00
Left Hand	270 (10½")	2.40kg	-2160K	1075.00

Straight Cut

Cuts straight, left or right. Self-opening action for fast, effortless feed, with a built-in convenient, protective safety latch.



Length (mm)	Weight per 6	Order Code KEN-591	Price/1 TB
270 (10½")	2.50kg	-2180K	604.00

3 Piece Set Contents:

1x pair 250mm (10") right hand aviation snips 591-217,
1x pair 250mm (10") left hand aviation snips 591-216,
1x pair 250mm (10") straight aviation snips 591-218.



Number of Pieces	Weight each	Order Code KEN-591	Price/1 TB
3	1.22kg	-2240K	2080.00

Offset Cut (Heavy Duty)

The offset blades keep hands clear of metal. Spring-action for fast, effortless feed. Non-slip, textured grips and safety latch for superior control and a handy hang-up hole.



Type	Length (mm)	Weight per 6	Order Code KEN-591	Price/1 TB
Right Hand	250 (9¾")	2.40kg	-2150K	754.00
Left Hand	250 (9¾")	2.40kg	-2140K	1200.00

SENATOR *Sheet Metal Nibbler*
QUALITY TOOLING

For cutting sheet materials without bending or distorting, metal up to 1.2mm (18 gauge) and plastic up to 2mm (14 gauge). Positive spring loaded action enables the cutter to be used single-handed. Replaceable molybdenum front blade. Side jaws for wire cutting. Safety jaw lock.

Overall length: 250mm.



Length (mm)	Weight each	Order Code SEN-591	Price/1 TB
250 (10")	505g	-8090K	677.00
Replacement Blade	25g	-8095K	183.00



GROUP 592 BOLT & CABLE CUTTERS

KENNEDY *Low Tensile Bolt Cutters - Centre Cut*
QUALITY INDUSTRIAL TOOLING

Drop forged hardened carbon steel suitable for round and flat sections. With adjustable arms. With cushion grips. 300mm model has cast handles - all other sizes have tubular handles for maximum strength combined with low weight. Conform to **JIS B4643**.



Cut Type	Overall Length (mm)	Cutting Capacity		Weight each	Order Code KEN-592	Price/1 TB
		15°HRC	40°HRC			
Centre	300 (12")	5mm	4mm	0.80kg	-3520K	1350.00
	350 (14")	7mm	5mm	1.00kg	-3540K	1545.00
	460 (18")	8mm	6mm	1.60kg	-3560K	1803.00
	600 (24")	10mm	8mm	2.60kg	-3580K	2550.00
	760 (30")	13mm	10mm	3.90kg	-3600K	3605.00
	900 (36")	14mm	12mm	5.40kg	-3620K	4500.00

High Tensile Bolt Cutters

Drop forged hardened chrome vanadium steel. Ideal for cutting both flat and round section steels. Hardened carbon steel jaws. Tubular steel handles with cushion grip for maximum operator comfort. Conform to **DIN 2076**.



Cut Type	Overall Length (mm)	Cutting Capacity		Weight each	Order Code KEN-592	Price/1 TB
		15°HRC	48°HRC			
Centre	300 (12")	13mm	8mm	4.00kg	-4200K	4635.00
	350 (14")	14mm	9mm	5.20kg	-4220K	9785.00
	1070 (42")	15mm	10mm	8.30kg	-4240K	20652.00

Heavy Duty Cable Cutters

For use when cutting aluminium and copper cable, using a slicing action. Manufactured from forged steel with PVC dipped handles. **Capacity:** 60mm².



Length (mm)	Weight each	Order Code KEN-558	Price/1 TB
250 (10")	516g	-8220K	1583.00

Lever-Type Cable Cutter

These cable cutters have heat treated cutting edges and are designed to cut copper/aluminium cables with minimal distortion. The soft grip handles are designed for user comfort whilst exerting force.

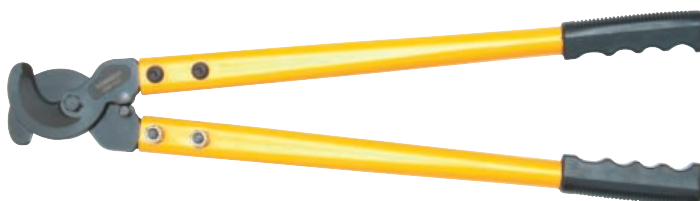

Cutting Capacity	Length (mm)	Weight each	Order Code KEN-558	Price/1 TB
18mm	380 (15")	3.4kg	-9400K	2717.00
25mm	550 (22")	3.4kg	-9410K	5157.00
40mm	820 (32")	3.4kg	-9420K	6541.00

Replacement Jaws



Centre Cut Jaws

To efficiently cut high tensile materials by directing the force being applied into a small area. For use on non-ferrous rods and bars, mild steel bolts etc.

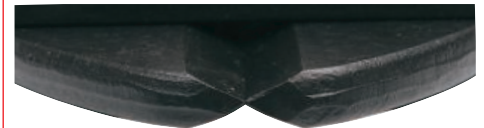

To Suit (mm)	Weight each	Order Code KEN-567	Price/1 TB
To Suit Low Tensile Cutters			
300 (12")	260g	-2920K	531.00
360 (14")	380g	-2940K	585.00
460 (18")	590g	-2960K	691.00
600 (24")	850g	-2980K	1751.00
760 (30")	1100g	-2990K	1906.00
900 (36")	2300g	-3000K	2833.00

Mini Bolt Cutters

Mini Cutters - Clipper Cut
 Manufactured from forged hardened steel, with spring return, allowing single-handed use. Compound action magnifies the pressure applied to the handle. Ensures a concentration of force between the jaws. Non-slip moulded plastic grip. Available with straight and bent jaws. For low tensile materials.



Overall length: 200mm (8").

Jaw Type	Cutting Capacity 735N/mm ² (45 tons/in ²)	Order Code KEN-592	Price/1 TB
Straight	3mm (1/8")	-0080K	685.00
Bent	3mm (1/8")	-0090K	850.00

Light Duty Cable Cutters

For cutting copper cable, plastic pipe, wooden dowels, rope cord and similar materials up to 10mm diameter. Precision ground and hardened stainless steel blades - 50~54HRC. Lightweight polypropylene handles with spring-loaded action, easy reach thumb catch convenient for right and left hand users.

Overall length: 165mm (6 1/2").
Cutting capacity: 10mm (3/8").



Cutting Capacity	Length (mm)	Weight each	Order Code KEN-558	Price/1 TB
10mm	165 (6 1/2")	130g	-5640K	471.00

Cable Cutters

Drop forged from high carbon micro alloyed steel induction hardened blades. Tough double tempered handles. For cutting copper cable up to 10mm diameter.



Length (mm)	Weight each	Order Code KEN-558	Price/1 TB
200 (8")	425g	-5680K	1288.00

HAND TOOLS

DRAWER CABINETS

KENNEDY *Small Parts*
QUALITY INDUSTRIAL TOOLING **Storage Cabinets**



Manufactured from heavy gauge steel, painted finish with impact resistant transparent polypropylene drawers, allowing contents to be viewed when the drawer is closed. The lip on the rear of the drawer allows it to be opened fully without falling out. The cabinets can be stacked or mounted to the wall to maximise use of storage space.

SENATOR *Small Parts*
QUALITY TOOLING **Storage Cabinets**



Manufactured from heavy gauge steel, painted finish with transparent plastic drawers, allows contents to be viewed when the drawer is closed. The lip on the rear of the drawer allows it to be opened fully without falling out. The cabinets can be stacked or mounted to the wall to maximise use of storage space.

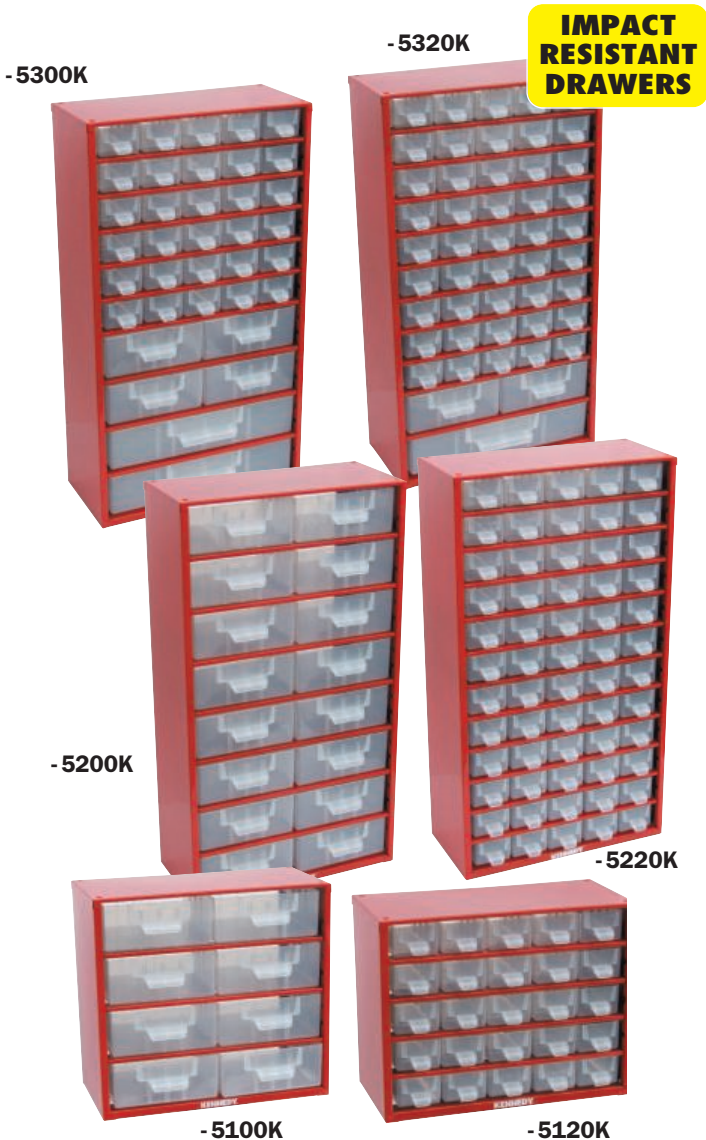

HAND TOOLS

Product Number	Cabinet/Drawers	Height (mm)	Width (mm)	Depth (mm)	Weight each	Order Code KEN-593	Price/1 TB
SCS008	Cabinet size 8 Drawers @	282 59	306 140	155 140	1.50kg	-5100K	2082.00
SCS025	Cabinet size 25 Drawers @	238 36.5	306 54	155 140	2.00kg	-5120K	2082.00
SCM016	Cabinet size 16 Drawers @	551 59	306 140	155 140	2.80kg	-5200K	3175.00
SCS060	Cabinet size 60 Drawers @	551 36.5	306 54	155 140	4.50kg	-5220K	3776.00
SCC036	Cabinet size 30 Drawers @	551 36.5	306 54	155 140	4.50kg	-5300K	3776.00
	4 Drawers @	59	140	140			
SCC048	2 Drawers @	59	280	140	4.20kg	-5320K	3776.00
	Cabinet size 45 Drawers @	551 36.5	306 54	155 140			
	1 Drawers @	59	280	140			

Drawers to Suit

Drawer Size	Height (mm)	Width (mm)	Depth (mm)	Weight each	Order Code KEN-593	Price/1 TB
Small	36.5	54	140	24g	-9600K	137.00
Medium	59	140	140	65g	-9620K	144.00
Large	59	280	140	154g	-9640K	308.00

Dividers to Suit

Drawer Size	Weight each	Order Code KEN-593	Price/1 TB
Small 50 x 29mm	19g	-9700K	101.00
Medium/Large 50 x 133mm	85g	-9720K	107.00

Product Number	Cabinet/Drawers	Height (mm)	Width (mm)	Depth (mm)	Weight each	Order Code SEN-593	Price/1 TB
SCM008	Cabinet size 8 Drawers @	282 59	306 140	155 140	1.50kg	-5100K	1788.00
SCS025	Cabinet size 25 Drawers @	238 36.5	306 54	155 140	2.00kg	-5120K	1854.00
SCM016	Cabinet size 16 Drawers @	551 59	306 140	155 140	2.80kg	-5200K	3040.00
SCS060	Cabinet size 60 Drawers @	551 36.5	306 54	155 140	4.50kg	-5220K	3306.00
SCC036	Cabinet size 30 Drawers @	551 36.5	306 54	155 140	4.50kg	-5300K	3239.00
	4 Drawers @	59	140	140			
SCC048	2 Drawers @	59	280	140	4.20kg	-5320K	2777.00
	Cabinet size 45 Drawers @	551 36.5	306 54	155 140			
	1 Drawers @	59	280	140			

Drawers to Suit

Drawer Size	Height (mm)	Width (mm)	Depth (mm)	Weight each	Order Code SEN-593	Price/1 TB
Small	36.5	54	140	13g	-9600K	100.00
Medium	59	140	140	80g	-9620K	129.00
Large	59	280	140	192g	-9640K	232.00

Dividers to Suit

Drawer Size	Weight each	Order Code SEN-593	Price/1 TB
Small 50 x 29mm	21g	-9700K	128.00
Medium/Large 50 x 133mm	104g	-9720K	141.00

PRODUCTS ARE ONLY AVAILABLE VIA YOUR DISTRIBUTOR

GROUP 593 TOOL POUCHES

KENNEDY *Nail Pouches - Leather*
QUALITY INDUSTRIAL TOOLING

Leather, two pockets and one loop.
 Double stitched seams with riveted corners for extra strength.
 Webbed nylon belt.



Size (mm)	Weight each	Order Code KEN-593	Price/1 TB
370 x 220	290g	-3240K	979.00

Leather, two pockets, one loop, deep pocket. Double stitched seams with riveted corners for extra strength.



Size (mm)	Weight each	Order Code KEN-593	Price/1 TB
360 x 250	370g	-3340K	1458.00

Leather Belts - Heavy Duty

Heavy duty natural split leather with heavy buckle and retaining loop.



Size (mm)	Weight each	Order Code KEN-593	Price/1 TB
1170 x 50	260g	-3000K	1893.00
1170 x 40	210g	-3020K	1457.00

Heavy duty oil tan belt with brass buckle and rivets for use with Kennedy tool pouches.



Size (mm)	Weight each	Order Code KEN-593	Price/1 TB
1170 x 50	309g	-3080K	732.00

Polyester & Nylon Belts

Adjustable webbing. Riveted for added strength and support.



Colour	Size (mm)	Weight each	Order Code KEN-593	Price/1 TB
Black	1200 x 50	120g	-3060K	613.00

Combination Pouches

Leather, made with one pocket, two loops and nail pouch. Belt not included.



Tools Not Included

Size (mm)	Weight each	Order Code KEN-593	Price/1 TB
280 x 270	310g	-3600K	2064.00

Manufactured from leather with a fully riveted double stitched construction. Chrome leather, five pockets and one loop. Belt not included.



Tools Not Included

Size (mm)	Weight each	Order Code KEN-593	Price/1 TB
210 x 250	340g	-3450K	1960.00

Leather, made with five pockets and one loop. Belt not included.



Tools Not Included

Size (mm)	Weight each	Order Code KEN-593	Price/1 TB
250 x 280	360g	-3460K	1927.00

Leather, made with five pockets, two loops, webbing belt and tape holder.



Tools Not Included

Size (mm)	Weight each	Order Code KEN-593	Price/1 TB
220 x 210	300g	-3470K	1055.00

HAND TOOLS

KENNEDY PROFESSIONAL **Nail Bag - Nylon**

Heavy duty polyester allows exceptional resistance to punctures or tears. Heavily stitched webbing belt complete with heavy duty double capped riveted clasp for added strength and support.



Size (mm)	Weight each	Order Code KEN-593	Price/1 TB
525 x 290	0.31kg	-3540K	369.00

Combination Tool Pouch

Double Nail Bag & Combination Tool Pouch

Heavy duty polyester allows exceptional resistance to punctures or tears. Heavily stitched webbing on belt loop and edges, and double capped riveted for added strength and support.



Size (mm)	Order Code KEN-593	Price/1 TB
270 x 200 x 50 (x2)	-3400K	2354.00
130 x 120 x 80 (x2)		
140 x 100 x 50 (x1)		

KENNEDY QUALITY INDUSTRIAL TOOLING **Double Tool Pouch**



10 Pocket 2 Loop Double Tool Pouch - Oil Tan

Manufactured from butt split leather. Fully riveted construction. 10 pockets with T-bar chain and spring clips. Belt supplied separately.



Size (mm)	Weight each	Order Code KEN-593	Price/1 TB
280 x 300	1.2kg	-3260K	2580.00

KENNEDY QUALITY INDUSTRIAL TOOLING **Combination Tool Pouches**

Leather, made with ten pockets, two loops, webbing belt and tape holder.



Tools Not Included

Size (mm)	Weight each	Order Code KEN-593	Price/1 TB
550 x 220	330g	-3500K	3141.00

Tool Pouches

Manufactured from leather. Fully riveted double titched construction. Chrome leather, two pockets and five loops. Belt not included.



Tools Not Included

Size (mm)	Weight each	Order Code KEN-593	Price/1 TB
290 x 200	300g	-3640K	1481.00

Tool Pouch - Large

4 Pocket 2 Loop Tool Pouch - Oil Tan

Large tool pouch with four pockets and two tool loops. Fully brass riveted construction. Manufactured from oil tanned leather.



Size (mm)	Weight each	Order Code KEN-593	Price/1 TB
300 x 230	965g	-3270K	1655.00

Leather, made with eight deep pockets, two nail pouches, two loops, webbing belt and tape holder.

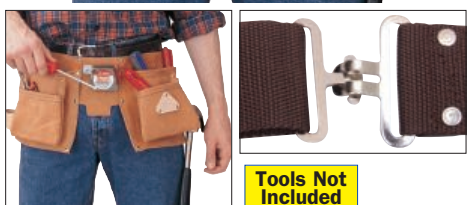

Tools Not Included

Size (mm)	Weight each	Order Code KEN-593	Price/1 TB
550 x 220	670g	-3510K	2243.00

Electrician's Tool Pouch

Manufactured from natural split leather, four pockets, seven tool loops, T-bar and chain, spring clip, tape pocket. Fully riveted construction. Belt not included.



Size (mm)	Weight each	Order Code KEN-593	Price/1 TB
200 x 260	410g	-3770K	1636.00

Nail & Tool Pouch - Large

3 Pocket 2 Loop Nail & Tool Pouch - Oil Tan

Large nail and tool pouch with three pockets and two tool loops. Fully brass riveted construction. Manufactured from oil tanned leather.



Size (mm)	Weight each	Order Code KEN-593	Price/1 TB
300 x 230	695g	-3280K	1491.00

HAND TOOLS

GROUP 593 TOOL POUCHES

KENNEDY *Spanner/Tool Holster*
QUALITY INDUSTRIAL TOOLING

Manufactured from natural split leather. Two spanner, tan leather. Reinforced joints. Belt not included.



Size (mm)	Weight each	Order Code	Price/1 TB
170 x 110	90g	KEN-593	568.00

Drill Holster

Manufactured from natural split leather, fitted with two additional tool loops and an adjustable drill safety strap, four slits for belt attachment, riveted construction. Tan leather with chuck key holder, adjustable retaining strap and one tool loop. Belt not included.



Size (mm)	Weight each	Order Code	Price/1 TB
300 x 200	250g	KEN-593	876.00

Plier/Wrench Holster

Leather-made with a 100 x 45 x 30mm pocket fully stitched and riveted at corners - double riveted at base. Two slots for belt attachment. Belt not included.



Size (mm)	Weight each	Order Code	Price/1 TB
75 x 230	90g	KEN-593	633.00

HAND TOOLS

Plier/Wrench Holster

Manufactured from natural split leather. 90mm tapered pouch with a 40 x 25mm opening. Fully riveted construction. Two slots for belt attachment. Belt not included.



Size (mm)	Weight each	Order Code	Price/1 TB
85 x 90	100g	KEN-593	402.00

Hammer Holster

With pivoting metal hammer loop, riveted onto natural split leather, with two slits for belt attachment. Belt not included.



Size (mm)	Weight each	Order Code	Price/1 TB
100 x 150	130g	KEN-593	258.00

Carpenter's Full Bib Apron

100% cotton drill, with cotton neck loop and ties. Two single stitched pockets.



Size (mm)	Weight each	Order Code	Price/1 TB
850 x 620	200g	KEN-593	502.00

Trimming Knife Holster

Manufactured from natural split leather. 100mm tapered pocket with a 40 x 20mm opening. Fully riveted construction. Two slits for belt attachment. Belt not included.



Size (mm)	Weight each	Order Code	Price/1 TB
60 x 190	80g	KEN-593	1590.00

Hammer & Tool Holster

Manufactured from natural split leather with four medium and one large leather tool loops. Riveted metal tool clip with metal T-bar and chain. Six slits for attaching to belt. Fully riveted construction. Belt not included.



Size (mm)	Weight each	Order Code	Price/1 TB
240 x 75	150g	KEN-593	789.00

KENNEDY PROFESSIONAL Mobile Phone Case

Polyester
Heavy duty nylon with stitched webbing trim. Front flap opening secured with velcro with optional webbing belt loop or stainless steel double capped riveted clip. 600 denier durable fabric hook and loop secured front flap. Complete with belt loop and clip.



Size (mm)	Weight each	Order Code	Price/1 TB
125 x 65 x 25	0.45g	KEN-593	263.00



KENNEDY *PVC-Coated Fibre Board*
QUALITY INDUSTRIAL TOOLING *Tool Case*

Waterproof, puncture resistant and rot proof PVC outer encasing rigid fibre board. Grained finish with 36 elasticated tool loops. Full zip around fastener. Black finish.



Tools Not Included

Size (mm)	Weight each	Order Code	Price/1 TB
315 x 30	350g	KEN-593	-0310K
			2396.00

PVC Multi-Tool Rolls

Waterproof, puncture resistant and rot proof PVC outer with heavy-duty nylon weave providing a high strength, abrasion resistant inner lining. With 8 flat tool pockets, webbed ties. Tools secured with flap cover.



Tools Not Included

Size (mm)	Weight each	Order Code	Price/1 TB
390 x 330	190g	KEN-593	-0370K
			684.00

Tear Resistant Tool Roll

Manufactured from heavy-duty tear resistant material with reinforced stitched edging. Two metal rings for hanging on to a wall when opened. 20 pockets, 18 elasticated tool loops are stitched on the inside. A velcro fastening secures the roll when shut.

Fitted with a riveted carry handle on the outside.



Tools Not Included

Size (mm)	Weight each	Order Code	Price/1 TB
600 x 540	502g	KEN-593	-0500K
			2185.00

PVC Double-Coated Nylon Multi-Tool Roll

Puncture resistant and rot proof PVC outer encasing heavy-duty nylon weave. 100% waterproof, easy to clean. With 12 flat, and two pleated pockets, one large end pouch divided into two with a press stud containing flap. Tools secured with flap cover. Leather tie with metal buckle.



Tools Not Included

Size (mm)	Weight each	Order Code	Price/1 TB
700 x 315	340g	KEN-593	-0520K
			1859.00

Chisel Roll

Waterproof chisel roll with 8 flat pockets. PVC coated cotton, with securing leather strap and metal buckle fastening. Tools secured with flap cover.

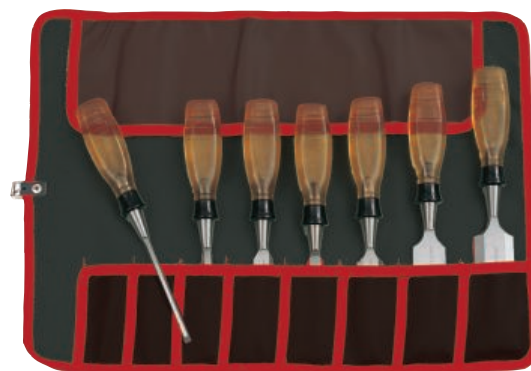

Tools Not Included

Size (mm)	Weight each	Order Code	Price/1 TB
370 x 490		KEN-593	-0490K
			514.00

HAND TOOLS

PVC-Coated Rayon Tool Rolls

Waterproof, puncture-resistant and rot proof PVC outer with soft non-scratch rayon inner to protect tools.

Multi - With 14 pockets. Tools secured by flap cover with two webbed ties.



Tools Not Included

Size (mm)	Weight each	Order Code	Price/1 TB
650 x 270	270g	KEN-593	-0870K
			776.00

Multi - With 12 pockets and two pouches. Tools secured by flap cover with two webbed ties.



Tools Not Included

Size (mm)	Weight each	Order Code	Price/1 TB
750 x 310	420g	KEN-593	-0880K
			1300.00

PVC-Coated Cotton Multi-Tool Rolls

Waterproof, puncture-resistant and rot proof PVC outer with medium duty, non-scratch cotton inner. With 15 pleated pockets, two webbed ties. Tools secured with flap cover.



Tools Not Included

Size (mm)	Weight each	Order Code	Price/1 TB
660 x 320	390g	KEN-593	-0440K
			743.00

Bench Stone Holder

To suit stone size 200 x 50 x 25mm.



Stone not included

Weight each	Order Code	Price/1 TB
120g	KEN-593	-7020K
		239.00

GROUP 593 TOOL BAGS

SENATOR QUALITY TOOLING Canvas Holdall

Manufactured from heavy duty water resistant canvas. Handles wrap underneath the bag for added strength, fitted with a heavy-duty zip.



Length (mm)	Weight each	Order Code SEN-593	Price/1 TB
460 (18")	250g	-0560K	514.00
610 (24")	335g	-0580K	686.00
760 (30")	360g	-0600K	720.00

PVC Tool Bag

The PVC makes the tool bag puncture resistant, waterproof and rot resistant. PVC holdall riveted leather handle and straps with metal buckles, fibre board base and top.



Length (mm)	Weight each	Order Code KEN-593	Price/1 TB
300 (12")	230g	-0100K	870.00

KENNEDY QUALITY INDUSTRIAL TOOLING Medium Weight Holdalls

Reinforced board base with four riveted plastic feet. Plastic zip fastening, webbing covered rope handles.



Length (mm)	Weight each	Order Code KEN-593	Price/1 TB
455 (18")	390g	-0110K	1040.00
610 (24")	500g	-0120K	1203.00

Heavy Duty PVC Nylon Coated Canvas Holdalls

Reinforced fibre board base with four riveted metal feet and zip fastening. Webbing covered rope handles and welded D-rings at either end.



Length (mm)	Weight each	Order Code KEN-593	Price/1 TB
455 (8")	670g	-0180K	1367.00
610 (24")	810g	-0240K	1442.00
760 (30")	590g	-0300K	1700.00

Jumbo Tool Bag

Heavy-duty double thickness canvas. Five internal pockets and a fibre board base with six riveted metal feet. Webbing handles and straps with plastic buckles.



Length (mm)	Weight each	Order Code KEN-593	Price/1 TB
610 (24")	1.50kg	-0060K	2733.00

Canvas Holdall

Heavy-duty water resistant. Canvas covered rope handles, fully stitched, wrap underneath bag for extra support. Three webbed straps with metal buckles for closing, two of which fully wrap around the bag to give extra support.



Length (mm)	Weight each	Order Code KEN-593	Price/1 TB
760 (30")	810g	-0080K	1012.00

HAND TOOLS

KENNEDY PROFESSIONAL Tool Bumbag with Shoulder Strap

Made of 600 denier durable fabric with adjustable shoulder and waist straps. It has a large internal compartment with 7 internal and 1 external pockets. Heavy duty zip and padded handles.



NEW



Tools Not Included

Size L x D x H (mm)	Order Code KEN-593	Price/1 TB
320 x 120 x 160	-0990K	550.00

Barn-Type Holdalls

Manufactured from butt split leather with wrap around leather handles. Leather fastening straps with metal buckles. Fully riveted construction. Reinforced on corners. Black finish.



Length (mm)	Weight each	Order Code KEN-593	Price/1 TB
400 (16")	1.40kg	-0620K	3863.00
535 (21")	1.80kg	-0630K	5149.00



KENNEDY PROFESSIONAL Heavy Duty Tool Caddy

600 denier durable fabric. Adjustable shoulder strap. Locking telescopic handle. 26 internal pockets. 12 external pockets. Large internal compartment. Padded handles and strap. Heavy duty zip.



Size (H x W x D)	Weight each	Order Code KEN-593	Price/1 TB
370 x 480 x 260mm	2kg	-0960K	2788.00

Heavy Duty Tool Bag

600 denier durable fabric. Adjustable shoulder strap. 13 external pockets. One large internal compartment. Main compartment can be divided into five pockets using removable divider. Heavy duty water-resistant base for extra strength. Padded handles and strap. Business-card holder and key strap. Heavy duty zip.



Tools Not Included

Size (H x W x D)	Weight each	Order Code KEN-593	Price/1 TB
280 x 340 x 200mm	1.8kg	-0980K	1476.00

Tool Trolley Rucksack

For technicians on the go; it can be pulled behind on wheels **OR** used as a backpack **OR** hand held.

Features include:

Extractable rear straps transform tool trolley into a functional backpack. Two internal double-sided reversible pallets, one with pouches for tools and the other with a soft padded area for computer notebook. Two front pouches for documents, accessories, measuring tape, spares etc. Large wheels for a stable carry-on. Telescopic handle. Fold down wheel cover when being used as a rucksack.



Tools Not Included

Size L x D x H (mm)	Weight each	Order Code KEN-593	Price/1 TB
340 x 150 x 440	4.3kg	-2530K	8498.00

Multi-Purpose Tool & Laptop Bag

Ideal for service engineers. Manufactured from a 600 denier fabric that is exceptionally durable and hard wearing. With large internal compartments (one padded for a laptop), pockets and elasticated tool holders it will help to ensure you have the right tool on site when you require it.

Features include:

Padded laptop holder. Business card holder. Adjustable shoulder strap. Padded handles and strap. Heavy duty zips and rubber feet.



Tools Not Included

Size (H x W x D)	Weight each	Order Code KEN-593	Price/1 TB
335 x 530 x 190mm	1.5kg	-5050K	1591.00

Heavy Duty-Tool Bag

600 denier durable fabric. Adjustable shoulder strap. 11 internal pockets. 17 external pockets. Large internal compartment. Padded handles and strap. Heavy duty zip.



Tools Not Included

Size (H x W x D)	Weight each	Order Code KEN-593	Price/1 TB
250 x 470 x 270mm	1.3kg	-0940K	931.00

Electrician's Tool Bag

Manufactured from heavy duty tear resistant material with reinforced stitched edging. Velcro fastening flap with soft touch carry handle and double webbed shoulder strap fixed with metal release clasps. Supplied with two small organiser cases which are stored in two outer pockets, two removable tool boards (one velcro fastened) are kept inside which have a unique tool storage securing system built-in.



Size L x D x H (mm)	Order Code KEN-593	Price/1 TB
320 x 340 x 125	-0560K	4646.00

HAND TOOLS

GROUP 593 TOOL CASES

KENNEDY Heavy Duty Aluminium Case
QUALITY INDUSTRIAL TOOLING

High strength, impact resistant case. Reinforced edges and hinges. Rubber padded handle for comfort. Two fitted and hinged tool boards with elasticated tool retaining loops, two expandable document pockets and divided storage compartment. Double locking with two keys.



Size (mm)	Weight each	Order Code	Price/1 TB
480 x 360 x 185	2.60kg	KEN-593 -2650K	22809.00
Spares		Order Code	Price/1 TB
Locks & Keys to suit		-7605K	1161.00
'D' Shape Case Handle to suit		-7610K	1161.00
Upper Tool Board to suit		-7660K	2369.00
Lower Tool Board to suit		-7662K	2369.00

Tools Not Included



HAND TOOLS

Impact Resistant Plastic Case

High strength ribbed double-wall constructed case. Two fitted hinged tool boards with elasticated tool retaining loops, four repositionable dividers in the bottom compartment, expandable document pocket in the lid and two removable small parts trays. Double locking with two keys.



Size (mm)	Weight each	Order Code	Price/1 TB
465 x 350 x 200	2.85kg	KEN-593 -2500K	15449.00
Spares		Order Code	Price/1 TB
Locks & Keys to suit		-7602K	2575.00
'D' Shape Case Handle to suit		-7601K	1161.00
Dividers to suit		-7603K	979.00
Tool Board to suit		-7654K	1957.00

Tools Not Included



KENNEDY PROFESSIONAL Service Case

Hard wearing cordura with nylon reinforced webbing handles. Two tool boards and unique repositionable tool retaining system, ceramic sheath for hot soldering irons and three press stud pockets. Zippable.



Size (mm)	Weight each	Order Code	Price/1 TB
450 x 330 x 80	2.10kg	KEN-593 -2850K	5863.00

Tools Not Included



KENNEDY *Aluminium Reinforced Case*
QUALITY INDUSTRIAL TOOLING

Impact resistant case. Two removable tool boards with elasticated tool retaining loops, one with document pocket, divided storage compartment. Double locking with two keys.



Tools Not Included



Size (mm)	Weight each	Order Code	Price/1 TB
445 x 340 x 190	2.85kg	KEN-593	-2550K 13624.00
Spares		Order Code	Price/1 TB
'D' Shape Case Handle to suit		-7604K	773.00
Locks & Keys to suit		-7605K	1161.00
Upper Tool Board to suit		-7656K	1858.00
Lower Tool Board to suit		-7658K	1964.00

Impact Resistant Service Case

Ribbed high strength plastic case with aluminium reinforced trim. Two fitted and hinged tool boards with elasticated tool retaining loops. Lockable with two keys. Padded carry handle.



Tools Not Included



Size (mm)	Weight each	Order Code	Price/1 TB
430 x 340 x 160	2.95kg	KEN-593	-2450K 9972.00
Spares		Order Code	Price/1 TB
Plastic Catch to suit		-7606K	773.00
Locks with Keys to suit		-7609K	979.00
'D' Shape Case Handle to suit		-7612K	1545.00
Upper Tool Board to suit		-7664K	2059.00
Lower Tool Board to suit		-7666K	2059.00

Polypropylene Moulded Tool Case

The polypropylene moulded case material makes the case extremely resistant against chemical corrosion, shock, high and low temperature. The injection technique ensures constant material thickness, even in the corners. Large and thick aluminium trim, makes the case ideal for daily, heavy duty use. The case can accommodate up to three tool pallets.

Features include:

- 2x metal lid safety support stays.
- 2x metal locks with keys.
- 3x metal hinges for maximum strength.
- Ergonomic handle, rubber coated grip.
- Address label.



Size L x D x H (mm)	Weight each	Order Code	Price/1 TB
430 x 340 x 156	5.5kg	KEN-593	-2510K 13389.00

PRODUCTS ARE ONLY AVAILABLE VIA YOUR DISTRIBUTOR

HAND TOOLS

GROUP 593 TOOL CASES

KENNEDY *Heavy Duty Aluminium Tool Case*
QUALITY INDUSTRIAL TOOLING

Manufactured from composite aluminium and rubber resin which is normally used in the automotive industry. Chromed steel hinges with lid support mechanism, two chromed steel locks with keys, a heavy duty plastic handle and four rubber feet. Inside are two secured hinged tool boards, each with 31 elasticated tool loops, an expandable document compartment, two small organisers and a customisable storage compartment with repositional dividers.



Tools Not Included

Size (mm)	Weight each	Order Code	Price/1 TB
466 x 340 x 190	5.5kg	KEN-593	19861.00

Spares	Order Code	Price/1 TB
'D' Shape Case Handle to suit	-7601K	1161.00
Locks with Keys to suit	-7607K	1288.00
Upper/Lower Tool Board to suit	-7668K	2318.00

HAND TOOLS

Service Engineer's Flight Case

Manufactured from high impact double walled polyethylene shell, corrosion-resistant and aluminium reinforced. Full length heavy duty piano hinges and trim. Two expandable document pockets, two hinged and fitted tool boards with elasticated tool retaining loops. Shockproof, bottom storage tray with fixed compartments and four small component boxes. The two 38mm wide rubber wheels and retractable telescopic aluminium handle allows the case to be moved when fully loaded with the minimum of effort. Double locking with two keys. Strong enough to be used to transport tools when travelling by aircraft.



Tools Not Included

Size (mm)	Weight each	Order Code	Price/1 TB
485 x 370 x 190	5.7kg	KEN-593	20679.00

Spares	Order Code	Price/1 TB
Telescopic Handle & Wheel Set to suit	-7600K	5665.00
'D' Shape Case Handle to suit	-7601K	1161.00
Locks & Keys to suit	-7602K	2575.00
Upper Tool Board to suit	-7650K	2593.00
Lower Tool Board to suit	-7652K	2452.00



KENNEDY *High Impact*
QUALITY INDUSTRIAL TOOLING *Resistant Tool Case*

Manufactured from composite aluminium and rubber resin which is normally used in the automotive industry. Chromed steel hinges with lid support mechanism, two chromed steel locks with keys, a heavy duty plastic handle and four rubber feet. Inside are two secured hinged tool boards, each with 31 elasticated tool loops, an expandable document compartment, two small organisers and a customisable storage compartment with repositional dividers.



Tools Not Included



Size (mm)	Weight each	Order Code	Price/1 TB
470 x 390 x 347	6.5kg	KEN-593	35072.00

Spares	Order Code	Price/1 TB
'D' Shape Case Handle to suit	KEN-567	
Locks with Keys to suit	-7601K	1161.00
Upper Tool Board to suit	-7608K	2833.00
Lower Tool Board to suit	-7670K	2575.00
Telescopic Handle & Wheel Set to suit	-7672K	2472.00
	-7700K	6179.00

Technical Service Tool Case

Constructed from impact and temperature resistant injection moulded high thickness polypropylene. The case has a large thick aluminium trim with a strength maximising triple metal hinge, it is highly functional with a significant load carrying capability but has a classy appearance to suit the technicians image.

Features include:

Injection moulded high thickness polypropylene. Telescopic handle and heavy duty rubber wheels. Two removable tool trays. Storage area with removable dividers. Two clasps with key locks.



Size L x D x H (mm)	Weight each	Order Code	Price/1 TB
465 x 352 x 215	7.00kg	KEN-593	11845.00

PRODUCTS ARE ONLY AVAILABLE VIA YOUR DISTRIBUTOR

HAND TOOLS

GROUP 593 TOOL CASES

SENATOR QUALITY TOOLING *Service Engineer's Aluminium Tool Case*

Heavy duty case for tool storage, ideal for the mobile service-engineer. Offers the storage of many tools with the professional look of a briefcase. Silver aluminium with reinforced edges and corners. Internal base compartment is fitted with adjustable dividers to offer choice of sizes. Removable rigid tool board stored in the lid with 17 pockets of various sizes. Supplied with fixed handle and two security locks and keys.



Size (mm)	Weight each	Order Code	Price/1 TB
457 x 330 x 150	3.00kg	SEN-593 -4400K	1983.00

Executive Engineer's Aluminium Tool Case



Large, lightweight case for tool storage, ideal for the mobile engineer. Offers the storage and portability of a large amount of tooling with the professional look of a briefcase. Black aluminium case with silver reinforced edges and corners. Internal base compartment is fitted with adjustable dividers to offer choice of sizes. Removable rigid tool board stored in the lid with 17 pockets of various sizes. 1" wide, length adjustable lightweight nylon shoulder strap with rubber shoulder protector for added comfort. Supplied with fixed handle and two security locks and keys.



Size (mm)	Weight each	Order Code	Price/1 TB
457 x 330 x 150	5.70kg	SEN-593 -4360K	2833.00

HAND TOOLS

Cantilever Aluminium Tool Case

Heavy duty case for tool storage, ideal for the mobile technician. Offers the storage and portability of many tools with the professional look of a briefcase. Silver aluminium with reinforced edges and corners. Concealed cantilever mechanism. Large base compartment with four cantilever trays to make all contents instantly available. Compartment dividers are adjustable to offer choice of sizes. 1" wide, length adjustable lightweight nylon shoulder strap, with rubber shoulder protector for added comfort. Supplied with fixed handle and two security locks and keys.



Reinforced edges and corners

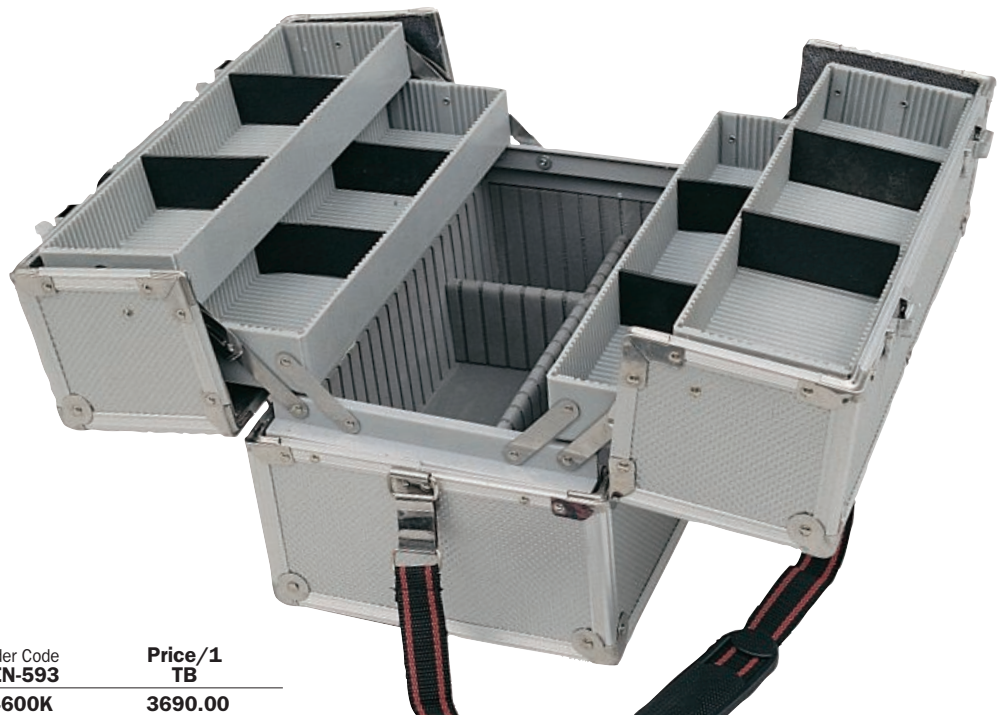

Size (mm)	Weight each	Order Code	Price/1 TB
360 x 220 x 245	3.10kg	SEN-593 -4600K	3690.00

KENNEDY *Power Tool Case*
QUALITY INDUSTRIAL TOOLING

Sturdy plastic case, suitable for a variety of tools, such as angle grinders, honing machines, drills, planes, sanders, etc.



Size (mm)	Order Code	Price/1 TB
420 x 260 x 160	KEN-593 -1020K	821.00

Tote Tool Organisers

Multi-purpose tote tray organisers are an ideal way to store and transport tools. The tote provides two deep trays for storage, built-in tool holders and a ribbed handle for extra grip.

Small: 392 x 281 x 110mm.
Large: 520 x 340 x 200mm.



Tools Not Included

Size	Weight each	Order Code	Price/1 TB
Small	410g	KEN-593 -2050K	274.00
Large	870g	-2070K	603.00

Steel Tool Tidy

Made from heavy gauge steel with double folded seams. For storing and transporting portable power tools and other items that require an industrial case for protection.



Size (mm)	Weight each	Order Code	Price/1 TB
270 x 115 x 400	1.40kg	KEN-593 -1000K	1494.00

Tool Box with Tote

Manufactured from impact resistant high-density plastic. Internal eight compartment tote tray. Features moulded metric rule on the lid, lid locking clasps and sturdy plastic handle that also locks lid shut when lifting. Padlock hole and piano hinges.



Size (mm)	Order Code	Price/1 TB
445 x 240 x 220	KEN-593 -2300K	1067.00

Tool Box With Tote & Organiser

Made from impact resistant high-density plastic. Internal eight compartment tote tray with retractable carry handle and stacking 16-compartment organiser, moulded metric scale on the lid, lid locking clasps and sturdy plastic handle that also locks lid shut when lifting. With lock hasp and piano hinge.



Size (mm)	Order Code	Price/1 TB
480 x 240 x 260	KEN-593 -2320K	1586.00

YAMOTO Heavy Duty Site Tool Boxes

Powder coated. Soft grip carrying handle and lightweight design. The black plastic overrides add to the overall ruggedness helping to prevent damage to the box or items around it. The lid has 'V' section to allow measuring and cutting short lengths of pipe. There is a tote tray for smaller items. Fitted with heavy-duty metal latches designed to stay closed even when in transit.



Width (mm)	Depth (mm)	Height (mm)	Order Code	Price/1 TB
470	238	178	YMT-593 -1420K	1586.00
582	298	255	-1440K	2133.00
2 Piece Set - (1 of each above)				-1400K 3225.00

HAND TOOLS

GROUP 593 TOOL BOXES

KENNEDY Multi-Utility Storage Box
QUALITY INDUSTRIAL TOOLING

A lightweight high capacity injection moulded polypropylene box for tough, heavy duty use. Water-resistant design and integral lifting grips on both sides. The lid features a full length steel pin hinge with 'positive pressure' cam style clasp mechanism that seals the case to create a water-resistant closure. Also features integral trolley suit-case style wheels and a pull-out handle, a robust fold flat carry handle and a slide out clear ID/nameplate holder. Shock-resistant and corrosion-proof. Moulded padlocking hasp and stacking locators.



Tools Not Included



Size (mm)	Order Code	Price/1 TB
780 x 410 x 330mm	KEN-593 -1600K	10382.00

Mobile Tool Box

Sturdy mobile tool box with a large lower storage area for power tools, etc. The tool box has an integral handle slides out for ease of transport, two nested tote trays for smaller tools. The lockable lid has two storage compartments for fixings.

Tools Not Included



Size (mm)	Order Code	Price/1 TB
580 x 370 x 480mm	KEN-593 -2000K	4371.00

4-Drawer Tool Chest

Manufactured from high impact co-polymer polypropylene.



Metric graduated V-groove in the lid securely holds workpiece while being cut.



Tools Not Included

Features four sliding drawers enclosed with a slide clasp front panel to prevent opening whilst in transit. Top carry handle with soft touch grip zone and large locking clasps. Front cover panel and lid have aligning padlock hole for added security.

Size (mm)	Order Code	Price/1 TB
450 x 250 x 325	KEN-593 -1500K	2569.00

Tool Box with Tote & Wheels

Recessed rigid handle for tilting box onto wheels for easy transportation. Large clasps to lock lid when in transit/storage and padlock hole for security. Recessed carrying handle allows stacking. Five-compartment tote tray also features opaque lids on the two end compartments with moulded snap clasps to prevent accidental opening.

Weight: 3.30kg.



Size (mm)	Order Code	Price/1 TB
645 x 280 x 300	KEN-593 -2340K	2049.00

KENNEDY 10-Compartment Storage Trays
QUALITY INDUSTRIAL TOOLING

Made from tough polypropylene. Service cases have 10 equal compartments. Lids have positive catches and are semi-transparent to view their contents.



-6040K



Overall Length	Overall Width	Overall Depth	Weight each	Order Code	Price/1 TB
240mm	178mm	36mm	0.2kg	-6000K	274.00
200mm	130mm	45mm	180g	-6040K	301.00

Professional Service Case

Suitable for transporting and storing smaller items. Manufactured from hi-density industrial strength plastic with opaque lid for viewing contents. Slide clasp-locking mechanism to prevent opening while in transit/storage. Lid and base feature two aligning padlock holes to accept padlocks with shackle diameters up to 5.8mm. The lids have three hinges for strength and durability. Eight fixed compartments supplied with dividers to make up to 16 sections.

Dimensions (W x D x H):
380 x 60 x 335mm.



Height (mm)	Width (mm)	Depth (mm)	Order Code	Price/1 TB
380	60	335	-2400K	821.00

Service Case Organiser

Robust stacking unit for containing four lockable organiser cases, which lift and slide out. The expandable system allows units to be attached on top or side by side. Cases have translucent lid for selecting contents and multi-positional compartment separators. Used for storing up to four service cases.

Dimensions (L x W x H): 425 x 350 x 375mm.

Maximum load: 6kg.
It is recommended that no more than three organisers should be stacked at one time.



SERVICE CASES AVAILABLE SEPARATELY (See above)

Height (mm)	Width (mm)	Depth (mm)	Order Code	Price/1 TB
425	350	375	-2380K	5000.00



KENNEDY 2-in-1 Rolling Tool Box
QUALITY INDUSTRIAL TOOLING

Mobile storage solution manufactured from impact resistant plastic, making it ideal for heavy duty use. Features include - soft bi-material handles, padlock eyes, heavy-duty steel catches, side handles for dual lifting, high strength wheels with rubber tyres, integrated footplate to aid tilting, reinforced corners, and lock-in latches to secure the two tool boxes together.



Retractable telescopic handle & removable lid and tote tray



Boxes stack and lock together when transporting

Description	Weight	Order Code	Price/1 TB
2-in-1 Rolling Toolbox	11.3kg	-9810K	5739.00

Mobile Tool Cabinet

Manufactured from high impact co-polymer polypropylene. Large tilt opening parts bin. Sliding drawers with locking mechanism to prevent the drawer opening whilst in transit. Top carry handle with soft touch grip zone and large locking clasps. Internal four compartment tote tray. Top box and parts bin both feature aligning holes to suit padlocks with shackle diameters of up to 7.4mm. Metric graduated V-groove in the lid securely holds work piece while being cut. Trolley handle is height adjustable. Rear 'H' hooks for storing extension leads and large wheels for easy movement.

Size (W x D x H):
490 x 330 x 720mm.



Size (mm)	Order Code	Price/1 TB
490 x 330 x 720	-1800K	5109.00

4-Drawer Parts Cabinet

Manufactured from hi-impact co-polymer polypropylene with opaque drawers for viewing contents. Three section top compartment with opaque lid and moulded snap clasps to prevent accidental opening. Each internal sliding transparent drawer features three removable dividers and locking mechanism to prevent the drawer opening whilst in transit. Recessed top carry handle and locating lugs allows stacking of multiple cabinets.

Dimensions (W x D x H):
390 x 200 x 340mm.



Height (mm)	Width (mm)	Depth (mm)	Order Code	Price/1 TB
390	200	340	-1760K	1996.00

HAND TOOLS

GROUP 593 TOOL BOXES

KENNEDY PROFESSIONAL Cantilever

Heavy gauge steel with all-welded construction for continuous industrial use. Durable corrosion-resistant two part epoxy powder coat finish. Fully enclosed cantilever mechanism for added security. Quick release lid clasps with padlock hole for security. Two-piece cantilever lids that can be padlocked for additional security (padlock not included). Full width piano hinges provide rigidity and strength. Large base compartment (450 x 260 x 170mm) with four cantilever trays for additional storage. The cantilever action of the top trays makes tray contents instantly available. Supplied with fixed carry handle on the lid.

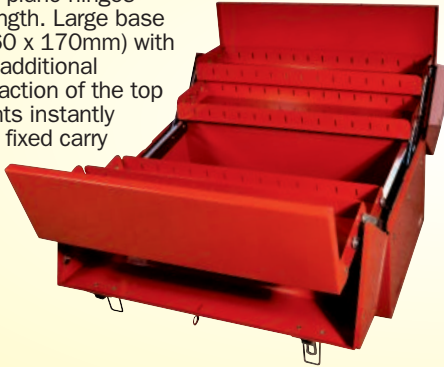

Width (mm)	Depth (mm)	Height (mm)	Weight each	Order Code KEN-594	Price/1 TB
459	255	333	9.10kg	-0140K	5856.00

Heavy Duty Tool Boxes

Heavy gauge steel, all welded construction. Durable and corrosion resistant two-part epoxy powder paint finish. With quick release lid clasps, padlock hasps and textured carry handles. Full width piano hinges provide rigidity and strength, ensuring smooth operation and additional security. Removable tote tray for smaller tools and components. Can be padlocked for additional security (padlock not included). Supplied with fixed carry handle on the lid.



Width (mm)	Depth (mm)	Height (mm)	Weight each	Order Code KEN-594	Price/1 TB
483	180	180	3.65kg	-0040K	2338.00
508	218	243	6.35kg	-0060K	3092.00

KENNEDY QUALITY INDUSTRIAL TOOLING Industrial Cantilever Tool Boxes

Manufactured from industrial quality steel with all welded construction. Durable corrosion-resistant two-part epoxy powder coat finish. Two piece cantilever lids with padlock hole for additional security. Large base compartment with four partitioned, instant access cantilever trays for additional storage. Full width carry handle also automatically closes trays when lifting.



Overall Length	Overall Width	Overall Depth	Weight each	Order Code KEN-593	Price/1 TB
430mm	205mm	205mm	5.30kg	-1170K	2405.00
560mm	205mm	205mm	6.10kg	-1210K	2841.00

Barn-Type Tool Boxes

Manufactured from heavy gauge steel of rigid construction for continuous industrial use. Large base compartment for larger items and removable tote tray for smaller and most used items. Hard wearing cellulose paint finish. Two piece lid doors that overlap with padlock hole for added security. Full width piano hinges provide rigidity and strength. Supplied with fixed carry handle on the lid.



Overall Length	Overall Width	Overall Depth	Weight each	Order Code KEN-593	Price/1 TB
355mm	205mm	185mm	3.00kg	-2140K	1476.00
480mm	205mm	185mm	4.40kg	-2190K	1914.00
610mm	205mm	185mm	5.10kg	-2240K	2133.00

SENATOR QUALITY TOOLING Cantilever Tool Boxes

Steel construction with two piece cantilever lids with padlock hole for additional security. Large base compartment with four easy access cantilever trays for additional storage. The full width carry handle automatically closes the trays when lifting.



Size (mm)	Order Code SEN-593	Price/1 TB
430 (17")	-1370K	1768.00
530 (21")	-1410K	1920.00

Barn-Type Tool Box

Steel construction with base compartment for larger items and removable upper tray for smaller, most used items.



Size (mm)	Order Code SEN-593	Price/1 TB
355 (14")	-1540K	1497.00

HAND TOOLS



KENNEDY PROFESSIONAL **Portable Tool Chests**

Manufactured from heavy gauge steel with all welded construction. Durable and corrosion-resistant two part epoxy powder paint finish. With quick release lid clasps, padlock hasps and textured carry handles. Full width piano hinges provide rigidity and strength, ensuring smooth operation and additional security.

2 Drawer

Two full-length drawers with rigid aluminium lipped handles. Automatically locks the drawers when the lid is closed, to prevent accidental opening.

Drawer size: 508 x 190 x 76mm.

3 Drawer

Three full-length drawers with rigid aluminium edged handles. Fully lockable unit with a handle on the top and a carry handle on each end. The lid automatically locks all of the closed drawers when lowered to prevent opening.

Overall dimensions (W x H x D): 520 x 340 x 215mm.

Drawer sizes: 2@ 460 x 180 x 55mm. 1@ 460 x 180 x 75mm.



Width (mm)	Depth (mm)	Height (mm)	Weight each	Order Code	Price/1 TB
534	218	288	10.4kg	KEN-594 -0100K	6923.00

Width (mm)	Depth (mm)	Height (mm)	Weight each	Order Code	Price/1 TB
520	215	340	10.4kg	KEN-594 -0120K	8495.00

Stainless Steel Tool Chest & Roller Cabinets

Manufactured from heavy gauge stainless steel with double wall construction side panels and welded joints for added rigidity. Quick release smooth running ball bearing drawer slides. Fully locking. 125 x 50mm heavy-duty extra strong castors, fitted with two brakes. Castors are rated to 100kg capacity standing load per castor. Drawer loads should be evenly distributed. Available in Grade 430 or Grade 304 stainless steel.

4 Drawer Cabinets

Drawer sizes (W x D x H): 4@ 597 x 428 x 90mm.

Overall dimensions: 673 x 470 x 513mm.

7 Drawer Roller Cabinets

Drawer sizes (W x D x H):

5@ 597 x 428 x 90mm.

1@ 597 x 428 x 135mm.

1@ 597 x 428 x 180mm.

Overall dimensions:

683 x 480 x 887mm.



NEW

Grade 430

Description	Order Code	Price/1 TB
Tool Chest	-0003A	35000.00
Roller Cabinet	-0004A	49000.00

Grade 304

Description	Order Code	Price/1 TB
Tool Chest	-1540K	40170.00
Roller Cabinet	-6020K	58710.00

Spares	Order Code
Lock	SPR-567-7210K
Key Blank	SPR-567-7320K
Draw Slide	SPR-567-7040K
Castors	SPR-567-6920K
Top Mat	SPR-567-7540K
Draw Liner	SPR-567-6610K

For Prices see Page 583

PRODUCTS ARE ONLY AVAILABLE VIA YOUR DISTRIBUTOR

GROUP 594 ROLLER CABINETS & TOOL CHESTS

KENNEDY PROFESSIONAL Roller Cabinets & Tool Chests



Our Ultimate Range of Tool Storage – Combines Maximum Capacity with a Superior Finish

Robust and hardwearing, this range is made from a two part construction with strong steel inner walls and reinforced back panels for added security. The angled corners protect against mobility strains or cracks and preserve product shape for longer. These items feature anti-rust and solvent resistant powder coat finish. Fully opening drawers with classic design pulls to allow easy access with a drawer weight capacity of 40-45kg. The increased drawer load capacities allows storage of most tools and can be fully loaded.

Security

Top lid fitted with gas struts for safe and easy access. Full height rear locking mechanism for greater security.

Mobility

Strong ergonomic side handles, can fit to either side of unit. 125mm diameter castors with brakes, absorbs shock and can support heavy loads.

Design

Anti - rust and solvent resistant powder coat finish, maintains paintwork and protects against scratches. Perforated sides optimise space with easy to install accessories and tool holders. 45° angled corners protects against mobility strains and cracks, plus preserves unit shape. Plastic bumpers on each corner protects against impact. Non-slip 10mm EVA top mat prevents damage and protects tools. ABS top tray available.

Drawers

Fully opening allowing greater access. Auto return magnets secure drawers into place. Full width individual catches only allows one drawer to open at a time, prevents cabinet from tipping. 3.0mm EVA liners maintains paintwork and protects tools. 45mm ball bearing slides give good drawer stability and smooth action - even under load.

Top Chest

6 Drawer Size (WxDxH):
3@ 170x400x75mm
3@ 570x400x75mm

Roller Cabinets

5 Drawer Size (WxDxH):
1@ 570x400x75mm
4@ 570x400x155mm

7 Drawer Size (WxDxH):
5@ 570x400x75mm
2@ 570x400x155mm

Total drawer load capacity:

Tool Chests: 255kg.
Roller Cabinets: 290kg.



Roller Cabinet only



HAND TOOLS

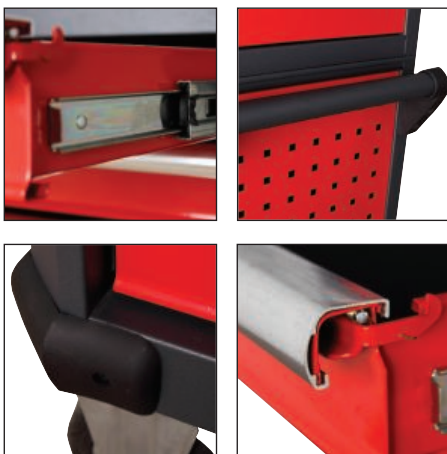

Accessories
Page 574

Top Chest

Number of Drawers	Width (mm)	Depth (mm)	Height (mm)	Order Code	Price/1 TB
6	710	465	455	KEN-594	16500.00

Roller Cabinets

Number of Drawers	Width (mm)	Depth (mm)	Height (mm)	Order Code	Price/1 TB
5	710	465	845	KEN-594	38000.00
7	710	465	845	-2340K	44000.00

KENNEDY Roller Cabinets & Tool Chests
QUALITY INDUSTRIAL TOOLING

NEW



INDUSTRIAL

Our High-end Industrial Range – Robust Enough for the Demands of Every Workplace

This range has been made with the heavy industrial user in mind. These items feature full width top chests and full height cabinets with alloy style castors. All units are finished with anti-rust and solvent resistant powder coat paint. Made from robust steel with inner walls and reinforced back panels. All corners are angled to maintain product shape and protect cabinet during transportation. This range features fully opening drawers with classic design pulls to allow easy access. Our Kennedy logo is pressed into the top chest lid and cabinet bottom drawer.

Security

Top lid fitted with 2 steel stays lock into position - option of gas struts available. Full height rear locking mechanism for greater security.

Mobility

Strong ergonomic side handles (Roller Cabinets) can fit to either side of unit. Chrome side handles with comfort grip (Tool Chest). For ease when transporting unit. 125mm diameter castors with brakes, absorbs shock and can support heavy loads.

Design

Anti-rust and solvent resistant powder coat finish maintains paintwork and protects against scratches. Perforated sides optimise space with easy to install accessories and tool holders available. 45° angled corners protects against mobility strains and cracks, plus reserves unit shape. Steel inner walls for added strength and extra rigidity. Non-slip 10mm EVA top mat prevents damage and protects tools. ABS top tray available.

Drawers

Fully opening allowing greater access. Auto return magnets secure drawers into place. Individual latches prevents unexpected opening of drawers when repositioning. 2.5mm EVA liners maintains paintwork and protects tools. 45mm Ball bearing slides give good drawer stability and smooth action - even under load.

Top Chest

3 Drawer Size (WxDxH):
3@ 170x400x75mm

6 Drawer Size (WxDxH):
3@ 170x400x75mm
3@ 570x400x75mm

12 Drawer Size (WxDxH):
9@ 170x400x50mm
2@ 570x400x50mm
1@ 570x400x75mm

Roller Cabinets

5 Drawer Size (WxDxH):
1@ 570x400x75mm
4@ 570x400x155mm

7 Drawer Size (WxDxH):
5@ 570x400x75mm
2@ 570x400x155mm

Total drawer load capacity:

Tool Chests: 195kg.

Roller Cabinets: 220kg.

450kg Load Capacity
(Static)

Roller Cabinet only



HAND TOOLS

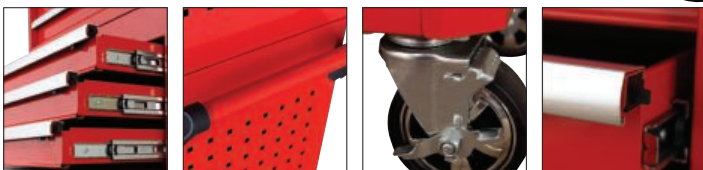

Accessories
Page 574

Top Chests

Number of Drawers	Width (mm)	Depth (mm)	Height (mm)	Order Code KEN-594	Price/1 TB
3	710	465	375	-2040K	13000.00
6	710	465	455	-2220K	14500.00
12	710	465	485	-2420K	25000.00

Roller Cabinets

Number of Drawers	Width (mm)	Depth (mm)	Height (mm)	Order Code KEN-594	Price/1 TB
5	710	465	845	-2120K	36000.00
7	710	465	845	-2320K	41000.00

PRODUCTS ARE ONLY AVAILABLE VIA YOUR DISTRIBUTOR

GROUP 594 ROLLER CABINETS & TOOL CHESTS

KENNEDY Select Range
QUALITY INDUSTRIAL TOOLING **Roller Cabinets**

Our High-end Industrial Range – Robust Enough for the Demands of Every Workplace
This range has been made with the heavy industrial user in mind. These items feature full width top chests and full height cabinets with alloy style castors. All units are finished with anti-rust and solvent resistant powder coat paint. Made from robust steel with inner walls and reinforced back panels. All corners are angled to maintain product shape and protect cabinet during transportation. This range features fully opening drawers with classic design pulls to allow easy access. Our Kennedy logo is pressed into the top chest lid and cabinet bottom drawer.

3 Drawer Roller Cabinet
3@ 570 x 400 x 75mm

INDUSTRIAL



NEW

450kg Load Capacity
(Static)

5 Drawer Roller Cabinet
1@ 570 x 400 x 75mm
4@ 570 x 400 x 155mm



NEW

450kg Load Capacity
(Static)

Number of Drawers	Width (mm)	Depth (mm)	Height (mm)	Order Code KEN-594	Price/1 TB
3	710	465	845	-2020K	26000.00
5	710	465	845	-2620K	38000.00



KENNEDY PROFESSIONAL

4 Piece Can Holder
Size: (WxDxH)
325x90x70mm



7 Piece Screwdriver Holder
Size: (WxDxH)
200x39x65mm



Side Tray
Size: (WxDxH)
300x120x60mm



7 Piece Hook Rack
Size: (WxDxH)
325x5x29mm



ABS Work Top Tray
Size: (WxDxH)
720x470x25mm



Multifunctional Tray
Size: (WxDxH)
320x90x120mm



Description	Order Code KEN-594	Price/1 TB
ABS Work Top Tray	-1580K	2350.00
4 Piece Can Holder	-1590K	750.00
7 Piece Hook Rack	-1610K	599.00
7 Piece Screwdriver	-1630K	450.00
Multifunctional Tray	-1650K	699.00
Side Tray	-1660K	999.00

320mm Paper Roll Holder
Size: (WxDxH)
20x30x270mm



Gas Struts



Waste Bin
Size: (WxDxH)
300x135x250mm

Tote Tray
Size (WxDxH):
440 x 175 x 85mm

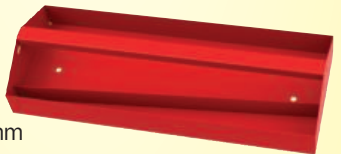

Description	Order Code KEN-594	Price/1 TB
Paper Roll Holder	-1560K	999.00
Tote Tray	-1640K	650.00
Waste Bin	-1670K	1350.00
Gas Struts	-6600K	599.00

HAND TOOLS

YAMOTO *Roller Cabinets & Tool Chests*

Our Mid-Range of Tool Storage – Modern Design that’s Sturdy, Stylish and Secure
 Introducing our trade-pro tool storage range. This range comprises of full height cabinets with a stylish and modern design with ergonomic drawer pulls. These feature 35mm ball bearing slides and has the highest drawer load capacities within our Yamoto range. Made to be sturdy these have steel inner walls with a pressed steel back strengthener with angled front corners to prolong cabinet life.

Top Chest
6 Drawer Size (WxDxH):
 3@ 170x275x50mm
 2@ 570x275x50mm
 1@ 570x275x75mm

12 Drawer Size (WxDxH):
 9@ 170x400x50mm
 2@ 570x400x50mm
 1@ 570x400x75mm

Roller Cabinets
3 Drawer Size (WxDxH):
 2@ 570x400x75mm
 4@ 570x400x155mm
5 Drawer Size (WxDxH):
 1@ 570x400x75mm
 4@ 570x400x155mm
7 Drawer Size (WxDxH):
 5@ 570x400x75mm
 2@ 570x400x155mm

Total drawer load capacity:
Tool Chests: 150kg.
Roller Cabinets: 210kg.

Top Chests

Number of Drawers	Width (mm)	Depth (mm)	Height (mm)	Order Code YMT-594	Price/1 TB
6	660	310	380	-1500K	14500.00
12	660	440	490	-1520K	23000.00

Roller Cabinets

Number of Drawers	Width (mm)	Depth (mm)	Height (mm)	Order Code YMT-594	Price/1 TB
3	680	460	860	-1600K	15000.00
5	680	460	860	-1620K	23500.00
7	680	460	860	-1640K	26500.00

SENATOR *Roller Cabinets & Tool Chests*
QUALITY TOOLING

Our Workshop, General Purpose Range – Entry Level Choice for Durability and Mobility
 The new Senator tool storage range is ideal for your workshop or the light industrial user. With an anti-rust and solvent resistant powder coat finish this range will stay looking new for longer. The top chest features corner protectors, reinforced lid and steel lid stays to protect from any impact or accidental slamming. The new ergonomic drawer pulls provide easy access to your tools. The new workshop range have 35mm ball bearing slides giving greater drawer weight capacities to store all your tools. These benefit from steel inner walls with a pressed steel back strengthener making them more robust and longer lasting.

Top Chest
3 Drawer Size (WxDxH):
 3@ 170x275x50mm
 3@ 570x275x50mm

Total drawer load capacity:
Tool Chests: 150kg.
Roller Cabinets: 210kg

Roller Cabinets
3 Drawer Size (WxDxH):
 3@ 570x400x60mm
 1@ 675x460x440mm
5 Drawer Size (WxDxH):
 1@ 570x400x60mm
 4@ 570x400x125mm
7 Drawer Size (WxDxH):
 5@ 570x400x60mm
 2@ 570x400x125mm

Top Chests

Number of Drawers	Width (mm)	Depth (mm)	Height (mm)	Order Code SEN-594	Price/1 TB
6	660	310	355	-1660K	13500.00

Roller Cabinets

Number of Drawers	Width (mm)	Depth (mm)	Height (mm)	Order Code SEN-594	Price/1 TB
3	680	460	725	-1530K	13500.00
5	680	460	725	-1550K	16500.00
7	680	460	725	-1570K	23000.00



Roller Cabinet only



Roller Cabinet only

HAND TOOLS

GROUP 594 ROLLER CABINETS & TOOL CHESTS

KENNEDY PROFESSIONAL Roller Cabinets



Manufactured from heavy gauge steel with double wall construction side panels and welded joints for added rigidity. Coated in a hard wearing epoxy powder. Fully opening drawers for extra accessibility. Quick release smooth running ball bearing drawer slides with double sliders on base drawer. Supplied with top mat and drawer liners. Fully locking. 125 x 50mm heavy-duty extra strong castors, fitted with two brakes. Overall dimensions: 890 x 690 x 460mm. Castors are rated to 100kg capacity standing load per castor. Drawer loads should be evenly distributed. Roller cabinets are not suitable for frequent relocation when loaded, and when moved should only ever be pushed.

3 Drawer
Internal drawer dimensions
bottom compartment (W x D x H):
610 x 430 x 355mm.

Drawers (W x D x H):
3@ 590 x 410 x 100mm.
Uses 16" drawer slides.

Spares	Order Code
Lock	SPR-567-7260K
Key Blank	SPR-567-7320K
Draw Slide	SPR-567-7040K
Castors	SPR-567-6920K
Top Mat	SPR-567-7560K
Draw Liner	SPR-567-6610K

For Prices see Page 583

5 Drawer
Drawers (W x D x H):
4@ 590 x 410 x 100mm.
1@ 590 x 410 x 200mm.

Uses 16" drawer slides.

Spares	Order Code
Lock	SPR-567-7210K
Key Blank	SPR-567-7320K
Draw Slide	SPR-567-7040K
Castors	SPR-567-6920K
Top Mat	SPR-567-7560K
Draw Liner	SPR-567-6610K

For Prices see Page 583



Colour	Width (mm)	Depth (mm)	Height (mm)	Weight each	Order Code	Price/1 TB
Red	690	460	890	44.0kg	KEN-594	25069.00

Colour	Width (mm)	Depth (mm)	Height (mm)	Weight each	Order Code	Price/1 TB
Red	690	460	890	44.0kg	KEN-594	32349.00

HAND TOOLS

7 Drawer
Drawers (W x D x H):
4@ 590 x 410 x 50mm. 2@ 590 x 410 x 100mm.
1@ 590 x 410 x 200mm.

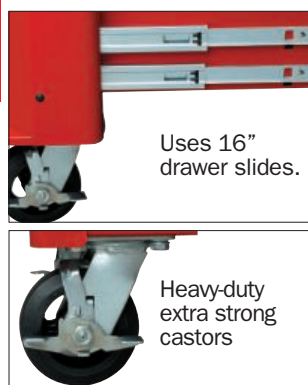

Uses 16" drawer slides.

Heavy-duty extra strong castors



Spares	Order Code
Lock	SPR-567-7210K
Key Blank	SPR-567-7320K
Draw Slide	SPR-567-7040K
Castors	SPR-567-6920K
Top Mat	SPR-567-7560K
Draw Liner	SPR-567-6610K

For Prices see Page 583

Colour	Width (mm)	Depth (mm)	Height (mm)	Weight each	Order Code	Price/1 TB
Red	690	460	890	53.0kg	KEN-594	31583.00

ABS Worktop to suit Standard Roller Cabinets

Designed to fit directly on to the top of most standard 3, 5, and 7 drawer roller cabinets including Kennedy, Yamoto, Senator, Britool, Proto etc. Provides a non-slip compartmentalised working space to hold tools and fasteners whilst protecting the paint finish of the roller cabinet itself. Manufactured from high impact ABS plastic.

Overall size (W x D): 695mm x 464mm
Size range of cabinets suited (W x D): 655mm to 690mm x 425mm to 460mm

NEW



Overall Size (mm)	Order Code	Price/1 TB
695 x 464	SPR-567	1288.00

ROLLER CABINETS & TOOL CHESTS

KENNEDY PROFESSIONAL Step-up Units

2 Drawer

Manufactured from heavy gauge steel, electro-coated enamel finish for superior appearance and protection. Steel panels in the drawers for extra rigidity, ball bearing drawer runners. Supplied with drawer liners and top mat.

Drawer sizes (W x D x H):

2@ 590.5 x 410 x 102mm.



Spares	Order Code
Lock	SPR-567-7210K
Key Blank	SPR-567-7320K
Draw Slide	SPR-567-7040K
Top Mat	SPR-567-7560K
Draw Liner	SPR-567-6610K

For Prices see Page 583

Colour	Width (mm)	Depth (mm)	Height (mm)	Weight each	Order Code KEN-594	Price/1 TB
Red	688	459	280	44.0kg	-5400K	12624.00

12 Drawer

Top compartment size (W x D x H):

660 x 150 x 90mm.

Drawer sizes (W x D x H):

6@ 125 x 410 x 50mm.
1@ 170 x 410 x 155mm.
2@ 130 x 410 x 75mm.
2@ 590 x 410 x 50mm.
1@ 590 x 410 x 100mm.

Uses 14" drawer slides.
Type B lid stays.



EXTRA DEEP

Spares	Order Code
Lock	SPR-567-7240K
Key Blank	SPR-567-7320K
Draw Slide	SPR-567-7040K
Lid Stays	SPR-567-6950K
Draw Liner	SPR-567-6610K

For Prices see Page 583

Colour	Width (mm)	Depth (mm)	Height (mm)	Weight each	Order Code KEN-594	Price/1 TB
Red	690	445	490	48.0kg	-5280K	23124.00

Tool Chests

3 Drawer

Top compartment size:

90 x 660 x 150mm.

Drawer sizes (W x D x H):

1@ 590 x 285 x 50mm.
2@ 590 x 285 x 100mm.



Spares	Order Code
Lock	SPR-567-7240K
Key Blank	SPR-567-7320K
Draw Slide	SPR-567-7000K
Lid Stays	SPR-567-6950K
Draw Liner	SPR-567-6610K

For Prices see Page 583

Colour	Width (mm)	Depth (mm)	Height (mm)	Weight each	Order Code KEN-594	Price/1 TB
Red	690	315	385	44.0kg	-5200K	10397.00

Extra Deep Tool Chests

5 Drawer

Over 25% deeper than standard size tool chests for extra storage.

Drawer sizes (W x D x H):

3@ 595 x 405 x 50mm.
2@ 595 x 405 x 100mm.

Uses 14" drawer slides.
Type B lid stays.



EXTRA DEEP

Spares	Order Code
Lock	SPR-567-7240K
Key Blank	SPR-567-7320K
Draw Slide	SPR-567-7060K
Lid Stays	SPR-567-6960K
Draw Liner	SPR-567-6610K

For Prices see Page 583

Colour	Width (mm)	Depth (mm)	Height (mm)	Weight each	Order Code KEN-594	Price/1 TB
Red	660	405	510		-5340K	20652.00

6 Drawer

Top compartment size:

660 x 150 x 90mm.

Drawer sizes (W x D x H):

2@ 125 x 285 x 50mm.
1@ 280 x 285 x 50mm.
2@ 590 x 285 x 50mm.
1@ 590 x 285 x 100mm.



Spares	Order Code
Lock	SPR-567-7240K
Key Blank	SPR-567-7320K
Draw Slide	SPR-567-7060K
Lid Stays	SPR-567-6960K
Draw Liner	SPR-567-6610K

For Prices see Page 583

Colour	Width (mm)	Depth (mm)	Height (mm)	Weight each	Order Code KEN-594	Price/1 TB
Red	690	315	385	44.0kg	-5240K	11845.00

9 Drawer

Over 25% deeper than standard size tool chests for extra storage.

Drawer sizes (W x D x H):

6@ 295 x 405 x 50mm.
2@ 595 x 405 x 50mm.
1@ 595 x 405 x 100mm.

Uses 14" drawer slides.
Type B lid stays.



EXTRA DEEP

Spares	Order Code
Lock	SPR-567-7240K
Key Blank	SPR-567-7320K
Draw Slide	SPR-567-7060K
Lid Stays	SPR-567-6960K
Draw Liner	SPR-567-6610K

For Prices see Page 583

Colour	Width (mm)	Depth (mm)	Height (mm)	Weight each	Order Code KEN-594	Price/1 TB
Red	660	405	510		-5360K	23175.00

HAND TOOLS

PRODUCTS ARE ONLY AVAILABLE VIA YOUR DISTRIBUTOR

GROUP 594 ROLLER CABINETS & TOOL CHESTS

KENNEDY PROFESSIONAL Extra Deep, Heavy Duty Tool Chest

4 Drawer + Top Compartment

Heavy gauge steel, welded and riveted to form an extremely rigid construction. The two part epoxy powder paint finish gives excellent corrosion-resistance and ensures durability. Central locking system. A full width piano hinge provides rigidity, strength and additional security. The drawers have smooth running ball bearing slides and each has its own safety catch. The four full-length drawers have rigid aluminium edged handles and are sized:

Drawer sizes (W x D x H):

2@ 560 x 340 x 40mm. 1@ 560 x 340 x 65mm.
1@ 560 x 340 x 95mm.



Spares

Lock	SPR-567-7240K
Key Blank	SPR-567-7320K
Draw Slides	SPR-567-7060K
Lid Stays	SPR-567-4820K
Draw Liner	SPR-567-6610K
Lock Link	SPR-567-7410K

For Prices see Page 583

Lock Links to suit Extra Heavy-Duty Chests & Cabinets

To suit Cabinet/Chest (Order Code)	Order Code	Price/1 TB
KEN-594-4820K	SPR-567	-7400K 319.00
KEN-594-4860K		

Extra Deep, Extra Large, Heavy-Duty Tool Chest

9 Drawer + Top Compartment

Heavy gauge steel, welded and riveted to form this extra large chest. Corrosion resistant powder coated finish provides superb durability. Locking mechanism locks all drawers as the lid is closed and each drawer has its own safety catch. Four heavy-duty type carry handles with comfortable grips for easier lifting. The lid has a full width piano hinge giving extra rigidity, strength and additional security. Drawers have smooth running ball bearing drawer slides and rigid aluminium edged handles.

Drawer sizes (W x D x H):

2@ 560 x 340 x 40mm. 2@ 305 x 340 x 40mm.
2@ 560 x 340 x 65mm. 1@ 305 x 340 x 65mm.
1@ 560 x 340 x 95mm. 1@ 305 x 340 x 180mm.



Width (mm)	Depth (mm)	Height (mm)	Weight each	Order Code KEN-594	Price/1 TB
700	405	450	35.5kg	-4820K	18025.00

Width (mm)	Depth (mm)	Height (mm)	Weight each	Order Code KEN-594	Price/1 TB
1050	405	530	68kg	-4860K	36050.00

Features of our XD & XDXL Range



HD Castors HD Side Handle Checker-plate Top Gas Strut HD Chest Handles Individual Catches Ball Bearing Slides

Extra Deep, Heavy-Duty Roller Cabinet

7 Drawer

Heavy gauge steel, welded and riveted to give an extremely rigid construction. Corrosion resistant powder coated finish. Locking mechanism locks all the closed drawers which have individual safety catches to prevent accidental opening. Four heavy-duty castors, two fixed and two swivel which when combined with the heavy-duty side handle enable the user to move it with ease. All drawers have smooth running ball bearing drawer slides and aluminium edged handles.

Drawer sizes (W x D x H):

1@ 570 x 393 x 52mm.
4@ 570 x 393 x 80mm.
1@ 570 x 393 x 108mm.
1@ 570 x 393 x 154mm.



Lock Links to suit Extra Heavy-Duty Chests & Cabinets

To suit Cabinet/Chest (Order Code)	Order Code	Price/1 TB
KEN-594-4840K	SPR-567	-7410K 425.00

Width (mm)	Depth (mm)	Height (mm)	Weight each	Order Code KEN-594	Price/1 TB
690	460	995	71.5kg	-4840K	33931.00

Extra Deep, Extra Large, Heavy-Duty Roller Cabinet

13 Drawer

Heavy gauge steel, welded and riveted to give extremely rigid construction. The two-part epoxy powder paint finish gives excellent corrosion resistance and ensures durability. Central locking system. Heavy-duty castors and side handle designed to cope with the extra large size and weight. Drawers have smooth running ball bearing drawer slides and rigid aluminium edged handles.

Drawer sizes (W x D x H):

2@ 560 x 390 x 95mm. 1@ 305 x 390 x 95mm.
4@ 560 x 390 x 65mm. 3@ 305 x 390 x 65mm.
1@ 560 x 390 x 205mm. 1@ 305 x 390 x 180mm.
1@ 305 x 390 x 205mm.



Lock Links to suit Extra Heavy-Duty Chests & Cabinets

To suit Cabinet/Chest (Order Code)	Order Code	Price/1 TB
KEN-594-4880K	SPR-567	-7410K 425.00

Width (mm)	Depth (mm)	Height (mm)	Weight each	Order Code KEN-594	Price/1 TB
1065	460	1052	119.5kg	-4880K	52530.00

HAND TOOLS

KENNEDY PROFESSIONAL Extra Large Tool Chests & Roller Cabinets

Manufactured from heavy gauge steel with double wall construction side panels and welded joints for added rigidity. Coated in a hard wearing epoxy powder. Fully opening drawers for extra accessibility. Quick release smooth running ball bearing drawer slides. Supplied with top mat and drawer liners. Fully locking. 125 x 50mm heavy duty extra strong castors, fitted with two brakes. Castors are rated to 100kg capacity standing load per castor. Drawer loads should be evenly distributed. Roller cabinets are not suitable for frequent relocation when loaded and should only ever be pushed.

11 Drawer Top Chest

Top compartment (W x D x H): 1020 x 390 x 100mm.

Drawer sizes (W x D x H):

5@ 580 x 415 x 50mm. 1@ 580 x 415 x 100mm.

4@ 270 x 415 x 50mm. 1@ 270 x 415 x 150mm.



Spares	Order Code
Lock	SPR-567-7240K
Key Blank	SPR-567-7320K
Draw Slide	SPR-567-7040K
Lid Stays	SPR-567-6970K
Top Mat	SPR-567-6780K
Draw Liner	SPR-567-6610K

For Prices see Page 583

EXTRA LARGE

11 Drawer Roller Cabinet

Drawer sizes (W x D x H):

4@ 270 x 415 x 50mm.

4@ 560 x 415 x 50mm.

2@ 560 x 415 x 100mm.

1@ 560 x 415 x 170mm.

Uses 14" drawer slides.

Type B lid stays.

For Spares see Page 583



Spares	Order Code
Lock	SPR-567-7210K
Key Blank	SPR-567-7320K
Draw Slide	SPR-567-7040K
Castor's	SPR-567-6920K
Top Mat	SPR-567-7540K
Draw Liner	SPR-567-6610K

For Prices see Page 583

EXTRA LARGE

Colour	Width (mm)	Depth (mm)	Height (mm)	Weight each	Order Code KEN-594	Price/1 TB
Red	1030	460	530	94.0kg	-5780K	27295.00

Colour	Width (mm)	Depth (mm)	Height (mm)	Weight each	Order Code KEN-594	Price/1 TB
Red	680	480	1130	83.0kg	-5740K	44855.00

7 Drawer Roller Cabinet

Internal drawer dimensions

Bottom compartment (W x D x H):

400 x 460 x 300mm.

400 x 460 x 415mm

Drawer sizes (W x D x H):

4@ 580 x 415 x 50mm. 2@ 580 x 415 x 100mm. 1@ 580 x 415 x 150mm.

Uses 14" drawer slides.

Type B lid stays.

EXTRA LARGE



Spares	Order Code
Lock	SPR-567-7260K
Key Blank	SPR-567-7320K
Draw Slide	SPR-567-7040K
Castor's	SPR-567-6920K
Top Mat	SPR-567-7520K
Draw Liner	SPR-567-6610K

For Prices see Page 583

Colour	Width (mm)	Depth (mm)	Height (mm)	Weight each	Order Code KEN-594	Price/1 TB
Red	1060	480	925	81.0kg	-5700K	42615.00

Magnetic Tool Tray

Steel tool/parts tray with durable hardwearing corrosion-resistant powder coated finish. Suitable for keeping small parts, components and tools near to hand when working on vehicles, domestic appliances and other equipment. Three high strength magnets in protective non-scratch rubber coating.



Length x Width x Depth (mm)	Weight each	Order Code KEN-594	Price/1 TB
210 x 115 x 115	739g	-6500K	823.00
310 x 115 x 115	939g	-6520K	926.00

HAND TOOLS

PRODUCTS ARE ONLY AVAILABLE VIA YOUR DISTRIBUTOR

GROUP 594 ROLLER CABINETS & TOOL CHESTS

YAMOTO Tool Chest



6 Drawer Tool Chest

Made from 0.8mm steel panels with 0.6mm drawers. Powder coated yellow/grey with aluminium drawer pulls. The fully locking lid encloses the six drawers which have foam liners and smooth running 250mm ball bearing drawer slides. Supplied with a loose tote tray for carrying tools to work area.

Overall dimensions (W x D x H):
668 x 315 x 389mm.

Top compartment (W x D x H):
660 x 305 x 50mm.

Tote tray (W x D x H):
430 x 170 x 45mm.

Drawer sizes (W x D x H):
@ 590 x 279 x 101.5mm.
2@ 590 x 279 x 49mm.
1@ 281 x 279 x 49mm.
2@ 127 x 279 x 49mm.

Spares	Order Code
Lock	SPR-567-7240K
Key Blank	SPR-567-7320K
Draw Slide	SPR-567-7020K
Lid Stays	SPR-567-6950K
Draw Liner	SPR-567-6610K

For Prices see Page 583

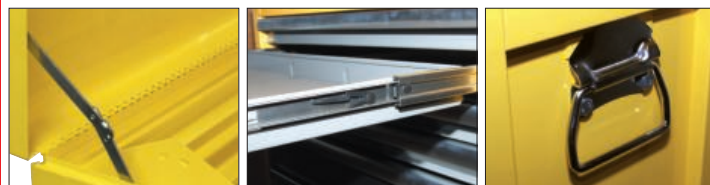
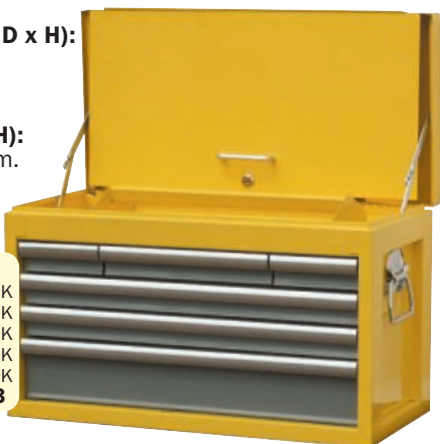

Colour	Width (mm)	Depth (mm)	Height (mm)	Weight each	Order Code YMT-594	Price/1 TB
Yellow	668	315	389	22.2kg	-5240K	12000.00

Roller Cabinet

7 Drawer Roller Cabinet

Body made from 1mm steel panels with 0.8mm drawers. Powder coated yellow/grey with aluminium drawer pulls. Fully opening drawers. Smooth running 350mm ball bearing drawer slides. Rubber top mat and foam drawer liners. Fully locking. 100 x 25mm heavy duty castors, with two brakes. Strong 450mm wide handle.

Overall dimensions (W x D x H):
689 (760 with handle) x 459 x 780mm (915 with castors).

Drawer sizes (W x D x H):
4@ 590 x 409 x 49mm.
2@ 590 x 409 x 101.5mm.
1@ 590 x 409 x 206.5mm.

Spares	Order Code
Lock	SPR-567-7210K
Key Blank	SPR-567-7320K
Draw Slide	SPR-567-7050K
Castors	SPR-567-6900K
Top Mat	SPR-567-7560K
Draw Liner	SPR-567-6610K

For Prices see Page 583



Colour	Width (mm)	Depth (mm)	Height (mm)	Weight each	Order Code YMT-594	Price/1 TB
Yellow	689	459	780	48.9kg	-5580K	29245.00

Tool Chests

Double thickness side walls. One piece drawer slides. Epoxy powder coated finish. Carry handles. All steel construction. Supplied with drawer liners. Piano hinge and lid stays. Supplied with tote tray.

Spares	Order Code
Lock	SPR-567-7240K
Key Blank	SPR-567-7320K
Draw Slide	SPR-567-7020K
Lid Stays	SPR-567-6950K
Draw Liner	SPR-567-6610K

For Prices see Page 583



3 Drawer Drawer sizes (W x D x H):

1@ 590 x 285 x 50mm.
2@ 590 x 285 x 100mm.

Top compartment size (W x D x H):
660 x 150 x 90mm.

Uses 10" Drawer slides.
Type A lid stays.



Colour	Width (mm)	Depth (mm)	Height (mm)	Weight each	Order Code YMT-594	Price/1 TB
Red	670	315	385	27kg	-0200K	10815.00

6 Drawer Drawer sizes (W x D x H):

2@ 130 x 285 x 50mm.
1@ 280 x 285 x 50mm.
2@ 590 x 285 x 50mm.
1@ 590 x 285 x 100mm.

Top compartment size (W x D x H):
660 x 150 x 90mm.

Uses 10" drawer slides.
Type A lid stays.



Colour	Width (mm)	Depth (mm)	Height (mm)	Weight each	Order Code YMT-594	Price/1 TB
Red	670	315	385	27kg	-0240K	14312.00

12 Drawer Drawer sizes (W x D x H):

8@ 130 x 410 x 50mm.
1@ 280 x 410 x 100mm.
2@ 590 x 410 x 50mm.
1@ 590 x 410 x 100mm.

Top compartment size (W x D x H):
660 x 150 x 90mm.

Uses 10" drawer slides.
Type A lid stays.



Colour	Width (mm)	Depth (mm)	Height (mm)	Weight each	Order Code YMT-594	Price/1 TB
Red	670	445	490	47kg	-0280K	24267.00

HAND TOOLS

YAMOTO *Roller Cabinets*

Double wall side panels and welded joints for added rigidity. Solid one piece I-beam drawer slides with double sliders on base drawer. Supplied with top mat and drawer liners. Fully locking. 100mm rubber castors, two brakes. Drawer loads should be evenly distributed. Roller cabinets are not suitable for frequent relocation when loaded, and should only ever be pushed.

Spares	Order Code
Lock	SPR-567-7210K
Key Blank	SPR-567-7320K
Draw Slide	SPR-567-7050K
Castors	SPR-567-6900K
Top Mat	SPR-567-7560K
Draw Liner	SPR-567-6610K

For Prices see Page 583



3 Drawer
Overall dimensions (W x D x H):
 690 x 460 x 850mm.
Bottom compartment (W x D x H):
 610 x 430 x 355mm.
Drawer sizes (W x D x H):
 3@ 590 x 410 x 100mm.
 Uses 16" drawer slides.



Colour	Weight each	Order Code	Price/1 TB
Red	43.0kg	YMT-594 -0500K	13814.00

5 Drawer
Overall dimensions (W x D x H):
 690 x 460 x 850mm.
Internal drawer dimensions (W x D x H):
 4@ 590 x 410 x 100mm.
 1@ 590 x 410 x 200mm.
 Uses 16" drawer slides.



Colour	Weight each	Order Code	Price/1 TB
Red	46.5kg	YMT-594 -0540K	22713.00

7 Drawer
Overall dimensions (W x D x H):
 690 x 460 x 850mm.
Internal drawer dimensions (W x D x H):
 4@ 590 x 410 x 50mm.
 2@ 590 x 410 x 100mm.
 1@ 590 x 410 x 200mm.
 Uses 16" drawer slides.



Colour	Weight each	Order Code	Price/1 TB
Red	52.5 kg	YMT-594 -0580K	24267.00

4-Drawer Service Cart

Industrial all steel construction with a Hi-Vis yellow and grey spray paint finish. Full width piano hinge. Chrome oval handle for comfort. Double extending ball bearing drawer runners for full drawer depth opening and smooth operation. 4x 4" solid rubber castors with 360° rotation. Two rear castors feature lever locking mechanism to reduce unwanted movement. Large open base bay. Lid stays to hold the lid in a vertical position when in use. Protective drawer liners prevent scratching and reduce tool noise. Double locking system: Drawer lever locking mechanism within top tool bay. Key locking drop down lid for the top tool bay. Supplied flat packed for on-site assembly.



Overall dimensions (W x H x D):
 770 x 960 x 520mm.
2 drawers (W x H x D Internal):
 300 x 70 x 440mm.
2 drawers (W x H x D Internal):
 640 x 70 x 440mm.
Maximum capacities:
Drawers:
 40kg/drawer.
Overall: 280kg.
Top tool bay:
 675 x 450mm storage.
 2x 35 x 470mm tool storage.



Width (mm)	Depth (mm)	Height (mm)	Weight each	Order Code	Price/1 TB
855	500	960	53.0kg	YMT-594 -2040K	23583.00
Description				Order Code	Price/1 TB
Replacement 90° Lock Set				YMT-567 -6800K	479.00
Replacement Drawer Sliders (Pr)				-7100K	897.00

PRODUCTS ARE ONLY AVAILABLE VIA YOUR DISTRIBUTOR

HAND TOOLS

GROUP 594 ROLLER CABINETS & TOOL CHESTS

SENATOR *Tool Chest*
QUALITY TOOLING

6 Drawer

Body made from 0.8mm steel panels with 0.6mm drawers. Powder coated finish in blue/grey with aluminium drawer pulls. The fully locking fold down lid encloses the six drawers which have foam liners and smooth running 250mm ball bearing drawer slides. Supplied with a loose tote tray. Chrome carrying handles.



Ball Bearing Drawer Slides

Overall dimensions

(W x D x H): 668 x 315 x 389mm.

Top compartment

(W x D x H): 660 x 305 x 50mm.

Tote tray (W x D x H):

430 x 170 x 45mm.

Drawer sizes

(W x D x H):
1@ 590 x 279 x 101.5mm,
2@ 590 x 279 x 49mm,
1@ 81 x 279 x 49mm,
2@ 127 x 279 x 49mm.



Colour	Width (mm)	Depth (mm)	Height (mm)	Weight each	Order Code SEN-594	Price/1 TB
Blue	668	315	389	22.9kg	-5240K	11369.00

Roller Cabinet

7 Drawer

Body made from 1mm steel panels with 0.8mm drawers. Powder coated finish in blue/grey with aluminium drawer pulls. Fully opening drawers for extra accessibility. Quick release smooth running 350mm ball bearing drawer slides. Rubber top mat and foam drawer liners. Fully locking. 100 x 25mm heavy duty castors, fitted with two brakes. Strong 450mm wide handle. Drawer loads should be evenly distributed. Roller cabinets should only be pushed.

Overall dimensions (W x D x H):

689 - 760 with handle x 459 x 780mm - 915 with castors.

Drawer sizes (W x D x H): 4@ 590 x 409 x 49mm, 2@ 590 x 409 x 101.5mm, 1@ 590 x 409 x 206.5mm.



Ball Bearing Drawer Slides

Spares	Order Code
Lock	SPR-567-7180K
Key Blank	SPR-567-7340K
Draw Slides 10"	SPR-567-7080K
Draw Slides 14"	SPR-567-7100K
Castors	SPR-567-6930K
Lid Stays	SPR-567-6980K
Draw Liner	SPR-567-6610K

For Prices see Page 583

Colour	Width (mm)	Depth (mm)	Height (mm)	Weight each	Order Code SEN-594	Price/1 TB
Blue	689	459	780	48.9kg	-5580K	22145.00

Tool Chests

For the cost conscious, DIY and light industrial use.

3 Drawer

Piano hinged lid. Carry handle. Cantilever top tray. Fully locking.

Drawer sizes (W x D x H):

3@ 450 x 190 x 55mm. Uses 10" drawer slides. Type A lid stays.



Spares	Order Code
Lock	SPR-567-7200K
Key Blank	SPR-567-7300K
Draw Slide	SPR-567-7020K
Draw Liner	SPR-567-6610K

For Prices see Page 583

Colour	Width (mm)	Depth (mm)	Height (mm)	Weight each	Order Code SEN-594	Price/1 TB
Red	520	218	304	9.1kg	-0200K	3864.00

6 Drawer

Piano hinge. Carry handles. Tote tray. Fully locking. Two wall construction side panels. I-Beam draw slides.

Drawer sizes (W x D x H):

2@ 50 x 125 x 280mm.
1@ 50 x 280 x 280mm.
2@ 50 x 590 x 280mm.
1@ 100 x 590 x 280mm.

Spares	Order Code
Lock	SPR567-7240K
Key Blank	SPR567-7320K
Draw Slide	SPR567-7020K
Lid Stay	SPR567-6950K
Draw Liner	SPR567-6610K

For Prices see Page 583

Uses 10" drawer slides. Type A lid stays.



Colour	Width (mm)	Depth (mm)	Height (mm)	Weight each	Order Code SEN-594	Price/1 TB
Red	670	320	390	26kg	-0240K	11829.00

3 Tray Tool Trolley

Bolted steel construction. 100mm industrial castors. Brakes fitted to two end castors. Hard wearing powder coated finish.



Overall Length	Overall Width	Overall Depth	Weight each	Order Code SEN-594	Price/1 TB
737mm	383mm	663mm	3.70kg	-4030K	6167.00

HAND TOOLS

SENATOR QUALITY TOOLING *Roller Cabinets*

Double thickness side walls with welded joints and a hard wearing epoxy powder coating. I-Beam draw slides with double sliders on base drawer. 100mm rubber castors with brakes fitted to two end castors. Fully locking. Castors are rated to 40kg capacity standing load per castor. Drawer loads should be evenly distributed. Roller cabinets are not suitable for frequent relocation when loaded and should only ever be pushed.

Spares	Order Code
Lock	SPR-567-7210K
Key Blank	SPR-567-7320K
Draw Slide	SPR-567-7050K
Castors	SPR-567-6900K
Top Mat	SPR-567-7560K
Draw Liner	SPR-567-6610K



For Prices see Below

3 Drawer
Overall dimensions (W x D x H):
 680 x 435 x 660mm.
Drawer sizes (W x D x H):
 3@ 511 x 403 x 75mm.
Bottom compartment (W x D x H):
 678 x 425 x 368mm.
 Uses 16" drawer slides.



Colour	Weight each	Order Code SEN-594	Price/1 TB
Red	26kg	-1030K	11829.00

5 Drawer
Overall dimensions (W x D x H):
 680 x 435 x 660mm.
Drawer sizes (W x D x H):
 3@ 511 x 403 x 75mm.
 2@ 551 x 403 x 155mm.
 Uses 16" drawer slides.



Colour	Weight each	Order Code SEN-594	Price/1 TB
Red	33kg	-1050K	14940.00

7 Drawer
Overall dimensions (W x D x H):
 670 x 460 x 885mm.
Drawer sizes (W x D x H):
 4@ 590 x 410 x 50mm.
 2@ 590 x 410 x 100mm.
 1@ 590 x 410 x 200mm.
 Uses 16" drawer slides.



Colour	Weight each	Order Code SEN-594	Price/1 TB
Red	51kg	-0580K	23028.00

Cabinet & Chest Spares

* Note: Draw liner size is 583 x 405mm and can be cut to size. All spare keys are supplied as blanks and will need cutting to size.

Cabinet/Chest Order Code	Lock		Key Blank		Draw Slides		Lid Stays		Castors		Top Mat		Draw Liner*	
	Order Code SPR-567	Price/1 TB	Order Code SPR-567	Price/1 TB	Order Code SPR-567	Price/1 TB	Order Code SPR-567	Price/1 TB	Order Code SPR-567	Price/1 TB	Order Code SPR-567	Price/1 TB	Order Code SPR-567	Price/1 TB
KENNEDY														
KEN-594-1540K	-7210K	672.00	-7320K	78.00	-7040K	799.00	-	-	-	-	-	-	-6610K	67.00
KEN-594-4820K	-7240K	585.00	-7320K	78.00	-7060K	720.00	-4820K	773.00	-	-	-	-	-6610K	67.00
KEN-594-4840K	-7210K	672.00	-7320K	78.00	-7040K	799.00	-	-	-6910K	4635.00	-	-	-6610K	67.00
KEN-594-4860K	-7240K	585.00	-7320K	78.00	-7060K	720.00	-4860K	773.00	-	-	-	-	-6610K	67.00
KEN-594-4880K	-7210K	672.00	-7320K	78.00	-7040K	799.00	-	-	-6910K	4635.00	-	-	-6610K	67.00
KEN-594-5200K	-7240K	585.00	-7320K	78.00	-7000K	572.00	-6950K	186.00	-	-	-	-	-6610K	67.00
KEN-594-5210K	-7240K	585.00	-7320K	78.00	-7000K	572.00	-6950K	186.00	-	-	-	-	-6610K	67.00
KEN-594-5240K	-7240K	585.00	-7320K	78.00	-7000K	572.00	-6950K	186.00	-	-	-	-	-6610K	67.00
KEN-594-5250K	-7240K	585.00	-7320K	78.00	-7000K	572.00	-6950K	186.00	-	-	-	-	-6610K	67.00
KEN-594-5280K	-7240K	585.00	-7320K	78.00	-7040K	799.00	-6950K	186.00	-	-	-	-	-6610K	67.00
KEN-594-5290K	-7240K	585.00	-7320K	78.00	-7040K	799.00	-6950K	186.00	-	-	-	-	-6610K	67.00
KEN-594-5340K	-7240K	585.00	-7320K	78.00	-7060K	720.00	-6960K	186.00	-	-	-	-	-6610K	67.00
KEN-594-5360K	-7240K	585.00	-7320K	78.00	-7060K	720.00	-6960K	186.00	-	-	-	-	-6610K	67.00
KEN-594-5400K	-7210K	672.00	-7320K	78.00	-7040K	799.00	-	-	-	-	-7560K	1007.00	-6610K	67.00
KEN-594-5410K	-7210K	672.00	-7320K	78.00	-7040K	799.00	-	-	-	-	-7560K	1007.00	-6610K	67.00
KEN-594-5500K	-7260K	1288.00	-7320K	78.00	-7040K	799.00	-	-	-6920K	4893.00	-7560K	1007.00	-6610K	67.00
KEN-594-5510K	-7260K	1288.00	-7320K	78.00	-7040K	799.00	-	-	-6920K	4893.00	-7560K	1007.00	-6610K	67.00
KEN-594-5540K	-7210K	672.00	-7320K	78.00	-7040K	799.00	-	-	-6920K	4893.00	-7560K	1007.00	-6610K	67.00
KEN-594-5550K	-7210K	672.00	-7320K	78.00	-7040K	799.00	-	-	-6920K	4893.00	-7560K	1007.00	-6610K	67.00
KEN-594-5580K	-7210K	672.00	-7320K	78.00	-7040K	799.00	-	-	-6920K	4893.00	-7560K	1007.00	-6610K	67.00
KEN-594-5590K	-7210K	672.00	-7320K	78.00	-7040K	799.00	-	-	-6920K	4893.00	-7560K	1007.00	-6610K	67.00
KEN-594-5700K	-7260K	1288.00	-7320K	78.00	-7040K	799.00	-	-	-6920K	4893.00	-7520K	1007.00	-6610K	67.00
KEN-594-5740K	-7210K	672.00	-7320K	78.00	-7040K	799.00	-	-	-6920K	4893.00	-7540K	1007.00	-6610K	67.00
KEN-594-5780K	-7240K	585.00	-7320K	78.00	-7040K	799.00	-6970K	186.00	-	-	-6780K	160.00	-6610K	67.00
KEN-594-6020K	-7210K	672.00	-7320K	78.00	-7040K	799.00	-	-	-6910K	4635.00	-7540K	1007.00	-6610K	67.00
SENATOR QUALITY TOOLING														
SEN-594-0200K	-7200K	372.00	-7300K	107.00	-7020K	531.00	-	-	-	-	-	-	-6610K	67.00
SEN-594-0240K	-7240K	585.00	-7320K	78.00	-7020K	531.00	-6950K	186.00	-	-	-	-	-6610K	67.00
SEN-594-0580K	-7210K	672.00	-7320K	78.00	-7050K	372.00	-	-	-6900K	1700.00	-7560K	1007.00	-6610K	67.00
SEN-594-1030K	-7210K	672.00	-7320K	78.00	-7050K	372.00	-	-	-6900K	1700.00	-7560K	1007.00	-6610K	67.00
SEN-594-1050K	-7210K	672.00	-7320K	78.00	-7050K	372.00	-	-	-6900K	1700.00	-7560K	1007.00	-6610K	67.00
YAMOTO														
YMT-594-0200K	-7240K	585.00	-7320K	78.00	-7020K	531.00	-6950K	186.00	-	-	-	-	-6610K	67.00
YMT-594-0240K	-7240K	585.00	-7320K	78.00	-7020K	531.00	-6950K	186.00	-	-	-	-	-6610K	67.00
YMT-594-0280K	-7240K	585.00	-7320K	78.00	-7020K	531.00	-6950K	186.00	-	-	-	-	-6610K	67.00
YMT-594-0500K	-7210K	672.00	-7320K	78.00	-7050K	372.00	-	-	-6900K	1700.00	-7560K	1007.00	-6610K	67.00
YMT-594-0540K	-7210K	672.00	-7320K	78.00	-7050K	372.00	-	-	-6900K	1700.00	-7560K	1007.00	-6610K	67.00
YMT-594-0580K	-7210K	672.00	-7320K	78.00	-7050K	372.00	-	-	-6900K	1700.00	-7560K	1007.00	-6610K	67.00
YMT-594-5240K	-7180K	478.00	-7340K	107.00	-7080K	531.00	-6980K	514.00	-	-	-	-	-6610K	67.00
YMT-594-5580K	-7180K	478.00	-7340K	107.00	-7100K	691.00	-	-	-6930K	2918.00	-7560K	1007.00	-6610K	67.00

PRODUCTS ARE ONLY AVAILABLE VIA YOUR DISTRIBUTOR

HAND TOOLS

GROUP 595 TOOL CONTROL

KENNEDY PROFESSIONAL Tool Control

CAD designed and high precision laser cut foam tray inserts are designed to keep tools precisely and accurately in the correct position and drawers for improved productivity. In some applications a dropped tool is a serious hazard, colour contrasting foam inserts are used to easily recognise lost tooling and also reduce audit time. Areas of use include food industry maintenance, automotive assembly.



25 Piece Set - TCD025

Professional Pliers

- 1x 160mm snipe nose.
- 1x 160mm diagonal cutters.
- 1x 160mm combination.

Pro-Torq Screwdrivers

Crosspoint:

- No.2 x stubby, No.2 x 100mm.

Pozidriv:

- No.1 x 75,
- No.2 x 100,
- No.3 x 150mm.

Flared:

- 6.3 x 150, 8.0 x 200mm.

Parallel:

- 5.0 x 150mm.

Metric Professional Combination Wrenches

- 6, 7, 8, 9, 10, 11, 12, 13, 14, 15, 16, 17, 18 and 19mm.



**25
PIECES**

Product Number	Number of Pieces	Weight each	Order Code KEN-595	Price/1 TB
TCD025	25	2.3kg	-5000K	9388.00

Dimensions: 590 x 410 x 45mm

Suitable for Kennedy Toolchests - KEN-594-5580K
(see page 576 for details)

50 Piece Set - TCD050

3/8" Sockets: 6, 7, 8, 9, 10, 11, 12, 13, 14, 15, 16, 17, 18, 19, 20, 21 and 22mm.

Deep Sockets:

- 10, 11, 12, 13, 14, 15, 17, 19 and 22mm.

Screwdriver Bits:

Slotted

- 5, 5.5 and 6.5mm.

Crosspoint

- No.1, 2, 3, and 4.

Hex Bits:

- 3, 4, 5, 6, 8 and 10mm.

Accessories:

- Ratchet handle, sliding T-handle, spinner handle, swivel handle. Universal joint. 125 and 250mm extensions, 250mm wobble extensions, 1/4" and 1/2" male adaptors, 1/4" hex bit coupler.



**50
PIECES**

Product Number	Number of Pieces	Weight each	Order Code KEN-595	Price/1 TB
TCD050	50	6.2kg	-5020K	9388.00

HAND TOOLS



KENNEDY PROFESSIONAL Complete Tool Control Sets include Kennedy Professional Roller Cabinet

Manufactured from heavy gauge steel with double wall construction side panels and welded joints for added rigidity. Coated in a hard wearing epoxy powder. Fully opening drawers for extra accessibility. Quick release smooth running ball bearing drawer slides with double sliders on base drawer. Supplied with top mat and drawer liners. Fully locking. 125 x 50mm heavy-duty extra strong castors, fitted with two brakes.

Overall dimensions: 890 x 690 x 460mm. Castors are rated to 100kg capacity standing load per castor. Drawer loads should be evenly distributed.

Drawers (W x D x H): 4@ 590 x 410 x 50mm. 2@ 590 x 410 x 100mm. 1@ 590 x 410 x 200mm.

7 Drawer Roller Cabinet



25 Piece Set Configuration



50 Piece Set Configuration



25 Piece Set with Professional Roller Cabinet

TCC025

Professional Pliers

1x 160mm snipe nose,
1x 160mm diagonal cutters,
1x 160mm combination.

Metric Professional Combination Wrenches

6, 7, 8, 9, 10, 11, 12, 13,
14, 15, 16, 17, 18 and 19mm.

Pro-Torq Screwdrivers

Crosspoint: No.2 x stubby,
No.2 x 100mm.

Pozidriv(r): No.1 x 75, No.2 x 100,
No.3 x 150mm.

Flared: 6.3 x 150,
8.0 x 200mm.

Parallel: 5.0 x 150mm.

**25
PIECES**

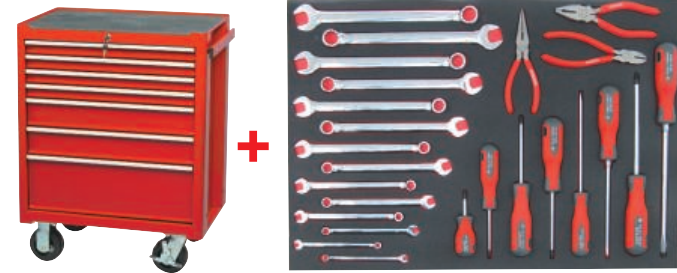

Product Number	Number of Pieces	Weight each	Order Code	Price/1 TB
TCC025	25	55.3kg	KEN-595	33763.00

50 Piece Set with Professional Roller Cabinet

TCC050

Sockets: 6, 7, 8, 9, 10, 11,
12, 13, 14, 15, 16, 17,
18, 19, 20, 21 and 22mm.

Deep Sockets: 10, 11, 12, 13,
14, 15, 17, 19 and 22mm.

Screwdriver Bits

Slotted: 5, 5.5 and 6.5mm.

Crosspoint: No.1, 2, 3, and 4.

Hex Bits: 3, 4, 5, 6, 8 and 10mm.

Accessories:

Ratchet handle, sliding T-handle, spinner handle, swivel handle. Universal joint. 125 and 250mm extensions, 250mm wobble extensions, 1/4" and 1/2" male adaptors, 1/4" hex bit coupler.

**50
PIECES**

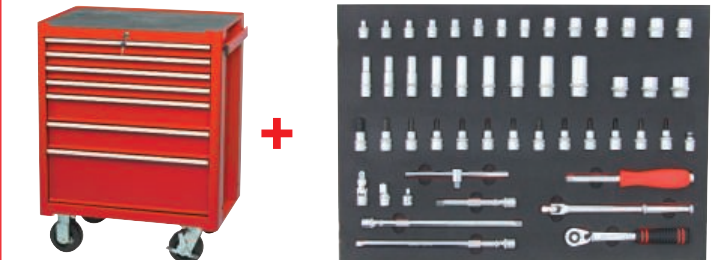

Product Number	Number of Pieces	Weight each	Order Code	Price/1 TB
TCC050	50	59.2kg	KEN-595	34629.00

75 Piece Set With Professional Roller Cabinet - TCC075

Professional Pliers

1x 160mm snipe nose,
1x 160mm diagonal cutters,
1x 160mm combination.

Pro-Torq Screwdrivers

Crosspoint: No.2 x stubby, No.2 x 100mm.

Pozidriv(r): No.1 x 75, No.2 x 100,
No.3 x 150mm.

Flared: 6.3 x 150, 8.0 x 200mm.

Parallel: 5.0 x 150mm.

Sockets: 6, 7, 8, 9, 10, 11, 12, 13,
14, 15, 16, 17, 18, 19, 20, 21
and 22mm.

Deep Sockets: 10, 11, 12, 13, 14,
15, 17, 19 and 22mm.

Screwdriver Bits

Slotted: 5, 5.5 and 6.5mm.

Crosspoint: No.1, 2, 3, and 4.

Hex Bits: 3, 4, 5, 6, 8 and 10mm.

Accessories:

Ratchet handle, sliding T-handle,
spinner handle, swivel handle.
Universal joint.

125 and 250mm extensions,
250mm wobble extensions,
1/4" and 1/2" male adaptors,
1/4" hex bit coupler.

**75
PIECES**



Product Number	Number of Pieces	Weight each	Order Code	Price/1 TB
TCC075	75	61.5kg	KEN-595	41013.00

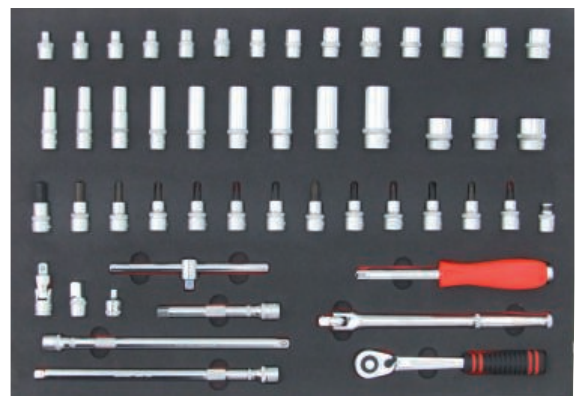

HAND TOOLS

GROUP 595 TOOL KITS

KENNEDY PROFESSIONAL 208 Piece Apprentice Engineer's Tool Kit- AET200

208 PIECES 

Supplied in a three drawer professional roller cabinet and a three drawer top chest. Manufactured from heavy gauge steel with double wall construction side panels and welded joints for added rigidity. Coated in a hard wearing epoxy powder. Fully opening drawers for extra accessibility. Quick release smooth running ball bearing drawer slides with double sliders on base drawer. Supplied with top mat and drawer liners. Fully locking. 125 x 50mm heavy duty extra strong castors, fitted with two brakes. Overall dimensions: 890 x 690 x 460mm. Castors are rated to 100kg capacity standing load per castor. Drawer loads should be evenly distributed.

3 Drawer Top Chest

Top compartment size: 89 x 661 x 150mm.

Drawer sizes: 1@ 51 x 591 x 282.5mm.

2@ 102 x 591 x 282.5mm.

3 Drawer Roller Cabinet

Internal drawer dimensions

Bottom compartment size: 610 x 432 x 356mm.

Drawer sizes: 3@ 591 x 410 x 102mm.

Contents:

- 25 piece HSS drill set 1 - 13.00mm x 0.5mm.
- Six piece 200mm double cut engineer's file set.
- Six piece 16cm cut 2 assorted needle file set.
- 25 x 230 x 280mm assorted abrasive sheet.
- 200mm chrome vanadium steel adjustable spanner.
- 6 x 150mm flat cold chisel.
- 19mm x 33m black pvc insulation tape.
- 76mm, 18 blade combination feeler gauge set.
- 4.8mm square head centre punch.
- 150mm/6" stainless steel rule c/w pocket clip.
- 178mm double ended Engineer's scriber.
- Eye loupe.
- Adjustable telescopic 30mm dia. inspection mirror (expands to 180mm).
- Six piece parallel pin punch set: 2.4, 3.2, 4.0, 4.8, 5.5 and 6.4mm.
- 150mm/6" engineer's square - **BS 939 grade B**.
- Tap wrenches 1.5 - 6.4mm and 6.4 - 19mm.
- Magnetic telescopic pick-up tool extends to 550mm.
- 29 piece engineer's bit set.
All 6mm hex x 25mm overall length, complete with magnetic spinner handle, 6mm hexagon bit adaptor and 6mm square socket adaptor.
Hexagon: 2, 3, 4, 5, 6, 7 and 8mm; flat 3, 4, 5, 5.5, 6.5 and 8mm; ³/₃₂", ¹/₈", ⁵/₃₂", ³/₁₆", ¹/₄", ⁷/₃₂" and ⁵/₁₆"; crosspoint No.1, 2 and 3; Pozidriv® No.1, 2 and 3.
- 450g (1lb) ball pein hammer wood shaft.
- 7.5m/25ft steel tape.
- Snap-off eight segment blade economy knife.
- Retractable trimming knife with five blades.
- Junior hacksaw frame.
- 300mm lightweight professional hacksaw frame.
- Six off 12" x 1/2" x 18tpi HSS hacksaw blades.
- 20 junior hacksaw blades.
- Two plastic handle household scissors.
- 150mm snipe nose plier with side cutter.
- 150mm diagonal cutting nipper.
- 150mm Engineer's combination pliers with side cutter.
- 250mm curved jaw high strength grip wrench.
- Eight piece Pro-Torq screwdriver set:
crosspoint No.1 x 75, No.2 x 100; pozidriv® No.2 x 100; flared 6.3 stubby, 6.3 x 100, 8.0 x 200; parallel 5.0 x 75, 5.0 x 150.
- 14 piece combination spanner set: 6, 7, 8, 9, 10, 11, 12, 13, 14, 15, 16, 17, 18 and 19mm.
- 25 piece metric socket set 1/2" square drive sockets: 8, 9, 10, 11, 12, 13, 14, 15, 16, 17, 18, 19, 22, 24, 27, 30 and 32mm.
Spark plug sockets: M10 and M14.
Accessories: quick release ratchet handle, sliding T-handle, universal joint, 75, 125 and 250mm extension bars.
- Nine piece metric hex key set 1.5 - 10mm.



Set contents may vary slightly according to product development and availability.

HAND TOOLS

Number of Pieces	Weight each	Order Code	Price/1 TB
208		KEN-595 -0550K	60167.00



**300
PIECES**

KENNEDY PROFESSIONAL 300 Piece Engineer's Professional Tool Kit

Supplied in a five drawer professional roller cabinet and a three drawer top chest. Manufactured from heavy gauge steel with double wall construction side panels and welded joints for added rigidity. Coated in a hard wearing epoxy powder. Fully opening drawers for extra accessibility. Quick release smooth running ball bearing drawer slides with double sliders on base drawer. Supplied with top mat and drawer liners. Fully locking. 125 x 50mm heavy duty extra strong castors, fitted with two brakes.

Overall dimensions: 890 x 690 x 460mm. Castors are rated to 100kg capacity standing load per castor. Drawer loads should be evenly distributed.

3 Drawer Top Chest

Top compartment size: 89 x 661 x 150mm.

Drawer sizes: 1@ 51 x 591 x 282.5mm,
2@ 102 x 591 x 282.5mm.

5 Drawer Roller Cabinet

Internal drawer dimensions:

4@ 591 x 460 x 102mm.

1@ 591 x 410 x 204mm.

Contents:

- Set of 25 HSS drills 1 - 13.00mm x 0.5mm.
- Eight piece 200mm (8") double cut Engineer's file set.
- Six piece 16cm cut 2 assorted needle file set.
- 20x 150mm (6") junior hacksaw blades.
- 10x 12" x 1/2" x 18TPI HSS all hard hacksaw blade.
- 25x 230mm x 280mm assorted abrasive sheets.
- 200mm (8") soft grip phosphate adjustable wrench.
- 6mm 150mm flat cold chisel.
- 3" 18-bade metric/inch comb feeler gauge set.
- 4" x 3/16" (4.8mm) square head centre punch.
- Set of 6 parallel pin punches.
- 150mm/6" inch/metric rigid rustless rule.
- 300mm/12" rigid rustless rule - round end.
- 150mm (6") Engineer's square.
- 300mm (12") Engineer's square.
- 7" double ended engineers scriber.
- 1 1/4" focal length eye loupe.
- Adjustable telescopic 1 1/4" mirror.
- Set of two: 1/16" - 1/4" and 1/4" - 3/4" tap wrenches.
- 1lb ball pein hammer - wood shaft.
- 16oz black rubber mallet - wood shaft.
- 5 1/2" plastic handle household scissors.
- 8 1/2" plastic handle household scissors.
- 5m/16" professional ABS steel tape.
- Snap-off 8 seg-blade heavy duty knife.
- Snap-off 13 seg-blade mini knife.
- Retractable trimming knife c/w five blades.
- Beaver style junior hacksaw.
- Professional 'plus' cushion grip hacksaw.
- Magnetic pick-up tool.
- Set of four Pro-Torq pliers.
- 10" curved jaw grip wrench.
- 12 piece Pro-Torq screwdriver set.
- 64 piece 1/4" hexagon bit set.
- 1/4" hex bit driver.
- Seven piece box spanner set 6 - 19mm c/w tommy bars.
- Combination wrenches: 10 - 19mm.
- 50 piece metric 3/8" square drive socket set.
- 8" straight blade tinsnip.
- Three drawer professional tool chest.
- Metal tote tray.
- Five drawer professional roller cabinet.
- Eight piece metric Pro-Torq hex wrench set on clip.
- Nine piece inch Pro-Torq hex wrench set on clip.
- 19mm x 33m black PVC insulation tape.



HAND TOOLS

Set contents may vary slightly according to product development and availability.

Number of Pieces	Weight each	Order Code	Price/1 TB
300		KEN-595 -3080K	71610.00

PRODUCTS ARE ONLY AVAILABLE VIA YOUR DISTRIBUTOR

GROUP 595 TOOL KITS

YAMOTO 100 Piece Mechanic's Starter Tool Kit

Contents:

- 8" and 12" satin chrome adjustable wrench set.
- 5m/16ft locking tape rule.
- Lightweight hacksaw frame.
- 400cc lever type steel grease gun.
- 150mm long nose pliers.
- 200mm long nose pliers.
- 150mm diagonal nippers.
- 150mm linesman's combination pliers.
- 200mm linesman's combination pliers.
- 250mm waterproof pliers.
- 12 piece mechanic's pattern screwdriver set.
- Seven piece 6 - 19mm chrome vanadium open ended spanner set.
- 14 piece 6 - 19mm chrome vanadium combination spanner set.
- 55 piece 3/8" drive socket and bit set.
- Six drawer red tool chest.

**100
PIECES**



Set contents may vary slightly according to product development and availability.

Number of Pieces	Weight each	Order Code	Price/1 TB
100	34.0kg	YMT-595 -3500K	28789.00

Mechanic's Tool Kit

52 Piece Mobile Mechanic's Tool Kit

Specifically designed for mechanics on the move.

Contents include: 582 x 298 x 255mm metal toolbox with tote tray, adjustable wrenches, pocket knife, pliers, screwdrivers, spanners and sockets.



NEW

**52
PIECES**



Number of Pieces	Weight each	Order Code	Price/1 TB
52		YMT-595 -2600K	9116.00

HAND TOOLS

SENATOR QUALITY TOOLING 90 Piece Engineer's Workshop Tool Kit

- Top chest.
- 24 piece 1/2" drive metric socket set.
- Six piece 16cm cut 2 assorted needle file set.
- 10x 12" x 1/2" x 18tpi all hard hacksaw blades.
- 8"/200mm chrome vanadium adjustable spanner.
- 12" rule - walleded.
- Metric/inch feeler gauge 60mm blade length.
- 1 1/2lb ball pein hammer- hickory shaft.
- 16oz black rubber mallet - wood shaft.
- 5m/16ft locking tape rule - chromed case.
- Eight segment 18mm heavy duty snap-off blade knife.
- Retractable trimming knife.
- DIY hacksaw.
- 2x 50mm G-clamps.
- 2x 100mm G-clamps.
- 6" snipe nose plier/side cutter.
- 8" straight blade tinsnip.
- 6" diagonal cutting nipper.
- 7" linesman plier.
- 10" multiple slip joint plier.
- 10" straight jaw high strength grip wrench.
- 16 function 10-blade tool.
- 15 piece duel grip screwdriver set.
- 14 piece 6 - 19mm drop forged combination spanner set.

**90
PIECES**

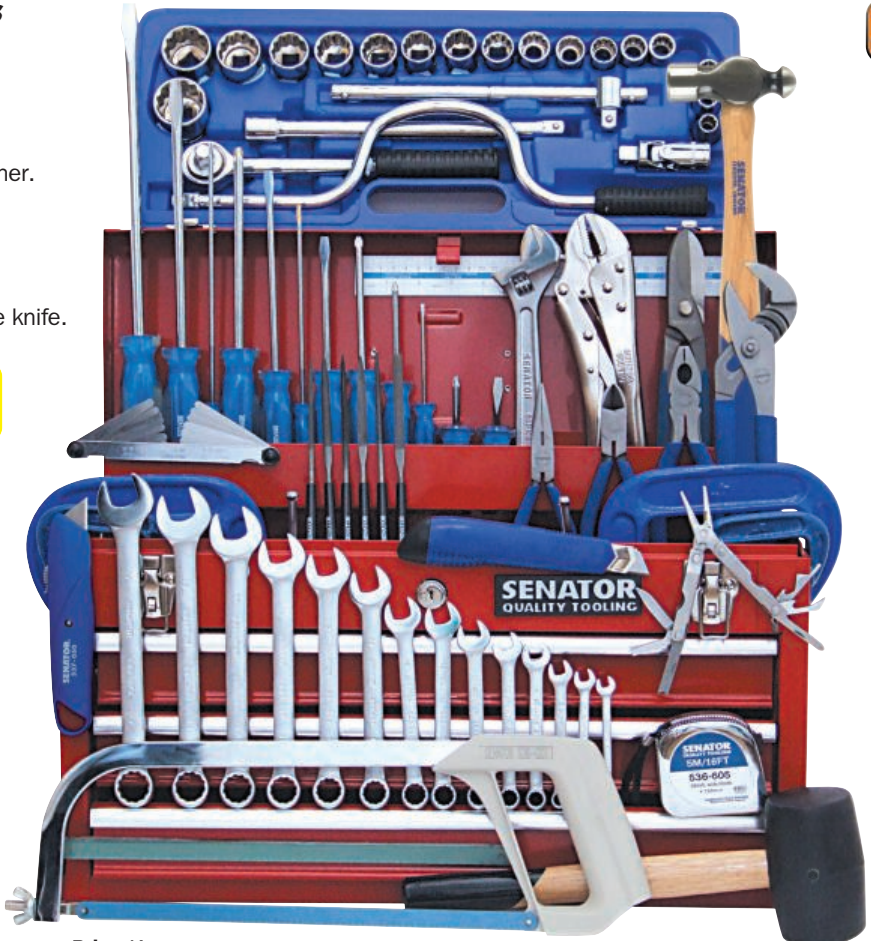

Set contents may vary slightly according to product development and availability.

Number of Pieces	Weight each	Order Code	Price/1 TB
90		SEN-595 -1000K	14575.00

KENNEDY PROFESSIONAL 62 Piece Workshop Tool Kit

5 compartment cantilever tool box with specially moulded trays to facilitate enhanced Tool Control and padlock hole for additional security.

- Sockets: 8 - 32mm, M10 and M14 spark plug
- 250mm Sliding T' Handle
- 125mm & 250mm extensions, 75mm wobble extension
- Quick release 72T rubber hatchet handle
- 375mm/15" jointed knurl gripped swivel handle
- Universal joint
- Combination Spanners: 6 -22mm
- Pro-torq screwdrivers: 5.5x100mm, 6.5x150mm and 8x200mm flat, No 0, No 2 and No 3 cross point.
- Pro-torq pliers: 180mm/7" combination, 150mm/6" snipe nose and 165mm/6" diagonal.
- Metric L-wrench ball driver set - 1.5 - 10mm

**62
PIECES**



Number of Pieces	Weight each	Order Code	Price/1 TB
62		KEN-595 -0050K	13905.00

56 Piece Standard Service Tool Kit

Suitable for use by service engineers, electricians and tradesmen. All Kennedy industrial quality tools carry a quality guarantee.

Contents:

- 430 x 340 x 160mm ABS plastic, aluminium reinforced, tool case.
- 150mm chrome adjustable wrench.
- 19mm x 33m black PVC insulation tape.
- 150mm mains tester range 125/250V.
- Soldering iron 25W/240V.
- Desoldering gun.
- 17g 1.0mm diameter 60/40 cored solder.
- 115mm sharp nose precision tweezers.
- 30mm diameter inspection mirror (handle extends up to 480mm).
- 7.5m/25ft steel tape.
- 13 segment-blade mini autolock retract knife.
- Junior hacksaw frame and blade.
- Magnetic pick up tool (extends to 550mm).
- 160mm snipe nose plier.
- 160mm diagonal cutting nipper.
- 160mm engineer's combination plier with side cutter.
- 150mm insulation and wire stripping plier.
- 115mm precision nippers.
- 115mm precision end cutting nippers.
- Chrome vanadium blade screwdrivers: crosspoint No.0, 1 and 2pt; slotted 6mm; supadriv No.0, 1 and 2pt.
- Offset screwdrivers: 5mm slot x No.1pt, 6mm slot x No.2pt.
- Insulated screwdrivers: parallel 4 x 100mm 1000V VDU, slotted 2.5 x 85mm.
- 20mm sash tool.
- 11 piece screwdriver and tool set: parallel 1, 1.2, 1.4, 1.8, 2.4 and 3mm; crosspoint PH0-2, PH0 and PH1; fine point awl and tweezers.
- 9 piece hex key set 1.5 - 10mm.
- Chrome vanadium combination spanners: 5.5, 6, 7, 8, 9 and 10mm.

**56
PIECES**

Set contents may vary slightly according to product development and availability.

Number of Pieces	Weight each	Order Code	Price/1 TB
56	6.8kg	KEN-595 -3000K	18071.00



HAND TOOLS

GROUP 595 TOOL KITS

KENNEDY PROFESSIONAL 122 Piece 'Deluxe' Service Engineer's Tool Kit



This superb kit contains all the necessary tools for the service engineer in a sturdy aluminium case partitioned to keep tools organised and readily accessible.

Contents

- Aluminium tool case.
- Six piece 16cm needle file set.
- 150mm adjustable wrench.
- Digital multimeter.
- 125/250V mains tester.
- 19mm x 33m insulation tape: black, red and green/yellow PVC.
- 25W soldering iron.
- Cable stripping knife.
- Desoldering gun.
- 60/40 cored solder.
- Butane soldering torch.
- Centre punch 2.4 x 3.2mm.
- 2x parallel pin punches.
- 150mm/6" flexible rustless rule.
- Machinist's scriber.
- Sharp nose tweezers.
- Flat blade tweezers.
- Eye loupe.
- Telescopic inspection mirror.
- Magnetic pick up tool (extends to 550mm).
- 225g (1/2lb) ball pein hammer.
- 3 1/2 oz cross pein hammer.
- 7.5m/25ft steel tape.
- Aluminium pocket torch.
- Retractable knife.
- Auto return utility knife.
- Junior hacksaw and blade.
- 10 junior hacksaw blades.
- 150mm flat nose plier.
- 150mm insulation and wire stripping plier.
- 150mm wire crimper/stripper.
- 160mm snipe nose plier.
- 160mm diagonal cutting nipper.
- 160mm combination plier.
- 4 piece circlip plier set.
- 177mm locking plier.
- 115mm precision flat nose plier.
- 115mm precision long nose plier.
- 115mm precision nippers.
- 115mm precision end cutting plier.
- 165mm soft touch pliers.
- Pro-Torq grip screwdrivers with chrome vanadium blade: slotted 100 x 6mm; crosspoint 76mm x No.0 and No.1, 6mm x No.2; supadriv 76mm x No.0 and 1, 4" x No.2; electrician's parallel 150 and 200 x 5mm.
- Offset screwdrivers: 5mm x No.1, 6mm x No. 2.
- Insulated screwdrivers: parallel 4 x 100mm, 1000V VDU, slotted 5.5 x 125mm.
- Torx screwdrivers: T6, T8 and T10.
- 11 piece screwdriver and tool set.
- Nine piece 5.5 - 13mm combination spanner set.
- Seven piece electronic screwdriver set.
- Six piece 0 - 11 BA open ended spanner set.
- Multi-purpose snips.
- Seven piece metric hexagon key set.
- Multi-purpose oil.
- 20mm sash tool.
- 100 cable ties.
- Scissors.

HAND TOOLS



**122
PIECES**

Set contents may vary slightly according to product development and availability.

Number of Pieces	Weight each	Order Code	Price/1 TB
122	14.0kg	KEN-595 -3040K	43363.00

PRODUCTS ARE ONLY AVAILABLE VIA YOUR DISTRIBUTOR



KENNEDY PROFESSIONAL **102 Piece Service Engineer's Tool Kit**

Contents

- Hi-impact mobile tool case.
- Six piece 16cm cut 2 needle file set.
- 150mm chrome finish adjustable wrench.
- 150mm mains tester range 125/250V.
- 19mm x 33m insulation tape: black, red and green/yellow pvc.
- Soldering iron 25W 240V.
- Desoldering gun.
- Cable stripping knife.
- 17g 1.0mm diameter 60/40 cored solder.
- Square head centre punch 3.2 x 100mm.
- 150mm/6" flexible rustless rule.
- Precision tweezers: 115mm sharp nose, 120mm flat blade.
- Eye loupe.
- 30mm dia. telescopic inspection mirror (handle expands to 480mm).
- 225g (½lb) ball pein hammer.
- 7.5m/25' steel tape.
- 13 segment blade mini autolock retractable knife.
- Junior hacksaw frame c/w hardened blade.
- 10 junior hacksaw blades for metal.
- 215mm plastic handle scissors.
- Magnetic pick up tool.
- 160mm snipe nose plier.
- 160mm diagonal cutting nipper.
- 160mm combination plier with side cutter.
- 150mm insulation and wire stripping plier.
- 115mm precision flat nose pliers.
- 115mm precision long nose pliers.
- 115mm precision nippers.
- 115mm precision end cutting nippers.
- Pro-Torq grip screwdrivers with chrome vanadium blade: slotted 100 x 6mm; crosspoint 76mm x No.0 and No.1, 6mm x No.2; supadriv 76mm x No.0 and No.1, 100mm x No.2; electrician's: parallel 150 and 200 x 5mm.
- Offset screwdrivers: 5mm x No.1 and 6mm x No. 2.
- 1000V VDU insulated screwdrivers: parallel 4 x 100mm; slotted 5.5 x 125mm.
- Torx screwdrivers: T6, T8 and T10.
- 11 piece screwdriver and tool set: parallel 1, 1.2, 1.4, 1.8, 2.4 and 3mm; crosspoint PHO-2, PHO and PH1, fine point awl and tweezers.
- Seven piece electronic screwdriver set: parallel 1.4, 2, 2.4 and 3mm; crosspoint PHO-3, PHO-2 and PHO.
- Six piece chrome vanadium steel 0 - 11 BA open ended spanner set.
- 20mm dia. sash tool.
- Nine piece hex key set 1.5 - 10mm.
- Chrome vanadium combination spanners: 5.5, 6, 7, 8, 9 and 10mm.



HAND TOOLS

Number of Pieces	Weight each	Order Code	Price/1 TB
102	13.0kg	-3020K	35493.00

Set contents may vary slightly according to product development and availability.

102
PIECES

PRODUCTS ARE ONLY AVAILABLE VIA YOUR DISTRIBUTOR

GROUP 595 TOOL KITS

KENNEDY QUALITY INDUSTRIAL TOOLING **107 Piece Apprentice Engineer's Tool Kit**



- Toolbox • 6 piece Pro-Torq screwdriver set: crosspoint No.1 x 75 and No.2 x 100mm; flared 6.3 x 100 and 8.0 x 250mm; parallel 5 x 100 and 5 x 200mm.
- 6 piece screwdriver set: crosspoint PH0 and PH1; parallel 1.4, 2.0, 2.4, and 3.0mm.
- 6 - 19mm 14 piece metric combination spanner set.
- 9 piece metric hex key set: 1.5 - 10mm.
- 8 piece 2nd cut file set: one each flat, hand, round, half round, 3 square and square.
- 12 piece 2nd cut needle file set: 1 each hand, flat, knife, round, half round, square, 3 square, crossing, round edge joint, slitting, warding and barrette.
- 2 of each grade 0, 1 and 2 emery sheets.
- 200mm/8" adjustable wrench.
- 18 blade metric/inch feeler gauge.
- Magnetic pick-up tool extends to 650mm.
- 7.5m/25ft locking tape rule.
- Snap-off blade knife • Junior hacksaw • 20 junior hacksaw blades.
- 300mm (12") hacksaw frame • 6 hacksaw blades • Shears
- 3 piece professional plier set • 255mm straight jaw grip wrench.
- 6 x 150mm flat cold chisel • 1lb ball pein hammer.
- 175mm engineer's scribe.
- 30mm dia inspection mirror (extends to 650mm).
- Centre punch • 150mm (6") engineer's square.
- 150mm (6") pocket rule.
- 100cc grease gun • Eye loupe.

**107
PIECES**



Set contents may vary slightly according to product development and availability.

Number of Pieces	Weight each	Order Code	Price/1 TB
107	4.2kg	KEN-595 -0500K	18073.00

KENNEDY PROFESSIONAL **Computer Technician's Tool Kit**



- The kit is supplied in a Kennedy® professional tool and lap top bag.
- Hexagon wrench set 1.5 to 6mm.
 - Precision nut driver set 3.0 to 5.0mm
 - Flat blade precision tweezers 170mm.
 - Sharp nose precision tweezers 115mm.
 - 3-in-1 multimeter • Micro diagonal nipper 110mm.
 - Automatic wire stripper 0.2 to 6mm capacity.
 - Insulated VDE Screwdriver Set: Parallel: 2.5x85mm, 4.0x100mm, 5.5x125mm, 6.5x150mm. Crosspoint: No.0x75mm, No.1x100mm, No. 2x100mm.
 - Crimping tool, capacity 8P8C/RJ-45, 6P/RJ-12, RJ-11 and 6P2C.
 - Cable ties, black, 2.5 x 160mm packet of 100.
 - Precision screwdriver set (in zip case): parallel 1.4 x 40mm, 2.0 x 40mm, 2.4 x 75mm, 3.0 x 75mm and 4.0 x 100mm blade length; crosspoint PH0-3 x 40mm, PH0-2 x 75mm, PH-0 x 75mm and PH1 x 100mm blade length.
 - ESD long nose pliers 130mm.
 - ESD bent nose pliers 140mm
 - ESD flat nose pliers 130mm.
 - Edison™ aluminium torch.
 - Black PVC insulation tape 19mm x 33m.
 - Air duster 400ml • Absorbent wipes (pack of 50).
 - Screen wipes (pack of 50).
 - 1x pair Polyco® pure dex antistatic gloves.
 - Non-contact AC voltage detector.
 - Retractable blade knife.
 - Brushes: No.6 and No.10 flat fitch.

**49
PIECES**



Set contents may vary slightly according to product development and availability.

Number of Pieces	Weight each	Order Code	Price/1 TB
49		KEN-595 -3200K	13527.00

HAND TOOLS

KENNEDY PROFESSIONAL 16 Piece Electrician's VDE Tool Bag & Kit



Heavy duty tear-resistant tool bag with velcro fastening flap. Double webbed shoulder strap fixed with metal release clasps. Two removable tool boards inside which have a unique tool storage securing system built in. All tools are VDE approved.

Contents:

Electrician's tool bag (320 x 340 x 125mm). 150mm euro tester will detect 'live' electricity supply. Suitable for AC to 125 - 250V. 3mm wide tip. Conform to **VDE 0630 Part 4**. 145mm (5¾") Pro-Torq grip diagonal nipper 1000V insulated. 160mm (6¾") Pro-Torq snipe nose plier 1000V insulated. 165mm (6½") Pro-Torq engineer's combination plier 1000V insulated. 170mm (6¾") Pro-Torq wire stripper 1000V insulated. 7-pce VDE dual grip screwdriver set: No.0 x 60, No.1 x 80 and No.2 x 100mm, 2.5 x 75, 4.0 x 100, 5.5 x 125 and 6.5 x 150mm. 180mm (7") insulated cable knife, curved blade. 2x small parts storage boxes.



**16
PIECES**

Width (mm)	Depth (mm)	Height (mm)	Order Code KEN-595	Price/1 TB
320	125	340	-3400K	8089.00

17 Piece 'Live Line' VDE Tool Kit



Contents:

Tear-resistant tool roll (600 x 300mm). 190mm euro tester - will detect 'live' electricity supply. Suitable for AC to 125 - 250V. 3mm wide tip. Conform to **VDE 0630 Part 4**. 145mm (6¼") Pro-Torq grip diagonal nipper 1000V insulated. 160mm (6¾") wire stripper, engineers' combination plier and snipe nose plier 1000V insulated. 240mm (9½") water pump box joint pliers 1000V insulated. 200mm adjustable wrench 1000V insulated. 7 piece insulated VDE screwdriver set: parallel: 2.5 x 85, 4.0 x 100, 5.5 x 125 and 6.5 x 150mm; crosspoint: No.0 x 75, No.1 x 100 and No.2 x 200mm. 180mm (7") insulated cable knife curved blade. 210mm (8¼") cable cutter.



Both rolls have a riveted carry handle on the outside.



**17
PIECES**

Width (mm)	Depth (mm)	Height (mm)	Order Code KEN-595	Price/1 TB
320	125	340	-3420K	12175.00

1000V Dual Grip Screwdriver & Plier Set



10 Piece Set

Fully insulated professional high grip dual material handles that are VDE tested up to 1000V. Screwdrivers have magnetic tips, chrome vanadium steel blades and a hanging hole. Pliers have chrome vanadium steel double polished head and joint heads.

Contents:

Screwdrivers:
Crosspoint -
No.0 x 60mm,
No.1 x 80mm,
No.2 x 100mm.
Parallel -
2.5 x 75mm,
4.0 x 100mm,
5.5 x 125mm,
6.5 x 150mm.



**10
PIECES**

Pliers:

6¾" Pro-Torq snipe nose pliers,
6¼" Pro-Torq grip nipper pliers,
6½" Pro-Torq engineering combination pliers.



Number of Pieces	Weight each	Order Code KEN-595	Price/1 TB
10	1.4kg	-1600K	4384.00

KENNEDY 7 Piece Maintenance Tool Kit



MTK7

Contents:

- Chrome adjustable wrench.
- Slotted electrician's VDE screwdriver.
- Slip joint pliers.
- High tensile diagonal cutting nippers.
- Universal combination pliers.
- No.2 crosspoint engineer's screwdriver.
- Flared slotted engineer's screwdriver.
- PVC tool roll.

**7
PIECES**

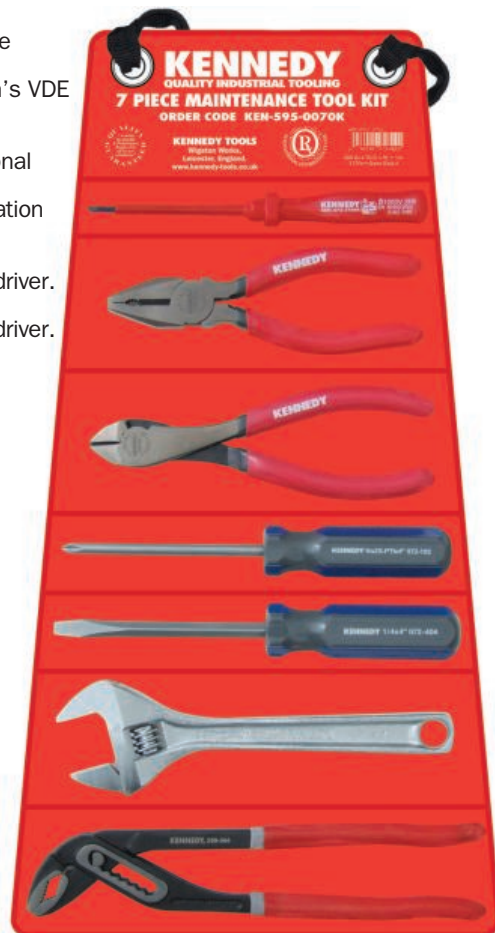

Number of Pieces	Weight each	Order Code KEN-595	Price/1 TB
7	1.3kg	-0070K	3328.00

HAND TOOLS

GROUP 595 TOOL KITS

SENATOR QUALITY TOOLING 33 Piece Home Handyman Kit

HHK32

Supplied in a robust Tuff-E tool box with a tote tray for carrying tools to the job and a multi-compartment storage box with lid.

Contents:

- 18 piece wood, metal and masonry drill set, 6x wood drills 3, 4, 5, 6, 8 and 10mm; 6x masonry drills 3, 4, 5, 6, 8 and 10mm; 6x HSS drills 3, 4, 5, 6, 8 and 10mm.
- 8 piece fluted handle screwdriver set: flared: 6mm stubby, 3 x 100mm and 8 x 200mm; parallel: 3.2 x 75mm and 4 x 150mm; pozidriv: No.2 stubby, No.1 x 75mm and No.2 x 100mm. • Diagonal cutting nippers 150mm/6".
- Snipe nose pliers with side cutter 150mm/6".
- Linesman pliers 180mm/7".
- 8 segment snap-off blade knife with a contour moulded grip.
- 3m/10ft locking tape rule in a tough plastic case.

Set contents may vary slightly according to product development and availability.

33 PIECES



Number of Pieces	Weight each	Order Code SEN-595	Price/1 TB
33		-0500K	3359.00

HAND TOOLS

51 Piece Home Handyman Tool Kit

HHK51

Supplied in a robust Tuff-E tool box, c/w double latch.

Contents:

- 8 piece fluted handle screwdriver set: flared 6mm stubby, 3 x 100mm and 8 x 200mm; parallel 3.2 x 75mm and 4 x 150mm; pozidriv No.2 stubby, No.1 x 75mm and No.2 x 100mm.
- 10 piece screwdriver bit set: 6mm quick release hex bit adaptor; flat 3, 4, 5, 6 and 8mm; crosspoint No.0, 1, 2 and 3mm.
- 200mm (8") chrome vanadium adjustable spanner.
- 225mm (9") hi-vis magnetic boat level. • 600mm (24") hi-vis girder section level. • 150mm mains tester, range 125/250V.
- 19mm x 33m black PVC insulation tape. • Adjustable telescopic 300mm dia inspection mirror. • 450g (16oz) claw hammer wood shaft. • 3m/10ft hi-vis locking tape. • 13 seg 9mm standard snap-off blade knife. • Retractable trimming knife c/w 5 blades.
- 150mm (6") junior hacksaw frame c/w hardened blade.
- 150mm (6") junior hacksaw blade for metal (10).
- 300mm (12") DIY hacksaw frame.
- 177mm (7") plastic handle household scissors.
- 63mm (2½") half tang filling knife. • 76mm (3") half tang scraper.
- Magnetic pick-up tool extends to 650mm.
- 150mm (6") linesman's plier.
- 125mm (5") snipe nose plier.
- 125mm (5") diagonal cutting nipper.
- 255mm (10") straight jaw grip wrench.
- Bradawl.
- 600 piece wall plug set.

Set contents may vary slightly according to product development and availability.

51 PIECES



Number of Pieces	Weight each	Order Code SEN-595	Price/1 TB
51	7.0kg	-0520K	7209.00

61 Piece Home Handyman Tool Kit

HHK61

Supplied in a robust toolbox c/w double latch.

Contents:

- Tool box with tote and wheels. • 8 piece fluted handle screwdriver set: flared 6mm stubby, 3 x 100mm and 8 x 200mm; parallel 3.2 x 75mm and 4 x 150mm; pozidriv No.2 Stubby, No.1 x 75mm and No.2 x 100mm.
- 10 piece screwdriver bit set: 6mm quick release hex bit adaptor; flat 3, 4, 5, 6, and 8mm; crosspoint No.0, 1, 2 and 3mm.
- 18 piece wood, metal and masonry drill set 3, 4, 5, 6, 8 and 10mm bits. • IDH013 240V 13mm impact drill.
- 200mm (8") chrome vanadium adjustable spanner.
- 225mm (9") hi-vis magnetic boat level.
- 600mm (24") hi-vis girder section level.
- 19mm x 33m black PVC insulation tape.
- 150mm euro tester range 125/250V. • Adjustable telescopic 300mm diameter inspection mirror. • Magnetic pick-up tool extends to 650mm. • Bradawl. • 450g (16oz) claw hammer wood shaft. • 3m/10ft Senlor hi-vis locking tape.
- 13 segment 9mm standard snap-off blade knife.
- Retractable trimming knife c/w 5 blades.
- Junior hacksaw frame c/w hardened blade.
- DIY hacksaw frame. • 177mm (7") plastic handled multi-purpose household scissors.
- 63mm (2½") half tang filling knife.
- 76mm (3") half tang scraper.
- 150mm (6") linesman's plier.
- 125mm (5") snipe nose plier.
- 125mm (5") diagonal cutting nipper.
- 255mm (10") straight jaw grip wrench.
- 22" x 8pts homesaw hand saw.

Set contents may vary slightly according to product development and availability.

61 PIECES



Number of Pieces	Weight each	Order Code SEN-595	Price/1 TB
61	16kg	-0540K	12875.00

KENNEDY **22 Piece Plumber's Kit**
QUALITY INDUSTRIAL TOOLING

Supplied in a robust toolbox c/w double latch.

Contents:

- Tool box. • 255mm (10") stillson wrench.
- 3 - 22mm capacity tubing cutter.
- 3 - 41mm tube deburrer.
- 9.5 - 32mm basin wrench.
- 300mm girder section spirit level.
- Telescopic inspection mirror.
- Junior hacksaw frame c/w hardened blade.
- Pad saw.
- 255mm groove slip joint waterpump plier.
- 6 piece flat wood bit set 9.5 - 25mm.
- 12mm x 12m PTFE thread sealing tape to **BS6920**.
- 100g fluxite paste.
- Powerflow lead free solder 3.25mm 250g.
- 3 row plastic handle wire scratch brush.
- 450g grade 2 wire wool.
- Blow lamp and 2175 gas cartridge.



22 PIECES

Number of Pieces	Weight each	Order Code	Price/1 TB
22		KEN-595	8239.00
		-4010K	

KENNEDY **29 Piece Pro-Torq Maintenance Tool Bag & Kit**
PROFESSIONAL



Contents:

- Electrician's tool bag (320 x 340 x 125mm).
- 2x small bits organiser cases. One tool board unique system to secure tools whilst in transit. 140mm (5½") autoloader and lock knife - 13 segment snap-off blade. 165mm (6½") Pro-Torq diagonal nippers. 150mm (6") Pro-Torq snipe nose pliers with side cutter. 150mm (6") Pro-Torq combination pliers.
- Six piece Pro-Torq screwdriver set: crosspoint No.1 x 75, No.2 x 100; flared 6.3 x 100, 8.0 x 200; parallel 5.0 x 75, 5.0 x 150mm.
- Seven piece Pro-Torq precision screwdriver set: parallel tips 1.4, 2.0, 2.4 and 3.0mm; crosspoint tips PH0-3, PH0-2 and PH-0.
- 200mm (8") soft grip phosphate adjustable wrench.
- Eight piece Pro-Torq hex wrench set on clip 1.5 - 8.0mm.



29 PIECES

Width (mm)	Depth (mm)	Height (mm)	Order Code	Price/1 TB
320	125	340	KEN-595	8117.00
			-3440K	

SENATOR **47 Piece Engineer's Workshop Tool Kit**
QUALITY TOOLING

- Six piece 16cm cut 2 assorted needle file set.
- 10x 12 x ½" x 18T all hard hacksaw blades.
- 8" (200mm) C/V adjustable spanner.
- 6" (150mm) stainless steel rule with pocket clip.
- Metric and inch feeler gauge, blade length: 60mm.
- 1lb ball peen hammer with hickory shaft.
- 16oz black rubber mallet with wooden shaft.
- 5m/16ft locking tape rule with chrome casing.
- 8 segment 18mm heavy duty snap-off blade knife.
- Retractable trimming knife. • 12" DIY hacksaw.
- 6" heavy duty snipe nose pliers with side cutter.
- 6" diagonal cutting nipper. • 7" linesman pliers.
- 10" multiple slip joint plier.
- 10" straight blade tinsnip.
- 10" straight jaw high strength grip wrench.
- 8 piece fluted handle screwdriver set.
- 7 piece 6 - 19mm drop forged open-ended spanner set.
- 21" five tray cantilever toolbox.



47 PIECES

Set contents may vary slightly according to product development and availability.



Number of Pieces	Weight each	Order Code	Price/1 TB
47	6.4kg	SEN-595	7209.00
		-0700K	

45 Piece Pro-Torq Maintenance Tool Roll Kit

Contents:

- Tear-resistant tool roll (600 x 300mm). 140mm auto-load and lock knife - 13 segment snap-off blade. Telescopic magnetic pick-up tool extends to 550mm (22"). 150mm (6") Pro-Torq snipe nose pliers with side cutter. 165mm (6") Pro-Torq diagonal nippers.
- Six piece Pro-Torq screwdriver set: crosspoint No.1 x 75, No.2 x 100; flared 6.3 x 100, 8.0 x 200; parallel 5.0 x 75, 5.0 x 150mm.
- 14 piece chrome vanadium combination spanner set 6 - 19mm.
- Three piece offset screwdriver set: No.1 crosspoint x ¾" parallel, No.2 crosspoint x ¼" parallel and No.3 crosspoint x 5/16" parallel.
- Seven piece Pro-Torq precision screwdriver set: parallel tips 1.4, 2.0, 2.4 and 3.0mm; crosspoint tips PH0-3, PH0-2 PH-0.
- 200mm (8") soft grip phosphate adjustable wrench. Eight piece Pro-Torq hex wrench set on clip 1.5 - 8.0mm.



Group 534

45 PIECES



Width (mm)	Height (mm)	Order Code	Price/1 TB
330	600	KEN-595	11147.00
		-3460K	

PRODUCTS ARE ONLY AVAILABLE VIA YOUR DISTRIBUTOR

HAND TOOLS

GROUP 595 CYCLE TOOLS

SENATOR CYCLONE *Cycle Work Stand*

CWS152

Quick to set up, this fold-away cycle work stand has telescopic height adjustment, and plastic jaw clamps to securely grip the frame or seat post.

Specifications:

Construction: light alloy and tough ABS Plastic, rubber feet.

Dimensions: closed: 23 x 22 x 102cm,
open: 70 x 100 x 164cm.

Jaw opening: min: 25mm diameter, max: 75mm diameter.
Weight: 5.3kg.



Cycle not included



Product Number	Order Code	Price/1 TB
CWS152	SEN-595 -4480K	9269.00

15 Piece Cycle Repair Kit

This comprehensive kit is ideal for cycle repairs at home, comes in its own wallet and measures 90 x 200 x 40mm. Large than the multi tools but still small enough to carry in a ruck sack or pannier for those touring holidays.

Contents:

- 2x 'Y' box wrenches: 8, 9, 10mm and 12, 13 and 14mm.
- 150mm (6") adjustable wrench 20mm max. opening.
- Hook spanner with 15 and 16mm open ended cone wrench.
- Screwdriver handle: crosspoint No.1 and No.2.
- Slotted bits: 4 and 6mm.
- 3x hex key wrenches: 4, 5, 6 and 8mm hex adaptor.
- 1x forged steel 'O' spoke adjuster: 10, 11, 12, 13, 14 and 15 G.E. 3x tyre levers.

**15
PIECES**



Number Of Pieces	Order Code	Price/1 TB
15	SEN-595 -4460K	1803.00

SENATOR CYCLONE

These specialist products are made from quality materials to give high levels of performance and durability. Whether you are doing emergency roadside repairs or general maintenance, the **SENATOR CYCLONE** range is all that you would expect from a top supplier of industrial tools.

Cycle Multi-Tools

CMT091 - One of the smallest multi tools on the market. Comfortable in the hand, or in the pocket. It has chrome vanadium steel blades and a matt coated frame.

Includes: Hex keys, 2, 2.5, 3, 4, 5 and 6mm. Torx key T25. No.1 crosspoint bit. 5mm slotted bit.

Product Number	Order Code	Price/1 TB
CMT091	SEN-595 -4420K	455.00



9-in-1

CMT161 - Another very compact multi tool from **SENATOR CYCLONE** range with 16 useful chrome vanadium blades and chain rivet extractor.

Includes: Hex keys: 2, 2.5, 3, 4, 5 and 6mm. Adaptor for 8mm hex key. 1x 10mm spanner. 1.2mm and No.1 crosspoint bits. 1.2mm and 5mm slotted bits. 1x tyre lever. 2x spoke wrenches: 14 and 15 G.E. 1x chain rivet extractor.

Product Number	Order Code	Price/1 TB
CMT161	SEN-595 -4400K	1267.00



16-in-1

20-in-1 Cycle Multi-Tool & Pouch

Superb multi tool for almost every cycling emergency. Robust construction with chrome vanadium steel blades mounted in an attractive plastic and cast steel frame.

Includes: Hex keys: 2, 2.5, 3, 4, 5, 6 and 8mm. Ring spanners: 8, 9, 10, 12 and 14mm. No.2 crosspoint bit. 5mm slotted bit. 2x tyre levers. 3x spoke wrenches: 3.22, 3.33 and 3.45mm. 1x chain rivet extractor.

Product Number	Order Code	Price/1 TB
CMT221	SEN-595 -4430K	1332.00



20-in-1

HAND TOOLS

KENNEDY PROFESSIONAL **Tool Tethers, Lanyards & Accessories**

Any Tool, Tether IT!

Dropped tools are a major cause of workplace injury and fatalities – most of which could be avoided with the correct tethering and use of tools. Safe use of tools at height begins with the tool tether, which acts as a secure attachment point for lanyards and ultimately tool belts and harnesses.

Utilising a patented system developed by Tool@rrest, a pioneering name in the field of tethered tools, Kennedy can Retr@fit almost all new and existing hand tools with a certified, statistically fail-safe tether. This means you can enjoy industry leading tether safety without buying new tools and Retr@fitting can be carried out on your site or in a factory setting in a matter of seconds.

And it doesn't stop there. Kennedy can now offer a complete solution to help prevent tools from falling, including securing of the tools-in-waiting (tools in the work belt or holster) and those in active use.



Lifting Buckets

Rugged, tested and large enough for multiple tools and applications. With eight internal carabiners stitched in to secure tools-in-waiting. 250mm diameter.

CE Certified with serial number for LOLER traceability.

TBB-34C

Standard bucket with open top.

TBB-34T

Toggle drawstring type - recommended for use in situations where untethered fasteners or sockets are being worked with. Closing the drawstring ensures that these loose items are prevented from falling in the event of a bucket tip or drop.

Safe working load: 34kg.



Product Number	Type	SWL	Order Code KEN-596	Price/1 TB
TBB-34C	Open Top	34kg	-1442B	10815.00
TBB-34T	Toggle Closing	34kg	-1445E	11073.00

Retr@t 360 Retracting Lanyard

High-impact resistant polyamide casing. Self cleaning re-wind brake and release mechanism. 360° rotational capability. Patent pending. SP30 cord tensile strength 260kg.

Length: 1.2m (fully extended).

Maximum working capacity: 2.5kg.

TLR-135

Standard lanyard with snap hook carabiner and single harness buckle.



TLR-130

With screw carabiner and non-slip double harness buckle - preferred and specified by off-shore users



Product Number	Max. Working Capacity	Order Code KEN-596	Price/1 TB
TLR-135	2.5kg	-3020K	5408.00
TLR-130	2.5kg	-3010K	5408.00

Wrist Lanyards

Supplied complete with wrist wraps and swivel tail. Toggle style tails are also available - see below.

Maximum working capacity: 2kg.



Product Number	Max. Working Capacity	Order Code KEN-596	Price/1 TB
TWS-20C	2kg	-1574D	2215.00

Lanyard Tails

Wrist lanyard tails for use with Kennedy wrist wraps.

Maximum working capacity: 2kg.



Product Number	Max. Working Capacity	Order Code KEN-596	Price/1 TB
TTW-20S	2kg	-1544D	3193.00
TTW-20T	2kg	-1546F	2833.00

Power Tool WR@P

For use with Li-Ion and Ni-Cad 18V power tools only.

High strength nylon webbing. Innovative, patent-pending design.

Maximum working capacity: 2.5kg.



Product Number	Max. Working Capacity	Order Code KEN-596	Price/1 TB
TPW-18L	2.5kg	-1506F	3605.00

Quick Change Belt Loops

Snap-fit tool belt anchor point for securing tool lanyards.

Maximum working capacity: 2.5kg.



Product Number	Max. Working Capacity	Order Code KEN-596	Price/1 TB
TBL-25Q	2.5kg	-1452B	979.00

Quick Change Tool Lanyard

Stretchable cord surrounded by tubular polyester webbing. Available with a range of tails for easy application on different tools.

Maximum working capacity: 2.5kg

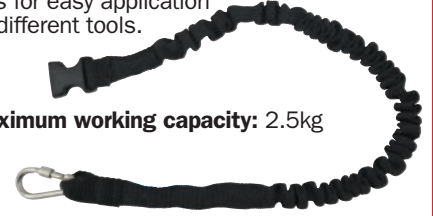

Product Number	Max. Working Capacity	Order Code KEN-596	Price/1 TB
TLE-1QC	2.5kg	-1482B	1648.00

Quick Change Tool Lanyard Tails

For use with Kennedy quick change tool lanyard only.

Maximum working capacity: 2.5kg.



Product Number	Max. Working Capacity	Order Code KEN-596	Price/1 TB
TTQ-25C	2.5kg	-1524D	2575.00
TTQ-25T	2.5kg	-1526F	2421.00

Webbing Lanyards

100cm webbing lanyard. Durable polyester webbing construction. Complete with two stainless steel carabiners.

Maximum working capacity: 2.5kg.



Product Number	Max. Working Capacity	Order Code KEN-596	Price/1 TB
TLW-1C2	2.5kg	-1486F	1288.00

HAND TOOLS

GROUP 597 WOODWORKING TOOLS

KENNEDY PROFESSIONAL Meteor Hand Saws

550mm (22") hand saw with a high quality hardened and tempered steel blade with specially hardened teeth. Stays sharp longer. Fitted with a bi-material handle with fingerline for comfort and accuracy. Three ground edges per tooth. Cuts on back stroke. Designed to cut chipboard, blockboard, timber, plywood, hardboard, plasterboard, PVC and laminates.



8 points per inch (7tpi)



Blade Length	Teeth Per Inch	Weight each	Order Code KEN-597	Price/1 TB
550mm (22")	7	540g	-4900K	823.00
550mm (22")	11	540g	-4920K	823.00

Professional Hand Saw

Superior quality skew back. Hardened and ground steel with glazed and polished blade, tensioned and fully sprung. Teeth are set and sharpened. Polished handle with brass screws. Supplied in wallet with tooth guard. **10 points per inch.**

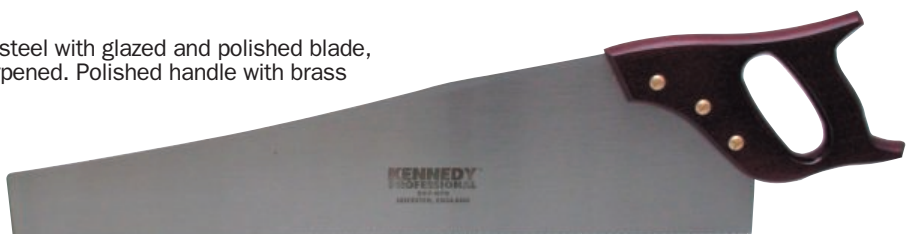

Blade Length	Teeth per inch	Order Code KEN-597	Price/1 TB
560mm (22")	9	-4700K	2730.00

SITESAFE Hardpoint Hand Saw

Hardened and tempered blade. Designed to cut chipboard, blockboard, timber, plywood, hardboard, plasterboard and laminates. Specially hardened teeth to stay sharp longer. Tough handle with fingerline for comfort and accuracy. 8TPI.



Blade Length	Teeth per inch	Order Code SSF-597	Price/1 TB
560mm (22")	8	-4780K	335.00

Hardpoint Veneer Saw

For cutting veneers, and sheet materials. Curved end allows cutting up to skirts and corners. Set and sharpened teeth. High impact moulded plastic handle. Hardened and tempered spring steel blade. 14TPI.



15 points per inch.



Blade Length	Teeth per inch	Order Code SSF-597	Price/1 TB
330mm (13")	14	-5620K	500.00

KENNEDY QUALITY INDUSTRIAL TOOLING Folding Saw Horse - Twin Pack

The Kennedy Saw Horse is designed for supporting wooden planks and boards and is recommended for use in pairs. It has spreader bars for extra stability and features a support bar on the top with metric and inch scale and end stops to secure the workpiece in place. Folds flat for easy transportation and storage.

- Non-slip rubber inserts, prevent work piece slipping.
- Folds flat for easy transportation and storage.
- Suitable for on site and workshop use.
- Rated to 100kg per pair.
- Metric and inch scale on the top.
- Waterproof.

Dimensions - open (L x W x H):
52 x 61 x 79.5 cm.
Dimensions - closed (L x W x H):
5.5 x 61 x 82.5 cm.



Max Load per pair	Order Code KEN-597	Price/1 TB
100kg	-8140K	1906.00

KENNEDY QUALITY INDUSTRIAL TOOLING Masonry Saws

Hardened and tempered steel blades with carbide teeth.

Light Concrete Saw
Suitable for cutting cement based building blocks. 17 tungsten carbide tips on alternate teeth.

Masonry Saw
Suitable for cutting man made building blocks, bricks, slate and cement. 35 tungsten carbide teeth.

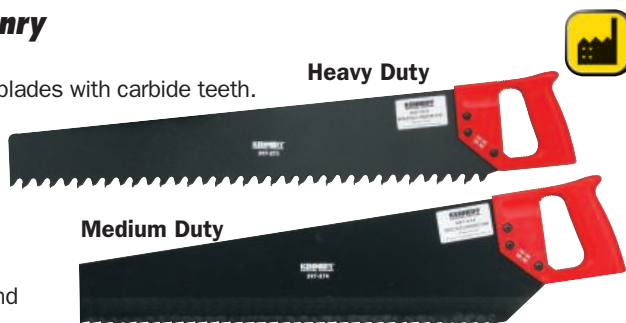

Type	Blade Length	Teeth per inch	Weight each	Order Code KEN-597	Price/1 TB
Medium	622mm	17	1.10kg	-5720K	2369.00
Heavy	490mm	35	1.20kg	-5740K	4685.00

Hardpoint Tenon Saw

Has file sharpened teeth with plain hardened cutting edges. Impact resistant handle. High quality.

13 points per inch.



Blade Length	Weight Per 10	Order Code KEN-597	Price/1 TB
250mm (10")	3.8kg	-4620K	670.00

Professional Tenon Saw

Manufactured from hardened and ground steel with glazed and polished blade, tensioned and fully sprung. Highly polished brass back and handle. Supplied in wallet with tooth guard. **15 points per inch.**



Blade Length	Weight Per 10	Order Code KEN-597	Price/1 TB
250mm (10")	6.0kg	-4600K	3193.00

HAND TOOLS



Flexi Flush Cutting Saw

Suitable for precise cutting in confined areas or around obstructions. Flexible alloy steel blade, which cuts on the pull stroke. Polished rosewood handle with brass ferrule. 20TPI.



Blade Length	Weight each	Order Code KEN-597	Price/1 TB
155mm (6")	120g	-5520K	776.00

Mini Gent's Saws

Suitable for light duty precise cutting. Narrow blade width allows use in confined areas. Polished rosewood handle with brass ferrule.

Blade width: 40mm (1½").



Blade Length	Weight each	Order Code KEN-597	Price/1 TB
150mm (6")	160g	-5560K	1029.00

Reversible Gent's Saw

Suitable for flush cutting in the most awkward corners on the left or right hand side. Reversible offset alloy steel blade cranked and polished with rigid back. Rosewood handle with brass ferrule. 15TPI.



Blade Length	Weight each	Order Code KEN-597	Price/1 TB
250mm (10")	305g	-5400K	1602.00

Steel Back Gent's Saws

Suitable for precise flush cutting. Sprung alloy steel blade with rigid steel back, polished rosewood handle and brass ferrule.

Blade width: 60mm (2¼").



Blade Length	Weight each	Order Code KEN-597	Price/1 TB
200mm (8")	200g	-5480K	1133.00



Pad Saw

Heavy-duty foam grip for maximum comfort. Accepts ½" deep hacksaw blades. Suitable for use in areas of awkward access.



Overall Length	Weight each	Order Code KEN-538	Price/1 TB
210mm (8¼")	130g	-1000K	225.00

Pad Saw

For use in confined spaces.



Blade Length	Weight each	Order Code KEN-597	Price/1 TB
230mm (9")	140g	-5270K	823.00
Spare Blade		-5280K	155.00

Plasterboard Saw

Suitable for rapidly cutting holes in plasterboard. Hardened and tempered carbon steel blade with polished rosewood handle and brass ferrule. 7TPI.



Blade Length	Weight each	Order Code KEN-597	Price/1 TB
150mm (6")	105g	-5660K	964.00

Coping Saw

For cutting and shaping in wood. Steel frame and comfortable wooden handle.

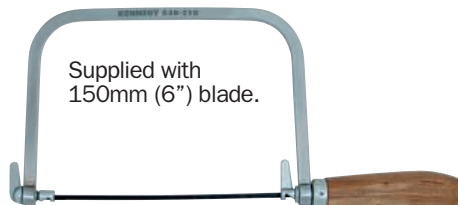

Supplied with 150mm (6") blade.

Overall Length	Weight each	Order Code KEN-538	Price/1 TB
290mm	200g	-2100K	608.00

Spare Coping Saw Blades (to suit above):

Teeth per inch	Pack Quantity	Order Code KEN-040	Price/1 TB
14	10	-1020K	140.00



Hardpoint Compass Saw

Flexible spring blade. Set and sharpened teeth. High impact moulded plastic handle. For cutting apertures and curves in a wide range of materials. Can also be used as a pruning saw.



Blade Length	Teeth per inch	Order Code SSF-597	Price/1 TB
300mm (12")	8	-5340K	411.00

Beechwood Sawing Blocks

Mitre box and block pre-cut at 45° and 90°.



Mitre Box



Internal Size (mm)	Order Code KEN-597	Price/1 TB
230 x 76	-6090K	577.00

Mitre Block

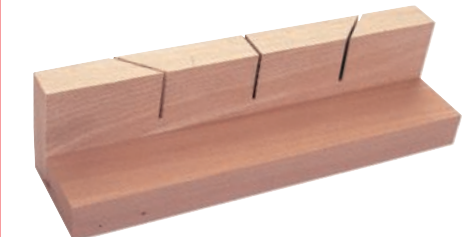

Internal Size (mm)	Order Code KEN-597	Price/1 TB
230 x 76	-6190K	474.00

Bench Hook

Manufactured from the quality beech wood. Hooks into the edge of the bench allowing the workpiece to be held firmly against one end whilst cutting or marking out. Universal - left and right handed.



Internal Size (mm)	Order Code KEN-597	Price/1 TB
230 x 150	-6290K	823.00

Corner Clamp

Ideal for use with wood, angle and tubing. Clamping jaws swivel to accept various widths. Die cast aluminium body with bench mounting.



Base : 158 x 158mm.
Jaw depth: 36mm.
Slot width: 10mm.

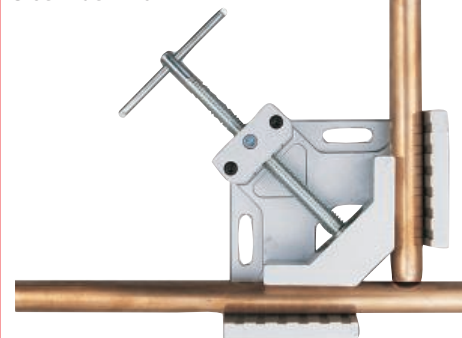

Maximum Clamping	Weight each	Order Code KEN-597	Price/1 TB
70 x 70mm	1.40kg	-6000K	1442.00

HAND TOOLS

Using Your Plane

- Always hold the plane firmly to ensure optimum balance and control. Ensure the workpiece is secure and stand behind the plane - never pull a plane towards your body.
- When planing end-grain, plywood, blockboard or difficult/curl grain, the direction of the cut is extremely important. A 'slice' action is advised or splitting may occur. This is achieved by holding the plane at an angle as shown.
- Splitting can generally be prevented in several ways:
 - 1) By planing towards the centre of the workpiece
 - 2) Bevel the corner of the workpiece before planing
 - 3) Clamp scrap wood level with the edge of the surface being planed and plane it straight across.

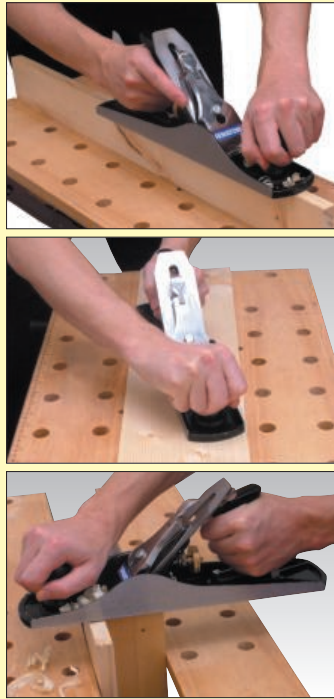

Maintaining Your Plane

- A plane is a precision tool, therefore it should always be treated with care. Always store the plane on its side – this will avoid unnecessary damage to the blade.
- Always sharpen the blade before use. This will make it easier, and safer to use and produce a superior surface finish.
- Before sharpening the blade take the blade out of the plane and remove the cap iron. Always lay the blade cap iron flat on a firm surface before taking out the screw.
- Sharpen your blade using an oilstone. Best results are achieved by using a honing guide - this will give the ideal angle at the cutting edge of the blade.
- Use machine oil to keep the surface of the stone wet but remove excess before use. This is to prevent dust and metal particles from clogging the stone.
- Remove any burrs by laying the front of the blade flat on the oilstone and work it in a "figure-eight" motion.
- Painted surfaces should be sanded or stripped back before planing in order to avoid clogging of the blade and damage to the timber.
- Never plane over nails, this will damage the blade.
- Always wipe the blade with a cloth before replacing it.
- Candle wax applied to the sole of the plane may reduce friction, especially on freshly cut timber.

HAND TOOLS

SENATOR QUALITY TOOLING Block Plane

No. 200

Suitable for any single handed operation in particular for end-grain work. The low angle plane cutter ensures minimal vibration giving an excellent finish on many man made materials such as plastic laminates. Adjustable 40mm width steel cutting blade with ground base and sides for smooth planing. Large screw for accurate adjustments. Cast iron body with adjustable cutter depth and alignment.



Model Number	Length (mm)	Iron Width	Weight each	Order Code SEN-597	Price/1 TB
200	178	41mm	0.80kg	-0990K	1700.00

Smoothing Plane

No. 4

Used for general purpose smoothing and final finishing. Featuring a robust level cap designed to lock down on three points for secure location of the cutting iron. High performance carbon steel blade, hardened and tempered to retain a keen cutting edge to cut even the hardest of woods. Impact resistant ABS resin handle and knob are extremely robust and contoured to fit comfortably in the hand, for maximum control and reduced user fatigue. Suitable for single and two handed operations. Traditional adjusting nut for fine setting.



Model Number	Length (mm)	Iron Width	Weight each	Order Code SEN-597	Price/1 TB
4	247	51mm	1.93kg	-0940K	2318.00

Jack Plane

No. 5

Fully adjustable metal plane for stock removal and truing up long edges or levelling wide boards. Kidney shaped lever cap screw hole prevents accidental slippage of cutter. High performance carbon steel blade, hardened and tempered to retain a keen cutting edge. Fully adjustable frog for all tasks and timber types. Virtually unbreakable polypropylene handle and knob shaped for comfort. Finger tip adjustment for depth of cut and cutter alignment. Tight fitting spring steel cap iron for optimum shaving flow. Cast fine grey iron base for stability and wear resistance. Precision ground base and sides ensure performance to the highest tolerances.

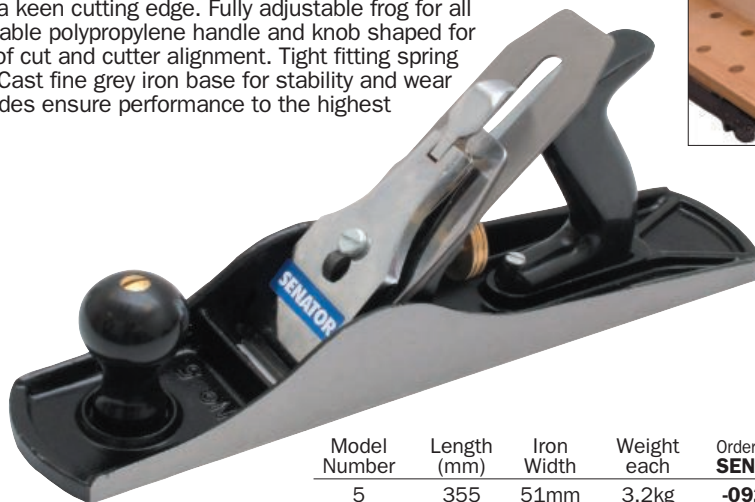

Model Number	Length (mm)	Iron Width	Weight each	Order Code SEN-597	Price/1 TB
5	355	51mm	3.2kg	-0920K	2494.00

KENNEDY *Surface Forming Tools*
QUALITY INDUSTRIAL TOOLING

With tough enamelled alloy bodies and high carbon heat treated steel blades.

Flat File - Straight Handle For straight filing with flat blade as standard. Plastic handle.
Blade length: 255mm.
Blade width: 40mm.
Overall length: 395mm.



Plane For conventional plane type filing. With flat blade as standard. Black plastic handle.
Blade length: 255mm.
Blade width: 40mm.
Overall length: 285mm.



Block Plane For single handed use, giving compactness and precision filing.
Blade length: 140mm.
Blade width: 40mm.
Overall length: 140mm.



Shaver Tool With plastic holder.
Blade length: 63mm.
Blade width: 40mm.
Overall length: 185mm.



Round File - Straight For convex and concave surface shaping. Wooden handle.
Blade length: 255mm. **Blade width:** 16mm. **Overall length:** 360mm.



Tool Style	Blade Length	Blade Width	Overall Length	Weight each	Order Code KEN-597	Price/1 TB
Flat File	255mm	40mm	395mm	400g	-1010K	411.00
Plane	255mm	40mm	285mm	400g	-1070K	603.00
Block Plane	140mm	40mm	140mm	130g	-1110K	258.00
Shaver Tool	63mm	40mm	185mm	60g	-1150K	140.00
Round File	255mm	16mm	360mm	125g	-1240K	205.00

Replacement Blades

To Suit	Blade Type	Weight each	Order Code KEN-597	Price/1 TB
Flat File or Plane	Flat	40g	-2020K	129.00
	Half-Round	40g	-2040K	101.00
Block Plane	Flat	30g	-2060K	102.00
Shaver Tool	Curved	10g	-2080K	78.00
Round File	Round	40g	-2100K	205.00

Cabinet Scraper Set

For fine surface finishing of intricate contour surfaces. Used to manually remove small amounts of material and excels in tricky grain areas where hand planes would cause tear out. They will stand up to any heavy-duty scraping task with minimum tear out. For best results, these scrapers should be burnished to a razor sharp edge.

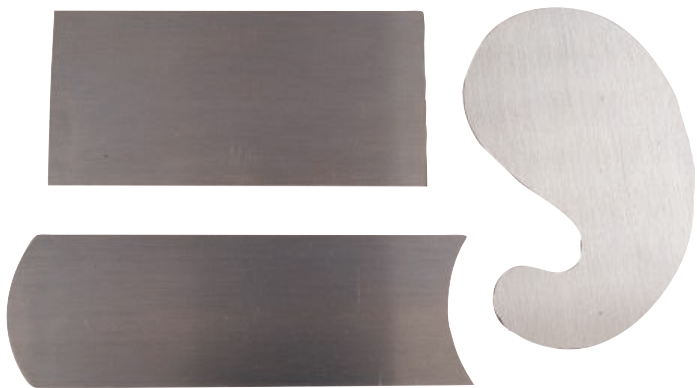

**3
PIECES**

Number of Pieces	Weight Set	Order Code KEN-597	Price/1 TB
3	170g	-7400K	773.00

Chalk Lines

Aluminium Alloy Case

With foldaway locking handle. Heavy-duty robust design, complete with universal hook.



Chalk not included



Line Length	Weight per 12	Order Code KEN-597	Price/1 TB
30m	2.90kg	-7300K	823.00

Die Cast Zinc Alloy Case

With a red satin finish. Complete with folding locking handle. Felt gasket distributes uniform chalk coating onto line. With sliding hatch for filling. Universal hook attaches to any projection or slot.

Chalk not included

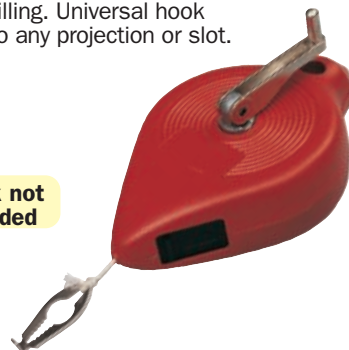

Line Length	Weight per 6	Order Code KEN-597	Price/1 TB
30m	2.30kg	-7320K	617.00

Chalk Line Refills - Large

Suitable for all chalk lines. Good colour fastness and weather resistance. Supplied in squeezable bottle.

Available in three colours:

Blue for general use externally and internally.

Red for exterior masonry work indelible in use.

White for interior use such as fixing a dado rail.



**250gm
NOW AVAILABLE**

Colour	Weight each	Order Code KEN-597	Price/1 TB
Blue	100g	-7330K	147.00
Red	100g	-7340K	147.00
White	100g	-7350K	147.00
Blue	250g	-7370K	205.00
Red	250g	-7380K	205.00
White	250g	-7390K	205.00

HAND TOOLS

GROUP 597 WOODWORKING TOOLS

SENATOR
QUALITY TOOLING

Turning Tool Set

Contents: three straight gouges, two skew chisels, one V-parting tool, one round nose and one diamond point. HSS steel blades. All supplied in a wooden presentation case.
Blade length: 125mm.
Handle length: 250mm.

**8
PIECES**



Number of Pieces	Weight each	Order Code SEN-597	Price/1 TB
8	2.25kg	-3940K	4378.00

Wood Carving Tool Set

Contents: four straight gouges, two square chisels, two skew chisels, two V-parting tools, one veiner and one spoon bit. Alloy steel blades. All supplied in a quality wooden presentation case.
Blade length: 110mm.
Handle length: 95mm.

**12
PIECES**



Number of Pieces	Weight each	Order Code SEN-597	Price/1 TB
12	1.30kg	-3960K	2059.00



KENNEDY
QUALITY INDUSTRIAL TOOLING

Marking & Mortice Gauges

Beechwood Marking Gauge
For marking wood and laminate parallel to edge, prior to cutting, sawing or chiselling. With plastic thumbscrew.
Capacity: 0 - 150 (6").



Gauge Type	Weight per 12	Order Code KEN-597	Price/1 TB
Marking	1.7kg	-6600K	361.00

Rosewood Mortice Gauge

Manufactured from rosewood. Craftsman quality with pull slide, brass adjustment screw and brass plated head which is wear resistant and improves accuracy. Fitted with a single and a double spur for marking out mortices.
Capacity: 0 - 150mm (6").



Gauge Type	Weight per 12	Order Code KEN-597	Price/1 TB
Mortice	1.7kg	-6650K	1494.00

SENATOR **Carpenter's Chisel Set**

Made from quality materials and complete with its own canvas storage wallet. Bevel edged chrome vanadium blades, hardened, tempered, ground and polished. Comfortable bi-material handles with impact resistant end caps.



Contents: 6mm (1/4"), 13mm (1/2"), 19mm (3/4") and 25mm (1") chisels.

**4
PIECES**

Number of Pieces	Order Code SEN-597	Price/1 TB
4	-2970K	1045.00

Bevel Edge Wood Chisels

Craftsman

Hammer-blow resistant handles. For craftsmen and joiners. Designed to give a lifetime of high performance. Chrome vanadium alloy blades, hardened, tempered, ground and polished. 'CAB' (Cellulose Acetate Butyrate handles).



Blade Width mm	Inch	Weight per 12	Order Code KEN-597	Price/1 TB
6	1/4"	1.90kg	-2800K	387.00
10	3/8"	2.20kg	-2820K	397.00
13	1/2"	2.35kg	-2840K	411.00
16	5/8"	2.50kg	-2860K	493.00
19	3/4"	2.60kg	-2880K	520.00
25	1"	3.00kg	-2900K	542.00
38	1 1/2"	3.85kg	-2940K	547.00

Set



No. of Pieces	Contents	Weight each	Order Code KEN-597	Price/1 TB
4	6, 13, 19, & 25mm	880g	-2980K	2038.00

Professional

'Classic' pattern. For professional carpenters.



Blade Width mm	Inch	Weight per 12	Order Code KEN-597	Price/1 TB
6	1/4"	1.90kg	-2160K	324.00
10	3/8"	2.10kg	-2240K	356.00
13	1/2"	2.20kg	-2320K	357.00
16	5/8"	2.40kg	-2400K	384.00
19	3/4"	2.50kg	-2480K	384.00
25	1"	2.80kg	-2640K	493.00
38	1 1/2"	3.70kg	-2680K	520.00

Set



No. of Pieces	Contents	Weight each	Order Code KEN-597	Price/1 TB
4	6, 13, 19, & 25mm	800g	-2970K	2138.00



HAND TOOLS

KENNEDY Auger Bits
QUALITY INDUSTRIAL TOOLING®

American pattern with solid single twist. Spur point and hexagon shank for use with hand and power tools.



SENATOR Forstner Bits
QUALITY TOOLING



For precision hole boring. Self piloting point combined with trepanning style cutting action will produce overlapping holes in any direction. Ideal for scroll and scalloping applications. Suitable for use in bench and pillar drills to bore a wide range of timber, plastics and other materials.



Diameter (mm)	Overall Length (mm)	Weight each	Order Code SEN-597	Price/1 TB
10	90	45g	-5100K	160.00
12	90	45g	-5120K	160.00
15	90	60g	-5150K	165.00
16	90	65g	-5160K	176.00
18	90	65g	-5180K	182.00
20	90	70g	-5200K	182.00
22	90	70g	-5220K	182.00
25	90	90g	-5250K	182.00
26	90	90g	-5260K	182.00
28	90	95g	-5280K	182.00
30	90	105g	-5300K	182.00
35	90	120g	-5350K	183.00
40	90	165g	-5400K	258.00
45	90	180g	-5450K	361.00
50	90	200g	-5500K	411.00

Boxed Sets

Contents:

5 Piece: 1x each 15, 20, 25, 30 and 35mm.

15 Piece: 1x each 10, 12, 15, 16, 18, 20, 25, 26, 28, 30, 35, 40, 45 and 50mm.

**5
PIECES**

**15
PIECES**



Number of Pieces	Weight each	Order Code SEN-597	Price/1 TB
5	0.70g	-5650K	926.00
15	2.30g	-5670K	3348.00

HAND TOOLS

Cutting Dia. (mm)	(Inch)	Overall Length (mm)	Weight each	Order Code KEN-597	Price/1 TB
6mm Hexagon Shank					
6	1/4"	230	60g	-3030K	102.00
7mm Hexagon Shank					
9	3/8"	230	40g	-3070K	208.00
13	1/2"	230	130g	-3110K	208.00
16	5/8"	230	110g	-3150K	266.00
8mm Hexagon Shank					
19	3/4"	230	240g	-3190K	319.00
9mm Hexagon Shank					
22	7/8"	230	300g	-3230K	335.00
25	1"	230	260g	-3280K	420.00

Boxed Set

Set contents: 6, 9, 13, 16, 19, 22 and 25mm.

**7
PIECES**



Number of Pieces	Weight each	Order Code KEN-597	Price/1 TB
7	860g	-3300K	1494.00

Marketry Punch

Beechwood handle, for piercing holes in veneer and thin wood.



Length x Diameter	Weight each	Order Code KEN-597	Price/1 TB
65 x 3mm	25g	-7250K	222.00

Tacklifter

Beechwood handle, V-cut.



Length	Weight each	Order Code KEN-597	Price/1 TB
195mm	100g	-7150K	459.00

Adjustable Hole Cutter

For use on metal, wood, plastics, laminates and leather etc. Cutting diameter can be infinitely varied within range. Graduated scale with locking screw. For use in three jaw chucks (6.4mm shank).

Maximum cutting thickness:
metal 2mm, wood 8mm.
Overall length: 95mm.
Cutting range: 20 - 76mm.



Weight per 6	Order Code KEN-597	Price/1 TB
950g	-4520K	2163.00

Beechwood Mallet

Traditional carpenter's pattern.



Head Size	Weight each	Order Code KEN-597	Price/1 TB
114mm (4 1/2")	520g	-6450K	682.00

PRODUCTS ARE ONLY AVAILABLE VIA YOUR DISTRIBUTOR

GROUP 597 WOODWORKING TOOLS

SENATOR QUALITY TOOLING 162 Piece Power Bit Set



The Senator® multi-purpose power tool bit set contains a truly comprehensive range of the most commonly used screwdriver bits, nut spinners, Torx bits, drills and adaptors that are suitable for use with hand and power tools. They are supplied in a moulded plastic carry case that has individual storage slots for each piece to ensure you can locate the bit you require easily.

This 162 Piece Senator® Power Bit Set contains:

32x 25mm (1") screwdriver bits consisting of: slotted: 4mm, 5mm (x3), 6mm (x3), 7mm; crosspoint: 0, 1 (x3), 2 (x3); 3x square: S1, S2, S3; hex: 4, 5, 6mm; pozi: No.1, No.2 and No.3; torx: T10, T15, T20, T25, T27, T30 and T40.
 24x 5mm (2") screwdriver bits consisting of: slotted: 5mm (x3), 6mm (x3); Phillips: 1, 2, 3; torx: T10 (x2), T15 (x2), T20 (x2), T25 (x2); 18x nut driver bits consisting of: 3/16", 7/32", 1/4", 9/32", 5/16", 11/32", 3/8", 7/16" and 1/2";
 5x 30mm (12") extra length masonry drills: 4, 5, 6, 8 and 10mm; 11x standard length masonry drills: 3mm (x2), 4mm (x2) 5mm (x2) 6mm (x2), 8mm (x2) and 10mm; 1x screw finder 9x flat wood bits: 10, 11, 12, 14, 16, 18, 20, 22 and 25mm; 17x woodworking drills: 3.0, 3.2, 3.5, 4.0, 4.5, 4.8, 5.0, 5.5, 6.0, 6.5, 7.0, 7.5, 8.0, 8.5, 9.0, 9.5 and 10mm; 5x holesaw with mandrel: 32mm, 38mm, 44mm and 54mm diameter; 1x ruler; 1x centre punch; 1x ratcheting bit driver; 4x drill bit depth stop: 5mm, 6mm, 8mm, and 10mm; 1x countersink; 1x carpenter's pencil.

Dimensions: (W x D x H): 455 x 178 x 297mm.

Gross weight: 3.4kg.

Overall dimensions (W x H x D): 455 x 178 x 297mm.



**162
PIECES**

Number of Pieces	Weight each	Order Code SEN-595	Price/1 TB
162	3.4kg	-3180K	2730.00

HAND TOOLS

KENNEDY QUALITY INDUSTRIAL TOOLING Flat Bits



Forged from high quality tool steel with chip clearance groove and hollow ground point. Centerless ground and true running. Ground spade bit head. For cutting holes in laminates and wood. 6mm hexagon shank to prevent slipping at speed.



Cutting Dia. mm	inch	Overall Length	Weight each	Order Code KEN-597	Price/1 TB
9	3/8"	160	50g	-4070K	57.00
13	1/2"	160	50g	-4110K	59.00
16	5/8"	165	55g	-4150K	70.00
19	3/4"	170	55g	-4190K	80.00
22	7/8"	170	60g	-4230K	85.00
25	1"	170	60g	-4280K	91.00
32	1 1/4"	170	60g	-4290K	106.00

Flat Bit Set
Supplied in wallet.

Contents:
9 (3/8"), 13 (1/2"), 6 (5/8"), 19 (3/4"), 22 (7/8") and 25mm (1").



**6
PIECES**

Number of Pieces	Weight each	Order Code KEN-597	Price/1 TB
6	280g	-4300K	411.00

Adjustable Flat Bits

For cutting holes in wood, plastics etc. Cutting diameter can be infinitely varied within range. Graduated scale with locking screw. For use in three jaw chucks. 9.6mm hexagon shank.
Overall length: 170mm.



Cutting Range	Weight Per 12	Order Code KEN-597	Price/1 TB
25 - 45mm	1.8g	-4400K	2059.00
40 - 76mm	2.8g	-4450K	2575.00

SENATOR QUALITY TOOLING Sidewinder Drills



Titanium nitride (TiN) coated for increased tool life and performance. Standard 118° drill point. 6mm shank diameter suitable for use in electric and air powered drills. The side cutting teeth allow the drill to



be used for producing any size or shape of hole in wood or plastic.



Diameter (mm)	Overall Length	Weight each	Order Code SEN-597	Price/1 TB
6	90mm	150g	-7500K	102.00
8	97mm	150g	-7550K	102.00



Hand Drill

Double pinion drill with die cast body and three jaw keyless chuck. Plastic handle with plastic grips and screw top, for bit storage. Used for small drilling operations.

Extra Grip



8mm Chuck

Overall Length	Weight per 6	Order Code KEN-597	Price/1 TB
215mm	2.80kg	-0600K	823.00



Double Pinion

Heavy-Duty Breast Drill

Heavy-duty two speed breast drill with a heavy cast construction and enclosed gearing. Fitted with a three jaw keyless 13mm chuck and supplied with two removable wooden handles. The plate is pressed against the chest to force the drill point into the work.



13mm Chuck

Folds flat for storage

Overall Length	Weight each	Order Code KEN-597	Price/1 TB
330mm	1.10kg	-0640K	2241.00

Sliding Bevels

Used for marking regular and irregular angles. The 9" sliding steel blade can be locked into any position using the brass thumbscrew. Rosewood stock with brass tips for greater wear resistance.



Head Size	Weight Per 12	Order Code KEN-597	Price/1 TB
190mm	1.95kg	-6750K	927.00
230mm	2.20kg	-6790K	979.00

Try & Mitre Squares

Used for marking out right angles and testing squareness. Rosewood stock with brass face for greater wear resistance. Blades are manufactured from hardened steel, and secured by steel washers with brass rivets. Solid rosewood stock with solid brass facing securely fixed to the stock provides a hard wearing contact edge.



Head Size	Weight Per 12	Order Code KEN-597	Price/1 TB
150mm (6")	2.90kg	-6860K	876.00
230mm (9")	3.80kg	-6890K	926.00

Rafter's Square

Manufactured from hardened and tempered ground steel. Graduated to 2mm on one side and 1/8" and 1/16" increments on the other. In the hands of a skilled carpenter the simple rafter's square becomes an indispensable calculating device of immense capacity. Enabling the carpenter to easily determine the length of any common, hip, valley or jack rafter for any pitch of roof. To make the proper cuts, top and bottom as well as slide or cheek cuts for any rafter.

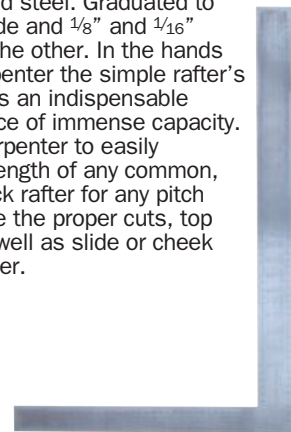

Body Length	Tongue (mm)	Weight per 12	Order Code KEN-597	Price/1 TB
610mm	406	11.1kg	-6950K	698.00

Angle Finder - Magnetic Base

Can be used independently as a 'quick check' tool or to convert a rule or square into a precision angle finder. High strength built-in ceramic magnet with vee groove for use on bars and pipes.

Accuracy: ±0.5%.

For the most accurate readings it is recommended that the angle finder is attached to a steel rule or square by means of the magnet or screws.



Dial Reading	Order Code KEN-597	Price/1 TB
0-90° (Any Quadrant)	-7500K	335.00

Combination Squares

Multi-functional. Can be used as try square, mitre square, depth gauge, spirit level, marking gauge, height gauge and rule. Supplied with scribing tool. Diecast aluminium alloy head with the 6" rule and diecast zinc alloy head with the 12" rule. Precision rolled blades.

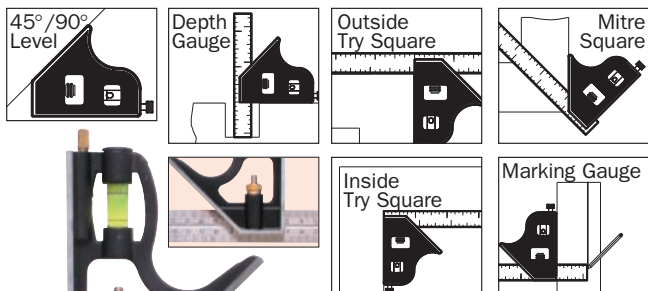

Supplied with scribing tool.

Blade Length	Weight Per 5	Order Code KEN-597	Price/1 TB
150mm/6"	2.80kg	-7060K	777.00
300mm/12"	2.80kg	-7120K	1191.00
Spare Lock Nut & Mandrel for 12"		-7132K	73.00
Spare Scriber for 6"		-7134K	189.00
Spare Scriber for 12"		-7136K	189.00

Beechwood Folding Rules

Made from beechwood for strength and flexibility and painted bright yellow. Metric and inch graduations, large, clear and deep for increased life and easy reading.

Sizes available: 1m x 5 folds: 2m x 10 folds.

Graduations: Metric - mm and cm (cm figures in red) Inch - 1/16", 1/8", 1/4", 1/2", 1".



-3980K

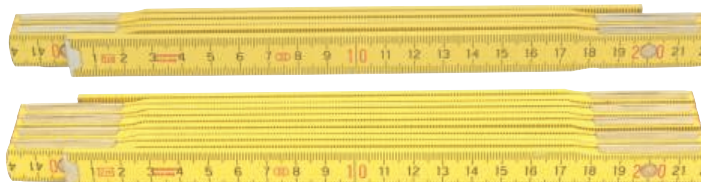

Size	Order Code KEN-518	Price/1 TB
1m x 5 folds	-3980K	322.00
2m x 10 folds	-3990K	573.00

GROUP 601 HEXAGON KEYS

KENNEDY Hexagon Key L-Wrenches
 QUALITY INDUSTRIAL TOOLING

Manufactured from fully hardened carbon steel in accordance with **DIN ISO 2936** ensuring a quality ductile key with precision square cut ends and accurate AF dimensions to ensure full socket contact. Black finish.

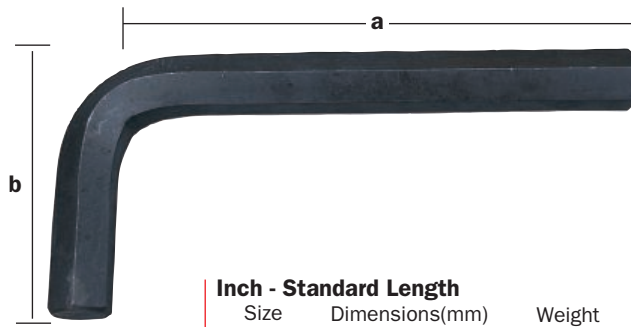

METRIC



Metric - Standard Length

Size (mm)	Dimensions(mm)		Weight per 100	Order Code KEN-601	Price/100 TB
	a	b			
1.5	46.0	15.0	0.95kg	-1150K	443.00
2.0	52.0	18.0	1.93kg	-1200K	555.00
2.5	58.0	20.0	3.36kg	-1250K	661.00
3.0	66.0	23.0	5.52kg	-1300K	776.00
4.0	74.0	29.0	11.4kg	-1400K	1995.00
5.0	85.0	33.0	20.4kg	-1500K	2516.00
6.0	96.0	38.0	33.3kg	-1600K	3139.00
7.0	102.0	41.0	48.5kg	-1700K	4335.00
8.0	108.0	44.0	67.4kg	-1800K	5407.00
10.0	122.0	50.0	119kg	-2100K	8495.00
12.0	137.0	57.0	194kg	-2120K	15460.00
14.0	154.0	70.0	305kg	-2140K	25929.00
17.0	177.0	80.0	517kg	-2170K	37263.00
19.0	199.0	89.0	723kg	-2190K	51594.00
22.0	222.0	102.0	1092kg	-2220K	83692.00
					Price/1
24.0	224.0	90.0		-2240K	1040.00
27.0	250.0	100.0		-2270K	1476.00
32.0	315.0	125.0		-2320K	2133.00

INCH



Inch - Standard Length

Size (inch)	Dimensions(mm)		Weight per 100	Order Code KEN-601	Price/100 TB
	a	b			
0.028"	33	7	0.07kg	-0010K	1163.00
0.035"	33	11	0.08kg	-0020K	1019.00
0.050"	41	13	0.11kg	-0030K	1019.00
1/16"	47	16	0.16kg	-0040K	926.00
5/64"	52	18	0.21kg	-0050K	1019.00
3/32"	58	20	0.32kg	-0060K	1019.00
7/64"	66	23	0.42kg	-0070K	1574.00
1/8"	66	23	0.58kg	-0080K	1111.00
9/64"	72	26	0.77kg	-0090K	2222.00
5/32"	74	29	1.00kg	-0100K	1482.00
3/16"	85	33	1.50kg	-0120K	2130.00
7/32"	91	36	2.16kg	-0140K	2962.00
1/4"	96	38	3.20kg	-0160K	3611.00
5/16"	108	44	4.30kg	-0200K	6295.00
3/8"	122	50	9.20kg	-0240K	9072.00
7/16"	130	53	13.50kg	-0280K	23694.00
1/2"	145	63	19.40kg	-0320K	19622.00
9/16"	154	69	27.00kg	-0360K	28231.00
5/8"	176	76	36.00kg	-0400K	38874.00
3/4"	199	89	62.00kg	-0480K	57847.00
7/8"	222	102	92.00kg	-0560K	59435.00
1"	275	125	128.00kg	-0640K	84003.00

HAND TOOLS

Hexagon Key Walleted Sets

Metric - 9 Piece Set Contents:

1.5 x 45, 2 x 50, 2.5 x 56, 3 x 63, 4 x 70, 5 x 79, 6 x 90, 8 x 100 and 10 x 112mm.

Inch - 10 Piece Set Contents:

1/16" x 1 3/4", 5/64" x 1 7/8", 3/32" x 2", 1/8" x 2 1/4", 5/32" x 2 1/2", 3/16" x 2 3/4", 7/32" x 3", 1/4" x 3 1/4", 5/16" x 3 3/4" and 3/8" x 4 1/4".



Number of Pieces	Weight each	Order Code KEN-601	Price/1 TB
9 (mm)	300g	-2970K	261.00
10 (inch)	290g	-0970K	263.00

Key Ring Sets

Metric - 8 Piece Set Contents:

1.5, 2, 2.5, 3, 4, 5, 5.5 and 6mm.

Inch - 8 Piece Set Contents:

1/16", 5/64", 3/32", 1/8", 5/32", 3/16", 7/32" and 1/4".



Number of Pieces	Weight each	Order Code KEN-601	Price/1 TB
8 (mm)	120g	-2980K	154.00
8 (inch)	110g	-0980K	152.00

Metric/Inch Hexagon Key Set - 20 Piece

Manufactured from high grade carbon steel to international standards **ISO 2936 & DIN 911**.

Supplied in a tough ABS plastic case for easy storage and selection.

Metric - 10 Piece Set Contents: 1.5, 2, 2.5, 3, 4, 5, 6, 7, 8 and 10mm.

Inch - 10 Piece Set Contents: 1/16", 5/64", 3/32", 1/8", 5/32", 3/16", 7/32", 1/4", 5/16" and 3/8".

20 PIECES

Number of Pieces	Order Code KEN-601	Price/1 TB
20	-1060K	931.00
Description	Order Code KEN-593	Price/1 TB
Spare Case for 601-1060K	-4500K	361.00

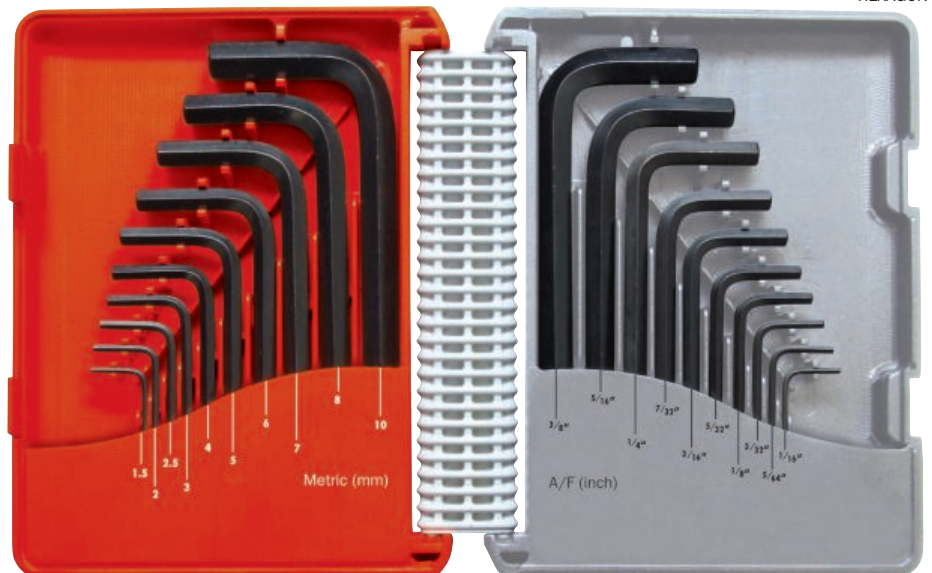

KENNEDY *Hexagon Key*
QUALITY INDUSTRIAL TOOLING **L-Wrenches - Long Arm**

Manufactured from fully hardened carbon steel in accordance with **DIN ISO 2936** ensuring a quality ductile key with precision square cut ends and accurate AF dimensions to ensure full socket contact. Black finish.

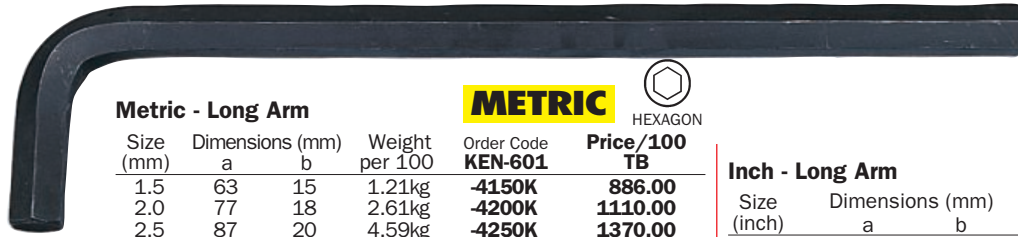

Metric - Long Arm

Size (mm)	Dimensions (mm) a	b	Weight per 100	Order Code KEN-601	Price/100 TB
1.5	63	15	1.21kg	-4150K	886.00
2.0	77	18	2.61kg	-4200K	1110.00
2.5	87	20	4.59kg	-4250K	1370.00
3.0	93	23	7.17kg	-4300K	1596.00
4.0	104	29	14.6kg	-4400K	2393.00
5.0	120	33	26.3kg	-4500K	3155.00
6.0	141	38	44.3kg	-4600K	5148.00
8.0	158	44	89.1kg	-4800K	9256.00
10.0	180	50	158kg	-5100K	12756.00
12.0	202	57	257kg	-5120K	19881.00
14.0	229	70	405kg	-5140K	30696.00
17.0	262	80	684kg	-5170K	48405.00
19.0	280	89	922kg	-5190K	67731.00
					Price/1
22.0	330	80		-5220K	821.00
24.0	370	90		-5240K	1422.00
27.0	420	100		-5270K	1640.00
32.0	500	125		-5320K	2733.00



Inch - Long Arm

Size (inch)	Dimensions (mm) a	b	Weight per 100	Order Code KEN-601	Price/100 TB
1/16"	77	14	0.21kg	-3040K	1574.00
5/64"	82	15	0.31kg	-3050K	1528.00
3/32"	88	17	0.44kg	-3060K	1619.00
7/64"	92	18	0.62kg	-3070K	1619.00
1/8"	96	19	0.79kg	-3080K	1887.00
9/64"	101	20	0.81kg	-3090K	2606.00
5/32"	105	21	1.60kg	-3100K	2606.00
3/16"	114	24	2.20kg	-3120K	3595.00
7/32"	124	26	3.40kg	-3140K	5123.00
1/4"	135	28	4.40kg	-3160K	6200.00
5/16"	151	32	8.00kg	-3200K	10334.00
3/8"	170	35	13.00kg	-3240K	16354.00
1/2"	208	41	28.00kg	-3320K	34326.00
9/16"	228	44	33.00kg	-3360K	45199.00
5/8"	250	48	67.00kg	-3400K	62272.00



Metric 9 Piece Long Arm Set Contents:

1.5 x 77, 2 x 83, 2.5 x 90, 3 x 98, 4 x 106, 5 x 118, 6 x 137, 8 x 156, and 10 x 170mm.

Number of Pieces	Weight each	Order Code KEN-601	Price/1 TB
9	450g	-5970K	359.00



Inch 10 Piece Long Arm Set Contents:

1/16" x 3", 5/64" x 3 3/16", 3/32" x 3 1/2", 1/8" x 3 3/4", 5/32" x 4 1/8", 3/16" x 4 1/2", 7/32" x 4 7/8", 1/4" x 5 5/16", 5/16" x 6", and 3/8" x 6 3/4".

Number of Pieces	Weight each	Order Code KEN-601	Price/1 TB
10	380g	-3970K	361.00



Hexagon T-Handle Wrenches

Manufactured from fully hardened carbon steel. Ergonomically designed handle to provide high grip and torque with user comfort.



Size mm	Overall Length (mm)	Weight each	Order Code KEN-601	Price/1 TB
2.0	150	25g	-6030K	119.00
2.5	150	30g	-6050K	119.00
3.0	150	35g	-6060K	119.00
4.0	190	55g	-6080K	152.00
5.0	190	70g	-6100K	157.00
6.0	225	120g	-6120K	196.00
8.0	225	155g	-6160K	222.00
10.0	225	220g	-6200K	255.00

CV Hex Keys

Chrome vanadium steel with a nickel plating. Manufactured to **DIN ISO 2936**. Supplied in an indexed plastic holder.

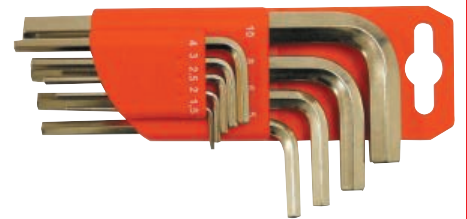

Size (mm)	Overall Length (mm)	Order Code KEN-601	Price/100 TB
1.5	45	-7520K	1093.00
2.0	50	-7540K	1136.00
2.5	55	-7560K	1136.00
3.0	60	-7580K	1136.00
4.0	75	-7600K	1491.00
5.0	85	-7620K	3124.00
6.0	95	-7640K	3052.00
8.0	110	-7660K	3605.00
10.0	120	-7680K	5923.00
9 piece Set	1 of each above	-7990K	906.00/1

KENNEDY PROFESSIONAL Pro-Torq Hex Wrench Sets on Clip

Supplied on robust plastic clips. Keeps all sizes together and readily available. Conveniently folds up to a handy pocket size with penknife type storage. Wrench size stamped on clip.

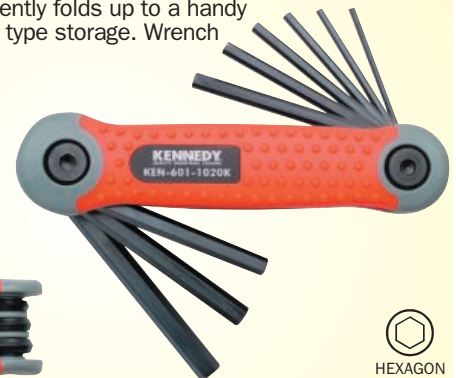

Size	Weight each	Order Code KEN-601	Price/1 TB
5/64" - 1/4"	160g	-1020K	400.00
1.5 - 8mm	160g	-3020K	480.00

Metric 5 Piece Set Contents:
4, 5, 6, 8 and 10mm.



5
PIECES

Metric 8 Piece Set Contents:
2, 2.5, 3, 4, 5, 6, 8 and 10mm.

8
PIECES

Number of Pieces	Weight each	Order Code KEN-601	Price/1 TB
5	685g	-6450K	862.00
8	765g	-6470K	1152.00



PRODUCTS ARE ONLY AVAILABLE VIA YOUR DISTRIBUTOR

GROUP 602 HEXAGON BALL DRIVERS

KENNEDY PROFESSIONAL Pro-Torg T-Handled Hexagon Ball Drivers

Manufactured from hardened carbon steel with a dual material 'T' handle grip for comfort and extra force. The ball drivers can be used at angles of up to 30° for use where access is restricted and the shorter hexagon end is ideal for use when a greater tightening torque is required. Long arm end is ball drive and short arm end plain. Black oxidised finish. Manufactured to **ISO2936/DIN911**.



**8
PIECES**



METRIC



Size (mm)	Overall Length	Order Code KEN-602	Price/1 TB
2.0	130mm	-7010K	329.00
2.5	140mm	-7020K	329.00
3.0	150mm	-7030K	332.00
4.0	160mm	-7040K	332.00
5.0	175mm	-7050K	362.00
6.0	185mm	-7060K	362.00
8.0	195mm	-7080K	362.00
10.0	205mm	-7100K	362.00

8 Piece Set Contents:

2.0, 2.5, 3, 4, 5, 6, 8 and 10mm.

METRIC

Number of Pieces	Weight each	Order Code KEN-602	Price/1 TB
8	750g	-7800K	2525.00

HAND TOOLS

KENNEDY QUALITY INDUSTRIAL TOOLING Ball Driver L-Wrenches

Manufactured from fully hardened carbon steel. A quality ductile key with precision cut ends and accurate AF dimensional to ensure maximum socket contact. Ball end allows up to 30° work offset. Long arm end is ball drive and short arm end plain. Black oxidised finish.

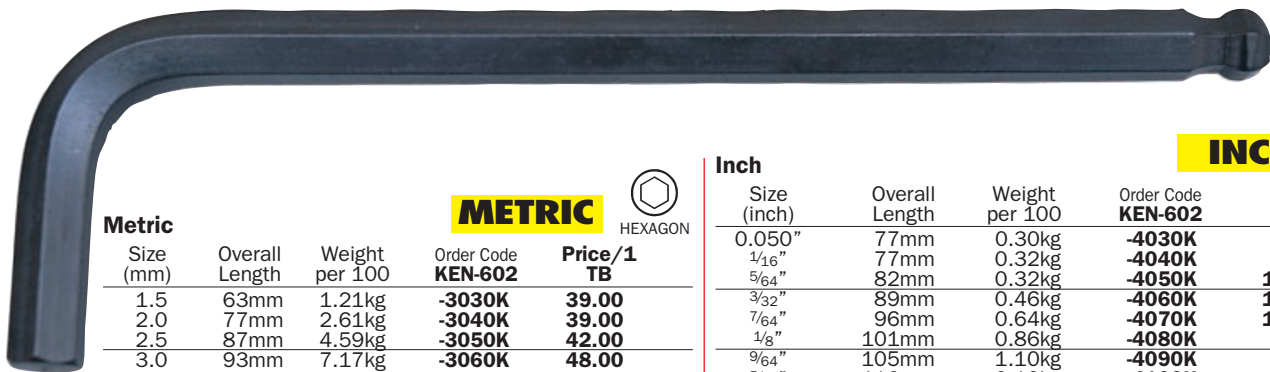

Metric

Size (mm)	Overall Length	Weight per 100	Order Code KEN-602	Price/1 TB
1.5	63mm	1.21kg	-3030K	39.00
2.0	77mm	2.61kg	-3040K	39.00
2.5	87mm	4.59kg	-3050K	42.00
3.0	93mm	7.17kg	-3060K	48.00
4.0	104mm	14.6kg	-3080K	48.00
5.0	120mm	26.2kg	-3100K	58.00
6.0	141mm	44.3kg	-3120K	71.00
7.0	147mm	63.5kg	-3140K	78.00
8.0	158mm	89.1kg	-3160K	107.00
10.0	180mm	158kg	-3200K	155.00

Metric 7 Piece Set Contents:

1.5, 2, 2.5, 3, 4, 5 and 6mm.

Metric 9 Piece Set Contents:

1.5, 2, 2.5, 3, 4, 5, 6, 8 and 10mm.

Supplied in a plastic storage clip.



METRIC



Number of Pieces	Weight each	Order Code KEN-602	Price/1 TB
7	110g	-4570K	350.00
9	350g	-5500K	564.00

Inch

Size (inch)	Overall Length	Weight per 100	Order Code KEN-602	Price/1 TB
0.050"	77mm	0.30kg	-4030K	94.00
1/16"	77mm	0.32kg	-4040K	94.00
5/64"	82mm	0.32kg	-4050K	118.00
3/32"	89mm	0.46kg	-4060K	122.00
7/64"	96mm	0.64kg	-4070K	131.00
1/8"	101mm	0.86kg	-4080K	67.00
9/64"	105mm	1.10kg	-4090K	75.00
5/32"	113mm	2.10kg	-4100K	75.00
3/16"	124mm	2.30kg	-4120K	87.00
7/32"	134mm	3.40kg	-4140K	97.00
1/4"	150mm	2.80kg	-4160K	114.00
5/16"	162mm	8.00kg	-4200K	180.00
3/8"	186mm	26.00kg	-4240K	265.00

Inch 7 Piece Set Contents:

5/64", 3/32", 7/64", 1/8", 9/64", 5/32" and 3/16".

Inch 9 Piece Set Contents:

5/64", 3/32", 1/8", 5/32", 3/16", 7/32", 1/4", 5/16" and 3/8".

Supplied in a plastic storage clip.



INCH



Number of Pieces	Weight each	Order Code KEN-602	Price/1 TB
7	80g	-5580K	350.00
9	370g	-5730K	564.00

KENNEDY *Hexagon T-Handle Ball Drivers*
QUALITY INDUSTRIAL TOOLING

Manufactured from fully hardened carbon steel. Ergonomically designed handle to provide high grip and torque with user comfort.



METRIC

Size (mm)	Overall Length	Order Code KEN-602	Price/1 TB
2.5	150mm	-6050K	153.00
3.0	150mm	-6060K	153.00
4.0	150mm	-6080K	170.00
5.0	190mm	-6100K	176.00
6.0	190mm	-6120K	213.00
8.0	230mm	-6160K	244.00
10.0	230mm	-6200K	280.00

INCH

Size (inch)	Overall Length	Order Code KEN-602	Price/1 TB
3/32"	6"	-6560K	153.00
1/8"	6"	-6580K	153.00
5/32"	7 1/2"	-6600K	170.00
3/16"	7 1/2"	-6620K	176.00
7/32"	9"	-6640K	213.00
1/4"	9"	-6660K	213.00
5/16"	9"	-6700K	244.00
3/8"	9"	-6740K	280.00



METRIC

5 Piece Set Contents:
4, 5, 6, 8 and 10mm.

7 Piece Set Contents:
2.5, 3, 4, 5, 6, 8 and 10mm.



Number of Pieces	Weight each	Order Code KEN-602	Price/1 TB
5	650g	-7650K	1092.00
7	1007g	-7770K	1422.00

CV Ball Drivers

Manufactured from chrome vanadium steel with a nickel plating. Set supplied in an indexed plastic holder. Individual hexagon key slots help to instantly identify missing drivers.



METRIC

Size (mm)	Overall Length	Order Code KEN-602	Price/1 TB
1.5	80mm	-9030K	146.00
2.0	85mm	-9040K	146.00
2.5	90mm	-9050K	216.00
3.0	100mm	-9060K	216.00
4.0	110mm	-9080K	235.00
5.0	130mm	-9100K	279.00
6.0	150mm	-9120K	357.00
8.0	175mm	-9160K	569.00
10.0	200mm	-9200K	853.00
9 Piece Set 1 of each above			-9940K 2556.00

HEXAGON BALL DRIVERS

Extra Long Ball Driver Hex Key Set

Can be used at angles of up to 30°. Manufactured from high grade carbon steel to international standards.

Metric - to ISO 2936:
1.5, 2, 2.5, 3, 4, 5, 6, 7, 8, 10mm.

Inch - to DIN 911:
1/16", 5/64", 3/32", 1/8", 5/32", 3/16", 7/32", 1/4", 5/16", 3/8".



20 PIECES



Tough ABS plastic case for easy storage and selection.

Description	Order Code KEN-593	Price/1 TB
Spare Case to suit 602-280	-4520K	387.00
Number of Pieces	Weight each	Order Code KEN-602
20	940g	-2800K
		Price/1 TB
		1433.00

Hexagon Ball Driver Hand Clip Sets

METRIC

7 Piece Set Contents: 2.5, 3, 4, 5, 6, 8 and 10mm.

INCH

7 Piece Set Contents: 3/32", 1/8", 5/32", 3/16", 1/4", 5/16" and 3/8".



7 PIECES

Description	Number of Pieces	Weight each	Order Code KEN-602	Price/1 TB
Metric	7	360g	-8070K	951.00
Inch	7	465g	-8170K	993.00

KENNEDY PROFESSIONAL Pro-Torq Hexagon Ball Wrench Clip Sets

Conveniently folds up to a handy pocket size with penknife type storage. Moulded handle that gives excellent grip and user comfort.



Dimensions (W x D x H):
40 x 22 x 115mm.

METRIC

8 Piece Set Contents:
1.5 - 8mm.

INCH

9 Piece Set Contents: 5/64" - 1/4".



Description	Number of Pieces	Weight each	Order Code KEN-602	Price/1 TB
Metric	8	169g	-8280K	1060.00
Inch	9	149g	-8390K	1114.00

GROUP 602 HEXAGON BALL DRIVERS

KENNEDY Hexagon Ball Drivers
QUALITY INDUSTRIAL TOOLING



Can be used at angles of up to 30° from the screw head, making them ideal for awkward access areas. Manufactured from hardened carbon steel, available with fluted driver handles, L-wrench pattern or T-handle.



METRIC  HEXAGON

Metric Size (mm)	Blade Length	Weight Per 10	Order Code KEN-602	Price/1 TB
1.5	86mm	65g	-1030K	101.00
2.0	89mm	90g	-1040K	119.00
2.5	99mm	120g	-1050K	119.00
3.0	81mm	200g	-1060K	119.00
4.0	97mm	450g	-1080K	129.00
5.0	109mm	710g	-1100K	134.00
6.0	137mm	910g	-1120K	186.00
8.0	163mm	1580g	-1160K	196.00
10.0	185mm	1840g	-1200K	205.00

INCH  HEXAGON

Inch Size (Inch)	Blade Length	Weight Per 10	Order Code KEN-602	Price/1 TB
1/16"	84mm	90g	-2040K	98.00
5/64"	89mm	110g	-2050K	119.00
1/8"	79mm	200g	-2080K	119.00
9/64"	84mm	400g	-2090K	119.00
5/32"	89mm	550g	-2100K	135.00
3/16"	96mm	1380g	-2120K	135.00
1/4"	119mm	1320g	-2160K	201.00
3/8"	165mm	1530g	-2240K	201.00

Hexagon Ball Driver Sets

Metric 6 Piece Set Contents:
 1.5, 2, 2.5, 3, 4 and 5mm.

Metric 9 Piece Set Contents:
 1.5, 2, 2.5, 3, 4, 5, 6, 8 and 10mm.

Inch 8 Piece Set Contents:
 1/16", 5/64", 1/8", 9/64", 5/32", 3/16", 1/4" and 3/8".

HAND TOOLS



6
PIECES

METRIC  HEXAGON

Number of Pieces	Weight each	Order Code KEN-602	Price/1 TB
6	170g	-2560K	567.00

9
PIECES

METRIC  HEXAGON

Number of Pieces	Weight each	Order Code KEN-602	Price/1 TB
9	640g	-2590K	979.00

8
PIECES

INCH  HEXAGON

Number of Pieces	Weight each	Order Code KEN-602	Price/1 TB
8	480g	-2640K	876.00

KENNEDY *L-Wrench TX Keys*
QUALITY INDUSTRIAL TOOLING

Manufactured from chrome molybdenum steel. Made to manufacturer's standards. Torx is a registered trademark of Camcar Textron.



Size	Length (mm)	Weight each	Order Code KEN-603	Price/1 TB
T6	46	20g	-0060K	107.00
T7	52	20g	-0070K	120.00
T8	52	30g	-0080K	134.00
T9	54	30g	-0090K	113.00
T10	54	40g	-0100K	115.00
T15	58	55g	-0150K	115.00
T20	61	75g	-0200K	126.00

Size	Length (mm)	Weight each	Order Code KEN-603	Price/1 TB
T25	63	100g	-0250K	144.00
T27	69	160g	-0270K	148.00
T30	78	210g	-0300K	150.00
T40	85	310g	-0400K	170.00
T45	92	445g	-0450K	181.00
T50	100	640g	-0500K	189.00
T55	120	1200g	-0550K	203.00

L-Wrench TXS (Tamper-Proof) Keys

TXS tamper-proof TX keys are the same shape as standard TX keys, but have a security hole in the middle.

Manufactured from chrome molybdenum steel.



Size	Length (mm)	Weight each	Order Code KEN-603	Price/1 TB
T8	52	30g	-2080K	154.00
T9	54	30g	-2090K	154.00
T10	54	40g	-2100K	154.00
T15	58	55g	-2150K	154.00
T20	61	75g	-2200K	166.00

Size	Length (mm)	Weight each	Order Code KEN-603	Price/1 TB
T25	63	100g	-2250K	166.00
T27	69	160g	-2270K	171.00
T30	78	210g	-2300K	171.00
T40	85	310g	-2400K	185.00

Driver Style TX Keys

Screwdriver handle style wrenches. Suitable for all applications but particularly favoured for use when replacing shims and inserts on replaceable tipped carbide tooling. Also favoured by the electronics industry. Made from chrome molybdenum steel. Each driver is marked with size.



Size	Length (mm)	Weight each	Order Code KEN-603	Price/1 TB
T6	61	30g	-0060D	470.00
T7	61	32g	-0070D	470.00
T8	72	34g	-0080D	361.00
T9	75	60g	-0090D	371.00

Size	Length (mm)	Weight each	Order Code KEN-603	Price/1 TB
T10	75	60g	-0100D	382.00
T15	92	83g	-0150D	514.00
T20	96	97g	-0220D	583.00
T25	100	100g	-0250D	672.00

KENNEDY *TX Key Ring Set*
QUALITY INDUSTRIAL TOOLING

8 Piece Set Contents: T9, T10, T15, T20, T25, T27, T30 and T40.



Number of Pieces	Weight each	Order Code KEN-603	Price/1 TB
8	120g	-0720K	802.00

KENNEDY *Pro-Torq TX Wrench Set on Clip*
PROFESSIONAL

Eight keys supplied on robust plastic clip. Keeps all sizes together and readily available. Conveniently folds up to a handy pocket size with penknife type storage. Wrench size stamped on clip.



Size	Weight each	Order Code KEN-603	Price/1 TB
T9 - T40	164g	-1680K	820.00

9 Piece Set Contents: T8, T9, T10, T15, T20, T25, T27, T30 and T40. Supplied in a plastic storage clip.



Number of Pieces	Weight each	Order Code KEN-603	Price/1 TB
9	155g	-0760K	799.00

9 Piece Set Contents: T8, T9, T10, T15, T20, T25, T27, T30 and T40. Supplied in a plastic storage clip.



Number of Pieces	Weight each	Order Code KEN-603	Price/1 TB
9	102g	-2680K	1530.00

INDEXA-SEIKI *Flag Type TX Keys*



TX keys for use with external toolholders.

Type Torx Key	Order Code IND-107	Price/1 TB
T6 Flag	-5060K	73.00
T7 Flag	-5070K	73.00
T8 Flag	-5080K	247.00
T9 Flag	-5090K	126.00
T10 Flag	-5100K	274.00
T15 Flag	-5150K	73.00
T20 Flag	-5200K	126.00



GROUP 602 SOCKET SET SCREWS



Page **620 - 621**

GROUP 604 SOCKET HEAD COUNTERSUNK SCREWS



Page **622 - 624**

GROUP 604 SOCKET HEAD BUTTON SCREWS



Page **625 - 626**

GROUP 610 SOCKET HEAD SHOULDER SCREWS



Page **627**

GROUP 615 FASTENER ASSORTMENTS



Page **628 - 635**

GROUP 620 THREAD REPAIR



Page **636**

GROUP 635 WOODSCREWS

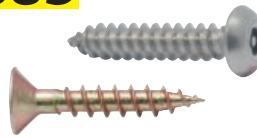

Page **637**

GROUP 639 SCREWED STUDDING



Page **638**

GROUP 644 RIVET NUTS



Page **639**

GROUP 649 CIRCLIPS



Page **640**

GROUP 651 DOWELS PINS



Page **640**

GROUP 662 HOSE CLIPS



Page **642 - 643**

GROUP 600 SOCKET HEAD CAP SCREWS



Page **614 - 619**



FASTENERS

Product Groups
600 - 690

Product Grading



Production

High performance industrial tooling designed for continuous use applications on machine tools where repeatability and long tool life are of critical importance.



Professional

Industrial tooling that has enhanced features and benefits demanded by craftsmen and professional users.



Industrial

Designed for regular use in industrial applications. Manufactured to stringent quality levels and international standards.



Workshop

Standard quality tooling for use by tradesmen and generally industrial use.



Maintenance

Products designed for general maintenance of machines, workshops, garages and some household applications.



Home Improver

DIY quality tooling. Designed for home use and light industrial applications.

Contents

Description	Group	Page
Circlips	649	640
Dowel Pins	650	640
Fastener Assortments	615	628 - 635
Hose Clips	662	642 - 643
Rivet Nuts	644	639
Screwed Studding	670	638
Socket Head Button Screws	604	625 - 626
Cap Screws	600	614 - 619
Countersunk Screws	604	622 - 624
Flange Button Screws	604	626
Shoulder Screws	610	627
Socket Set Screws	602	620 - 621
Thread Repair	620	636
Woodscrews	635	637

GROUP 600 SOCKET HEAD CAP SCREWS

QUALFAST Socket Head Cap Screws - Metric

High Grade Alloy Steel to **BS EN ISO 898/1 Grade 12.9**. Suitable for all high tensile applications. Maximum operating temperature (unplated): 300°C.

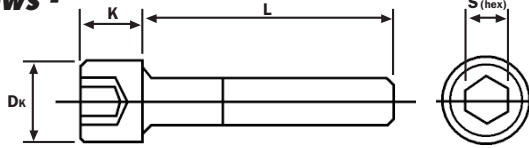
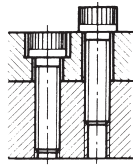

Dimensions to **BS EN ISO 4762 DIN 912**



Threaded to Head as Standard

Thread Size	Dimensions (mm)		
	dk	k	S (hex)
M1.6	3.00	1.6	1.5
M2	3.80	2.0	1.5
M2.5	4.50	2.5	2.0
M3	5.68	3.0	2.5
M4	7.22	4.0	3.0
M5	8.72	5.0	4.0

Size	L	Box Qty	ISO Metric - Self Colour		ISO Metric - Self Colour		ISO Metric BZP		ISO Metric A2 Stainless		
			Order Code QFT-600	Price/100 TB	Order Code QFT-600	Price/100 TB	Order Code QFT-600	Price/100 TB	Order Code QFT-606	Price/100 TB	
M1.6 to M5			ISO Metric - Self Colour		ISO Metric - Self Colour		ISO Metric BZP		ISO Metric A2 Stainless		
Threaded to Head as Standard			Standard (Self-Colour)		Thread to Head (Self-Colour)		Bright Zinc Plated (BZP)		A2 Stainless Steel		
M1.6	4	200	-0905F	8961.00	This Size Range across all Finishes are Supplied Threaded to Head as Standard.	-	-	-	-	-	
	6	200	-0906G	9579.00		-	-	-	-	-	
M2	3	200	-0912N	5305.00		-	-	-	-5913P	9888.00	
	4	200	-0913P	4069.00		-	-	-	-5914Q	10455.00	
	5	200	-0914Q	4249.00		-	-	-	-5915R	10815.00	
	6	200	-0915R	4378.00		-	-	-	-5916S	11382.00	
M2	8	200	-0916S	2720.00		-	-	-	-5917T	11588.00	
	10	200	-0917T	2720.00		-	-	-	-5918V	13442.00	
	12	200	-0918V	2720.00		-	-	-	-5919A	9013.00	
	16	200	-	-		-	-	-	-5919F	10043.00	
M2.5	4	200	-0920T	1957.00		This Size Range Across all Finishes are Supplied Threaded to Head as Standard.	-	-	-	-5919W	9425.00
	5	200	-0920X	1957.00			-	-	-	-5920X	8292.00
	6	200	-0921Y	1983.00			-	-	-	-5921Y	10506.00
	8	200	-0922Z	1983.00			-	-	-	-5922Z	10249.00
M2.5	10	200	-0924A	1983.00			-	-	-	-5924A	11279.00
	12	200	-0925B	2009.00			-	-	-	-5925B	12875.00
	16	200	-0925R	2035.00			-	-	-	-5925M	13442.00
	20	200	-0926F	2575.00			-	-	-	-5926C	14935.00
M3	5	200	-0927D	1020.00			-	-8048Y	750.00	-5927D	4549.00
	6	200	-0928E	397.00			-	-8049Z	750.00	-5928E	1713.00
	8	200	-0929F	397.00			-	-8050A	1900.00	-5929F	1551.00
	10	200	-0930G	284.00			-	-8052C	900.00	-5930G	1194.00
	12	200	-0931H	284.00			-	-8054E	900.00	-5931H	1220.00
	14	200	-0932J	510.00			-	-	-	-	-
	15	200	-0933K	510.00			-	-	-	-	-
	16	200	-0934L	284.00	-		-8056G	950.00	-5934L	1294.00	
	18	200	-0934M	361.00	-		-	-	-5935A	1843.00	
	20	200	-0935M	397.00	-		-8058J	950.00	-5935M	1624.00	
M3	22	200	-0935Z	412.00	-		-	-	-	-	
	25	200	-0936N	454.00	-		-8059K	1200.00	-5936N	1994.00	
	30	200	-0937P	567.00	-		-8061R	1450.00	-5937P	2456.00	
	35	200	-0938Q	794.00	-		-	-	-5938Q	3444.00	
	40	200	-0939C	1247.00	-		-	-	-5938W	5562.00	
	45	200	-0939E	1339.00	-		-	-	-	-	
	50	200	-0939F	1391.00	-		-	-	-	-	
	M4	5	200	-0939R	737.00	This Size Range Across all Finishes are Supplied Threaded to Head as Standard.	-	-	-	-	-
		6	200	-0940S	510.00		-	-8101Q	1300.00	-5940S	2202.00
		8	200	-0941T	361.00		-	-8102R	1300.00	-5941T	1294.00
10		200	-0942V	361.00	-		-8103F	1300.00	-5942V	1146.00	
12		200	-0943W	361.00	-		-8104A	1300.00	-5944X	1096.00	
14		200	-0944X	464.00	-		-	-	-5945Y	2079.00	
15		200	-0945Y	464.00	-		-	-	-	-	
16		200	-0946Z	361.00	-		-8105B	1300.00	-5946Z	1146.00	
18		200	-0947F	454.00	-		-	-	-	-	
20		200	-0948A	361.00	-		-8105T	1400.00	-5948A	1187.00	
M4	22	200	-0948G	412.00	-	-	-	-	-		
	25	200	-0949B	361.00	-	-8106C	1400.00	-5949B	1385.00		
	30	200	-0950C	397.00	-	-8106D	1500.00	-5950C	1657.00		
	35	200	-0951D	397.00	-	-8106F	1550.00	-	-		
	40	200	-0952E	567.00	-	-8107A	1600.00	-5952E	2474.00		
	45	200	-0953F	816.00	-	-	-	-5953F	3444.00		
	50	200	-0954G	816.00	-	-8107J	2100.00	-5954G	3494.00		
	55	200	-0954W	1303.00	-	-	-	-	-		
	60	200	-0954Z	1303.00	-	-8107L	2200.00	-	-		
	65	200	-0955A	1339.00	-	-	-	-	-		
M5	70	200	-0955B	1391.00	-	-	-	-	-		
	75	200	-0955C	1442.00	-	-	-	-	-		
	80	200	-0955D	3605.00	-	-	-	-	-		
	90	200	-0955G	2575.00	-	-	-	-	-		
	100	200	-0955E	6695.00	-	-	-	-	-		
	6	200	-0955H	361.00	This Size Range Across all Finishes are Supplied Threaded to Head as Standard.	-8108P	2300.00	-5956A	2940.00		
	8	200	-0956J	397.00		-8108R	2300.00	-5956J	1583.00		
	10	200	-0957K	397.00		-8109J	2300.00	-5957K	1187.00		
	12	200	-0958L	397.00		-8110A	2300.00	-5958L	1187.00		
	14	200	-0959M	438.00		-	-	-5959M	2083.00		
15	200	-0960N	454.00	-		-	-	-			
16	200	-0961P	397.00	-8111B		2300.00	-5961P	1146.00			
18	200	-0962Q	376.00	-		-	-5962Q	2208.00			
20	200	-0963R	397.00	-8111D		2300.00	-5963R	1220.00			
22	200	-0964S	387.00	-		-8111R	2400.00	-	-		
25	200	-0965T	397.00	-	-8112C	2400.00	-5965T	1385.00			
30	200	-0966V	397.00	-4500A	2369.00	-8113D	2400.00	-5966V	1640.00		
35	200	-0967W	454.00	-4501B	2884.00	-8114E	2400.00	-5967W	1699.00		
40	200	-0968X	454.00	-4502C	2472.00	-8115F	2500.00	-5968X	1929.00		
45	200	-0969Y	680.00	-4503D	4893.00	-8115G	2600.00	-5969Y	2925.00		
50	200	-0970Z	680.00	-4504E	3863.00	-8116G	2750.00	-5969Y	2604.00		

FASTENERS

QUALFAST

Socket Head Cap Screws - Metric

High Grade Alloy Steel to **BS EN ISO 898/1 Grade 12.9**. Suitable for all high tensile applications. Maximum operating temperature (unplated): 300°C.

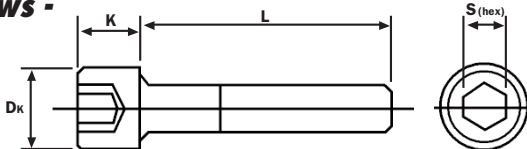
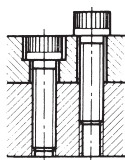

Threaded to Head as Standard

Thread Size	Dimensions (mm)		
	dk	k	S (hex)
M5	8.72	5.0	4.0
M6	10.22	6.0	5.0
M8	13.27	8.0	6.0
M10	16.27	10.0	8.0

Dimensions to **BS EN ISO 4762 DIN 912**

M5 to M10		ISO Metric - Self Colour		ISO Metric - Self Colour		ISO Metric - BZP		ISO Metric A2 Stainless			
Threaded to Head as Standard		Standard (Self-Colour)		Thread to Head (Self-Colour)		Bright Zinc Plated (BZP)		A2 Stainless Steel			
Size	L	Box Qty	Order Code QFT-600	Price/100 TB	Order Code QFT-600	Price/100 TB	Order Code QFT-600	Price/100 TB	Order Code QFT-606	Price/100 TB	
M5 con't	55	200	-0972A	1020.00	-4505F	5408.00	-8116R	3600.00	-	-	
	60	200	-0973B	1020.00	-	-	-8117A	5300.00	-5973B	4770.00	
	65	200	-0974C	1025.00	-	-	-8117J	5900.00	-	-	
	70	200	-0975D	1025.00	-	-	-8118J	5600.00	-5973X	5768.00	
	75	200	-0975K	1025.00	-	-	-	-	-	-	
	80	200	-0975R	1030.00	-	-	-	-	-5974Y	14317.00	
	85	200	-0975S	3605.00	-	-	-	-	-	-	
	90	200	-0975T	1133.00	-	-	-	-	-	-	
	100	200	-0975X	1133.00	-	-	-8118T	5700.00	-5975Z	41973.00	
	110	200	-0975Z	1236.00	-	-	-	-	-	-	
	120	200	-0976A	1545.00	-	-	-	-	-	-	
	130	200	-0976B	2575.00	-	-	-	-	-	-	
	140	200	-0976C	6695.00	-	-	-	-	-	-	
	150	200	-0976D	4275.00	-	-	-	-	-	-	
	M6	6	200	-0976F	361.00	This Size Range Across all Finishes are Supplied Threaded to Head as Standard.	-	-	-	-	-
8		200	-0976E	510.00	-8119H		2300.00	-5976E	2356.00		
10		200	-0977F	510.00	-8119K		2400.00	-5977F	1360.00		
12		200	-0978G	515.00	-8120A		2400.00	-5978G	1204.00		
14		200	-0979H	412.00	-		-	-5979H	2649.00		
15		200	-0980J	205.00	-		-	-	-		
16		200	-0981K	567.00	-8121B		2400.00	-5981K	1227.00		
18		200	-0982L	412.00	-8121C		2400.00	-	-		
20		200	-0983M	567.00	-8122C		2400.00	-5983M	1245.00		
22		200	-0984N	412.00	-		-	-	-		
25		200	-0985P	577.00	-8123D		2400.00	-5985P	1367.00		
30		200	-0986Q	588.00	-8124E		2400.00	-5986Q	1516.00		
35		200	-0987R	588.00	-		-	-5987R	1847.00		
40		200	-0988S	593.00	-4521B		2472.00	-8125A	2500.00	-5988S	1897.00
45		200	-0989T	598.00	-4522C		7983.00	-8125F	2600.00	-5988T	2150.00
50	200	-0990V	603.00	-4523D	3863.00	-8126G	2700.00	-5989T	2150.00		
55	200	-0991W	608.00	-	-	-8127H	2800.00	-5990V	2497.00		
60	200	-0992X	613.00	-4524E	3193.00	-8127J	2900.00	-5991W	3198.00		
65	200	-0993Y	577.00	-	-	-8127K	3400.00	-5992X	3584.00		
70	200	-0994Z	588.00	-4525F	9013.00	-8127L	3500.00	-5993Y	4516.00		
75	200	-0996A	747.00	-	-	-8127M	4000.00	-5994Z	4641.00		
80	200	-0997B	773.00	-4526G	11742.00	-8127N	4100.00	-5996A	4813.00		
85	200	-0997C	1545.00	-	-	-8127P	5800.00	-5997B	6438.00		
90	200	-0998C	763.00	-	-	-	-	-5998C	6850.00		
100	200	-0999D	1339.00	-	-	-8127R	5900.00	-5999D	8807.00		
110	200	-1000E	1545.00	-	-	-8127T	6500.00	-	-		
120	200	-1001F	1545.00	-	-	-8127V	8500.00	-	-		
130	200	-1001H	2472.00	-	-	-	-	-	-		
140	200	-1001K	2575.00	-	-	-	-	-	-		
150	200	-1001P	2678.00	-	-	-	-	-	-		
160	200	-1001T	3193.00	-	-	-	-	-	-		
170	200	-1001V	27295.00	-	-	-	-	-	-		
200	200	-1001W	27810.00	-	-	-	-	-	-		
M8	10	200	-1002G	1020.00	This Size Range Across all Finishes are Supplied Threaded to Head as Standard.	-8128J	2500.00	-6002G	4625.00		
	12	200	-1003H	1020.00		-8128K	2500.00	-6003H	2547.00		
	14	200	-	-		-8128L	2600.00	-6004J	1648.00		
	15	200	-1005K	850.00		-	-	-	-		
	16	200	-1006L	953.00		-8129R	2700.00	-6006L	2365.00		
	18	200	-1007M	958.00		-	-	-	-		
	20	200	-1008N	964.00		-8130A	2700.00	-6008N	2184.00		
	22	200	-1009P	964.00		-	-	-	-		
	25	200	-1010Q	969.00		-8131B	2800.00	-6010Q	2184.00		
	30	200	-1011R	974.00		-8132C	2800.00	-6011R	2381.00		
	35	200	-1012S	979.00		-8132R	2800.00	-6012S	2744.00		
	40	200	-1013T	984.00		-4540A	5923.00	-8133D	2900.00	-6013T	2959.00
	45	200	-1014V	989.00		-	-	-8134E	3050.00	-6014V	3404.00
	50	100	-1015W	994.00		-4541B	6695.00	-8135F	4100.00	-6015W	3584.00
	55	100	-1016X	1236.00		-	-	-8135G	4200.00	-6016X	3881.00
60	100	-1017Y	1236.00	-4542C	4481.00	-8136G	4300.00	-6017Y	4194.00		
65	100	-1018Z	1293.00	-	-	-8136T	4500.00	-6018Z	4770.00		
70	100	-1020A	1391.00	-4543D	13030.00	-8137R	5100.00	-6020A	5052.00		
75	100	-1021B	1442.00	-	-	-8138F	5300.00	-6021B	6644.00		
80	100	-1022C	1494.00	-4544E	13236.00	-8138G	7400.00	-6022C	7159.00		
85	100	-1023A	4635.00	-	-	-	-	-	-		
90	100	-1023D	4738.00	-	-	-8138J	8750.00	-6024E	7931.00		
100	100	-1024E	5150.00	-	-	-8138L	9500.00	-6026G	9785.00		
110	100	-1025F	5100.00	-	-	-8138N	8400.00	-6027H	17974.00		
120	100	-1026G	5200.00	-	-	-	-	-6028J	21012.00		
130	100	-1027H	5300.00	-	-	-	-	-	-		
140	100	-1028J	5900.00	-	-	-	-	-6030H	78126.00		
150	100	-1029K	6500.00	-	-	-	-	-	-		
160	100	-1030L	7500.00	-	-	-	-	-	-		
180	100	-1031M	9500.00	-	-	-	-	-	-		
200	100	-1032N	26000.00	-	-	-	-	-	-		

GROUP 600 SOCKET HEAD CAP SCREWS

QUALFAST Socket Head Cap Screws - Metric

High Grade Alloy Steel to **BS EN ISO 898/1 Grade 12.9.**
 Suitable for all high tensile applications.
 Maximum operating temperature (unplated): 300°C.

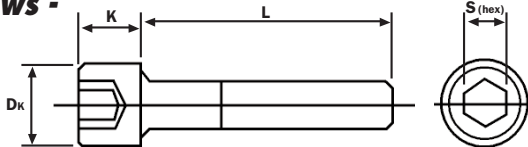
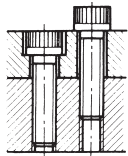

Threaded to Head as Standard

Thread Size	Dimensions (mm)		
	dk	k	S (hex)
M10	16.27	10.0	8.0
M12	18.27	12.0	10.0
M14	21.33	14.0	12.0
M16	24.33	16.0	14.0

Dimensions to **BS EN ISO 4762 DIN 912**

Size	L	Box Qty	ISO Metric - Self Colour		ISO Metric - Self Colour		ISO Metric BZP		ISO Metric A2 Stainless	
			Standard (Self-Colour)	Thread to Head (Self-Colour)	Bright Zinc Plated (BZP)	A2 Stainless Steel				
Order Code	Price/100	Order Code	Price/100	Order Code	Price/100	Order Code	Price/100			
QFT-600	TB	QFT-600	TB	QFT-600	TB	QFT-600	TB			
M10 to M16	10	100	-1033P	2436.00	This Size Range Across all Finishes are Supplied Threaded to Head as Standard.	-	-	-	-	
	12	100	-1034Q	2436.00		-8139B	4600.00	-6037T	5717.00	
	15	100	-1036S	1700.00		-8139G	4700.00	-6038V	3798.00	
	16	100	-1037T	1700.00		-8139T	4800.00	-6039W	3353.00	
	18	100	-1038V	2009.00		-8140A	5047.00	-6041Y	3436.00	
	20	100	-1039W	1700.00		-8140C	5150.00	-6042Z	3501.00	
	25	100	-1041Y	1700.00		-8140G	5253.00	-6044A	4045.00	
	30	100	-1042Z	1700.00		-8140J	5356.00	-6045B	4450.00	
	35	100	-1044A	1751.00		-8141A	5408.00	-6046C	5305.00	
	40	100	-1045B	1803.00		-8141B	5717.00	-6047D	5614.00	
	45	100	-1046C	1854.00		-8141C	5768.00	-6048E	6283.00	
	50	100	-1047D	1906.00		-8142C	6179.00	-6049F	6489.00	
	55	100	-1048E	1957.00		-8142R	6798.00	-6050G	7519.00	
	60	100	-1049F	2009.00		-8142T	6695.00	-6051H	7519.00	
	M10	65	100	-1050G		2060.00	-8142U	7262.00	-6052J	7365.00
70		100	-1051H	2086.00	-8142V	7725.00	-6053K	7622.00		
75		100	-1052J	2112.00	-8142W	8189.00	-6054L	8395.00		
80		100	-1053K	2163.00	-8143A	10100.00	-6055M	9837.00		
90		100	-1054L	2215.00	-8142X	9837.00	-6056N	15502.00		
100		100	-1055M	2266.00	-	-	-6057P	18077.00		
110		100	-1056N	2318.00	-	-	-6058Q	18386.00		
120		100	-1057P	2833.00	-	-	-	-		
130		100	-1058Q	3039.00	-	-	-6060S	31055.00		
140		100	-1059R	2833.00	-	-	-	-		
150		100	-1060S	4635.00	-	-	-	-		
M12		15	100	-1067X	5665.00	This Size Range Across all Finishes are Supplied Threaded to Head as Standard.	-	-	-	-
		16	100	-1068A	7416.00		-8143B	6438.00	-6071D	11382.00
		20	100	-1070C	5665.00		-8143C	6489.00	-6072E	6026.00
		25	100	-1072E	2112.00		-8144A	6592.00	-6073F	6026.00
	30	100	-1073F	2163.00	-8144D		6695.00	-6074G	6644.00	
	35	100	-1074G	2215.00	-8144E		6860.00	-6075H	6644.00	
	40	50	-1075H	2266.00	-8145F		8755.00	-6076J	7725.00	
	45	50	-1076J	2318.00	-8146H		11794.00	-6077K	8189.00	
	50	50	-1077K	2369.00	-8146J		12360.00	-6078L	9116.00	
	55	50	-1078L	2421.00	-		-	-6079M	9631.00	
	60	50	-1079M	2472.00	-		-	-6080N	11382.00	
	65	50	-1080N	2524.00	-		-	-6081P	10970.00	
	70	50	-1081P	2575.00	-4580A		8189.00	-6082Q	11897.00	
	75	50	-1082Q	2632.00	-		-	-6083R	12257.00	
	80	50	-1083R	2678.00	-4581B		12618.00	-	-	
M12	85	100	-1083S	4120.00	-	-	-	-		
	90	50	-1084S	4120.00	-	-	-6084S	14317.00		
	100	50	-1085T	4635.00	-4582C	13287.00	-6085T	16480.00		
	110	50	-1086V	4893.00	-	-	-6086V	18952.00		
	120	50	-1087W	4996.00	-	-	-6087W	19725.00		
	130	50	-1088X	5665.00	-	-	-6088X	23690.00		
	140	50	-1089Y	6695.00	-	-	-6089Y	30076.00		
	150	50	-1090Z	7725.00	-	-	-	-		
	M16	20	25	-1111E	3760.00	This Size Range Across all Finishes are Supplied Threaded to Head as Standard.	-	-	-	-
		25	25	-1112X	3863.00		-8170J	8910.00	-6113Y	13957.00
		30	25	-1113Y	3863.00		-8171K	9064.00	-6114Z	14523.00
		35	25	-1114Z	3863.00		-8172L	13905.00	-6116A	14060.00
		40	25	-1116A	3966.00		-8173M	16429.00	-	-
		45	25	-1117B	4069.00		-8174N	14008.00	-6118C	15708.00
		50	25	-1118C	4120.00		-8175P	17974.00	-	-
55		25	-1119D	4841.00	-8176Q		16377.00	-6120E	18849.00	
60		25	-1120E	4841.00	-8177R		17356.00	-6121F	21321.00	
65		25	-1121F	4841.00	-8178S		17768.00	-6122G	20549.00	
70		25	-1122G	4944.00	-		-	-6123H	23587.00	
75		25	-1123H	6695.00	-		-	-6124J	22197.00	
80		25	-1124J	6695.00	-		-	-	-	
85		25	-1125A	7725.00	-		-	-6125K	25853.00	
90		25	-1125K	9785.00	-		-	-6126L	27295.00	
M18	100	25	-1126L	10815.00	-	-	-	-		
	110	25	-1127M	11845.00	-	-	-	-		
	120	25	-1128N	12360.00	-	-	-	-		
	130	25	-1129P	12463.00	-	-	-6129P	43827.00		
	140	25	-1130Q	12566.00	-	-	-6130Q	48668.00		
	150	25	-1131R	12669.00	-	-	-	-		
	50	25	-1140A	5665.00	This Size Range Across all Finishes are Supplied Threaded to Head as Standard.		-	-		
	60	25	-1142C	6129.00	-	-	-	-		
	70	25	-1144E	6695.00	-	-	-	-		
	80	25	-1146G	7880.00	-	-	-	-		
	90	25	-1147H	8755.00	-	-	-	-		
	100	25	-1148J	9785.00	-	-	-	-		

FASTENERS

QUALFAST *Socket Head Cap Screws - Metric*

High Grade Alloy Steel to **BS EN ISO 898/1 Grade 12.9**. Suitable for all high tensile applications. Maximum operating temperature (unplated): 300°C.

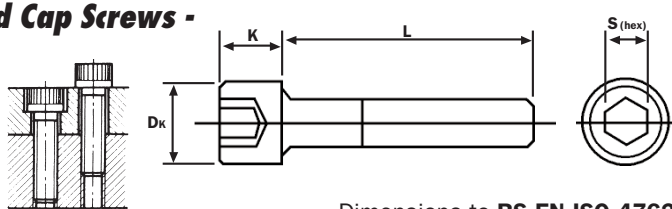

Threaded to Head as Standard

Thread Size	Dimensions (mm)		
	dk	k	S (hex)
M16	24.33	16.0	14.0
M18	27.00	18.0	16.0
M20	30.33	20.0	17.0
M24	36.00	24.0	20.0

Dimensions to **BS EN ISO 4762 DIN 912**

		M16 to M24		ISO Metric - Self Colour		ISO Metric - Self Colour		ISO Metric BZP		ISO Metric A2 Stainless	
		Threaded to Head as Standard		Standard (Self-Colour)		Thread to Head (Self-Colour)		Bright Zinc Plated (BZP)		A2 Stainless Steel	
Size	L	Box Qty	Order Code QFT-600	Price/100 TB	Order Code QFT-600	Price/100 TB	Order Code QFT-600	Price/100 TB	Order Code QFT-606	Price/100 TB	
M16	30	25	-1151M	7571.00	This Size Range Across all Finishes are Supplied Threaded to Head as Standard.	-	-	-	-6151M	42539.00	
	35	25	-1152N	7622.00		-	-	-	-	-	
	40	25	-1153P	7622.00		-	-	-	-6153P	32806.00	
	45	25	-1154Q	7725.00		-	-	-	-	-	
	50	25	-1155R	7828.00		-	-	-	-6155R	32136.00	
	55	25	-1156S	8498.00		-	-	-	-6156S	36256.00	
	60	25	-1157T	7983.00		-	-	-8182F	37595.00	-	
	65	25	-1158V	9734.00		-	-	-8182T	49955.00	-	
M20	70	25	-1159W	9837.00	-	-	-	-	-6159W	37235.00	
	75	25	-1160X	9940.00	-	-	-	-	-	-	
	80	15	-1161Y	10300.00	-	-	-	-	-	-	
	90	15	-1162Z	10352.00	-	-	-	-	-	-	
	100	15	-1164A	10403.00	-	-	-	-	-6164A	48822.00	
	110	15	-1165B	10429.00	-	-	-	-	-	-	
	120	15	-1166C	10434.00	-	-	-	-	-	-	
	130	15	-1167D	15965.00	-	-	-	-	-	-	
	140	15	-1168E	15965.00	-	-	-	-	-	-	
	150	15	-1169F	18025.00	-	-	-	-	-	-	
M24	160	15	-1170G	18098.00	-	-	-	-	-	-	
	180	15	-1171H	21373.00	-	-	-	-	-	-	
	200	15	-1172J	23639.00	-	-	-	-	-	-	
	40	15	-1180S	9785.00	This Size Range Across all Finishes are Supplied Threaded to Head as Standard.	-	-	-	-	-	
	45	25	-1181T	12875.00		-	-	-	-	-	
	50	15	-1182V	32960.00		-	-	-	-	-	
	55	25	-1183W	36050.00		-	-	-	-	-	
	60	15	-1184X	32960.00		-	-	-	-	-	
65	25	-1184Y	33990.00	-		-	-	-	-		
70	10	-1186Z	10300.00	-		-	-	-	-6180M	194258.00	
75	10	-1188A	12875.00	-		-	-	-	-		
M24	80	10	-1189B	18540.00	-	-	-	-	-	-	
	90	10	-1190C	19055.00	-	-	-	-	-	-	
	100	10	-1191D	19570.00	-	-	-	-	-	-	
	110	10	-1192E	22918.00	-	-	-	-	-	-	
	120	10	-1193F	24978.00	-	-	-	-	-	-	
	130	10	-1194G	33990.00	-	-	-	-	-	-	
	140	10	-1195H	77250.00	-	-	-	-	-	-	
	150	10	-1196J	82400.00	-	-	-	-	-	-	
	160	10	-1197K	31415.00	-	-	-	-	-	-	
	180	10	-1198L	83430.00	-	-	-	-	-	-	
200	10	-1199M	44000.00	-	-	-	-	-	-		

Metric/Inch Hexagon Key Set - 20 Piece

Manufactured from high grade carbon steel to international standards **DIN ISO 2936**. Supplied in a tough ABS plastic case for easy storage and selection.

Metric - 10 Piece: 1.5, 2, 2.5, 3, 4, 5, 6, 7, 8 and 10mm.
Inch - 10 Piece: 1/16", 5/64", 3/32", 1/8", 5/32", 3/16", 7/32", 1/4", 5/16" and 3/8".

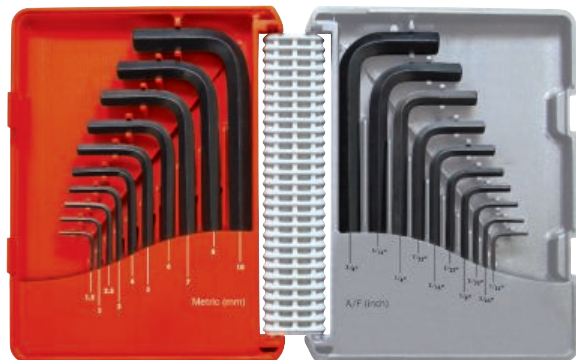

20 PIECES



Description	Order Code	Price/1 TB
20 Piece Hexagon Key Set	KEN-601	931.00
Description	Order Code	Price/1 TB
Spare Case for 601-1060K	KEN-593	361.00
	-4500K	361.00

Hexagon Key Walletted Sets

Metric - 9 Piece Set Contents:

1.5 x 45, 2 x 50, 2.5 x 56, 3 x 63, 4 x 70, 5 x 79, 6 x 90, 8 x 100 and 10 x 112mm.

Inch - 10 Piece Set Contents:

1/16" x 1 3/4", 5/64" x 1 7/8", 3/32" x 2", 1/8" x 2 1/4", 5/32" x 2 1/2", 3/16" x 2 3/4", 7/32" x 3", 1/4" x 3 1/4", 5/16" x 3 3/4" and 3/8" x 4 1/4".



Number of Pieces	Weight each	Order Code	Price/1 TB
9 (mm)	300g	KEN-601	261.00
10 (inch)	290g	-2970K	263.00
		-0970K	263.00

FASTENERS

GROUP 600 SOCKET HEAD CAP SCREWS

QUALFAST Socket Head Cap Screws - Inch

High Grade Alloy Steel to **BS EN ISO 898/1 Grade 12.9**. Suitable for all high tensile applications. Maximum operating temperature (unplated): 300°C.

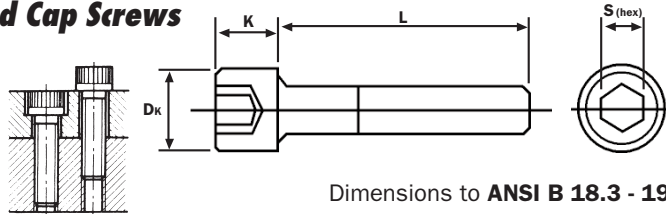

Thread Size	Dimensions (mm)		
	dk	k	S (hex)
2	0.140"	0.108"	1/16"
4	0.183"	0.122"	5/64"
5	0.205"	0.125"	3/32"
6	0.226"	0.138"	3/32"
8	0.270"	0.164"	1/8"
10	0.312"	0.190"	5/32"
1 1/4"	0.375"	0.250"	3/16"
5/16"	0.437"	0.312"	7/32"

Dimensions to **ANSI B 18.3 - 1936 Series**

No.2 to 5/16	UNC - Self Colour		UNC A2 Stainless Steel		UNF - Self Colour		UNF A2 Stainless Steel	
	Order Code	Price/100 TB	Order Code	Price/100 TB	Order Code	Price/100 TB	Order Code	Price/100 TB
Box Qty. 200	Standard (Self-Colour)				Standard (Self-Colour)			
Size L	QFT-601	Price/100 TB	QFT-606	Price/100 TB	QFT-601	Price/100 TB	QFT-606	Price/100 TB
4	1/4"	-1301B 1978.00	-	-	-	-	-	-
	3/8"	-1303D 1869.00	-6514H 3738.00	-	-	-	-	-
	1/2"	-1304E 2079.00	-6514T 4158.00	-	-	-	-	-
	5/8"	-1305F 3148.00	-6515F 6335.00	-	-	-	-	-
	3/4"	-1306G 4198.00	-6515R 8446.00	-	-	-	-	-
	7/8"	-1307H 2992.00	-	-	-	-	-	-
5	3/8"	-1310L 5511.00	-	-	-	-	-	-
	1/2"	-1311M 8189.00	-	-	-	-	-	-
	1/4"	-1315R 2036.00	-6517G 4071.00	-	-	-	-	-
	3/8"	-1317T 1758.00	-6517T 3514.00	-	-	-	-	-
	1/2"	-1318V 1446.00	-6518G 2890.00	-	-	-	-	-
6	5/8"	-1319W 1849.00	-6518R 3697.00	-	-	-	-	-
	3/4"	-1320X 1932.00	-6519F 3863.00	-	-	-	-	-
	1"	-1322Z 2308.00	-6519W 4616.00	-	-	-6480Z 6438.00	-	-
	1/4"	-1327D 1294.00	-	-	-	-	-	-
	3/8"	-1328E 1538.00	-6521G 3076.00	-	-	-	-	-
	1/2"	-1329F 1426.00	-6521R 2851.00	-	-	-	-	-
8	5/8"	-1330G 1856.00	-6522R 3710.00	-	-	-	-	-
	3/4"	-1331H 1719.00	-6523B 3436.00	-	-	-	-	-
	1"	-1333K 2181.00	-6525G 4360.00	-	-	-	-	-
	1 1/4"	-1334L 3962.00	-	-	-	-	-	-
	1 1/2"	-1335M 3080.00	-6526E 6180.00	-	-	-	-	-
	1/4"	-1337P 14060.00	-	-1553D 7004.00	-	-	-	-
	3/8"	-1338Q 4689.00	-6529G 9425.00	-1555F 2168.00	-	-6488E 4334.00	-	-
	1/2"	-1339R 1484.00	-6530A 2967.00	-1556G 1879.00	-	-6489F 3757.00	-	-
	5/8"	-1340S 2226.00	-	-1557H 2049.00	-	-	-	-
	3/4"	-1341T 1742.00	-6532C 3483.00	-1558J 1904.00	-	-6491H 3806.00	-	-
	7/8"	-1342V 2241.00	-	-1559K 2382.00	-	-	-	-
10	1"	-1343W 2006.00	-6533D 4011.00	-1560L 2328.00	-	-6492J 4656.00	-	-
	1 1/4"	-1344X 3864.00	-	-1561M 2665.00	-	-6494L 6541.00	-	-
	1 1/2"	-1345Y 3083.00	-	-1562N 3251.00	-	-	-	-
	1 3/4"	-1346Z 12360.00	-	-1563P 6232.00	-	-	-	-
	2"	-1348A 3703.00	-	-1564Q 4285.00	-	-	-	-
	1/4"	-1349B 8446.00	-	-	-1566S 4111.00	-	-6496N 8240.00	-
	3/8"	-1350C 2509.00	-6539J 5016.00	-1567T 1884.00	-	-6497P 3768.00	-	-
	1/2"	-1351D 1508.00	-6540A 3016.00	-1568V 1821.00	-	-	-	-
	5/8"	-1352E 1754.00	-6541B 3506.00	-1569W 1894.00	-	-6499R 3787.00	-	-
	3/4"	-1353F 1548.00	-6542C 3094.00	-1570X 3563.00	-	-	-	-
	7/8"	-1354G 2657.00	-	-1571Y 2202.00	-	-6500A 4403.00	-	-
	1"	-1355H 1743.00	-6543D 3487.00	-1572Z 2661.00	-	-	-	-
1/4	1 1/4"	-1356J 1991.00	-	-1574A 3554.00	-	-6501B 7107.00	-	-
	1 1/2"	-1357K 2690.00	-6545F 5408.00	-1575B 3630.00	-	-	-	-
	1 3/4"	-1358L 2933.00	-	-1576C 4079.00	-	-	-	-
	2"	-1359M 3319.00	-6547F 6644.00	-1577D 7674.00	-	-	-	-
	2 1/4"	-1360N 5511.00	-	-1578E 9476.00	-	-	-	-
	2 1/2"	-1361P 4236.00	-	-1579F 4329.00	-	-6502C 8704.00	-	-
	1/2"	-1365T 3251.00	-6548E 6541.00	-1580G 6129.00	-	-	-	-
	5/8"	-1366V 3021.00	-	-1581H 2903.00	-	-	-	-
	3/4"	-1367W 2304.00	-6549A 4608.00	-1582J 5614.00	-	-	-	-
	7/8"	-1368X 3220.00	-	-1583K 3157.00	-	-6503D 6335.00	-	-
	1"	-1369Y 2480.00	-6549G 4958.00	-1584L 3157.00	-	-	-	-
	1 1/4"	-1370Z 3083.00	-6550G 6180.00	-1585M 4333.00	-	-	-	-
	1 1/2"	-1372A 3684.00	-6551H 7416.00	-1586N 5408.00	-	-	-	-
5/16	1 1/4"	-1373B 4211.00	-	-1587P 6283.00	-	-	-	-
	2"	-1374C 4246.00	-6553K 8498.00	-1588Q 14060.00	-	-	-	-
	2 1/4"	-1375D 5562.00	-	-1589R 9940.00	-	-	-	-
	2 1/2"	-1376E 5717.00	-6555M 11433.00	-	-	-	-	-
	2 3/4"	-1377F 12412.00	-	-	-	-	-	-
	3"	-1378G 7313.00	-	-	-	-	-	-
	3 1/2"	-1379H 18231.00	-	-	-	-	-	-
	4"	-1380J 17613.00	-	-	-	-	-	-

FASTENERS

SOCKET HEAD CAP SCREWS

QUALFAST

Socket Head Cap Screws - Inch

High Grade Alloy Steel to **BS EN ISO 898/1 Grade 12.9**. Suitable for all high tensile applications. Maximum operating temperature (unplated): 300°C.

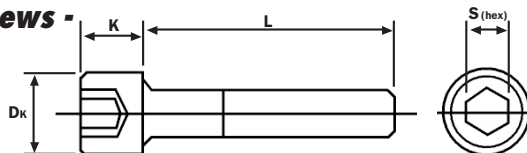
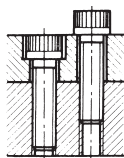

Thread Size	Dimensions (mm)		
	dk	k	S (hex)
3/8"	0.562"	0.375"	5/16"
7/16"	0.656"	0.500"	3/8"
1/2"	0.750"	0.500"	3/8"
5/8"	0.865"	0.620"	1/2"
3/4"	0.990"	0.745"	9/16"
7/8"	1.312"	0.875"	3/4"
1"	1.312"	1.000"	5/8"

Dimensions to **ANSI B 18.3 - 1936 Series**

3/8 to 1			UNC - Self Colour		UNC A2 Stainless Steel		UNF Self Colour		UNF A2 Stainless Steel	
Size	L	Box Qty	Standard (Self-Colour)		A2 Stainless Steel		Standard (Self-Colour)		A2 Stainless Steel	
			Order Code QFT-601	Price/100 TB	Order Code QFT-606	Price/100 TB	Order Code QFT-601	Price/100 TB	Order Code QFT-606	Price/100 TB
3/8	1/2"	100	-1381K	6644.00	-	-	-1591T	14008.00	-	-
	5/8"	100	-1382L	4972.00	-	-	-	-	-	-
	3/4"	100	-1383M	3349.00	-6558E	6747.00	-1593W	5820.00	-6505F	11588.00
	1"	100	-1385P	3319.00	-6560G	6644.00	-1595Y	4455.00	-	-
	1 1/4"	100	-1386Q	3622.00	-6561H	7262.00	-1596Z	4580.00	-	-
	1 1/2"	100	-1387R	3973.00	-6562J	7983.00	-1598A	5820.00	-6507H	11588.00
	1 3/4"	50	-1388S	5081.00	-	-	-1599B	7622.00	-	-
	2"	50	-1389T	5202.00	-6564L	10403.00	-1600C	8601.00	-	-
	2 1/4"	50	-1390V	7571.00	-	-	-1601D	10249.00	-	-
	2 1/2"	50	-1391W	7674.00	-6566N	15296.00	-1602E	10352.00	-	-
	2 3/4"	50	-1392X	11639.00	-	-	-	-	-	-
	3"	50	-1393Y	9013.00	-	-	-1603F	10867.00	-	-
3 1/4"	50	-1394Z	20240.00	-	-	-	-	-	-	
3 1/2"	50	-1396A	16377.00	-	-	-1605H	22094.00	-	-	
4"	50	-1397B	13236.00	-	-	-	-	-	-	
4 1/2"	50	-1398C	21167.00	-	-	-	-	-	-	
5"	50	-1399D	21939.00	-	-	-	-	-	-	
7/16	1"	50	-1401F	11227.00	-	-	-1606J	8858.00	-	-
	1 1/4"	50	-1402G	12824.00	-	-	-1607K	15296.00	-	-
	1 1/2"	50	-1403H	8601.00	-	-	-1608L	10558.00	-	-
	1 3/4"	50	-1404J	9631.00	-	-	-1609M	15965.00	-	-
	2"	50	-1405K	12566.00	-	-	-1610N	18386.00	-	-
	2 1/2"	50	-1407M	18386.00	-	-	-	-	-	-
	3/4"	50	-1408N	10506.00	-	-	-	-	-	-
	1"	50	-1410Q	9167.00	-	-	-1613R	12360.00	-	-
	1 1/4"	50	-1411R	12051.00	-	-	-1614S	12412.00	-	-
	1 1/2"	50	-1412S	9682.00	-6573T	19313.00	-1615T	14472.00	-	-
	1 3/4"	50	-1413T	10970.00	-	-	-1616V	15605.00	-	-
	2"	50	-1414V	11382.00	-6575F	22763.00	-1617W	16841.00	-	-
1/2	2 1/4"	25	-1415W	15553.00	-	-	-1618X	17974.00	-	-
	2 1/2"	25	-1416X	13905.00	-	-	-1619Y	19210.00	-	-
	2 3/4"	25	-1417Y	22351.00	-	-	-	-	-	-
	3"	25	-1418Z	15553.00	-6577H	31055.00	-1622A	22815.00	-	-
	3 1/2"	25	-1421B	20755.00	-	-	-1623B	46762.00	-	-
	4"	25	-1422C	21064.00	-	-	-1624C	32600.00	-	-
	4 1/2"	25	-1423D	25956.00	-	-	-	-	-	-
	5 1/2"	25	-1425F	35072.00	-	-	-	-	-	-
	6"	25	-1426G	40428.00	-	-	-	-	-	-
	1 1/4"	25	-1429K	17201.00	-	-	-1625D	14008.00	-	-
	1 1/2"	25	-1430L	17201.00	-	-	-1626E	25338.00	-	-
	1 3/4"	25	-1431M	26729.00	-	-	-	-	-	-
5/8	2"	25	-1433P	18643.00	-	-	-1628G	24308.00	-	-
	2 1/4"	25	-1434Q	24617.00	-	-	-	-	-	-
	2 1/2"	25	-1435R	22351.00	-	-	-1630J	32909.00	-	-
	2 3/4"	25	-1436S	41818.00	-	-	-	-	-	-
	3"	25	-1437T	26214.00	-	-	-1631K	43157.00	-	-
	3 1/4"	25	-1438V	44084.00	-	-	-	-	-	-
	3 1/2"	25	-1439W	32497.00	-	-	-	-	-	-
	4"	25	-1440X	36720.00	-	-	-1633B	47638.00	-	-
	5"	25	-1442Z	65405.00	-	-	-	-	-	-
	1 1/2"	25	-1452J	34093.00	-	-	-	-	-	-
	1 3/4"	25	-1453K	48616.00	-	-	-	-	-	-
	2"	25	-1454L	37338.00	-	-	-1635P	42591.00	-	-
3/4	2 1/4"	25	-1455M	52994.00	-	-	-	-	-	-
	2 1/2"	25	-1456N	42591.00	-	-	-1642C	25596.00	-	-
	2 3/4"	25	-1457P	104442.00	-	-	-	-	-	-
	3"	25	-1458Q	45475.00	-	-	-1644E	27244.00	-	-
	3 1/2"	25	-1460S	82452.00	-	-	-	-	-	-
	4"	25	-1461T	79722.00	-	-	-	-	-	-
	5"	25	-1463W	125351.00	-	-	-	-	-	-
	6"	25	-1464X	233604.00	-	-	-	-	-	-

FASTENERS

PRODUCTS ARE ONLY AVAILABLE VIA YOUR DISTRIBUTOR

GROUP 602 SOCKET SET SCREWS

QUALFAST Socket Set Screws

High tensile alloy steel. **Grade 14.9.**

Plain Cup - DIN916

For use against hardened shafts. Ideal for use in ductile castings such as zinc, aluminium etc. where high tightening torques are not practical.

Thread Size	S (hex)
M2	1.0
M2.5	1.0
M3	1.5
M4	2.0
M5	2.5
M6	3.0

Knurled Cup - DIN 916

High tensile alloy steel. Grade 14.9.

For quick and permanent location of pulleys, collars and gears on shafts. Will hold fast even in poorly tapped holes. Interrupted profile of clamping face resists loosening due to vibration.

Sizes above M6 are generally counterbored to provide maximum clamping efficiency.

Thread Size	S (hex)
M3	1.5
M4	2.0
M5	2.5
M6	3.0



ISO Metric - Self Colour

M2 to M6

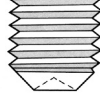

Size	L	Box Qty	Order Code QFT-602	Price/100 TB
M2	3	200	-3052C	309.00
	12	200	-	-
M2.5	3	200	-3065R	309.00
	6	200	-3071Y	670.00
	10	200	-3073A	773.00
M3	3	200	-3079F	309.00
	4	200	-	-
	5	200	-3085M	309.00
	6	200	-	-
	8	200	-	-
	10	200	-3103F	412.00
M3	12	200	-3108L	412.00
	16	200	-3117X	412.00
	4	200	-3122A	412.00
	5	200	-3127F	412.00
M4	6	200	-3132L	412.00
	8	200	-3137R	412.00
	10	200	-3142X	412.00
	12	200	-3147M	412.00
	16	200	-3156L	412.00
	20	200	-3163T	412.00
M5	25	200	-3165H	423.00
	30	200	-	-
	5	200	-3168Z	423.00
	6	200	-3174E	423.00
	8	200	-3179K	423.00
	10	200	-3184Q	423.00
	12	200	-3189W	423.00
	16	200	-3200G	438.00
M6	20	200	-3205M	438.00
	25	200	-3209R	438.00
	30	200	-3211Y	464.00
	35	200	-	-
	6	200	-3218A	515.00
	8	200	-3223F	515.00
	10	200	-3228L	515.00
	12	200	-3233R	515.00
M6	16	200	-3244C	515.00
	20	200	-3249H	515.00
	25	200	-3254N	515.00
	30	200	-3259T	515.00
	35	200	-3264Z	515.00
	40	200	-	-
M8	45	200	-	-
	8	200	-3284V	618.00
	10	200	-3290A	618.00
	12	200	-3294E	618.00
	16	200	-3305R	618.00
	20	200	-3310X	618.00
	25	200	-3316C	721.00
	30	200	-	-
	35	200	-3326N	824.00
	40	200	-3331T	927.00
M10	50	200	-3342E	1957.00
	10	200	-3347K	747.00
	12	200	-3352Q	747.00
	16	200	-3363B	927.00
	20	200	-3368G	927.00
M12	25	200	-3373M	1030.00
	40	200	-3389D	2575.00
	50	200	-3398F	3090.00
	12	200	-3403T	721.00
	16	200	-3414E	721.00
M12	20	200	-3419K	721.00
	25	200	-3424Q	824.00
	30	200	-	-

ISO Metric A2 Stainless Steel



Size	L	Box Qty	Order Code QFT-606	Price/100 TB
M2	3	200	-8010A	6644.00
	12	200	-8016G	10300.00
M2.5	3	200	-8023B	6541.00
	6	200	-8026E	7725.00
	10	200	-8028G	14214.00
	3	200	-8077D	3348.00
M3	4	200	-8080G	1442.00
	5	200	-8083K	1545.00
	6	200	-8088Q	1545.00
	8	200	-8093W	1545.00
	10	200	-8099B	1700.00
	12	200	-8104G	2318.00
	16	200	-8114S	3193.00
	4	200	-8119Y	1597.00
M4	5	200	-8123B	1597.00
	6	200	-8128G	1597.00
	8	200	-8133M	1597.00
	10	200	-8138S	1700.00
	12	200	-8143Y	1751.00
	16	200	-8154J	1854.00
	20	200	-8159P	3605.00
	25	200	-8164V	4326.00
M5	30	200	-8165W	5356.00
	5	200	-8166X	1648.00
	6	200	-8170A	1648.00
	8	200	-8175F	1700.00
	10	200	-8180L	1751.00
	12	200	-8185R	1906.00
	16	200	-8196C	2627.00
	20	200	-8201H	3502.00
	25	200	-8206N	3966.00
	30	200	-8211T	6850.00
M6	35	200	-8212V	8910.00
	6	200	-8214X	2215.00
	8	200	-8219B	2215.00
	10	200	-8224G	2318.00
	12	200	-8225H	3399.00
	16	200	-8239Y	3605.00
	20	200	-8245D	4069.00
	25	200	-8250J	4893.00
	30	200	-8255P	5665.00
	35	200	-8260V	9528.00
M8	40	200	-8266A	10146.00
	45	200	-8271F	10146.00
	8	200	-8280Q	2730.00
	10	200	-8285W	2833.00
	12	200	-8291B	3090.00
	16	200	-8301M	3760.00
	20	200	-8306S	4687.00
	25	200	-8311Y	5768.00
	30	200	-8317D	6695.00
	35	200	-8322J	7880.00
M10	40	200	-8327P	8652.00
	50	200	-8338A	14369.00
	10	200	-8343F	4481.00
	12	200	-8348L	4635.00
	16	200	-8358X	5665.00
	20	200	-8364C	6798.00
	25	200	-8369H	7880.00
	40	200	-8384Z	12051.00
50	200	-8395K	20343.00	
M12	12	200	-8399P	8910.00
	16	200	-8410A	9013.00
	20	200	-8415F	11073.00
	25	200	-8420L	12309.00
	30	200	-8425R	17356.00

ISO Metric - Self Colour

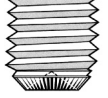

Size	L	Box Qty	Order Code QFT-602	Price/100 TB
M2	3	200	-3077D	340.00
	4	200	-3080G	340.00
	5	200	-3083K	340.00
M3	6	200	-3088Q	340.00
	8	200	-3093W	340.00
	10	200	-3099B	438.00
	12	200	-3104G	438.00
	16	200	-3114S	464.00
M4	4	200	-3119Y	443.00
	5	200	-3123B	443.00
	6	200	-3128G	443.00
	8	200	-3133M	443.00
	10	200	-3138S	443.00
	12	200	-3143Y	443.00
M4	16	200	-3154J	443.00
	20	200	-3159P	443.00
	25	200	-3164V	454.00
	5	200	-3166X	454.00
	6	200	-3170A	454.00
M5	8	200	-3175F	454.00
	10	200	-3180L	454.00
	12	200	-3185R	454.00
	15	200	-3190X	464.00
	16	200	-3196C	464.00
	20	200	-3201H	464.00
M6	25	200	-3206N	474.00
	30	200	-3211T	979.00
	6	200	-3214X	567.00
	8	200	-3219B	567.00
	10	200	-3224G	567.00
	12	200	-3229M	567.00
	15	200	-3234S	927.00
	16	200	-3239Y	510.00
	20	200	-3245D	515.00
	25	200	-3250J	531.00
M8	30	200	-3255P	541.00
	40	200	-3266A	773.00
	45	200	-3271F	979.00
	50	200	-3275K	2575.00
	8	200	-3280Q	680.00
	10	200	-3285W	680.00
	12	200	-3291B	680.00
	15	200	-3296G	680.00
	16	200	-3301M	680.00
	20	200	-3306S	680.00
M8	25	200	-3311Y	747.00
	30	200	-3317D	752.00
	35	200	-3322J	763.00
	40	200	-3327P	1236.00
	50	200	-3338A	2009.00
	10	200	-3343F	773.00
M10	12	200	-3348L	773.00
	15	200	-3353R	876.00
	16	200	-3358X	979.00
	20	200	-3364C	979.00
	25	200	-3369H	1133.00
	30	200	-3374N	1236.00
M12	40	200	-3384Z	2936.00
	50	200	-3395K	3348.00
	12	200	-3399P	773.00
	16	200	-3410A	773.00
	20	200	-3415F	773.00
M16	25	200	-3420L	835.00
	30	200	-3425R	850.00
	16	200	-3461D	1339.00
	20	200	-3466J	1339.00
	30	200	-3476V	2215.00

FASTENERS



QUALFAST Socket Set Screws - Inch

High tensile alloy steel. Grade 14.9. BS 2470.

No. 4 to 5/8"

UNC - Self Colour

Thread Size	S (hex)
No. 4	.050"
No. 6	1/16"
No. 8	5/64"
No. 10	3/32"
1/4"	1/8"
5/16"	5/32"
3/8"	3/16"
1/2"	1/4"
5/8"	5/16"



Standard (Self-Colour)

Size	L	Box Qty	Order Code QFT-603	Price/100 TB
4	1/8"		-3708J	2509.00
	3/16"		-3709K	2618.00
	1/4"		-3712N	2950.00
	5/16"		-3713P	2684.00
6	1/2"		-3716S	3149.00
	1/8"		-3728E	3089.00
	3/16"		-3731H	4119.00
	1/4"		-3734L	4120.00
8	1/2"		-3736N	4366.00
	1/8"		-3748A	2891.00
	3/16"		-3749B	2176.00
	1/4"		-3753F	2165.00
10	3/8"		-3762Q	2907.00
	1/2"		-3764S	4733.00
	1/4"		-3774C	1836.00
	3/8"		-3780J	1849.00
10	1/2"		-3783M	3618.00
	1"		-3790V	5614.00

Knurled Cup - BS EN 4168

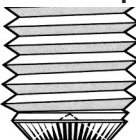

For quick and permanent location of pulleys, collars and gears on shafts. Will hold fast even in poorly tapped holes. Interrupted profile of clamping face resists loosening due to vibration. Sizes above 1/4" are generally counterbored to provide maximum clamping efficiency.

Size	L	Box Qty	Order Code QFT-603	Price/100 TB
1/4"	1/4"		-3792X	2678.00
	5/16"		-3797B	3923.00
	3/8"		-3800E	1484.00
	1/2"		-3805K	1625.00
	5/8"		-3810Q	4433.00
	3/4"		-3813T	4208.00
	1"		-3816X	4433.00
	3/8"		-3827H	1830.00
5/16"	1/4"		-3825F	2884.00
	5/16"		-3826G	2884.00
	1/2"		-3833P	2069.00
	3/4"		-3839W	8910.00
	1"		-3842Z	5202.00
	3/8"		-3852J	1674.00
	5/8"		-3859R	3553.00
	1/2"		-3857P	3089.00
3/8"	3/4"		-3862V	3075.00
	1"		-3868A	6386.00
	1 1/4"		-3872E	7468.00
	1 1/2"		-3874G	16995.00
	2"		-3878M	28325.00
	1/2"		-3888X	5305.00
	5/8"		-3890Z	7622.00
	1"		-3897F	19055.00
1/2"	1 1/4"		-3901K	20085.00
	1 1/2"		-3902L	52530.00
	3/4"		-3909T	33990.00
	1"		-3910V	46350.00

No. 10 to 5/8"

UNF - Self Colour

Size	L	Box Qty	Order Code QFT-603	Price/100 TB
10	1/4"		-4020X	2059.00
	5/16"		-4022Z	2509.00
	3/8"		-4024B	1251.00
	1/2"		-4030G	1748.00
	3/4"		-4032J	2450.00
	1"		-4034L	5665.00
	1/4"		-4037P	2045.00
	5/16"		-4040S	1371.00
1/4"	3/8"		-4042V	2559.00
	1/2"		-4049B	1928.00
	5/8"		-4050C	6953.00
	3/4"		-4051D	5202.00
	1"		-4054G	5820.00
	1/4"		-4056J	8034.00
	3/8"		-4059M	1655.00
	1/2"		-4063R	2822.00
5/16"	5/8"		-4065T	6026.00
	3/4"		-4066V	4907.00
	1"		-4068X	10249.00
	3/8"		-4074C	2621.00
	1/2"		-4077F	3045.00
	5/8"		-4078G	6489.00
	3/4"		-4081K	4353.00
	1"		-4083M	5075.00
3/8"	1 1/4"		-4084N	7983.00
	1/2"		-4087R	11588.00
	5/8"		-4088S	11124.00
	3/4"		-4089T	21115.00
1/2"	1"		-4093Y	10918.00
	5/8"		-4100F	78795.00

Hexagon Ball Driver Sets

Metric 6 Piece Set Contents:

1.5, 2, 2.5, 3, 4 and 5mm.

Metric 9 Piece Set Contents:

1.5, 2, 2.5, 3, 4, 5, 6, 8 and 10mm.

Inch 8 Piece Set Contents:

1/16", 5/64", 1/8", 9/64", 5/32", 3/16", 1/4" and 3/8".



6 PIECES

METRIC



Number of Pieces	Weight each	Order Code KEN-602	Price/1 TB
6	170g	-2560K	567.00



9 PIECES

METRIC



Number of Pieces	Weight each	Order Code KEN-602	Price/1 TB
9	640g	-2590K	979.00



8 PIECES

INCH



Number of Pieces	Weight each	Order Code KEN-602	Price/1 TB
8	480g	-2640K	876.00

PRODUCTS ARE ONLY AVAILABLE VIA YOUR DISTRIBUTOR

GROUP 604 SOCKET HEAD COUNTERSUNK SCREWS

QUALFAST Socket Head Countersunk Screws

High Grade Alloy Steel to **BS EN ISO 898/1 Grade 10.9**. Suitable for all high tensile applications. Maximum operating temperature (unplated): 300°C. For applications that require a flush finished surface. Precisely controlled countersink angle allows maximum flushness and sidewall contact.

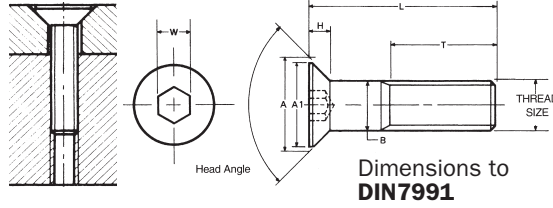

A = Maximum theoretical sharp corner.
Inclined angle under head:
 Up to M20 = 90°
 Above M20 = 60°



Thread Size	Dimensions (mm)		
	A	H	W (hex)
M2.5	5.00	1.00	1.5
M3	6.72	1.86	2.0
M4	8.96	2.48	2.5
M5	11.20	3.10	3.0
M6	13.44	3.72	4.0
M8	17.92	4.96	5.0

Size		ISO Metric - Self Colour		ISO Metric BZP		ISO Metric A2 Stainless		
		Order Code QFT-604	Price/100 TB	Order Code QFT-604	Price/100 TB	Order Code QFT-606	Price/100 TB	
M2.5	5	200	-	-	-	-	-	
	6	200	-	-	-	-	-	
	12	200	-	-	-	-	-	
	6	200	-2020A	1186.00	-0400A	979.00	-7010A	1286.00
	8	200	-2021B	988.00	-	-	-7011B	1183.00
	10	200	-2022C	992.00	-0400C	979.00	-7014E	1234.00
	12	200	-2023D	1174.00	-0400D	1133.00	-7020A	2371.00
	15	200	-2024E	1444.00	-	-	-7021B	1977.00
	16	200	-2025F	2133.00	-0400G	1236.00	-7022C	1984.00
	18	200	-2026G	3979.00	-	-	-7023D	2347.00
M3	20	200	-2027H	2272.00	-	-	-	-
	25	200	-2028J	3502.00	-	-	-7027H	4543.00
	30	200	-2029K	5114.00	-	-	-7028J	7004.00
	6	200	-	-	-0403B	1339.00	-7029K	10249.00
	8	200	-2030L	804.00	-0403C	979.00	-7030A	1854.00
	10	200	-2031M	809.00	-0403D	1030.00	-7030L	1608.00
	12	200	-2032N	874.00	-0403R	1236.00	-7031M	1617.00
	15	200	-2033P	1444.00	-	-	-7032N	1747.00
	16	200	-2034Q	976.00	-0403E	1339.00	-	-
	18	200	-2035R	2048.00	-0403F	1545.00	-7033P	1951.00
M4	20	200	-2036S	1211.00	-0404E	1339.00	-7034Q	2420.00
	25	200	-2037T	1845.00	-0405F	1545.00	-7037T	3690.00
	30	200	-2038V	2559.00	-0406G	1751.00	-7038V	5117.00
	35	200	-2039W	5023.00	-	-	-7039W	10094.00
	40	200	-2040X	4280.00	-	-	-7040X	8601.00
	45	200	-2040Z	6283.00	-	-	-	-
	50	200	-2041D	6953.00	-	-	-	-
	8	200	-2041Y	886.00	-0599Z	1339.00	-7042Y	1772.00
	10	200	-2042Z	829.00	-0600A	1442.00	-7043Z	1657.00
	12	200	-2044A	862.00	-0601B	1545.00	-7044A	1723.00
M5	14	200	-2044W	2126.00	-	-	-	-
	15	200	-2045B	1398.00	-0603D	1751.00	-7046C	1854.00
	16	200	-2046C	927.00	-	-	-	-
	18	200	-2047D	2262.00	-0604E	1854.00	-7048E	2133.00
	20	200	-2048E	1067.00	-0605F	1957.00	-7049F	2199.00
	25	200	-2049F	1100.00	-0606G	2163.00	-7050G	3788.00
	30	200	-2050G	1895.00	-	-	-7051H	5717.00
	35	200	-2051H	2841.00	-0607H	2575.00	-7052J	6335.00
	40	200	-2052J	3161.00	-	-	-	-
	45	200	-2053K	3652.00	-0608J	3193.00	-7054L	7468.00
M6	50	200	-2054L	3723.00	-0609K	3502.00	-7055M	12051.00
	60	200	-2054N	6026.00	-	-	-7055T	7880.00
	8	200	-2055M	1563.00	-	-	-7056N	1895.00
	10	200	-2056N	948.00	-0700A	1545.00	-	-
	12	200	-2057P	899.00	-0700B	1700.00	-7057P	1797.00
	14	200	-2058M	1677.00	-	-	-	-
	15	200	-2058Q	1181.00	-0703D	1803.00	-7059R	1805.00
	16	200	-2059R	903.00	-	-	-	-
	18	200	-2060S	1938.00	-0705F	1906.00	-7061T	1993.00
	20	200	-2061T	997.00	-0706G	2009.00	-7062V	2337.00
M8	25	200	-2062V	1169.00	-0707H	2369.00	-7063W	3591.00
	30	200	-2063W	1796.00	-0708J	2678.00	-7064X	4319.00
	35	200	-2064X	2160.00	-0709K	2781.00	-7065Y	4477.00
	40	200	-2065Y	2239.00	-0710L	2884.00	-7066Z	6283.00
	45	200	-2066Z	3123.00	-0711M	2987.00	-7068A	6438.00
	50	200	-2068A	3211.00	-	-	-	-
	55	200	-2068F	4952.00	-0712N	3193.00	-7069B	7056.00
	60	200	-2068N	3505.00	-	-	-7070C	16686.00
	70	200	-2068Q	8343.00	-	-	-7070P	20549.00
	75	200	-2068X	7828.00	-	-	-	-
M8	10	200	-2069B	1915.00	-0800A	1803.00	-	-
	12	200	-2070C	1681.00	-	-	-	-
	15	200	-2071D	3572.00	-0801B	1906.00	-7072E	2453.00
	16	200	-2072E	1226.00	-	-	-	-
	18	200	-2073F	3303.00	-0802C	2009.00	-7074G	2585.00
	20	200	-2074G	1292.00	-0803D	2163.00	-7075H	2829.00
	25	200	-2075H	1415.00	-0804E	2369.00	-7076J	4083.00
	30	200	-2076J	2042.00	-0805F	2575.00	-7077K	4986.00
	35	200	-2077K	2493.00	-0806G	2730.00	-7078L	5356.00
	40	200	-2078L	2665.00	-0807H	3039.00	-7079M	7416.00
45	200	-2079M	3702.00	-0808J	3193.00	-7080N	8189.00	
50	200	-2080N	4084.00	-	-	-	-	

CONTINUED ON NEXT PAGE...

FASTENERS

SOCKET HEAD COUNTERSUNK SCREWS

QUALFAST Socket Head Countersunk Screws

High Grade Alloy Steel to **BS EN ISO 898/1 Grade 10.9**. Suitable for all high tensile applications.
Maximum operating temperature (unplated): 300°C. For applications that require a flush finished surface. Precisely controlled countersink angle allows maximum flushness and sidewall contact.

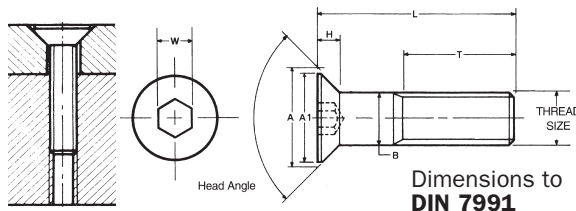

A = Maximum theoretical sharp corner.
Inclined angle under head:
Up to M20 = 90°
Above M20 = 60°



Thread Size	Dimensions (mm)		
	A	H	W (hex)
M8	17.92	4.96	5.0
M10	22.40	6.20	6.0
M12	26.88	7.44	8.0
M14	26.00	9.95	10.0
M16	33.60	8.80	10.0
M20	40.32	9.48	12.0

Size	L	Box Qty	ISO Metric - Self Colour		ISO Metric BZP		ISO Metric A2 Stainless	
			Order Code QFT-604	Price/100 TB	Order Code QFT-604	Price/100 TB	Order Code QFT-606	Price/100 TB
M8 con't	55	100	-2081P	6180.00	-	-	-	-
	60	100	-2082Q	5768.00	-0810L	3605.00	-7082Q	11485.00
	65	100	-	-	-	-	-7083R	13648.00
	70	100	-2083R	7571.00	-0812M	4635.00	-7084S	15141.00
	80	50	-2083V	10352.00	-0814P	4893.00	-7085G	20703.00
	90	10	-2083T	12360.00	-	-	-	-
	95	10	-2083W	13493.00	-	-	-	-
	100	10	-2083Z	15296.00	-	-	-7086H	30540.00
	12	200	-2084S	4012.00	-	-	-	-
	15	200	-2085T	5562.00	-	-	-	-
M10	16	200	-2086V	2723.00	-0899B	2163.00	-7086V	5459.00
	18	200	-	-	-	-	-	-
	20	200	-2088X	2395.00	-0900A	2369.00	-7087W	4790.00
	25	200	-2089Y	1751.00	-0901B	2472.00	-7089Y	3501.00
	30	200	-2090Z	2035.00	-0902C	2678.00	-7090Z	4068.00
	35	200	-2092A	2530.00	-0903D	2884.00	-7092A	5059.00
	40	100	-2093B	2567.00	-0904E	3193.00	-7093B	5134.00
	45	100	-2094C	8498.00	-0905F	3605.00	-7093C	16995.00
	50	100	-2095D	3834.00	-0906G	3708.00	-7094C	7674.00
	55	100	-2096E	6489.00	-0907H	4069.00	-	-
M12	60	100	-2097F	6077.00	-0908J	4223.00	-7095D	12154.00
	65	50	-2098A	14832.00	-	-	-	-
	70	50	-2098G	7210.00	-0910L	5665.00	-	-
	75	50	-2099B	15038.00	-0911M	7725.00	-	-
	80	50	-2099H	9322.00	-	-	-7097F	18643.00
	90	50	-2100J	10352.00	-	-	-	-
	100	50	-2101K	12360.00	-	-	-	-
	110	50	-2101L	21270.00	-	-	-	-
	120	50	-2101M	24514.00	-	-	-	-
	16	100	-	-	-	-	-	-
M16	20	100	-2102L	5202.00	-1000A	2500.00	-7102L	10050.00
	25	100	-2103M	3346.00	-1001B	5750.00	-7103M	6500.00
	30	100	-2104N	3437.00	-1002C	4900.00	-7104N	6700.00
	35	100	-2105P	3617.00	-1003D	6900.00	-7105P	7050.00
	40	100	-2106Q	3932.00	-1004E	7050.00	-7106Q	7650.00
	45	50	-2107R	4291.00	-1005F	6950.00	-7107R	8350.00
	50	50	-2108S	5562.00	-1006G	7000.00	-7108S	10750.00
	55	50	-2109T	8755.00	-	-	-	-
	60	50	-2110V	8395.00	-1008J	8000.00	-7110V	16300.00
	65	50	-2111D	11691.00	-	-	-	-
M20	70	50	-2111W	11485.00	-	-	-	-
	75	50	-2112F	16120.00	-	-	-7112L	31300.00
	80	50	-2112X	13905.00	-1012P	8500.00	-7112X	27000.00
	90	50	-2113Y	20446.00	-1014R	9500.00	-7113Y	39700.00
	100	50	-2114Z	20446.00	-	-	-	-
	120	50	-2115R	36617.00	-	-	-	-
	30	50	-2118C	11000.00	-1230G	5500.00	-	-
	35	50	-2119D	7050.00	-	-	-	-
	40	50	-2120E	7100.00	-1232J	5750.00	-	-
	45	50	-2121F	11550.00	-1232K	7999.00	-	-
M20	50	50	-2122G	11200.00	-1233K	8500.00	-	-
	55	25	-2123H	15100.00	-	-	-	-
	60	25	-2124J	8950.00	-1234L	9000.00	-	-
	70	25	-2125K	15050.00	-	-	-	-
	75	25	-2126A	22000.00	-	-	-	-
	80	25	-2126L	24300.00	-	-	-	-
	90	25	-2127M	34300.00	-	-	-	-
	100	25	-2128N	48550.00	-	-	-	-
	120	25	-2130Q	53750.00	-	-	-	-
	40	25	-2137Y	21200.00	-	-	-	-
45	25	-2138Z	29950.00	-	-	-	-	
50	25	-2139A	21200.00	-	-	-	-	
55	25	-2141F	23200.00	-	-	-	-	
60	25	-2142C	22950.00	-	-	-	-	
70	25	-2143D	30800.00	-	-	-	-	
80	25	-2144E	30450.00	-	-	-	-	
90	25	-2145F	37100.00	-	-	-	-	
100	25	-2146G	40850.00	-	-	-	-	

PRODUCTS ARE ONLY AVAILABLE VIA YOUR DISTRIBUTOR

FASTENERS

GROUP 604 SOCKET HEAD COUNTERSUNK SCREWS

QUALFAST Socket Head Countersunk Screws - Inch - Self Colour



High Grade Alloy Steel to **BS EN ISO 898/1 Grade 10.9**. Suitable for all high tensile applications. Maximum operating temperature (unplated): 300°C. For applications that require a flush finished surface. Precisely controlled countersink angle allows maximum flushness and sidewall contact.

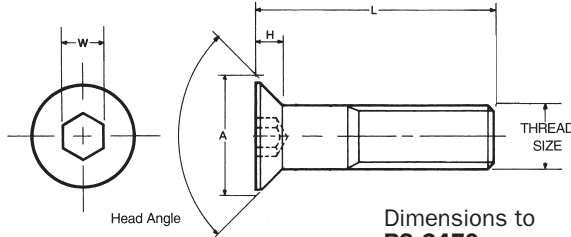
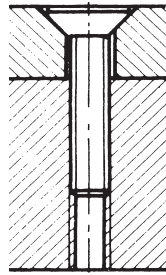

A = Maximum theoretical sharp corner. Inclined angle under head: Up to M20 = 91°/89°

UNC, UNF

Thread Size	Dimensions (mm)		
	A	H	W (hex)
4	.255	.083	1/16"
6	.307	.097	5/64"
8	.359	.112	3/32"
10	.411	.127	1/8"
1/4"	.531	.161	5/32"
5/16"	.656	.198	3/16"
3/8"	.781	.234	7/32"
1/2"	.938	.251	5/16"



Standard (Self-Colour)

Size	L	Order Code QFT-605	Price/100 TB
4	1/4"	-2204E	2933.00
	3/8"	-2205F	2991.00
	100 1/2"	-2206G	4494.00
Box	3/4"	-2207H	4801.00
6	1/4"	-2213P	3897.00
	3/8"	-2214Q	3290.00
	100 1/2"	-2215R	2573.00
Box	3/4"	-2216S	4934.00
8	3/8"	-2218V	2231.00
	1/2"	-2219W	2305.00
	100 5/8"	-2220G	9476.00
Box	3/4"	-2220X	5562.00
10	1"	-2221Y	4365.00
	3/8"	-2224A	2670.00
	1/2"	-2225B	2651.00
100 5/8"	-2226C	3017.00	
Box	3/4"	-2227D	3285.00
100	1"	-2229F	1860.00
	1/4"	-2239R	7107.00
	3/8"	-2231H	4973.00
100 1/2"	-2232J	2534.00	
1/4"	5/8"	-2233K	2323.00
	3/4"	-2234L	2563.00
	Box 1"	-2235M	2904.00
100	1 1/4"	-2236N	4276.00
	1 1/2"	-2237P	3992.00
	1/2"	-2241T	3886.00
5/8"	-2242V	3559.00	
3/4"	-2243W	3423.00	
5/16"	1"	-2245Y	3909.00
100 1 1/4"	-2246Z	8189.00	
Box 1 1/2"	-2248A	10815.00	
2"	2"	-2250C	10815.00
	2 1/2"	-2252E	11639.00
	3/4"	-2254G	3939.00
1"	-2256J	4139.00	
3/8"	1 1/4"	-2257K	4700.00
100 1 1/2"	-2258L	5408.00	
Box 2"	-2260A	11794.00	
100 2 1/2"	-2261P	31055.00	
100	3/4"	-2266V	17150.00
	Box 1/2"	-2268X	9425.00
	1"	-2267W	8137.00
1/2"	1 1/2"	-2269Y	10352.00
	1 3/4"	-2270B	26265.00
	50 2"	-2270Y	14781.00
Box 3"	-2271L	22712.00	

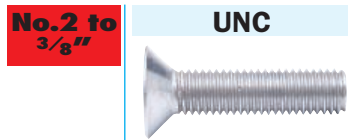

A2 Stainless Steel

Size	L	Order Code QFT-606	Price/100 TB
2	1/4"	-7500A	8498.00
4	1/4"	-7530A	5871.00
	100 3/8"	-7531B	6026.00
Box	1/2"	-7532C	9013.00
6	1/4"	-7570A	7828.00
	100 1/2"	-7572C	5146.00
Box	5/8"	-7573D	5408.00
8	3/8"	-7591B	4461.00
	1/2"	-7592C	4609.00
	3/4"	-7593D	11073.00
100 1"	-7594E	8755.00	
Box	1 1/4"	-7595F	10043.00
10	3/8"	-7610A	5356.00
	1/2"	-7611B	5305.00
	100 3/4"	-7612C	6592.00
Box	1 1/2"	-7614E	10043.00
1/4"	1/2"	-7630A	5068.00
	3/4"	-7632C	5125.00
	100 1"	-7633D	5820.00
Box 1 1/2"	-7634E	7983.00	
5/16"	3/4"	-7641B	6850.00
	100 1"	-7642C	7828.00
	3/8"	3/4"	-7651B
100 1"	-7652C	8292.00	
Box 1 1/2"	-7653D	10764.00	

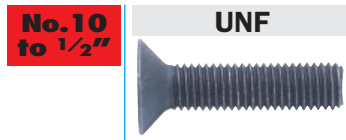

Standard (Self-Colour)

Size	L	Order Code QFT-605	Price/100 TB
10	3/8"	-2382C	2300.00
	1/2"	-2383D	2090.00
100	5/8"	-2384E	2973.00
	3/4"	-2385F	3377.00
Box	1"	-2386G	3783.00
1/4"	1/2"	-2390L	4388.00
	5/8"	-2391M	3960.00
100	3/4"	-2392N	3339.00
	1"	-2393P	3782.00
Box	1 1/2"	-2394Q	6953.00
5/16"	3/4"	-2397T	4023.00
	1"	-2399W	4627.00
100 1 1/4"	-2400X	7571.00	
Box 1 1/2"	-2401Y	7210.00	
3/8"	3/4"	-2404A	4753.00
	1"	-2405B	7416.00
100 1 1/4"	-2406C	20085.00	
Box 1 1/2"	-2407D	8652.00	
1/2"	1"	-2411H	17768.00
	1 1/4"	-2412J	21939.00
100 1 1/2"	-2413K	13030.00	
Box 2"	-2415M	41664.00	

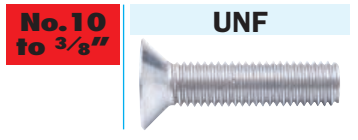

A2 Stainless Steel

Size	L	Order Code QFT-606	Price/100 TB
10	3/8"	-7700A	4600.00
	1/2"	-7701B	4179.00
100 3/4"	-7702C	6798.00	
Box	1"	-7703D	7571.00
1/4"	1/2"	-7705F	8807.00
	100 3/4"	-7706G	6695.00
Box	1 1/2"	-7708J	13905.00
3/8"	1 1/2"	-7715R	17304.00



Group 615

KENNEDY Ball Driver L-Wrenches

Manufactured from fully hardened carbon steel. A quality ductile key with precision cut ends and accurate AF dimensional to ensure maximum socket contact. Ball end allows up to 30° work offset. Long arm end is ball drive and short arm end plain. Black oxidised finish.

Metric 7 Piece Set Contents:

1.5, 2, 2.5, 3, 4, 5 and 6mm.

Metric 9 Piece Set Contents:

1.5, 2, 2.5, 3, 4, 5, 6, 8 and 10mm.



Supplied in a plastic storage clip.

METRIC HEXAGON

Number of Pieces	Weight each	Order Code KEN-602	Price/1 TB
7	110g	-4570K	350.00
9	350g	-5500K	564.00

Inch 7 Piece Set Contents:

5/64", 3/32", 7/64", 1/8", 9/64", 5/32" and 3/16".

Inch 9 Piece Set Contents:

5/64", 3/32", 1/8", 5/32", 3/16", 7/32", 1/4", 5/16" and 3/8".



Supplied in a plastic storage clip.

INCH HEXAGON

Number of Pieces	Weight each	Order Code KEN-602	Price/1 TB
7	80g	-5580K	350.00
9	370g	-5730K	564.00

FASTENERS

SOCKET HEAD BUTTON SCREWS



Socket Head Button Screws

High Grade Alloy Steel to **BS EN ISO 898/1 Grade 10.9**. For high tensile applications. Maximum operating temperature (unplated): 300°C. For materials that are too thin to countersink. Low head profile for a smooth finished appearance. Also suitable for non-critical loading requiring heat treated fasteners.

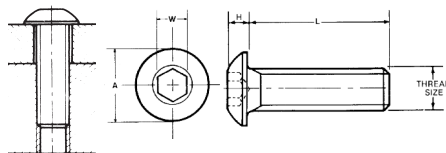

Dimensions to **BS EN ISO 7380**

Thread Size	Dimensions (mm)		
	A	H	W (hex)
M3	5.50	1.5	2.0
M4	7.60	2.2	2.5
M5	9.50	2.8	3.0
M6	10.50	3.3	4.0
M8	14.00	4.4	5.0
M10	17.30	5.4	6.0
M12	20.70	6.4	8.0



M3 to M12		ISO Metric - Self Colour		ISO Metric BZP		ISO Metric A2 Stainless		
Size	L	Box Qty	Standard (Self-Colour)		Bright Zinc Plated (BZP)		A2 Stainless Steel	
			Order Code QFT-604	Price/100 TB	Order Code QFT-604	Price/100 TB	Order Code QFT-606	Price/100 TB
M3	5	200	-0198X	464.00	-4009Z	2090.00	-	-
	6	200	-0200A	464.00	-4100A	1313.00	-5529M	2100.00
	8	200	-0201B	464.00	-4100C	908.00	-5529T	1452.00
	10	200	-0202C	464.00	-4100E	1159.00	-5530A	1854.00
	12	200	-0203D	464.00	-4100G	1302.00	-5530J	2083.00
	16	200	-0206G	464.00	-	-	-5531K	2780.00
	20	200	-0206T	1236.00	-	-	-5531P	3011.00
	25	200	-0207B	1339.00	-	-	-5531T	3432.00
	30	200	-0207D	4275.00	-	-	-5531W	10815.00
	6	200	-0207F	515.00	-4100X	1727.00	-5532D	2763.00
8	200	-0207H	515.00	-4100Z	851.00	-5532T	1361.00	
10	200	-0208J	515.00	-4101B	866.00	-5532Y	1385.00	
12	200	-0209K	515.00	-4102C	906.00	-5533G	1449.00	
15	200	-0211M	515.00	-	-	-	-	
16	200	-0212N	515.00	-4103D	1016.00	-5533R	1625.00	
20	200	-0212T	515.00	-4104E	1203.00	-5534B	1924.00	
25	200	-0212V	979.00	-4106G	638.00	-5534G	1020.00	
30	200	-0212X	876.00	-4107H	1100.00	-5534K	1759.00	
35	200	-0212Y	1005.00	-	-	-	-	
40	200	-0212Z	1005.00	-4109K	1997.00	-5534R	3193.00	
6	200	-0213E	979.00	-	-	-	-	
8	200	-0213L	670.00	-4196F	1730.00	-5535G	2767.00	
10	200	-0213P	670.00	-4200A	1002.00	-5535H	1602.00	
12	200	-0214Q	670.00	-4201B	971.00	-5535R	1553.00	
15	200	-0216S	773.00	-	-	-	-	
16	200	-0217T	670.00	-4202C	1264.00	-5535Y	2023.00	
18	200	-0217W	670.00	-	-	-	-	
20	200	-0219W	670.00	-4203D	1663.00	-5536G	2660.00	
22	200	-0220X	670.00	-	-	-5536R	2548.00	
25	200	-0221Y	670.00	-4204E	1593.00	-5536Y	4263.00	
30	200	-0222Q	670.00	-4205F	2665.00	-	-	
35	200	-0222T	773.00	-	-	-5537B	5202.00	
40	200	-0223A	979.00	-	-	-5537H	4600.00	
50	200	-0223C	979.00	-	-	-5537T	7622.00	
8	200	-0223D	747.00	-4298Z	3464.00	-5537X	5562.00	
10	200	-0224A	747.00	-4300A	1245.00	-5538A	1990.00	
12	200	-0225B	747.00	-4301B	1062.00	-5538F	1700.00	
15	200	-0227D	747.00	-	-	-	-	
16	200	-0228E	747.00	-4302C	1148.00	-5538R	1836.00	
18	200	-0229F	747.00	-	-	-	-	
20	200	-0230G	747.00	-4303D	1229.00	-5539D	1966.00	
25	200	-0232J	773.00	-4304E	1532.00	-5539K	2452.00	
30	200	-0233K	773.00	-4305F	1933.00	-5539T	3093.00	
35	200	-0233M	1339.00	-4306G	3039.00	-5539V	4862.00	
40	200	-0233Q	1442.00	-4307H	3271.00	-5539W	5253.00	
45	200	-0233T	1442.00	-4308J	4008.00	-	-	
50	200	-0233X	1442.00	-4309K	2375.00	-5539Z	3799.00	
60	200	-	-	-4311M	4326.00	-	-	
70	200	-	-	-4315R	6489.00	-	-	
10	200	-0234L	1442.00	-4400A	2936.00	-5543J	3035.00	
12	200	-0235M	1545.00	-	-	-5544A	2530.00	
16	200	-0238O	1545.00	-4401B	2421.00	-5544K	2653.00	
20	200	-0240S	1545.00	-4402C	2472.00	-5545A	2498.00	
25	200	-0242V	1545.00	-4403D	2421.00	-5545R	2903.00	
30	200	-0243W	1545.00	-4404E	2085.00	-5546B	3336.00	
35	200	-0244X	1545.00	-4405F	2834.00	-5546K	4534.00	
40	200	-0245Y	1648.00	-4406G	3069.00	-5547C	4909.00	
45	200	-0246B	1751.00	-	-	-5548D	7468.00	
50	200	-0246H	1854.00	-4408J	5051.00	-5549E	8086.00	
60	200	-0246Z	2163.00	-4409K	7107.00	-5551G	11382.00	
70	200	-	-	-	-	-5552H	21012.00	
80	200	-	-	-	-	-5553J	25235.00	
12	200	-	-	-	-	-5586M	5408.00	
16	200	-0249B	1648.00	-	-	-5587N	5408.00	
20	200	-0251D	1751.00	-4502C	2358.00	-5588P	3772.00	
25	200	-0253F	1854.00	-4503D	2825.00	-5590A	4519.00	
30	200	-0254G	1957.00	-4504E	2964.00	-5591B	4741.00	
35	200	-0255H	1957.00	-4505G	3970.00	-5592C	6386.00	
40	100	-0256J	1957.00	-4506H	3874.00	-5593D	6232.00	
45	100	-0257B	1957.00	-	-	-	-	
50	100	-0257L	2163.00	-	-	-5594E	17304.00	
60	100	-0257N	2575.00	-4509L	14369.00	-	-	
70	100	-0257T	3348.00	-	-	-	-	
16	100	-0259M	2678.00	-	-	-	-	
20	100	-0261P	2575.00	-4602C	7880.00	-5598W	12566.00	
25	100	-0263R	2575.00	-4603D	5614.00	-5599X	8961.00	
30	100	-0264S	2575.00	-4604E	7210.00	-5600A	11485.00	
35	100	-0265T	3605.00	-4605F	8189.00	-	-	
40	50	-0266V	3502.00	-4606G	8086.00	-5602C	12875.00	
45	50	-	-	-4607H	9270.00	-	-	
50	50	-0268X	24720.00	-4608J	11639.00	-5603D	18643.00	

PRODUCTS ARE ONLY AVAILABLE VIA YOUR DISTRIBUTOR

QUALFAST Socket Head Button Screws

High Grade Alloy Steel to **BS EN ISO 898/1 Grade 10.9**. Suitable for all high tensile applications. Maximum operating temperature (unplated): 300°C. For materials that are too thin to countersink. Low head profile for a smooth finished appearance. Also suitable for non-critical loading requiring heat treated fasteners.

Thread Size	Dimensions (mm)		
	A	H	W (hex)
UNC/UNF			
6	.262	.073	5/64
8	.312	.087	3/32
10	.361	.101	1/8
1/4	.437	.132	5/32
5/16	.547	.166	3/16

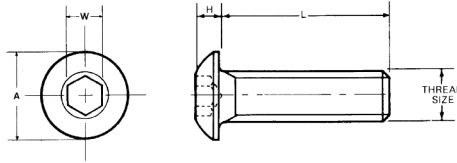
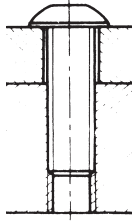

UNC/UNF Dimensions to **ANSI B 18.3**
BSW/BA Dimensions to **BS 2470**

No.10 to 5/16" **UNF - Self Colour**



Standard (Self-Colour)

Size	L	Box Qty	Order Code	Price/100 TB
10	1/4"	100	-0350A	3350.00
	3/8"	100	-0351B	2358.00
	1/2"	100	-0352C	2153.00
	5/8"	100	-0353D	2992.00
	3/4"	100	-0354E	2924.00
1"	100	-0355F	3799.00	
1/4"	1/2"	100	-0357H	3046.00
	3/4"	100	-0359K	3450.00
	1"	100	-0361L	5059.00
5/16"	1/2"	200	-0362M	19828.00
	5/8"	200	-0363M	11845.00
	3/4"	200	-0364N	7725.00

No.4 to 3/8" **UNC - Self Colour**



Standard (Self-Colour)

Size	L	Box Qty	Order Code	Price/100 TB
4	1/4"	100	-0293D	8652.00
	3/8"	100	-0294E	9476.00
6	1/4"	100	-0295F	2408.00
	3/8"	100	-0296G	2379.00
1/2"	100	-0297H	4193.00	
	100	-0300L	2446.00	
8	1/4"	100	-0301M	2612.00
	1/2"	100	-0302N	2690.00
3/4"	100	-0303Y	3013.00	
	100	-0305R	8755.00	
10	3/8"	100	-0306S	2236.00
	1/2"	100	-0307T	2168.00
3/4"	100	-0309W	3939.00	
	100	-0311Y	6283.00	
1/4"	3/8"	100	-0313Z	2060.00
	1/2"	100	-0314A	2060.00
5/8"	100	-0315B	2148.00	
	3/4"	100	-0316C	2207.00
1"	100	-0318B	2835.00	
1/2"	100	-0319E	3402.00	
5/16"	5/8"	100	-0320G	5614.00
	3/4"	100	-0321H	4084.00
1"	100	-0322J	7004.00	
3/8"	1/2"	100	-0323J	2406.00
	3/4"	100	-0324L	6695.00
1"	100	-0326N	2958.00	

Socket Head Flange Button Screws



An extra wide flange below the button head makes these fasteners ideal for fixing strips cover plates and sheet metal housings that require a greater load spread.

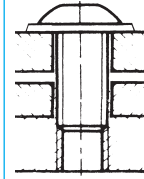

Thread Size	Dimensions (mm)		
	A	H	W (hex)
M4	9.29	2.2	2.5
M5	11.40	2.8	3.0
M6	13.59	3.3	4.0
M8	17.00	4.4	5.0
M10	20.80	5.4	6.0

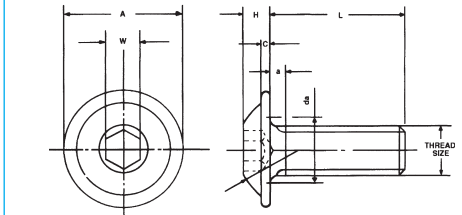

Dimensions to **BS EN ISO 898/1**
Grade 10.9 DIN 7380

M3 to M10 **ISO Metric - Self Colour**



Standard (Self-Colour)

Size	L	Box Qty	Order Code	Price/100 TB
M3	8	200	-3001B	907.00
	10	200	-3002C	1405.00
	12	200	-3003D	1366.00
1/4"	6	200	-3008J	1742.00
	8	200	-3009K	1021.00
M4	10	200	-3010L	921.00
	12	200	-3011M	933.00
	16	200	-3013P	1372.00
8	200	-3019W	1480.00	
	10	200	-3020X	1032.00
	12	200	-3021Y	1277.00
M5	14	200	-3022Z	1346.00
	16	200	-3023A	1522.00
	20	200	-3024B	1578.00
	25	200	-3026D	1773.00
	8	200	-3031J	1809.00
10	200	-3032K	715.00	
	12	200	-3033L	1024.00
	16	200	-3035N	1257.00
	20	200	-3036P	1089.00
	25	200	-3038R	1846.00
M6	30	200	-3039S	2508.00
	35	200	-3040T	2595.00
	40	200	-3041V	2738.00
	50	200	-3043X	3313.00
	10	200	-3044Y	1965.00
12	200	-3045Z	2293.00	
	16	200	-3047B	1892.00
	20	200	-3048C	2188.00
	25	200	-3050E	2203.00
	30	200	-3051F	2974.00
35	200	-3052G	3268.00	
	50	200	-3055K	5356.00
	16	200	-3058N	1772.00
20	200	-3059P	2535.00	
	25	200	-3061R	2402.00
	30	200	-3062S	3634.00

QUALFAST Stainless Fastener Assortments

A2 Stainless Steel Socket Button Screw Kit
Contents: M5 x 12, M5 x 16, M5 x 20, M6 x 12, M6 x 16, M6 x 20, M6 x 25, M8 x 20, M8 x 25 and M8 x 30mm.



Type	Average Quantity	Order Code	Price/1 TB
Metric	310	-4420K	1906.00

KENNEDY Fix-it Kits

Metric Socket Screws - Button Head

Sizes: M5 x 12, 16 and 20, M6 x 12, 16, 20 and 25, M8 x 20, 25 and 30.
ISO 7380.



Average Quantity	Weight each	Order Code	Price/1 TB
310	1.80kg	-5010K	1288.00

Metric Socket Screws - BZP Button Head

Sizes: M5 x 12, 16 and 20, M6 x 12, 16, 20 and 25, M8 x 20, 25 and 30.
ISO 7380.



Average Quantity	Weight each	Order Code	Price/1 TB
310	1.80kg	-5020K	1288.00

No.4 to 5/16" **UNC Stainless A2 Steel**



A2 Stainless Steel

Size	L	Box Qty	Order Code	Price/100 TB
4	1/4"	100	-5625G	17304.00
	3/8"	100	-5626H	18952.00
	1/2"	100	-5627J	19519.00
	3/4"	100	-5628K	20343.00
6	3/8"	100	-5632T	4757.00
	1/2"	100	-5633V	8395.00
	3/4"	100	-5634W	10043.00
	1	100	-5635X	11073.00
	1/4"	100	-5640A	4890.00
8	3/8"	100	-5641B	5253.00
	1/2"	100	-5642C	5408.00
	3/4"	100	-5643D	6026.00
1"	100	-5644E	6438.00	
	1/4"	100	-5650K	8292.00
3/8"	100	-5651L	4471.00	
	1/2"	100	-5652M	4335.00
	3/4"	100	-5653N	7880.00
1"	100	-5654P	12566.00	
	1/2"	100	-5670A	4120.00
1/4"	3/4"	100	-5671B	4413.00
	1"	100	-5672C	5717.00
1/2"	100	-5680R	6850.00	
	3/4"	100	-5681S	8189.00
5/16"	1"	100	-5682T	14008.00
	1 1/2"	100	-5683V	15193.00

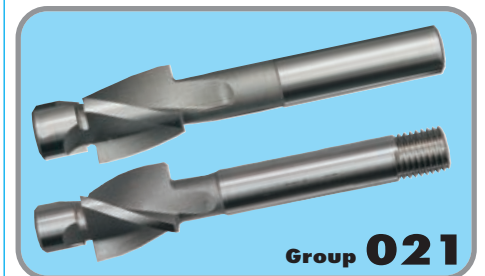

Group 021



QUALFAST *Socket Head Shoulder Screws - Metric*

High Grade Alloy Steel to **BS EN ISO 898/1 Grade 12.9**. Suitable for replacing costly components such as shafts, pivots, guides, pins, linkages and trunion mountings. Also commonly used in the die mould industry. Maximum operating temperature (unplated): 300°C.

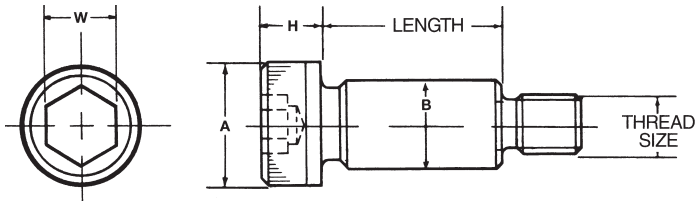

Dimensions to **ISO 7379**
Body Diameter to **h8**

Thread Size	Dimensions (mm)			
	B	A	H	W (hex)
M5	6.0	10.0	4.5	3.0
M6	8.0	13.0	5.5	4.0
M8	10.0	16.0	7.0	5.0
M10	12.0	18.0	9.0	6.0
M12	16.0	24.0	12.0	8.0
M16	20.0	30.0	14.0	10.0
M20	24.0	36.0	16.0	12.0
M24	28.0	40.0	18.0	14.0

Thread Size	Dimensions (mm)			
	B	A	H	w (hex)
3/16"	0.2480	0.375	0.188	1/8"
1/4"	0.3105	0.437	0.219	5/32"
5/16"	0.3730	0.562	0.250	3/16"
3/8"	0.4980	0.750	0.313	1/4"
1/2"	0.6230	0.875	0.375	5/16"
5/8"	0.7480	1.000	0.500	3/8"
3/4"	0.9980	1.132	0.625	1/2"

M5 to M20 **ISO Metric**

Standard (Self-Colour)

Thread Size	L	Order Code QFT-610	Price/100 TB
M5	10	-0510A	2163.00
	12	-0512C	2266.00
	15	-0515F	2730.00
	16	-0516G	2472.00
	20	-0520L	2519.00
	25	-0525R	2550.00
50 Box	30	-0530X	2936.00
	40	-0540H	3039.00
	45	-0545N	4223.00
	50	-0541J	3605.00
	60	-0547Q	6695.00
	10	-0610Y	6953.00
M6	12	-0612A	7210.00
	15	-0615F	3348.00
	16	-0616G	2936.00
	20	-0620L	3039.00
	25	-0625R	3039.00
	30	-0630X	3039.00
50 Box	35	-0635C	3605.00
	40	-0640H	3708.00

Thread Size	L	Order Code QFT-610	Price/100 TB
M5	45	-0645K	5665.00
	50	-0650J	4069.00
	60	-0651K	6695.00
	65	-0651T	7725.00
	70	-0652L	8755.00
	75	-0653A	9785.00
50 Box	80	-0653M	10815.00
	90	-0655P	11330.00
	10	-0810A	7725.00
	12	-0812C	7725.00
	15	-0815F	7725.00
	16	-0816G	3605.00
M6	20	-0820L	3605.00
	25	-0825R	3760.00
	30	-0830X	3966.00
	35	-0835C	4069.00
	40	-0840H	4378.00
	45	-0845N	4635.00
50 Box	50	-0850T	4893.00
	60	-0860V	5099.00
	65	-0865A	15450.00
	70	-0870Q	6695.00
	80	-0880B	10300.00
	90	-0890D	10815.00
M8	100	-0900F	15450.00
	120	-0920H	29819.00

Thread Size	L	Order Code QFT-610	Price/100 TB
M10	15	-1015F	8755.00
	16	-1016G	8755.00
	20	-1020L	4635.00
	25	-1025R	4738.00
	30	-1030S	5253.00
	35	-1035T	7725.00
25 Box	40	-1040H	7983.00
	45	-1045K	9785.00
	50	-1050T	10043.00
	55	-1055Y	10815.00
	60	-1060E	11073.00
	70	-1070Q	11845.00
M10	80	-1080B	12360.00
	90	-1090C	13390.00
	100	-1100Z	18540.00
	120	-1120H	21630.00
	140	-1140D	59225.00
	20	-1220V	37698.00
M12	25	-1225W	13390.00
	30	-1230X	13390.00
	35	-1235C	14678.00
	40	-1240H	9785.00
	50	-1250T	12875.00

Thread Size	L	Order Code QFT-610	Price/100 TB
M12	60	-1260E	12875.00
	70	-1270Q	14163.00
	80	-1280B	14420.00
25 Box	90	-1290L	16223.00
	100	-1300Z	16995.00
	120	-1320Z	39140.00
	140	-1340B	82400.00
M16	40	-1640H	139720.00
	50	-1650T	157745.00
	60	-1660Z	176903.00
70 Box	70	-1670Q	176800.00
	80	-1680B	342836.00
	90	-1690L	283611.00
100 Box	100	-1700Z	268985.00
	120	-1720Z	290615.00

1/4" to 5/8" **UNC**

Standard (Self-Colour)

Thread Size	L	Order Code QFT-611	Price/100 TB	
1/4"	3/8"	-4611A	10661.00	
	1"	-4614D	10918.00	
	1"	-4714D	14523.00	
5/16"	1 1/2"	-4716F	14935.00	
	25	2 1/2"	-4720K	15502.00
	Box	2 3/4"	-4721L	23330.00

Thread Size	L	Order Code QFT-611	Price/100 TB	
1"	1"	-4814D	19158.00	
	2"	-4818H	21939.00	
	2 1/2"	-4820K	23948.00	
3/8"	2 1/2"	-4821L	25750.00	
	25	3"	-4822M	27810.00
	Box	3 1/2"	-4824P	33784.00

Thread Size	L	Order Code QFT-611	Price/100 TB	
5/8"	1 1/2"	-5011A	71122.00	
	25	2 1/4"	-5014D	96923.00
	Box	2 1/2"	-5015E	85954.00
10 Box	4"	-5021L	104185.00	

Thread Size	L	Order Code QFT-611	Price/100 TB
10 Box	4"	-5021L	104185.00

KENNEDY *Fix-it Kits*

Socket Head Cap Screws

- Metric Kit Contents:**
 M5 x 16,
 M5 x 20,
 M6 x 20,
 M6 x 25,
 M8 x 25,
 M8 x 30,
 M10 x 25,
 M10 x 30,
 M12 x 20,
 M12 x 25,
 M12 x 30mm.

- UNF Kit Contents:**
 3/16 x 1/2, 3/16 x 3/4,
 3/16 x 1, 1/4 x 3/4,
 1/4 x 1, 1/4 x 1 1/4,
 5/16 x 3/4, 5/16 x 1,
 5/16 x 1 1/2, 3/8 x 3/4,
 3/8 x 1, 3/8 x 1 1/2.



Type	Average Quantity	Weight each	Order Code KEN-615	Price/1 TB
Metric	100	1.15kg	-4630K	1300.00
UNF	100	1.20kg	-4640K	1133.00

Metric Socket Set Screws

Cup Point
Sizes: M4 x 4, 8 and 10. M5 x 5, 8, 10. M6 x 6, 8, 10 and 12. **DIN 916.**



Average Quantity	Weight each	Order Code KEN-615	Price/1 TB
2000	1.87kg	-5140K	1494.00

GROUP 615 FASTENER ASSORTMENTS

MATLOCK Screw Organiser

2880 Pieces
Silver-TT™ Twin Thread Woodscrew Set

Set Contents:

- No.6 x 3/4" (325),
- No.6 x 1" (375),
- No.8 x 1" (575),
- No.8 x 1 1/4" (400),
- No.8 x 1 1/2" (300),
- No.8 x 2" (200),
- No.8 x 2 1/2" (75),
- No.10 x 2" (70),
- No.10 x 2 1/2" (60),
- No.10 x 3" (50).

Fixing Plugs:

- red 5.5mm (300),
- brown 7mm (150).



METAL CASE

Type	Weight each	Order Code MTL-615	Price/1 TB
Wood Screws	9.15kg	-0010K	3605.00

Screw Organiser

2880 Pieces
Gold-ZP™ Fibre Board Woodscrew Set

Set Contents:

- 3.5 x 20mm (325),
- 3.5 x 25 (375),
- 4.0 x 25 (575),
- 4.0 x 30(400),
- 4.0 x 40 (300),
- 4.0 x 50 (200),
- 4.0 x 60 (75),
- 5.0 x 50(70),
- 5.0 x 60 (60),
- 5.0 x 70 (50).

Fixing Plugs:

- red 5.5mm (300),
- brown 7mm (150).



METAL CASE

Type	Average Quantity	Order Code MTL-615	Price/1 TB
Fibreboard Screws	2880	-0020K	3605.00

KENNEDY Fix-it Kits

Self-Tapping Screws

Contents:

Slotted Zinc-Plated Countersunk: 4 x 1/4, 4 x 5/8, 4 x 3/4, 6 x 1/2, 6 x 3/4, 6 x 1, 8 x 1/2, 8 x 3/4, 8 x 1, 10 x 1/2, 10 x 3/4, 10 x 1.

Pan Head: 4 x 1/2, 4 x 3/4, 6 x 1/2, 6 x 3/4, 8 x 1/2, 8 x 3/4, 10 x 1/2, 10 x 3/4, 10 x 1mm.

Pozi Pan Head: 4 x 1/2, 6 x 1/2, 8 x 1/2, 10 x 1/2, 12 x 1/2, 4 x 3/4, 6 x 3/4, 8 x 3/4, 10 x 3/4, 12 x 3/4, 6 x 1, 8 x 1, 10 x 1.

Flange: 1/2 x 6, 5/8 x 6, 3/4 x 6, 1/2 x 8, 3/4 x 8, 1/2 x 10, 3/4 x 10mm.

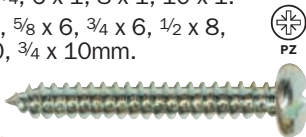

Type	Average Quantity	Order Code KEN-615	Price/1 TB
Countersunk	700	-4050K	909.00
Pan Head (s)	700	-4060K	629.00
Pan Head (p)	700	-4600K	850.00
Flange	700	-4610K	850.00

Round Head Wood Screws

Contents:

Brass Slotted: 4 x 18, 6 x 18, 6 x 25, 8 x 18, 8 x 25, 8 x 38, 10 x 38, 10 x 50mm.



NEW



Type	Avg Qty	Weight each	Order Code KEN-615	Price/1 TB
Wood Screws	375	1.30kg	-4720K	2500.00

Countersunk Wood Screws

Contents:

Slotted Zinc-Plated: 1/2 x 4, 3/4 x 4, 3/4 x 6, 1 x 6, 1/2 x 8, 3/4 x 8, 1 x 10, 1 1/2 x 10mm.

Pozidriv® Zinc-Plated: 1/2 x 4, 3/4 x 4, 3/4 x 6, 1 x 6, 1/2 x 8, 3/4 x 8, 1 x 10, 1 1/2 x 10mm.



Type	Average Quantity	Order Code KEN-615	Price/1 TB
Zinc Slotted	350	-4360K	1395.00
Pozidriv®	350	-4370K	716.00

Wire Nails

Contents:

Round wire: 1, 1 1/2, 2, 2 1/2".
Oval wire: 1, 1 1/2, 2, 2 1/2".



Type	Avg Qty	Weight each	Order Code KEN-615	Price/1 TB
Wood Nails	525	1.35kg	-4340K	691.00

Wall Plugs

Contents: yellow, red, brown and blue.



Type	Average Quantity	Order Code KEN-615	Price/1 TB
Wall Plugs	220	-4740K	443.00

Masonry Nails

Contents:

25, 30, 50 and 60mm.



NEW

Type	Avg Qty	Weight each	Order Code KEN-615	Price/1 TB
Masonry Nails	450	2.10kg	-4700K	1200.00

SENATOR Nail Hardware Kit

Contents includes:

Bright Nails: 1.3 x 22.2mm - x100, 2.0 x 25.4mm - x80, 1.7 x 31.8mm - x80, 2.1 x 38.1mm - x50, 2.0 x 38.1mm - x30 and 2.6 x 50.8mm - x20.

Panel Pins: 1.6 x 31.8mm - x80 and 1.7 x 25.4mm - x80.

Masonry Nails: 2.3 x 31mm - x30.

NEW



Type	Average Quantity	Order Code SEN-615	Price/1 TB
Nail Hardware Kit	550	-6010K	205.00

FASTENERS

KENNEDY Fix-it Kits
QUALITY INDUSTRIAL TOOLING

NEW

Metric Socket Screws - BZP

Button Head

Sizes: M5 x 12, 16 and 20. M6 x 12, 16, 20 and 25. M8 x 20, 25 and 30.
ISO 7380.



Average Quantity	Weight each	Order Code KEN-615	Price/1 TB
310	1.80kg	-5020K	1288.00

Metric Socket Screws - Button Head

Sizes: M5 x 12, 16 and 20. M6 x 12, 16, 20 and 25. M8 x 20, 25 and 30.
ISO 7380.

NEW



Average Quantity	Weight each	Order Code KEN-615	Price/1 TB
310	1.80kg	-5010K	1288.00

Metric Socket Screws - BZP

Cap Head

Sizes: M5 x 12, 16 and 20. M6 x 12, 16, 20 and 25. M8 x 16, 20 and 25.
DIN 912. Grade 12.9.

NEW



Average Quantity	Weight each	Order Code KEN-615	Price/1 TB
240	1.91kg	-5060K	1288.00

Cap Screws - Socket Head

Metric Kit Contents:

M5 x 16, M5 x 20, M6 x 20, M6 x 25, M8 x 25, M8 x 30, M10 x 25, M10 x 30, M12 x 20, M12 x 25, M12 x 30mm.

UNF Kit Contents:

3/16 x 1/2, 3/16 x 3/4, 3/16 x 1, 1/4 x 3/4, 1/4 x 1, 1/4 x 1 1/4, 5/16 x 3/4, 5/16 x 1, 5/16 x 1 1/2, 3/8 x 3/4, 3/8 x 1, 3/8 x 1 1/2.

BEST SELLER



Type	Average Quantity	Order Code KEN-615	Price/1 TB
Metric	100	-4630K	1300.00
UNF	100	-4640K	1133.00

Metric Socket Head Countersunk Screws

Metric: M5 x 12, M5 x 16, M5 x 20, M6 x 12, M6 x 16, M6 x 20, M6 x 25, M8 x 20, M8 x 25, M8 x 30
DIN 7991.

NEW



Average Quantity	Weight each	Order Code KEN-615	Price/1 TB
410	1.99kg	-5090K	1339.00

Metric Socket Screws - BZP

Countersunk

Sizes: M5 x 12, 16 & 20. M6 x 12, 16, 20 and 25. M8 x 20, 25 and 30.
DIN 7991.

NEW



Average Quantity	Weight each	Order Code KEN-615	Price/1 TB
410	2.00kg	-5100K	1339.00

Metric Socket Set Screws

Cup Point

Sizes: M4 x 4, 8 and 10. M5 x 5, 8, 10. M6 x 6, 8, 10 and 12.
DIN 916.

NEW



Average Quantity	Weight each	Order Code KEN-615	Price/1 TB
2000	1.87kg	-5140K	1494.00

Set Screws, Nuts & Washers

Contents:

Metric: Grade 8.8: M6 x 25, M6 x 40, M8 x 25, M8 x 40 and M10 x 25, M10 x 40mm.

UNF: Grade 'S': 1/4" x 3/4", 1/4" x 1", 5/16" x 1", 5/16" x 1 1/4", 3/8" x 1", 3/8" x 1 1/2".

UNC: Grade 'S': 1/4" x 3/4", 1/4" x 1", 5/16" x 1", 5/16" x 1 1/4", 3/8" x 1", 3/8" x 1 1/2".



Type	Average Quantity	Weight each	Order Code KEN-615	Price/1 TB
Metric	288	2.2kg	-4110K	1250.00
UNF	264	2.1kg	-4120K	1380.00
UNC	264	2.2kg	-4130K	1380.00

PRODUCTS ARE ONLY AVAILABLE VIA YOUR DISTRIBUTOR

GROUP 615 FASTENER ASSORTMENTS

KENNEDY Fix-it Kits
QUALITY INDUSTRIAL TOOLING

Machine Screws & Nuts

Steel - Pan Head:
M3 x 12, M3 x 16,
M3 x 20, M4 x 8,
M4 x 10, M4 x 12,
M4 x 16, M4 x 20,
M4 x 25, M5 x 10,
M5 x 12, M5 x 16,
M5 x 20, M6 x 10,
M6 x 12, M6 x 16,
M6 x 20 and
M6 x 25.

Brass - Round Head Plus Washers:

4BA x 3/4",
4BA x 1",
4BA x 1 1/2",
2BA x 3/4",
2BA x 1" and
2BA x 1 1/2".



EXTENDED RANGE

Type	Average Quantity	Weight each	Order Code KEN-615	Price/1 TB
Steel	600	1.15kg	-4290K	1868.00
Brass	390	1.90kg	-4300K	2250.00

KENNEDY Fix-it Kits
QUALITY INDUSTRIAL TOOLING

Metric Nylon Machine Screw, Nut & Washer Kit

Contents (25 of each):
Countersunk head - Slotted

Plus Nuts & Washers:
M3 x 8, M3 x 16, M4 x 8, M4 x 16, M4 x 20,
M5 x 8 and M5 x 16,

Cheese head - Slotted + Nuts & Washers:
M3 x 6, M3 x 12, M3 x 25, M4 x 8, M4 x 6,
M4 x 12, M4 x 25, M5 x 6, M5 x 12
and M5 x 25.



Type	Avg Qty	Weight each	Order Code KEN-615	Price/1 TB
Nylon	525	577g	-4100K	2918.00

Nyloc Zinc Plated Nuts

Contents:
M5, M6, M8, M10, M12, M14 and M16.



Type	Avg Qty	Weight each	Order Code KEN-615	Price/1 TB
Metric	300	1.10kg	-4180K	1009.00

SENATOR Fix-it Kits
QUALITY TOOLING

Set Screws, Nuts & Washers - BZP

Made from bright zinc plated machine and tempered low carbon steel, rust- and corrosion-resistant.

NEW

Contents:

Screws:	Nuts:	Washers:
M4 x 12 - x10,	M4 - x20,	M4 - x20,
M4 x 20 - x10,	M5 - x20,	M5 - x20,
M5 x 16 - x10,	M6 - x20,	M6 - x20,
M5 x 25 - x10,	M8 - x10,	M8 - x10,
M6 x 20 - x10,	M10 - x10,	M10 - x10.



Type	Average Quantity	Order Code SEN-615	Price/1 TB
Set Screws, Nuts & Washers Kit	240	-6110K	232.00

Metric Nuts & Bolts

Mild Steel. Grade 4.6.

Contents: M6 x 20, M6 x 40, M6 x 45,
M8 x 25, M8 x 30, M8 x 35 and
M8 x 50mm.



Average Quantity	Weight each	Order Code KEN-615	Price/1 TB
200	1.70kg	-4030K	495.00

Zinc Plated Wing Nuts

Contents: M4, M5, M6, M8 and M10.

BEST SELLER



Average Quantity	Weight each	Order Code KEN-615	Price/1 TB
100	0.50kg	-4210K	1115.00

Internal Disc Lock Washers - Metric

Contents: M5, M6, M8 and M10.

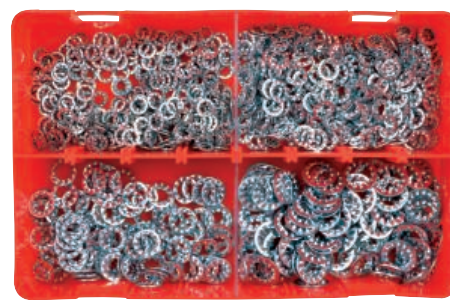

Washer Type	Average Quantity	Order Code KEN-615	Price/1 TB
Internal Lock	750	-4250K	1221.00

Cold Formed Zinc Plated Nuts

Contents:
M5, M6, M8, M10 and M12.



Type	Avg Qty	Weight each	Order Code KEN-615	Price/1 TB
Metric	375	1.40kg	-4150K	797.00

FASTENERS

FASTENER ASSORTMENTS

KENNEDY Fix-it Kits
QUALITY INDUSTRIAL TOOLING

BEST SELLER

Plain Washers - Metric

Contents: M5, M6, M8, M10 and M12mm.



Washer Type	Average Quantity	Order Code KEN-615	Price/1 TB
Plain	1500	-4230K	1250.00

Mudguard Washers - Metric

Contents: M5, M6, M8 and M10mm.

BEST SELLER



Type	Avg Qty	Weight each	Order Code KEN-615	Price/1 TB
Metric	220	1.45kg	-4270K	1360.00

Brass Cup Washers - Metric

Contents: No. 4, 6, 8, 10, 12 and 14mm.



Washer Type	Average Quantity	Order Code KEN-615	Price/1 TB
Cup	465	-4330K	1597.00

Starlock Washers, Uncapped - Inch

Contents: 3/32", 1/8", 5/32", 3/16", 1/4", 5/16", 3/8", 7/16", 1/2", 5/8" and 3/4".



Washer Type	Average Quantity	Order Code KEN-615	Price/1 TB
Starlock	585	-4320K	2050.00

Panel Clips

Contents:

U-Type: No.6, No.8, No.10, No.12 and No.14,

J-Type: No.6, No.8, No.10, No.12 and No.14.



Washer Type	Average Quantity	Order Code KEN-615	Price/1 TB
Panel Clips	300	-4480K	1354.00

Plain Copper Washers - Metric

Contents: M5, M6, M8, M10 and M12mm.

BEST SELLER



Washer Type	Average Quantity	Order Code KEN-615	Price/1 TB
Copper	300	-4690K	1469.00

Square Section Spring Washers - Metric BZP

Contents: M5, M6, M8, M10 and M12.

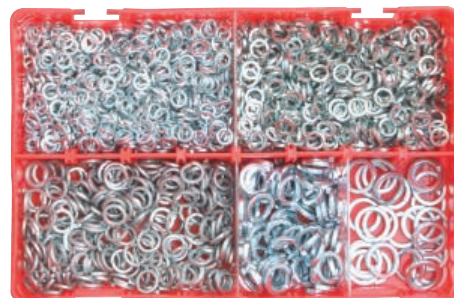

Washer Type	Weight each	Order Code KEN-615	Price/1 TB
Square Spring	915g	-4240K	1236.00

External Disc Lock Washers - Metric

Contents:

M5, M6, M8, and M10.

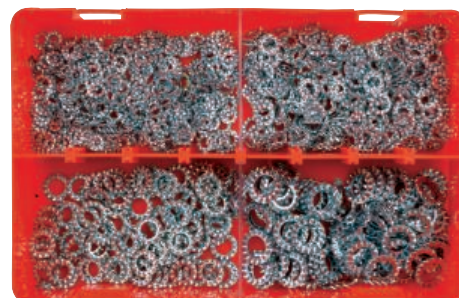

Washer Type	Average Quantity	Order Code KEN-615	Price/1 TB
External Lock	750	-4260K	1185.00

SENATOR Fix-it Kits
QUALITY TOOLING

NEW

Flat & Spring Washers

Contents:

Flat Washers (diameter):

4mm - x120, 5mm - x100, 6mm - x80, 8mm - x50, 10mm - x30 and 12mm - x15.

Spring Washers (diameter):

4mm - x120, 5mm - x100, 6mm - x80, 8mm - x50, 10mm - x30 and 12mm - x15.



Type	Average Quantity	Order Code SEN-615	Price/1 TB
Flat & Spring Washer Kit	790	-3810K	199.00

GROUP 615 FASTENER ASSORTMENTS

KENNEDY Fix-it
QUALITY INDUSTRIAL TOOLING Kits

Blind Grommets

Made from chemical/heat resistant nylon 66 with a flammability rating of UL94V-2 and material temperature index: 125°C.

Contents: diameters from 4.8 - 45mm for maximum panel thickness from 1.6 - 3.2mm.

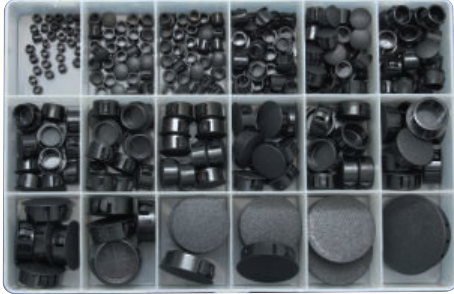

Average Qty	Weight each	Order Code KEN-615	Price/1 TB
260	485g	-4760K	3225.00

Wiring Grommets

Contents: 6, 8, 10, 11, 12, 14, 18 and 20mm.



Type	Avg Qty	Weight each	Order Code KEN-615	Price/1 TB
Wiring Grommets	100	252g	-4580K	823.00

Grommets

Contents: 5/16", 3/8", 1/2", 5/8", 3/4", 7/8", 15/16" and 1".



Average Quantity	Weight each	Order Code KEN-615	Price/1 TB
120	0.35kg	-4560K	747.00

Fibre Washers - Metric

Contents: M5, M6, M8, M10 and M12.



Washer Type	Average Quantity	Order Code KEN-615	Price/1 TB
Fibre	600	-4280K	1751.00

Metric 'O' Rings

Contents: M6, M10, M11, M14, M17, M21, M24 and M25.

BEST SELLER



Type	Avg Qty	Weight each	Order Code KEN-615	Price/1 TB
Metric 'O' Rings	400	0.30kg	-4900K	821.00

SENATOR Fix-it
QUALITY TOOLING Kits

Interior Circlips

These are constructed from durable spring steel and are black oxide treated for extra strength.

NEW

Contents:

3mm - x20,	14mm - x15,
4mm - x10,	16mm - x20,
5mm - x15,	19mm - x25,
6mm - x25,	20mm - x15,
8mm - x15,	22.5mm - x20,
9mm - x20,	25mm - x15,
11mm - x15,	26mm - x15,
12mm - x15,	28mm - x10,
13mm - x25,	32mm - x5.



Type	Average Quantity	Order Code SEN-615	Price/1 TB
Internal Circlip Kit	300	-4520K	308.00

Circlips

Contents:

Internal: 14, 16, 19, 22, 24 and 25mm.

External: 12, 14, 16, 19, 22, 24 and 25mm.

BEST SELLER



Type	Avg Qty	Weight each	Order Code KEN-615	Price/1 TB
Circlips	380	0.5kg	-4470K	1300.00

E Clip Kit

Contents: 3.2, 4, 5, 6, 8, 10 and 12mm.

NEW



Type	Average Quantity	Order Code KEN-615	Price/1 TB
E Clip Kit	355	-4475K	1288.00

Exterior Circlips

These are constructed from durable spring steel and are black oxide treated for extra strength.

NEW

Contents:

3mm - x20,	14mm - x15,
4mm - x10,	16mm - x20,
5mm - x15,	19mm - x25,
6mm - x25,	20mm - x15,
8mm - x15,	22.5mm - x20,
9mm - x20,	25mm - x15,
11mm - x15,	26mm - x15,
12mm - x15,	28mm - x10,
13mm - x25,	32mm - x5.



Type	Average Quantity	Order Code SEN-615	Price/1 TB
External Circlip Kit	300	-4510K	308.00

FASTENERS

KENNEDY Fix-it
QUALITY INDUSTRIAL TOOLING® Kits

BEST SELLER

Spring Tension Pins

Contents:

2.5 x 24, 2.5 x 40, 3 x 25, 3 x 40, 4 x 24, 4 x 30, 5 x 25, 5 x 40, 6 x 25, 6 x 32 and 8 x 55mm.



Type	Avg Qty	Weight each	Order Code KEN-615	Price/1 TB
Roll Clips	300	0.80kg	-4500K	1494.00

Dowel Pin Kit - Metric & Inch

Hardened and precision ground. DIN 6325.

Metric Sizes: 1.5 x 8mm through to 8 x 32mm.

NEW

Inch Sizes: 1/16" x 1/2" through to 3/8" x 2".



Metric/Inch	Average Quantity	Order Code KEN-615	Price/1 TB
Metric	265	-4510K	2163.00
Inch	345	-4520K	2575.00

Clevis Pins

Contents: 3/16" x 5/8", 3/16" x 1", 1/4" x 3/4", 1/4" x 7/8", 1/4" x 1", 1/4" x 1 1/2", 5/16" x 3/4", 5/16" x 1", 5/16" x 1 1/4", 5/16" x 1 1/2", 5/16" x 1 3/4" and 3/8" x 1", 3/8" x 1 1/4".



Type	Avg Qty	Weight each	Order Code KEN-615	Price/1 TB
Clevis Pins	170	1.25kg	-4490K	3151.00

Retaining Clips

Contents (D x L): 5 - 7 x 1.2, 7 - 9 x 1.2, 9 - 11 x 2, 14 - 16 x 3, 14 - 18 x 4mm.



Type	Avg Qty	Weight each	Order Code KEN-615	Price/1 TB
Retaining Clips	75	0.40kg	-4800K	547.00

Aluminium Dome Head Rivet Kit

Contents:

2.4 x 6mm - x200,
2.4 x 8mm - x200,
3.2 x 5mm - x100,
3.2 x 7mm - x100,
3.2 x 10mm - x100,
4.0 x 6mm - x75,
4.0 x 10mm - x75,
4.0 x 12mm - x60,
4.8 x 9mm - x50,
4.8 x 16mm - x40.



NEW



Type	Average Quantity	Weight each	Order Code KEN-615	Price/1 TB
Dome Head Rivets	1000	1.25kg	-4010K	1643.00

Compression & Expansion Springs

BEST SELLER

Contents:

Expansion Springs

Wire Dia. (mm)	Outside Dia. (mm)	Overall Length (mm)
0.70	6.29	31.5
0.50	4.70	40.0
0.60	6.29	51.5
0.60	6.29	64.5
0.60	4.70	58.0
0.80	9.80	70.0

Compression Springs

Wire Dia. (mm)	Outside Dia. (mm)	Overall Length (mm)
0.70	8.90	50.0
0.50	6.00	25.0
1.00	8.90	50.0
1.00	8.90	25.0
0.50	6.00	50.0
1.00	7.40	50.0



Type	Avg Qty	Weight each	Order Code KEN-615	Price/1 TB
Springs	140	0.55kg	-6590K	1365.00

Woodruff Keys

Contents:

1/2" x 1/16", 1/2" x 3/32", 1/2" x 1/8", 5/8" x 3/32", 5/8" x 1/8", 5/8" x 5/32", 5/8" x 3/16", 3/4" x 1/8", 3/4" x 5/32", 3/4" x 3/16", 3/4" x 1/4", 7/8" x 5/32", 7/8" x 3/16", 7/8" x 7/32" and 7/8" x 1/4".



Washer Type	Average Quantity	Order Code KEN-615	Price/1 TB
Woodruff Keys	100	-4540K	2009.00

Split Cotter Pins

BEST SELLER

Large:

1/8" x 1 1/2", 1/8" x 2", 9/64" x 2", 5/32" x 1 1/2", 5/32" x 2", 3/16" x 1 1/2", 3/16" x 2" and 1/4" x 2".

Small:

1/16" x 1", 5/64" x 1", 3/32" x 1", 1/8" x 1", 9/64" x 1 1/2", 1/16" x 1 1/2", 5/64" x 1 1/4", 3/32" x 1 1/2", 7/64" x 1 1/2", 1/8" x 1 1/2" and 5/32" x 1 1/2".



Type	Avg Qty	Weight each	Order Code KEN-615	Price/1 TB
Large	200	1.35kg	-4420K	1029.00
Small	1000	1.00kg	-4430K	1236.00

SENATOR Fix-it
QUALITY TOOLING® Kits

Assorted Split Cotter Pins
Zinc plated to prevent rust.

Contents:

1/16" x 1" - x150, 3/32" x 1" - x150, 3/32" x 1 1/2" - x100, 1/8" x 1 1/4" - x75, 1/8" x 2" - x50 and 5/32" x 2 1/2" - x30.

NEW



Type	Average Quantity	Order Code SEN-615	Price/1 TB
Assorted Split Cotter Pins	555	-7810K	308.00

GROUP 615 FASTENER ASSORTMENTS

QUALFAST *Fix-it Kits*

A4 Stainless Steel Metric Nut & Washer Kit

Contents:

Nuts:
M5 - x150, M6 - x100, M8 - x50, M10 - x25, M12 - x15,

Washers:

M5 - x200, M6 - x150, M8 - x100, M10 - x50 and M12 - x50.

NEW



Washer Type	Average Quantity	Order Code QFT-615	Price/1 TB
Metric	890	-4630K	2266.00

A4 Stainless Steel Metric Nut Kit

Contents:

M3 - x250, M4 - x200, M5 - x150, M6 - x100, M8 - x50, M10 - x25, M12 - x15, M16 - x9, M20 - x4 and M24 - x2.

NEW



Washer Type	Average Quantity	Order Code QFT-615	Price/1 TB
Metric	805	-4610K	2266.00

A4 Stainless Steel Metric Washer Kit

Contents:

M3 - x300, M4 - x250, M5 - x200, M6 - x150, M8 - x100, M10 - x50, M12 - x50, M16 - x25, M20 - x10 and M24 - x5.

NEW



Washer Type	Average Quantity	Order Code QFT-615	Price/1 TB
Metric	1140	-4620K	2266.00

Brass Fastener Assortments Brass Hex Nuts & Washer Set

Contents:

M6 - x12, M6 - x16, M6 - x20, M6 - x25, M8 - x16, M8 - x20, M8 - x25, M8 - x30, M10 - x25 and M10 - x30.

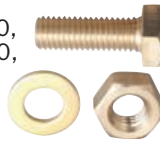

Type	Avg Qty	Weight each	Order Code QFT-615	Price/1 TB
Metric	110	2.2kg	-5400K	2918.00



Brass Slot CSK Woodscrew Kit

Contents:

3.5 - x16, 3.5 - x20, 3.5 - x25, 4.0 - x20, 4.0 - x25, 4.0 - x30, 5.0 - x25, 5.0 - x30, 5.0 - x40 and 5.0 - x50.



Type	Avg Qty	Weight each	Order Code QFT-615	Price/1 TB
Metric	625	2.1kg	-5430K	2706.00



Brass Slot Pan M/C Nuts & Washer Set

Contents:

M4 x 8, M4 x 10, M4 x 12, M4 x 16, M5 x 16, M5 x 20, M6 x 12, M6 x 16, M6 x 20 and M6 x 25mm.

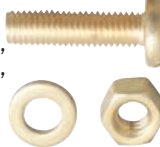

Type	Average Quantity	Order Code QFT-615	Price/1 TB
Metric	310	-5460K	2706.00

Brass Slot CSK M/C Nut & Washer Set

Contents:

M4 x 8, M4 x 10, M4 x 12, M4 x 16, M5 x 16, M5 x 20, M6 x 12, M6 x 16, M6 x 20 and M6 x 25mm.



Type	Average Quantity	Order Code QFT-615	Price/1 TB
Metric	310	-5470K	2706.00

Brass Metric Nut

Contents:

M2.5 - x250, M3 - x200, M4 - x150, M5 - x100, M6 - x50, M8 - x25, M10 - x15, M12 - x10, M16 - x8 and M20 - x4.

NEW



Type	Average Quantity	Order Code QFT-615	Price/1 TB
Metric	812	-5510K	2575.00

Brass Metric Washer

Contents:

M2.5 x 300, M3 x 250, M3.5 x 250, M4 x 200, M5 x 150, M6 x 100, M8 x 50, M10 x 50, M12 x 25 and M16 x 5.

NEW



Type	Average Quantity	Order Code QFT-615	Price/1 TB
Metric	1380	-5520K	2678.00

FASTENERS

QUALFAST Stainless Fastener Assortments

A2 Stainless Steel Pozi Pan head CSK Self-tapping Screw Kits

Contents:
CSK STS: 2.9 x 13, 2.9 x 16, 3.5 x 13, 3.5 x 19, 3.5 x 25, 4.2 x 13, 4.2 x 19, 4.2 x 25, 4.8 x 16 and 4.8 x 25mm.

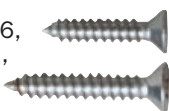

Type	Average Quantity	Order Code QFT-615	Price/1 TB
Pozi CSK	900	-4440K	1906.00

A2 Stainless Steel Pozi Pan Head Self-tapping Screw Kits

Contents:
PAN STS: 2.9 x 13, 2.9 x 16, 3.5 x 13, 3.5 x 19, 3.5 x 25, 4.2 x 13, 4.2 x 19, 4.2 x 25, 4.8 x 16 and 4.8 x 25mm.

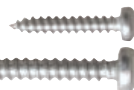

Type	Average Quantity	Order Code QFT-615	Price/1 TB
Pozi PAN	900	-4450K	1906.00

A2 Stainless Steel Pozi CSK Woodscrew Kit

Contents: 3.5 x 16, 3.5 x 20, 3.5 x 25, 4.0 x 20, 4.0 x 25, 4.0 x 30, 5.0 x 25, 5.0 x 30, 5.0 x 40 and 5.0 x 50mm.

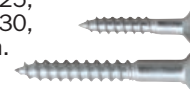

Type	Average Quantity	Order Code QFT-615	Price/1 TB
Metric	625	-4430K	1906.00

A2 Stainless Steel Pozi Pan Head Machine Screw Kits

Contents:
PAN: M4 x 10, M4 x 12, M4 x 16, M5 x 16, M5 x 20, M6 x 12, M6 x 16, M6 x 20 and M6 x 25mm.

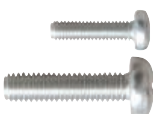

Type	Average Quantity	Order Code QFT-615	Price/1 TB
Pozi PAN	400	-4460K	1906.00

A2 Stainless Steel Pozi CSK Machine Screw Kits

Contents:
CSK: M4 x 10, M4 x 12, M4 x 16, M5 x 16, M5 x 20, M6 x 12, M6 x 16, M6 x 20 and M6 x 25mm.

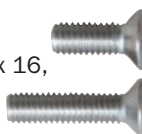

Type	Average Quantity	Order Code QFT-615	Price/1 TB
Pozi CSK	500	-4470K	1906.00

A2 Stainless Steel Socket Button Screw Kit

Contents: M5 x 12, M5 x 16, M5 x 20, M6 x 12, M6 x 16, M6 x 20, M6 x 25, M8 x 20, M8 x 25 and M8 x 30mm.

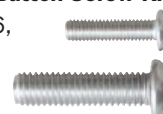

Type	Average Quantity	Order Code QFT-615	Price/1 TB
Metric	310	-4420K	1906.00

A2 Stainless Steel CSK Socket Screw Kit

Contents: M5 x 12, M5 x 16, M5 x 20, M6 x 12, M6 x 16, M6 x 20, M6 x 25, M8 x 20, M8 x 25 and M8 x 30mm.

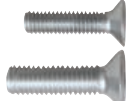

Washer Type	Average Quantity	Order Code QFT-615	Price/1 TB
Metric	310	-4410K	1906.00

A2 Stainless Steel Socket Cap Screw Kit

Contents: 5 x 12, 5 x 16, 5 x 20, 6 x 12, 6 x 16, 6 x 20, 6 x 25, 8 x 16, 8 x 20 and 8 x 25mm.



Washer Type	Average Quantity	Order Code QFT-615	Price/1 TB
Metric	250	-4380K	1906.00

A2 Stainless Steel Hex Set Screw Kit

Contents: M6 x 12, M6 x 16, M6 x 20, M6 x 25, M8 x 20, M8 x 25, M8 x 30, M10 x 25 and M10 x 20mm.



Type	Average Quantity	Order Code QFT-615	Price/1 TB
Metric	200	-4390K	1906.00

A2 Stainless Steel Nuts & Washer Kit Plus Nyloc Nut Kit

Contents:
Full Nuts: M5, M6, M8, M10 and M12.
Form B: M5, M6, M8, M10 and M12.



Type	Average Quantity	Weight each	Order Code QFT-615	Price/1 TB
Metric	890	1.7kg	-4400K	1906.00
Metric	1087	2.6kg	-4480K	3005.00

Nyloc Nuts: M3, M4, M5, M6, M8, M10, M12, M14, M16 and M20.



Type	Average Quantity	Weight each	Order Code QFT-615	Price/1 TB
Metric	890	1.7kg	-4400K	1906.00
Metric	1087	2.6kg	-4480K	3005.00

A4 Stainless Steel Metric Hex Head Screw Kit

Contents: M6 x 12 x 25, M6 x 16 x 25, M6x20 x 25, M6 x 25 x 25, M8 x 16 x 20, M8x20 x 20, M8 x 25 x 20, M8 x 30 x 20, M10 x 25 x 10 and M10 x 30 x 10mm.



Type	Average Quantity	Order Code QFT-615	Price/1 TB
Metric	200	-4640K	2200.00

NEW

FASTENERS

GROUP 620 THREAD REPAIR

KENNEDY PROFESSIONAL

Wire Thread Insert Kits



Suitable for repairing damaged and worn threads, also ideal for new applications. Ideal for use with alloys and other light materials. Can also be used for converting from metric to inch and vice versa. 1 1/2" x diameter in length. Other lengths are available on request. Each kit supplied with inserts, HSS hand tap, insertion tool and instructions.

Kits come complete with: Hand Tap, Inserting Tool and Inserts.

† Includes Punch.

* Includes Drill and Punch.

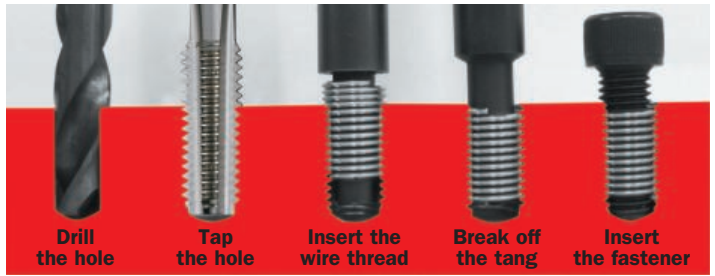

Thread Form	Tap Size	Clearance Drill Size	Inserts/Kit	Weight each	Order Code KEN-621	Price/1 TB
Metric	M3 x 0.50*	3.20	10	105g	-1120K	1730.00
Metric	M4 x 0.70*	4.20	10	122g	-1160K	1804.00
Metric	M5 x 0.80*	5.20	10	142g	-1200K	1819.00
Metric	M6 x 1.00*	6.20	10	169g	-1240K	1836.00
Metric	M7 x 1.00*	7.20	10	190g	-1280K	1915.00
Metric	M8 x 1.00*	8.30	10	162g	-1320K	2075.00
Metric	M8 x 1.25*	8.30	10	180g	-1340K	2075.00
Metric	M10 x 1.00*	10.25	10	226g	-1400K	2234.00
Metric	M10 x 1.25*	10.25	10	226g	-1420K	2340.00
Metric	M10 x 1.50*	10.40	10	225g	-1430K	2446.00
Metric	M12 x 1.25†	12.25	10	309g	-1480K	2441.00
Metric	M12 x 1.50†	12.25	5	309g	-1490K	3294.00
Metric	M12 x 1.75†	12.50	5	290g	-1500K	3294.00
Metric	M14 x 1.25	14.25	5	459g	-1560K	3401.00
Metric	M14 x 1.50	14.25	5	325g	-1580K	3401.00
Metric	M14 x 2.00	14.50	5	325g	-1600K	3401.00
Metric	M16 x 1.50	16.50	5	343g	-1640K	3560.00
Metric	M16 x 2.00	16.50	5	354g	-1660K	3560.00
UNC	No.4 - 40*	No.31	10	109g	-2040K	2234.00
UNC	No.8 - 32*	11/64"	10	123g	-2080K	2234.00
UNC	1/4" - 20*	17/64"	10	166g	-2160K	2234.00
UNC	5/16" - 18*	21/64"	10	201g	-2200K	2446.00
UNC	3/8" - 16*	25/64"	10	226g	-2240K	2552.00
UNC	1/2" - 13	17/32"	10	293g	-2320K	2658.00
UNF	No.10 - 32*	13/64"	10	138g	-3100K	2234.00
UNF	1/4" - 28*	17/64"	10	160g	-3160K	2234.00
UNF	5/16" - 24*	21/64"	10	216g	-3200K	2446.00
UNF	3/8" - 24*	25/64"	10	218g	-3240K	2552.00
UNF	1/2" - 20	33/64"	5	289g	-3320K	2658.00

Threading Inserts

Range now extended to include 1 x D and 2 x D lengths (ISO Metric threads). Our quality inserts are now supplied in packs of 10 or 50. Other sizes and lengths are available on request, please ask for further information. Insert length = 1.5 x D.

ISO Metric Threads	Insert Length	Thread x Pitch	Clearance Drill (mm)	Packs of 10 Inserts		Packs of 50 Inserts	
				Order Code KEN-620	Price/Pk TB	Order Code KEN-620	Price/Pk TB
1xD	M3 x 0.50	3.20	-5502K	165.00	-7402K	642.00	
	M4 x 0.70	4.20	-5504K	165.00	-7404K	642.00	
	M5 x 0.80	5.20	-5505K	165.00	-7405K	590.00	
	M6 x 1.00	6.20	-5506K	191.00	-7406K	615.00	
	M7 x 1.00	7.20	-5507K	202.00	-7407K	642.00	
	M8 x 1.00	8.30	-5508K	202.00	-7408K	854.00	
	M8 x 1.25	8.30	-5509K	202.00	-7409K	696.00	
	M10 x 1.00	10.25	-5512K	271.00	-7412K	748.00	
	M10 x 1.25	10.25	-5513K	271.00	-7413K	854.00	
	M10 x 1.50	12.25	-5514K	271.00	-7414K	854.00	
1.5xD	M3 x 0.50	3.20	-6010K	165.00	-	-	
	M4 x 0.70	4.20	-6030K	165.00	-	-	
	M5 x 0.80	5.20	-6050K	165.00	-	-	
	M6 x 1.00	6.20	-6070K	191.00	-	-	
	M7 x 1.00	7.20	-6090K	202.00	-	-	
	M8 x 1.00	8.20	-6110K	202.00	-	-	
	M8 x 1.25	8.30	-6120K	202.00	-	-	
	M10 x 1.00	10.25	-6140K	271.00	-	-	
	M10 x 1.25	10.25	-6150K	271.00	-	-	
	M10 x 1.50	10.25	-6160K	271.00	-	-	
2xD	M12 x 1.25	12.25	-6180K	403.00	-	-	
	M12 x 1.50	12.25	-6190K	403.00	-	-	
	M12 x 1.75	12.50	-6200K	403.00	-	-	
	M14 x 1.25	14.25	-6220K	590.00	-	-	
	M14 x 1.50	14.25	-6230K	590.00	-	-	
	M14 x 2.00	14.50	-6240K	590.00	-	-	
	M16 x 1.50	16.50	-6260K	748.00	-	-	
	M16 x 2.00	16.50	-6270K	748.00	-	-	
	M3 x 0.50	3.20	-6302K	218.00	-7802K	908.00	
	M4 x 0.70	4.20	-6304K	218.00	-7804K	881.00	
M5 x 0.80	5.20	-6305K	218.00	-7805K	802.00		
M6 x 1.00	6.20	-6306K	245.00	-7806K	828.00		
M7 x 1.00	7.20	-6307K	255.00	-7807K	960.00		
M8 x 1.00	8.20	-6308K	255.00	-7808K	960.00		
M8 x 1.25	8.30	-6309K	255.00	-7809K	960.00		
M10 x 1.00	10.25	-6312K	324.00	-7812K	1597.00		
M10 x 1.25	10.25	-6313K	324.00	-7813K	1703.00		
M10 x 1.50	12.25	-6314K	324.00	-7814K	1703.00		

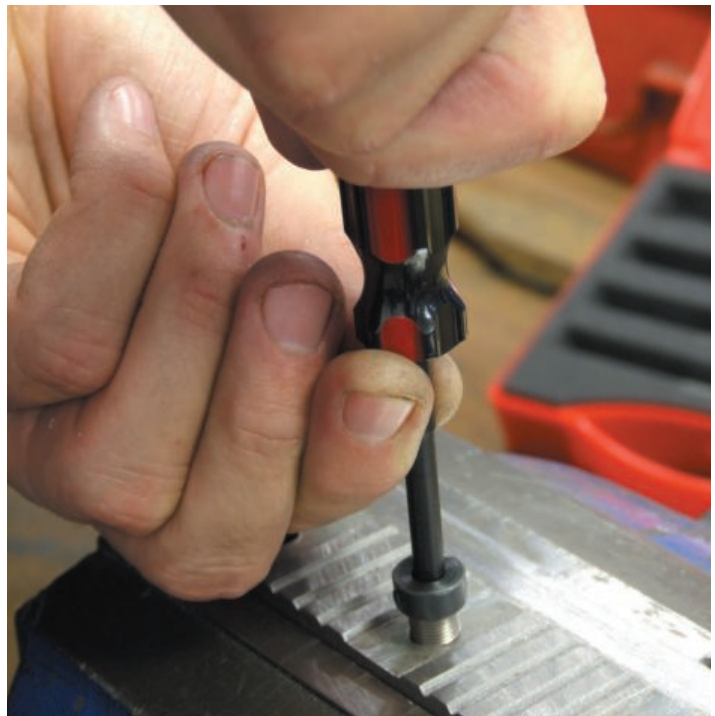

Insert Length	Thread x Pitch	Clearance Drill (mm)	Order Code KEN-620	Price/10 TB
UNC Threads				
1.5 x D	No.4 - 40	No.31	-6840K	170.00
	No.8 - 32	11/64"	-6880K	170.00
	1/4" - 20	17/64"	-6900K	271.00
	5/16" - 18	21/64"	-6910K	271.00
	3/8" - 16	25/64"	-6920K	297.00
1/2" - 13	17/32"	-6940K	377.00	
UNF Threads				
1.5 x D	No.10 - 32	13/64"	-7090K	271.00
	1/4" - 28	17/64"	-7100K	271.00
	5/16" - 24	21/64"	-7110K	271.00
	3/8" - 24	25/64"	-7120K	297.00
	1/2" - 20	33/64"	-7140K	377.00

FASTENERS

MATLOCK Pozidriv® Woodscrews

WOODSCREWS

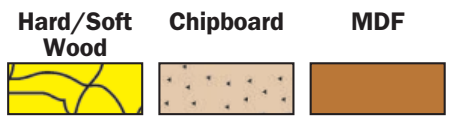

Gold-ZP™ Fibre Board Woodscrews
 For power driving into hard and soft wood, MDF and chipboard. Manufactured to reduce wood split. Heat-treated for high resistance to breakage. With an aggressive clean cutting single thread drives easily - even in MDF and chipboard. Passivated zinc-plated and lubricated to aid penetration. 25° point angle usually needs no pilot.

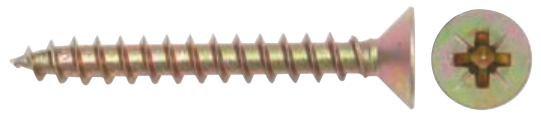

Metric

Size (mm)	Pack Qty	Order Code MTL-635	Price/Pk TB	Size (mm)	Pack Qty	Order Code MTL-635	Price/Pk TB
3.0 x 12	200	-1020K	83.00	4.0 x 45	200	-1190K	186.00
3.0 x 16	200	-1025K	62.00	4.0 x 50	200	-1200K	170.00
3.0 x 20	200	-1030K	62.00	4.0 x 55	200	-1210K	237.00
3.0 x 25	200	-1040K	83.00	4.0 x 60	200	-1220K	258.00
3.0 x 40	200	-1050K	108.00	4.0 x 70	200	-1225K	155.00
3.5 x 12	200	-1070K	83.00	4.0 x 75	200	-1230K	155.00
3.5 x 16	200	-1080K	83.00	4.5 x 25	200	-1240K	160.00
3.5 x 20	200	-1090K	73.00	4.5 x 40	200	-1260K	186.00
3.5 x 25	200	-1100K	88.00	5.0 x 30	200	-1300K	206.00
3.5 x 30	200	-1110K	108.00	5.0 x 40	200	-1320K	263.00
3.5 x 35	200	-1115K	121.00	5.0 x 45	200	-1325K	263.00
3.5 x 40	200	-1120K	102.00	5.0 x 50	200	-1330K	309.00
3.5 x 45	200	-1125K	124.00	5.0 x 60	200	-1340K	186.00
3.5 x 50	200	-1130K	134.00	5.0 x 70	100	-1360K	263.00
4.0 x 16	200	-1140K	83.00	5.0 x 80	100	-1380K	263.00
4.0 x 20	200	-1150K	93.00	5.0 x 90	100	-1390K	289.00
4.0 x 25	200	-1160K	98.00	5.0 x 100	100	-1400K	309.00
4.0 x 30	200	-1170K	134.00	6.0 x 80	100	-1420K	418.00
4.0 x 35	200	-1175K	145.00	6.0 x 100	100	-1440K	567.00
4.0 x 40	200	-1180K	186.00	6.0 x 130	100	-1470K	618.00

Screw Organisers

2880 Pieces
 High helix double thread, plated to five microns for greater corrosion-resistance. 35° point angle usually needs no pilot.

Gold-ZP™ Fibre Board Woodscrews
 Assorted sizes 3.5 x 20mm to 5.0 x 70mm

Silver-TT™ Twin Thread Woodscrews
 Assorted sizes No.6 x 3/4" to No.10 x 3" (50).

Fixing Plugs
 Red 5.5mm (300).
 Brown 7mm (150).

Fixing Plugs
 Red 5.5mm (300).
 Brown 7mm (150).



Screw Type	Order Code MTL-615	Price/1 TB
Silver-TT™ Wood Screws	-0010K	3605.00
Gold-ZP™ Fibreboard Screws	-0020K	3605.00

KENNEDY PROFESSIONAL Pro-Torq Screwdrivers

Chrome vanadium steel blades with magnetic tips. Fitted with a unique dual grip triangular handle designed for improved user comfort, allowing more torque to be applied. Manufactured with hanging hole in the handle for storage. **DIN ISO 2380/8764.**

8-Piece Set Contents (mm):
Crosspoint: No.2 x stubby, No.2 x 100.
PZ: No.1 x 75, No.2 x 100, No.3 x 150,
Flared: 6.3 x 150, 8.0 x 200.
Parallel: 5.0 x 150.

8 PIECES



Number of Pieces	Weight each	Order Code KEN-572	Price/1 TB
8	1105g	-6010K	1895.00

12-Piece Set Contents (mm):
Crosspoint: No.2 x stubby, No.2 x 100, No.3 x 150.
PZ: No.1 x 75 No.2 x 100 No.3 x 150.
Flared: 6.3 x stubby, 6.3 x 150, 9.5 x 250.
Parallel: 5.0 x 100, 5.0 x 200, 5.0 x 250.

12 PIECES



Number of Pieces	Weight each	Order Code KEN-572	Price/1 TB
12	1660g	-6020K	2865.00

12-Piece Set Contents (mm):
Crosspoint: No.2 x stubby, No.1 x 75, No.2 x 100, No.3 x 150.
PZ: No.2 x 100, No.3 x 150.
Flared: 6.3 x stubby, 6.3 x 150, 8.0 x 200.
Parallel: 5.0 x 75, 5.0 x 150, 5.0 x 250.

12 PIECES



Number of Pieces	Weight each	Order Code KEN-572	Price/1 TB
12	1467g	-6030K	2971.00

PRODUCTS ARE ONLY AVAILABLE VIA YOUR DISTRIBUTOR



Colour-coded at each end of length for easy identification as shown.

- Yellow = Metric
- Red = BSW
- White = UNC
- Green = BSF
- Orange = Grade 8.8
- Blue = UNF
- Black = Stainless Steel



EXTENDED RANGE

Mild Steel - Grade 4.6 Self-Colour

Thread	Length	Order Code QFT-639	Price/1 TB
● Metric			
M5	300mm	-0550K	47.00
M6	300mm	-0560K	37.00
M8	300mm	-0580K	42.00
M10	300mm	-0600K	52.00
M12	300mm	-0620K	83.00
M14	300mm	-0640K	201.00
M16	300mm	-0660K	155.00
M20	300mm	-0700K	181.00
M24	300mm	-0720K	201.00
M3	1m	-0030K	57.00
M4	1m	-0040K	57.00
M5	1m	-0050K	57.00
M6	1m	-0060K	67.00
M8	1m	-0080K	67.00
M10	1m	-0100K	78.00
M12	1m	-0120K	129.00
M14	1m	-0140K	181.00
M16	1m	-0160K	258.00
M20	1m	-0200K	387.00
M24	1m	-0240K	567.00
M30	1m	-0300K	979.00
M36	1m	-0360K	1288.00
○ UNC			
1/4"	3ft	-3040K	119.00
5/16"	3ft	-3050K	129.00
3/8"	3ft	-3060K	119.00
7/16"	3ft	-3070K	217.00
1/2"	3ft	-3080K	217.00
5/8"	3ft	-3100K	304.00
3/4"	3ft	-3120K	510.00
1"	3ft	-3160K	799.00
● UNF			
1/4"	3ft	-4040K	284.00
5/16"	3ft	-4050K	284.00
3/8"	3ft	-4060K	284.00
7/16"	3ft	-4070K	335.00
1/2"	3ft	-4080K	567.00

Mild Steel - Grade 4.6 Zinc-Plated

Thread	Length	Order Code QFT-639	Price/1 TB
● Metric			
M3	1m	-5203K	258.00
M4	1m	-5204K	78.00
M5	1m	-5205K	78.00
M6	1m	-5206K	78.00
M8	1m	-5208K	129.00
M10	1m	-5210K	129.00
M12	1m	-5212K	191.00
M14	1m	-5214K	284.00
M16	1m	-5216K	294.00
M20	1m	-5220K	799.00
M24	1m	-5224K	876.00
M30	1m	-5230K	979.00
○ UNC			
1/4"	3ft	-5404K	155.00
5/16"	3ft	-5405K	258.00
3/8"	3ft	-5406K	309.00
7/16"	3ft	-5407K	361.00
1/2"	3ft	-5408K	515.00
5/8"	3ft	-5410K	670.00
3/4"	3ft	-5412K	1029.00
7/8"	3ft	-5414K	1545.00
1"	3ft	-5416K	1803.00

High Tensile Steel - Grade 8.8

Thread	Length	Order Code QFT-639	Price/1 TB
● Metric			
M6	1m	-6060K	88.00
M8	1m	-6080K	145.00
M10	1m	-6100K	201.00
M12	1m	-6120K	263.00
M16	1m	-6160K	464.00
M20	1m	-6200K	721.00
M24	1m	-6240K	979.00

Stainless Steel A2

Thread	Length	Order Code QFT-639	Price/1 TB
● Metric			
M3	1m	-7030K	258.00
M4	1m	-7040K	284.00
M5	1m	-7050K	294.00
M6	1m	-7060K	304.00
M8	1m	-7080K	567.00
M10	1m	-7100K	670.00
M12	1m	-7120K	721.00
M16	1m	-7160K	1236.00
M20	1m	-7200K	1659.00
M24	1m	-7240K	2833.00

High Tensile Steel - Grade 8.8 BZP

Thread	Length	Order Code QFT-639	Price/1 TB
● Metric			
M6	1m	-6406K	155.00
M8	1m	-6408K	258.00
M10	1m	-6410K	361.00
M12	1m	-6412K	464.00
M14	1m	-6414K	670.00
M16	1m	-6416K	876.00
M18	1m	-6418K	1082.00
M20	1m	-6420K	1236.00

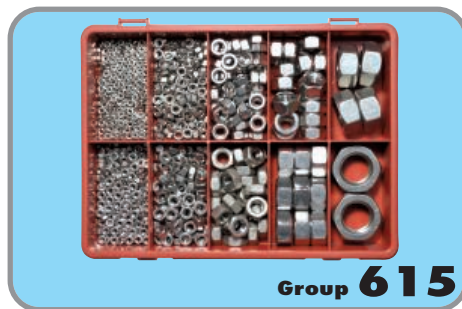

FASTENERS

Studding Connectors

Studding connectors or coupling nuts are for connecting multiple lengths of threaded rod. Made from low carbon steel, bright zinc-plated. Manufactured to **DIN 6334**.

Thread	Length	Weight each	Order Code QFT-639	Price/100 TB
M6	18mm	8g	-9906K	721.00
M8	24mm	28g	-9908K	1133.00
M10	30mm	40g	-9910K	2009.00
M12	36mm	56g	-9912K	2781.00
M16	48mm	113g	-9916K	6644.00
M20	60mm	160g	-9920K	12669.00
M24	72mm	224	-9924K	24205.00





QUALFAST Rivet Nuts

All of our rivet nuts have a clear plating which is RoHS compliant - this is now the preferred finish across all industries as there is no chromium content as is the case with zinc and yellow finish.

Steel, Low Profile Head, Splined Body

The splines on the body bite into the parent material on installation, creating an improved torque resistance compared with standard round bodied rivet nuts. The low profile head creates a high load bearing feature but only results in minimal stand off between the adjoining panels.

Size	Range (Grip)	Hole Size +0.1/-0.0	Dimensions				Box Qty	Order Code QFT-644	Price/Box TB
			D	H	P	L			
M4 x 0.7	0.5 - 2.0	6.8	5.9	6.9	0.4	10.0	500	-1004E	1494.00
M5 x 0.8	0.5 - 3.3	7.6	7.1	8.1	0.8	12.1	500	-1005F	1545.00
M6 x 1.0	0.7 - 4.2	10.0	9.5	10.4	0.8	15.1	250	-1006G	1391.00
M8 x 1.25	0.7 - 3.8	13.5	10.5	11.6	0.8	16.1	250	-1008J	1391.00

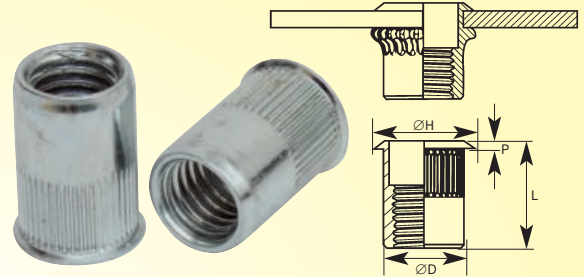

Steel, CSK Head, Splined Body

The splines on the body bite into the parent material on installation, creating an improved torque resistance compared with standard round bodied rivet nuts. The extra wide countersunk head provides excellent strength whilst leaving the nut flush with the material face.

Size	Range (Grip)	Hole Size +0.1/-0.0	Dimensions				Box Qty	Order Code QFT-644	Price/Box TB
			D	H	P	L			
M4	0.5 - 2.0	6.0	5.9	8.8	1.4	11.7	500	-1044Y	1597.00
M5	0.5 - 5.0	8.0	6.9	9.8	1.6	13.1	500	-1045Z	1597.00
M6	0.5 - 6.0	9.0	8.9	11.8	1.7	16.1	250	-1046A	1133.00
M8	3.5 - 9.0	11.0	10.9	13.7	2.0	18.6	250	-1048C	1494.00

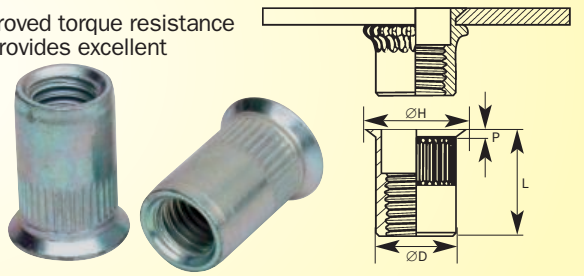

Steel, Flat Head, Splined Body

The splines on the body bite into the parent material on installation, creating an improved torque resistance compared with standard round bodied rivet nuts. The large flat head makes the fixing ideal for use in high load bearing situations.

Size	Range (Grip)	Hole Size +0.1/-0.0	Dimensions				Box Qty	Order Code QFT-644	Price/Box TB
			D	H	P	L			
M4 x 0.7	0.5 - 2.5	6.0	5.9	9.1	0.8	11.7	500	-1024B	1494.00
M5 x 0.8	0.7 - 3.0	7.0	6.9	10.0	1.0	13.1	500	-1025C	1597.00
M6 x 1.0	0.8 - 3.0	9.0	8.9	13.0	1.5	16.1	250	-1026D	1082.00
M8 x 1.25	1.0 - 3.0	11.0	10.9	14.8	1.5	18.1	250	-1028F	1494.00

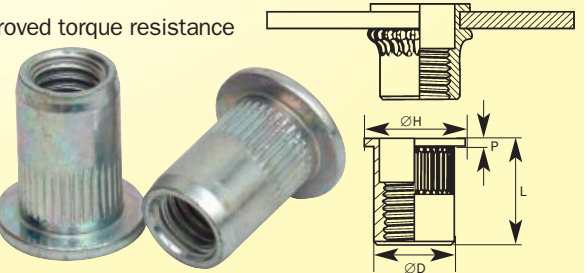

Aluminium Rivets

For all applications of blind riveting. Aluminium rivet head with steel mandrel. Medium strength, use with aluminium and where rust is a problem. Select grip based on thickness of material to be riveted.

EXTENDED RANGE

Dome Head



Head Ø mm	Length Below Shoulder	Box Qty	Order Code QFT-644	Price/1 TB
2.4	4mm	100	-2022Z	206.00
	6mm	100	-2026D	206.00
	8mm	100	-2030H	309.00
	5mm	100	-2042W	309.00
3.2	5mm	500	-2043X	979.00
	7mm	100	-2046A	309.00
	7mm	500	-2047B	979.00
	10mm	100	-2050E	309.00
	10mm	500	-2051F	979.00
	12mm	100	-2054E	309.00
	12mm	500	-2054M	979.00
	14mm	100	-2056E	309.00
	14mm	500	-2056M	979.00
	16mm	100	-2058E	309.00
16mm	500	-2058M	979.00	

Head Ø mm	Length Below Shoulder	Box Qty	Order Code QFT-644	Price/1 TB
4.0	6mm	100	-2062S	309.00
	6mm	500	-2063T	979.00
	8mm	100	-2065E	309.00
	8mm	500	-2065M	979.00
	10mm	100	-2066X	335.00
	10mm	500	-2067Y	1494.00
	12mm	100	-2070B	309.00
	12mm	500	-2071C	979.00
	14mm	100	-2074E	361.00
	14mm	500	-2074M	979.00
4.8	16mm	100	-2077E	387.00
	16mm	500	-2077M	979.00
	9mm	500	-2082P	1803.00
	9mm	50	-2083Q	155.00
	12mm	500	-2086T	1906.00
	12mm	50	-2087V	155.00
	14mm	50	-2089B	263.00
	14mm	250	-2089H	1303.00
	16mm	250	-2090Y	1200.00
	16mm	50	-2091Z	299.00
4.8	18mm	50	-2094B	320.00
	18mm	250	-2094H	1473.00

Dome Head Rivets - Bulk Packed



NEW

Head Ø mm	Length Below Shoulder	Box Qty	Order Code QFT-644	Price/1 TB
2.4	6mm	20000	-5106F	14673.00
	5mm	10000	-5125E	5835.00
	7mm	10000	-5127G	6026.00
3.2	10mm	10000	-5130K	6438.00
	12mm	10000	-5132M	6953.00
	14mm	10000	-5134P	7705.00
	16mm	10000	-5136R	8215.00
4.0	10mm	8000	-5160A	7262.00
	12mm	8000	-5162C	7705.00
4.8	9mm	5000	-5189H	6438.00
	12mm	5000	-5192B	6850.00
4.8	16mm	4000	-5196F	6515.00

Large Head



Head Ø mm	Length Below Shoulder	Box Qty	Order Code QFT-644	Price/1 TB
3.2	8mm	50	-5032K	284.00
	8mm	500	-5033L	1494.00
	12mm	50	-5036P	284.00
	12mm	500	-5037Q	1494.00
	16mm	50	-5040T	309.00
	16mm	500	-5041V	1803.00
4.0	10mm	50	-5052G	361.00
	10mm	250	-5053H	1082.00
	12mm	50	-5056L	361.00
	12mm	250	-5057M	1133.00
	16mm	25	-5060Q	258.00
	16mm	250	-5061R	1288.00
4.8	12mm	25	-5072D	361.00
	12mm	250	-5073E	1494.00
	16mm	20	-5076H	258.00
	16mm	100	-5077J	824.00
	20mm	20	-5080M	258.00
	20mm	100	-5081N	824.00

Countersunk



Head Ø mm	Length Below Shoulder	Box Qty	Order Code QFT-644	Price/1 TB
3.2	8mm	100	-1132K	194.00
	8mm	500	-1133L	658.00
	12mm	100	-1136P	232.00
	12mm	500	-1137Q	735.00
4.0	15mm	100	-1140T	252.00
	15mm	500	-1141V	773.00
	10mm	100	-1152G	271.00
	10mm	500	-1153H	850.00
	12mm	100	-1156L	309.00
4.8	12mm	500	-1157M	967.00
	16mm	50	-1160Q	194.00
	16mm	500	-1161R	1044.00
	12mm	50	-1172D	271.00
	12mm	500	-1173E	850.00
	16mm	50	-1176H	232.00
4.8	16mm	250	-1177J	735.00
	20mm	50	-1180M	271.00
	20mm	250	-1181N	850.00

FASTENERS

PRODUCTS ARE ONLY AVAILABLE VIA YOUR DISTRIBUTOR

GROUP 649/650 CIRCLIPS/DOWEL PINS

QUALFAST Circlips

Circlips simplify designs and linked with lower installation costs are the ideal item for replacing more traditional fasteners. Manufactured from carbon steel with a phosphate finish.

External



External DIN 471

Metric			
Dia. (mm)	Pack Quantity	Order Code QFT-649	Price/Pack TB
3	100	-2003C	170.00
4	100	-2004D	170.00
5	100	-2005E	170.00
6	100	-2006F	181.00
7	100	-2007G	181.00
8	50	-2008H	181.00
9	50	-2009J	191.00
10	50	-2010K	191.00
11	50	-2011L	191.00
12	50	-2012M	201.00
13	50	-2013N	201.00
14	50	-2014P	201.00
15	50	-2015Q	222.00
16	40	-2016R	222.00
17	40	-2017S	222.00
18	25	-2018T	232.00
19	25	-2019V	232.00
20	25	-2020W	232.00
24	25	-2024Y	258.00
25	25	-2025A	258.00
26	25	-2026B	258.00
27	25	-2027C	258.00
28	25	-2028D	309.00
29	25	-2029E	309.00
30	25	-2030F	309.00

Internal



Internal DIN 472

Metric			
Dia. (mm)	Pack Quantity	Order Code QFT-649	Price/Pack TB
8	50	-2208H	114.00
9	50	-2209J	114.00
10	50	-2210K	114.00
11	50	-2211L	124.00
12	50	-2212M	124.00
13	50	-2213N	134.00
14	50	-2214P	134.00
15	50	-2215Q	134.00
16	40	-2216R	145.00
17	40	-2217S	145.00
18	25	-2218T	145.00
19	25	-2219V	155.00
20	25	-2220W	170.00
21	25	-2221X	176.00
22	25	-2222Y	186.00
23	25	-2223Z	186.00
24	25	-2224A	196.00
25	25	-2225B	196.00
26	25	-2226C	196.00
27	25	-2227D	196.00
28	25	-2228E	206.00
29	25	-2229F	206.00
30	25	-2230C	206.00

E-Clips



E-clips simplify designs and linked with lower installation costs are the ideal item for replacing more traditional fasteners. All are manufactured from carbon steel with a phosphate finish. Conform to DIN 6799.



Metric			
Dia. (mm)	Pack Quantity	Order Code QFT-649	Price/Pack TB
1.2	200	-3992P	161.00
1.5	200	-3995S	250.00
1.9	200	-3998W	335.00
2.3	200	-4001A	129.00
3.2	200	-4003C	255.00
4.0	100	-4004D	164.00
5.0	100	-4005E	182.00
6.0	100	-4006F	190.00
7.0	100	-4007G	225.00
8.0	50	-4008H	225.00
9.0	25	-4009J	143.00
10.0	25	-4010K	156.00
12.0	25	-4012M	156.00

KENNEDY Extractable Dowels

Extractable dowel pins complete with inner thread and slight flats for air release.

DIN 7979D. EN 28735. ISO 8735.

Material:

AISI-52100 or DIN 1-3505 100 Cr 6.

Hardness: 57-63 HRC.



Metric				
Dia.	Length	Weight per 100	Order Code KEN-651	Price/100 TB
4	10	100g	-0650K	5732.00
	12	130g	-0660K	5732.00
	16	160g	-0680K	5928.00
	20	100g	-0700K	6637.00
	30	130g	-0720K	6903.00
	12	160g	-0820K	3089.00
5	16	180g	-0840K	3089.00
	20	200g	-0860K	1863.00
	24	300g	-0880K	2235.00
	30	330g	-0910K	2235.00
	40	330g	-0950K	7379.00
	50	410g	-0970K	7379.00
60	510g	-0980K	12207.00	
6	12	120g	-1000K	13268.00
	16	150g	-1020K	1174.00
	20	180g	-1040K	1174.00
	24	220g	-1060K	1236.00
	25	240g	-1080K	1386.00
	28	260g	-1100K	1386.00
8	30	270g	-1120K	1386.00
	32	290g	-1140K	3454.00
	36	310g	-1160K	1442.00
	40	350g	-1180K	1448.00
	45	400g	-1200K	1808.00
	50	440g	-1220K	1808.00
10	60	540g	-1240K	3096.00
	16	270g	-1420K	1911.00
	20	320g	-1440K	1911.00
	24	390g	-1460K	1499.00
	25	400g	-1480K	1911.00
	28	430g	-1500K	1551.00
12	30	470g	-1520K	1293.00
	32	500g	-1540K	1602.00
	36	550g	-1560K	1339.00
	40	630g	-1580K	1545.00
	45	710g	-1600K	1911.00
	50	790g	-1620K	2014.00
15	60	910g	-1640K	2581.00
	70	990g	-1660K	3044.00
	80	1200g	-1680K	3044.00

Dia.	Length	Weight per 100	Order Code KEN-651	Price/100 TB
10	20	490g	-1840K	1808.00
	24	620g	-1860K	1551.00
	25	640g	-1880K	1963.00
	28	680g	-1900K	1963.00
	30	740g	-1920K	1963.00
	32	800g	-1940K	2581.00
	35	840g	-1950K	2581.00
	36	860g	-1960K	2581.00
	40	1.00kg	-1980K	2581.00
	45	1.09kg	-2000K	2581.00
	50	1.27kg	-2020K	2581.00
	60	1.45kg	-2040K	2581.00
12	70	1.72kg	-2060K	3302.00
	80	2.00kg	-2080K	3611.00
	90	2.27kg	-2100K	6958.00
	100	2.82kg	-2120K	7988.00
	24	900g	-2460K	4074.00
	25	1.00kg	-2480K	4126.00
	30	1.09kg	-2520K	3611.00
	32	1.17kg	-2540K	3868.00
	36	1.27kg	-2560K	3868.00
	40	1.45kg	-2580K	3971.00
	45	1.63kg	-2600K	3971.00
	50	1.81kg	-2620K	4074.00
16	60	2.18kg	-2640K	4126.00
	70	2.45kg	-2660K	4383.00
	80	2.81kg	-2680K	4795.00
	90	3.18kg	-2700K	6031.00
	100	3.54kg	-2720K	13653.00
	30	800g	-3120K	9785.00
	32	1.00kg	-3140K	10300.00
	36	1.16kg	-3160K	10300.00
	40	1.26kg	-3180K	10306.00
	45	1.42kg	-3200K	10821.00
	50	1.58kg	-3220K	10821.00
	60	1.90kg	-3240K	11078.00
70	2.20kg	-3260K	11336.00	
80	2.50kg	-3280K	11593.00	
20	90	2.90kg	-3300K	11645.00
	100	3.15kg	-3320K	11851.00
	40	1.58kg	-3580K	11851.00
	50	1.98kg	-3620K	12881.00
	60	2.38kg	-3640K	12881.00
	70	2.75kg	-3660K	13905.00
25	80	3.13kg	-3680K	15971.00
	90	3.62kg	-3700K	16995.00
	100	3.94kg	-3720K	18025.00
	50	5.10kg	-3920K	18540.00

Steel Balls

Low carbon case hardened steel balls are for general use in castors, conveyors, non-precision bearings and any slow rotating parts. They have resistance to shock loads with a good load carrying ability and excellent resistance to surface wear. The G100 standard ball is of a high spherical standard.



Diameter	Pack Qty	Weight	Order Code QFT-671	Price/Pk TB
Metric				
2mm	100	4g	-1002B	205.00
3mm	50	6g	-1003C	206.00
4mm	50	18g	-1004D	232.00
5mm	50	26g	-1005E	258.00
6mm	50	44g	-1006F	258.00
7mm	50	70g	-1007R	308.00
8mm	25	55g	-1008G	308.00
10mm	25	105g	-1010J	411.00
12mm	10	71g	-1012L	361.00
16mm	10	168g	-1016Q	514.00
20mm	10	327g	-1020S	617.00

FASTENERS



KENNEDY Quality Industrial
QUALITY INDUSTRIAL TOOLING® **Dowel Pins**

Hardened and precision ground. Conform with **DIN 6325**. **Metric:** Sizes 3mm are manufactured from non-hardened silver steel, 4mm and above are high quality through hardened mild steel.

Tolerances:

- 3mm = +0.002
- +0.008
- 4 - 6mm = +0.004
- +0.012
- 8 - 10mm = +0.006
- +0.0015
- 12 - 16mm = +0.007
- +0.0018.

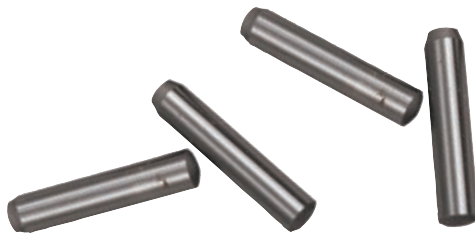

Sizes 1/16" and 1/8" are manufactured from non-hardened silver steel, 3/16" and above are high quality case hardened mild steel.

Tolerances:

All sizes = +0.001" +0.003".

Metric				
Dia. (mm)	Length mm	Weight per 100	Order Code KEN-650	Price/100 TB
2	6	34g	-0500K	320.00
	8	100g	-0520K	325.00
	10	125g	-0530K	263.00
2.5	6	36g	-0580K	567.00
	8	38g	-0600K	567.00
	10	40g	-0620K	670.00
	12	45g	-0640K	377.00
3	6	110g	-0860K	338.00
	8	120g	-0880K	338.00
	10	130g	-0900K	325.00
	12	140g	-0920K	351.00
	14	145g	-0930K	362.00
	16	150g	-0940K	606.00
	18	165g	-0950K	606.00
	20	180g	-0960K	431.00
	24	188g	-0970K	876.00
	25	190g	-0980K	441.00
	28	200g	-0990K	478.00
	30	210g	-0995K	425.00
40	300g	-1040K	669.00	
4	6	75g	-1060K	298.00
	8	87g	-1080K	298.00
	10	100g	-1100K	325.00
	12	150g	-1120K	335.00
	14	200g	-1130K	362.00
	16	220g	-1140K	377.00
	18	230g	-1150K	616.00
	20	240g	-1160K	616.00
	24	280g	-1170K	446.00
	25	300g	-1180K	446.00
	28	307g	-1190K	500.00
	30	310g	-1200K	590.00
5	32	330g	-1210K	590.00
	36	405g	-1230K	600.00
	40	410g	-1240K	669.00
	10	200g	-1310K	404.00
	12	220g	-1320K	404.00
	16	300g	-1340K	478.00
	18	350g	-1350K	478.00
	20	400g	-1360K	531.00
	24	420g	-1370K	590.00
	25	420g	-1380K	606.00
	30	500g	-1400K	696.00
	32	540g	-1410K	802.00
35	600g	-1420K	999.00	
36	620g	-1430K	1009.00	
40	640g	-1440K	802.00	
50	800g	-1460K	1704.00	

Metric . . . continued					
Dia. (mm)	Length mm	Weight per 100	Order Code KEN-650	Price/100 TB	
6	10	410g	-0151K	464.00	
	12	430g	-1520K	691.00	
	14	450g	-1530K	691.00	
	16	470g	-1540K	537.00	
	18	480g	-1550K	537.00	
	20	500g	-1560K	829.00	
	24	530g	-1570K	585.00	
	25	600g	-1580K	643.00	
	28	660g	-1590K	696.00	
	30	700g	-1600K	637.00	
	32	740g	-1610K	955.00	
	35	800g	-1620K	723.00	
	36	820g	-1630K	987.00	
	40	900g	-1640K	775.00	
	50	1.10kg	-1680K	881.00	
	60	1.40kg	-1720K	961.00	
	8	16	700g	-1840K	606.00
		18	740g	-1850K	669.00
20		780g	-1860K	669.00	
24		960g	-1870K	696.00	
25		1.00kg	-1880K	2059.00	
28		1.10kg	-1890K	2059.00	
30		1.20kg	-1900K	2059.00	
32		1.28kg	-1910K	2070.00	
35		1.40kg	-1920K	2228.00	
36		1.40kg	-1930K	2334.00	
40		1.60kg	-1940K	2441.00	
45		1.80kg	-1960K	2547.00	
10	50	2.00kg	-1980K	2653.00	
	60	2.30kg	-2020K	2653.00	
	70	2.50kg	-2040K	2653.00	
	80	3.00kg	-2080K	2653.00	
	20	1.30kg	-2160K	1189.00	
	24	1.60kg	-2170K	1120.00	
	25	1.60kg	-2180K	1120.00	
	28	1.90kg	-2190K	1288.00	
	30	1.90kg	-2200K	1174.00	
	32	2.00kg	-2210K	1174.00	
	35	2.20kg	-2220K	1174.00	
	36	2.28kg	-2230K	1442.00	
	40	2.50kg	-2240K	1494.00	
	45	2.80kg	-2260K	1602.00	
	50	3.20kg	-2280K	1602.00	
	60	37.0kg	-2320K	1656.00	
	70	4.30kg	-2340K	2838.00	
	80	5.00kg	-2360K	3096.00	
90	5.70kg	-2380K	5104.00		
100	7.10kg	-2400K	4795.00		
12	20	2.20kg	-2460K	2272.00	
	24	2.30kg	-2470K	2272.00	
	25	2.30kg	-2480K	2272.00	
	28	2.65kg	-2490K	2272.00	
	30	2.80kg	-2500K	2272.00	
	32	3.00kg	-2510K	2272.00	
	35	3.20kg	-2520K	2375.00	
	36	3.20kg	-2530K	3605.00	
	40	7.30kg	-2540K	2578.00	
	45	4.10kg	-2560K	2036.00	
	50	4.60kg	-2580K	2685.00	
	60	5.50kg	-2620K	2907.00	
	70	6.20kg	-2640K	3860.00	
	80	7.10kg	-2660K	3874.00	
	90	8.00kg	-2680K	6957.00	
	100	8.90kg	-2700K	6957.00	
	16	32	5.00kg	-2800K	3199.00
		36	5.60kg	-2820K	3199.00
40		6.30kg	-2840K	3863.00	
45		7.10kg	-2860K	3914.00	
50		7.90kg	-2880K	4017.00	
60		9.50kg	-2920K	6179.00	
70		11.00kg	-2940K	6438.00	
80		12.00kg	-2960K	6695.00	
100		15.80kg	-3000K	7725.00	

Inch				
Dia. (mm)	Length mm	Weight per 100	Order Code KEN-650	Price/100 TB
1/8"	1/4"	110g	-4620K	529.00
	3/8"	120g	-4660K	563.00
	1/2"	130g	-4700K	542.00
	5/8"	140g	-4740K	563.00
	3/4"	150g	-4760K	563.00
	1"	200g	-4800K	829.00
3/16"	1 1/2"	300g	-4880K	855.00
	2"	600g	-4960K	961.00
	1/2"	280g	-5500K	425.00
	5/8"	300g	-5540K	510.00
	3/4"	400g	-5560K	643.00
	1"	500g	-5600K	531.00
1/4"	1 1/4"	550g	-5640K	574.00
	1 1/2"	600g	-5680K	723.00
	2"	800g	-5760K	749.00
	1/2"	400g	-6300K	563.00
	5/8"	500g	-6340K	510.00
	3/4"	550g	-6360K	510.00
5/16"	1"	700g	-6400K	567.00
	1 1/4"	820g	-6440K	1530.00
	1 1/2"	1.10kg	-6480K	1547.00
	2"	1.40kg	-6560K	1942.00
	1/2"	600g	-6850K	1404.00
	3/4"	800g	-6860K	2781.00
3/8"	1"	1.20kg	-6900K	1530.00
	1 1/4"	1.40kg	-6940K	1547.00
	1 1/2"	1.60kg	-6980K	1905.00
	2"	2.20kg	-7060K	2583.00
	2 1/2"	2.80kg	-7140K	2775.00
	3"	3.20kg	-7220K	4178.00
1/2"	3 1/2"	3.90kg	-7300K	4730.00
	5/8"	1.10kg	-7420K	2704.00
	3/4"	1.30kg	-7460K	1655.00
	1"	1.60kg	-7500K	1705.00
	1 1/4"	2.10kg	-7540K	2001.00
	1 1/2"	2.40kg	-7580K	2238.00
5/8"	1 3/4"	2.80kg	-7620K	2365.00
	2"	3.10kg	-7660K	2823.00
	2 1/2"	3.90kg	-7740K	3672.00
	3"	4.60kg	-7820K	4569.00
	3 1/2"	5.80kg	-7900K	5330.00
	5/8"	1.80kg	-8060K	2062.00
3/4"	3/4"	2.30kg	-8080K	2775.00
	1"	3.00kg	-8100K	2369.00
	1 1/4"	3.70kg	-8140K	2859.00
	1 1/2"	4.10kg	-8180K	3390.00
	1 3/4"	4.80kg	-8220K	5237.00
	1/2"	2"	6.00kg	-8260K
1"	2 1/4"	6.10kg	-8300K	3954.00
	2 1/2"	6.80kg	-8340K	4998.00
	2 3/4"	12.20kg	-8380K	5495.00
	3"	8.00kg	-8420K	6757.00
	3 1/2"	9.30kg	-8480K	11300.00
	4"	10.70kg	-8520K	11867.00
5/8"	1"	5.00kg	-8680K	3355.00
	1 1/4"	6.80kg	-8700K	3703.00
	2"	8.60kg	-8760K	5736.00
	3"	12.20kg	-8920K	9528.00
	3 1/2"	14.60kg	-8960K	11186.00
	4"	16.30kg	-9000K	11867.00
3/4"	1 1/2"	9.20kg	-9160K	6020.00
	2"	10.04kg	-9180K	7155.00
	4"	15.20kg	-9280K	16070.00
	3"	18.20kg	-9940K	10448.00

PRODUCTS ARE ONLY AVAILABLE VIA YOUR DISTRIBUTOR

GROUP 662 HOSE CLIPS

MATLOCK Zinc-Plated Hose Clips BZP

Non-slip worm drive. Precision manufactured from the finest steel to **DIN 3017**. Passivated zinc finish to give double protection. For automotive, gas, plumbing and agricultural applications.



ZINC-PLATED

Size	Capacity (mm)	Order Code MTL-662	Price/100 TB
000	8-12	-5050K	1494.00
M00	10-16	-5070K	1198.00
00	12-20	-5090K	1198.00
0	12-22	-5110K	1545.00
OX	16-27	-5130K	1545.00
1A	20-32	-5150K	1648.00
1	23-35	-5160K	1751.00
1X	25-40	-5170K	1854.00
2A	32-50	-5190K	1906.00
2	40-55	-5210K	1957.00
2X	40-60	-5230K	2059.00
3	50-70	-5250K	2163.00
3X	60-80	-5270K	2266.00
4	70-90	-5290K	2369.00
4X	80-100	-5310K	2472.00
5	90-110	-5330K	2575.00
6	110-120	-5350K	2918.00
6X	120-140	-5370K	2936.00

Zinc-Plated Hose Clip Sets

50 piece set contains sizes 000 to size 2X. (8mm to 60mm dia.). 4 x 000 - quantities as below. **100 piece set contains double these quantities.**

4 x 000	3 x 1A	2 x 2X	1 x 5
4 x M00	5 x 1	2 x 3	1 x 6
6 x 00	3 x 1X	1 x 3X	1 x 6X
4 x 0	2 x 2A	2 x 4	1 x 7
3 x OX	3 x 2	1 x 4X	1 x 8



ZINC-PLATED

Number of Pieces	Weight each	Order Code MTL-662	Price/1 TB
50	1.50kg	-5950K	670.00
100	3.00kg	-5990K	1803.00

Hose Clip Service Set

Manufactured from zinc-plated mild steel. Supplied in service case with Flex-Driver.

- 30 x 000
- 30 x M00
- 25 x 0
- 25 x OX
- 12 x 1A
- 12 x 1X
- 6 x 2A



NEW

No. of Pieces	Order Code MTL-662	Price/1 TB
140	-6000K	3683.00

Hose Clip Flex-Driver

Bends through 90° to reach otherwise inaccessible clips. High impact Hi Grip handle. Drive shaft has 1/4" hex drive fitted with 7mm (single hex) removable adaptor. Also features swivel collar at drive end.



Length (mm)	Weight each	Order Code MTL-662	Price/1 TB
280	160g	-9990K	205.00

Stainless Steel Hose Clips

Clamps incorporate rolled band edges that won't cut hose, stamped threads for uniform tensioning and one-piece stamped worm housing for superior strength. Precision manufactured from the finest steel to **DIN 3017**.



STAINLESS STEEL

Size	Capacity (mm)	Order Code MTL-662	Price/100 TB
000	8-12	-4050K	3926.00
M00	10-16	-4070K	4017.00
00	12-20	-4090K	4085.00
0	12-22	-4110K	4775.00
OX	16-27	-4130K	5665.00
1A	20-32	-4150K	5517.00
1	23-35	-4160K	5623.00
1X	25-40	-4170K	5729.00
2A	32-50	-4190K	5835.00
2	40-55	-4210K	6048.00
2X	40-60	-4230K	6207.00

Stainless Steel Hose Clip Set

Contains sizes 000 to size 2X. (8mm to 60mm dia.).

STAINLESS STEEL

4 x 000	6 x 0	5 x 1	3 x 2X
4 x M00	5 x OX	4 x 1X	
8 x 00	4 x 1A	3 x 2A	



Number of Pieces	Weight each	Order Code MTL-662	Price/1 TB
50	700g	-5960K	2685.00

Quick Release Stainless Steel Hose Clips

STAINLESS STEEL

Easy to fit, quick clamps. The swivel-action locking of screw band makes both installation and removal fast and easy. ideal for use in difficult positions and applications. Precision manufactured from the finest steel to **DIN 3017**.

Band and Housing Material: 210/301. **Stainless Steel Screw:** 5/16" Hex-Head 410.



NEW

Capacity (mm)	Order Code MTL-662	Price/100 TB
25-101	-6020K	5500.00
44-178	-6040K	6500.00
44-217	-6060K	7000.00
44-406	-6080K	9999.00
44-559	-6100K	15000.00
51-127	-6120K	7500.00
51-254	-6140K	9500.00
52-152	-6160K	8500.00
52-312	-6180K	12500.00
355-508	-6300K	15500.00
362-457	-6320K	16500.00

Nut & Bolt Clips

ZINC-PLATED

'Junior' Style

Mild zinc protected nut and bolt clips. Ideal for use on petrol pipes and small bore hoses. 7mm A/F screw, 1.2Nm maximum tightening torque.



Size	Capacity (mm)	Order Code MTL-662	Price/100 TB
J09	7-9	-8060K	1332.00
J10	8-10	-8070K	1332.00
J11	9-11	-8080K	1332.00
J12	10-12	-8090K	1332.00
J13	11-13	-8100K	1332.00
J14	12-14	-8110K	1332.00
J15	13-15	-8120K	1438.00
J16	14-16	-8130K	1438.00
J17	15-17	-8140K	1438.00
J18	16-18	-8150K	1438.00

Nut & Bolt Clips Sets

Assorted clip sets. **Capacity:** 7 to 20mm.

Number of Pieces	Order Code MTL-662	Price/1 TB
65	-8180K	1417.00
160	-8190K	2575.00

Heavy Duty Bolt Clamps

'Super' Style

Heavy duty bolt clamps to **DIN 3017** are specifically designed to give extremely high band tension for sealing pressure/suction lines with either steel or plastic reinforcement and high shore hardness. Reinforced loops withstand significantly higher torques and the mechanically locked closure has no welding points and therefore no contact corrosion. Bridge gives optimal hose protection and the robust band with rounded edges for protection against injuries and/or damage to the hose surface. W2 material. Band grade 430 stainless steel. Housing/bolt 8.8 grade BZP.



Size	Capacity (mm)	Order Code MTL-662	Price/100 TB
S19	17-19	-9010K	5888.00
S22	20-22	-9020K	5931.00
S25	23-25	-9030K	5992.00
S28	26-28	-9040K	6070.00
S31	29-31	-9050K	6173.00
S35	32-35	-9060K	6295.00
S39	36-39	-9070K	6459.00
S43	40-43	-9080K	6667.00
S47	43-47	-9090K	6891.00
S51	47-51	-9100K	7177.00
S55	51-55	-9110K	7548.00
S59	55-59	-9120K	8353.00
S63	59-63	-9130K	8413.00
S68	63-68	-9140K	8533.00
S73	68-73	-9150K	8741.00
S79	73-79	-9160K	9009.00
S85	79-85	-9170K	9337.00
S91	85-91	-9180K	13254.00
S97	91-97	-9190K	13505.00
S104	97-104	-9200K	13884.00
S112	104-112	-9210K	14395.00
S121	112-121	-9220K	15061.00
S130	121-130	-9230K	16098.00
S140	130-140	-9240K	17369.00
S150	140-150	-9250K	18847.00
S162	150-162	-9260K	20638.00
S174	162-174	-9270K	22980.00
S187	174-187	-9280K	23291.00
S200	187-200	-9290K	23722.00
S213	200-213	-9300K	24889.00
S226	213-226	-9310K	26515.00
S239	226-239	-9320K	28434.00
S252	239-252	-9330K	30889.00

FASTENERS

MATLOCK

O-Clips

Manufactured from zinc-plated mild steel. Medium pressure clamp, widely used for maintenance and OEM applications. Rubber hose, plastic tubing, coaxial and electrical cable are easily clamped. Suitable for use on air, fluid, gas and steam lines also low pressure hydraulics applications. One-piece design offers a positive, tamperproof seal without damage to the hose, assure adequate closure and compensate for tolerance variations in hose sizes.

Pack quantity: 100.

Twin Ear



EXTENDED RANGE



Single Ear

N.B. Gas hoses should only be assembled by professionally qualified fitters

Size	Capacity (mm)	Order Code MTL-662	Price/100 TB
Twin Ear Style			
9T	7 - 9	-7060K	608.00
11T	8 - 11	-7070K	926.00
13T	11 - 13	-7090K	842.00
15T	13 - 15	-7100K	1119.00
18T	15 - 18	-7120K	950.00
20T	17 - 20	-7140K	999.00
23T	20 - 23	-7160K	1133.00

Size	Capacity (mm)	Order Code MTL-662	Price/100 TB
Single Ear Style			
9S	7 - 9	-6920K	907.00
10S	8 - 10	-6930K	907.00
11S	9 - 11	-6940K	907.00
12S	10 - 12	-6950K	907.00
13S	11 - 13	-6960K	1020.00
14S	12 - 14	-6970K	1247.00
16S	14 - 16	-6980K	1417.00
18S	16 - 18	-6990K	1643.00

Welding Hose Clip Sets

Manufactured from zinc-plated mild steel.

75 Piece
Size range: 9T to 18T



165 Piece with Pincers
Size range: 13T to 20T



NEW

No. of Pieces	Order Code MTL-662	Price/1 TB
75	-7200K	1545.00
165	-7210K	3089.00

KENNEDY O-Clip Pincers

O-clip pincers are designed for rapidly closing O-clips ensuring a positive tamperproof seal. Manufactured from chrome vanadium steel with induction hardened, ground and polished jaws. Bonded vinyl-coated handle.

Overall length: 200mm.



NEW

Length (mm)	Order Code KEN-558	Price/1 TB
200	-1000K	773.00

Rubber-Lined P-Clips

All clips lined in EPM rubber which is fully resilient to oils and extreme temperatures (-50°C to 160°C). Applications include automotive engine compartment and chassis, electrical cables, pipework, ducting, refrigeration and machine installations.

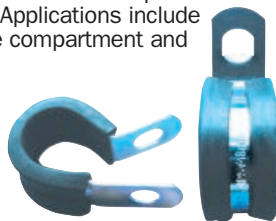

Capacity (mm)	Order Code MTL-662	Price/100 TB
Mild Steel - Zinc-Plated		
4	-8520K	1599.00
5	-8530K	1664.00
6	-8540K	1727.00
8	-8550K	1871.00
10	-8560K	2424.00
13	-8570K	2743.00
16	-8580K	2979.00
19	-8590K	3287.00
21	-8600K	3451.00
22	-8610K	3607.00
25	-8620K	4175.00
27	-8630K	4722.00
30	-8640K	4800.00
32	-8650K	4961.00
35	-8660K	5135.00
38	-8670K	6637.00
40	-8680K	7680.00
Stainless Steel		
5	-8830K	3648.00
6	-8840K	3682.00
8	-8850K	3892.00
10	-8860K	4022.00
13	-8870K	4218.00
16	-8880K	4462.00
18	-8890K	4888.00
20	-8900K	5047.00
21	-8910K	5232.00
22	-8920K	5339.00
25	-8930K	5634.00
28	-8940K	5935.00
30	-8950K	6095.00
32	-8960K	6303.00
34	-8970K	6481.00
38	-8980K	6846.00
40	-8990K	6500.00

Terry Type Spring Clips BZP

High quality spring steel clips with bright zinc plated finish (BZP). Ideal for securing tools, pipes etc.

Pack quantity: 100.



Size	Capacity (mm)	Order Code MTL-662	Price/100 TB
Open Type			
T1	6	-1000K	680.00
T2	10	-1010K	680.00
T3	12	-1020K	737.00
T4	16	-1030K	907.00
T5	20	-1040K	907.00
T6	25	-1050K	1190.00
T7	32	-1060K	1983.00
T8	38	-1070K	2720.00
T9	50	-1080K	3739.00
Closed Type			
C1	6	-2100K	624.00
C2	10	-2110K	680.00
C3	12	-2120K	680.00
C4	16	-2130K	850.00
C5	20	-2140K	907.00
C6	25	-2150K	1020.00
C7	32	-2160K	1360.00
C8	38	-2170K	1803.00
C9	50	-2180K	3456.00

Assorted Packs

Type	No. of Pieces	Order Code MTL-662	Price/1 TB
Open	160	-1180K	2059.00
Closed	124	-2280K	2720.00

MATLOCK

Saddle Clamps



Widely used for fixing pipes and cables in all industries.

Half Saddle Clamps - Heavy Duty
DIN1596.

NEW



Type	Size (mm)	Order Code MTL-662	Price/100 TB
1-Pipe	7	-7700K	1757.00
	9	-7710K	2153.00
	13	-7720K	2606.00
	15.5	-7730K	2890.00
	19	-7740K	3230.00
	23	-7750K	6289.00
	26	-7760K	6855.00
	28.5	-7770K	7308.00
	31	-7780K	7988.00
	33	-7790K	9404.00

Twin Saddle Clamps
DIN72572.

NEW



Size (mm)	Order Code MTL-662	Price/100 TB
5	-7850K	1077.00
6	-7860K	1077.00
7	-7870K	1247.00
8	-7880K	1303.00
10	-7890K	1303.00
12	-7900K	1473.00
15	-7910K	1757.00
18	-7920K	1932.00
20	-7930K	2097.00
22	-7940K	1473.00

Half Saddle Clamps - Light Duty
DIN72571.

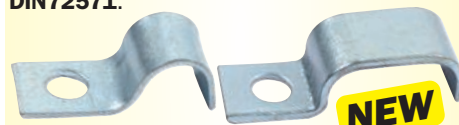

Type	Size (mm)	Order Code MTL-662	Price/100 TB
1-Pipe	4	-7300K	794.00
	5	-7310K	850.00
	6	-7320K	907.00
	7	-7330K	964.00
	8	-7340K	1020.00
	10	-7350K	1190.00
	12	-7360K	1473.00
	16	-7370K	1643.00
	2-Pipe	4	-7400K
5		-7410K	1303.00
6		-7420K	1700.00
7		-7430K	1473.00
8		-7440K	1587.00
10		-7450K	1757.00
12	-7460K	2210.00	

Full Saddle Clamps - Light Duty
DIN72573.

NEW



Type	Size (mm)	Order Code MTL-662	Price/100 TB
1-Pipe	4	-7470K	1247.00
	5	-7480K	1360.00
	6	-7490K	1530.00
	7	-7500K	1587.00
	8	-7510K	1700.00
	10	-7520K	1757.00
	12	-7530K	1932.00
	15	-7540K	1932.00
	18	-7550K	2040.00
	20	-7560K	2097.00
	22	-7570K	2210.00
	2-Pipe	4	-7600K
5		-7610K	1417.00
6		-7620K	1530.00
8		-7630K	1757.00
10		-7640K	1906.00



GROUP 721 **PAINTS**



Page **647**

GROUP 725 **ADHESIVES**



Page **647**

GROUP 708 **HOT DIP**



Page **646**

GROUP 716 **SEALANTS & FILLERS**



Page **646**

GROUP 726 **'O' RINGS**



Page **648**

GROUP 727 **DEGREASERS**



Page **648**

GROUP 732 **CLEANERS & SOLVENTS**



Page **650**

GROUP 732 **MAINTENANCE SPRAYS & LUBRICANTS**



Page **649 - 656**

GROUP 732 **WELDER'S ANTI-SPATTER**



Page **655**

GROUP 732 **AUTOMOTIVE MAINTENANCE & REPAIR**



Page **649**

GROUP 732 **TAPPING & DRILLING LUBRICANTS**



Page **652**

GROUP 734 **MARKERS - LINE & PAINT**



Page **657**

GROUP 740 **METAL WORKING LUBRICANTS**



Page **660 - 661**

GROUP 740 **FOOD SAFE LUBRICANTS & CLEANERS**



Page **658 - 659**



LUBRICANTS & CHEMICAL PRODUCTS

**Product Groups
703 - 742**

Product Grading



Production

High performance industrial tooling designed for continuous use applications on machine tools where repeatability and long tool life are of critical importance.



Professional

Industrial tooling that has enhanced features and benefits demanded by craftsmen and professional users.



Industrial

Designed for regular use in industrial applications. Manufactured to stringent quality levels and international standards.



Workshop

Standard quality tooling for use by tradesmen and generally industrial use.



Maintenance

Products designed for general maintenance of machines, workshops, garages and some household applications.



Home Improver

DIY quality tooling. Designed for home use and light industrial applications.

Contents

Description	Group	Page
Adhesives - Instant	725	647
- Spray	725	647
- Structural	725	647
Automotive Maintenance & Repair	732	649
Cartridge Applicator Guns	715	646
Chain, Drive & Rope Lubricants	732	651
Degreasers	727	648
Food Safe Oils & Greases	740	658 - 659
Hot Dips Coatings	708	646
Hydraulic Oils	740	660 - 661
Industrial Cleaners & Solvents	732	650
Leak Detectors, Flawfinders & Freezer Sprays	732	654
Lubricating & Penetrating Oils	732	653
Markers - Line	734	657
- Paint	734	657
Melting Pots	709	646
Metal Working Lubricants	740	660 - 661
Mould Release Agents	732	656
Paints	721	647
Sealants & Fillers	716	646
Tapping & Drilling Lubricants	732	652

KENNEDY
QUALITY INDUSTRIAL TOOLING

**Protective Coating
Red-Hot-Dip**

Hot dip strippable plastic coating moulds itself around the component or tool being coated to provide 100% coverage and protects against corrosion and impacts, for up to ten years. The component protected can be easily identified through the translucent coating. Simply removed by peeling it off, leaves behind a thin oil film to provide short term protection against corrosion. The removed protective dip can be reused. Never directly apply heat to melt the protective dip, always use with a suitable melting pot. Working temperature 130°C to 160°C (for optimum results 140°C to 145°C).

RD160
Red

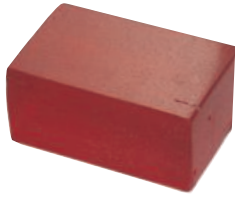

AD160
Amber



Description (Bars)	Weight each	Order Code KEN-708	Price/1 TB
RD160 Single Bar	0.50kg	-0050K	466.00
RD160 Case (50)	25.00kg	-0250K	19861.00
AD160 Single Bar	0.50kg	-0500K	466.00
AD160 Case (50)	25.00kg	-0550K	19861.00

Industrial Melting Pots

A range of melting pots which have been designed for industrial melting of waxes, glues and plastics etc. for coating, casting, protecting etc. The pots are electrically heated and thermostatically temperature controlled from 50°C to 200°C.

Constructed from anodised aluminium with ceramic fibre insulation. Pots supplied with 2m cable and fused plug, lifting handle, double wall heat-conserving lid, on/off switch and safety thermal cut-out. 220/240V as standard.



Capacity		Internal Dimensions		Maximum Wattage	Order Code KEN-709	Price/1 TB
Litres	Pints	Diameter	Depth			
0.7	1.20	100mm	90mm	275	-1010K	32445.00
2.5	4.40	150mm	140mm	600	-1030K	41800.00
6.0	10.5	200mm	190mm	1125	-1060K	58857.00
12.0	21.0	250mm	240mm	1650	-1120K	68959.00

SHERLOCK
QUALITY SEALANTS
Silicone Sealants

General-Purpose Silicone

High performance acetoxy silicone provides a permanently watertight flexible seal and offers excellent adhesive properties, making it suitable for use on glass, sanitary-ware, ceramics and non-porous surfaces.

For indoor and outdoor use. Weather-proof. Mould-resistant. Life expectancy up to 25 years. Conforms to BS 5889.

Size:
310ml cartridge.



Colour	Order Code SHK-716	Price/1 TB
White	-3100K	186.00
Clear	-3110K	186.00
Black	-3130K	186.00
Grey	-3140K	186.00

Non-setting Sealant

Gas Seal

Non-setting, off-white compound for use on metallic threaded and face joints carrying gas including aluminium, copper, steel and zinc. Suitable for use with propane, butane, LPG and natural gas. Ideal for boats, camping, motor-homes, caravans, BBQs and most domestic appliances. Full bond strength is achieved immediately dependent upon humidity levels. Can be wiped up with a disposable cloth, any residual excess can be rinsed with water.

Temperature range: -20°C to +125°C.
Maximum gas pressure: 2.9psi (0.2bar)



Size	Order Code SHK-720	Price/1 TB
400g	-4010K	804.00

KENNEDY
QUALITY INDUSTRIAL TOOLING

Sealant Cartridge Applicator Guns

Economy Plastic Gun - C3

Robust, easy to use. Smooth action.
Max. cartridge size: 310ml.

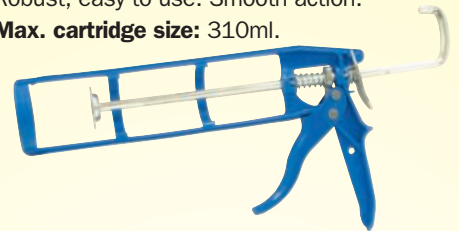

Type	Cartridge (max size)	Order Code KEN-715	Price/1 TB
C3	310ml	-1200K	372.00

Professional Metal Guns

Extremely robust and ideal for continuous use. Will not twist under pressure.



Smooth action for optimum application of sealant.

Type	Cartridge (max size)	Order Code KEN-715	Price/1 TB
C3	310ml	-1000K	466.00
C4	400ml	-2000K	629.00

P.T.F.E. Sealing Tape

Gas Type: For gas and hot water pipes (not for potable water). Made to BS EN 751:3.

Water Type: For hot and cold water pipes. Made to BS 6920 & BS 7786.

8000K



9000K



9010K



Type	Width x Length	Order Code KEN-983	Price/1 TB
Gas	12mm x 5m	-8000K	57.00
	25mm x 12m	-9010K	145.00
Water	12mm x 12m	-9000K	42.00

Ergonomic Sealant Applicator Gun

Heavy Duty Metal Gun - C3

Extremely robust and ideal for continuous use. Will not twist under pressure, ergonomically designed to reduce operator fatigue.



Smooth action for optimum application of sealant.

Type	Cartridge (max size)	Order Code KEN-715	Price/1 TB
C3	310ml	-1400K	542.00



Floor Paint

Attractive and hard wearing, transforms drab, stained or scuffed concrete and similar surfaces. Suitable for floors in warehouses, workshops, shop floors garages, basements, etc.

Coverage: up to 8m²/ltr (two coats recommended).

Please note, colours are for guidance only.



Colour	Size	Order Code	Price/1 TB
		SOL-721	
Mid Grey	5ltr	-2050E	2575.00
Tile Red		-2100K	2575.00
Mid Green		-2030C	2575.00
Dark Grey		-2040D	2575.00
Mid Blue		-2060F	2575.00
Safety Yellow		-2120K	3863.00

Anti-Slip Floor Paint

Tuffgrip

Solvent free industrial quality floor paint. Applied by roller as a one-coat system, to provide traction in areas of slip hazard. Hard wearing, epoxy resin anti-slip coating suitable for use on heavy trafficked concrete, stone, steel and wooden floor surfaces.

Coverage: 5m² per pack.

Please note, colours are for guidance only.



Colour	Order Code	Price/1 TB
	SOL-721	
Mid Grey	-3050E	8755.00
Safety Yellow	-3080H	8755.00
Tile Red	-3100K	8755.00

Hygienic Floor Paint

Suitable for floors in warehouses, workshops, shop floors, garages, basements, etc. Oil resistant and easy to clean. No primer required.

Hygienic

Water-based anti-bacterial topcoat for floors where hygiene control is essential, including hospitals, kitchens etc. Approved biocide paint with exceptional abrasion resistance. Easy to clean - resistant to oils, solvents and many chemicals.

Coverage: up to 8m² per litre (two coats recommended).

Size: 5 ltr.



NEW



Colour	Order Code	Price/1 TB
	SOL-721	
Dark Grey	-2010A	8555.00



Instant Nails

A high strength gap filling solvent-free adhesive that produces a quick 'grab' and replaces mechanical fixings in a multitude of home improvement applications. Dries white and is over-paintable when dry.



Instant Adhesive

High performance cyanoacrylate adhesive suitable for use on metal, plastic, china, leather, wood, glass and rubber. Bonds in seconds.

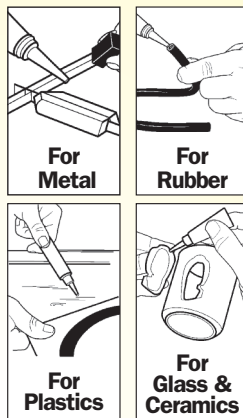

1001 uses in the Home and Workshop

Size	Order Code	Price/1 TB
	SHK-725	
3g	-6010K	42.00

Enamel Paint

This tough enamel has long lasting flexibility when used to cover rust, bare metal and wood, repelling moisture to give long term protection. It must be applied in temperatures of 5° C or above and is sag resistant to eliminate brush strokes, dilutable by white spirit and can be used for interior or exterior applications.



RAL	Colour	Size	Order Code	Price/1 TB
			SOL-721	
9005	Black	1ltr	-6110A	1029.00
		2.5ltr	-6110C	1700.00
		5ltr	-6110E	4069.00
5012	Blue	2.5ltr	-6112C	1957.00
6010	Green	1ltr	-6114A	1133.00
		2.5ltr	-6114C	1957.00
3000	Red	1ltr	-6117A	1133.00
		2.5ltr	-6117C	1957.00
		1ltr	-6118A	1236.00
9010	White	2.5ltr	-6118C	1957.00
		5ltr	-6118E	4119.00
		1ltr	-6120A	1133.00
1007	Yellow	2.5ltr	-6120C	2059.00



Size	Order Code	Price/1 TB
	SHK-725	
310ml	-6500K	102.00



Heavy Duty Spray Adhesive

Provides a flexible but ultra strong bond for many applications from foam backed carpets and carpet tiles, underfelt, flexible foams, fabrics, felt and cork to plywood, softwood, MDF, laminates, metal, hardboard, glass and rigid plastics.

Size: 500ml.



Size	Order Code	Price/1 TB
	SHK-725	
500ml	-4240K	273.00

GROUP 726/727 'O' RINGS/DEGREASERS

SHERLOCK Nitrile 'O' Ring Service Kits
QUALITY SEALANTS

Inch 'O' Rings manufactured to **BS1806**.
Metric 'O' Rings manufactured to **DIN 7715** standards.
Both kits are supplied in a durable storage box with sunken cavities for the simple location of the correct sized rings.



NEW



Size range
Inch kit: 1/8" - 2"
Metric kit: 3mm - 50mm

Product Number	Type	Number of Pieces	Order Code SHK-726	Price/1 TB
OR1	Inch	407	-5510K	773.00
OR2	Metric	419	-5520K	773.00

SOLENT MAINTENANCE

Biodegradable Degreaser

For cleaning and degreasing equipment and parts. Safe for use all around the house even on delicate surfaces. Powerful degreaser removes difficult soils such as dust-laden oils, fuels and lubricants. For virtually all hard surfaces and ferrous metals. Non-toxic, non-reactive and non-carcinogenic. Derived from renewable resources.



Size	Order Code SOL-727	Price/1 TB
1ltr	-3240D	603.00

SOLENT MAINTENANCE Just Orange

Citrus-Based Solvent Degreaser
Just Orange is a powerful, citrus-based solvent degreaser for the cleaning and degreasing of engineering components and equipment. Effectively removes heavy oils, greases, bitumen, wet paints, adhesives and sealants from virtually all hard surfaces. Contains no Chlorinated or Aromatic solvents. For use as an alternative to solvents such as acetone, benzene, butyl cellulose, CFC's, Freon, Methylene Chloride, HCFC's, isopropyl alcohol; methyl ethyl, ketone, mineral spirits, toluene, trichloroethylene, xylene etc.



Orange Plus

Citrus-Based Water Rinseable Degreaser
Orange-Plus is a highly effective, water rinseable solvent degreaser for the removal of stubborn and heavy oils, greases, paints, inks, adhesive and resins from engineering components and equipment. Once cleaned, the contaminants can be rinsed away with water. Suitable for all metals, including plant and machinery, and some plastics. Contains no Chlorinated or Aromatic solvents. For use as an alternative to solvents such as xylene, toluene, acetone etc. **Not recommended for use with Parts Washers**



Aqueous Orange

Citrus-Based Aqueous Cleaner
Aqueous Orange is highly concentrated, low alkaline blend of citrus solvents and powerful surfactants, designed to remove oils and greases, inks, polishing compounds and lapping slurry from hard surfaces. It can be diluted with water for maximum economy and its micro-emulsion formula offers the benefits of water-based efficiency with solvent based performance. It also contains a corrosion inhibitor and can be used both manually and in machine operations. Replaces white spirit, paraffin and highly alkaline cleaners.



Size	Order Code SOL-727	Price/1 TB
1ltr	-2800A	548.00
5ltr	-2810B	2075.00
20ltr	-2820C	8295.00



Size	Order Code SOL-727	Price/1 TB
5ltr	-2910B	2318.00
20ltr	-2920C	8498.00



Size	Order Code SOL-727	Price/1 TB
5ltr	-2610B	2262.00
20ltr	-2620C	8791.00



De-Icer

Fast acting de-icer that melts ice fast, perfect for those frosty mornings or evenings. The effective formula helps prevent the windows from re-freezing and works to temperatures of -20°C. Handy sized aerosol can that's quick and easy to use.



NEW

Size	Order Code	Price/1 TB
600ml	SOL-732 -9550K	N/A

Deluxe Ice Scraper

Tough one piece scraper for the effective removal of snow and ice.

Width: 95mm.
Length: 210mm.



NEW

Width	Length	Order Code	Price/1 TB
95mm	210mm	SOL-907 -4520K	N/A

Dashboard Shine

Designed for cleaning, polishing and protecting dashboards and interior and exterior trims. It restores original colour and leaves a high shine finish with a fresh strawberry fragrance. Ideal for use on plastic, vinyl and rubber. Easy to use with a spray-on and wipe application.

NEW

Size	Order Code	Price/1 TB
500ml	SOL-732 -9440K	232.00



Leather Cleaner

Enriched with Carnauba wax and Beeswax to clean, condition and protect a car's leather interior. Regular use will help maintain suppleness and prevent leather from drying and cracking. Spray-on application makes it easy to use and it is water resistant and non abrasive.

NEW

Size	Order Code	Price/1 TB
500ml	SOL-732 -9450K	232.00



Alloy Wheel Cleaner

Cleans hardened brake dust, dirt and road grime that accumulates on alloy wheels. It has a powerful, acid-free formula to remove grease and oil, whilst its thick foaming action ensures excellent adherence to vertical surfaces to reduce run-off. Easy to use with spray-on application.

NEW

Size	Order Code	Price/1 TB
500ml	SOL-732 -9430K	232.00



Brake Cleaner Spray

A fast drying, solvent based, heavy duty degreaser designed to remove dust, grease and oil from brake components and clutch assemblies. Eliminates brake squeal and clutch slip caused by contaminated components. Easy to use 360° spray application.

NEW

Size	Order Code	Price/1 TB
600ml	SOL-732 -9520K	205.00



Concentrated Screen Wash

Can be used all year round and is the ideal way to keep your windscreen clean and clear of insects, road grime and traffic film. The anti-smear formula leaves a crystal clear windscreen with every wash and resists freezing. Ideal for winter motoring. Contains water softeners.

Dilution Recommendation
Summer: 25% 1 part wash to 3 parts water.
Winter: 50% 1 part wash to 1 part water.
Harsh winter: use neat.



Size	Order Code	Price/1 TB
5ltr	SOL-732 -9400K	411.00
25ltr	SOL-732 -9420K	1236.00

Glass Cleaner

Simply spray on and wipe off to leave windows clean and sparkling. Contains vinegar for extra cleaning and a demisting additive.



Size	Order Code	Price/1 TB
750ml	SOL-780 -3025M	176.00

Tyre Shine

The durable, long lasting formula is designed to give used tyres a 'new look' deep gloss shine while helping to prevent weathering and fading. Easy to use with a spray-on application that requires no polishing or buffing.

NEW

Size	Order Code	Price/1 TB
500ml	SOL-732 -9460K	258.00





Rapid Dry Cleaner Spray

SC1-500B

Solent rapid dry solvent cleaner is supplied in a large 500ml aerosol. The product is formulated to quickly penetrate grease, oil and general soiling from metal/ electrical components and precision parts. The formulation rapidly evaporates leaving a clean, dry surface. Safe on most plastic components. Will soften some lacquers. If in doubt about suitability test on a scrap component or a small area before general application.



Size	Order Code	Price/1 TB
500ml	SOL-732-0100K	661.00

Low Odour Solvent

SC2-500B

Very fast drying. Designed for the engineering and electrical industries. As with all solvents test for compatibility before general application.

The low odour level is ideal for items where product odour would be inappropriate.



Size	Order Code	Price/1 TB
500ml	SOL-732-9640K	691.00

Trike-Free Contact Cleaner

SC2-500C

An effective solvent based cleaner. The product is formulated to remove oil, grease and carbon dust from electrical switch gear and electronic components. It is safe on most common plastic parts, but will attack lacquer finishes and coatings. If in doubt about suitability, trial the product on a scrap sample first before general application. The product is propelled from the aerosol by CO₂ carbon dioxide gas (non-flammable). Electrical Switch Cleaner fluid is flammable. Always ensure power is switched off before applying this product to electrical equipment.



Size	Order Code	Price/1 TB
500ml	SOL-732-0120K	730.00

Foaming Spray

SC5-500B

Cuts through grease, dirt, oil and general soiling, contains no silicones. Ideal for non-porous surfaces. 1000+1 uses in the home, industry, garage or factory.



Size	Order Code	Price/1 TB
500ml	SOL-732-0180K	441.00

Metal Parts Cleaner - Citrus Based

SC3-500B

Citrus based cleaners are an effective alternative to pure solvent products. Deep penetrating action rapidly removes oils, grease, and general soiling.



Size	Order Code	Price/1 TB
500ml	SOL-732-9660K	567.00

Sticky Label Remover

LR1-250B

Designed to quickly and effectively remove old and difficult to remove self adhesive labels from a wide variety of surfaces. Formulated with extra strength for the industrial user, the product will quickly penetrate the label surface and soften the adhesive layer. This product will rapidly remove labels from, metal, tile, ceramic, powder coated and glass surfaces. This product will also remove chewing gum, marker pen ink, and ball point pen ink.



Size	Order Code	Price/1 TB
250ml	SOL-732-9630K	387.00



Trike-Free Contact Cleaner

CCA500C

Suitable for cleaning and degreasing delicate components such as those used in electrical equipment. It can be used on most surfaces and will not affect PCBs, delicate plastics or painted surfaces. Non-corrosive. It contains only solvents which are permitted under the Montreal Protocol.



Size	Order Code	Price/1 TB
500ml	SSF-732-3120K	346.00

Anti-static Foam Cleaner

FCA500

This cleaner is recommended for the everyday cleaning of electronic and electrical equipment. It removes stubborn stains, nicotine, grease and general grime build-up from plastic, formica, leatherette, ceramics, glass, paintwork or any other non-porous hard surface. Ideal for use in offices, canteens, banks, schools, kitchens, washrooms and many other problem areas. It has been formulated from surfactants and solvents which are safe to use on most surfaces.



Size	Order Code	Price/1 TB
500ml	SSF-732-3180K	316.00



De-ionised Water DW25

For use in lead-acid car batteries. Also suitable for domestic appliances such as steam irons and steam cleaners, avoids problems caused by scaling. Can be used as a final rinse in car washing to avoid 'spotting'. Also suitable for rinsing scientific glassware.



Size	Order Code	Price/1 TB
25ltr	SOL-732-4250K	1088.00



Penetrating Spray

SM1-500B

Rapidly penetrates into rust and corroded fittings. Allows easy release and dismantling of fittings exposed to heat and great pressure. Can be used on wet metal components, does not contain silicone, CFCs or chlorine. Lubricates threads during release procedure, 30% less dense than water.



Size	Order Code	Price/1 TB
500ml	SOL-732-0400K	441.00

Chain & Drive Spray Lubricant

SM6-500B

Formulated to have a wide range of operating uses. Ideal lubricant for moving chains under extreme load and for chains not fitted with automatic lubrication nor running in oil baths. Formulated with a 'tacky additive' to resist 'throw off' on rapidly moving chains and drives. Ideal for fork trucks, conveyer systems, motorcycle chains. Can be used as a general-purpose lubricant for items subjected to extreme weather conditions. Can be used as a slideway lubricant for machine tools. Strong anti-rust qualities. Does not contain silicone or CFCs.



Size	Order Code	Price/1 TB
500ml	SOL-732-0500K	661.00



Wire Rope Lube Spray

WRS500

This spray lubricant has been formulated to lubricate and protect wire ropes from corrosion. It has good penetrative qualities to lubricate deep into the core of ropes, displacing water and increasing the life of the rope. 'Hi Tack' additives provide excellent adhesion to metal and reduced 'fling off' during use.



Size	Order Code	Price/1 TB
500ml	SSF-732-3450K	409.00

Penetrating Spray

POA500

Penetrating oil for dismantling, lubricating and cleaning. This oil displaces water leaving a hydrophobic coating to protect surfaces from corrosion. It penetrates threads and crevices to release and lubricate delicate mechanisms, pivot points and sliding surfaces whilst degreasing hard surfaces.



Size	Order Code	Price/1 TB
500ml	SSF-732-3400K	316.00

Chain & Drive Spray

CCA500

This product is a special blend of quality oils, greases and solvents, designed to lubricate and protect all types of cables and slow moving chains. It penetrates quickly into the centre of cables providing excellent protection to the core. It will not sling off, drip or dry out even in adverse conditions. It will also penetrate chain rollers and links enabling smoother working and reduce friction, wear and the possibility of seizure.



Size	Order Code	Price/1 TB
500ml	SSF-732-3500K	380.00



STD - Foaming Spray

For sawing, tapping and drilling. Can be used on yellow metals without the risk of staining. Foam aerosol rapidly penetrates and is able to cling to normally inaccessible areas and moving cutting edges. Extends tool life and metal removal rates. High anti-weld features. Reduces heat and improves surface finish. Fast drying and low odour. A must for all metalworkers and service engineers.



Size	Order Code	Price/1 TB
400ml	-4210K	387.00

STD - Fluid Spray

For sawing, tapping and drilling. Aerosol penetrates and is able to cling to normally inaccessible areas and moving cutting edges. Can be used on steels, stainless and ceramics. Extends tool life and metal removal rates. High anti-weld features. Reduces heat and improves surface finish. Silicone and CFC-free. A must for all metalworkers and service engineers.



Size	Order Code	Price/1 TB
400ml	-4000K	597.00

STD - Compound

For sawing, tapping and drilling. Extends tool life and metal removal rates. Reduces heat and improves surface finish. Silicone and CFC-free. A must for all metalworkers and service engineers.

STD Liquid (Poly Bottle)

Packed in a poly bottle with spout to allow controlled flood application. Extreme pressure (E.P.) lubricant. High anti-weld features. Reduces heat and improves surface finish.

STD Non-Drip Compound

For steels, stainless and ceramics. Can be used on yellow metals without the risk of staining. High anti-weld features. Reduces heat and improves surface finish. Non-drip compound can be applied by brush or by dipping the tap or drill.



Size	Order Code	Price/1 TB
500ml	-4020K	693.00
5ltr	-4060K	5665.00
500g	-4040K	568.00



Oil Spray

SM3-500C

Multi-purpose mineral lubricating oil formulated to have a wide operating range. It lubricates, penetrates, cleans and protects. Use on locks and hinges. Cleans and protects tools. Helps to release stubborn and rusted bolts. Outdoor protection making it ideal for boats. Suitable for household use yet strong enough for industrial applications. Contains a special blend of anti-rust agents which will protect all treated surfaces against corrosion. Does not contain silicone or CFCs.



Size	Order Code	Price/1 TB
500ml	-0450K	493.00

Dry Moly Spray

SD1-500B

Premium grade dry molybdenum particle lubricant. Fast drying. Ideal for fastener lubrication. Effective on all grades of steel, copper, brass, stainless steel and foundry equipment where high temperatures are common. Also for open gear lubrication and any location where a wet coating is not acceptable or would burn off. Works at up to load rates of 100,000psi. No silicone content.



Size	Order Code	Price/1 TB
500ml	-0200K	1288.00



Air Tool Oil

Excellent air release quality, low foaming ability and resists clogging. Contains anti-rust and anti-wear additives. Extremely resistant to water absorption and can be mixed with all mineral oil based lubricants without draining the system. Can be used on air tools.

ISO Grade VG22.



Size	Order Code	Price/1 TB
500ml	-8000K	389.00
5ltr	-8050K	2730.00



Cold Zinc Spray



SZ1-500B

Fast drying corrosion protection. Matches colour of newly galvanised metal. Ideal for protecting welding joints in galvanised structures. Can be used as a top coat or primer. Compatible with most paint finishes. Contains no CFCs or lead. Fitted with directional spray button designed to assist application in outdoor locations with minimum over-spray.



Manufactured and tested to:
ASTM B117
 (Hot Salt Spray)
BS AU 148:PT14 1969
 (Natural Weathering)
DIN EN ISO 12944-1
 (Corrosion Protection of Steel Structures)

Size	Order Code	Price/1 TB
500ml	SOL-732-0900K	672.00



Maintenance Liquid

AC-90

Displaces water, helps start damp engines, penetrates rust, protects from corrosion, lubricates and stops squeaks. Silicone free, electrically non-conductive and can be used on or near electrical components, motor circuits etc, without affecting insulation or causing short circuits. Available in aerosols that use no CFCs and are ozone friendly or in screw top metal cans.

Does Not Contain Kerosene*, Paraffin* or Naphtha*.

(*These products are used by some other maintenance sprays or water displacing sprays but are associated with skin drying and irritations.)



Size	Order Code	Price/1 TB
250ml Aerosol	-0050K	155.00
425ml Aerosol	-0150K	273.00
5ltr Can	-0200K	1803.00
Applicator	-0500K	258.00



M4-Plus Spray



SM4-500C 'M4 Plus'

Lubricates: High performance mineral oil based lubricant with PTFE.
Displaces Water: Helps start damp engines.
Penetrates: Releases rusty fixings.
Cleans & Protects: Cleans metal surfaces and prevents rusting of treated parts. Does not contain naphtha, kerosene or paraffin which are all associated with operator skin dryness, cracking or dermatitis. CO₂ non-flammable propellant. Does not contain silicone. Electrically non-conductive at normal ranges found in the home. Care must be taken if used on some electrical plastic components where 'crazing' may occur.



Size	Order Code	Price/1 TB
500ml	SOL-732-0460K	335.00



Cold Zinc Spray



CGA500

Fast drying corrosion protection. Matches colour of newly galvanised metal. Ideal for protecting welding joints in galvanised structures. Can be used as a top coat or primer. Compatible with most paint finishes. Contains no CFCs or lead. Fitted with directional spray button designed to assist application in outdoor locations with minimum over-spray.



Size	Order Code	Price/1 TB
500ml	SSF-732-3900K	438.00



Anti-Rust Spray

SP1-500B Green

A soft thin film moisture/ corrosion protective coating. The coating has a slight green colouring which clearly indicates treated areas. Ideal for longer term moisture/corrosion protection of machined components/moulding dies and tools. Removed easily with Solent Industrial Cleaner.



Size	Order Code	Price/1 TB
500ml	SOL-732-0600K	818.00

Heavy Duty Anti-Rust Spray



SP2-500B

High performance corrosion inhibitor, sprayed directly onto the surface to be protected. Light brown in colour to identify treated surfaces. The film has self-healing properties and is easily removed with solvent cleaners. Coating resists moisture, acid and alkali fumes. The film does not contain silicone or halogens. Corrosion protection periods vary with environmental conditions. Typical interior protection in the UK in excess of two years. Product can be re-applied should conditions require it.



Size	Order Code	Price/1 TB
500ml	SOL-732-0620K	944.00

PRODUCTS ARE ONLY AVAILABLE VIA YOUR DISTRIBUTOR



Copper Grease Spray

SM7 500B - With Graphite

Copper grease spray is particularly effective on commercial/ passenger vehicle braking systems. Extra heavy duty copper grease with graphite.

High copper content - effective up to 1100°C. No lead content/ no CFCs/ no silicone/ no chlorinated content. Directional spray button for precision application.



Size	Order Code	Price/1 TB
500ml	SOL-732-0520K	568.00

EP Open Gear Spray

SM8-500B - With Molybdenum

Solent EP Open Gear Spray lubricant is a premium extreme pressure lubricant packed in a 500ml aerosol. Based on molybdenum disulphide anti-wear additives. Suitable for lubricating all open gears where a thin film is specified. Suitable for temperatures as low as -40°C to +100°C.



Size	Order Code	Price/1 TB
500ml	SOL-732-0540K	1038.00

3-Part Flaw Detector Inspection System

Fast reliable method for visually inspecting and spot-checking surfaces of welds, exotic alloys or standard metals, highly stressed structural members, critical castings, shafts, gears, spindles, and any other hard part where identification of surface flaws is essential. Detects flaws such as cracks, pin holes, welding laps and porosity either during manufacture or on-site.

Flaw Detector Cleaner Spray

SF1-500B

Quick drying, powerful solvent for cleaning surfaces prior to testing. Removes contaminants including oils, greases and grime.



Size	Order Code	Price/1 TB
500ml	SOL-732-0240K	944.00

Flaw Detector Dye Penetrant Spray

SF2-500B

Highly sensitive red dye, for use when detecting flaws on metal components under normal lighting conditions.



Size	Order Code	Price/1 TB
500ml	SOL-732-0260K	944.00

Flaw Detector Developer Spray

SF3-500B

White film to highlight any faults which have been detected when using Flaw Detector Penetrant. The product should be removed using Flaw Detector Cleaner Spray once cracks have been found and marked.



Size	Order Code	Price/1 TB
500ml	SOL-732-0280K	944.00

Drive Belt Dressing Spray

SB1-500B

Reduces slip on drive belts and helps to stop belt squeal. Can be used on drive belts exposed to weather, ideal for farm machines, alternator drive belts and fan belts. Helps to stop cracking and extends belt life. Can be used on rubber, leather, canvas and most types of synthetic belts.



Size	Order Code	Price/1 TB
500ml	SOL-732-0060K	773.00

Brake & Clutch Component Cleaner

BC90

A fast evaporating effective cleaner for brake components. Effective formulation for suppressing dust and debris. Kind to skin.



Size	Order Code	Price/1 TB
500ml	ACN-732	308.00



Leak Detector Spray

LDA500
For checking for the most minute leaks in any gas or air pressurised systems including commercial vehicle air brakes and pressure vessels. Contains no alcohols or solvents, is not caustic and contains a rust inhibitor. Spray directly onto the suspect area using the extension tube and examine for bubbling which will indicate leakage.

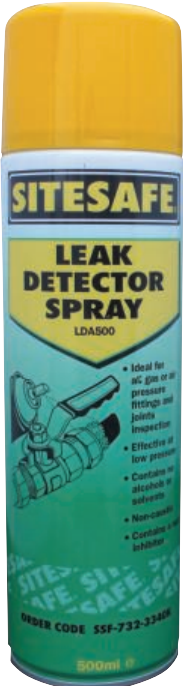

Size	Order Code	Price/1 TB
500ml	SSF-732-3340K	334.00

SL1-400A

A specially formulated, performance white fluid, designed to identify even the smallest gaseous leak. Applies a thin uniform film of surface active agents which identifies any leak or bleeding of joints. Bubbles in the film indicate the location of the leak. Will not give a false reading if mechanical sensing equipment is used. Suitable for use with most common gases.



Size	Order Code	Price/1 TB
400ml	SOL-732-0340K	498.00

SFC-415F

Fault Detector Freezer spray is a very cold rapidly evaporating high pressure gas jet. Applying to electronic components will lower the temperature of the component. Any faulty overheating component will cool and return to correct operation, thus indicating the faulty component. Cools objects very rapidly down to temperatures of -50°X. Can also be used to shrink fit metal parts where the application of heat would be inappropriate and can be used to freeze chewing gum deposits to aid removal.



Size	Order Code	Price/1 TB
415ml	SOL-732-9580K	823.00

Welder's Anti-Spatter Spray

SW1-400C
Solvent-based coating applied to metal before welding to prevent spatter from sticking to the metal. CO₂ propelled aerosol. Non-flammable. Silicone-free and removable with solvents prior to galvanising or painting.



Size	Order Code	Price/1 TB
400g	SOL-732-0840K	346.00

Water Based Anti-Spatter Fluid

SW2-400C
No solvent or silicone content. Fine spray pattern gives good coverage, prevents spatter build-up on jigs, work. Ideal where further process work is involved, eg painting, galvanising with a rust inhibitor.



Size	Order Code	Price/1 TB
500ml	SOL-732-9740K	258.00

Welder's Anti-Spatter Fluid

Reduces the risk of joint puddling and greatly reduces preparation time prior to final painting. Does not affect any subsequent galvanising or painting operations. Evaporates under normal weld temperatures. Dichloromethane and silicone-free. Non-flammable, non-toxic, non-corrosive and bio-degradable.



Size	Order Code	Price/1 TB
5ltr	SOL-732-9300K	567.00
20ltr	SOL-732-9310K	1545.00

PRODUCTS ARE ONLY AVAILABLE VIA YOUR DISTRIBUTOR



Silicone Mould Release

SR1-500B - For Plastic & Rubber
Heavy duty silicone lubricant and release agent. Formulated with a high silicone content. The product is suitable for a wide range of uses. SR1-500B is a dry, non-oily, non-greasy product. Water clear with no odour.



Size	Order Code SOL-732	Price/1 TB
500ml	-0700K	818.00

Silicone Mould Release

SR2-500B - Heavy Duty
Heavy duty silicone lubricant and release agent. Formulated with a high silicone content. Suitable for a wide range of uses. SR2-500B is a dry non-oily, non-greasy product. Water clear with no odour.



Size	Order Code SOL-732	Price/1 TB
500ml	-0720K	912.00

PTFE Mould Release

SR3-500B - Dry Film
Provides a micro-thin surface coating for the inner surfaces of injection moulding tools/dies, thus enabling easy component release. The coating will not bridge complex mould profiles and will not interfere with precision fits. The applied PTFE film will not transfer to the moulded item and can be used where a dry slip surface is required such as production line slides, tracks or tables.



Size	Order Code SOL-732	Price/1 TB
500ml	-0740K	880.00

Silicone Mould Release

SR4-500B - For Polyurethane
Specifically for use with integral skin and elastomeric polyurethanes. Provides high gloss finish, low build-up on the mould surface generated to 200°C. Silicone based product may not be suitable for use where painting, plating work is required.



Size	Order Code SOL-732	Price/1 TB
500ml	-9700K	464.00

Silicone Mould Release

SR6-500B - Thermoplastic
Silicone based. Formulated to provide effective release of plastics with lower melt temperatures. Effective with natural rubbers. Effective to 200°C, excellent surface finish.



Size	Order Code SOL-732	Price/1 TB
500ml	-9720K	720.00

Silicone Free Mould Release

SN1-500B - For Plastic & Rubber
Specifically formulated for rapid release of moulded components. Particularly suitable for moulded items which require further process, eg painting, printing and thermo welding.



Size	Order Code SOL-732	Price/1 TB
500ml	-9680K	670.00

KENNEDY *Line Markers*
QUALITY INDUSTRIAL TOOLING

For use on car parks, factory/ warehouse floors, playgrounds, sports fields, tennis courts, leisure centres and road surfaces.
For stencils, line or free hand marking. CFC free formula, contains no lead additives. Fully compatible with major brand applicators.

750ml Can

Size: 750ml can.



Please note, colours are for guidance only.

Colour	Application	Order Code KEN-734	Price/1 TB
White	General Marking	-6020K	325.00
Yellow	Hazard/Caution	-6040K	325.00
Blue	Mandatory	-6060K	325.00
Red	Prohibition/Danger	-6080K	325.00
Green	Safe Condition/Direction	-6100K	325.00
Orange	Hazard/Caution	-6120K	325.00
Black	Deletes Existing Lines	-6140K	325.00
Grey	Deletes Existing Lines	-6160K	325.00

Line Marking Gun

Manufactured from reinforced nylon. For offering trigger action to line marking spray cans, giving improved comfort during prolonged use.



Description	Order Code KEN-715	Price/1 TB
Line Marking Gun	-6200K	1029.00

Permanent Markers

Designed for use on all surfaces. Waterproof, low solvent content. Xylene-free.



Colour	Pack Quantity	Order Code KEN-734	Price/Pk TB
Black	10	-5020K	691.00
Blue	10	-5060K	691.00
Red	10	-5040K	691.00
Green	10	-5070K	691.00

PACK OF 10

Industrial Paint Markers

Designed for countless metal marking applications. Can be used for marking greasy, rusty, or new metal surfaces. Also suitable for marking glass, plastic, wood, ceramics etc. Ballpoint nozzle cap will only allow ink flow when applied and pressed to the workpiece - ink cannot be spilt from the cap unintentionally. One head can be interchanged from differing inks and bottles. Can be refilled from one litre bulk refills of the specially formulated ink.



Please note, colours are for guidance only.

Colour	Size	Order Code KEN-734	Price/1 TB
Yellow	46ml	-3020K	308.00
White	46ml	-3040K	308.00
Blue	46ml	-3060K	308.00
Green	46ml	-3080K	308.00
Black	46ml	-3100K	308.00
Red	46ml	-3120K	308.00
Orange	46ml	-3140K	308.00

Ink Refill Cases

Colour	Size	Weight each	Order Code KEN-734	Price/1 TB
Yellow	1ltr	1.4kg	-3210K	2121.00
White	1ltr	1.4kg	-3230K	2121.00

Ballpoint Head

Replacement ballpoint head for Kennedy Industrial paint 46ml marker bottles.



Material	Ball Size	Order Code KEN-734	Price/1 TB
Nickel	2.4mm	-3500K	122.00

SOLENT MAINTENANCE

Bullet Tipped Industrial Paint Markers

For use on steel, aluminium, rubber, timber, plastic, ceramics and other materials. Bullet tipped. 2.3mm point size.



Colour	Order Code SOL-734	Price/1 TB
Black	-0010K	205.00
Green	-0030K	205.00
White	-0050K	205.00
Yellow	-0060K	205.00

STUARTS Micrometer Paste

Oil-based paste for indicating high spots on machine bearings, machine tool beds etc. Easily removable with methylated spirit.



Colour	Pack Size	Order Code MIR-734	Price/1 TB
Blue	32g Tube	-8810B	402.00
	38g Tin	-8800A	341.00

PRODUCTS ARE ONLY AVAILABLE VIA YOUR DISTRIBUTOR



Food Safe White Grease

Intended use for lubrication of bearings, slides and all delicate mechanisms used in the food manufacturing/processing industry. Maximum operating temperature 150°C with excellent load carrying capacity and water resistance. Non-toxic. **FDA Compliant. NSF H1 registered.**



Size	Order Code	Price/1 TB
500ml	SOL-740 -6850E	735.00

Food Safe High Tech Grease

Fully synthetic translucent non-melting grease that allows fluid to penetrate into machine parts before setting to a No. 2 rated grease. Protects and lubricates with a non-toxic anti-corrosive shield. Non-toxic lubricant ingredients listed by the **FDA** and is **INS H1 registered**. Totally salt or fresh water-resistant to be used inside and out on machinery in temperatures ranging from 40°C to +340°C.



Size	Order Code	Price/1 TB
500ml	SOL-740 -6220C	965.00

Food Safe Anti-Seize Paste

Formulated for use on assemblies in difficult areas where fretting corrosion and corrosion induced by wet environments occur. It can also be used to lubricate slow moving slides and pivot pins. Resistant to hot, cold and salt water it can be used across a wide temperature range where the solid lubricate including PTFE gives excellent dry lubrication and forms a barrier between all surfaces. Non-toxic, it complies with **FDA** regulations and is **H1 registered**.



Size	Order Code	Price/1 TB
500g	SOL-740 -6720B	1130.00

Food Safe Degreaser

This **H1 registered** all-purpose cleaner/ degreaser is designed for food production areas where incidental contact may occur. It is non-abrasive, non-chlorinated, water clear, low odour, fast evaporating, it leaves no residue or deposits behind. It can be safely used on machinery, worktops and floors.



Size	Order Code	Price/1 TB
500ml	SOL-740 -6810L	531.00

Synthetic Grease

Constructed using pure non-toxic synthetic base oils, combined with PTFE and a complex mix of anti-oxidant and EP packages. Completely resistant to salt water and high humidity environments. Dielectric and can be used to protect electrical equipment from ingress of water. Lubricates bearings, chains and sliding surfaces including plastic bearings and runners. Has a wide temperature operating range -40°C to 340°C. Grease clean food safe lubricant. Non-melting.



Size	Order Code	Price/1 TB
100ml	SOL-740 -6200A	285.00
400ml	-6210B	823.00

Food Safe Silicone Grease

A versatile silicone grease for operation in extremes of high and low temperature. Can also be used on food product applications or where water repellent properties are of prime importance as it offers excellent physical performance and is **INS H1 registered**. Non-melting, water repellent, odourless, non-toxic, low volatility. High dielectric. resistant to oxidation. Thermally stable ozone resistant. Minimal effects on rubbers, plastics and metals. Unaltered by UV light.



Size	Order Code	Price/1 TB
100ml	SOL-740 -6250D	611.00
400ml	-6260E	1209.00
500g	-6270F	1294.00

Food Safe White Grease

Intended use for lubrication of bearings, slides and all delicate mechanisms used in the food manufacturing/ processing industry. Maximum operating temperature 150°C with excellent load carrying capacity and water resistance. **FDA Compliant. INS H1 registered.** Non-toxic.



Size	Order Code	Price/1 TB
400ml	SOL-740 -5900A	443.00
5.0kg	-5905C	4119.00
12.5kg	-5910E	10299.00

Group 540



Food Safe Lubricating Oil

This lubricant is completely clear, odourless and food safe. It contains no mineral hydrocarbons and is **FDA** compliant and **INS H1 registered**. It is a hydrophobic oil and therefore does not take in water, providing a barrier between water condensation and metal surfaces. This versatile lubricant can be used on sliding and rolling element bearing surfaces, metal, wood and plastics. Non-flammable. Non-toxic. Anti-corrosive. Safe for use at temperatures from -60° to +260°C.



Size	Order Code	Price/1 TB
500ml	SOL-740 -5960G	675.00

Food Safe Penetrating Oil

For dismantling, lubricating and cleaning. This odourless oil is tasteless and displaces water leaving a hydrophobic coating to protect surfaces from corrosion. It penetrates threads and crevices to release and lubricate delicate mechanisms, pivot points and sliding surfaces whilst degreasing hard surfaces. Can be used as a light lubricant. **FDA Compliant. INS H1 registered.** Food safe. Synthetic translucent. Tasteless water white fluid. Non-toxic. Anti-corrosive.



Size	Order Code	Price/1 TB
500ml	SOL-740 -5930D	603.00

Food Safe Belt Dressing

This **H1 registered** product is designed to extend life of leather, rubber and synthetic belts. Cleanly applied from the 500ml aerosol, it improves grip and allows the belt to transmit full power without slipping even in wet and damp environments.



Size	Order Code	Price/1 TB
500ml	SOL-740 -6760F	565.00

LUBRICANTS & CHEMICAL PRODUCTS



Food Grade Multi-Purpose Lubricant

AC90-FG H1

Food grade multi-purpose maintenance liquid lubricant is industrial strength. Holds **H1** approval from **NSF # 143549** and **InS # 1795389** and therefore can be used safely in all food processing locations. The only maintenance spray certified by both the **NSF** and **InS**. Does not contain silicone or CFCs. Tasteless and odourless.



Size	Order Code	Price/1 TB
425ml	ACN-732 -0260K	411.00

Food Grade Silicone Release Agent

SP90-FG H1

Superior silicone dry lubricant formulated to provide extra performance and maximum silicone release. Temperature range -65°C to +315°C. Holds **H1** approval from **NSF # 143541** and **InS # 1795388**. Odourless, tasteless, chemically inert.



Size	Order Code	Price/1 TB
500ml	ACN-732 -9010K	664.00

Food Grade Chain & Drive Lubricant

CD90-FG H1

Holds **H1** approval from **NSF # 143540** and **InS # 1795390**. Clear viscous oil with a flashpoint 240°C. Viscosity 20°C at 238mm²/s. Density at 15°C .865kgm³. Boiling point 370°C. No taste or smell.



Size	Order Code	Price/1 TB
500ml	ACN-732 -2260K	720.00

PRODUCTS ARE ONLY AVAILABLE VIA YOUR DISTRIBUTOR

GROUP 740 METAL WORKING LUBRICANTS

SOLENT+ LUBRICANTS+ Soluble Cutting Oil - Aluminium

So-Cool 'Plus' Aluminium

Semi-synthetic, environmentally improved – does not contain sodium nitrite, phenols, triazene, PTBBA or chlorinated additives. Enhanced sump life and excellent anti-foam characteristics. Optimum tool life on the most arduous jobs. Excellent corrosion protection and lubrication to cutting areas, machine fixtures, slides etc. Low emulsion odour. Low drag out losses. Easily removed in splash areas. Resists the formation of aluminium soaps - Improves filtration and machine cleanliness.

Recommended concentrations:

General machining 7% or (a dilution of 14 to 1). Heavy duty machining 10% or (a dilution of 10 to 1).

Supplied in 20ltr stacking poly container.



Grade	Size	Order Code SOL-740	Price/1 TB
SC-ALU	20ltr	-4533B	9269.00

Soluble Cutting Oil Multi-Purpose

So-Cool 'Plus' GP

Environmentally improved - does NOT contain phenols, boron, triazene, PTBBA or chlorinated additives. Based on highly refined mineral oils. High degree of machine tool lubrication. Ideal for a wide range of machining operations. Low odour. Low unit cost. Specially formulated for use in both hard and soft waters.

Recommended concentrations:

General machining 7% (dilution of 14 to 1). Grinding (surface, cylindrical centreless) 2 - 3% (dilution of 50 to 1 or 33 to 1).

Supplied in 20ltr stacking poly container.



Grade	Size	Order Code SOL-740	Price/1 TB
SC-GP	20ltr	-4508B	6695.00

Soluble Cutting Oil - Stainless

So-Cool 'Plus' Stainless Steel

Environmentally improved - does NOT contain phenols, boron, triazene, PTBBA or chlorinated additives. Based on highly refined mineral oils. High degree of machine tool lubrication. Ideal for a wide range of machining operations. Low odour. Low unit cost. Stable emulsions in very soft and very hard water.

Recommended concentrations:

General machining 7% (dilution of 14 to 1). Heavy machining 10% (dilution of 10 to 1).

Supplied in 20ltr stacking poly container.



Grade	Size	Order Code SOL-740	Price/1 TB
SC-INOX	20ltr	-4600B	8755.00

Soluble Cutting Oil - Aerospace

So-Cool 'Plus' Aerospace

Specifically designed for use in the aerospace industry on all high performance alloys, Stainless steel, titanium and aluminium alloys - in particular series 7000 aluminium.

Advantages/Benefits:

Nitrite and chlorine-free. Secondary and tertiary amine-free formulation. Reduced risk of staining and corrosion. Long sump life. Emulsifiable residues to promote clean working environment. Does not contain PTBBA.

Approvals:

AIRBUS ABR 9-0204. The military division of British Aerospace. Turkish Aerospace Industries (TAI).

Supplied in 20ltr stacking poly container.



Grade	Size	Order Code SOL-740	Price/1 TB
SC-AERO	20ltr	-4570B	9785.00

Soluble Grinding Oil - Synthetic

So-Cool 'Plus' Syn Grinding

Fully synthetic formulation. Long working life therefore economical. Minimises wheel glazing. Effective corrosion resistance. Stable emulsions in soft and hard water. Does not contain PTBBA.

Recommended concentration for general machining operations:

Grinding Cast Iron 2 % to 3.5% (dilution of 50 to 1 or 30 - 1).

Steel and Ni/Cr steel 2% (dilution of 50 - 1).

Supplied in 20ltr stacking poly container.



Grade	Size	Order Code SOL-740	Price/1 TB
SC-GS	20ltr	-4620B	9013.00

Lithium Grease

So-Grease EP2

High load lead-free lithium grease. Contains anti-rust additives to protect against corrosion. Anti-oxidants included to prolong product life. High ageing stability/high oxidation stability.

Supplied in 400g, 5kg, 12.5kg or 50kg containers.



Pack Type	Size	Order Code SOL-740	Price/1 TB
Cartridge	400g	-5100K	222.00
Tub	5.00kg	-5105C	2215.00
Pail	12.5kg	-5110M	5665.00

SOLENT LUBRICANTS Heavy Duty System Cleaner

Grade SC-SYSTEM

For use in cleaning water-based operating fluids and coolants from central systems or individual machines. Free of secondary alkanolamines, heavy metal compounds, phenols, hexahydrotriazine and nitrite. Excellent cleaning action. Storage temperature of 5 to +40°C.

NOTE: So-Clean System at 1- 2% is added to the used operating fluid about eight to twelve hours before draining. The complete cleaning effect is only achieved if the operating fluid circulates through all working parts of the system. Neither pH value nor foaming of the operating fluid change significantly when So-Clean System is added. Soil in machines, tubes and reservoirs of the system are loosened and re-emulsified.

For heavily soiled systems, increasing the dwell time to 24 hours is recommended. Thick sediment deposits are best removed mechanically and rinsed off with clean water. Supplied in 20ltr stacking poly container.



Size	Order Code	Price/1 TB
20ltr	SOL-740 -4800B	9116.00

Sump Emptier

With stainless steel Venturi pump. Screws into 205ltr oil drums. Uses compressed air to create a powerful vacuum. Empties liquid and suspended solids from tanks and can fill a drum in as little as 90 seconds, making it ready for appropriate disposal. Shuts off automatically when done.



Product Number	Order Code	Price/1 TB
PM175K	SOL-740 -8940G	40170.00

LUBRICANTS & CHEMICAL PRODUCTS

Tramp Oil Belt Skimmers

Designed to effectively and simply remove tramp oil floating on the surface of cutting fluid. Prevents the 'Monday morning smell', extends coolant life and reduces the risk of dermatitis. Compact units fit to the side or above the tank. 240V. Supplied with plug. Product FT400 can be run continuously.

Overall length: 440mm

(from top of bracket to bottom of belt).

Maximum insertion depth: 150mm.

Case dimension (L x W x D):

80 x 80 x 502mm.

Belt width: FT300 = 30mm; FT400 = 40mm.



FT400



FT300

Product Number	Removal Rate	Order Code	Price/1 TB
FT300	3ltrs per hr	-8860B	16995.00
FT400	4ltrs per hr	-8880D	40170.00

OXFORD PRECISION Portable Optical Refractometer

For determining the concentration of oil in water emulsions and transparent solutions, such as machine shop coolant. Maintaining the correct mixture in coolant systems is vital to ensure optimum performance from cutting tools. To protect the machine and workpiece from corrosion and to reduce the risk of health hazards arising from incorrect concentrations of water soluble oils. To economise the use of water base cutting fluids and grinding fluids.

Range ND: 1.333 - 1.356. Bx: 0 - 15%.

Eyepiece magnification: 11x.

Telescopic lens magnification: 4x.

Accuracy: ±0.0003 ±0.2%

Latic value: 0.0005 0.2%

Supplied in a plastic case complete with calibration screwdriver and operator manual.



Lens for Portable Refractometer

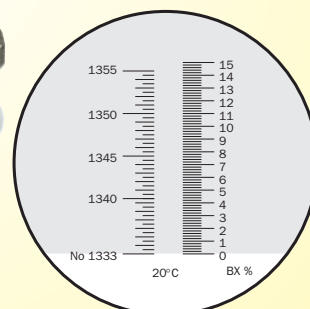

Calibrated Refractive Scale

Dimensions	Weight each	Order Code	Price/1 TB
38 x 38 x 185mm	30g	OXD-336 -1010K	6695.00

Spares			
Description	Weight each	Order Code	Price/1 TB
Lens for Portable Refractometer	10g	-3630K	582.00

PRODUCTS ARE ONLY AVAILABLE VIA YOUR DISTRIBUTOR



GROUP 780 **HAND & SKIN CARE**



Page **664 - 666**

GROUP 780 **AIR FRESHENERS**



Page **667**

GROUP 780 **HYGIENE PRODUCTS**



Page **667 - 668**

GROUP 907 **BRUSHWARE & CLEANING PRODUCTS**



Page **669 - 673**

GROUP 907 **BINS**



Page **674**

GROUP 918 **REFUSE SACKS & PLASTIC BAGS**



Page **674**

GROUP 930 **HAND WIPES & CLOTHS**



Page **675**

GROUP 952 **TOILET TISSUE**



Page **676**

GROUP 952 **HAND TOWELS/ROLLS**



Page **677**

GROUP 952 **WIPER CLOTHS**



Page **677**

GROUP 952 **WIPER ROLLS**



Page **677**

GROUP 952 **TISSUE & WIPER DISPENSERS**



Page **677**



JANITORIAL & HYGIENE

**Product Groups
780 - 952**

Product Grading



Production

High performance industrial tooling designed for continuous use applications on machine tools where repeatability and long tool life are of critical importance.



Professional

Industrial tooling that has enhanced features and benefits demanded by craftsmen and professional users.



Industrial

Designed for regular use in industrial applications. Manufactured to stringent quality levels and international standards.



Workshop

Standard quality tooling for use by tradesmen and generally industrial use.



Maintenance

Products designed for general maintenance of machines, workshops, garages and some household applications.



Home Improver

DIY quality tooling. Designed for home use and light industrial applications.

Contents

Description	Group	Page
Bins	907	674
Brushware & Cleaning Products	907	669 - 673
Hand & Skin Care - Food Industry	780	666
- Wipes	780	675
Hand Towels	952	677
Hand Towel Rolls	952	677
Hand Wipes & Cloths	930	675
Hygiene - Air Fresheners	780	667
- Bleaches & Disinfectants	780	667
- Floor Cleaners & Polishes	780	667
- Surface Cleaners	780	667
- Washing Up & Laundry	780	668
- Washroom & Toilet Cleaners	780	668
Refuse Sacks & Plastic Bags	918	674
Tissue & Wiper Dispensers	952	676 - 677
Toilet Tissue	952	676
Wiper Cloths	952	677
Rolls	952	677

SOLENT™ Professional Hand and Skin Care System
CLEANING & HYGIENE



The Solent™ Cleaning and Hygiene pouch hand cleanser/soap system uses 2ltr sealed pouch cartridges to minimise spillages and waste, this system helps to prevent cross contamination.

A full range of barrier creams, sanitisers, soaps, beaded hand cleansers and afterwork reconditioning creams are available for use with the dispensers.

Dispenser Pumps

All creams, soaps and gels: Use with 2mm pump.
All beaded hand cleansers: Use with 3mm pump.



CUT OUT CROSS CONTAMINATION!

Pump Size	Capacity	Use With	Order Code SOL-780	Price/1 TB
2mm	2ltr	Creams Soap & Gels	-1160J	2027.00
3mm	2ltr	Beaded Cleaners	-1150H	2223.00

PROTECT

Universal Barrier Cream

A pre-work cream that protects your hands. Use with 2mm pump dispenser. Supplied individually, boxed in 6's.



Description	Pouch Size	Order Code SOL-780	Price/1 TB
Universal Barrier Cream	2ltr	-1950Q	526.00

CLEANSE

Beaded Hand Cleaners

Citrus-based beaded hand cleaners. Use with 3mm pump dispenser. Supplied individually, boxed in 6's.



Description	Pouch Size	Order Code SOL-780	Price/1 TB
Lemon Hand Cleaner	2ltr	-0901F	526.00
Lime Hand Cleaner	2ltr	-1001F	541.00
GT Hand Cleaner	2ltr	-2550E	526.00

SANITISE

Anti-Bacterial Cleansers

Anti-Bacterial Soap

Formulated from a blend of natural soap, conditioner and mild surfactants. Ideal for frequent use. Supplied individually, boxed in 6's.



Cool Gel Hand Sanitiser

An alcohol-based hand sanitiser kills any bacteria (effective against MRSA) yeast or moulds. Use with 2mm pump dispenser. Supplied individually, boxed in 6's.

Description	Pouch Size	Order Code SOL-780	Price/1 TB
Anti-Bacterial Soap	2ltr	-2560F	526.00
Cool Gel Sanitiser	2ltr	-2660J	642.00

Luxury Soaps

Luxury Peach Soap

Luxury peach soap produces a rich creamy lather for effective hand cleaning. Lightly scented with a fresh peach fragrance. Use with 2mm pump dispenser. Supplied individually, boxed in 6's.

Gel Soap

Pure golden, unperfumed gel soap suitable for all general hand cleaning uses. Use with 2mm pump dispenser. Supplied individually, boxed in 6's.



Description	Pouch Size	Order Code SOL-780	Price/1 TB
Peach Luxury Soap	2ltr	-2630A	456.00
Gel Soap	2ltr	-2680L	438.00

RESTORE

Afterwork Reconditioning Hand Cream

Replaces natural oils removed during a day's work. Use with 2mm pump dispenser. Supplied individually, boxed in 6's.



Description	Pouch Size	Order Code SOL-780	Price/1 TB
Afterwork Cream	2ltr	-1980T	526.00



SOLENT **CLEANING & HYGIENE** **Beaded Hand Gel Cleanser - Lime**

Heavy-duty citrus-based degreasing and cleansing agent. Hard on grime yet kind to your skin. Unique lemon and lime formula combines nature's strength and fragrance. Ideally suited for industrial, household, workshop, outdoor, cleaning of hands. Now available in four sizes with suitable dispensing equipment.

Tub System



5ltr Poly Bottle



ENVIRONMENTALLY FRIENDLY FORMULATION

Bulkfill Systems

ENVIRONMENTALLY FRIENDLY FORMULATION



Description	Order Code SOL-780	Price/1 TB
3ltr Tub	-1003H	665.00
Pump Dispenser	-1130F	711.00
Cage	-2300W	205.00
Tub Kit	-1140G	1142.00

CAN BE USED WITH PUMP DISPENSER OR BULK FILL DISPENSER (Right)

Description	Order Code SOL-780	Price/1 TB
5ltr Poly Bottle	-1005L	645.00
Pump Dispenser	-1125D	304.00

Description	Order Code SOL-780	Price/1 TB
15ltr Pail	-1015M	1983.00
Bulkfill Dispenser	-2240M	2653.00

Orange D440 Beaded Hand Cleaner

Non-toxic, citrus-based beaded hand cleaner, cuts through the heaviest of industrial grease and grime quickly and easily. Environmentally friendly, and contains no harsh chemicals. Removes oil, tar, grease, paint, ink, glue etc. Antiseptic and bactericidal. Water rinsable, leaves no oily residue.



Size	Order Code SOL-780	Price/1 TB
2.5ltr	-1202G	1113.00

Swarf Beater Hand Gel

Lime green coloured unperfumed gel soap. Easy to apply and quickly rinses off with water leaving no residue on the skin. Suitable for removing oil, grease, and general soiling. Handy 240g tub size for easy carrying and storage.



Size	Order Code SOL-780	Price/1 TB
240g	-2540D	147.00

Liquid Hand Soap - Professional

Luxury peach soap leaves hands feeling clean, smooth and conditioned.



Type	Order Code SOL-780	Price/1 TB
1ltr	-2600X	211.00
5ltr	-2610Y	438.00

Natural Beaded Hand Cleaner

Natural beaded hand cleaner uses two types of scrubbing additives, wood flour to absorb grease/grime and poly beads to remove more stubborn soiling like tar, inks and paints. These combine to produce a dense cleansing lather to deliver a powerful solvent-free natural cleaning action that is gentle on your skin.



Type	Size	Order Code SOL-780	Price/1 TB
Poly Bottle	5ltr	-1305L	696.00
Pail	15ltr	-1315M	2043.00
Bulkfill Dispenser	2ltr	-2240M	2653.00

Lemon™ Beaded Hand Cleaner

Citrus-based degreaser, environmentally friendly, and contains no harsh chemicals. Removes oil, tar, grease, paint, ink, glue etc. A deodorising lemon scent that eliminates oil and swarf odours, leaving the skin feeling fresh after use. Water rinsable - leaves no oily residue.



Type	Size	Order Code SOL-780	Price/1 TB
Poly Bottle	5ltr	-0855L	670.00
Pail	15ltr	-0865M	1957.00
Bulkfill Dispenser	2ltr	-2240M	2653.00

Professional Hand Soap

Supplied in packs of 12x 70g bars. Lightly scented. For domestic use, in hotels, schools, restaurants and commercial premises. Rich creamy lather in all water types.



Type	Pack Qty	Order Code SOL-780	Price/Pk TB
Buttermilk	12	-2530D	208.00

JANITORIAL & HYGIENE

PRODUCTS ARE ONLY AVAILABLE VIA YOUR DISTRIBUTOR

GROUP 780 HAND & SKIN CARE

SOLENT CLEANING & HYGIENE Dry Work Barrier Cream

Pre-work cream protects skin against dry substances, dry powders, oils or solvent-based liquids.



Size	Order Code	Price/1 TB
2.5kg	SOL-780 -2020B	596.00

Wet Work Barrier Cream

Pre-work cream protects skin against water-based liquid solutions, cutting oils, detergents, acids, coolants and foodstuffs.



Size	Order Code	Price/1 TB
1ltr	SOL-780 -2050D	759.00
2.5kg	-2060E	992.00

Reconditioning Cream - Professional

Replaces moisture loss after contact with contaminants, contains natural oils to keep skin moist.

Size: 1ltr.



Description	Order Code	Price/1 TB
Reconditioning Cream	SOL-780 -2100G	292.00

Standard Duty Workshop Hand Wipes

Soft white wipes. Removes oil, grease, ink and general dirt. Waterless - no need to rinse hands after cleaning. Ideal for mobile repair and maintenance vans and use around the workshop.



PACK OF 150

Pack Qty	Order Code	Price/Pk TB
150	SOL-930 -3900K	882.00

Heavy Duty Hand Wipes

Impregnated with mild abrasive fibres to remove oil, grease, general grime plus difficult to remove contaminants such as paints, sealants, most inks and ground-in dirt. A genuine waterless hand cleaning wipe with no need to rinse after use, ideal for mobile repair and maintenance vans as well as use around the workshop. Supplied in handy pack of 50 wipes or tubs of 100 wipes.



EXTENDED RANGE

Pack Qty	Order Code	Price/Pk TB
50	SOL-930 -3800K	411.00
100	-4000K	964.00

SOLENT HYGIENE FOR FOOD Food Safe Wipes

Hand Wipes
These non-toxic single-use wipes are excellent for killing lethal bacteria and prevent cross-contamination.

Size: 20 x 30cm.



PACK OF 200

Pack Qty	Order Code	Price/Pk TB
200	SOL-930 -4400K	759.00

Cool Gel Handy Packs

Alcohol-based. Kills any bacteria (effective against MRSA) yeast or moulds. Fast drying removing the need for rinsing or drying with towels. Now available in two handy pack sizes for use on the move or at work. Independently tested. Passes **EN1276** and **EN13727** non-flammable/non-toxic.



Size	Order Code	Price/1 TB
80ml	SOL-780 -2650E	133.00
500ml	-2652G	266.00

Hand Cleanser

Anti-Bacterial Hand Soap

Formulated from a blend of natural soap, conditioner and mild surfactants. Independently tested. Passes **EN1276**, **EN13727** and **EN13704** non-toxic / active against MRSA, Clostridium Difficile, E-Coli, Salmonella and Listeria (Amongst other bacteria) Pseudomonas Aeruginosa.



Description	Size	Order Code	Price/1 TB
Anti-bacterial Hand Soap	500ml	SOL-780 -2558D	186.00

Luxury Peach Soap

Produces a rich creamy lather for effective hand cleaning. Lightly scented with a fresh peach fragrance.



Description	Size	Order Code	Price/1 TB
Luxury Peach Soap	500ml	SOL-780 -2598V	160.00



Laundry Powder

Fresh fragrance for whites and coloured fabrics. For automatic and top loading machines.



Product	Qty	Order Code	Price/1 TB
Biological	10kg	SOL-780 -4010A	1699.00

Air Fresheners

300ml aerosol room fresheners replace offensive odours with a pleasant scent.



Description	Order Code	Price/1 TB
Pot Pourri	KEN-722 -1500K	92.00
Wild Berries	-1510K	92.00
Scented Jasmine	-1520K	92.00

Contract Bleach

A solution containing 4% sodium hypochlorite, for use in toilets, sinks and drains.



Type	Size	Order Code	Price/1 TB
Poly Bottle	5ltr	SOL-780 -3001M	222.00

Professional Floor Cleaner Gel

Pine oil-based gel for maintaining hard floor surfaces, including wood block, lino, vinyl and terrazzo. Can be buffed to a high gloss, non-slip sheen.



Type	Size	Order Code	Price/1 TB
Poly Bottle	5ltr	SOL-780 -3010X	526.00

All-Purpose Cleaner Professional

A thick lemon scented gel for use on all hard surfaces, walls, vinyl seats and coverings.



Strength	Size	Order Code	Price/1 TB
Professional	5ltr	SOL-780 -3011Y	585.00

Concentrated Thick Bleach

Powerful thick formula effective against all pathogenic organisms. Contains added detergents for improved cleaning.



Type	Size	Order Code	Price/1 TB
Poly Bottle	5ltr	SOL-780 -3007T	409.00

Concentrated Hard Surface Cleaner/Degreaser

Can be diluted with up to 50 parts of hot or cold water. Rapidly breaks down grease and fat. Apply by hand scrubbing, mopping, power wash systems or mechanical floor scrubbing machines. Can be used on concrete floors, walls, paintwork, components etc.



Type	Size	Order Code	Price/1 TB
Poly Bottle	5ltr	SOL-780 -6300A	333.00
Plastic Drum	20ltr	-6310B	1478.00

Graffiti Remover

An aggressive graffiti remover suitable for cleaning the following surfaces: polyethylene, polypropylene, nylon, UPVC, bare metal surfaces, powder-coated surfaces, varnished wood, reflective signs and acrylics. May be used on some gloss paints (small test area first advised).

Size: 500ml.



Size	Order Code	Price/1 TB
500ml	SOL-732 -0300K	464.00

Contract Pine Disinfectant

For general cleaning with a pleasant pine fragrance.



Type	Size	Order Code	Price/1 TB
Poly Bottle	5ltr	SOL-780 -3003P	170.00

Cleaning & Hygiene Wash & Wax

High foam, high gloss vehicle shampoo. Mild formula, neutral pH, water-based. Lifts traffic film without harm to polished paintwork and trim. With foam boosters for fast removal of dirt and grease. High gloss wax finish. Can be used with hot or cold pressure washing systems or hand washing. Easy to handle container.



IDEAL FOR CARAVANS AND MOBILE HOMES

Type	Size	Order Code	Price/1 TB
Poly Bottle	5ltr	SOL-780 -6500A	696.00
Plastic Drum	20ltr	-6510B	2451.00

Traffic Film Remover Concentrate

Removes dirt, grime, grease and tenacious traffic film from all vehicles. Suitable for cleaning chassis and bodywork on vehicles. Designed for high pressure washing with mechanical power wash systems. Concentrated formula can also be used to clean machinery, floors, walls, asphalt; will also remove co-polymer waxes used in new car production.



Type	Size	Order Code	Price/1 TB
Poly Bottle	5ltr	SOL-780 -6400A	642.00
Plastic Drum	20ltr	-6410B	2451.00

JANITORIAL & HYGIENE

SOLENT™ CLEANING & HYGIENE
Washing-Up Detergent

Contract

A fully biodegradable 15% high active detergent for use as dishwashing liquid and general cleaning.



Size	Order Code	Price/1 TB
5ltr	SOL-780 -3005R	361.00

Washing-Up Detergent

Professional

A highly concentrated (up to 30%) liquid for hand dishwashing and general cleaning.



Size	Order Code	Price/1 TB
5ltr	SOL-780 -3008V	346.00

Oven Cleaner

Removes baked-on food residues from ovens and grills. Do not use on aluminium or galvanised metal.

Approx cleaning times:

Light grease:

3 mins (cold oven),
1 min (hot oven).

Heavy grease:

30 mins (cold),
5 mins (hot).

Baked-on grease:

12hrs (cold),
2hrs (hot).



Size	Order Code	Price/1 TB
750ml	SOL-780 -3023K	201.00

Window Cleaner

Simply spray on and wipe off to leave windows clean and sparkling. Contains vinegar for extra cleaning and a demisting additive.



Size	Order Code	Price/1 TB
750ml	SOL-780 -3025M	176.00

Stainless Steel Cleaner

Silicone-free cleaner polish. For rapid cleaning and polishing of all stainless steel, chrome, aluminium, laminates and enamel. Ideal for serveries, kitchen appliances, food displays.



Size	Order Code	Price/1 TB
750ml	SOL-780 -3026N	232.00

Lemon Quest Washing-Up Liquid

Concentrated to last. For use as dishwashing liquid and general household cleaning.



Group 907

Type	Size	Order Code	Price/1 TB
Lemon	1ltr	SOL-780 -2910T	112.00

Medium Strength Toilet Cleaner

For cleaning and descaling ceramic sanitary fittings including urinals, WCs and wash basins. Suitable for industrial household, recreational, leisure and toilet/ washroom facilities.



Product	Size	Order Code	Price/1 TB
Toilet Cleaner	1ltr	SOL-780 -2912W	123.00
	5ltr	-3004Q	438.00

Chanel-Blox

Deodorant cubes for use in urinal bowls and channels. Supplied in plastic tub.



PACK OF 150

Product	Size	Order Code	Price/1 TB
Chanel-Blox	3kg	SOL-780 -2710D	1459.00



Nail Brushes

90mm long, with stiff bristles on both sides. For cleaning both hands and nails.

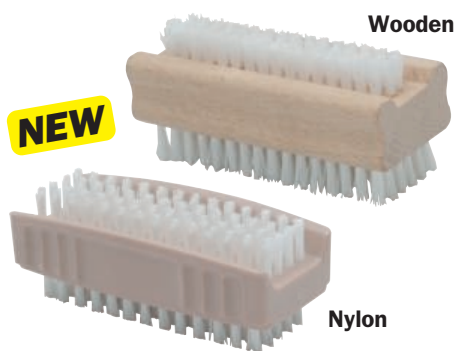

Body Type	Weight each	Order Code COT-907	Price/1 TB
Nylon	35g	-8850K	47.00
Wooden	55g	-8880K	57.00

Toilet Brush Set

Plastic handle with polypropylene fill. Standard traditional turk's head design. Brush and holder set for easy storage.



Type	Weight each	Order Code COT-907	Price/1 TB
Plastic	160g	-2560K	318.00

Lambswool Duster

Extra reach handle. For cleaning blinds, high corners, bookcases etc.



Overall Length	Weight each	Order Code COT-907	Price/1 TB
1200mm/47"	200g	-4800K	464.00

Suede Brush

Using the finest brass bristles. It's suitable for removing dust and increasing the nap of the suede. It can also be used to clean electrical contacts and spark plugs.



Length	Weight each	Order Code COT-907	Price/1 TB
160mm	41g	-2655K	165.00



Soft traditional yellow duster. 100% natural cotton with sewn edges.

Size: 510 x 400mm.

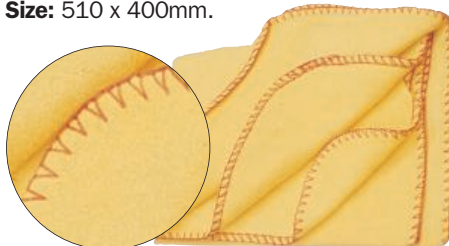

Weight per 10	Order Code KEN-907	Price/1 TB
300g	-4090K	205.00

Floorcloths

General-purpose open knit mixed fibre floor cloth. Supplied in packs of 10.

Size: 480mm x 460mm.

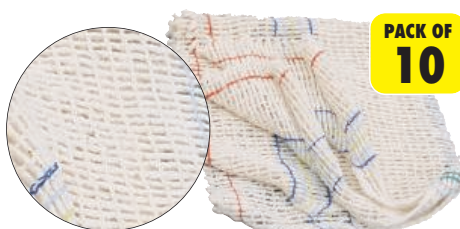

Weight per 10	Order Code KEN-907	Price/Pk TB
500g	-4040K	514.00

Tea Towel

Traditional plain cotton tea towel for general-purpose use.

Size: 510 x 760mm.

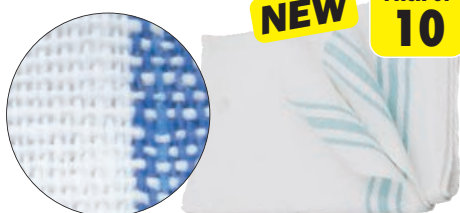

Weight each	Pack Quantity	Order Code COT-907	Price/Pk TB
340g	10	-4900K	599.00

Premium Microfibre Cloths

Non-abrasive cloths that dust, shine and much more.

Cloth size: 40 x 40cm.



Type	Order Code COT-907	Price/1 TB
Premium (56g)	-6963K	85.00

Cellulose Sponge

Size: 140 x 100 x 25mm yellow cellulose sponge.



Weight each	Order Code COT-907	Price/1 TB
70g	-8080K	155.00

Stockinette Roll

100% cotton stockinette roll, can be cut to length as required. Good economical format which can be used for a wide variety of cleaning tasks. 300mm wide x 8.5m in length.



Weight each	Order Code KEN-907	Price/1 TB
830g	-4050K	405.00

Genuine Chamois Leather

Size: 60 x 30cm.



Weight each	Order Code KEN-907	Price/Pk TB
60g	-4130K	878.00

Synthetic Chamois Leather

Fully reusable and highly absorbent synthetic chamois. Soft and gentle on any surface and suitable for many tasks ranging from cars, boats, glass, furniture, tiles, kitchens etc.

Size: 400 x 400mm.



Weight each	Order Code KEN-907	Price/1 TB
60g	-4110K	229.00

Jumbo Sponge

Size: 200 x 100 x 70mm yellow jumbo sponge.



Weight each	Order Code KEN-907	Price/1 TB
35g	-4150K	75.00

JANITORIAL & HYGIENE

GROUP 907 BRUSHWARE & CLEANING PRODUCTS

COTSWOLD Complete Brooms
BRUSHWARE & CLEANING

Top quality brooms. Coco broom heads are ideal for indoor domestic use, whilst bassine is more suitable for heavier industrial uses. Supplied with handles clipped to the head for quick and easy self-assembly.

NEW



Handle Length	Description	Order Code COT-907	Price/1 TB
48"	12" Coco	-1260K	294.00
	12" Bassine	-1200K	308.00
	18" Coco	-1270K	411.00
	18" Bassine	-1210K	464.00
	24" Coco	-1280K	464.00
60"	24" Bassine	-1220K	514.00
	12" Coco	-8980K	335.00
	12" Bassine	-8950K	361.00
	18" Coco	-8990K	552.00
	18" Bassine	-8960K	567.00
	24" Coco	-9000K	644.00
	24" Bassine	-8970K	670.00

Replacement Broom Heads Only

For broom handles see next page.

Description	Hole Dia.	Order Code COT-907	Price/1 TB
12" Coco	15/16"	-8120K	205.00
12" Bassine	15/16"	-8130K	217.00
18" Coco	1 1/8"	-8180K	308.00
18" Bassine	1 1/8"	-8190K	320.00
24" Coco	1 1/8"	-8240K	411.00
24" Bassine	1 1/8"	-8250K	428.00
Brush Stabiliser Bar		-8560K	102.00

Stale Holder

Will fit all flat back brooms listed above. The stale holder is fixed in place two 10" x 3/4" pozi pan screws (supplied).

NEW



Type	Order Code COT-907	Price/1 TB
Stale Holder	-2580K	205.00

Litter Picker

990mm (39") Reach

Using the Cotswold litter picker removes the need to repeatedly bend and stoop to collect litter, helping to reduce back strain and fatigue. The aluminium pole with spring-loaded trigger and jaws ensures that the Cotswold litter picker is as lightweight as possible, so that it is comfortable to use one-handed over extended periods of time.

Jaw capacity: 110mm.
Overall length: 990mm (39").



Reach (mm)	Order Code COT-907	Price/1 TB
990	-1800K	1060.00

Poly Yard Broom c/w Aluminium Handle

Polypropylene bristle yard brush with aluminium handle. Ideal for sweeping leaves and dirt from small yards and pathways.

Overall length: 1290mm.
Width: 290mm.



Width	Order Code COT-907	Price/1 TB
290mm	-8010K	926.00

Sweeping Mops

High quality acrylic head covers for superb performance on parquet/wood floors, tiles and lino floors. Universally jointed zinc plated head frame, beechwood handle.

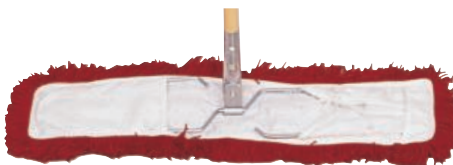

Overall Length	Order Code COT-907	Price/1 TB
Complete Mop		
460mm (18")	-2700K	1627.00
610mm (24")	-2720K	1857.00
Replacement Sleeves		
460mm (18")	-2760K	712.00
610mm (24")	-2780K	747.00

Ribbed Nylon Door Mats

With grippa backing to prevent movement under foot. Hard wearing.



Size	Weight each	Order Code COT-907	Price/1 TB
75 x 44cm	825g	-5140K	734.00

Coir Fibre Door Mats

With bound edges.



Type	Size	Order Code COT-907	Price/1 TB
No.3	76 x 46cm	-5030K	670.00
No.4	84 x 51cm	-5040K	1035.00

Aluminium Long Handled Plastic Dustpan & Brush Set

Angled brush head and extra long 800mm handle allows floors to be swept without bending. Aluminium handles, metal pan and synthetic bristles. Clips together for easy storage. Pan has rubber contact lip.

NEW



Handle Length	Order Code COT-907	Price/1 TB
800mm	-4640K	617.00

Bannister Hand Brushes

With contoured beechwood handles.



NEW

Type	Weight each	Order Code COT-907	Price/1 TB
Natural Coco	140g	-0770K	78.00
Bassine	150g	-0720K	102.00

Heavy Duty Large Dustpan & Brush Set

The plastic dustpan has a deep back to stop dirt falling out when in use and has a serrated edge to enable dirt to be removed easily from the hand brush.



Pan Dimensions (W x L x H)	Order Code COT-907	Price/1 TB
330 x 250 x 90mm	-4560K	411.00

Hooded Metal Dustpan

Riveted metal construction with loop handle. Hooded design, ideal for collecting and retaining dirt and debris.



Width	Order Code COT-907	Price/1 TB
335mm	-4670K	524.00

Metal Hand Shovel

Wooden handle, painted finish, medium duty. **Pan width:** 180mm.



Width	Order Code COT-907	Price/1 TB
180mm	-4710K	280.00

JANITORIAL & HYGIENE

BRUSHWARE & CLEANING PRODUCTS



Stainless Steel Squeegees

For rapidly removing water from windows for a smear-free finish. Ribbed rubber hand grip, will not slip when wet. Can be fitted to telescopic extension. Spring loaded blade retention allows handle to be positioned anywhere along its length. Replaceable rubber blades.



Blade	Order Code COT-907	Price/1 TB
300mm (12")	-3800K	1423.00
450mm (18")	-3820K	1689.00
Replacement Squeegee Blade		
300mm (12")	-3830K	165.00
450mm (18")	-3840K	261.00

Lambswool Window Washers

Lightweight impact resistant plastic handle, with replaceable and washable non-scratch lambswool sleeve. Can be fitted to a telescopic extension handle.



Size	Order Code COT-907	Price/1 TB
355mm (14")	-3860K	1092.00

Car Wash Brushes

Economy

Soft synthetic bristles with plastic body to prevent damage to car bodywork. Fits 12mm (1/2") diameter hose pipes.



Type	Order Code COT-907	Price/1 TB
Economy	-1100K	490.00

Scrubbing Brush

Single tufted (single heel) pattern. Union mixture.



Length	Weight each	Order Code COT-907	Price/1 TB
8"	180g	-8820K	222.00

Kentucky Mop Heads

Cotton twine with heavy duty stitched centres.



Size	Weight each	Order Code COT-907	Price/1 TB
450g	350g	-2500K	339.00
570g	450g	-2510K	357.00

Mop Handles

To suit above.

Type	Length (mm)	Weight each	Order Code COT-907	Price/1 TB
Aluminium	1250	480g	-2680K	902.00
Beech	1270	600g	-3500K	808.00

Aluminium Mop Bucket

Zinc-plated, with foot operated wringing unit.

Diameter: 290mm.
Height: 285mm.



Capacity	Weight each	Order Code COT-907	Price/1 TB
17ltr	2.00kg	-4200K	3662.00

Rectangular Squeeze Mop Bucket

Impact resistant polypropylene. Colours may vary.



Size (W x L x H)	Weight each	Order Code COT-907	Price/1 TB
230 x 310 x 220mm	640g	-4220K	437.00

SITESAFE Folding Sign

Free-standing, Plastic A-frame folding sign with slip hazard symbol on one side and cleaning in progress symbol on the reverse.

Size: 300 x 600mm.

Height (mm)	Order Code SSF-992	Price/1 TB
600	-0010K	821.00

Mops

Complete Mops

With pure yarn heads.

NEW



Size	Length	Weight each	Order Code COT-907	Price/1 TB
No.10	122cm (48")	540g	-9050K	299.00
No.10	152cm (60")	650g	-9060K	325.00
No.12	122cm (48")	540g	-9100K	399.00
No.12	152cm (60")	650g	-9110K	425.00

Replacement Socket Mop Heads

For wet use. Highly absorbent. Pure yarn. Galvanised socket.

Size	Weight each	Order Code COT-907	Price/1 TB
No.10	140g	-8900K	129.00
No.12	170g	-8910K	155.00

Mop & Broom Handles only

Replacement wooden handles for mops and brooms.



Length x Diameter	Weight each	Order Code COT-907	Price/1 TB
48" x 15/16"	340g	-8720K	129.00
48" x 1 1/8"	500g	-8730K	155.00
60" x 15/16"	450g	-8760K	181.00
60" x 1 1/8"	660g	-8770K	205.00

Galvanised Mop Bucket

Heavy duty with perforated drainer. **Width:** 240mm. **Length:** 330mm. **Height:** 230mm.



NEW

Capacity	Weight each	Order Code COT-907	Price/1 TB
13.5ltr	1.70kg	-4210K	1200.00



PRODUCTS ARE ONLY AVAILABLE VIA YOUR DISTRIBUTOR



Colour-Coded Brushware

Colour coding helps to reduce the occurrence of cross contamination, reduces the risk of bacteria transfer between work areas and improves general hygiene practises. Mops, buckets, handles, brooms, brushes, cloths and wipes can all be colour coded for the work place. Understanding a hygiene colour coding system can form part of an employees basic training.



RED - most commonly used in high risk areas such as restrooms and toilets, urinals and washroom floors.



YELLOW - most commonly used in medium risk areas such as washroom sinks and counters, wall tiles, mirrors and metal fitments (hardware etc.)



BLUE - general use in lower risk areas (excluding food preparation and serving areas).



GREEN - general use in food preparation and serving areas, bars - any place where food or drinks are made or served.



12" Stiff Poly Yard Broom Head

Stiff bristles suitable for wet or dry use. Long pile for cleaning uneven/rough surfaces. Moulded handle socket. Suitable for use with aluminium threaded handles (supplied separately - see next page).



Colour	Order Code COT-907	Price/1 TB
Red	-5820K	398.00
Blue	-5800K	398.00

12" Stiff Poly Sweep Broom Head

Stiff bristles suitable for wet or dry use. Medium pile for general-purpose use. Moulded handle socket suitable for use with aluminium threaded handles (supplied separately - see next page).



Colour	Order Code COT-907	Price/1 TB
Red	-5720K	292.00
Yellow	-5730K	292.00
Blue	-5700K	292.00
Green	-5710K	292.00

12" Stiff Poly Deck Broom Head

Stiff bristles suitable for wet or dry use. Short pile for scrubbing heavily soiled areas. Moulded handle socket. Suitable for use with aluminium threaded handles (supplied separately - see next page).



Colour	Order Code COT-907	Price/1 TB
Red	-5320K	372.00
Yellow	-5330K	372.00
Blue	-5300K	372.00
Green	-5310K	372.00

12" Soft Poly Broom Head

Soft broom head suitable for dry use. Short pile for sweeping heavily soiled areas. Moulded handle socket. Suitable for use with aluminium threaded handles (supplied separately - see next page).



Colour	Order Code COT-907	Price/1 TB
Red	-5770K	292.00
Yellow	-5780K	292.00
Blue	-5750K	292.00
Green	-5760K	292.00

Plastic Dustpan & Brush Sets

265mm brush with firm synthetic bristles and 223mm wide dustpan. Clips together for convenient storage.



EXTENDED RANGE

Colour	Order Code COT-907	Price/1 TB
Red	-4600K	150.00
Yellow	-5620K	122.00
Blue	-5600K	122.00
Green	-5610K	122.00

Hand Scrubbing Brush

Stiff bristled brush for removing stubborn stains and cleaning. Figure 8 style body with recessed centre 1/3 for reduced friction. Suitable for floors walls and hard surfaces.



Colour	Order Code COT-907	Price/1 TB
Red	-5670K	239.00
Yellow	-5680K	239.00
Blue	-5650K	239.00
Green	-5660K	239.00

Soft Crimp Poly Handle Brushes

Soft brushes suitable for dry use. Wide oval handle for optimal user comfort. Hanging hole for storage or for clipping to a tool belt for safety when using steps or ladders.



Colour	Order Code COT-907	Price/1 TB
Red	-5370K	213.00
Yellow	-5380K	213.00
Blue	-5350K	213.00
Green	-5360K	213.00

JANITORIAL & HYGIENE



Synthetic Mop Heads

Traditional mop heads with screw fitting socket centre. Suitable for use with traditional style mop buckets. Suitable for cleaning in an autoclave. Synthetic yarn is scientifically developed for improved absorbency, higher durability and less shrinkage.



Colour	Order Code COT-907	Price/1 TB
Blue	-6700K	383.00
Green	-6710K	381.00
Red	-6720K	383.00
Yellow	-6730K	383.00

Aluminium Threaded Handles

Lightweight tubular aluminium handle. Suitable for use with synthetic mop heads and poly broom heads (see opposite page). With moulded finger grip handle.

Overall length: 1400mm.
Diameter: 22.5mm.



Colour	Order Code COT-907	Price/1 TB
Blue	-5250K	266.00
Green	-5260K	266.00
Red	-5270K	266.00
Yellow	-5280K	266.00

Oval Plastic Mop Bucket

All plastic design. I-beam handle design for maximum strength with reduced weight. Removable lid with integral perforated drainer.

Capacity: 15ltr.



Colour	Order Code COT-907	Price/1 TB
Blue	-5550K	424.00
Green	-5560K	424.00
Red	-5570K	424.00
Yellow	-5580K	424.00

Synthetic Kentucky Mop Heads

Stayflat mop heads with easy fit close knit neck. Suitable for use with Kentucky mop handle. Also suitable for cleaning in an autoclave. Synthetic yarn is scientifically developed for improved absorbency, higher durability and less shrinkage.



Handles are supplied separately and should be ordered to match the colour code of the mop head please see below.



Colour	Order Code COT-907	Price/1 TB
Blue	-5450K	372.00
Green	-5460K	372.00
Red	-5470K	372.00
Yellow	-5480K	372.00

Alloy Kentucky Mop Handles

With quick release mop head lever for maximum productivity. With moulded finger grip handle. For use with mop heads shown above.

Overall length: 1480mm.
Diameter: 22.5mm.



Colour	Order Code COT-907	Price/1 TB
Blue	-5400K	398.00
Green	-5410K	398.00
Red	-5420K	398.00
Yellow	-5430K	398.00

Kentucky Mop Bucket

I-beam handle design for maximum strength with reduced weight. Removable drainer with handle compression.

Four castors for easy manoeuvrability.

Capacity: 24ltr.



NEW

Colour	Order Code COT-907	Price/1 TB
Blue	-1722B	4500.00
Green	-1724D	4500.00
Red	-1726F	4500.00
Yellow	-1728H	4500.00

Microfibre Cloth

Multi-purpose microfibre cloths that can be used dry, dampened with water or cleanser. Non-abrasive.

Size: 40 x 40cm.



NEW

Colour	Order Code COT-907	Price/1 TB
Blue (36g)	-6962K	65.00
Green (36g)	-6964K	47.00
Red (36g)	-6966K	47.00
Yellow (36g)	-6968K	47.00

Synthetic Cloths

Impregnated with Triclosan that will not wash out of the fibres. Triclosan prevents growth of most common bacteria such as listeria, e-coli and salmonella. Synthetic yarn is scientifically developed for improved absorbency, higher durability and less shrinkage.

NEW



Colour	Order Code COT-907	Price/1 TB
Blue	-6900K	45.00
Green	-6910K	45.00
Red	-6920K	45.00
Yellow	-6930K	45.00

JANITORIAL & HYGIENE



Black Refuse Sacks

Heavy duty bags bulk packed for industrial use. Available in a choice of five gauge thicknesses.

Dimensions:
46 x 74 x 100cm (18" x 29" x 39").



Thickness (Gauge)	Pack Qty	Order Code AVN-918	Price/Pk TB
140 Gauge	200	-0070K	1187.00
160 Gauge	200	-0150K	1401.00
180 Gauge	200	-0080K	1751.00
225 Gauge	200	-0240K	3151.00
350 Gauge	100	-0090K	1494.00

Black Refuse Sacks - On a Roll

Economical extra strong recycled polythene refuse sacks. Suitable for domestic and office use.

Dimensions:
46 x 74 x 86cm (18" x 29" x 34").



Thickness (Gauge)	Bags per Roll	Order Code AVN-918	Price/1 TB
120 Gauge	20	-0160K	117.00

Woven Polypropylene Sacks

A material made by weaving polypropylene tapes in two directions to form a lightweight breathable fabric suitable for grains, seeds, minerals, sand and other products. Woven polypropylene bags offer the best packaging for a large variety of products in industries such as agriculture, chemical, mining, building materials, and construction. Woven polypropylene bags offer economy, better protection, weight savings, and greater strength than other available packaging. Sold in packs of 100.



Size (mm)	Size	Order Code AVN-918	Price/Pk TB
230 x 310	9" x 12"	-0020K	642.00
310 x 460	12" x 18"	-0030K	817.00
380 x 500	15" x 20"	-0040K	1109.00
460 x 620	18" x 24"	-0050K	1564.00
620 x 1000	24" x 40"	-0060K	2801.00

Wheelie Bin Liners

Heavy gauge refuse sacks. Specifically designed for use with wheelie bins.

PACK OF 100



Size (inch)	Thickness (Gauge)	Order Code AVN-918	Price/Pk TB
20 x 35 x 47"	350	-0210K	2813.00
30 x 45 x 54"	150	-0220K	3035.00
30 x 46 x 54"	180	-0200K	2323.00
30 x 50 x 54"	180	-0230K	2918.00

Compactor Sacks

Extra large and heavy gauge for use with bulk disposal of refuse including larger objects.

Dimensions (W x L x H): 51 x 86 x 120cm.

PACK OF 100



Thickness (Gauge)	Pack Qty	Order Code AVN-918	Price/1 TB
300g	100	-0250K	2393.00



Plastic & Galvanised Dustbins

80ltr capacity. Designed for domestic and commercial use. Plastic bins are not suitable for use with hot ashes or large, sharp swarfs.

Diameter: 450mm.



Type	Weight each	Order Code KEN-907	Price/1 TB
Plastic	2.8kg	-9050K	1029.00
Galvanised	4.1kg	-9000K	1822.00

Coloured Refuse Sacks

Heavy gauge refuse sacks. For colour coded disposal systems. Available in a choice of four colours.

Dimensions: 46 x 74 x 100cm (18" x 29" x 39").

PACK OF 100



Colour	Thickness (Gauge)	Order Code AVN-918	Price/Pk TB
Red	160g	-0100K	2334.00
Yellow	160g	-0120K	2334.00
Blue	160g	-0130K	2334.00
Green	160g	-0110K	2334.00



Cigarette Butt/Ash Bin - Wall Mounted

Stainless steel bins are practically designed for the safe and efficient disposal of cigarette butts and the unsightly litter caused by cigarettes. Fully weather-resistant and ideal for use in designated smoking areas.

Specification: Lockable hinged front. Supplied with wall fixings.

Dimensions (W x H x D):

265 x 285 x 110mm.

Capacity: 3ltr.



Type	Order Code MTL-907	Price/1 TB
Mounted Cigarette Bin	-8120K	2059.00

JANITORIAL & HYGIENE

SOLENT™ **Sanitise Wipes**
CLEANING & HYGIENE

A single use wipe for sanitising all types of surfaces. Impregnated with a fast acting disinfectant that has a high kill rate, effective against most bacteria including C.Diff. Tub of 200 (20 x 30cm) wipes and bucket of 1000 (20 x 20cm) wipes.



Quantity	Order Code	Price/1 TB
200	SOL-930	876.00
1000	-5200K	1751.00

Paint & Mastic

A soft hand and surface wipe, ideal for removing non-cured petroleum based products such as paint, adhesives and mastics.



PACK OF 150

Quantity	Order Code	Price/1 TB
150	SOL-930	992.00

Multi

A soft hand and surface wipe, ideal for removing grease, grime, oil, tar, ink and general dirt.

Tub contents: 150 (28 x 28cm) wipes.



PACK OF 150

Quantity	Order Code	Price/1 TB
150	SOL-930	788.00

SOLENT™ **Engineer's Wipes**
CLEANING & HYGIENE

High Performance Work Wipes

For removing the thickest of grease and grime. Designed for use by mechanics, engineers, printers, electronics industry etc. Very low lint - solvent resistant - high wet strength - silicone free. Smaller sheet size for reduced cost per wipe. Fabric type: 48% polyester, 52% wood pulp, spun lace with light aperture. Total cloth area = 24.3m².



Box Qty	Colour	Pack Weight	Order Code	Price/1 TB
250	White	1.36kg	SOL-930	1401.00

A1 Coloured Wipes

Strong/economical wipes. **Pack weight:** 10kg. Manufactured from recycled material



Grade	Colour	Order Code	Price/1 TB
Industrial	Multi	SOL-930	464.00

Hand Wipes

Soft white wipes. Removes oil, grease, ink and general dirt. Waterless - no need to rinse hands after cleaning. Ideal for mobile repair and maintenance vans and use around the workshop.



PACK OF 150

Pack Qty	Order Code	Price/Pk TB
150	SOL-930	882.00

Heavy Duty Hand Wipes

Impregnated with mild abrasive fibres to remove oil, grease, general grime plus difficult to remove contaminants such as paints, sealants, most inks and ground-in dirt. A genuine waterless hand cleaning wipe with no need to rinse after use, ideal for mobile repair and maintenance vans as well as use around the workshop.



PACK OF 100

Pack Qty	Order Code	Price/Pk TB
100	SOL-930	964.00

SOLENT™ **Food Safe Wipes**
HYGIENE FOR FOOD

Hand Wipes

These non-toxic single-use wipes are excellent for killing lethal bacteria and preventing cross-contamination. **Size:** 20 x 30cm.



PACK OF 200

Pack Qty	Order Code	Price/Pk TB
200	SOL-930	759.00

Food Safe Wipes

Probe Wipes

These single-use wipes are for the disinfectant cleaning of food probes to prevent cross-contamination. Tub of 175 (13 x 13cm) wipes.



PACK OF 175

Quantity/ Pk Type	Order Code	Price/1 TB
175 Tub	SOL-930	381.00



GROUP 952 TOILET TISSUE

SOLENT™ 'Stroll' Mini Jumbo Toilet Rolls
CLEANING & HYGIENE

High quality 2-ply white tissue. Choice of roll lengths to suit all traffic areas, offering maximum economy and flexibility with less time spent refilling. Suitable for away-from-home locations such as commercial premises, restaurants, hotels and pubs, factories and offices. Lockable dispensers help to keep the product clean and discourage pilfering. Use with MTD003 Mini Jumbo dispensers.



2 Ply
Each Roll 200m
12 Rolls per Case

Description	Roll Size	Rolls/Case	Core Size	Order Code SOL-952	Price/Pk TB
M-Stroll Mini Jumbo	90mm x 200m	12	60mm	-3300Y	1288.00
M-Stroll Mini Jumbo			76mm	-3320Z	1288.00

'Stroll' MTD003 Mini-Jumbo Dispenser

Durable white ABS dispensers. Supplied with keys.



Dispenser Description	Roll Size	Order Code SOL-952	Price/1 TB
Mini Jumbo	90mm x 200m	-9200E	1391.00

SOLENT™ 'Stroll' Jumbo Toilet Rolls
CLEANING & HYGIENE

High quality 2-ply white tissue. Offering maximum economy and flexibility with less time spent refilling. Suitable for away-from-home locations such as commercial premises, restaurants, hotels and pubs, factories and offices. Lockable dispensers help to keep the product clean and discourage pilfering. Use with JTD001 Jumbo dispensers.



2 Ply
Each Roll 400m
6 Rolls per Case

Description	Roll Size	Rolls/Case	Core Size	Order Code SOL-952	Price/Pk TB
J-Stroll Jumbo Roll	400m	6	57mm	-3200W	1288.00

JTD001 'Stroll' Jumbo Toilet Roll Dispenser

Durable white ABS dispensers. Supplied with keys.



Dispenser Description	Roll Size	Order Code SOL-952	Price/1 TB
Jumbo	410m	-9150D	1698.00

SOLENT™ 'Flat Pack' Interleaved Toilet Tissue
CLEANING & HYGIENE

High quality 2-ply white tissue. 'One sheet at a time' dispensing discourages pilfering and minimises wastage. Use with FTD119 dispenser, which can be topped up at any time.

Sheets per sleeve: 250.
Sleeves per pack: 36.



2 Ply
9000 Sheets Per Case

Description	Sheets/Case	Order Code SOL-952	Price/Pk TB
2-ply White Interleaved	9000	-2200A	1957.00

FTD119 'Flat Pack' Dispenser

Durable white ABS dispenser. Lockable with keys provided.



Description	Order Code SOL-952	Price/1 TB
Flat Pack Dispenser	-9100C	1288.00

SOLENT™ Toilet Rolls
CLEANING & HYGIENE

S-T-Roll

High quality 2-ply white toilet tissue. Suitable for domestic and professional use.

Standard Roll

Sheets per roll: 200.



NEW

2 Ply
200 Sheets Per Roll
36 Rolls per Case

Description	Rolls/Case	Order Code SOL-952	Price/Pk TB
Standard S-T-Roll	36	-3350K	773.00

SOLENT *CLEANING & HYGIENE* **Interfold Towels**

High quality paper towels. For the most cost efficient and hygienic solution to hand drying. When the towel is pulled out the next towel is presented for use - eliminates problems associated with cross contamination of towels in medical and food industry applications. Small towel size minimises cost and waste. Can be topped up during use - need never run out.

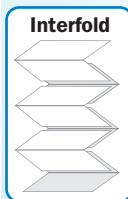
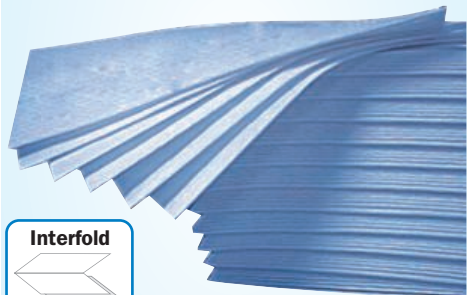

1 Ply
3600 Towels Per Case

Type	Colour	Sheet Size (cm)	Pack Qty.	Order Code SOL-952	Price/Pk TB
1-Ply	Blue	21 x 24.7	3600	-2700M	1868.00
1-Ply	Blue	24.5 x 22	3600	-2680A	2043.00

C-Fold Hand Towels

'Soft' has maximum softness and absorbency, designed for use in washrooms where disposal bins are provided. Single-sheet dispensing discourages pilfering and minimises wastage. Use with CTD201 dispenser, which can be topped up at any time.

Sheet size: 22.5 x 33cm.

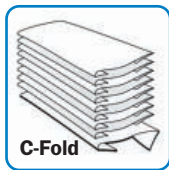
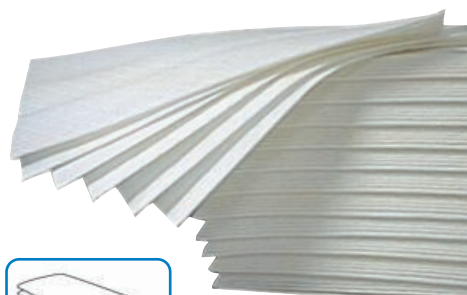

2 Ply **Soft Bin Disposal** **2400 Towels Per Case**

Description	Colour	Pack Qty.	Order Code SOL-952	Price/Pk TB
'Soft' 2-Ply	White	2400	-2600K	2218.00

Folded Towel Dispenser CTD201

Durable white ABS dispensers. Lockable with keys provided. For use with 'Z-Fold', 'Interfold' and 'C-Fold' towels.



Description	Model Number	Order Code SOL-952	Price/1 TB
Dispenser	CTD201	-9050B	1926.00

Workshop Rolls

'Floorstand' 2-ply

Long lasting 2-ply paper towels. For use with floorstands or similar dispensers. Perforated and unperforated. Unperforated - cut to size to suit application. Suitable for workshops, food processing and automotive industries.

2 Ply



Description	Roll Size (cm x m)	Pack Qty	Order Code SOL-952	Price/Pk TB
White Perf	28 x 290	2	-2730M	2292.00
White Perf	28 x 360	2	-2790D	2276.00
Blue Perf	23 x 350	2	-2760A	1751.00
Blue	26 x 400	2	-2800N	2112.00
White	26 x 400	2	-2805K	2070.00
Blue	37 x 400	1	-2830Q	1674.00

Wheel Mounted Floor Stand Roll Dispenser

Highly improved design now features large diameter castors providing maximum portability even when fully loaded and when moving over uneven ground. A self-adjusting cutting edge allows the wiper to be precisely and squarely torn off with the minimum of effort. Suitable for use with Solent multi-purpose wiper rolls as well as many other brands. Folds flat for storage when not in use.



Maximum Roll Width	Weight each	Order Code SOL-952	Price/1 TB
30cm	2.1kg	-9400W	2733.00

High Quality 100% Tissue Wipes

Wiper Box

Thick, bulky and strong paper wipes. High performance yet incredibly economical wiping solution, ideal for surface wiping, mopping spills cleaning tools and equipment and process wiping. Suitable for factory workshops, valeting, maintenance automotive and agricultural industry.

Sheet size: 40 x 26cm.
Sheets per box: 400.

2 Ply **Wiperbox**
400 Sheets Per Box
Highly Absorbent



Colour	Roll Size	Order Code SOL-952	Price/Pk TB
White	26cm x 160m	-3480D	927.00

General Purpose Rolls

'Hygiene' 1 Ply

Long lasting single-ply paper towels. Medium duty for catering and general hygiene use. Unperforated - cut to size to suit application. Supplied in cases of 16 rolls.

1 Ply

Each Roll 70m Unperforated

12 Rolls per Case

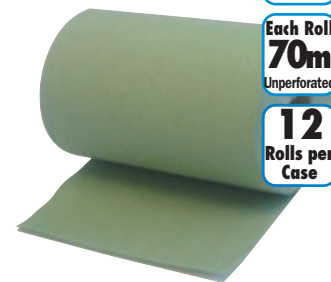

Description	Roll Size (cm x m)	Pack Qty	Order Code SOL-952	Price/Pk TB
Hygiene Roll	20 x 70	16	-2900Q	2743.00

Heavy Duty Perforated Rolls

'Hygiene' 2-ply

Highly absorbent two ply paper towels. High strength and 25cm sheet width for general hygiene use.

Also suitable for light workshop, industrial, medical and veterinary applications where a stronger towel is required.

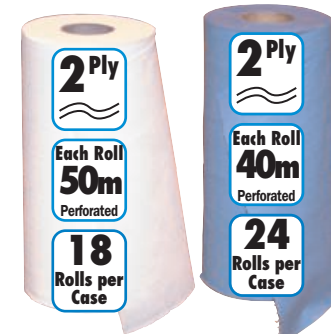

Colour	Roll Size (cm x m)	Pack Qty	Order Code SOL-952	Price/Pk TB
Blue	25 x 40	24	-2950R	2575.00
White	25 x 50	18	-2960S	2575.00

Centre-Feed Rolls

Available as single ply wipes suitable for general wiping or as two ply heavy duty wipes. Supplied on rolls with a removal cardboard core to allow them to be used either as centre feed rolls in a dispenser or with the core still in place on a floor stand. Ideally suitable for all workshop and most general industrial and automotive object wiping applications. Each roll is perforated for easier dispensing of each sheet. Available as blue or white rolls in different roll widths and lengths.

1 Ply

2 Ply

6 Rolls per Case



Type	Colour	Roll Size (cm x m)	Order Code SOL-952	Price/Pk TB
2-ply	White	19.0 x 150	-2500G	1685.00
2-ply	Blue	19.0 x 150	-2550H	1685.00
1-ply	White	23.0 x 288	-2555Q	2451.00
2-ply	Blue	19.5 x 144	-2560S	1693.00
2-ply	White	19.5 x 144	-2570T	1898.00



GROUP 800 ARCHIVE BOXES

Page **680**

GROUP 801 ORGANISERS

Page **681**

GROUP 802 CLOCKS

Page **684**

GROUP 803 COMPUTER CLEANERS

Page **681**

GROUP 804 COMPUTER MEDIA

Page **680**

GROUP 810 FILING

Page **680**

GROUP 811 CHAIRS

Page **682**

GROUP 820 SECURITY & SAFES

Page **683**

GROUP 825 CALCULATORS

Page **684**

GROUP 827 NOTE BOOKS & PADS

Page **680**

GROUP 828 FANS & HEATERS

Page **685**

GROUP 836 PRESENTATION & CONFERENCE

Page **686 - 687**

GROUP 837 POLYTHENE

Page **688**

GROUP 837 BANDING & STRAPPING

Page **690 - 691**

GROUP 838 STAPLERS

Page **692**

GROUP 840 TRIMMERS & GUILLOTINES

Page **692**

GROUP 844 WEIGHING SCALES

Page **693**

GROUP 956 PROTECTIVE SLEEVING

Page **694**

GROUP 979 TAPE DISPENSERS

Page **695**

GROUP 980 MASKING TAPES

Page **698**

GROUP 981 BONDING TAPES

Page **698**

GROUP 981 INDUSTRIAL TAPES

Page **697**

GROUP 981 MESSAGE TAPES & LABELS

Page **696**

GROUP 981 PACKAGING TAPES

Page **696**

GROUP 982 SAFETY KNIVES

Page **699**



OFFICE SUPPLIES & PACKAGING

**Product Groups
787 - 982**

Product Grading



Production

High performance industrial tooling designed for continuous use applications on machine tools where repeatability and long tool life are of critical importance.



Professional

Industrial tooling that has enhanced features and benefits demanded by craftsmen and professional users.



Industrial

Designed for regular use in industrial applications. Manufactured to stringent quality levels and international standards.



Workshop

Standard quality tooling for use by tradesmen and generally industrial use.



Maintenance

Products designed for general maintenance of machines, workshops, garages and some household applications.



Home Improver

DIY quality tooling. Designed for home use and light industrial applications.

Contents OFFICE SUPPLIES

Description	Group	Page
Archive Boxes & Storage	800	680
Banding, Strapping & Accessories	837	690 - 691
Bonding Tapes	981	698
Calculators	825	684
Catering Appliances	787	685
Clipboards	788	680
Clocks	802	684
Computer Cleaners	803	681
Computer Media	804	680
Filing - Punched Pockets	810	681
Heaters	811	685
Industrial Tapes	981	697
Masking Tapes	980	698
Message Tapes	981	696
Notice Boards	836	686
Note Books & Pads	827	681
Office Chairs	807	682
Organisers	801	681
Packaging - Polythene	837	689
Packaging Tapes	981	696
Protective Sleeving	956	694
Safety Knives	982	699
Security - Key Cabinets	820	683
- Key Rings	820	683
- Mirrors	820	683
- Safes	820	683
Snap Frames & Easels	836	686
Staplers - Office	838	692
Tape Dispensers	979	695
Trimmers & Guillotines	840	692
Weighing Scales	844	693
Whiteboards	836	687
Whiteboard Cleaners	836	687
Markers	836	687
Tapes & Magnets	836	687

GROUP 800 STORAGE/FILING

AVON Archive Boxes

Rigid cardboard box with carrying handles and attached lid to prevent loss/damage. Suitable for storage and transportation of large quantities of non-active records. Suitable for stacking. Large contents panel for clear labelling and easy retrieval.

Dimensions (W x H x D):
430 x 360 x 257mm.



PACK OF 10

Colour	Order Code	Price/Pk TB
Brown	AVN-801	1751.00

Offis USB 2.0 Flash Drives

Very quick and simple to use and compatible with both PCs and Macs. Simply plug the device into your USB port and you can transfer files or run presentations in an instant. On the majority of computers the USB Flash Drive is plug and play.

Features:

- Plugs into any USB port.
- Hi-speed USB 2.0.
- Locking function.
- Fits on your key ring or in your pocket.



Size	Order Code	Price/1 TB
4GB	OFI-804	411.00
8GB	-1820K	617.00

Offis A4 Punched Pockets

A4 top opening. Manufactured from hard-wearing anti-static polypropylene and lightly embossed to reduce glare. Heavy duty reinforced binding edge with conventional 11 hole punch which fits all 2, 3 and 4-ring binders. Ideal for everyday use.

PACK OF 100



Size	Pack Quantity	Order Code	Price/Pk TB
A4	100	OFI-804	197.00

Pocket Note Book

Stiff cover note book with fitted elastic band. 80 leaves, feint ruled.

Size: 83 x 127mm.



Size (mm)	Order Code	Price/1 TB
83 x 127	OFI-827	45.00

PVC Clipboards

Keeps paper firmly in place. Rigid PVC covered board with heavy duty clip. Suitable for foolscap and A4 papers. Fold over clipboard has an inside pocket for protecting papers.



A4 FOOLSCAP

*Colours in table are for guidance only.

Colour	Type	Order Code	Price/1 TB
Black	Single	OFI-804	129.00
Blue	Single	-1725K	129.00
Red	Single	-1730K	129.00
Black	Foldover	-1740K	155.00
Blue	Foldover	-1745K	155.00
Red	Foldover	-1750K	155.00

Masonite Clipboards

Masonite clipboards are manufactured from strong brown hardboard with a glazed front to provide a smooth writing surface. Heavy duty clip ensures that papers are held secure. Ideally suitable for stores, warehouse, stocktaking and inspection procedures.



A3 A4

Size	Order Code	Price/1 TB
A4	OFI-804	155.00
A3	-1700K	221.00

Organiser & Business Card Holder

Personal Organiser:

PVC leather-look padded organiser. Six internal pockets and press stud fasten. Complete with 20 leaved lined A4 pad. Pen and pen holder.

+ Business Card Holder:

PVC leather-look padded holder. Organise, store and view up to 96 cards.

Size (H x W x D): 200 x 120 x 17mm.

= Set:

1x organiser and 1x business card holder.



A4

Type	Order Code	Price/1 TB
Organiser & Holder	OFI-804	456.00

Business Bag

Polyurethane leather-look business bag which is fully padded for laptop carrying. Has a rear file section, three large internal compartments, comfortable handle and detachable shoulder strap. Also features an exterior zip organiser.



Type	Order Code	Price/1 TB
Business Bag	OFI-804	1799.00

OFFICE SUPPLIES & PACKAGING

SOLENT OFFICE CLEANING & HYGIENE
Dry Absorbent Wipes

Essential for mopping up desktop spills fast! Tough and very absorbent. Safe to use on most screens as the material has a low lint content and will not scratch. Use able with all cleaning fluids and foams.

PACK OF 50



Order Code SOL-780	Price/1 TB
-6840E	186.00

Whiteboard Cleaner

Cleans like new! Effectively cleans dry wipe marker pen from most whiteboards. Non-toxic, non-hazardous fluid. Leaves whiteboards looking new. 250ml spray bottle. Use with Solent Dry Wipe Cloths (SOL-780-6840E) available separately.



Order Code SOL-780	Price/1 TB
-7000A	140.00

Whiteboard Wipes

Pre-moistened whiteboard wipes effectively cleans dry wipe marker pen from most whiteboards. Non-toxic. Non-hazardous. Leaves whiteboards looking like new.

Tub contents: 100.

PACK OF 100



Order Code SOL-780	Price/Pk TB
-7020C	170.00

Anti-Static Screen Cleaner

Anti-static screen cleaner for use on all screens including TFT, TV and Plasma screens. No alcohol, non-toxic, non-hazardous cleaner and protector. Will reduce build-up of dust and dirt that can cause headaches and eyestrain. 250ml spray bottle. Use with Solent Dry Wipe Cloths (SOL-780-6840E) available separately.



Order Code SOL-780	Price/1 TB
-6860G	140.00

Screen Wipe Hygiene Sachets

Hygienic sachets for use on most screens. No alcohol, non-toxic, non-hazardous cleaner and protector. Will reduce build-up of dust and dirt that can cause headaches and eyestrain. Pack of 50.

PACK OF 50



Order Code SOL-780	Price/Pk TB
-6890K	372.00

Telephone Wipe Hygiene Sachets

Effectively cleans telephones, headsets and any other equipment that comes into contact with ear or mouth. Non-toxic, non-hazardous cleaner. Will help to reduce the build-up of dirt and dust where germs can breed. Pack of 50 sachets.

PACK OF 50



Order Code SOL-780	Price/Pk TB
-6950R	424.00

SOLENT OFFICE CLEANING & HYGIENE
Air Duster

HFC-free. Designed to remove dust and dirt from hard to reach areas. Environmentally friendly, does not contribute to global warming. Extension tube included.

Size: 400ml can.



Order Code SOL-780	Price/1 TB
-6800A	424.00

Anti-static Screen Wipes

Anti-static screen wipes. Pre-saturated for use on screens including TFT, TV and Plasma screens. Will reduce build-up of dust that can cause headaches and eyestrain. Bio-degradable. No alcohol, non-toxic, non-hazardous. Pack of 100.

PACK OF 100



Order Code SOL-780	Price/Pk TB
-6880J	170.00

Multi-Purpose Wipes

Antibacterial multi-purpose wipes. Effectively cleans hard surfaces, computer casing, desks, telephones etc. Antibacterial formulation effective against E-coli, salmonella, MRSA and influenza virus. Helps to reduce build-up of dust and dirt where germs can breed. Pack of 100.

PACK OF 100



Order Code SOL-780	Price/Pk TB
-6920N	140.00

Lincoln

Leather Faced Manager's Chairs

Gas assisted height adjustment and seat base tension control. 3" thick seat and back padding for optimal comfort. Five star base for stability with covered dual wheel castors on each spur for moving seat location. With shaped arm rests.

Colour: black
Maximum weight: 16 stones (101kg).
Dimensions:
High back Seat: D508 x W508mm.
Back: H699 x W508mm.
Seat height: 460mm.
Medium Back Seat: D489 x W536mm.
Back: H508 x W536mm.
Seat height: 460mm.

Medium back

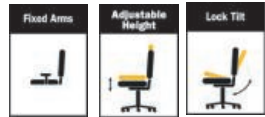

Type	Order Code LNC-811	Price/1 TB
Executive High Back	-0100K	9269.00
Medium Back	-0110K	8239.00

High Backed Manager's Chairs

Fabric covered, high backed, manager's chair. Gas assisted height adjustment and seat base tension control. 3" thick seat and back padding for optimal comfort. Five star base for stability with covered dual wheel castors on each spur for moving seat location. Shaped arm rests for comfort.

Colours: charcoal, royal blue and red.
Maximum weight: 16 stones (101kg).
Dimensions:
Seat: D504 x W539mm.
Back: H628 x W529mm.
Seat height: 460mm.



Colour	Order Code LNC-811	Price/1 TB
Charcoal	-0060K	5923.00
Royal Blue	-0080K	5923.00
Red	-0090K	5923.00

High Back Operator's Chair

Fabric covered, medium backed, operator's chair. Gas assisted height adjustment and seat base tension control. Back height adjustment. 3" thick seat and back padding. Five star base for stability with covered dual wheel castors on each spur for moving seat location. Arm rests available as an optional extra.

Colours: charcoal, royal blue and red.
Maximum weight: 16 stones (101kg).
Dimensions:
Seat: D470 x W486mm.
Back: H501 x W460mm.
Seat height: 460mm.

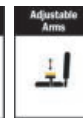

Colour	Order Code LNC-811	Price/1 TB
Charcoal	-0010K	5665.00
Royal Blue	-0030K	5665.00
Red	-0040K	5665.00
Fixed Arms	-0310K	2059.00
Adjustable Arms	-0420K	1650.00

Draughtsman's Chair

Fabric covered, fixed position chair. Five star base for stability.

Colours: charcoal or royal blue fabric colours.
Maximum weight: 16 stones (101kg)
Height adjustable chrome foot ring: (between 200 - 400mm).
Seat height adjustment: (590 - 830mm).
 Medium back with depth adjustment.



Not to be used with castors

Colour	Order Code LNC-811	Price/1 TB
Charcoal	-0120K	5665.00
Royal Blue	-0130K	5665.00

High Industrial PU Chair

Moulded plastic, fixed position chair. Five star base for stability.

Colour: black.
Maximum weight: 16 stones (101kg).
Dimensions: Height adjustable chrome foot ring: 200 - 400mm.
Seat height adjustment: 590 - 830mm.
 Medium back with depth adjustment.



Not to be used with castors

Colour	Order Code LNC-811	Price/1 TB
Black	-0140K	7209.00

Low Industrial PU Chair No Foot Ring

Easy to clean polyurethane ideal for the factory floor, workshop or laboratory.

Colour: black.
Dimensions:
Seat: W460 x D420 x H410 - 530mm.
Back: H310mm.



Colour	Order Code LNC-811	Price/1 TB
Black	-0250K	6179.00

Metal Kick Stools

Fitted with three spring loaded castors for robust maximum mobility. The base ring holds the kick stool rigid to the floor immediately after weight is applied. Heavy duty construction.

Colours: black, blue, grey or red.
Diameter: 29cm.



Colour	Order Code LNC-811	Price/1 TB
Black	-0190K	2450.00
Blue	-0200K	2450.00
Grey	-0210K	2450.00
Red	-0220K	2450.00

Plastic Kick Stool

Manufactured in high quality durable plastic, lightweight and easy to move. Incorporates three sprung loaded castors which retract when weight is applied.

Maximum load: 125kg.



Colour	Order Code LNC-811	Price/1 TB
Black	-0350K	2059.00
Blue	-0360K	2059.00
Grey	-0370K	2059.00
Red	-0380K	2059.00

MATLOCK Electronic Safes

Electronic safe complete with mounting bolts and floor carpet. One fixed shelf. 3 - 8 digit locking code. Concealed emergency manual key lock. Double locking bolts. Fine powder coated finish.



Dimensions (mm)		Order Code	Price/1 TB
Internal	External	MTL-820	
240x340x195	250x350x250	-5020K	3103.00
290x370x245	300x380x300	-5030K	4999.00

Electronic key safe

Electronic key safe with a handy deposit slot - insert keys without opening the cabinet. Supplied with a manual override key, key rings, multi-coloured tags and fixing bolts. Requires 4x AA batteries.



Key Capacity	Dimensions W x D x H (mm)	Order Code	Price/1 TB
48	300 x 100 x 365	-5540K	5665.00

Combination Key Safe

DPC012
Strong, secure, convenient key safe for making keys available for those you trust. Made of steel with a powder coated finish, it has four mounting holes (screws provided) and a weather guard to protect the re-settable 10,000 combination lock.



Size H x W x D (mm)	Order Code	Price/1 TB
118 x 83 x 40	-0500K	2070.00

Emergency Key Cabinet

The Matlock Emergency Key Cabinet is an ideal way to centrally control access to a restricted key for emergency use on site. Supplied with hammer chain to break glass. It is manufactured from heavy gauge steel, with durable piano hinges, and a security lock with two keys.



Type	Order Code	Price/1 TB
Keyed	MTL-820 -0400K	979.00

50 Key Cabinet with Perspex Window

Lockable steel key safe featuring a clear perspex window for easy visual check on keys. Suitable for wall mounting and includes pre-drilled mounting holes and bolts.

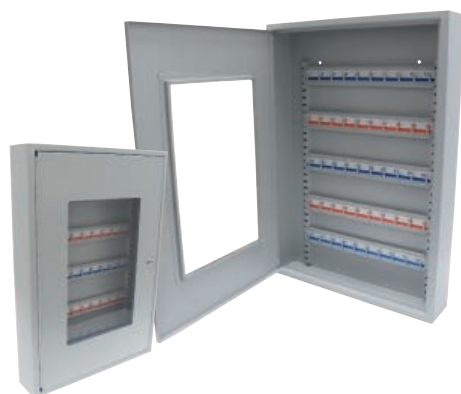

Key Capacity	Dimensions W x D x H (mm)	Order Code	Price/1 TB
50	380 x 80 x 550	-0350K	3827.00

Key Cabinets

All heavy gauge steel construction for secure key storage. Fitted with security lock and supplied complete with two keys. All key hooks are numbered for easier identification. Easily fitted to walls with screws (fixings not supplied).



Key Capacity	Dimensions W x D x H (mm)	Order Code	Price/1 TB
20	160 x 80 x 20	-0200K	514.00
48	180 x 80 x 250	-0250K	823.00
93	240 x 80 x 300	-0300K	1161.00

SAFES/MIRRORS 820

Convex Traffic Safety Mirror

These lightweight convex traffic mirrors are designed to assist road safety and can help eliminate blind spots at corners, concealed entrances and exits, car parks and junctions to ensure maximum visibility. Mirror manufactured from unbreakable polymir with red/white plastic surround.



Type	Order Code	Price/1 TB
Outdoor	MTL-820 -7840K	8999.00

Acrylic Security Mirrors

Internal and external acrylic convex mirrors with fully adjustable fixing brackets. For use in all situations i.e. security, safety, traffic surveillance, Warehousing, car parks, retail business, road way (exit from drive to road.) etc. Each mirror comes complete with wall mounting hardware and instructions for maximum viewing.



Type	Size (mm)	Order Code	Price/1 TB
Interior	400	-8040K	3294.00
Interior	600	-8060K	4621.00
Outdoor	600	-8160K	7209.00

Blue Plastic Key Rings

Manufactured from plastic with a removable address label. Fitted with a metal key ring.



PACK OF 50

Description	Order Code	Price/Pk TB
Key Ring	MTL-820 -9020K	1133.00

PRODUCTS ARE ONLY AVAILABLE VIA YOUR DISTRIBUTOR



Chrome Wall Clock

Traditional 12 hour clock. Analogue display with quartz movement. Requires 1x AA battery, supplied separately - (Order Code EDI-904-3020K - pack of 4). 355mm (14"). Chrome finish rim with white clock face, easy to read extra large black digits, divisions and hands, red second hand. Manufactured to CE requirements. Moulded hanging slot.



Size	Order Code	Price/1 TB
355mm (14")	OFI-823 -0010K	593.00

White Wall Clock

Traditional 12 hour clock. Analogue display with quartz movement. Requires 1x AA battery, supplied separately - (Order Code EDI-904-3020K - pack of 4). 25.4cm (10") Silver finish round rim with white clock face, easy to read black digits, divisions and hands. Moulded hanging slot. Manufactured to CE requirements.



Size	Order Code	Price/1 TB
254mm (10")	OFI-823 -0030K	474.00

24 Hour Clock

254mm (10") dial with a white plastic rim. Large easy to read digits, hands and divisions. Moulded hanging slot for wall mounting. Quartz movement. Requires 1x AA battery (Order Code EDI-904-3020K - pack of 4). Manufactured to CE requirements.



Size	Order Code	Price/1 TB
254mm (10")	OFI-802 -0540K	346.00

EDISON Large Desktop Calculator

DLC 012
3 digit comma marker. Large tilting 12 digit display. Solar with battery back up. **Dimensions (W x H):** 140 x 190mm.



DUAL POWER



Model Number	Order Code	Price/1 TB
DLC012	EDI-801 -6100K	1050.00

Financial Calculator

DFC 036
3 digit comma markers. Large 12 digit displays. Dual power, solar with battery back up. Automatic power off. Flip down stands.

Additional Features:
3 line display. Decimal place selector; 'Floating', '4,2,0 Digits' or 'Add 2 (=Divide by 100)'. Rounding function; 'Round-down' or 'Round-nearest'. Tax (with presettable rate), cost, sell margin, currency (with presettable rate), HMS (time).

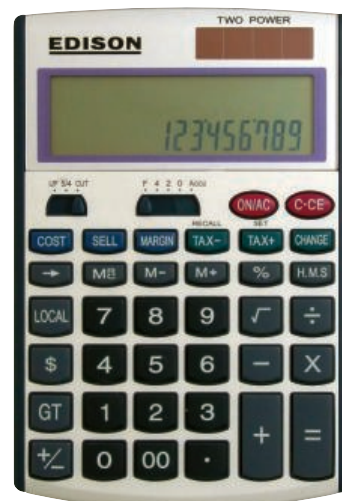

DUAL POWER

Model Number	Order Code	Price/1 TB
DFC036	EDI-801 -5920K	530.00

12-Digit Semi-Desk LCD Calculator

DCS012
General purpose desk calculator with 12 digit LCD display. Includes cost, sell and margin feature and tax function. Solar powered with battery back-up. **Dimensions (W x H):** 98 x 137mm.



DUAL POWER
12 DIGITS

Model Number	Order Code	Price/1 TB
DCS012	EDI-825 -0070K	582.00

NEW

Scientific Calculator

DFC240
Combines a twin line display that shows both the question and the answer with a logical algebraic entry system that allows you to enter calculations in the order they are written. Has 240 functions, automatic power off and slide-on case.

Dimensions (W x H): 83 x 154mm.

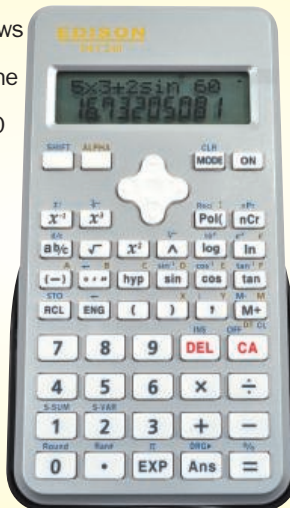

Model Number	Order Code	Price/1 TB
DFC240	EDI-825 -0080K	696.00

NEW

8-Digit Pocket LCD Calculator

PC008
General purpose pocket-sized calculator with 8 digit LCD display. Solar powered with battery back-up. Percentage key. Automatic power off.

Dimensions (W x H): 62 x 102mm.



NEW
DUAL POWER
8 DIGITS

Model Number	Order Code	Price/1 TB
PC008	EDI-825 -0050K	361.00

KOBE Insect Killers

Kobe Insect Killers are a safe and hygienic way to eliminate flying insects. Features a protective outer mesh, low energy consumption and removable tray for easy cleaning. Suitable for suspending from a wall or ceiling. Supplied with hanging chain.

Insect Killer - 20W

Model number: EIK202. **Rated power input:** 20W. **Tube type:** 2x TLD10W. Effective area: 30m². **Replacement tube:** Order Code KBE-787-0150K (for single tube).



Wattage	Effective Area	Order Code	Price/1 TB
20W	30m ²	-0130K	1750.00
40W	60m ²	-0140K	2999.00
20W bulb		-0150K	155.00
40W bulb		-0160K	181.00

Insect Killer with Remote Control - 20W

Bulbs positioned at the top to allow an all round opening. **Model number:** IKR202. **Rated power input:** 20W. Tube type: 2x TLD10W. **Effective area:** 40m². **Replacement tube:** Order Code KBE-787-0150K (for single tube).



Wattage	Effective Area	Order Code	Price/1 TB
20W	40m ²	-0170K	1288.00

Hot Plate

TEC-HP03

Compact and portable hot plate made to current CE specifications. It has cast iron elements and a thermostatic control from simmer to boil in six settings with a durable easy to clean surface. Two hot plates, a 190mm 1.5kW and 160mm 1kW.



2 Hot Plates 1.5kW & 1kW

Rated Power	Colour	Order Code	Price/1 TB
2.5kW	White	-0090K	1700.00

KENNEDY Plastic Jerry Cans

Secure water containers manufactured from food grade plastic available in 10, 15 and 20ltr capacities, fitted with a collared screw top for ease of refilling and a twist on-off tap for spill free dispensing. The moulded handle design makes it ideal for transporting and storing water in and around the work place, home or when travelling.



Capacity	Type	Order Code	Price/1 TB
10ltr	Water	-6500K	698.00
15ltr	Water	-6520K	949.00
20ltr	Water	-6540K	1075.00

2kW Flat Fan Heater

Two heat settings - 1000W and 2000W. Variable heat thermostat with frost protection. Cooling fan setting. Safety overheat cut-out. Power Indicator light.



1 COOL SETTING

Max Output	Weight (each)	Order Code	Price/1 TB
2000W	1.26kg	-0120K	979.00

Halogen Heater

The Kobe Halogen Heater comes with three heat settings: 400W, 800W and 1200W. It has an oscillating function and comes with two built in safety features: tilt trip switch and an overheat cutout. An ideal portable heater with an integrated handle making it easy to carry.

Power consumption: 400/800/1200W. **Voltage:** 220-240V AC. **Frequency:** 50Hz.



3 HEAT SETTINGS

Max Output	Order Code	Price/1 TB
1200W	-0140K	1327.00

Electric Heater

The Kobe Convector Fan/Heater comes with three heat settings: 750W, 1250W and 2000W as well as a built in circulation fan which can be used for both hot and cold air functions. It comes with a 24 hour timer, a variable thermostat with frost protection and a safety overheat cutout. The heater is free standing or wall mountable and comes with built in carry handles on either end of the heater.

Power consumption: 750/1250/2000W **Voltage:** 220-240V AC. **Frequency:** 50Hz.



Thermostat control and programmable timer

Max Output	Order Code	Price/1 TB
2000W	-0130K	2282.00

GROUP 836 NOTICE BOARDS

Offis A1 Freestanding 'A' Frame

Suitable for indoor/outdoor. Ideal for promoting products or displaying awareness information. Can be used in multiples to promote a series of information to people on the move. Double sided to display alternate traffic directions simultaneously.

Anti-glare PVC poster cover helps to protect against environment and help maintain maximum visibility.



Description	Order Code OFI-836	Price/1 TB
A1 Freestanding 'A' Frame	-0190K	9628.00

Cork Notice Boards - Aluminium/ Wooden Frames

Cork boards are preferable for displaying notices and communications and they free your working area of knick-knacks. The boards will last for years even with daily use. Available in a choice of three sizes with anodised aluminium or wood frame finish.



Size	Order Code OFI-836	Price/1 TB
Aluminium Trim		
600 x 450mm	-0160K	903.00
900 x 600mm	-0170K	1009.00
Wooden Trim		
600 x 450mm	-0130K	339.00
900 x 600mm	-0140K	467.00
900 x 600mm	-0150K	1167.00

Felt Notice Boards - Aluminium Frames

Boards covered with felt in a range of colours for your business or personal use. Four fabric colours: blue, green, grey and red. In two sizes.

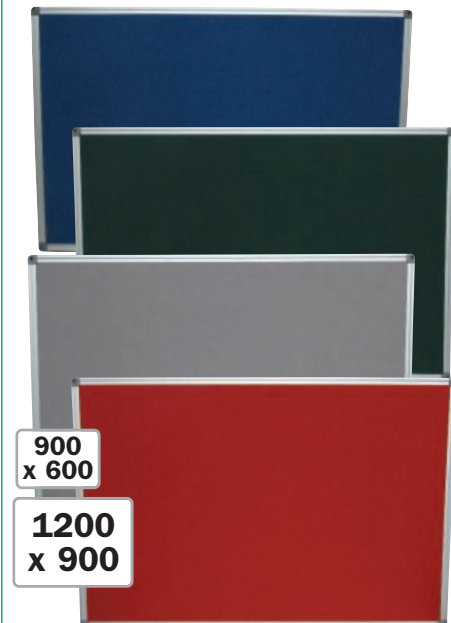

Colour	Size	Order Code OFI-836	Price/1 TB
Blue	900 x 600mm	-0050K	1034.00
Green	900 x 600mm	-0060K	1034.00
Red	900 x 600mm	-0080K	1034.00
Blue	1200 x 900mm	-0090K	2019.00
Green	1200 x 900mm	-0100K	2019.00
Grey	1200 x 900mm	-0110K	2019.00
Red	1200 x 900mm	-0120K	2019.00

SOLENT OFFICE Whiteboard Cleaner & Wipes

Whiteboard Cleaner

Cleans like new! Effectively cleans dry wipe marker pen from most whiteboards. Non-toxic, non-hazardous fluid. Leaves whiteboards looking new. 250ml spray bottle. Use with Solent Dry Wipe Cloths (SOL-780-6840E) available separately.

Whiteboard Wipes

Pre-moistened whiteboard wipes effectively cleans dry wipe marker pen from most whiteboards. Non-toxic. Non-hazardous. Leaves whiteboards looking like new.

Tub contents: 100.



Description	Order Code SOL-780	Price/1 TB
Cleaner	-7000A	140.00
Wipes - Tub 100	-7020C	170.00

Freestanding Snap Frame

Lightweight frames for indoor or outdoor use. Attractive 'cushion profile' frames made from smooth satin finish Aluminium. A clear flexible plastic front sheet protects the contents from dust and contact. Height adjustable tubular steel stand features a ratchet slider mechanism to allow rapid adjustment. Mirror chrome finish. Ideal for use in lobbies, receptions or as a temporary traffic direction sign.



Ratchet slide adjustment



Frame Size	Height Range (mm)	Base Dia.	Weight (each)	Order Code OFI-836	Price/1 TB
A4	1050-1450	245	2.5kg	-0460K	1592.00

Executive Felt Covered Notice Boards - Aluminium Frames

Aluminium framed, executive felt covered notice boards. Available in blue, green, and grey with a satin finish aluminium frame.

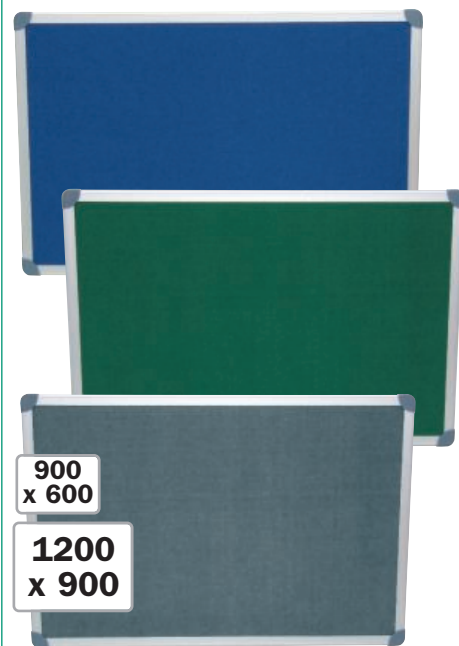

Colour	Size	Order Code OFI-836	Price/1 TB
Blue	900 x 600mm	-0280K	2276.00
Green	900 x 600mm	-0290K	2276.00
Grey	900 x 600mm	-0300K	2276.00
Blue	1200 x 900mm	-0310K	3793.00
Green	1200 x 900mm	-0320K	3793.00
Grey	1200 x 900mm	-0330K	3793.00

OFFICE SUPPLIES & PACKAGING



Drywipe Boards

These whiteboards have a revolutionary new surface which is ultra smooth to improve erase ability and reduce ghosting. Plain white surface, supplied with wall fixings and pen tray.

Ultra Smooth Single Sided Magnetic Whiteboards

Surface guaranteed for five years in normal use. Surface can be used with any whiteboard markers and easy to wipe off.

Ultra Smooth Non-magnetic Whiteboard

Laminated dry-wipe whiteboard surface. Use with any whiteboard markers and easily wiped off by eraser.

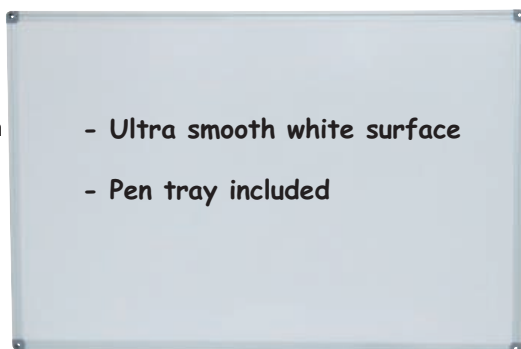

Type	Size	Order Code OFI-836	Price/1 TB
Standard	900 x 600mm	-0030K	1109.00
	1200 x 900mm	-0040K	2159.00
Magnetic	900 x 600mm	-0010K	1926.00
	1200 x 900mm	-0020K	2575.00

Executive Dry Wipe Boards

The Offis™ Executive dry wipe white board is ideal to use in training seminars, presentations, in the classroom or anywhere else ideas or procedures need communicating to several people at the same time. The extra smooth bright white surface improves erasability, reduces ghosting and provides a good contrast to anything written or drawn on it. Finished with an attractive aluminium trim and ABS plastic corners that will complement any conference or meeting room, supplied with concealed wall fixings and pen tray.

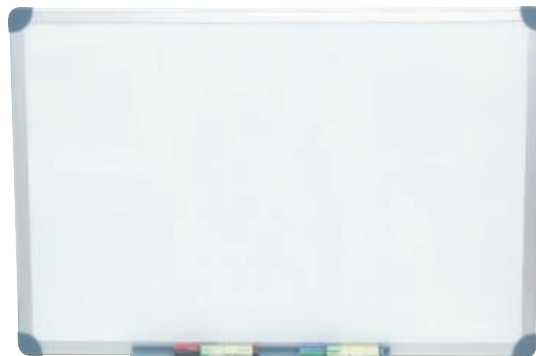

Type	Size	Order Code OFI-836	Price/1 TB
Magnetic	900 x 600mm	-0240K	2746.00
	1200 x 900mm	-0250K	4407.00
Non-magnetic	600 x 300mm	-0340K	903.00
	900 x 600mm	-0260K	2918.00
	1200 x 900mm	-0270K	3735.00

Mobile Magnetic Drywipe Boards

Stylish and modern aluminium-framed mobile whiteboard to complement all conference and meeting rooms. Magnetic surface. Whiteboard is suspended on a horizontal pivot and mobility is provided by four leg castors. Complete with pen tray.

Available in two sizes:
1200 x 900mm and 500 x 1200mm.



Size (mm)	Order Code OFI-836	Price/1 TB
1200 x 900	-0360K	6313.00
1500 x 1200	-0370K	8966.00

Magnetic Markers

Round flat top magnets for use on magnetic planning boards, white boards or easels. Supplied in packs of 10.



Diameter	Colour	Order Code OFI-836	Price/Pk TB
20mm	Assorted	-0500K	160.00
35mm	Assorted	-0510K	186.00

Folding Magnetic Drywipe Board

Silver trimmed folding whiteboard.

Dimensions:

1200 x 900mm with two folding end panels which double the display area. Panels can be closed; useful for concealing sensitive information, for example. Includes pen tray and wall fixings.



Size (mm)	Order Code OFI-836	Price/1 TB
1200 x 900	-0350K	5252.00

Adhesive Gridding Tape

Non-Magnetic vinyl tape, ideal for creating any form of grid, table or guide lines on drywipe and magnetic boards.

Length: 16.5m
Colour: black.



Description	Size (mm)	Order Code OFI-836	Price/1 TB
Gridding Tape	1.50 x 16.5	-0480K	266.00
	3.00 x 16.5	-0490K	346.00
Dispenser for Tape		-0520K	160.00

GROUP 837 PACKING ROLLS

AVON Blown Stretch Wrap

For wrapping and stabilising pallet loads. Protects from weather and dust whilst in transit or storage. Sticks only to itself and not the wrapped items. All case quantities are per six except 100mm x 150m which are per 48.

All rolls have extended cores.



All prices are per roll

Roll Size	Thickness (Micron)	Colour	Order Code AVN-837	Price/1 TB
100mm x 150m	17	Clear	-0520K	160.00
	20	Clear	-0530K	160.00
	22	Black	-0620K	205.00
400mm x 200m	34	Clear	-0680K	670.00
	15	Clear	-0540K	478.00
	17	Clear	-0550K	585.00
400mm x 300m	20	Clear	-0560K	691.00
	25	Black	-0570K	797.00
	17	Red	-0580K	585.00
	17	Blue	-0590K	585.00
500mm x 300m	20	Clear	-0670K	691.00
500mm x 200m	35	Clear	-0660K	773.00
400mm x 300m (Extended Core)	17	Clear	-0600K	567.00
	20	Clear	-0610K	670.00

High Yield Hand Stretch Wrap

Ideal for wrapping uniform shaped pallet loads where cost is a concern. The lower micron high yield stretch wrap will perform as well as higher micron blown stretch wrap on uniform low to medium weight pallet loads. Used to protect and stabilise pallet loads, prevents split deliveries and damage from weather and dust whilst in transit or storage. Sticks only to itself and not the wrapped items.



Roll Size (mm x m)	Thickness	Case Qty	Order Code AVN-837	Price/1 TB
400 x 300	12 Micron	6 rolls	-0700K	372.00

Stretch Wrap

Avon Q-Lite the innovative pre-stretched film makes wrapping pallets easier and more efficient. There is no need to stretch the film to get maximum load holding. Operators will appreciate the ease with which Q-Lite can be applied. Q-Lite allows you to reduce waste, as the characteristics of the film mean that lost and broken ends (edge hang-up) are virtually eliminated and the film can be used to the very end of the roll.



Roll Size	Thickness (Micron)	Order Code AVN-837	Price/1 TB
400mm x 600m	8	-1830K	514.00
450mm x 600m	8	-1840K	617.00

Stretch Wrap Dispensers

Adjustable Dispenser

Strong, lightweight aluminium base and core cover. Can be adjusted from 12" to 20" with a foam grip handle.

Capacities: stretch wrap width 12" to 20".

Core sizes: 1½", 2" and 3".



Adjustable

Standard Dispenser

For 400/500mm stretch wrap on 38/50/75mm core.

Weight: 1.45kg.



Mini Dispenser

Using coreless stretch wrap means no wastage saving money - up to 17.5% savings per reel compared to a mini reel with a core. Saves time when changing reels - no core to remove from dispenser.



Description	Order Code AVN-834	Price/1 TB
Standard Dispenser	-0130K	1396.00
Adjustable Dispenser	-0110K	1612.00
Mini Dispenser	-0070K	181.00

Machine Stretch Film

Cast film is extruded as a flat sheet, resulting in higher outputs than blown film extrusion. Cast film predominates in machine applications and generally has superior optical properties of clarity and gloss.

Standard Cast Film

Will stretch in excess of 140%. For use on standard wrapping machines.

Super Power Pre-Stretch Film

Will stretch in excess of 250% when used on a power pre-stretch machine.



Grade	Roll Size	Thickness (Micron)	Order Code AVN-837	Price/1 TB
Standard	500mm x 1350m	23	-1910K	3219.00
Super Power	500mm x 1550m	20	-1920K	3605.00

Waxed Kraft Paper Rolls

A water-resistant paper made by waxing on both sides, frequently used for the wrapping of engineering components.

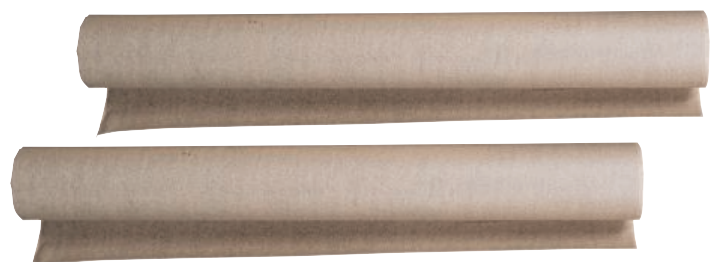

Size	Order Code AVN-830	Price/1 TB
900mm x 100m (55gsm)	-0260K	1115.00

AVON Polythene Bags (Plain)

Heavy duty food grade polythene bags to suit all of your packaging requirements.



Size (mm)	Size (inch)	Pack Quantity	Order Code AVN-837	Price/Pk TB
230 x 300	9" x 12"	250	-1315K	1167.00
400 x 500	15" x 20"	100	-1370K	1274.00
610 x 910	24" x 36"	100	-1400K	3316.00

Gripseal Polythene Bags - Plain

Plain gripseal bags. Medium duty. Pack of 1000.



PACK OF 1000

Size (mm)	Size (inch)	Order Code AVN-837	Price/Pk TB
38 x 40	1½" x 2½"	-1420K	186.00
223 x 280	8" x 11"	-1520K	1751.00
250 x 350	10" x 14"	-1540K	2653.00
400 x 500	15" x 20"	-1570K	6313.00

Gripseal Polythene Bags - Write On

Gripseal bags with three write-on stripes. Medium duty. Pack of 1000.



PACK OF 1000

Size (mm)	Size (inch)	Order Code AVN-837	Price/Pk TB
57 x 57	2¼" x 2¼"	-1580K	266.00
75 x 86	3" x 3¾"	-1590K	585.00
90 x 115	3½" x 4½"	-1610K	531.00
100 x 140	4" x 5½"	-1620K	691.00
127 x 190	5" x 7½"	-1630K	1009.00
150 x 230	6" x 9"	-1640K	1327.00
203 x 280	8" x 11"	-1650K	2388.00
255 x 355	10" x 14"	-1660K	3714.00

Woven Polypropylene Sacks

A material made by weaving polypropylene tapes in two directions to form a lightweight breathable fabric suitable for grains, seeds, minerals, sand and other products. Woven polypropylene bags offer the best packaging for a large variety of products in industries such as agriculture, chemical, mining, building materials, and construction. Woven polypropylene bags offer economy, better protection, weight savings, and greater strength than other available packaging.

PACK OF 100



Size (mm)	Size (inch)	Order Code AVN-918	Price/Pk TB
230 x 310	9" x 12"	-0020K	642.00
310 x 460	12" x 18"	-0030K	817.00
380 x 500	15" x 20"	-0040K	1109.00
460 x 620	18" x 24"	-0050K	1564.00
620 x 1000	24" x 40"	-0060K	2801.00

Sack Tying Tool

The tying tool to quickly and easily twist the tie around the neck of the sack to seal it.



Description	Order Code AVN-835	Price/1 TB
Sack Tying Tool	-0790K	1327.00

Sack Ties

PVC coated stainless steel sack ties, for use on polypropylene woven sacks and polythene sacks. Made from 1.2mm thick wire. Each tie is looped at each end. Sold in bundles of 1000 ties. These are easily applied with a sack tying tool sold separately.

PACK OF 1000

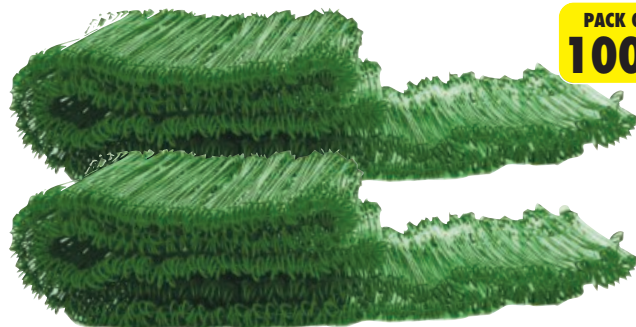

Size	Order Code AVN-835	Price/Pk TB
150mm (6")	-0800K	1009.00
200mm (8")	-0810K	1167.00
230mm (9")	-0820K	1327.00

PRODUCTS ARE ONLY AVAILABLE VIA YOUR DISTRIBUTOR

AVON Steel Hand Banding Ribbon

Ribbon: Each layer is wound directly over the one below, so that the width of coil is the width of strap. 0.5mm thickness.

Approximate breaking strain:

- 12mm:** 561kg,
- 16mm:** 714kg,
- 19mm:** 846kg.

Approximate reel length:

- 12mm:** 330m,
- 16mm:** 334m,
- 19mm:** 335m.

Mill Wound: Each layer oscillates across the layer below, uniformly and tightly across the 63.5mm width of the coil. 0.5mm thickness.

Approximate breaking strain:

- 12mm:** 561kg,
- 16mm:** 714kg,
- 19mm:** 846kg.

Approximate reel length:

- 12mm:** 965m,
- 16mm:** 763m,
- 19mm:** 643m.



Prices for steel banding may change subject to manufacturer's surcharges.

Steel

Ribbon Wound		
Width x Length	Order Code AVN-837	Price/1 TB
12mm x 330m	-1730K	2228.00
16mm x 334m	-1740K	2547.00
19mm x 335m	-1750K	3131.00

Mill Wound		
Width x Length	Order Code AVN-837	Price/1 TB
12mm x 965m	-1760K	6896.00
16mm x 763m	-1770K	7162.00
19mm x 643m	-1780K	6790.00

Steel Sealer

Suitable for use with 13mm, 16mm or 19mm seals. Use in conjunction with Tensioner (AVN-835-0880K).

Capacity: 19mm.



Capacities	Order Code AVN-835	Price/1 TB
13, 16 & 19mm	-0890K	1640.00

Seals

Zinc finish.

Snap On:

Placed over the overlapping strap ends.

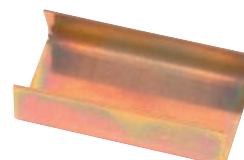

Lap Over:

Must be threaded onto strap before tensioning.



Type	Pk Qty	Size (mm)	Order Code AVN-835	Price/1 TB
Snap on	1000	12	-0710K	1433.00
	1000	16	-0720K	1327.00
	1000	19	-0730K	1539.00
Lap over	4000	12	-0740K	6896.00
	2500	16	-0750K	6313.00
	2000	19	-0760K	7162.00

AVON Polypropylene Banding

Polypropylene plastic banding supplied on reels suitable for hand banding. Black, packed individually.

Width: 12mm.

Approximate breaking strain:

- R13:** 130kg,
- R21:** 210kg, **R30:** 300kg.

Polypropylene



Type	Length (m)	Order Code AVN-837	Price/1 TB
R13	2000	-1800K	1853.00
R21	1300	-1810K	1956.00
R30	1000	-1820K	2059.00

Machine Quality Polypropylene Banding

Suitable for use on automatic strapping machines. Supplied on 200/190mm cardboard cores 0.55mm thick.

Colour: blue.

Breaking strain: 130kg*.

Polypropylene

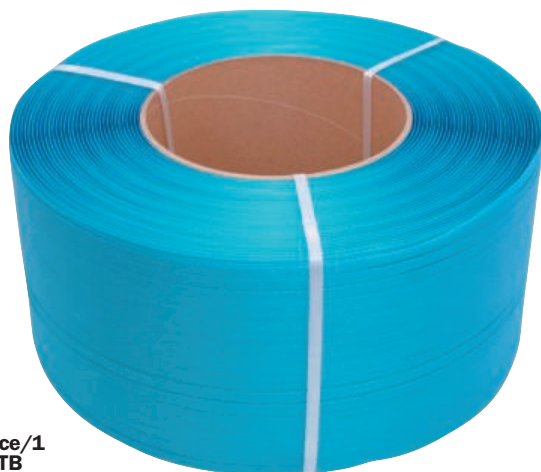

*All breaking strains are approximate.

Width x Length	Order Code AVN-837	Price/1 TB
12mm x 3000m	-1790K	2653.00

Strapping Tensioner - Polypropylene

Robustly built non-slip ratchet tensioner with cutter for polypropylene strapping. Can be used horizontally to palletise goods. For use along side crimpers.

Capacity: 12 - 15mm



Capacity	Order Code AVN-835	Price/1 TB
12 - 15mm	-0880K	2323.00

Polypropylene Banding Seals

For securing polypropylene banding around objects.

Width: 12mm.

Polypropylene

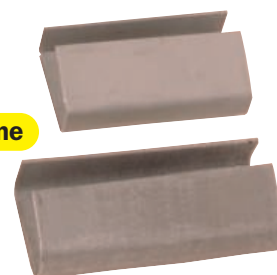

Priced per pack

Type	Pk Qty	Order Code AVN-835	Price/1 TB
Plain			
Standard	2000	-0690K	1009.00
Heavy	2000	-0700K	1539.00
Serrated			
12mm	1000	-0770K	1858.00
16mm	1000	-0780K	2653.00

AVON Polyester Strapping

A low creep factor enables excellent retention of applied load, while ease of application and disposal enables fast efficient packaging by manual or automatic process.

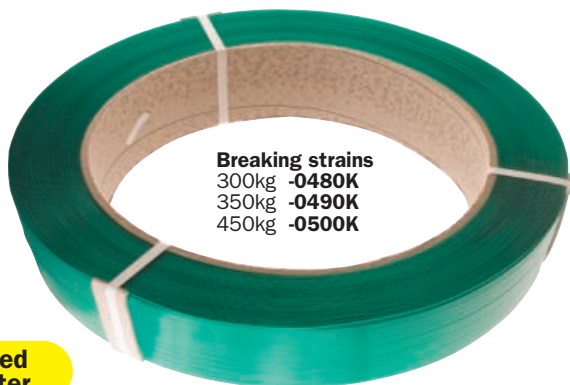

Extruded Polyester

Width x Length	Order Code AVN-837	Price/1 TB
12.0 x 0.60mm x 2500m	-0480K	5995.00
12.0 x 0.68mm x 2200m	-0490K	6101.00
15.5 x 0.68mm x 1750m	-0500K	6207.00

Woven Polyester Strapping

Woven polyester strapping with almost the strength of steel banding and unaffected by extremes of temperature. Can be re-used when secured with metal buckles.

Core size: 78mm.

Woven Polyester



Width x Length	Breaking Strain	Order Code AVN-837	Price/1 TB
13mm x 1100m	375kg	-1860K	6366.00
16mm x 850m	450kg	-1870K	6896.00
19mm x 600m	550kg	-1880K	5252.00

Polypropylene Strap & Seal Kit

Portable polypropylene strap and seal kit for general duty strapping and bundling tasks. Pull out and cut the polypropylene strapping to the required length, place a seal over the overlapping strap ends and close with a strapping sealer or combination tool. Perfect for solving smaller packaging, bundling and stability problems.

Kit contains: 1x coil of polypropylene strapping, size 12mm x 800m in a cardboard dispenser box. 300 semi-open metal seals.



Polypropylene

Size (Width x Length)	Order Code AVN-835	Price/1 TB
12mm x 800m	-0870K	2070.00

Strapping Buckles

Galvanised buckles for use with polypropylene and composite strapping. Available in three different thicknesses.

Box quantity: 1000 buckles.



Buckle Size	Wire Thickness	Order Code AVN-835	Price/1 TB
13mm	3.3mm Ø	-0840K	3343.00
16mm	3.5mm Ø	-0850K	3608.00
19mm	3.8mm Ø	-0860K	4510.00

Static Strapping Dispenser

Static strapping dispenser for use with woven cord polyester strapping. Rear mounted plastic box ensures seals and tools are always at hand.



Woven Polyester

Description	Order Code AVN-835	Price/1 TB
Static Dispenser	-0830K	3608.00

Expandable Corner Edge Protectors

Solid plastic closed corner protectors are a cost effective way of protecting vulnerable corners during transit. Ideal for use on tables, desks, doors, signs, mirrors, furniture etc.

Medium size: 16 - 40mm.
Large size: 35 - 70mm.



Size	Pack Qty	Order Code AVN-835	Price/1 TB
Medium	1000	-0910K	5212.00
Large	250	-0920K	12875.00

Edge Protectors

Plastic pallet load edge protectors help stop the straps from getting cut whilst also protecting the products on the pallet from the strap tension.



Size	Pk Qty.	Order Code AVN-830	Price/Pk TB
Small	1000	-0290K	876.00
Medium	1000	-0300K	1391.00
Large	1000	-0310K	3039.00

Closed Corner Edge Protectors

Solid plastic closed corner protectors are a cost effective way of protecting vulnerable corners during transit. Ideal for use on tables, desks, doors, signs, mirrors or furniture etc.

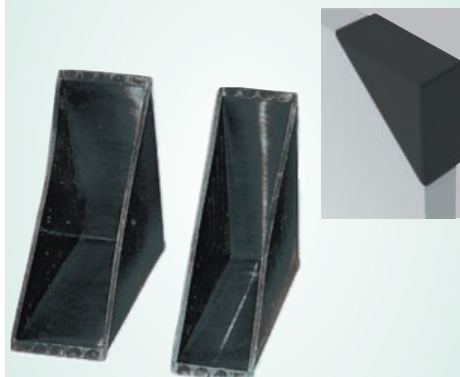

Size (mm)	Pack Qty	Order Code AVN-830	Price/1 TB
60 x 60 x 15	1000	-2250K	3767.00
60 x 60 x 18	1000	-2260K	3926.00
60 x 60 x 22	850	-2270K	3501.00
60 x 60 x 28	700	-2280K	3501.00

AVON Telescopic Squared Tube Packaging

Telescopic-style plastic packaging with ratchet mechanism to accommodate tools of varying lengths and sizes. Strong, durable and resistant to oil and moisture. Available in a range of sizes (16mm-55mm) and two adjustable lengths (80-120mm and 120mm-200mm).

Pack of 50.
Colour: red.

NEW



Pack Qty	Size (W x H)	Length (mm)	Order Code AVN-837	Price/Pk TB
50	16 x 16	80 - 120	-2010K	1029.00
	20 x 20	80 - 120	-2020K	1082.00
	26 x 26	80 - 120	-2030K	1133.00
	20 x 20	120 - 200	-2040K	1339.00
	24 x 24	120 - 200	-2050K	1391.00
	26 x 26	120 - 200	-2060K	1442.00
	32 x 32	120 - 200	-2070K	2472.00
	35 x 35	120 - 200	-2080K	2575.00
	45 x 45	120 - 200	-2090K	2987.00
	55 x 55	120 - 200	-2100K	3348.00

Heavy Duty Staple Remover

Toughened steel head and support to remove almost all staples. Large ergonomic plastic handle for comfort grip. Wide footprint provides good leverage and reduces risk of surface damage.



NEW

Model Number	Order Code AVN-838	Price/1 TB
ST001	-0050K	335.00

Packaging with Detachable Units

Versatile packaging combining single unit with multiple packaging. Detachable units avoid time consuming packing of single items. Any number of single units possible - simply detach as required. Made from polypropylene these are strong, durable and resistant to oil and moisture.

Available in five piece packs of 50.
Colour: red.



NEW

Size (W x L) mm	Pack Quantity	Order Code AVN-837	Price/Pk TB
8 x 104	50	-2110K	2472.00
10 x 105	50	-2120K	2730.00
12 x 114	50	-2130K	3193.00

Heavy Duty Hammer Tacker

Suitable for a variety of applications including carpet fitting and roof felting. Manufactured from heavy duty steel with a chrome finish and comfortable rubber grip. For use with 140 staples.



NEW

No. 140
10mm

Model Number	Order Code AVN-838	Price/1 TB
R311	-0020K	1417.00

Heavy Duty Professional Metal Tacker

All Steel construction with lock function. Ideal for wood, carpet and plastic. Takes 6 - 14mm staples. Four year guarantee.



No. 140

6 - 14 (mm)

NEW

Staple Size	Order Code AVN-838	Price/1 TB
6 - 14mm	-0040K	1185.00

Heavy Duty Chrome Staple Gun

Manufactured from heavy duty steel with a chrome finish. Easy squeeze handle. Jam-proof mechanism. For use with 140 staples. Supplied with 400x 1.2 x 8mm staples.



No. 140

8mm

Supplied with **400** Staples

NEW

Staple Size	Order Code AVN-838	Price/1 TB
1.2 - 8mm	-0010K	773.00

Metal Handle Staple Gun

Multi purpose gun, plastic body and metal handle. Ideal for home and light duty repairs. Takes 4 - 8mm staples.



No. 53

4 - 8 (mm)

NEW

Staple Size	Order Code AVN-838	Price/1 TB
4 - 8mm	-0030K	361.00

Offis 4-in-1 Rotary Trimmer

A multi-functional rotary trimmer. Ideal for offices, homes and schools. Straight-cut, wave-cut, perforates and scores. Five sheet (80gsm) capacity. Safety cutting head with round stainless steel blade. Visual positioning aids. Finger cutting guard/transparent pressing rail. Non-slip rubber feet.

Max cut length: 300mm.

A4

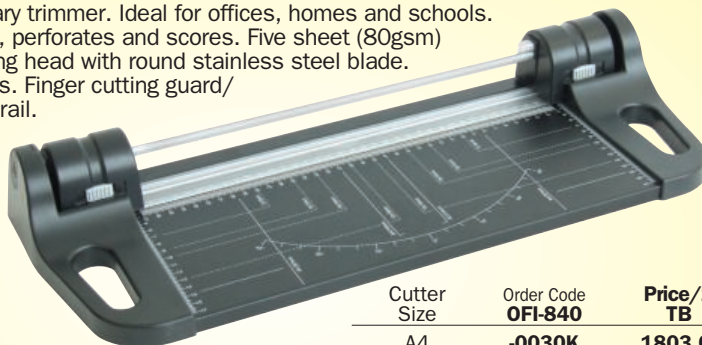

Cutter Size	Order Code OFI-840	Price/1 TB
A4	-0030K	1803.00



OXFORD PRECISION **Portable Bench Scales**

Suitable for office, postroom or stores applications, the scales are mains or battery powered (4x AAA batteries not included). Featuring a large, clear digital display, dual reading (metric or imperial), and self-levelling, anti-slip rubber feet.



Model Number	Maximum Capacity	Order Code	Price/1 TB
OPB60	60kg	-5340K	N/A
OPB120	120kg	-5380K	N/A

Suspended Weighing Scales

The Oxford range of weighing equipment provides you with a choice of capacity and accuracy to suit the majority of purposes. These sturdy scales have a dual-reading dial protected by a plastic cover. With a capacity of up to 25kg/55lb they are ideal for workshops, schools and offices and have a zero setting of $\pm 15\%$ with accuracy to one part in 250. It comes complete with top and bottom chrome vanadium hooks.



Model Number	Maximum Capacity	Order Code	Price/1 TB
55-25M	25kg	-3500K	1226.00

WEIGHING SCALES

Glass Top Digital Platform Scales

LCS03

Stylish and hygienic digital platform scales. ideal for accurate weighing of ingredients. Capacity of 5000g/11lb. Platform diameter of 160mm. Tare weight function. Overload indication. Low voltage alarm. Auto power off after 90 seconds.

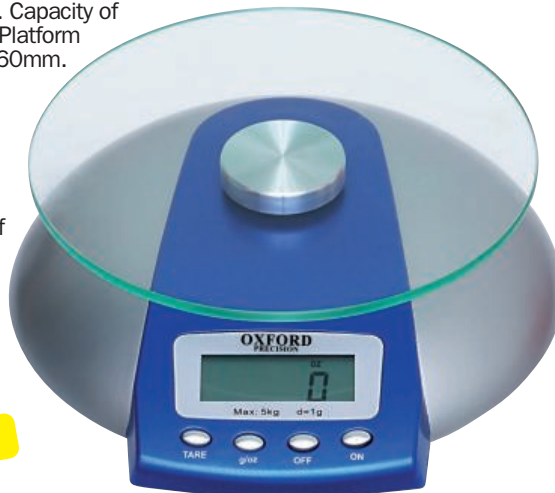

Capacity	Platform Size	Order Code	Price/1 TB
5000g/11lb	160mm	OXD-844 -2840K	N/A

Electronic Weigh & Count Scales

Suitable for office, postroom or stores applications, the scales are designed to run on mains power or rechargeable battery (included). The large digital display is easy to read and metric or imperial readings can be selected.



Maximum Capacity	Order Code	Price/1 TB
6kg	OXD-844 -2040K	N/A
15kg	-2070K	N/A

Electronic Weighing Scales

Suitable for office, post room and stores applications. Digital display. Designed to run on mains power via the 12Vdc 650mA AC adaptor provided or the 6V4AH rechargeable battery (included). Units will run up to 20 hours on a single full charge.

Model WS-6E:
Capacity: 6kg/12lb.
Graduation: 0.001kg/0.002lb.

Model WS-15E:
Capacity: 15kg/31lb.
Graduation: 0.002kg/0.005lb.



Model Number	Maximum Capacity	Order Code	Price/1 TB
WS-6E	6kg	-2200K	N/A
WS-15E	15kg	-2220K	N/A

GROUP 956 PROTECTIVE SLEEVING



Exceptional, effective and economical protection for all kinds of products.

- Ideal protection for machined components during production and storage.
- Also widely used to protect ceramics, glass and other fragile components/products through storage and distribution.
- Designed to help prevent both surface and impact damage.
- 'Cushion' products during transportation.
- 6 colour-coded sizes.
- High stretch capability handles products/components up to 400mm diameter.
- Exceptional formability and flexibility means irregular and intricate shapes can be protected.
- Supplied in purpose-designed dispenser cartons.



Colour	Diameter Range	Overall Length	Order Code AVN-956	Price/1 TB
Orange	6 - 17	250m Reel	-4260K	3995.00
Black	10 - 25	250m Reel	-4130K	5938.00
Violet	25 - 60	50m Reel	-5500K	1293.00
Red	50 - 100	50m Reel	-4060K	1819.00
Yellow	100 - 200	50m Reel	-4800K	3772.00
Royal Blue	200 - 400	50m Reel	-5000K	4996.00



Superior Protective Slewing

- Slewing is manufactured from inert and chemical-resistant polymers.
- Neat and easy to use at any stage of the manufacturing/distribution process.
- Can stay in place through to end use and can 'add value' at retail.
- Heavy gauge/small aperture.
- High level protection.
- 11 colour-coded sizes.
- Tried and tested over many years.



Colour	Diameter Range	Overall Length	Order Code AVN-956	Price/1 TB
Red	6 - 13	50m Hank	-0060K	1203.00
Black	13 - 26	50m Hank	-0130K	1914.00
Orange	26 - 40	25m Reel	-0260K	1586.00
Brown	40 - 50	25m Reel	-0400K	1821.00
White	50 - 65	25m Reel	-0500K	2203.00
Grey	65 - 80	25m Reel	-0650K	2793.00
Yellow	80 - 100	25m Reel	-0800K	2966.00
Blue	100 - 125	25m Reel	-1000K	3012.00
Green	125 - 160	25m Reel	-1250K	4435.00
Straw	160 - 190	25m Reel	-1600K	5766.00
Royal Blue	190 - 225	25m Reel	-1900K	6923.00

High Stretch

Colour	Diameter Range	Overall Length	Order Code AVN-956	Price/1 TB
Pink	20 - 45	50m Hank	-2200K	1888.00
Purple	40 - 80	50m Reels	-2400K	2303.00
Green	75 - 125	25m Reels	-2750K	1846.00

OFFICE SUPPLIES & PACKAGING

AVON Clamp-on Tape Dispenser

Clamps to benches or work tops, for use with 75mm core tapes. Holds 1x 50mm width or 2x 25mm width tapes.



Product Number	Order Code AVN-979	Price/1 TB
CBD50	-1150K	711.00

Bag Neck Sealer

Can be used to seal food bags, storage bags and can also be used with flat plastic tubing. Heavy duty metal with a corrosion-resistant paint finish. Has a metal base with foam anti-slip pads fitted and can also be fixed to table or desk by four screws for stability. 10mm neck opening for use with tape up to 12mm wide x 66m on 75mm cores.



Core Diameter	Order Code AVN-979	Price/1 TB
75mm	-0010K	803.00

Vinyl Bag Neck Sealing Tape

Rolls of adhesive vinyl tape. 9mm wide x 66m in length on 75mm diameter cores. Can be used in many applications, but are mainly sold to be used with the neck bag sealer.

Pack quantity: 6 rolls.

PACK OF 6



All prices are per pack

Colour	Order Code AVN-981	Price/Pk TB
Blue	-2000K	514.00
Red	-2010K	514.00

Tape Dispensers

Sturdy construction with non-reversing plate and fixed brake. For use with 76mm core tapes. Available in two widths and with or without tension adjustment.

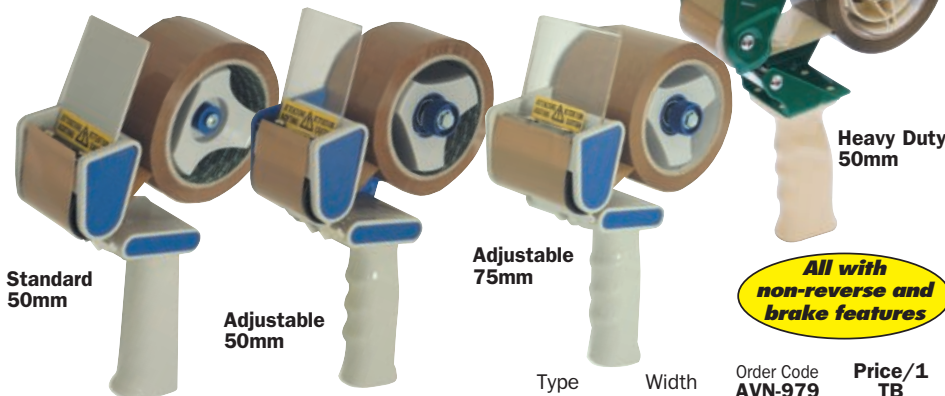

Type	Width	Order Code AVN-979	Price/1 TB
Standard	50mm	-2400K	235.00
Adjustable	50mm	-2420K	263.00
Spare Blade		-3010K	61.00
Spare Wiper		-3020K	61.00

Type	Width	Order Code AVN-979	Price/1 TB
Heavy Duty	50mm	-2360K	617.00
Spare Wiper		-3030K	47.00

Type	Width	Order Code AVN-979	Price/1 TB
Adjustable	75mm	-2440K	376.00

All with non-reverse and brake features

Desk Top Tape Dispensers

For use with standard 76mm core tapes up to 25mm wide.



Colour	Weight each	Order Code AVN-979	Price/1 TB
Red	1.357kg	-2160K	248.00
Blue		-2100K	248.00

Cellulose Tape

Clear, high grade conventional sticky tape. 76mm core.



Width x Length	Order Code AVN-981	Price/1 TB
12mm x 66m	-6380K	102.00
19mm x 66m	-6390K	155.00
24mm x 66m	-6400K	160.00
50mm x 66m	-6420K	361.00

KENNEDY Bench Top Dispenser

For use with 33mm core tapes up to 19mm wide. Weighted for fast one-hand use.

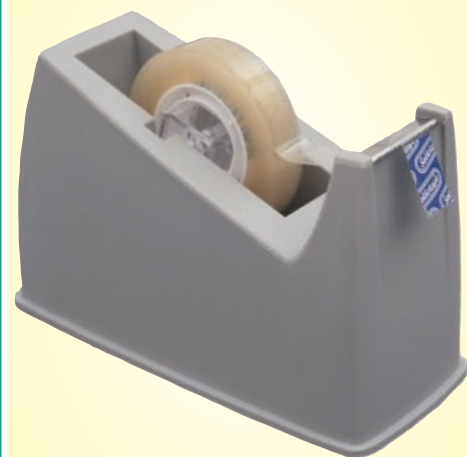

Type	Weight each	Order Code KEN-979	Price/1 TB
Bench Top	682g	-1080K	253.00

Filament Tape

Clear polypropylene film, reinforced with glass fibre filaments which are cross-woven into an aggressive high shear adhesive. Gives high strength across the width as well as along its length. Used for heavy reinforcement, and high security carton sealing. Adheres to all paper, card and plastics.

Extremely high strength cross woven filaments run the length and width of the tape.

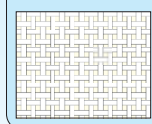

Width x Length	Pack Quantity	Order Code AVN-981	Price/1 TB
19mm x 50m	64	-0060K	181.00
25mm x 10m		-0180K	67.00
25mm x 50m	48	-0010K	247.00
38mm x 50m	24	-0020K	368.00
50mm x 10m		-0190K	129.00
50mm x 50m	18	-0030K	466.00
75mm x 50m	18	-0040K	669.00
100mm x 50m	18	-0050K	897.00

Selecting the right tape

Type of Tape	Description	Best For/Most Suitable Application	Adhesive Types
Vinyl (PVC)	Matt finish. Quiet coming off the roll. Slow release. Does not stretch. Can be torn by hand.	Long term storage. Easy to apply with dispenser. Best used at 18-21°.	Solvent - best long term adhesive.
Polypropylene	Shiny finish. Difficult to tear, requires dispenser or knife to cut. Noisy coming off the roll. Quick release. Does stretch.	Economical. High initial grab. Performs well in deep freeze conditions.	Solvent - best long term adhesive. Hot melt - solvent free adhesive. Acrylic - water based adhesive (environmentally friendly).
Low Noise Polypropylene	Shiny finish. Slow release. Can be torn by hand.	Combines to strength of polypropylene with the noiseless aspect of vinyl.	Solvent - best long term adhesive. Acrylic - water based adhesive (environmentally friendly).



Polypropylene Carton Tape

Standard tape - competitively priced, widely used in all sorts of packing applications. With rapid release from the roll, best applied with a dispenser fitted with a brake.



EXTENDED RANGE

25 Micron

Colour	Order Code AVN-981	Price/1 TB
Roll Size: 50mm x 66m		
Buff	-1060K	78.00
Clear	-1070K	78.00
Roll Size: 72mm x 66m		
Buff	-5340K	88.00
Clear	-5350K	88.00

High Grade Vinyl Sealing Tape

An economic way to seal your cartons. Available in 35 and 65-micron for strength and toughness, the waterproof low-static vinyl film is impact resistant and has excellent adhesive strength.

Standard: 35 micron.
Heavy duty: 65 micron.
76mm core.
Roll size: 50mm x 66m.



35 Micron or 65 Micron

Type	Order Code AVN-981	Price/1 TB
Standard	-2060K	160.00
Heavy Duty	-2260K	205.00

High Grade Vinyl Carton Tape

35 micron film thickness, silent and slow release. Can be torn using your fingertips, avoiding the need for a dispenser. 76mm core.

Roll size: 50mm x 66m.



35 Micron

Colour	Order Code AVN-981	Price/1 TB
Clear	-2070K	160.00

Printed Message Tapes

Printed vinyl tapes with low noise action and easy to read messages. Pre-printed with handling instruction and quality control information to warn carriers and ensure that your parcels and cartons are delicately handled, helping fragile goods or liquids to arrive safely. Clearly printed red on a white background. Can be used with pistol grip or bench dispensers.

Size: 50mm x 66m.



Message	Order Code AVN-981	Message	Order Code AVN-981
Fragile	-6200K	QC Inspected	-6270K
Handle with Care	-6210K	QC Rejected	-6280K
Caution	-6220K	QC Accepted	-6290K
'Glass' (Handle with Care)	-6230K	Quarantine	-6300K
Scrap	-6240K	Awaiting Inspection	-6310K
Passed	-6250K	Caution Liquids	-6320K
This Way Up	-6260K	Reject	-6330K
		Caution	
		Heavy Package	-6340K

Price/1 TB

Price per roll

160.00

Coloured Polypropylene Tape

Standard tape - competitively priced, widely used in all sorts of packing applications. With rapid release from the roll, best applied with a dispenser fitted with a brake.

Size: 50mm x 66m.



Colour	Order Code AVN-981	Price/1 TB
White	-1080K	106.00
Red	-1090K	106.00
Blue	-1100K	106.00
Green	-1110K	106.00
Yellow	-1120K	106.00

'Low Noise' Polypropylene Packing Tape

Slow and almost silent release characteristics. Difficult to tear using just fingertips.

For best results use in a dispenser fitted with a brake.
Roll sizes:
48mm x 66m. 28 microns.
75mm x 66m. 35 microns.

EXTENDED RANGE



28 Micron or 35 Micron

Colour	Order Code AVN-981	Price/1 TB
Roll Size 48mm x 66m		
Buff	-5000K	117.00
Roll Size 75mm x 66m		
Buff	-5040K	150.00
Clear	-5050K	150.00



Waterproof Cloth (Duct) Tape

Seals from air and completely waterproof - unaffected by humidity. Made from a lamination of polythene film cotton cloth and extremely strong rubber resin adhesive. Highly flexible and can be torn easily by hand. Can be cleanly removed when used for temporary repairs.

For applications where long term protection is required use 'Silver LT' tape.



EXTENDED RANGE

Colour	Order Code AVN-981	Price/1 TB
Roll size 50mm x 10m		
Silver	-3010K	102.00
Black	-3250K	102.00
Roll size 50mm x 50m		
Silver	-3060K	356.00
Silver LT	-0810K	617.00
Black	-3260K	356.00
Roll size 75mm x 50m		
Silver	-3070K	462.00
Black	-3280K	462.00

Coloured Waterproof Cloth (Duct) Tape

Seals from air and completely waterproof - unaffected by humidity. Made from a lamination of polythene film cotton cloth and extremely strong rubber resin adhesive. Highly flexible and can be torn easily by hand. Can be cleanly removed when used for temporary repairs.

Roll size: 50mm x 50m.



Colour	Order Code AVN-981	Price/1 TB
Blue	-3100K	389.00
Green	-3120K	389.00
Red	-3140K	389.00
White	-3160K	389.00
Yellow	-3180K	389.00

Triple Strength Cloth Tape

Avon triple strength duct tape has a unique super aggressive adhesive bonding system that bonds to everything. Its unique polythene backing is tough and durable and 100% waterproof. Tape will not twist and curl like inferior tapes commonly found in today's market. Manufactured using the latest technology the tape will perform in extreme weather conditions and will never let you down!



Colour	Width x Length	Order Code AVN-981	Price/1 TB
Silver	50mm x 33m	-5140D	361.00
	75mm x 33m	-5170D	567.00

Pipe Repair Tape

Used for waterproofing connections. The top protective layer is peeled off and the rubbery self-amalgamating tape underneath is wrapped tightly around the connection to be waterproofed. Eventually, the layers of this tape will merge together and create a permanent waterproof seal. Can be used for fast, temporary repairs to hoses and water pipes. Completely water and UV-resistant. Used to joint and repair a wide range of power and distribution cables up to 46kV. For above and below ground.

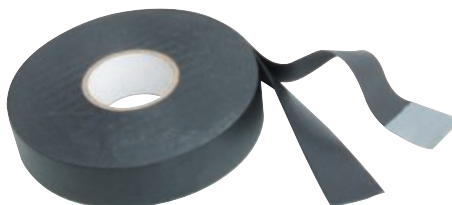

Colour	Width x Length	Order Code AVN-981	Price/1 TB
Black	25mm x 10m	-0940K	361.00

S.O.S. Repair Tape

Self fusing tape creates an air and water tight seal. Resists fuels, oils, acids, solvents, salt water, road salt and UV rays. Seals leaky hoses, pipes, and fittings.



Colour	Width x Length	Order Code AVN-981	Price/1 TB
Black	25mm x 3m	-4010K	411.00
Clear		-4020K	411.00
White		-4030K	411.00
Black	50mm x 3m	-4060K	938.00

Anti-Corrosion Tape



Grease impregnated petrolatum tape. Self-adhesive and waterproof. British Gas approved. Requires minimal preparation. Flexible. Protects water and gas pipes, cables, mechanical joints, valves, metal surfaces and tensioning bars against corrosion. Effective for long term sealing and protection. Works above and below ground and under water.

Conforms to **British Gas Standard BG/PS/CW2.**



Width x Length	Order Code AVN-981	Price/1 TB
50mm x 10m	-7100K	320.00
75mm x 10m	-7110K	420.00
100mm x 10m	-7120K	567.00
150mm x 10m	-7130K	926.00

Aluminium Foil Tape

4123

30 micron aluminium foil tape with liner and a high tack hot melt rubber adhesive. Conforms to **BS 476 Part 6 Class 0** and **Part 7 Category 1.** For joining foil-faced insulation panels and metal ducting.

Service temperature: -30°C to 85°C.



Width x Length	Order Code AVN-981	Price/1 TB
50mm x 45m	-0070K	320.00
75mm x 45m	-0080K	470.00

PVC Builder's Tape

Strong PVC builder's tape with versatile adhesive, ideal for jointing all PVC and polythene sheets and membranes, protecting door and window frames during plastering and painting and can also be useful for sealing bags and pallet wrappings for protection from the weather.



Colour	Width x Length	Order Code AVN-981	Price/1 TB
Black	50mm x 33m	-0090K	320.00
White		-0100K	320.00
Black	75mm x 33m	-0110K	438.00
White		-0120K	438.00

GROUP 981 BONDING TAPES

AVON Plasterboard Tape

Self-adhesive plasterboard fibreglass tape for fast application with a strong bond. Won't tear, stretch, shrink or bubble, and helps prevent cracks in plaster finishes.

Colour: White.
Size: 50m x 90m.



Width x Length	Order Code AVN-981	Price/1 TB
50mm x 90m	-0130K	365.00

All-Weather Outdoor Tape

Clear all-weather tape is ideal for use when splicing polythene sheeting, repair of greenhouses, trailer curtains, tents and marquees.



Width x Length	Order Code AVN-981	Price/1 TB
50mm x 20m	-0500K	245.00

14 Day Blue Masking Tape

A high quality blue creped paper masking tape with an acrylic adhesive. The special adhesive provides clean removability from a wide variety of surfaces for up to 14 days.



Width x Length	Order Code AVN-980	Price/1 TB
25mm x 10m	-0030K	53.00
25mm x 50m	-0010K	129.00
50mm x 10m	-0040K	88.00
50mm x 50m	-0020K	253.00

Masking Tape

Auto Grade
High grade. Easily removed. Suitable for spray or paint masking and temperatures up to 150°F/80°C.



Width x Length	Order Code AVN-980	Price/1 TB
12mm x 50m	-1020K	52.00
19mm x 50m	-1030K	72.00
25mm x 50m	-1040K	102.00
38mm x 50m	-1050K	140.00
50mm x 50m	-1060K	181.00
75mm x 50m	-1070K	258.00

General-Purpose
Suitable for walls and glass. Leaves no residue. For use in temperatures up to 105°F/60°C.



Width x Length	Order Code AVN-980	Price/1 TB
19mm x 50m	-2020K	78.00
25mm x 50m	-2030K	88.00
38mm x 50m	-2040K	129.00
50mm x 50m	-2050K	155.00
75mm x 50m	-2060K	222.00

Hi-Bond Acrylic Double-Sided Tape

High bond double-sided tape that bonds metals, plastics and glass. Strong enough to replace rivets, bolts, welds and other mechanical fixings. Vibration resistant and weatherproof. Used throughout the sign and transportation industry for bonding panels and re-enforcement struts.



Colour	Thickness x Width	Order Code AVN-981	Price/1 TB
Roll Length 10m			
Grey	0.8 x 12mm	-1710K	341.00
	0.8 x 19mm	-1720K	490.00
	0.8 x 25mm	-1730K	691.00
Clear	1.0 x 12mm	-1740K	448.00
	1.0 x 19mm	-1750K	691.00
	1.0 x 25mm	-1760K	903.00
White	1.1 x 12mm	-1770K	908.00
	1.1 x 19mm	-1780K	1014.00
	1.1 x 25mm	-1790K	1327.00
Roll Length 33m			
Grey	0.8 x 12mm	-1810K	1024.00
	0.8 x 19mm	-1820K	1659.00
Clear	1.0 x 12mm	-1840K	1341.00
	1.0 x 19mm	-1850K	2121.00
	1.0 x 25mm	-1860K	2575.00
White	1.1 x 12mm	-1870K	1447.00
	1.1 x 19mm	-1880K	2083.00
	1.1 x 25mm	-1890K	2295.00

Ultimate Double-Sided Bonding Tape

For permanent bonds. Fibre reinforcement for improved strength.



Size	Order Code AVN-981	Price/1 TB
25mm x 5m	-6110K	346.00
50mm x 5m	-6120K	490.00

SENATOR QUALITY TOOLING General Purpose Masking Tape

An everyday masking tape that can be used on most surfaces. Ideal for masking, bundling and labelling. Temperatures up to 60 degrees.

NEW



Width x Length	Order Code SEN-980	Price/1 TB
19mm x 50m	-0019D	47.00
25mm x 50m	-0025K	78.00
38mm x 50m	-0038M	88.00
50mm x 50m	-0050R	129.00
75mm x 50m	-0075V	181.00

INDUSTRIAL TAPES & CARTON KNIVES



Double-Sided Tape

Double-sided tissue tape with a high tack solvent acrylic adhesive. Hand tearable, good conformity, stable liner, excellent ultraviolet and plasticiser resistance. Ideal for bonding metal, nameplates, cloth and plastic surfaces.



Width x Length	Order Code AVN-981	Price/1 TB
25mm x 10m	-5900K	42.00
25mm x 33m	-6010K	186.00
25mm x 50m	-5910K	186.00
50mm x 10m	-6030K	98.00
50mm x 33m	-6020K	255.00

Low Tac Tape

Black

An outdoor polythene low-tack protection tape. Suitable for use on mild steels, stainless steels and aluminium. Ideal for short term protection of UPVC and aluminium profiles, window frames and metal ladders.

Thickness: 0.08mm.
Tensile strength: 17n/cm.
Elongation: 350%.
Steel adhesion: 2.2n/cm.

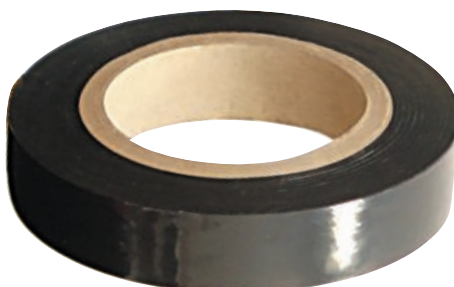

Width x Length	Order Code AVN-981	Price/1 TB
25mm x 100m	-0805K	232.00



Low Tac Red Tape

Low adhesive strength tape. Suitable for temporarily positioning labels, etc. Can be peeled off without damaging the contact surface.



Width x Length	Order Code KEN-981	Price/1 TB
25mm x 66m	-6200K	281.00

Cutting Safety Knife

High impact plastic handle with enclosed blade to ensure maximum user safety. Suitable for left and right handed users.



Overall Length	Order Code AVN-537	Price/1 TB
154mm	-0020K	160.00

Fish 2000 Safety Knife

The safety knife has an enclosed blade within a 4.7mm gap and an auto-retracting hook blade, to ensure maximum user safety and to reduce accidental damage to the product in the carton being opened. It is suitable for both left and right-handed users.



Overall Length	Weight each	Order Code AVN-537	Price/1 TB
155mm	50g	-0010K	318.00



Carton & Strap Cutter

For use on carton tape and plastic strapping. The blade is partially exposed to prevent accidental cuts.



Overall Length	Weight each	Order Code SEN-537	Price/1 TB
80mm	10g	-2000K	39.00

Carton Opener

For cutting through loading straps, extracting staples and slitting tape without damaging the contents. In-handle blade storage. Spring loaded blade guard, retractable slitting blade, complete with spare blade.

Overall length: 180mm.

NEW



Overall Length	Order Code AVN-537	Price/1 TB
180mm	-0030K	411.00

OFFICE SUPPLIES & PACKAGING

PRODUCTS ARE ONLY AVAILABLE VIA YOUR DISTRIBUTOR



GROUP 880 **ARC (MMA) & TIG WELDERS**



Page **702 - 704**

GROUP 880 **MIG/MAG WELDERS**



Page **706 - 707**

GROUP 885 **GAS WELDING & CUTTING**



Page **710**

GROUP 885 **WELDING ACCESSORIES**



Page **705 - 708**

GROUP 885 **HELMETS & PROTECTIVE CLOTHING**



Page **712 - 713**

GROUP 887 **MIG WIRE**



Page **709**

GROUP 889 **TIG TUNGSTEN ELECTRODES**



Page **704**

GROUP 891 **ARC WELDING ELECTRODES**



Page **703**



WELDING

Product Groups
860 - 891

Product Grading



Production

High performance industrial tooling designed for continuous use applications on machine tools where repeatability and long tool life are of critical importance.



Professional

Industrial tooling that has enhanced features and benefits demanded by craftsmen and professional users.



Industrial

Designed for regular use in industrial applications. Manufactured to stringent quality levels and international standards.



Workshop

Standard quality tooling for use by tradesmen and generally industrial use.



Maintenance

Products designed for general maintenance of machines, workshops, garages and some household applications.



Home Improver

DIY quality tooling. Designed for home use and light industrial applications.

Contents

Description	Group	Page
Arc (MMA) & TIG Welders	880	702 - 704
Arc Welding Electrodes	888	703
Clothing	885	713
Curtains	885	711
Fluids	885	711
Gas Welding & Cutting	885	710
Gloves	885	713
Helmets	885	712
MIG Welder Accessories & Spares	885	708
MIG Wire	887	709
MIG/MAG Welders	880	706 - 707
TIG Welder Accessories & Spares	885	705
TIG Tungsten Electrodes	889	704

GROUP 880 ARC (MMA) & TIG WELDERS

KENNEDY Lynx™ EAW-140 AC MMA Welder
QUALITY INDUSTRIAL TOOLING



A portable 230V single phase arc welder suitable for use with rutile electrodes of 1.6 - 3.2mm diameter. Capable of welding mild steel up to 6mm. Featuring a stepless regulator for infinite variable control of the welding current with low current facility for effective welding of thinner materials. Highly efficient transformer maximises potential. Safety features include thermal overload protection and turbo fan cooling - enables the ability to weld at greater power for longer periods. Provides full portability, ease of use and convenience and superb value. Operates from a 230V 13 amp standard domestic socket. Heavy duty casing. Two year warranty. Supplied complete with accessories, integrated carrying handle and 2m mains cable. Conforms to **TUV-GS, GOST, EMC, LVD** and all relevant **CE** requirements. Insulation class H. Protection degree IP21.

WELDING

TURBO FAN COOLED
2 YEAR WARRANTY
LOW CURRENT



Contents:

- Lynx™ AC power supply.
- 1.8m primary cable, 10mm².
- 1.8m earth cable and 150A clamp.
- Hand held face shield with 51 x 107mm glass.
- Scratch brush and slag remover.
- Instruction manual.

Input voltage: 230V, 50/60Hz.
Fuse rating: 13A.
Phase: 1.
Power consumption: 2.5kW.
Output current range: 40A - 140A.
Open circuit voltage: 50V.
Dimensions (L x W x H): 270 x 250 x 310mm.



Product Number	Current Range	Weight each	Order Code KEN-880	Price/1 TB
Lynx™ EAW140	40A - 140A	14.8kg	-2020K	9518.00

Cheetah™ EAW-160 AC MMA Welder

A portable 230V single phase arc welder suitable for use with rutile electrodes of 2 - 4mm diameter. Capable of welding mild steel up to 8mm. featuring a stepless regulator for infinite variable control of the welding current. Highly efficient transformer maximises potential. Safety features include thermal overload protection and turbo fan cooling - enables the ability to weld at greater power for longer periods. Provides full portability, ease of use and convenience and superb value. Operates from a 230V 13 amp standard domestic socket. Heavy duty casing, two large diameter solid wheels. 2 year warranty.

Supplied complete with accessories, two large diameter solid wheels, integrated carrying handle and 2m mains cable. Conforms to **TUV-GS, GOST, EMC, LVD** and all relevant **CE** requirements. Insulation class H. Protection degree IP21.

Contents:

- Cheetah™ AC power supply.
- 1.8m primary cable, 16mm².
- 1.8m earth cable and 250A clamp.
- Hand held face shield with 51 x 107mm glass.
- Scratch brush and slag remover.
- Instruction manual.

Input voltage: 230V, 50/60Hz.
Fuse rating: 16A.
Phase: 1.
Power consumption: 2.5kW.
Output current range: 55A - 160A.
Open circuit voltage: 50V.
Dimensions (L x W x H): 585 x 325 x 425mm.



TURBO FAN COOLED
2 YEAR WARRANTY



Product Number	Current Range	Weight each	Order Code KEN-880	Price/1 TB
Cheetah™ EAW160	55A - 160A	17.4kg	-2040K	10435.00

OSAKI Inverter Welder
POWER TOOLS

BEST SELLER

MMA Mini Max

Weighing in at less than 5kg, this has to be one of the lightest welders on the market. Its light weight does not mean it is less capable, it is in fact extremely portable and more versatile. It can be used with all types of electrodes, rutile, basic, stainless etc. The machine also benefits from the following technical features: hot start, arc force, anti-sticking, thermal cut-out.

Duty cycle @ 100%: 50A.
Duty cycle @ 60%: 65A.
Duty cycle @ 40%: 70A.
Voltage: open circuit (no welding being carried out) 70V.
Voltage supply: 230V.
Dimensions (W x D x H): 100 x 215 x 150mm.

NEW



WEIGHS LESS THAN 5kg

FOR DIY USE
 Not warranted for Industrial Use

Description	Weight each	Order Code OSA-279	Price/1 TB
Mini Max	1.8kg	-2000K	11500.00



KENNEDY *Electrodes for Mild Steels 6013*
QUALITY INDUSTRIAL TOOLING

Arc welding rods for mild steel and medium tensile steels. Medium rutile coated, all positional rods.

Applications: for steel plate and strip including structural steels and pipe work, especially under site conditions. Superb finish with self-releasing slag. **N.B.** Suitable for AC (50V minimum open circuit) and DC +/-.



FOR MILD STEEL & C-Mn STEEL

Recommended Amperages

Size (mm)	2.5	3.2	4.0
Min.	70A	95A	130A
Max.	100A	125A	170A

Size (mm)	No. of Rods (per pack)	Weight (per pack)	Order Code KEN-891	Price/Pk TB
2.50 x 300	260	5.0kg	-3010K	1541.00
3.25 x 350	150	5.0kg	-3020K	1541.00
4.00 x 350	100	5.0kg	-3030K	1693.00

Electrodes for Stainless Steels

316L

A Lime-Titania electrode giving excellent use ability and weldability, it deposits 19.5%Cr - 11.7%Ni - 2.5%Mo weld metal. The Austenite structure gives good crack resisting properties. For welding of extra-low carbon 18%Cr-12Ni-Mo stainless steel.

FOR STAINLESS



Recommended Amperages

Size (mm)	1.6	2.0	2.6	3.2	4.0
Min.	20A	25A	50A	80A	120A
Max.	40A	55A	90A	125A	180A

Type	Size (mm)	Number of Rods (Per Pk)	Weight (per Pk)	Order Code KEN-891	Price/Pk TB
316L	1.6 x 300	395	2.50kg	-1100K	4616.00
	2.0 x 300	200	2.50kg	-1110K	4456.00
	2.6 x 300	130	2.50kg	-1120K	3820.00
	3.2 x 350	70	2.50kg	-1130K	3714.00
	4.0 x 350	45	2.50kg	-1140K	3555.00

S312 Stainless/Dissimilar Electrodes

A Lime-Titania electrode giving excellent use ability and weldability, it deposits 29%Cr + 9%Ni weld metal. The Austenite nature resists cracking and provides a superb buffer effect against outer stress. For bond welding of dissimilar metals such as stainless steel, carbon steel, low alloy steel and welding of stainless clad steel.

FOR STAINLESS



*** Sizes available on request**

Recommended Amperages

Size (mm)	1.6*	2.0*	2.6	3.2	4.0
Min.			50A	80A	120A
Max.			90A	125A	180A

Size (mm)	Number of Rods (Per Pk)	Weight (Per Pk)	Order Code KEN-891	Price/Pk TB
2.60 x 300	260	2.50kg	-1030K	3714.00
3.20 x 350	150	2.50kg	-1040K	2918.00
4.00 x 350	100	2.50kg	-1050K	3449.00

Twist Grip Short Stub Electrode Holders

Reduce fatigue and increase safety. All of the electrode is available for use and the angle allows the hand to remain away from the weld pool. The handle applies torque to the electrode clamp in the head.



Rating (Amps)	Handle Colour	Order Code KEN-885	Price/1 TB
400	Yellow	-6010K	460.00
400	Red	-6110K	479.00
600	Red	-6130K	479.00

Electrodes for Mild Steels

E7018 ('Low Hydrogen')

Basic coated, all positional rods.

Applications: for steel plate structural steels, pipe work and forgings. Ideal for repairs of casting and machinery, compensate for dilution effect of poor steels. Often used where rutile deposits may be at risk from cracking. **N.B.** Suitable for AC (70V minimum open circuit) and DC+. Optimum rooting operability is obtained using DC-. Conforms with **AWS** and **BS EN** standards..



FOR MILD STEEL & C-Mn STEEL

Recommended Amperages

Size (mm)	2.6	3.2	4.0
Min.	70A	95A	130A
Max.	100A	125A	170A

Size (mm)	No. of Rods (per Pk)	Weight (per Pk)	Order Code KEN-891	Price/Pk TB
2.60 x 300	260	5.0kg	-5110K	1430.00
3.20 x 350	150	5.0kg	-5120K	1576.00
4.00 x 450	100	5.0kg	-5130K	1693.00

Electrodes For Cast Iron

S-NFC

A Graphite coated iron-nickel alloy electrode for high strength jointing of cast iron and cold welding of cast iron, it deposits 95%Ni + 2%Fe weld metal. Can be used for repairing broken cast iron, jointing of cast iron to steel and building up worn parts.

Meets the following standards:

AWS A 5.15 E Ni-C1
Din 8573 E Ni BG 11.



FOR CAST IRON



Type	Size (mm)	Recommended Amperage	Order Code KEN-891	Price/Pk TB
S-NFC	2.5	70A	-1220K	5517.00
	3.2	100A	-1230K	5359.00
	4.0	145A	-1240K	5040.00

GROUP 880 ARC (MMA) & TIG WELDERS

KENNEDY *Jaguar PFC Multi Voltage Inverter Welder*
QUALITY INDUSTRIAL TOOLING

Now you can have all the portability and performance of an inverter welder with a wide input voltage range of 100-240v. With the Jaguar PFC multi-voltage inverter welder you can carry out MMA welding with rutile, basic, stainless steel and cast iron electrodes, as well as TIG welding with scratch striking.

The fan cooled unit can handle unstable voltages and offers stable output in the case of over/under voltages. It also allows for the use of long extensions (over 100m) and has Hot Start for easy starting, Arc Force for quality welds and Anti-Stick for reduced electrode sticking. Comes with carry case and accessories.

Power Supply: 110/230V (DC) 50/60Hz single phase
Current Fuse Rating: 150A
Duty Cycle @40 degrees C: 90A@25%, 140A@25%
Protection class: IP22
Dimensions (L x W x H): 385 x 150 x 265mm.



NEW

WELDING

Description	Current	Voltage	Order Code KEN-880	Price/1 TB
Jaguar PFC	150A	230	-3120K	25750.00

Cougar-S™ MMA Inverter Welder

Kennedy® Cougar-S EWT150S inverter welder is ideal for use with rutile, basic, stainless steel or cast iron MMA electrode welding using 1.6 - 4.2mm diameter rods including Tig-DC scratch.

Features of the Cougar-S ETW150S:

- 230V single phase mains supply.
- Hot start - for easy starting.
- Arc force - for quality welds.
- Anti stick - reduces electrode sticking.
- Fan cooled.

Dimensions (H x W x D): 240 x 305 x 130mm.



Description	Current	Voltage	Weight each	Order Code KEN-880	Price/1 TB
Cougar-S MMA	150A	230	7.3kg	-3050K	19055.00



Tig Tungsten Electrodes

All conform to **ISO 6848 (DIN EN 26848 and AWS A5 12-92).**



0.8% Zirconiated White Tungsten Electrodes

Ideal for high precision, exceptional quality AC welding on aluminium alloys as it retains a balled tip and has a high resistance to contamination. The current carrying capability is equal or greater than that of thoriated tungsten. Non-radioactive. Not suitable for DC welding.

Electrode Type	Diameter	Order Code KEN-889	Price/1 TB
Zirconiated White	1.6mm	-0820K	88.00
	2.4mm	-0830K	129.00
	3.2mm	-0840K	232.00
	4.0mm	-0850K	450.00

2% Ceriated Grey Tungsten Electrodes

Suitable for both AC and DC welding but performs exceptionally well at low current settings in DC welding. A popular non-radioactive replacement for 2% Thoriated Tungsten Electrodes as like the thorium electrodes they are best used to weld carbon, stainless steels, nickel alloys, copper and titanium alloys. Also ideal for small and delicate welding.

Electrode Type	Diameter	Order Code KEN-889	Price/1 TB
Ceriated Grey	1.6mm	-0120K	70.00
	2.4mm	-0130K	129.00
	3.2mm	-0140K	266.00

2% Thoriated Red Tungsten Electrodes

Most commonly used tungsten electrode. Suitable for both AC and DC welding on carbon, stainless steels, nickel, copper and titanium alloys. Preferred for their longevity and ease of use.

Electrode Type	Diameter	Order Code KEN-889	Price/1 TB
Thoriated Red	1.0mm	-0510K	67.00
	1.6mm	-0520K	78.00
	2.4mm	-0530K	129.00
	3.2mm	-0540K	253.00

KENNEDY *Tig Torches & Bodies*
QUALITY INDUSTRIAL TOOLING

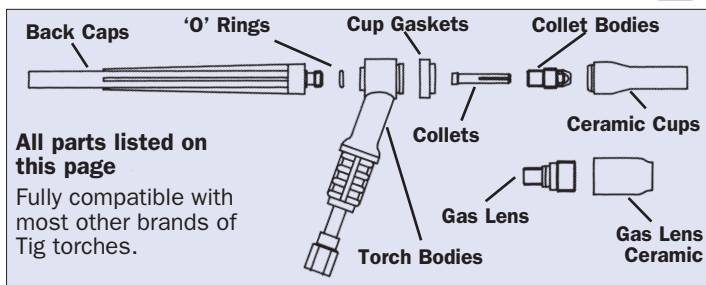

Collets

10N_ _ To suit WP17/18/26 torches.

Product Number	Bore Size	Order Code KEN-885	Price/1 TB
10N22	1.0mm (0.040")	-7210K	38.00
10N23	1.6mm (1/16")	-7220K	38.00
10N24	2.4mm (3/32")	-7230K	38.00
10N25	3.2mm (1/8")	-7240K	38.00

Collet Bodies

10N_ _ To suit WP17/18/26 torches.

Product Number	Bore Size	Order Code KEN-885	Price/1 TB
10N29	0.5mm (0.020")	-7290K	79.00
10N30	1.0mm (0.040")	-7260K	99.00
10N31	1.6mm (1/16")	-7270K	99.00
10N32	2.4mm (3/32")	-7280K	99.00
10N28	3.2mm (1/8")	-7250K	99.00

Ceramic Cups - Standard Length

10N_ _ To suit WP17/18/26 torches.

Product Number	Bore Size	Order Code KEN-885	Price/1 TB
10N50	1/4" (No. 4)	-7360K	75.00
10N49	5/16" (No. 5)	-7350K	75.00
10N48	3/8" (No. 6)	-7340K	75.00
10N47	7/16" (No. 7)	-7330K	75.00
10N46	1/2" (No. 8)	-7320K	75.00
10N45	5/8" (No. 10)	-7310K	75.00
10N44	3/4" (No. 12)	-7300K	75.00

Tig Torches

Whether water or air cooled, all Kennedy Tig torches are lightweight and durable. They come supplied with a 12.5ft (3.8m) cable, and silicon rubber rigid or flexible head mouldings for greater heat resistance.



Tig Torches - Come complete with a 12.5ft 3.8m cable

Product Number	Type & Size	Order Code KEN-885	Price/1 TB
TTS017	Standard Rigid Head Tig Torch 150DC/120AC - Air Cooled	-3200K	2456.00
TTF017	Flexible Head Tig Torch 150DC/120AC - Air Cooled	-3300K	2658.00
TTS018	Standard Rigid Head Tig Torch 350DC/250AC - Water Cooled	-3220K	3215.00
TTS026	Standard Rigid Head Tig Torch 200DC/160AC - Air Cooled	-3240K	4382.00
TTF026	Flexible Head Tig Torch 200DC/160AC - Air Cooled	-3340K	4674.00

Torch Bodies

Made from tough ABS plastic with a silicone rubber head for greater heat resistance and durability.

WP17	WP17 Standard torch body	-6500K	415.00
WP18	WP18 Standard torch body	-6520K	502.00
WP26	WP26 Standard torch body	-6540K	502.00
WP17FX	WP17 Flexi torch body	-6510K	415.00
WP26FX	WP26 Flexi torch body	-6550K	647.00

Back Caps

BIN57Y_ _ To suit WP17/18/26 torches.



Product Number	To Suit	Order Code KEN-885	Price/1 TB
57Y04	Short	-7710K	59.00
57Y02	Long	-7700K	47.00

AC/DC TIG Welding Spares Kit

Can be used in AC or DC processes. Excellent arc starts at low amperages, popular in such applications as orbital tube and pipe manufacturing, thin sheet metal work or jobs where small and delicate parts are welded. Like Thoriated electrodes, they are best used to weld carbon and stainless steels, nickel alloys and titanium. Suitable for WP17, 18 and 26 Tig torches.

Contents:

- 5x 1.6mm collets,
- 5x 1.6mm collet bodies,
- 5x 2.4mm collets,
- 5x 2.4mm collet bodies,
- 2x No.4 ceramic cups,
- 2x No.5 ceramic cups,
- 2x No.6 ceramic cups,
- 2x No.7 ceramic cups,
- 2x No.8 ceramic cups,
- 1x long back cap,
- 1x short back cap,
- 1x 1.6mm ceriated grey tungsten electrode,
- 1x 2.4mm ceriated grey tungsten electrode.

**34
PIECES**



Suitable For	Order Code KEN-885	Price/1 TB
WP17, 18 & 26 Tig torches	-3400K	1339.00

Cup Gaskets

Product Number	To Suit	Order Code KEN-885	Price/1 TB
18CG	WP17/18/26	-7400K	93.00

Gas Lens Body

45V24/25/26/27
To suit WP17/18/26 torches.

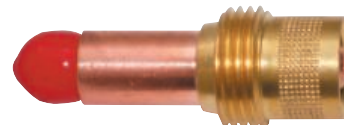

Product Number	Bore Size	Order Code KEN-885	Price/1 TB
45V24	1.0mm (0.040")	-7500K	251.00
45V25	1.6mm (1/16")	-7510K	262.00
45V26	2.4mm (3/32")	-7520K	274.00
45V27	3.2mm (1/8")	-7530K	297.00

Gas Lens Ceramics

54N_ _ To suit WP17/18/26 torches.



Product Number	Bore Size	Order Code KEN-885	Price/1 TB
54N18	1/4" (No. 4)	-7640K	47.00
54N17	5/16" (No. 5)	-7630K	47.00
54N16	3/8" (No. 6)	-7620K	47.00
54N15	7/16" (No. 7)	-7610K	47.00
54N14	1/2" (No. 8)	-7600K	47.00
54N19	5/8" (No. 10)	-7650K	47.00

Gas Lens Heatshield

54N01

Product Number	Type	Order Code KEN-885	Price/1 TB
54N01	Gas Lens Heatshield	-7560K	677.00

GROUP 880 MIG/MAG WELDERS

KENNEDY Panther™ Dual Mig Welder

EMW-120

50A-120A (DC) Output range. A high power single phase welder that operates from a standard 240V household outlet. Automatic wire speed control with manual override. Professional torch with trigger-controlled power and gas prevents undesired arcing and gas wastage. Low current performance - able to deliver a 50A minimum output for welding thin material easily. Accepts both 0.7kg and 5kg spools for maximum portability and economy. Heavy duty redesigned case for durability combined with low weight and portability. Can be used for flux (no gas) and Mig/Mag (gas) welding. Supplied complete with a smooth action, twin roller feed unit, accessories, integrated carrying handle and 2m mains cable. Suitable for automotive, farm, maintenance and contractor use. Conforms to **TUV-GS, GOST, EMC, LVD** and all relevant **CE** requirements. Insulation class H. Protection degree IP21.

Welding capacity: steel wire: 0.6 - 0.8mm, stainless steel wire: 0.8mm, aluminium wire: 0.8mm, flux cored welding wire: 0.8 - 0.9mm. Maximum reel size 5kg.

Contents:

- Panther™ EMW-120 power supply.
- 1.8m cable, 10mm².
- Earth clamp.
- 2m Mig torch.
- Flux cored wire coil 0.9mm x 0.2kg.
- Hand held face shield with 51 x 107mm glass.
- Scratch brush and slag remover.
- Instruction manual.

Input voltage: 230V, 50/60Hz.

Fuse rating: 10A.

Phase: 1.

Power consumption: 3.6kW max. (1.3kW @60%).

Output current range: 50A - 120A (DC).

Open circuit voltage: 30V.

Dimensions (L x W x H): 480 x 275 x 380mm.

Product Number	Current Range	Weight each	Order Code KEN-880	Price/1 TB
Panther™ EMW120	50A - 120A	24.0kg	-1920K	22145.00

Accessories:

Shielding gas for use with most Mig wires. Bottles shown are also suitable for use with Migmates and similar welders.

Connection Kit contains:

1x mini gas regulator,
 1/16" ID x 600mm tube,
 3/16" ID x 200mm tube,
 1/16" x 3/16" hose reducer,
 2x 8 - 12mm hose clips.

Gas Type	Contents	Order Code KEN-885	Price/1 TB
Connection Kit		-2400K	2924.00
Description	Order Code KEN-884	Price/1 TB	
Regulator	-4010K	1464.00	

Leopard™ Dual Mig Welder

EMW-150

30A-145A (DC) Output range. Automatic wire speed control with manual override. Professional torch with trigger-controlled power and gas prevents undesired arcing and gas wastage. Extra low current performance - able to deliver a 30A minimum output for welding very thin material easily. Accepts 0.7kg or 5kg spools for maximum portability and economy. Heavy duty case for durability. Can be used for flux (no gas) and Mig/Mag (gas) welding.

Supplied complete with a smooth action, twin roller feed unit, accessories, 2m mains cable. Suitable for automotive, farm, maintenance and contractor use. Conforms to **TUV-GS, GOST, EMC, LVD** and all relevant **CE** requirements. Insulation class H. Protection degree IP21.

Welding capacity: steel wire: 0.6 - 0.8mm, stainless steel wire: 0.8mm, aluminium wire: 0.8 - 1.0mm, flux cored welding wire: 0.8mm 1.2. Maximum reel size 5kg.

Contents:

- Leopard™ EMW-150 power supply.
- 1.8m cable, 10mm².
- Earth clamp.
- 2m Mig torch.
- Flux cored wire coil 0.9mm x 0.2kg.
- Hand held face shield with 51 x 107mm glass.
- Scratch brush and slag remover.
- Instruction manual.

Input voltage: 230V, 50/60Hz. Single phase.

Power consumption: 3.7kW max. (1.4kW @60%).

Fuse rating: 16A.

Output current range: 30A - 145A (DC).

Open circuit voltage: 31V.

Dimensions (L x W x H): 680 x 285 x 410mm.

Product Number	Current Range	Weight each	Order Code KEN-880	Price/1 TB
Leopard™ EMW150	30A - 145A	27.5kg	-1940K	25235.00



See page 708 for additional Torches

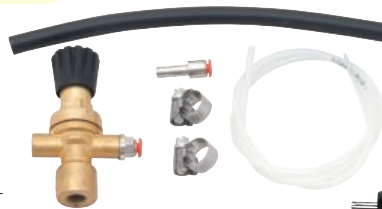

READY TO WELD

TWIN ROLLER FEED TURBO FAN COOLED

LOW CURRENT 2 YEAR WARRANTY

COMPATIBLE WITH BINZEL® B15 TORCH SPARES GAS NO GAS



Gas Bottles are Supplied Separately



See page 708 for additional Torches

READY TO WELD

TWIN ROLLER FEED TURBO FAN COOLED

LOW CURRENT 2 YEAR WARRANTY

COMPATIBLE WITH BINZEL® B15 TORCH SPARES GAS NO GAS

Gas Bottles are Supplied Separately

WELDING

KENNEDY *Tiger™ Compact Mig Welder*
QUALITY INDUSTRIAL TOOLING

TIGER



WELDING

EMW-170

Heavy-duty transformer and turbo fan cooling allows welding at higher power for longer periods. Automatic wire speed control with manual override for continuous and spot welding. Professional torch with trigger-controlled power and gas prevents undesired arcing and gas wastage. Extra low current performance - able to deliver a 30A minimum output for welding very thin material easily. Accepts 0.7kg, 5kg and 15kg spools for maximum portability and economy. Heavy duty case for durability. Mig/Mag (gas) welding only. Six position, stepped voltage regulator allows process selection to be pre-set. Supplied complete with a smooth action, twin roller feed unit, two large diameter solid wheels and 2m mains cable. Suitable for automotive, farm, maintenance and contractor use. Conforms to **TUV-GS, GOST, EMC, LVD** and all relevant **CE** requirements. Insulation class H. Protection degree IP21.

Welding capacity: steel wire 0.6 - 0.8mm, stainless steel wire 0.8mm, aluminium wire 0.8 - 1.0mm.
Maximum reel size: 15kg.
Input voltage: 230V, 50/60Hz.
Fuse rating: 16A.

Phase: 1.
Power consumption: 5.2kW (2.3 kW @60%).
Output current range: 30A - 170A (DC).
Open circuit voltage: 31V.
Product dimensions (L x W x H): 80 x 45 x 57cm.
Box dimensions (L x W X H): 84 x 35 x 52cm.

Contents:

- Tiger EMW-170 power supply.
- 1.5m cable, 16mm².
- Earth clamp.
- 2.4m MIG torch.
- Mig wire reel 0.8mm x 0.2kg.
- Instruction manual.

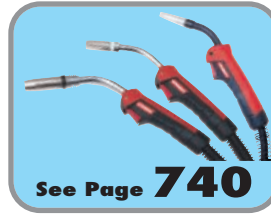

READY TO WELD

TWIN ROLLER FEED **TURBO FAN COOLED**

LOW CURRENT **2 YEAR WARRANTY**

COMPATIBLE WITH BINZEL® B15 TORCH SPARES

Product Number	Current Range	Weight each	Order Code KEN-880	Price/1 TB
Tiger™ EMW170	30A - 170A	38kg	-1960K	45320.00

Lion™ Compact Mig Welder

LION

EMW-220

Heavy-duty transformer and turbo fan cooling allows welding at higher power for longer periods. Automatic wire speed control with manual override. Professional torch with trigger-controlled power and gas prevents undesired arcing and gas wastage. The torch cable can be detached from the machine. 35A minimum output. Accepts 0.7kg, 5kg and 15kg spools for maximum portability and economy. Heavy duty case for durability. Mig/Mag (gas) welding only. Six position, stepped voltage regulator allows process selection to be pre-set. Supplied complete with a smooth action, twin roller feed unit, two large diameter solid wheels and 2m mains cable. Suitable for automotive, farm, maintenance and contractor use. Conforms to **TUV-GS, GOST, EMC, LVD** and all relevant **CE** requirements. Insulation class H. Protection degree IP22.

Welding capacity: steel wire 0.6mm - 1mm, stainless steel wire 0.8mm, aluminium wire 0.8mm - 1.0mm.
Maximum reel size: 15kg.
Input voltage: 230V, 50/60Hz.
Fuse rating: 16A.

Phase: 1.
Power consumption: 3.7kW max. (1.4kW @60%).
Output current range: 30A - 220A (DC).
Open circuit voltage: 17.8 - 34V.
Product dimensions (L x W x H): 78 x 45 x 71cm.
Box dimensions (L x W X H): 84 x 35 x 57cm.

Contents:

- Lion EMW-220 power supply.
- 1.5m cable, 16mm².
- Earth clamp.
- 2.5m Mig torch.
- Mig wire reel 0.8mm x 0.2kg.
- Instruction manual.

See page 708 for additional Torches



READY TO WELD

TWIN ROLLER FEED **TURBO FAN COOLED**

LOW CURRENT **2 YEAR WARRANTY**

COMPATIBLE WITH BINZEL® B15 TORCH SPARES

Product Number	Current Range	Weight each	Order Code KEN-880	Price/1 TB
Lion™ EMW220	30A - 220A	45kg	-1980K	60294.00

Feed Rollers for Kennedy Tiger & Lion Mig Welders

Description	Weight each	Order Code KEN-898	Price/1 TB
0.6 - 0.8mm Feed Roller		-2800K	186.00

PRODUCTS ARE ONLY AVAILABLE VIA YOUR DISTRIBUTOR

GROUP 885 MIG WELDER ACCESSORIES & SPARES

KENNEDY Euro Connection Torches
QUALITY INDUSTRIAL TOOLING

Fitted with EURO connectors, with insulated gas nozzles for use with mixed gases and a 4m supple, lightweight cable to improve productivity.

4m CABLE WITH FITTED LINER & STANDARD TIP



MTE-154 suits Kennedy Panther and Leopard.
 MTE-254 suits Kennedy Tiger and Lion.



Product Number	Max. Rating	Wire Sizes (mm)	Standard Tip Size	Cable Length	Order Code KEN-885	Price/1 TB
MTE154	150A	0.6 - 1.0	0.8mm	4m	-3080K	6236.00
MTE254	230A	0.8 - 1.2	1.0mm	4m	-3100K	6307.00
MTE364	340A	0.8 - 1.2	1.2mm	4m	-3120K	8759.00

Mig Torch Liners

PVC-coated for use with steel wire. Colour-coded to indicate wire size:
0.6 - 0.9mm = Blue,
1.0 - 1.2mm = Red.



Length (m)	Product Number	For Wire Size (mm)	Order Code KEN-883	Price/1 TB
3	124.0011	0.6 - 0.9	-7010K	181.00
3	124.0026	1.0 - 1.2	-7040K	181.00
4	124.0012	0.6 - 0.9	-7020K	181.00
4	124.0031	1.0 - 1.2	-7050K	181.00

ANM Cutting Nozzles

Acetylene nozzle mix can be used with the majority of popular cutting torches. Plate thickness refers to mild steel.



Nozzle Diameter	Plate Thickness	Order Code KEN-883	Price/1 TB
1/32"	6mm	-2010K	271.00
3/64"	12mm	-2020K	271.00
1/16"	75mm	-2030K	271.00
5/64"	100mm	-2040K	271.00
3/32"	150mm	-2050K	271.00
1/8"	300mm	-2060K	271.00

90° Welding Angle Clamp

One man set up and operation, made from cast iron, copper plated spindle for spatter protection, T-Handle enables high pressure for secure clamping, easy fixing to a workbench or machine tool table.

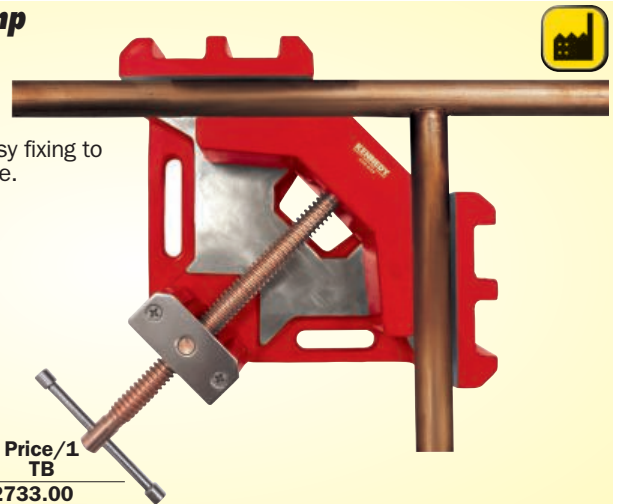

Capacity (mm)	Weight each	Order Code KEN-539	Price/1 TB
60mm	5.3kg	-0360K	2733.00
90mm	10.5kg	-0390K	3553.00



Mig Torch Accessories

Contact Tips & Tip Adaptors



Compatible with Parweld and Binzel Torches.

For Torch Number	Product Number	For Wire Size (mm)	Order Code KEN-883	Price/1 TB
MTE 154	140.0008	0.6	-7120K	28.00
	140.0059	0.8	-7240K	36.00
	140.0253	1.0	-7360K	36.00
MTE 154/254/364	140.0051	0.8	-7200K	28.00
	140.0054	0.8 H.Duty	-7220K	41.00
	140.0242	1.0	-7300K	28.00
	140.0245	1.0 H.Duty	-7320K	41.00
	140.0379	1.2	-7400K	28.00
MTE 254	142.0001	Tip Adaptor	-7500K	169.00

Nozzles

Conical



Tapered



For Torch Number	Product Number	Style	Order Code KEN-883	Price/1 TB
MTE15-4	145.0075	Conical	-7600K	181.00
	145.0076	Conical	-7610K	181.00
MTE254	145.0124	Tapered	-7640K	181.00
STD364	145.0078	Conical	-7620K	297.00

PNM Cutting Nozzles

75mm long propane nozzle mix can be used with the majority of popular cutting torches.

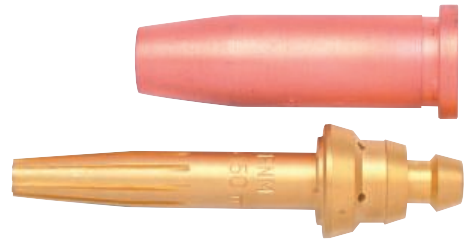

Nozzle Diameter	Plate Thickness	Order Code KEN-883	Price/1 TB
1/32"	6mm	-2110K	232.00
3/64"	12mm	-2120K	232.00
1/16"	75mm	-2130K	232.00
5/64"	100mm	-2140K	232.00
3/32"	150mm	-2150K	232.00
1/8"	300mm	-2160K	232.00



KENNEDY **A18 Mig Wire Reels**
QUALITY INDUSTRIAL TOOLING

Deposits C - 1.3% Mn weld metal for mild and medium tensile steels. Copper coat finish and double deoxidised. For use with CO₂ or Ar-CO₂ shielding gas. Made to **BS 2901/1 : 1983 A18 & BS EN 440 G3 Si1**. For welding mild steel and C-Mn steels such as boilers, tanks, pipework, machinery, vehicle chassis fabrication and shipbuilding. 0.7kg and 5.0kg reels are random wound. Both sizes are designed and packaged for use on Kennedy Dual Mig welders, Mini Migs, Migmates etc. Use with CO₂ or Ar-CO₂ shielding gas.



0.7kg Mini Reels

FOR MILD STEEL & C-Mn STEEL

A18 BS 2901

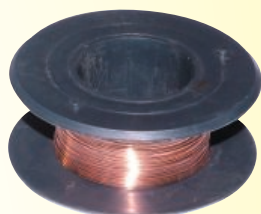

Product Number	Wire Dia.	Order Code KEN-887	Price/1 TB
A18-060-0.7	0.6mm	-1860K	266.00
A18-080-0.7	0.8mm	-1880K	266.00
A18-100-0.7	1.0mm	-1900K	368.00

5.0kg Reels

FOR MILD STEEL & C-Mn STEEL

A18 BS 2901

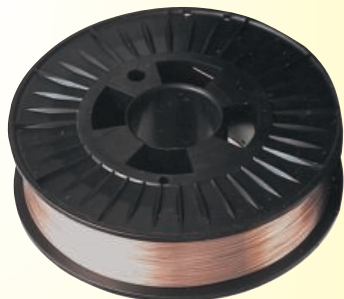

Product Number	Wire Dia.	Order Code KEN-887	Price/1 TB
A18-060-5.0	0.6mm	-1960K	1380.00
A18-080-5.0	0.8mm	-1980K	1380.00
A18-100-5.0	1.0mm	-2000K	1167.00

15kg Reels

Use with CO₂ or Ar-CO₂ shielding gas.

FOR MILD STEEL & C-Mn STEEL

PLW 15kg Reels

A18 BS 2901

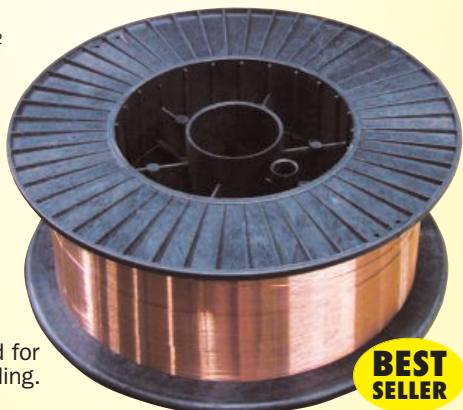

BEST SELLER

*Precision layer wound for positive snag free feeding.

Product Number	Wire Diameter	Order Code KEN-887	Price/1 TB
*A18-060-15.0	0.6mm	-2060K	3714.00
*A18-080-15.0	0.8mm	-2080K	3793.00
*A18-100-15.0	1.0mm	-2100K	4085.00
*A18-120-15.0	1.2mm	-2120K	4085.00

Flux Core Gasless Wire

General-purpose Mig wire with self-shielding flux core, allowing it to be used without the need for a separate shielding gas. Designed and packaged specifically for use on Kennedy Dual Mig welders, Mini Migs, Migmates etc. For welding mild steel and C-Mn steels such as boilers, tanks, pipework, machinery, vehicle chassis fabrication. 0.8mm diameter mini reels. Random wound and not layer wound.



FOR MILD STEEL & C-Mn STEEL

A18 BS 2901

Product Number	Reel Size	Order Code KEN-887	Price/1 TB
FCG-080-0.45	0.45kg	-1620K	759.00
FCG-080-0.9	0.90kg	-1640K	1249.00

Stainless Steel Mig Wire

Ideal for welding stainless steels. It has increased silicon content for an improved weld that produces a smoother more consistent bead making it ideal for use where appearance is important. For use on stainless steel structures. Supplied on a precision layer wound reel for positive uninterrupted feeding. **Weight: 15kg.**

FOR STAINLESS

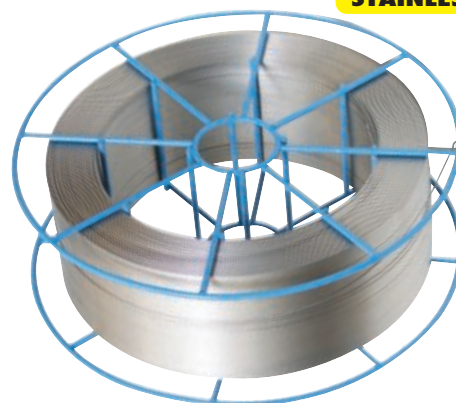

Type	Wire Diameter	Order Code KEN-887	Price/1 TB
308LSi	0.8mm	-0520K	12201.00
308LSi	1.0mm	-0530K	12201.00
309LSi	1.0mm	-0570K	12201.00
316LSi	0.8mm	-0540K	11670.00
316LSi	1.8mm	-0550K	11670.00
316LSi	1.2mm	-0560K	12201.00

MIG Wire - All prices are subject to possible surcharges due to continued volatility of material costs. Please contact your local branch for details.

Individual Fitted Welding Hoses

Kink and crush resistant hoses with industry standard 3/8" BSP fittings on the regulator end. Hoses have safety check valves at the torch end to resist flashbacks. Oxygen fittings are right hand thread, fuel gas fittings are left hand thread. Manufactured to **EN 559/BS EN ISO 3821**.

- OXYGEN - Blue Hose, right hand thread.**
- ACETYLENE - Red Hose, left hand thread.**
- PROPANE - Orange Hose, left hand thread.**

NEW

Individual Fitted Welding Hoses EN 559/BS EN ISO 3821

Hose Size	Length	DSCV	Reg. Nut	OXYGEN		ACETYLENE		PROPANE	
				Order Code CTL-885	Price/1 TB	Order Code CTL-885	Price/1 TB	Order Code CTL-885	Price/1 TB
6mm	5m	1/4"	3/8"	-7950A	899.00	-7958A	799.00	-	-
6mm	10m	1/4"	3/8"	-7950B	1750.00	-7958B	1650.00	-	-
6mm	20m	1/4"	3/8"	-7950D	3400.00	-7958D	3300.00	-	-
6mm	5m	3/8"	3/8"	-7951A	1800.00	-7959A	1700.00	-7967A	1900.00
6mm	10m	3/8"	3/8"	-7951B	1850.00	-7959B	1750.00	-7967B	2450.00
6mm	20m	3/8"	3/8"	-7951D	3500.00	-7959D	3400.00	-	-
8mm	5m	3/8"	3/8"	-7953A	1250.00	-7961A	1150.00	-	-
8mm	10m	3/8"	3/8"	-7953B	2250.00	-7961B	2150.00	-	-
8mm	20m	3/8"	3/8"	-7953D	3600.00	-7961D	3500.00	-	-
10mm	5m	3/8"	3/8"	-7955A	1350.00	-7963A	1250.00	-7971A	2300.00
10mm	10m	3/8"	3/8"	-7955B	2500.00	-7963B	2400.00	-7971B	2750.00
10mm	20m	3/8"	3/8"	-7955D	3700.00	-7963D	3600.00	-7971D	3900.00



WELDING

MATLOCK Cylinder Trolleys

Robust, heavy gauge steel, welded construction, with two large diameter wheels and solid tyres. For use with oxygen and/or acetylene cylinders. 16" pneumatic tyre.



For Use With	Cylinder Capacity	Order Code MTL-985	Price/1 TB
Propane	1	-3000K	3182.00
Oxy/Acetylene	1	-3020K	3278.00
Oxy/propane	2	-3040K	3826.00
Oxy/Acetylene	2	-3060K	3826.00

KENNEDY Nozzle Cleaner Set

Prolongs the life of gas welding and cutting nozzles. High strength, needle type files housed in an anodised aluminium flip-up pocket case.



Product Number	Weight each	Order Code KEN-883	Price/1 TB
1216	20g	-2500K	551.00

Pistol Type Spark Lighter

For easy and rapid single-handed ignition of welding and cutting torches. Metal bodied. Uses standard cigarette lighter flints.



Style	Pack Quantity	Order Code KEN-885	Price/1 TB
Pistol	1	-7050K	265.00
Flints	10	-7060K	50.00

Cup-Type Spark Lighter

For easy and rapid single-handed ignition of welding and cutting torches.

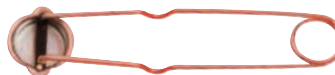

Style	Pack Quantity	Order Code KEN-885	Price/1 TB
Cup	1	-7010K	129.00
Flints	10	-7020K	73.00

Triple Flint Type Spark Lighter

For easy and rapid single handed ignition of welding and cutting torches.

When one flint wears, turn the triangular head to use the next flint.



Style	Pack Quantity	Order Code KEN-885	Price/1 TB
Triple	1	-7110K	99.00
Flints	1 Head	-7120K	30.00

Oxygen Regulators

Designed with 2 gauges to indicate cylinder contents and outlet pressure.



4.0 Bar Oxygen Regulator

Full 300 bar capacity.

10.0 Bar Oxygen Regulator

Full 300 bar capacity.

Bottom entry design, which is suited for top outlet cylinder valves. Fitted with 1/4" parallel threaded gauges, standard 3/8" BSP outlet and 5/8" BSP inlet connections.



Gas Type	Order Code KEN-884	Price/1 TB
10.0 Bar Oxygen	-4120K	2658.00
4.0 Bar Oxygen	-4140K	2658.00

Argon & Acetylene Regulators

Designed with two gauges to indicate cylinder contents and outlet pressure. Argon regulator outlet gauge is calibrated for flow 0 - 35lpm. Acetylene regulator has a calibrated flow rate of 0 - 1.5 bar with a full 250 bar capacity.

Features:

Flow rates up to 80m³/h (2824 ft³/h) 300 bar capability. Features 2 gauges displaying cylinder contents and pressure. Bottom entry design suited for top outlet cylinder valves.

Fitted with 1/4" parallel threaded gauges. Fitted with standard 3/8" BSP outlet. Fitted with 5/8" BSP inlet connections.



Gas Type	Order Code KEN-884	Price/1 TB
Acet. Regulator	-4200K	2658.00
Argon Regulator	-4300K	2658.00

KENNEDY *PVC Welding Curtains*
QUALITY INDUSTRIAL TOOLING

PVC curtains for suspension from curtain poles. Standard sized curtains with snap-fasteners on both sides for joining to obtain total desired width. Supplied with reinforced holes in the upper edge and steel suspension rings. All standard curtains are made of pliable, self-extinguishing PVC material with flash point 320 - 390°C. **EN1598** for welding (fulfilling requirements on transmittance, reflectance, UV-stability and resistance to ignition). Supplied with steel curtain rings.



Colour	Size W x H (mm)	Order Code KEN-885	Price/1 TB
Dark Green Reinforced	1300 x 1800	-8640K	4775.00
Amber Hi-Vis	1300 x 1800	-8740K	4775.00
Green Polished	1300 x 1800	-8940K	4775.00
Dark Green Reinforced	1300 x 2400	-8660K	5305.00
Green Polished	1300 x 2400	-8960K	5305.00
Dark Green Reinforced	1300 x 2800	-8680K	6896.00
Green Polished	1300 x 2800	-8980K	9018.00
Amber Hi-Vis	1400 x 2400	-8780K	7957.00

SOLENT *Flaw Inspection System*
MAINTENANCE

Fast reliable method for visually inspecting and spot-checking surfaces of welds, exotic alloys or standard metals, highly stressed structural members, critical castings, shafts, gears, spindles, and any other hard part where identification of surface flaws is essential. Detects flaws such as cracks, pin holes, welding laps and porosity either during manufacture or on-site. A three-part system.

SF1-500B is a cleaner.

SF2-500B is a dye penetrant.

SF3-500B is a developing fluid that reacts with the dye in SF2-500B to show small cracks in the weld. Each part supplied in an ozone friendly 500ml aerosol.



Flaw Detector Cleaner Spray

SF1-500B

Quick drying, powerful solvent for cleaning surfaces prior to testing. Removes contaminants including oils, greases and grime.

Product Number	Size	Order Code SOL-732	Price/1 TB
SF1-500B	500ml	-0240K	944.00

Flaw Detector Dye Penetrant

SF2-500B

Highly sensitive red dye, for use when detecting flaws on metal components under normal lighting conditions.

Product Number	Size	Order Code SOL-732	Price/1 TB
SF2-500B	500ml	-0260K	944.00

**BIG VALUE
500ml Cans!**

Flaw Detector Developer

SF3-500B

White film to highlight any faults which have been detected when using Flaw Detector Penetrant. The product should be removed using Flaw Detector Cleaner Spray once cracks have been found and marked.

Product Number	Size	Order Code SOL-732	Price/1 TB
SF3-500B	500ml	-0280K	944.00

Welder's Anti-Spatter Spray

SW1-400C

Solvent-based coating that is applied to metal before welding to prevent spatter from sticking to the metal. CO₂ gas propelled aerosol. Totally non-flammable. Silicone free and easily removed with solvents prior to galvanising or painting.



Product Number	Size	Order Code SOL-732	Price/1 TB
SW1-400C	400g	-0840K	346.00

Maintenance Welder's Anti-Spatter Fluid

Reduces the risk of joint puddling and greatly reduces preparation time prior to final painting. Does not affect any subsequent galvanising or painting operations. Evaporates under normal weld temperatures. Dichloromethane and silicone-free. Non-flammable, non-toxic, non-corrosive and biodegradable.



WATER-BASED

Size	Order Code SOL-732	Price/1 TB
5ltr	-9300K	567.00
20ltr	-9310K	1545.00

PRODUCTS ARE ONLY AVAILABLE VIA YOUR DISTRIBUTOR

KENNEDY Automatic Welding Helmets
QUALITY INDUSTRIAL TOOLING

Automatically protects the operator from eye injuries caused by arc, leaving both hands free. Equipped with two sets of photosensors to sense arc light. Solar power relieves the need for batteries. Offers permanent UV/IR protection up to **DIN 15** whilst in use. Welding shade can be easily selected by way of a side mounted adjustment dial. Automatically detects weld arc and switches from shade 4 to pre-selected shade (9, 10, 11, 12 or 13). Time to dark: 0.5ms. The shells are certified to **BS EN 175: 1997** for eye and face protection. They can withstand a temperature of 650°C from the end of the electrode for five seconds, without burning. The electronic lenses are certified to **DIN EN 169** and **DIN 179**. Solar powered, no battery required. Suitable for Arc, Mig/Mag, Tig and Plasma welding.
With 2 year warranty.

WELDING



Light to dark
0.5 milliseconds



Type	Weight each	Order Code KEN-885	Price/1 TB
Auto variable 9 - 13	480g	-5020K	6132.00

Spare Cover Lenses

To protect liquid crystal cartridge unit. Supplied in packs of 10.

Cover Lens	Type	Size	Order Code CTL-885	Price/Pk TB
Inner		107 x 45mm	-7983K	467.00
Outer		110 x 90mm	-7983E	467.00

Large View Welding Helmets

Durable, lightweight material is corrosion resistant and flame retardant. External sensitivity control provides clear vision both prior and during welding. Ultra high performance filters protect against UV and IR. Auto darkening lens automatically changes from light to dark shade when arc is struck. Special turnover headband mechanism offers greater comfort and reduces fatigue. Suitable for all kinds of welding types, including Tig low amperage welding, and can be used for grinding. High impact glass for increased safety. Dual powered: Solar and battery. Complies with **DIN, ISO, EN379** safety standards and **ANSI Z 87.12** standards.

View Field: 98 x 55mm
UV/IR protection: DIN16
Light State: DIN4
Variable Shade: DIN9 - DIN13
Reaction Time: 0.00005 Sec
Delay Time: 0.3 Sec - 0.9 Sec
Sensors: Four infrared detectors
Power Supply: Solar cells + CR2450 lithium battery (supplied PAN-904-2550K)
Power: On/Off Fully Automatic
Operating temperature: -5°C - 55°C (23°F - 131°F)
Storing temperature: -20°C - 70°C (-4°F - 158°F)



Light to dark
0.5 milliseconds



Pattern	Order Code KEN-885	Price/1 TB
Plain Black	-5100K	4775.00
Union Jack	-5120K	4775.00

Jet Black Auto X

The Kennedy Jet Black™ welding helmet is designed using the latest technology to automatically protect the user's eyes from arc light damage and leave both hands free to increase accuracy, efficiency and therefore productivity. Fitted with automatic filters that are transparent before welding, it enables the operator to observe the workpiece clearly. When striking the arc, the filter darkens automatically with immediate effect. When the arc goes out, the filter will become transparent again. The switching time from light to dark is approximately 0.0001 seconds, and the switching time from dark to light may be set at between 0.1 - 0.5 second.

Dual power: battery and solar.
Light to dark: 0.0001 seconds
Dark to light: 0.1 - 0.5 seconds

Control switching from shade to shade 8 - 12. Auto on/off power source provided by two lithium batteries giving approx. 800 hours of working. High impact resistance. Clear view filter. Permanent UV/IR protection up to **DIN 16**. Complete with additional sweat band. Lightweight - less than 0.5kg.



Light to dark
0.1 milliseconds



Type	Weight each	Order Code KEN-885	Price/1 TB
Auto variable 8 - 12	480g	-5060K	6425.00

Welder's Helmets

The entry level to the Kennedy helmet range, both lift up over brow strap when not in use and accept plain and tinted lenses which are available separately.

Lens size: 4¼" x 3¼".



Visor Type	Weight each	Order Code KEN-885	Price/1 TB
Flip-up	434g	-7150K	397.00
Fixed	434g	-7160K	286.00

Lenses to Suit Helmets & Shields

To protect the user from UV rays and weld spatter. *Standard UK size.

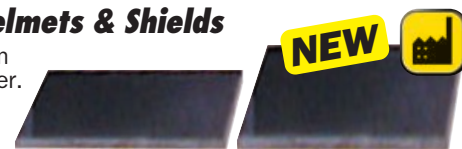

Lens Size	Type	Colour/ Shade	Order Code KEN-885	Price/1 TB	
4¼" x 3¼"	Green Shaded	Sh. 8	-7412K	52.00	
		Sh. 9	-7413K	52.00	
		Sh. 10	-7414K	52.00	
		Sh. 11	-7415K	52.00	
		Sh. 12	-7416K	52.00	
		Sh. 13	-7417K	52.00	
	Polycarbonate	Clear	-7419K	52.00	
		CR39 Antisplatter	-7418K	52.00	
		Glass	-7411K	26.00	
	4¼" x 2"	Green Shaded	Sh. 9	-7399K	26.00
			Sh. 10	-7402K	31.00
			Sh. 11	-7401K	31.00
	4¼" x 2"	Polycarbonate	Clear	-7407K	31.00
CR39 Antisplatter			-7408K	31.00	
Glass			-7409K	26.00	
110 x 60mm	Green Shaded	Sh. 11	-7422K	57.00	
		Polycarbonate	-7426K	31.00	
110 x 90mm	Antisplatter	Clear	-7448K	67.00	
4½" x 5¼"	CR39 Antisplatter	Clear	-7481K	102.00	

KENNEDY
PERSONAL PROTECTION



Reversible Welder's Gauntlet

Reversible (ambidextrous) lined, green welder's gauntlet, type A.
CE approved to **EN12477, EN388, EN407.**

Size: 10.

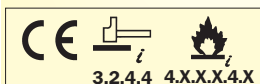

Size	Weight per Pr	Order Code	Price/Pr TB
10	250g	KEN-961	-1940K 387.00

TUFFSAFE



Heavy Duty Welder's Gauntlet

Full five finger welder's gauntlet manufactured from select split leather with a full cotton lining with a one piece back. Reinforced palm and thumb for increased wear with no exposed seams to burn. Kevlar® sewn throughout. Tested to **EN388: 2003 & EN407: 2004.**

Size: 10.

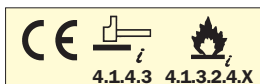

Size	Weight per Pr	Order Code	Price/Pr TB
10	341g	TFF-961	-1580K 514.00

Grey Leather Tig Welder's Gloves



Constructed from soft high quality nappa leather for the palm, and stiff 150mm chrome leather cuff. The soft leather palm and fingers offer a superb feel and good durability for precision welding. Good comfort and flexible with a good level of dexterity. 360mm overall length. Approved to **EN388: 2.1.2.2 - EN12477: Type B - EN420: Dexterity Level 5.**

Size: 10.

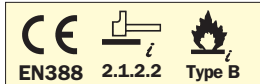

Size	Weight per Pr	Order Code	Price/Pr TB
10	345g	TFF-961	-1650K 318.00

KENNEDY
PERSONAL PROTECTION

Chrome Leather Welder's Clothing

A range of economically priced rugged workwear manufactured from high quality selected chrome leather. Spatter-resistant and tear-resistant. The full range offers head-to-toe protection against weld spatter and grinding sparks. Suitable for use in workshops, foundries and on-site.

Jackets

Stud fastening jacket for full neck to waist protection against weld spatter and grinding sparks. With external side pocket, neck is lined with soft split leather for extra comfort. All seams have heavy duty stitching for durability and extended wear.

CE approved to **EN470-1 CAT II.**



Now Available in RED

Colour	Size	Order Code	Price/1 TB
Grey	Large	-8160K	1957.00
Grey	X-Large	-8170K	1957.00
Red	Large	-5222K	2215.00
Red	X-Large	-5223K	2318.00

Aprons

Generous fit for full torso and upper leg protection against weld spatter and grinding sparks, whilst offering freedom of movement for the wearer. All seams have heavy duty stitching for durability and extended wear. Available in a choice of tie or buckle fastening.

CE approved to **EN470-1 CAT II.**

Colours: available in a choice of grey or red.



Now Available in RED

Colour	W x L (cm)	Order Code	Price/1 TB
Tie Fastening			
Grey	60 x 90	-8020K	585.00
Grey	60 x 105	-8030K	691.00
Red	60 x 90	-5410K	603.00
Buckle Fastening			
Grey	60 x 90	-8060K	691.00
Red	60 x 90	-5440K	742.00

Sleeves

Can be used independently or in conjunction with an apron or other garment to offer optimum protection of the lower arm and elbow. With elasticated openings. All seams have heavy duty stitching for durability and extended wear. One size.

CE approved to **EN470-1 CAT II.**



Colour	Size	Order Code	Price/Pr TB
Grey	45cm	-8220K	530.00
Red	45cm	-5310K	541.00

Gaiters

For wearing over workshoes to protect against weld spatter and grinding sparks. With velcro fastening on back of calf and buckle adjustment around shoe. Double stitched and riveted seams for extra heavy duty use.

CE approved to **EN470-1 CAT II.**

Size: 35cm.



Size	Order Code	Price/Pr TB
35cm	-8260K	742.00

Welder's Caps

Comfortable, durable and washable welder's caps. Double stitched construction with absorbent cotton sweat band. Can be worn with the peak to the rear when a screen is used. New improved version with taped, reinforced internal seams for extra durability and improved comfort.



Size	Weight each	Order Code	Price/1 TB
WDA-957			
7 1/8"	35g	-5500K	438.00
7 1/4"	35g	-5510K	438.00
7 3/8"	35g	-5520K	438.00
7 1/2"	35g	-5530K	438.00
7 5/8"	40g	-5540K	438.00
7 3/4"	40g	-5550K	438.00

GROUP 741 OIL & CHEMICAL STORAGE



Page **716 - 719**

GROUP 742 SPILL RESPONSE



Page **720 - 729**

GROUP 904 BATTERIES



Page **730**

GROUP 904 TORCHES



Page **731 - 733**

GROUP 937 IDENTITY DISCS



Page **734**

GROUP 941 MECHANICAL LIFTING EQUIPMENT



Page **735 - 737**

GROUP 942 SLINGS



Page **735**

GROUP 945 CASTORS



Page **738 - 739**

GROUP 946 FLOOR MATTING



Page **740 - 741**

GROUP 949 ARCHITECTURAL HARDWARE



Page **742 - 743**

GROUP 950 LOCKOUT & TAGOUT SYSTEM



Page **751**

GROUP 950 PADLOCKS



Page **748 - 751**

GROUP 964 ANTI-SLIP FLOOR TAPES



Page **752**

GROUP 964 HAZARD TAPES



Page **752**

GROUP 978 ROPE, STRAPS & CHAIN



Page **753 - 755**

GROUP 984 TARPULINS



Page **756**

GROUP 985 HANDLING



Page **757 - 759**

GROUP 986 INSULATION TAPE



Page **760**

GROUP 992 TRAFFIC MANAGEMENT



Page **760 - 761**

GROUP 996 FIRST AID



Page **762 - 763**



SITE MAINTENANCE

**Product Groups
714 - 996**

Product Grading



Production

High performance industrial tooling designed for continuous use applications on machine tools where repeatability and long tool life are of critical importance.



Professional

Industrial tooling that has enhanced features and benefits demanded by craftsmen and professional users.



Industrial

Designed for regular use in industrial applications. Manufactured to stringent quality levels and international standards.



Workshop

Standard quality tooling for use by tradesmen and generally industrial use.



Maintenance

Products designed for general maintenance of machines, workshops, garages and some household applications.



Home Improver

DIY quality tooling. Designed for home use and light industrial applications.

Contents

Description	Group	Page
Anti - Slip Floor Tapes	964	752
Architectural Hardware	949	742 - 743
Batteries	904	730
Castors	945	738 - 739
Chalk	910	734
First Aid	996	762 - 763
Floor Matting	946	740 - 741
Hand Brushes	906	734
Handling	985	757 - 759
Hazard Tapes	964	752
Identity Discs	937	734
Insulation Tape	986	760
Lockout & Tagout System	950	751
Mechanical Lifting Equipment	941	735 - 737
Oil & Chemical Storage	741	716 - 719
Padlocks	950	748 - 751
Rope & Chain Fittings	978	754 - 755
Rope, Straps & Chain	978	753
Slings	942	735
Spill Response	742	720 - 729
Tarpaulins	984	756
Torches	904	731 - 733
Traffic Management	992	760 - 761

Oil-Storage Recommendations

Who needs to comply?

Any industrial, commercial or institutional site storing 200 litres or more of oil or fuel above ground in one or more containers.

What is required?

All containers storing oil or fuel, whether a drum, an IBC (Intermediate Bulk Container) or a tank, must be sufficiently banded within themselves or stood on a spill pallet or drip tray with sufficient capacity to contain either 110% of the contents of the largest container or 25% of the total capacity stored, whichever is the greater.



Storing oils and chemicals without the correct safety products in use could leave you with a hefty fine - and a massive clean-up bill!

SITE MAINTENANCE

Does your operation comply with the latest Safety Management Systems?

SOLENT SPILL CONTROL Workflows

- Perfect for machine cleaning and lubrication areas
- Versatile modular systems to allow bespoke configuration.
- All sizes of workflow have the same 15cm height for easier loading and unloading.
- Grates can be removed for cleaning

Workflow Ramp

- Safe for use with any size of workflow
- Integral joining strip ensures that it stays in position
- Ribbed surface for better grip.

EXTENDED RANGE



4 Drum SWL 2700kg

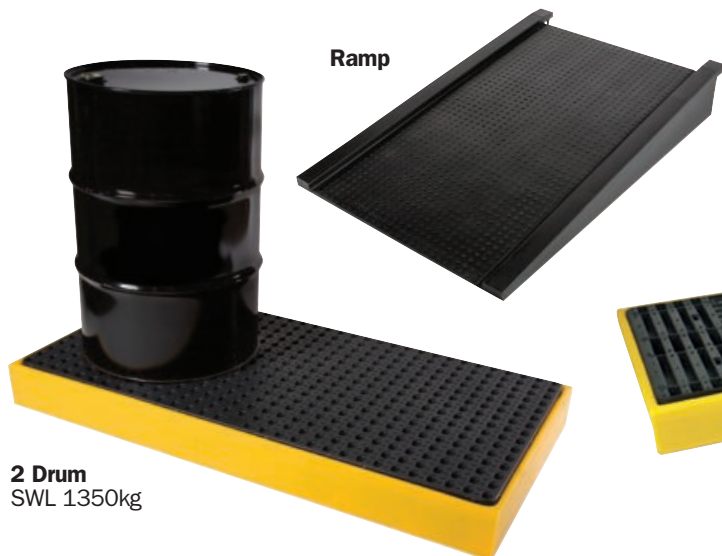

2 Drum SWL 1350kg



4 Drum In-Line SWL 2700kg

Product Number	Size	Dimensions (cm)	Sump (ltr)	Order Code SOL-741	Price/1 TB
SW-2	2 Drum	160 x 80 x 15	120	-6410A	19097.00
SW-4	4 Drum	160 x 160 x 15	250	-6420B	25462.00
SW-4IL	4 Drum In-line	260 x 90 x 15	300	-6421C	36050.00
SWR-1	Ramp	129 x 81 x 18	-	-6520R	12816.00

SOLENT SPILL CONTROL™ Spill Pallets

- Tough 100% high impact polyethylene construction. Corrosion resistant
- Generous sump capacities are large enough to comply with the regulations
- Grates can be removed for cleaning
- **4 Drum** pallet has a low loading height of only 28cm
- **4 Drum In-Line** pallet is ideal for instances where space is at a premium - The unique design allows for the drums to be stored length wise along a wall while still complying with the regulations



2 Drum
SWL 1350kg

4 Drum
SWL 2700kg

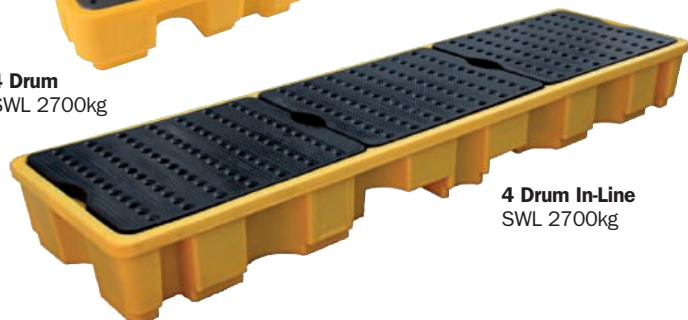

4 Drum In-Line
SWL 2700kg

Product Number	Size	Dimensions (cm)	Sump (ltr)	Order Code SOL-741	Price/1 TB
SDP-2	2 Drum	130 x 75 x 44	250	-5110A	19606.00
SDP-4	4 Drum	139 x 129 x 28	250	-5120A	23346.00
SDP-4L	4 Drum In-line	245 x 66 x 27	240	-5120L	32888.00

All Weather Spill Pallets

A spill pallet full of rain water does not offer much protection should a drum leak. Where pallets are not kept under a shelter, make use of this unique design.

- Includes integral ground anchoring points for stability in exposed locations
- With dual lockable shutter doors allowing access from both sides
- Base fork lift pockets for safe transportation
- Single user friendly with lockable roll door



2 Drum SWL 2700kg



4 Drum SWL 2700kg

Product Number	Size	Dimensions (cm)	Sump (ltr)	Order Code SOL-741	Price/1 TB
SPSP-2	2 Drum	156 x 110 x 211	250	-5920X	97850.00
SPSP-4	4 Drum	156 x 173 x 211	410	-5921Y	108150.00

IBC Spill Pallets

Single IBC Spill Pallet

- Unique design is complete with a dispensing well for the splash-proof dispensing of fluids from the IBC
- Can be used with any type of IBC with an integral pallet

Double IBC Spill Pallet

- The largest polyethylene spill pallet available
- Can be used for a variety of applications including the regulation compliant storage of two 1000ltr IBCs or up to eight 205ltr drums
- Strong polyethylene rotationally moulded design ensures that there is no distortion of the side walls when under load



Single
SWL 2000kg



Double
SWL 4000kg

Product Number	Size	Dimensions (cm)	Sump (ltr)	Order Code SOL-741	Price/1 TB
SSP110	Single	200 x 149 x 76	1100	-6240S	72100.00
SSP114	Double	245 x 145 x 57	1100	-6250T	108150.00

All Weather IBC Spill Pallets

A spill pallet full of rain water does not offer much protection should a drum leak. Where IBCs are not kept under a shelter, make use of this unique design.

- Heavy duty vinyl tarp cover
- Protects against weather and foliage debris



NEW

Single
SWL 1500kg



Double
SWL 2500kg

Product Number	Size	Dimensions (cm)	Sump (ltr)	Order Code SOL-741	Price/1 TB
CDIBC-1	Single	126 x 135 x 241	1140	-2340D	169950.00
CDIBC-2	Double	256 x 135 x 221	1140	-2350E	200850.00

PRODUCTS ARE ONLY AVAILABLE VIA YOUR DISTRIBUTOR

SITE MAINTENANCE

SOLENT SPILL CONTROL Drum Trolley

- Easy to use unit combines safe transport, storage and dispensing from drums all in one
- Any spills that occur during dispensing are safely stored in the sump
- Simple to use one person operation
- Corrosion resistant 100% polyethylene construction



Product Number	Size	Dimensions (cm)	Sump (ltr)	Order Code SOL-741	Price/1 TB
SDT-230	Single	81 x 174 x 68	250	-5500T	41320.00

Drum Funnel & Tray

Drum Funnel

- An essential item when filling either a drum or IBC, particularly with waste fluids
- Designed to ensure that there are no spills with an integral lid so that the funnel can be left in place when not in use
- Fits over the top of a 205ltr drum
- Corrosion resistant 100% polyethylene construction

Drum Tray

- Where there is only one drum in use in an area, the Oil Storage Regulations state that a drum tray with a capacity that is 25% of the size of the drum is sufficient - This circular tray meets the requirement
- Ideal as a temporary bund for smaller items during maintenance operations, including batteries
- Corrosion resistant 100% polyethylene construction



Product Number	Item	Dimensions (cm)	Sump (ltr)	Order Code SOL-741	Price/1 TB
SF-20L	Funnel	61 dia x 23	-	-5650X	6896.00
SOT-8	Tray	87 dia x 19	50	-5840T	6695.00

Drum Racker & Stacker

- For safe storage and dispensing applications put one or more of these units in place
- The base unit can be used on its own for two drums, or up to two levels of stackers can be used for a maximum storage of six drums
- Corrosion resistant 100% polyethylene construction



Product Number	Item	Dimensions (cm)	Sump (ltr)	Order Code SOL-741	Price/1 TB
SDS-B2	Drum Base	137 x 135 x 63	450	-5420B	46350.00
SDS-R2	Drum Riser	137 x 94 x 39	-	-5420R	25750.00

Salvage Container

- Where a drum is damaged or leaking, UN transport regulations require that it is transported in a leakproof container - this container fully meets these regulations
- The 100% polyethylene construction ensures compatibility to a broad band of chemicals and oils
- The lid is fully threaded and can be tightened using a bar or piece of timber across the slots
- The moulded design allows for lifting by a fork-lift or sling



Product Number	Item	Dimensions (cm)	Sump (ltr)	Order Code SOL-741	Price/1 TB
SSD-360	Salvage Drum	81 dia x 105	360	-6020B	19055.00

Absorbent Drum Pads

- Cut to fit exactly on the top of a 205ltr drum.
- Help keep a dispensing area free of leaks and drips.
- Maintenance grade absorbent material.
- Each drum pad will absorb up to 1ltr of most industrial fluids.



PACK OF 5

Product Number	Application	Absorbs Per Pad	Diameter	Pack Qty	Order Code SOL-742	Price/Pk TB
MPA5656	Maintenance	1.0 ltr	56cm	5	-0620B	1288.00

SITE MAINTENANCE

SOLENT SPILL CONTROL Bench Trays

- For use in a laboratory or other areas where small containers are in use and it is essential that any spills are contained
- Removable grate for easy cleaning



Product Number	Item	Dimensions (cm)	Sump (ltr)	Order Code SOL-741	Price/1 TB
SW-T1	Bench Tray	63 x 55 x 7	9.5	-6530T	6585.00

Drum Cupboards

- Provide a neat and tidy solution to the storage of drums and containers of various sizes up to 205ltr
- Fully weather-resistant
- With lockable doors and integral sumps
- Corrosion resistant 100% structural grade polyethylene construction
- With removable grates
- Suitable for battery storage

SSC-CAB2



SSC-CAB1



EXTENDED RANGE

SSC-CAB4



SSC-CAB5



Product Number	No. of Grates	Dimensions (cm)	Sump (ltr)	Order Code SOL-741	Price/1 TB
SSC-CAB1	3	55 x 44 x 99	30	-6110H	26780.00
SSC-CAB2	3	65 x 57 x 165	70	-6120J	46350.00
SSC-CAB5	2	72 x 92 x 152	100	-6150M	77250.00
SSC-CAB4	1	72 x 92 x 184	250	-6140L	72100.00

Drum Trays

- Suitable for the safe storage of 20ltr drums, fluid measures and other common workshop items
- Highly durable construction
- Fully nestable (without grates)

“Stand-On” Trays

- With removable grates. Unique non-slip texture



Product Number	Size	Dimensions (cm)	Sump (ltr)	Order Code SOL-741	Price/1 TB
SGST-20	Small	60 x 40 x 15	20	-5680M	6179.00
SGST-30	Medium	80 x 40 x 15	30	-5681N	7209.00
SGST-40	Large	80 X 60 x 15	40	-5682P	9269.00

“Stand-In” Trays

- Without grate



Product Number	Size	Dimensions (cm)	Sump (ltr)	Order Code SOL-741	Price/1 TB
SGST-20	Small	60 x 40 x 15	20	-6270B	5665.00
SGST-30	Medium	80 x 40 x 15	30	-6271C	6695.00
SGST-40	Large	80 X 60 x 15	40	-6273D	7725.00

Small Container Trays

- Small drums are just as likely to leak or spill as large ones
- Three different sizes cope with drums up to 25ltr
- Corrosion resistant 100% polyethylene construction
- With removable grates



Product Number	Size	Dimensions (cm)	Sump (ltr)	Order Code SOL-741	Price/1 TB
SWB1	1 Drum	55 x 55 x 11	27.5	-6810A	8755.00
SWB2	2 Drum	72 x 46 x 11	27.5	-6820B	9785.00
SWB4	4 Drum	92 X 72 x 18	100	-6840D	14935.00

SITE MAINTENANCE

PRODUCTS ARE ONLY AVAILABLE VIA YOUR DISTRIBUTOR

SPILL RESPONSE

Do your employees know which absorbent grade should be used for different spills?

Maintenance

Absorbs All Fluids - Grey/Black

- General maintenance absorbents are made of pure meltblown polypropylene suitable for spills of all non-aggressive chemicals, oil and water based fluids.
- The most commonly used spill response product.
- A “must have” part of most emergency response plans.
- Ideal for use in industrial situations where many different kinds of liquids are present at the same time.
- Available in lightweight, mediumweight and heavyweight types for a wide range of response requirements.
- Maintenance absorbents are available as pads, rolls, socks, pillows and in a range of spill kits.

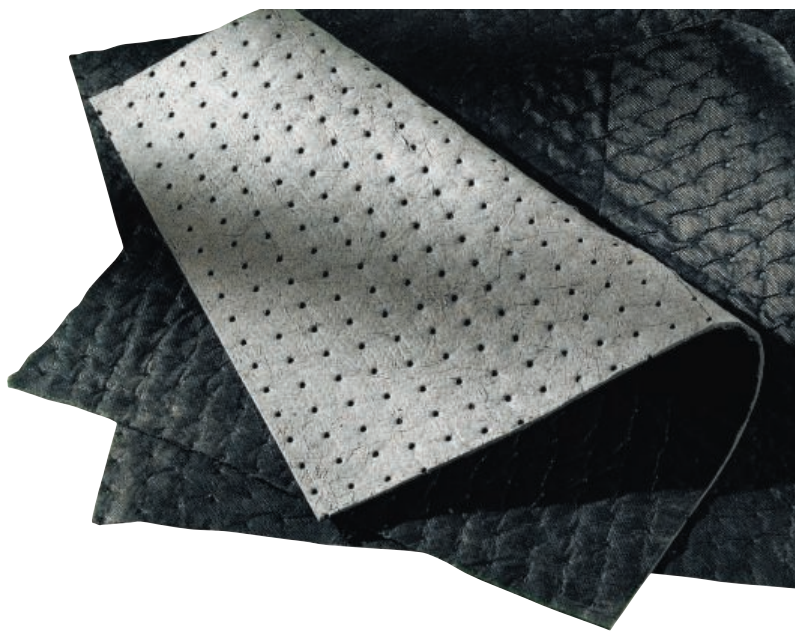

Oil-Only

Repels Water - White

- **Always white in colour for easy recognition and to alert to the start of a leak.**
- Hydrophobic - Oil-only absorbents do not absorb water making them ideal for any outdoor environment where oil is a hazard and must be removed.
- Floats on water - even when fully saturated with oil, allowing for easy pick up and disposal.
- Available in lightweight, mediumweight and heavyweight types for a wide range of response requirements.
- Oil-only absorbents are available as pads, rolls, socks, pillows and in a range of spill kits.
- Also available as booms specifically designed for use on open water.



Chemical

Also known as “Universal” - Yellow

- **Always yellow in colour for easy recognition and to alert users that once used the product must be handled in full PPE clothing and disposed of in the correct way.**
- For use with water based fluids and aggressive chemicals, oils and solvents. Not suitable for use on water.
- Can be used with aggressive chemicals such as acids, kerosene and detergents.
- Chemical absorbents are made of pure meltblown polypropylene.
- Available in lightweight, mediumweight and heavyweight types for a wide range of response requirements.
- Chemical absorbents are available as pads, rolls, socks, pillows and in a range of spill kits.



SOLENTTM SPILL CONTROL **Essential Light Weight Absorbents**

- Designed to be simple and without unnecessary frills
- Especially suited to low-volume, high-frequency use
- Ideal replacement for granules
- Lint-free
- Works with **Spill Depot** to ensure site compliance and fast access - see page **728**

Hazard level: Low to moderate

Typical spill volume: Low

Frequency of use: High

Performance and endurance combined in a lightweight design. A straight forward and highly cost effective solution to spill control.

Maintenance - Absorbs All Fluids - Grey/Black
For use with water based fluid spills and non-aggressive chemicals and oils. Not suitable for use on water.

Oil-Only - Repels Water - White
Hydrophobic absorbent can be used on water. Will float even when oil laden.

Chemical (Universal) - Yellow
For use with water based fluids and aggressive chemicals, oils and solvents. Not suitable for use on water.



SITE MAINTENANCE

"Essentials" - Light Weight Absorbent Pads

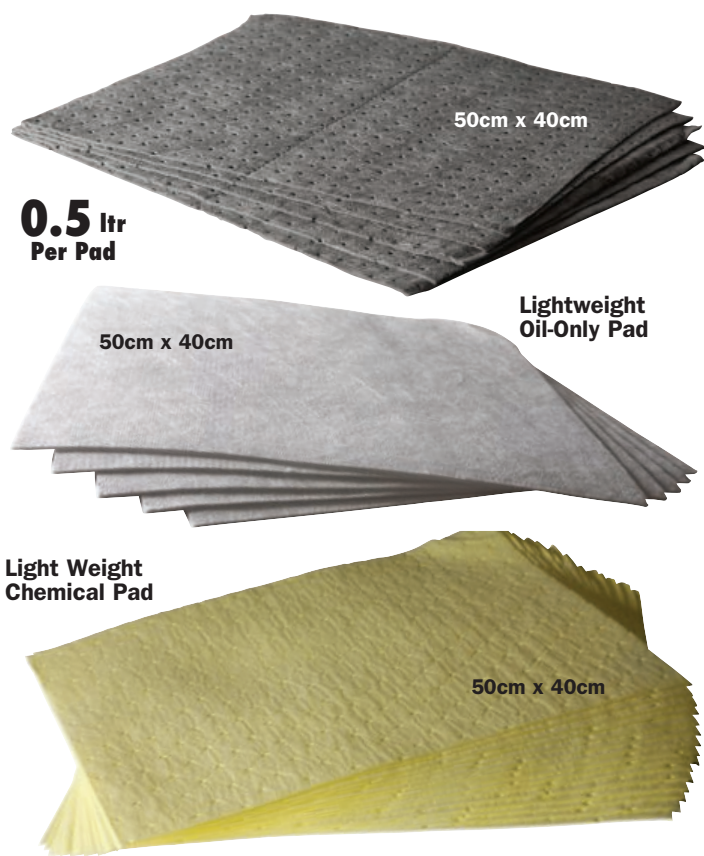

"Essentials" - Light Weight Absorbent Rolls



Product Number	Application	Absorbs Per Pad	Dimensions W x L	Pack Qty	Order Code SOL-742	Price/Pk TB
SMP501	Maintenance	0.5 ltr	50cm x 40cm	50	-2850J	1942.00
SMP504	Maintenance	0.5 ltr	50cm x 40cm	200	-2860K	5850.00
SMP501	Oil-Only	0.5 ltr	50cm x 40cm	50	-3420H	1643.00
SMP504	Oil-Only	0.5 ltr	50cm x 40cm	200	-3360S	5511.00
SMP501	Chemical	0.5 ltr	50cm x 40cm	50	-2790D	2575.00
SMP504	Chemical	0.5 ltr	50cm x 40cm	200	-2780C	8239.00

Product Number	Application	Absorbs Per Roll	Dimensions W x L	Pack Qty	Order Code SOL-742	Price/Pk TB
EMR50	Maintenance	50 ltr	50cm x 40m	1	-0652R	3348.00
EOOR50	Oil-Only	50 ltr	50cm x 40m	1	-0658R	3089.00
ECR50	Chemical	50 ltr	50cm x 40m	1	-0644R	3605.00

PRODUCTS ARE ONLY AVAILABLE VIA YOUR DISTRIBUTOR

GROUP 742 SPILL RESPONSE

SOLENT PLUS SPILL CONTROL Plus Medium Weight Absorbents

- The mid-range, all-round choice for onsite spill management
- Medium weight design featuring single-side coverstock for added strength and tear resistance
- Low-lint release for a cleaner job
- Multiple perforations for improved productivity. Performance and endurance, combined. Legal compliance, assured
- Works with **Spill Depot** to ensure site compliance and fast access - see page **728**

Hazard level: Moderate to high
Typical spill volume: Medium
Frequency of use: Medium to high

Medium weight design with coverstock for added strength – The "Workshop Essential". A mid to high end, balanced solution. Optimised for increased absorption per-pad.

Maintenance - Absorbs All Fluids - Grey/Black
 For use with water based fluid spills and non-aggressive chemicals and oils. Not suitable for use on water.

Oil-Only - Repels Water - White
 Hydrophobic absorbent can be used on water. Will float even when oil laden.

Chemical (Universal) - Yellow
 For use with water based fluids and aggressive chemicals, oils and solvents. Not suitable for use on water.



SITE MAINTENANCE

"Solent Plus" Medium Weight Absorbent Pads

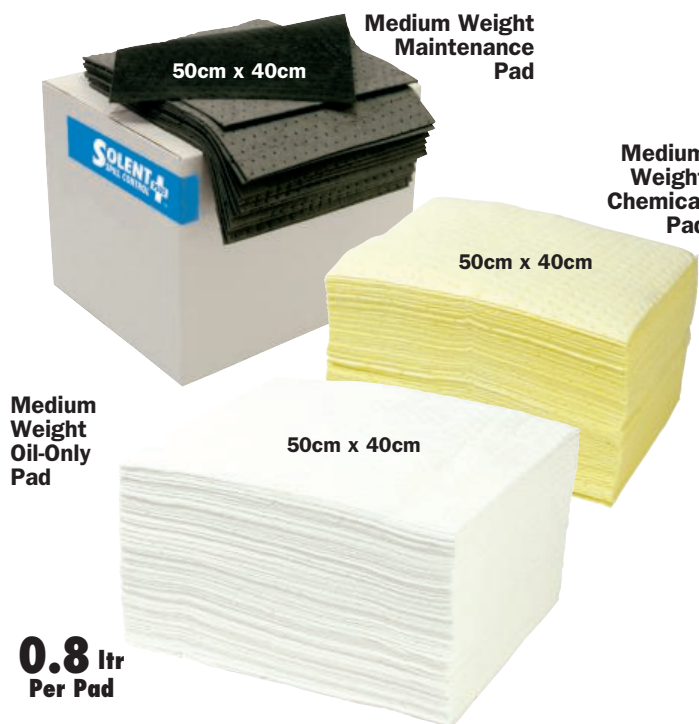

Product Number	Application	Absorbs Per Pad	Dimensions W x L	Pack Qty	Order Code SOL-742	Price/Pk TB
PMP503	Maintenance	0.8 ltr	50cm x 40cm	100	-4010J	5146.00
POP100	Oil-Only	0.8 ltr	50cm x 40cm	100	-4310R	4775.00
PCP504	Chemical	0.8 ltr	50cm x 40cm	100	-4610A	5438.00

"Solent Plus" Medium Weight Absorbent Rolls

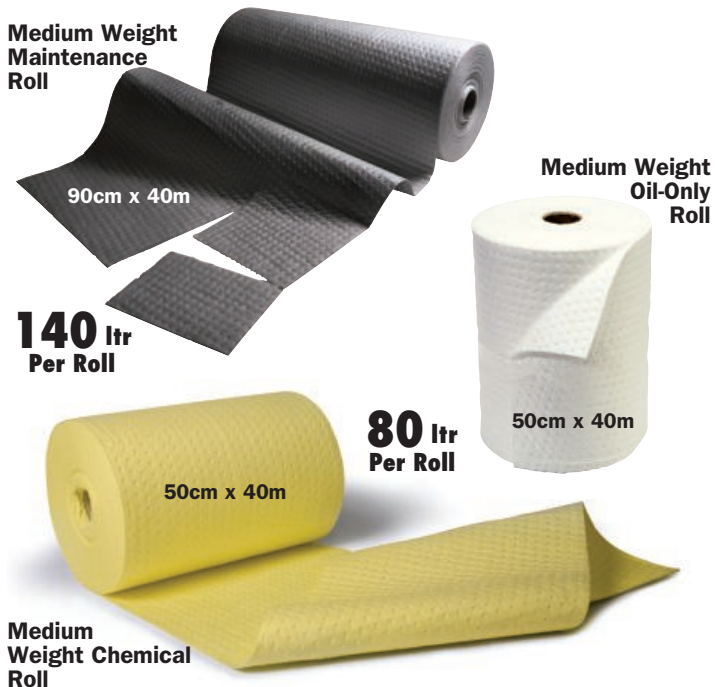

Product Number	Application	Absorbs Per Roll	Dimensions W x L	Pack Qty	Order Code SOL-742	Price/Pk TB
SMP501	Maintenance	80 ltr	50cm x 40m	1	-4100C	5571.00
SMP504		140 ltr	90cm x 40m	1	-4110L	10079.00
SMP501	Oil-Only	80 ltr	50cm x 40m	1	-4400T	4668.00
SMP504		140 ltr	90cm x 40m	1	-4410V	9018.00
SMP501	Chemical	80 ltr	50cm x 40m	1	-4700C	4775.00
SMP504		140 ltr	90cm x 40m	1	-4710D	8753.00



SITE MAINTENANCE



"Solent Plus" Absorbent Pillows

Maintenance Pillow



Oil-Only Pillow



3.5 ltr Per Pillow



Chemical Pillow

Product Number	Application	Absorbs Per Pillow	Dimensions W x L	Pack Qty	Order Code SOL-742	Price/Pk TB
SMC303	Maintenance	3.5 ltr	28cm x 38cm	16	-2610F	5149.00
SOC303	Oil-Only	3.5 ltr	28cm x 38cm	16	-2620G	5149.00
SCC303	Chemical	3.5 ltr	28cm x 38cm	16	-2600E	14935.00

"Solent Plus" Absorbent Booms



12cm x 3.0m

Oil-Only Boom

30 ltr Per Boom



20cm x 3.0m

80 ltr Per Boom

Can be connected to each other to create longer spans

Product Number	Application	Absorbs Per Boom	Dimensions W x L	Pack Qty	Order Code SOL-742	Price/Pk TB
SB0123	Oil-Only	30 ltr	12cm x 3.0m	4	-0820J	7725.00
SB0203	Oil-Only	80 ltr	20cm x 3.0m	4	-0840L	11140.00

"Solent Plus" Absorbent Socks

Maintenance Sock



5 ltr Per Sock

7.5cm x 1.2m



12.5 ltr Per Sock

7.5cm x 3.0m

Oil-Only Sock

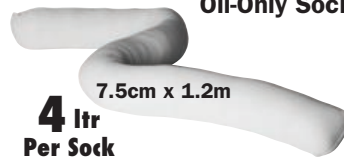

4 ltr Per Sock

7.5cm x 1.2m



7.5cm x 3.0m

10 ltr Per Sock

Chemical Sock



4 ltr Per Sock

7.5cm x 1.2m



7.5cm x 3.0m

10 ltr Per Sock

Product Number	Application	Absorbs Per Sock	Dimensions W x L	Pack Qty	Order Code SOL-742	Price/Pk TB
PMS812	Maintenance	5 ltr	7.5cm x 1.2m	20	-4170N	5438.00
PMS830		12.5 ltr	7.5cm x 3.0m	8	-4180P	5040.00
POS812	Oil-Only	4 ltr	7.5cm x 1.2m	20	-4470X	5438.00
POS830		10 ltr	7.5cm x 3.0m	8	-4480Z	5438.00
PCS812	Chemical	4 ltr	7.5cm x 1.2m	20	-4770H	6101.00
PCS830		10 ltr	7.5cm x 3.0m	8	-4780K	6101.00

PRODUCTS ARE ONLY AVAILABLE VIA YOUR DISTRIBUTOR

GROUP 742 SPILL RESPONSE

SOLENT™ SPILL CONTROL Prime Heavy Weight Absorbents

- Heavyweight design - 25% more absorption than Solent Plus
- A heavyweight design featuring a coverstock, the 25% increase in loft provides improvement in absorbent capacity from 0.8 litres to 1.0 litre per pad
- Works with **Spill Depot** to ensure site compliance and fast access - See page **728**

Hazard level: High
Typical spill volume: High
Frequency of use: Low to medium



"Solent Prime" Heavy Weight Absorbent Pads



Product Number	Application	Absorbs Per Roll	Dimensions W x L	Pack Qty	Order Code SOL-742	Price/Pk TB
PPMP1	Maintenance	1.0 ltr	50cm x 40cm	100	-3852B	4363.00
SPOP1	Oil-Only	1.0 ltr	50cm x 40cm	100	-3862B	4193.00
SPCP1	Chemical	1.0 ltr	50cm x 40cm	100	-3842B	4929.00

Enhanced performance-per-pad - optimised for higher capacity and quicker wicking. Do more, with less product and lower overall cost.

Maintenance - Absorbs All Fluids - Grey/Black
 For use with water based fluid spills and non-aggressive chemicals and oils. Not suitable for use on water.

Oil-Only - Repels Water - White
 Hydrophobic absorbent can be used on water. Will float even when oil laden.

Chemical (Universal) - Yellow
 For use with water based fluids and aggressive chemicals, oils and solvents. Not suitable for use on water.

"Solent Prime" Heavy Weight Absorbent Rolls



Product Number	Application	Absorbs Per Roll	Dimensions W x L	Pack Qty	Order Code SOL-742	Price/Pk TB
SPMR100	Maintenance	100 ltr	50cm x 40m	1	-3854D	4363.00
SPMR180		180 ltr	90cm x 40m	1	-3856F	8956.00
SPOR100	Oil-Only	100 ltr	50cm x 40m	1	-3864D	4193.00
SPOR180		180 ltr	90cm x 40m	1	-3866F	8328.00
SPCR100	Chemical	100 ltr	50cm x 40m	1	-3844D	4929.00
SPCR180		180 ltr	90cm x 40m	1	-3846F	10146.00

"Solent Prime" Heavy Weight Absorbent Rolls

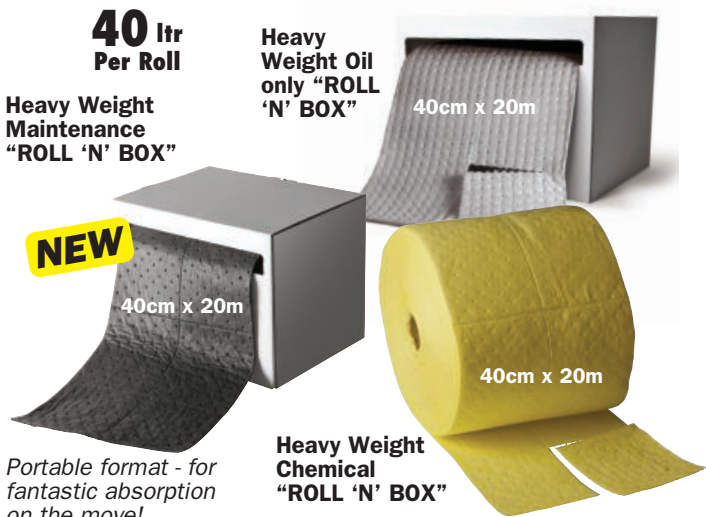

Portable format - for fantastic absorption on the move!

Product Number	Application	Absorbs Per Roll	Dimensions W x L	Pack Qty	Order Code SOL-742	Price/Pk TB
SMR40	Maintenance	40 ltr	40cm x 20m	1	-2875M	3089.00
SOOR40	Oil-Only	40 ltr	40cm x 20m	1	-3220M	3089.00
SCR40	Chemical	40 ltr	40cm x 20m	1	-1260M	3605.00

SITE MAINTENANCE



Sustainably Sourced - Ultra-Absorbent

New Improved!

- Solent's Highest Performing Absorbent - absorbency rates "better than or equal to" other absorbents - **at no extra cost**
- A new generation of sustainably-sourced 'Eco-Fibre' absorbents utilising the latest **Nu-Dri™ Technology**
- Third generation coverstock supplies strength and wiping efficiency
- **Solent ULTRA** represent a new generation of sustainably sourced products



Unleashing the Absorbent Power of Natural Fibres

Hazard level: Moderate to high
Typical spill volume: Medium
Frequency of use: Medium to high

Nu-Dri is a trademark of Lubetech Industries



A new generation of sustainably-sourced 'Eco-Fibre' absorbents. Utilising naturally-occurring cottons and wood cellulose from managed forests. Third generation coverstock supplies strength and wiping efficiency.

- **Maintenance Grade** - Utilising wood cellulose from managed forests. For general uses. With the versatility to absorb a wide range of fluids including both water and oils at the same time.
- **Oil Only Grade** - Proprietary processed natural cotton specially adapted to absorb oil spill from both land and water. With a proprietary hydrophobic treatment:- absorbs oil only, rejects water and retains buoyancy even when laden.

Maintenance - Absorbs All Fluids - Grey/Black
 For use with water based fluid spills and non-aggressive chemicals and oils. Not suitable for use on water.

Oil-Only - Repels Water - White
 Hydrophobic absorbent can be used on water. Will float even when oil laden.

ULTRA Absorbent Socks

New Improved!

ULTRA Maintenance Sock



4.0 ltr Per Sock



ULTRA Oil-Only Sock

Product Number	Application	Absorbs Per Sock	Dimensions W x L	Pack Qty	Order Code SOL-742	Price/Pk TB
SUMS4	Maintenance	4.0 ltr	7.5cm x 1.2m	20	-4530M	5149.00
SUOS4	Oil Only	4.0 ltr	7.5cm x 1.2m	20	-4570R	5149.00

SITE MAINTENANCE

ULTRA Absorbent Pads

New Improved!



ULTRA Maintenance Pad

0.8 ltr Per Pad

48cm x 38cm

ULTRA Oil-Only Pad

1.4 ltr Per Pad



ULTRA Absorbent Rolls

New Improved!

ULTRA Maintenance Roll

62 ltr Per Roll

37cm x 38m

EXTENDED RANGE



ULTRA Oil-Only Roll

90 ltr Per Roll



Product Number	Application	Absorbs Per Pad	Dimensions W x L	Pack Qty	Order Code SOL-742	Price/Pk TB
SUMP1	Maintenance	0.8 ltr	48cm x 38cm	100	-4510K	4775.00
SUOP1	Oil-Only	1.4 ltr	48cm x 38cm	100	-4550P	5149.00

Product Number	Application	Absorbs Per Roll	Dimensions W x L	Pack Qty	Order Code SOL-742	Price/Pk TB
SUMR90	Maintenance	62 ltr	37cm x 38m	1	-4520L	4510.00
SUOR90	Oil-Only	90 ltr	37cm x 38m	1	-4560Q	5149.00

PRODUCTS ARE ONLY AVAILABLE VIA YOUR DISTRIBUTOR

GROUP 742 SPILL RESPONSE

SOLENT™ SPILL CONTROL Kits

Many situations require a permanent supply of absorbents to be on hand. Solent Plus™ spill kits are a cost-effective answer to this requirement. Available in Maintenance, Oil-only and Chemical kits, they range in capacity from 10ltr up to 240ltr. They are packed with sufficient absorbents to cope with a spill up to the size shown.

10 ltr Kits - In Holdalls

For quick response to smaller spills.

Kits contain:

- 10 x Solent Prime Pads (1 ltr/pad)
- 1 x Solent Plus 1.2m sock (4 ltr/sock)
- 1 x 1kg Putty Seal pre-mixed drum plug mix (SOL-741-2880R)
- 2 x Disposal bags and ties (LUT-741-6430D)



Product Number	Nominal Capacity	Supplied In	Application	Order Code SOL-742	Price/Pk TB
PMK010B	10 ltr	Holdall	Maintenance	-6100A	3714.00
POK010B	10 ltr	Holdall	Oil-Only	-6110B	3714.00
PCK010B	10 ltr	Holdall	Chemical	-6120C	4775.00

15 ltr Kits - In Carriers

Kits contain:

- 12 x Solent Prime pads (1 ltr/pad)
- 1 x Solent Plus 1.2m sock (4 ltr/sock)
- 1 x Disposal bag and tie (LUT-741-6430D)



Product Number	Nominal Capacity	Supplied In	Application	Order Code SOL-742	Price/Pk TB
PMK015B	15 ltr	Carrier	Maintenance	-6130M	1539.00
POK015B	15 ltr	Carrier	Oil-Only	-6135N	1539.00
PCK015B	15 ltr	Carrier	Chemical	-6140P	1539.00

20 ltr Kits - In Holdalls

Kits contain:

- 15 x Solent Prime pads (1 ltr/pad)
- 2 x Solent Plus 1.2m sock (4 ltr/sock)
- 2 x Disposal bags and ties (LUT-741-6430D)



Product Number	Nominal Capacity	Supplied In	Application	Order Code SOL-742	Price/Pk TB
PMK020C	20 ltr	Holdall	Maintenance	-6150D	3820.00
POK020C	20 ltr	Holdall	Oil-Only	-6160E	3820.00
PCK020C	20 ltr	Holdall	Chemical	-6170F	4510.00

Maintenance - Absorbs All Fluids - Grey/Black
For use with water based fluid spills and non-aggressive chemicals and oils. Not suitable for use on water.

Oil-Only - Repels Water - White
Hydrophobic absorbent can be used on water. Will float even when oil laden.

Chemical (Universal) - Yellow
For use with water based fluids and aggressive chemicals, oils and solvents. Not suitable for use on water.

25 ltr Kits - In Small Bins

Kits contain:

- 17 x Solent Prime pads (1.0 ltr/pad)
- 1 x Solent Plus 1.2m sock (4 ltr/sock)
- 2 x Solent Plus pillows (3.5 ltr/pillow)
- 4 x Disposal bags and ties (LUT-741-6430D)



Product Number	Nominal Capacity	Supplied In	Application	Order Code SOL-742	Price/Pk TB
PMK025A	25 ltr	Small Bin	Maintenance	-6300A	5252.00
POK025A	25 ltr	Small Bin	Oil-Only	-6310B	4616.00
PCK025A	25 ltr	Small Bin	Chemical	-6320C	5995.00

35 ltr Kits in Cube Bag

Kits contain:

- 15 x Solent Prime pads (1.0 ltr/pad)
- 2 x Solent Plus 3.0m sock (10 ltr/sock)
- 1 x Disposal bag and tie (LUT-741-6430)
- 1 x Instruction sheet



Product Number	Nominal Capacity	Supplied In	Application	Order Code SOL-742	Price/Pk TB
SMK35Y	35 ltr	Cube Bag	Maintenance	-5150S	5304.00
SOK35Y	35 ltr	Cube Bag	Oil-Only	-5160T	4613.00
SCK035Y	35 ltr	Cube Bag	Chemical	-5170V	4613.00

Personal Protective Equipment (PPE)

Because the PPE requirements of handling liquids varies in accordance with the specific liquids being used, it is assumed that suitable PPE will already be available on site and PPE is not supplied with these kits as standard. If you require any further assistance with obtaining PPE supplies please contact your local branch or representative - or ask for our Industrial Supplies Catalogue.



SITE MAINTENANCE

SOLENTTM SPILL CONTROL Kits

50 ltr Kits - In Holdalls



Kits contain:

- 35 x Solent Prime pads (1.0 ltr/pad)
- 3 x Solent Plus 1.2m sock (4 ltr/sock)
- 3 x Solent Plus pillows (3.5 ltr/pillow)
- 5 x Disposal bags and ties (LUT-741-6430D)



EXTENDED RANGE

Kits - Complete with holdall

Product Number	Nominal Capacity	Supplied In	Application	Order Code SOL-742	Price/Pk TB
PMK050S	50 ltr	Holdall	Maintenance	-6200G	7693.00
POK050S	50 ltr	Holdall	Oil-Only	-6210H	7693.00
PCK050S	50 ltr	Holdall	Chemical	-6220J	9018.00

Refills - Absorbents and bags only, as listed above

Product Number	Nominal Capacity	Supplied In	Application	Order Code SOL-742	Price/Pk TB
PMKR050S	50 ltr	-	Maintenance	-6201H	5665.00
POKR050S	50 ltr	-	Oil-Only	-6211J	4635.00
PCKR050S	50 ltr	-	Chemical	-6221K	4635.00

120 ltr Kits - In Wheeled Bins



Kits contain:

- 75 x Solent Prime pads (1.0 ltr/pad)
- 9 x Solent Plus 1.2m sock (4 ltr/sock)
- 8 x Solent Plus pillows (3.5 ltr/pillow)
- 10 x Disposal bags and ties (LUT-741-6430D)



EXTENDED RANGE

Kits - Complete with wheeled bin

Product Number	Nominal Capacity	Supplied In	Application	Order Code SOL-742	Price/Pk TB
PMK120B	120 ltr	Wheeled Bin	Maintenance	-6350D	16710.00
POK120B	120 ltr	Wheeled Bin	Oil-Only	-6360E	16710.00
PCK120B	120 ltr	Wheeled Bin	Chemical	-6370F	22279.00

Refills - Absorbents and bags only, as listed above

Product Number	Nominal Capacity	Supplied In	Application	Order Code SOL-742	Price/Pk TB
PMKR120B	120 ltr	-	Maintenance	-6351E	8755.00
POKR120B	120 ltr	-	Oil-Only	-6361F	8755.00
PCKR120B	120 ltr	-	Chemical	-6371F	12875.00

240 ltr Kits - In Wheeled Bins



Kits contain:

- 200 x Solent Prime pads (1.0 ltr/pad)
- 12 x Solent Plus 1.2m sock (4 ltr/sock)
- 10 x Solent Plus pillows (3.5 ltr/pillow)
- 18 x Disposal bags and ties (LUT-741-6430D)



EXTENDED RANGE

Kits - Complete with wheeled bin

Product Number	Nominal Capacity	Supplied In	Application	Order Code SOL-742	Price/Pk TB
PMK240B	240 ltr	Wheeled Bin	Maintenance	-6400G	30767.00
POK240B	240 ltr	Wheeled Bin	Oil-Only	-6410H	30767.00
PCK240B	240 ltr	Wheeled Bin	Chemical	-6420J	39254.00

Refills - Absorbents and bags only, as listed above

Product Number	Nominal Capacity	Supplied In	Application	Order Code SOL-742	Price/Pk TB
PMKR240B	240 ltr	-	Maintenance	-6401H	21630.00
POKR240B	240 ltr	-	Oil-Only	-6411J	18025.00
PCKR240B	240 ltr	-	Chemical	-6421K	22660.00

Spill Kit Audit Covers

Yellow, weatherproof PVC covers with elasticated cord to allow fitting over the top of a 2-wheeled wheelie bin spill kit. A4 sized clear pouch for inserting audit record sheet. Tamperproof tape fitted on the container and cover indicates whether any of the contents have been used. Depleted spill kits are classified as **ISO 14001 non-conformity**. Available in sizes to fit wheelie bins of capacities: 120 and 240ltr.



Product Number	To Fit 2 Wheeled Bin Size	Order Code SOL-742	Price/1 TB
AVC 120	120ltr	-5440V	2653.00
AVC 240	240ltr	-5540V	2678.00

SITE MAINTENANCE

GROUP 742 SPILL RESPONSE

SOLENT SPILL CONTROL SPILL DEPOT

Engineered Dispensing Solution

- Avoids the need to use stock from spill kits (designed for emergencies) to satisfy everyday requirements
- Versatile modular system - optional lockable cabinet
- Spindle location can be adjusted to suit varying roll sizes

EXTENDED RANGE

Engineered to provide compliance in a variety of locations, wherever spill response is required, providing an effective dispensing solution for pads and rolls.

- Can be free-standing or wall mounted
- Powder-coated steel construction
- Can also be used with 20 litre spill Tray

SITE MAINTENANCE



Spill Depot

Product Number	Configuration	Dimensions W x D x H	Order Code SOL-742	Price/Pk TB
MSD41	1 Bay	60 x 45 x 60cm	-8329G	9018.00
MSD42	2 Bays	60 x 45 x 127cm	-8330H	30236.00
MSD43	3 Bays	60 x 45 x 187cm	-8331J	39784.00
MSD44	1 Bay + Cabinet	60 x 45 x 127cm	-8310K	22145.00
MSD45	2 Bays + Cabinet	60 x 45 x 187cm	-8332K	49332.00



Optional Drip Tray
Fits into bottom of cabinet.

Pads and rolls supplied separately

Optional Drip Tray

Product Number	Fluid Capacity	Dimensions W x D x H	Order Code SOL-741	Price/Pk TB
SGST-20	20 ltr	60 x 40 x 15cm	-5680M	6179.00

SOLENT SPILL CONTROL Spill Barrow

- This superb product is a 'must-have' where granular absorbents are used
- The 60ltr front hopper is fitted with a lid and can be used for granular absorbents, salt or grit
- The 100ltr rear bin is designed to take a waste bag for collecting used product
- Front mounted castors for easy manoeuvring
- Manufactured from 100% polyethylene



NEW

Product Number	Dimensions	Order Code SOL-741	Price/pk TB
SSB135	136cm x 71cm x 96.5cm	-6000Z	49000.00

Clay Absorbent Granules

- Industrial general purpose granules made from a naturally occurring mineral, Attapulgite, which can be used for absorbing most fluids including water, oil and fuels
- Industry's most widely used granule type
- Non-toxic, chemically inert and fire retardant **BS 476 Part 7, Class 1** rated
- Quick and easy to use
- Excellent absorbency performance - up to 12 litres per bag



Product Number	Granule Type	Pack Size	Absorbs Per Bag	Order Code SOL-742	Price/1 TB
SCG025	Clay	20 ltr	12 ltr	-8250A	593.00



Polyurethane Drain Covers

EXTENDED RANGE

- Constructed from dual hardness laminated polyurethane with no fillers. High tack surface creates a tough, durable seal
- Low weight, easy to handle and can be used quickly for emergency spills
- Designed to be re-used - can be cleaned using soap and water and re-stored using the film cover
- Chemically resistant - can be used with a wide range of oils, fuels, solvents and other chemicals
- Environmentally safe
- Storage holdalls are also available separately, see below



Product Number	Material	Dimensions	Colour	Order Code SOL-741	Price/1 TB
SDC464P	Polyurethane	46cm x 46cm	Yellow	-3026A	9018.00
SDC616P	Polyurethane	61cm x 61cm	Yellow	-3030D	20821.00
SDCSB61	SDC616P complete with Storage Bag			-3240K	16995.00
SDC919P	Polyurethane	91cm x 91cm	Yellow	-3050F	29870.00
SDCSB91	SDC919P complete with Storage Bag			-3248M	31930.00

Translucent Drain Covers

- Translucent polymer construction enables site managers and safety officers to quickly confirm that waste water systems are free of oils, chemicals and other spilt contaminants
- Re-usable - designed for multiple applications
- With lapped reinforced edges

EXTENDED RANGE



Product Number	Material	Dimensions	Colour	Order Code SOL-741	Price/1 TB
SDC616C	Polyurethane	61cm x 61cm	Clear	-3039C	14935.00
TSDCSB61	SDC616C complete with Storage Bag			-3755D	18025.00

Reinforced Polyurethane Drain Covers

Lapped reinforced edges. Suitable for use in high traffic areas, can be driven over.



Product Number	Material	Dimensions	Colour	Order Code SOL-741	Price/1 TB
SRDC61	Polyurethane	61cm x 61cm	Clear	-3450M	21630.00
SRDCSB61	SRDC61 complete with Storage Bag			-3482K	23690.00

Your first line of defence against environmental contamination. Re-usable polyurethane or single use clay covers which are extremely malleable for use on uneven surfaces.

Single-Use Clay Drain Covers

- Made from chemically inert clay, that will not react to or with any chemical
- Extremely malleable for use on an uneven surface - will mould itself to the ground
- Hessian netting runs through the product to afford maximum strength - Supplied poly wrapped to enhance the storage life
- Can be carried on vehicles as part of an ADR kit
- For single-use only
- **Pack of 2**



Product Number	Material	Dimensions	Colour	Order Code SOL-741	Price/1 TB
SDC614	Bentonite	65cm x 65cm	Grey	-3020C	13527.00

Drum Plug (Leak Block)

- Made from chemically inert bentonite clay that forms a barrier to aqueous liquids
- Provides temporary plugging of holes in drums or pipes
- Pre-mixed ready to use putty - No surface preparation is required
- Ideal for rapid response to unexpected releases of liquid
- High tack putty applies directly onto drum or tank to form a liquid-tight seal
- For fuel and chemical leaks
- Non-toxic, non-flammable



Product Number	Material	Tub Size	Colour	Order Code SOL-741	Price/1 TB
Drum-Plug	Bentonite	1 kg	Grey	-2880R	1029.00

Drain Cover Storage Bags

- For use with all polyurethane drain covers, can also be used to hold 1kg tubs of Drum Plug premixed clay putty
- Heavy duty vinyl construction

NEW



Product Number	To Suit Drain Cover Size	Holdall Dimensions	Order Code SOL-741	Price/1 TB
SVH-70	46cm/61cm	15.5cm dia. x 70cm	-6340M	3605.00
SVH-100	91cm	15.5cm dia. x 100cm	-6340P	6695.00

PRODUCTS ARE ONLY AVAILABLE VIA YOUR DISTRIBUTOR

SITE MAINTENANCE

GROUP 904 BATTERIES

BATTERY SIZE CONVERSIONS

Size	Equivalent To	Volts
AAA	MN2400/LR03/R03U	1.5
AA	MN1500/LR6/HP7/R6U	1.5
C	MN1400/LR14/HP11/R14U	1.5
D	MN1300/LR20/HP2/R20U	1.5
9V	MN1604/6F22(U)/6LR61/PP3	9.0
996	PJ996/4R25(R)	6.0
1289	B1289/3R12	4.5
REMOTE	MN9100/LR1	1.5

EDISON Lithium Coin Battery

These lithium coin batteries are commonly used in car security (alarm/key fobs), organizer back-up batteries for PDA such as Pison etc., glucometers, cameras, electric thermometers, calculators, computer equipment (memory back-up battery), toys, accutron, communication equipment, watches, clocks, car radios, video camera data packs. They are the same size and replace the following batteries: DL2032, E-CR2032 and SB-T51.



Battery Size	Volt	Pack Quantity	Order Code EDI-904	Price/1 TB
CR2032	3V	1	-3240K	154.00

Silver Oxide Button Battery

These popular silver oxide batteries are commonly used in watches, calculators, toys and small electrical equipment. With exactly the same dimensions, they can replace: D303, D357, Gs13, 228, 357, 280-62, J, SB-B9, SR1154, SR44, SR44W, SR44H, 541, SP357, V357, 4276, KST6, 280-8, SR76E and 1131S0 batteries.

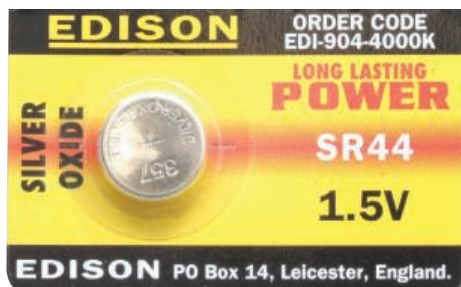

Battery Size	Volt	Pack Quantity	Order Code EDI-904	Price/1 TB
SR44	1.5V	1	-4000K	187.00

Alkaline Batteries

A range of alkaline batteries that offer significantly longer life than zinc carbon batteries in high-drain appliances. Suitable for torches, radios, answerphones, toys, calculators, pagers, remote controls, smoke alarms and many other portable electrical appliances.

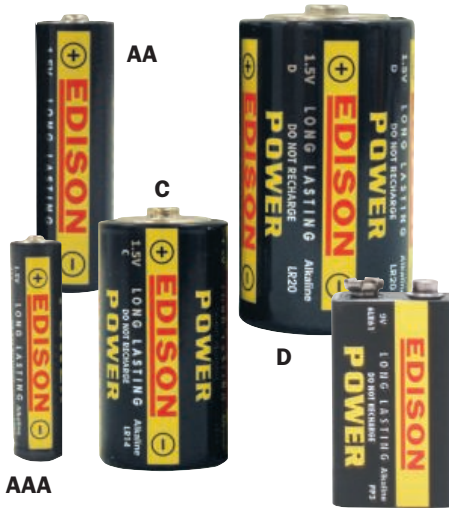

ALKALINE

Battery Size	Volt	Pack Quantity	Order Code EDI-904	Price/Pk TB
AA	1.5V	4	-3020K	97.00
AAA	1.5V	4	-3040K	97.00
C	1.5V	2	-3080K	154.00
D	1.5V	2	-3100K	258.00
6LR61	9V	1	-3000K	94.00

PJ996 6V Lantern Battery

The Edison PJ996 zinc chloride battery is ideal for lanterns, torches and most traffic management lighting, i.e. road construction and maintenance.



ZINC

Battery Size	Volt	Order Code EDI-904	Price/1 TB
PJ996	6V	-3500K	170.00

Bulk Value Battery Multi Pack



Contents	Order Code EDI-904	Price/Pk TB
5 Packs AA & 2 Packs AAA	-5000K	667.00

LED Torch Battery Set

LED torches with six super bright white LEDs. 100,000 hour LED life. Never needs a replacement bulb.

Contents: One LED torch plus 4 packs of AA batteries



Casing	Length (mm)	Order Code EDI-904	Price/1 TB
Aluminium	175	-2922K	1545.00
Black	175	-2923K	1545.00

Bulbs

To suit Edison pocket mini torches and security flashlights.



Description	To Suit Torch	Pack Qty	Order Code EDI-913	Price/1 TB
Vacuum Bulb				
2.4V/0.4A dia. 5mm	EDI-904-0150K	1	-0240K	117.00
	EDI-904-0700K	1		
Quartz Halogen Bulb				
6.0V/55W	EDI-904-2000K	1	-1400K	80.00

Description	To Suit Torch	Pack Qty	Order Code EDI-913	Price/1 TB
Xenon Bulb				
2.4V/0.85	EDI-904-282/286	2	-1100K	75.00
3.6V/0.85	EDI-904-2870K	2	-1120K	75.00
4.8V/0.85		2	-1140K	75.00
Spot Clear Bulb				
12V/0.25	EDI-904-2100K	2	-2060K	91.00

Description	To Suit Torch	Pack Qty	Order Code EDI-913	Price/1 TB
Krypton Bulb				
2.4V/0.35A	EDI-904-2800K	1	-0300K	91.00
2.4V/0.4	EDI-904-0600K	1	-1600K	117.00
2.4V/0.75	235/232/	2	-0920K	27.00
3.6V/0.75	230/236	2	-0940K	27.00
3.6V/0.75 Push in	EDI-904-0300K	1	-0360K	117.00
3.6V/0.75 Screw in	EDI-904-0200K	1	-0380K	149.00
4.8V/0.75		2	-0960K	32.00
6.0V/0.75	EDI-904-0250K	1		
6.0V/0.75	EDI-904-0350K	1	-0600K	149.00
9.0V/0.75	EDI-904-0400K	1	-0900K	181.00

EDISON LED Torches

Six super bright white LEDs. 100,000 hour LED life. Battery life up to 50 hours (continuous). Precision machined high strength aluminium alloy case. Twist on/off. Corrosion-resistant anodised finish. Water and impact resistant. Complete with wrist strap. All joints sealed with 'O' rings. Engineered and superbly balanced to give many years service.



Never needs a replacement bulb

Model Number	Casing	Batteries Required	Length (mm)	Order Code EDI-904	Price/1 TB
TAL010S	Aluminium	2x AA	175	-2550K	215.00
TAL010B	Black	2x AA	175	-2560K	215.00



Aluminium Soft Grip LED Torches

Water and impact resistant anodised aluminium case with rubber grip. Ultra bright long life LEDs with optical lens to produce a clear white light. Positive push button operation. All joints sealed with 'O' rings.



Model Number	Batteries Required	Length (mm)	Order Code EDI-904	Price/1 TB
TAS03M	3x AAA	130	-2610K	717.00
TAS03S	2x AA	170	-2600K	608.00
TAS05L	2x C	180	-2620K	827.00
TAS07L	2x D	213	-2630K	1045.00



Combi Stretch Light

TCS060

6 LED stretch torch that can be used as either a torch or a lantern. Push the housing together for a focused beam of light, or stretch the torch to illuminate a wider area. Ultra bright energy-saving LEDs give a typical battery life of approximately 24 hours. Comes complete with a cord wrist strap. Requires 4x AAA batteries (not included).

Overall length: 115mm.



Pull the housing open to illuminate a wider area or push to close for a focused beam of light



Product Number	Batteries Required	Order Code EDI-904	Price/1 TB
TCS060	4x AAA	-2700K	809.00

SITE MAINTENANCE

Flexible Light

Anodised aluminium handle and head, water-resistant and shockproof. Body can be twisted in any direction. Spare bulb included.

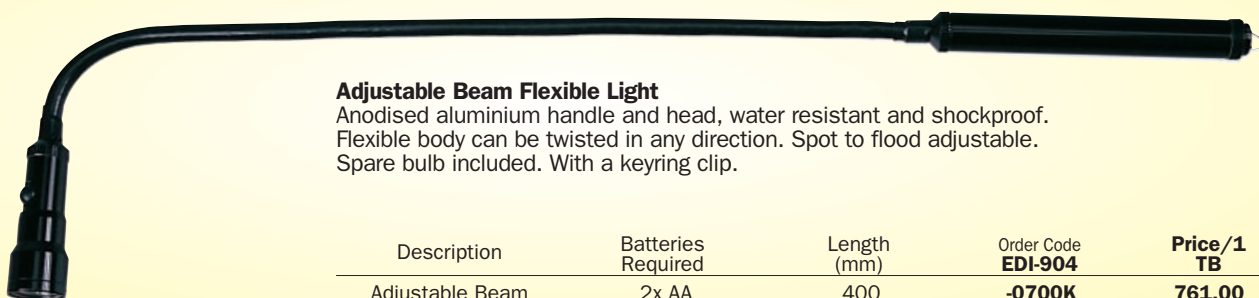

Adjustable Beam Flexible Light

Anodised aluminium handle and head, water resistant and shockproof. Flexible body can be twisted in any direction. Spot to flood adjustable. Spare bulb included. With a keyring clip.

Description	Batteries Required	Length (mm)	Order Code EDI-904	Price/1 TB
Adjustable Beam	2x AA	400	-0700K	761.00

PRODUCTS ARE ONLY AVAILABLE VIA YOUR DISTRIBUTOR

GROUP 904 TORCHES

KENNEDY 24 LED Worklight
QUALITY INDUSTRIAL TOOLING

LWL024

24 super bright LEDs. Magnetic base. Soft touch durable composite casing. 360° swivel hanging hook for hands free applications. 3 x AA batteries supplied. Lasts for 4 - 5 hours approx. IP20 moisture protection.

Length: 208mm.



Type	Weight each	Order Code	Price/1 TB
3x AA Batteries	260g	KEN-503	-5110K 384.00

30+ 7 LED Rechargeable Worklight - 230V

37 super bright LEDs. Dual use as an inspection lamp or directional torch. Moisture protection IP44. Two magnets and two 360° swivel hanging hooks for hands free applications. Lower quarter of lamp rotates 180° to use as a stand. Supplied with AC/DC mains charger and 12V DC in-car charger for portable charging. 7.2V (800mAh) Lithium-Ion battery. Main light lasts up to 4 hours, and directional light lasts up to 20hrs, when fully charged.



Voltage	Weight each	Order Code	Price/1 TB
230V	260g	KEN-503	-5100K 2733.00

EDISON Rechargeable Lamp

ILR330

30 LED rechargeable lamp.

Features:

- Oil/water resistant (IP68) heavy-duty rubber and polycarbonate case.
- Lasts up to 6 hours when fully charged.
- Adjustable brightness.
- Optional flashing mode.
- Foldaway swivel hanging hook.
- Powered by high capacity lithium-ion polymer batteries.

Comes complete with bench/wall mountable charging base.



Rated to IP68

Length	Order Code	Price/1 TB
330mm	EDI-904	-1100K 5114.00

KENNEDY LED Inspection Lamps
QUALITY INDUSTRIAL TOOLING

Durable and robust construction with a rubber handle and end cup, plus a sturdy swivel hanging hook making it ideal for use in engine bays and other low light work areas. Anti-roll hexagonal shape with a convenient grip mounted ON/OFF switch. Main light and spot light option.

Rechargeable

Main light lasts up to 3.5hrs when fully charged using the charger supplied.



Type	Order Code	Price/1 TB
Rechargeable	KEN-503	-5080K 4016.00



EDISON LED Swivel Head Torch

LSH070

Adjustable head torch with three lighting levels. Gives an ultra-bright white light provided by 7 LEDs. 5 stage tilting head. Adjustable top and side straps for total comfort and stability. Ideal torch for any low light activity.

Batteries: 3x AAA (not supplied).



Product Number	Order Code	Price/1 TB
LSH070	EDI-904	-2650K 624.00



SITE MAINTENANCE



EDISON Super Bright LED Rechargeable Spotlight

ELRS001

Weatherproof. High and standard brightness mode. SOS distress signal. Emergency light/blinking light. Two position handle, to ensure comfortable and ergonomic access. Swivel stand. Battery level indicator. 6V 4Ah sealed lead acid battery. Supplied with AC/DC mains charger and 12V DC car plug adaptor.

Battery operation times (18 hrs full charge):

- Standard brightness mode up to 8 hours.
- High brightness mode up to 3 hours.
- SOS distress mode up to 20 hours.
- Emergency light up to 25 hours.
- Emergency blinking light up to 50 hours.



247 LUMENS



Product Number	Weight	Order Code	Price/1 TB
ELRS001	1.46kg	EDI-904 -1060K	3012.00

Super Bright LED Rechargeable Spotlight

ELRW306

36 super bright LEDs. Push up telescopic design. Three light modes: 30 LED worklight - directional six LED torch - dual operation. Anti-slip rubber housing. Incorporated magnetic base. Shock, water and oil resistant. Rechargeable Li-ion battery. LED indicator and overcharge protection. Supplied with mains charger and in-car charger.

Operating times: 6 LED upto 25 hours, 30 LED up to 5 hours, 30+6 LED up to 4 hours.



NEW

80 LUMENS



Product Number	Weight	Order Code	Price/1 TB
ELRW306	530g	EDI-904 -2730K	2077.00

2.5 Million Candle Power Rechargeable Lantern

ERS002

2.5 million candle power super bright quartz halogen spotlight/lantern. Weatherproof. Two position handle, to ensure comfortable and ergonomic access. Swivel stand/handle. 6V 4Ah sealed lead acid battery. Supplied with AC/DC mains charger and 12V DC car plug adaptor for portable charging.

Battery operation time

(20 hours full charge): 20 minutes.



Product Number	Candle Power	Order Code	Price/1 TB
ERS002	2.5M	EDI-904 -1050K	2903.00



LED Rechargeable Spotlight

ELRS002

2 million candle power LED rechargeable spotlight. Super bright one watt LED light. Side LED tube light. Two position handle, to ensure comfortable and ergonomic access. Swivel handle. 6V 4Ah sealed lead acid battery. Supplied with AC/DC mains charger and 12V DC car plug adaptor for portable charging.

Battery operation times (10 hours full charge):

- Main spot light up to 6 hours.
- Side LED tube light up to 70 hours.



Product Number	Candle Power	Order Code	Price/1 TB
ELRS002	2.0M	EDI-904 -1070K	2962.00

SITE MAINTENANCE

PRODUCTS ARE ONLY AVAILABLE VIA YOUR DISTRIBUTOR

GROUP 906 HAND BRUSHES

KENNEDY Twisted Wire Tube Brushes
QUALITY INDUSTRIAL TOOLING

Twisted wire handle for hand use. For industrial maintenance, agricultural, workshop, machinery etc. For decarbonising and heavy duty cleaning use of tubes, struts, awkward places etc.



Dia. (mm)	Brush Length	Overall Length	Order Code KEN-906	Price/1 TB
Steel				
10	100mm	215mm	-1030K	126.00
15	105mm	215mm	-1050K	135.00
20	100mm	210mm	-1060K	147.00
25	100mm	215mm	-1100K	154.00
30	80mm	210mm	-1120K	174.00
Brass				
6	75mm	300mm	-1620K	187.00
10	75mm	300mm	-1630K	197.00
12	75mm	300mm	-1640K	209.00
16	75mm	300mm	-1650K	220.00
19	75mm	300mm	-1660K	220.00
25	75mm	300mm	-1700K	235.00

7 Piece Set Contents:
Tube brushes: 1x 10, 15, 20, 25 and 30mm diameter.
Nylon slimline brushes: 1x curved and 1x straight.

Number of Pieces	Weight each	Order Code KEN-906	Price/1 TB
7	200g	-9010K	1081.00

NEW Tubing Brush Plastic Handle

For manual use in cleaning tubes and removing soft deposits in condenser and heat exchanger equipment.



Dia. (mm)	Brush Length	Overall Length	Order Code KEN-906	Price/1 TB
6	30mm	170mm	-3020K	135.00
9	30mm	170mm	-3030K	145.00
12	30mm	170mm	-3040K	150.00
15	30mm	170mm	-3050K	165.00
18	30mm	170mm	-3060K	175.00
22	30mm	170mm	-3070K	185.00
25	30mm	170mm	-3080K	215.00
28	30mm	170mm	-3090K	225.00
35	30mm	170mm	-3100K	250.00

French Chalk

Square Sticks - 10 x 100mm
For general layout marking in a wide variety of applications from marking tailor's seams and weld marking on sheet materials in fabrication industries.

Flat Sticks - 5 x 12 x 125mm

Flat sticks can be used with separate holder (CTL-885-7359D).



Shape	Pack Quantity	Weight each	Order Code KEN-910	Price/Pk TB
Square	50	1.30kg	-0200K	822.00
Flat	144	3.74kg	-1000K	765.00



6mm Plain Shank
For use in power tools.

Dia. (mm)	Brush Length	Overall Length	Order Code KEN-906	Price/1 TB
Steel				
15	60mm	100mm	-1250K	151.00
20	60mm	103mm	-1260K	157.00
25	60mm	120mm	-1300K	162.00
30	60mm	115mm	-1320K	174.00
35	60mm	110mm	-1330K	185.00
Brass				
15	60mm	100mm	-1450K	174.00
20	60mm	100mm	-1460K	175.00
25	70mm	120mm	-1500K	185.00
30	65mm	120mm	-1520K	194.00
35	60mm	120mm	-1530K	234.00

10 Piece Set

Contents	Weight each	Order Code KEN-906	Price/1 TB
1 each of above	550g	-9020K	1648.00

Slimline Brushes

Plain metal handles, with steel wire or nylon bristle filling. Suitable for heavy duty cleaning and decarbonising.



Type	Head Length	Order Code KEN-906	Price/1 TB
Steel - Straight Head	50mm	-1800K	137.00
Nylon - Straight Head	50mm	-1850K	127.00
Steel - Curved Head	70mm	-1900K	179.00
Nylon - Curved Head	70mm	-1950K	147.00

Identity Discs - Numbered

Suitable for all identification uses component/batch/labelling, store/user tracking, key identification etc. 30mm outside diameter.



Type	Material	Order Code KEN-937	Price/1 TB
1 - 100 (Pack of 100)	Aluminium	-1130K	4091.00
	Brass	-2130K	5549.00

Identity Discs - Plain

Suitable for all identification uses component/batch/labelling, store/user tracking, key identification etc. 30mm outside diameter.



Type	Material	Order Code KEN-937	Price/1 TB
Plain (Single)	Aluminium	-1030K	94.00
	Brass	-2030K	117.00

COTSWOLD

Wire Scratch Brushes

A range of plastic handled scratch brushes with cast steel bristles.



*With scraper.



Number of Rows	Order Code COT-906	Price/1 TB
1	-6100K	98.00
2	-6200K	83.00
3	-6300K	94.00
4	-6400K	105.00
4*	-6450K	118.00
5	-6500K	118.00

KENNEDY Wire Scratch Brushes
QUALITY INDUSTRIAL TOOLING

Wire Scratch Brushes

Designed for cleaning all rough surfaces on a variety of materials to remove paint, dirt, rust and stubborn deposits. Hardwood stocks.

Bristle type: cast steel.
For general-purpose work.

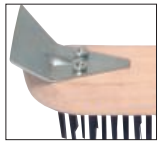

* With scraper



Number of Rows	Weight each	Order Code KEN-906	Price/1 TB
2	85g	-6200K	74.00
3	115g	-6300K	79.00
4	130g	-6400K	90.00
4*	155g	-6450K	121.00

Stainless Steel

Stainless steel wire scratch brushes are used predominantly in stainless steel welding processes, where the use of an ordinary wire scratch brush would create the risk of contamination of the weld.

Bristle type: stainless steel.



Number of Rows	Weight each	Order Code KEN-906	Price/1 TB
2	140g	-7200K	121.00
3	210g	-7300K	139.00
4	220g	-7400K	157.00

Brass

These brass wire brushes are used in situations where there could be a potential fire or explosion hazard. Brass wire brushes will not cause a spark.

Bristle type: brass.



Number of Rows	Weight each	Order Code KEN-906	Price/1 TB
2	130g	-8200K	157.00
3	220g	-8300K	218.00
4	230g	-8400K	259.00

SITE MAINTENANCE

MATLOCK Aluminium Folding Platform Steps

Made from strong lightweight aluminium with non-slip treads and platform. Available in 3 and 4 step versions and featuring safety rail. Manufactured to **EN131** and able to handle a maximum load of 150kg.

3 Tread - overall height including safety rail:
Opened: 1234mm.
Platform height: 629mm.

4 Tread - overall height including safety rail:
Opened: 1452mm.
Platform height: 847mm.

NEW



Product Number	No. of Treads	Platform Height	Order Code	Price/1 TB
MFP03	3	629mm	-5830K	3089.00
MFP04	4	847mm	-5840K	3605.00

Ratchet Cable Puller - 1300kg

Robustly constructed from galvanised steel with a powder coated body, hardened steel hooks with spring catches. It has a heavy duty swivel on the anchoring hook, 3.6m of 5mm aircraft cable giving a 1.5m pull and a sprung ratchet pawl. Suitable for pulling: trees, roots, fencing wires, vehicles, machines, boats, trailers, caravans etc.

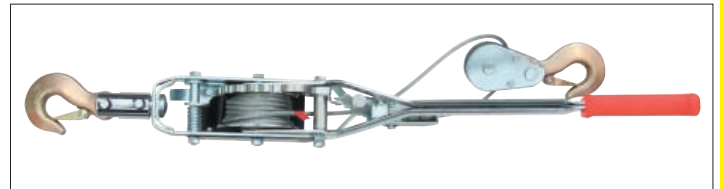
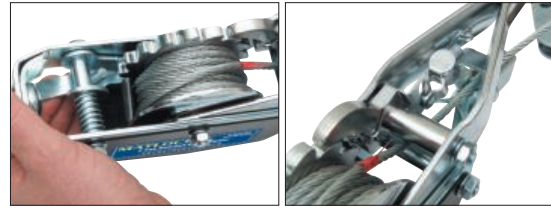

Capacity	Order Code	Price/1 TB
1300kg	-2020K	2627.00

MATLOCK Webbing Slings

High strength to weight ratio, light to handle and easy to use. Shock absorbing construction and wide load bearing area produce a secure grip and eliminate damage to the load. All types are made from oil and acid resistant polyester, treated with a wear resistant impregnation. All sizes are colour coded to indicate 'SWL' (safe working load), rating and marked with traceability code. These ratings are for a straight line pull only. Other variations of pull are shown below along with the relevant 'SWL'.

All slings come complete with test certificate.



Safe Working Loads

Straight Line	Choker	Basket	Basket 90°*	Basket 120°*
1,000kg	800kg	2,000kg	1,400kg	1,000kg
2,000kg	1,600kg	4,000kg	2,800kg	2,000kg
3,000kg	2,400kg	6,000kg	4,200kg	3,000kg
4,000kg	3,200kg	8,000kg	5,600kg	4,000kg
5,000kg	4,000kg	10,000kg	7,000kg	5,000kg

Flat Slings
 With flat metal reinforced eye at each end.
 Made to **BS 3481:2.**



Working Length (M)	Width (mm)	'SWL' (kg)	Order Code	Price/1 TB
Simplex Type - Single Thickness				
2	60	1,000	-5010K	620.00
	120	2,000	-5020K	1449.00
	180	3,000	-5030K	2230.00
3	60	1,000	-5110K	861.00
	120	2,000	-5120K	1810.00
	180	3,000	-5130K	2771.00
4	60	1,000	-5210K	1028.00
	120	2,000	-5220K	2110.00
	180	3,000	-5230K	3312.00
Duplex Type - Double Thickness				
2	30	1,000	-5510K	482.00
	60	2,000	-5520K	788.00
	90	3,000	-5530K	1119.00
	120	4,000	-5540K	1990.00
	150	5,000	-5550K	2530.00
3	30	1,000	-5610K	788.00
	60	2,000	-5620K	1149.00
	90	3,000	-5630K	1569.00
	120	4,000	-5640K	2771.00
	150	5,000	-5650K	3132.00
4	30	1,000	-5710K	1028.00
	60	2,000	-5720K	1449.00
	90	3,000	-5730K	2230.00
	120	4,000	-5740K	3853.00
	150	5,000	-5750K	4093.00
6	30	1,000	-5810K	1630.00
	60	2,000	-5820K	2110.00
	90	3,000	-5830K	3192.00
	120	4,000	-5840K	4514.00
	150	5,000	-5850K	6167.00

Endless Round Slings
 Made to **BS 6668 : Part 2.**



Working Length (M)	Width (mm)	'SWL' (kg)	Order Code	Price/1 TB
0.5	45	1,000	-1960K	337.00
	50	2,000	-1970K	475.00
	60	3,000	-1980K	603.00
1	80	5,000	-2000K	670.00
	45	1,000	-2010K	445.00
	50	2,000	-2020K	547.00
1.5	60	3,000	-2030K	698.00
	80	5,000	-2050K	914.00
	45	1,000	-2060K	831.00
2.0	50	2,000	-2070K	842.00
	60	3,000	-2080K	1058.00
	70	4,000	-2090K	1154.00
2.5	80	5,000	-2100K	1647.00
	45	1,000	-2110K	547.00
	50	2,000	-2120K	908.00
3.0	60	3,000	-2130K	1328.00
	70	4,000	-2140K	1569.00
	80	5,000	-2150K	1918.00
3.0	45	1,000	-2160K	842.00
	50	2,000	-2170K	1184.00
	60	3,000	-2180K	1689.00
3.0	70	4,000	-2190K	1930.00
	80	5,000	-2200K	2405.00
	45	1,000	-2210K	878.00
3.0	50	2,000	-2220K	1215.00
	60	3,000	-2230K	1810.00
	70	4,000	-2240K	2171.00
3.0	80	5,000	-2250K	2710.00

PRODUCTS ARE ONLY AVAILABLE VIA YOUR DISTRIBUTOR

MATLOCK

Hand Chain Hoists

Quality made 2.5m and 3m chain hoists with a capacity ranging from 500 to 3000kg. Fitted with heat treated and ground, triple-spur geared shaft and pinion. Hooks fitted with robust safety latches and 360 degree rotation. All models include mechanical load brake for extra safety.

EN 13157+A1:2009 and **EC Council Directive 2006/42/EC** Machinery compliant.



NEW

Capacity (1000kg)	0.5	1	2	3	5
Standard Lift (M)	2.5	2.5	3	3	3
Running Test Load (1000kg)	6.3	12.5	25	37.5	75
No. Columns of Load Chains	1	1	1	2	2
Load Chain Diameter (mm)	6	6	8	8	10

Capacity	Order Code MTL-941	Price/1 TB
500kg	-4200K	5099.00
1000kg	-4210K	5665.00
2000kg	-4220K	7725.00
3000kg	-4230K	10815.00
5000kg	-4240K	14678.00

Lever Hoists

750 to 3000kg range capacities. Fitted with heat treated and ground, triple-spur geared shaft and pinion. Hooks fitted with robust safety latches and rotate 360 degrees. Includes mechanical overload brake for extra safety.

EN 13157+A1:2009 and **EC Council Directive 2006/42/EC** Machinery compliant.



NEW

Capacity (1000kg)	0.75	1.5	3
Standard Lift (M)	1.5	1.5	1.5
Running Test Load (1000kg)	11.0	22.0	37.5
No. Columns of Load Chains	1	1	1
Load Chain Diameter (mm)	6	8	10

Capacity	Order Code MTL-941	Price/1 TB
750kg	-6200K	6695.00
1500kg	-6220K	7931.00
3000kg	-6250K	12309.00

Beam Clamps

1000 to 5000kg range capacities. Clamp jaw designed to reduce flange stress by distributing load away from beam edge. Easily mounted with threaded handle. Fits a wide range of flange widths and beams.

EN 13155:2003 + A2:2009 and **EC Council Directive 2006/42/EC** Machinery compliant.



NEW

Lifting Capacity	Flange Width	Order Code MTL-941	Price/1 TB
1000kg	75 - 220mm	-1010K	3089.00
2000kg	75 - 220mm	-1020K	4119.00
3000kg	80 - 320mm	-1030K	5408.00
5000kg	80 - 320mm	-1050K	5665.00

SITE MAINTENANCE

KENNEDY 1,000kg Folding Mobile Crane
QUALITY INDUSTRIAL TOOLING

Ideal for home workshops or garages. Folding design for easy storage and transportation. Flow control valve for precise lowering and positioning. Overload safety valve. Hydraulic operation providing easy lifting. Heavy duty swivel hook with safety latch. four different jib options. Heavy duty castors.



Model number	FMC001.
Order Code	KEN-941-3670K.
Lifting capacity position (a)	1,000kg.
Lifting capacity position (b)	750kg.
Lifting capacity position (c)	500kg.
Lifting capacity position (d)	250kg.
Maximum lifting height at minimum jib extension	1868mm.
Maximum lifting height at maximum jib extension	2004mm.
Length of jib in position (a)	865mm.
Length of jib in position (b)	955mm.
Length of jib in position (c)	1045mm.
Length of jib in position (d)	1135mm.
Clearance height of legs	130mm.
Length of frame	1480mm.
Overall clearance height	1555mm.
Maximum width of frame	1000mm.
Distance between rear wheel centres	640mm.
Weight	91kg.

1 tonne (metric ton or t) = 1000kg
 1 ton (imperial ton) = 2240lbs (1016kg)

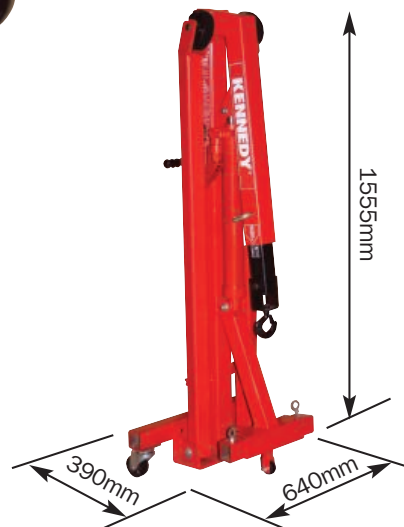
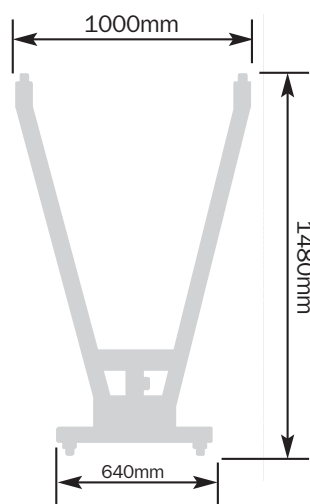
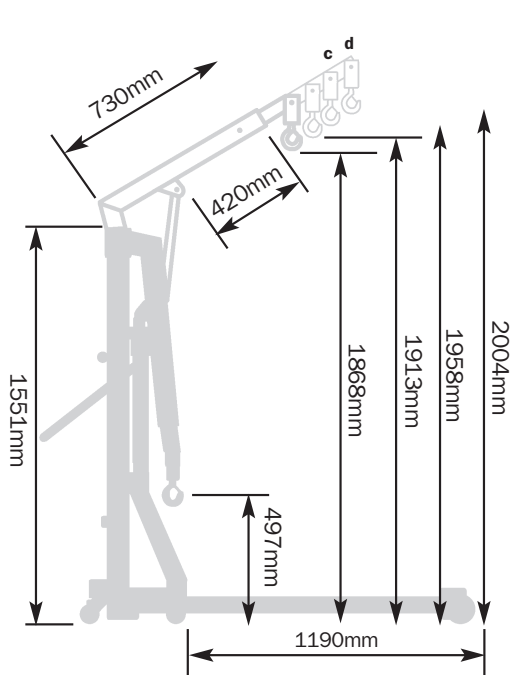

Model Number	Capacity	Max. Hook Height (mm)	Weight each	Order Code	Price/1 TB
FMC001	1,000kg	2445	91kg	KEN-941-3670K	46350.00
Spares for above			Description	Order Code	Price/1 TB
			Seal Repair Kit	-8200K	266.00
			Replacement Ram	-8800K	9785.00

SITE MAINTENANCE

ATLAS Black Rubber Tyre Plastic Centre



Suitable for use on most surfaces and for humid environments where medium harsh chemicals may be present. Quiet running with 'cushioned' tyre. Not recommended for use where mineral or organic acids are present. Operating temperature range -20°C to +60°C.

Wheel Diameter	Wheel Width*	Overall Height	Plate Size	Plate Hole Centres
80	25	108	100 x 80	80 x 60
100	30	127	100 x 80	80 x 60
125	37	155	100 x 80	80 x 60
160	40	197	120 x 106	105 x 80
200	50	240	129 x 106	105 x 80

EXTENDED RANGE

For dimensions see right.

Except for "Red Polyurethane Tyre" type castors. See detail on next page.

		Swivel-Type with Top Plate		Swivel-Type with Top Plate & Brake		Fixed-Type with Top Plate		Swivel-Type with Bolt Hole				Wheel Only	
Wheel Dia.(mm)	Load Max(kg)	Order Code ATL-945	Price/1 TB	Order Code ATL-945	Price/1 TB	Order Code ATL-945	Price/1 TB	Order Code ATL-945	Price/1 TB	Order Code ATL-945	Price/1 TB	Order Code ATL-945	Price/1 TB
80	65	-5115K	303.00	-5125K	478.00	-1170K	258.00	-5135K	314.00	-	-	-5610K	199.00
100	80	-5215K	469.00	-1180K	617.00	-1220K	308.00	-5230K	491.00	-	-	-5620K	187.00
125	110	-0930K	900.00	-5320K	917.00	-1230K	464.00	-5330K	650.00	-	-	-5630K	222.00
200	200	-1190K	670.00	-1240K	1339.00	-5500K	1518.00	-1814K	1500.00	-	-	-5650K	777.00

Black Rubber Tyre Steel Centre Wheel with Roller Bearing

For smooth running with heavier loads. Suitable for use on most surfaces and for humid environments where medium harsh chemicals may be present. Quiet running with 'cushioned' tyre. Not recommended for use where mineral or organic acids are present. Operating temperature range -20°C to +60°C.

For dimensions see top-right.

EXTENDED RANGE

		Swivel-Type with Top Plate		Swivel-Type with Top Plate & Brake		Fixed-Type with Top Plate		Swivel-Type with Bolt Hole		Swivel-Type with Bolt Hole & Brake		Wheel Only	
Wheel Dia.(mm)	Load Max(kg)	Order Code ATL-945	Price/1 TB	Order Code ATL-945	Price/1 TB	Order Code ATL-945	Price/1 TB	Order Code ATL-945	Price/1 TB	Order Code ATL-945	Price/1 TB	Order Code ATL-945	Price/1 TB
80	60	-2525K	372.00	-2545K	750.00	-1020K	411.00	-2535K	372.00	-2555K	585.00	-3210K	88.00
100	70	-2615K	492.00	-2635K	691.00	-2605K	387.00	-1110K	572.00	-1200K	823.00	-3220K	273.00
125	100	-2715K	622.00	-2735K	897.00	-1120K	593.00	-2720K	655.00	-2740K	933.00	-3230K	147.00
160	180	-2915K	1592.00	-1040K	1545.00	-1030K	979.00	-2920K	1539.00	-2940K	1964.00	-3250K	670.00
200	200	-3015K	2228.00	-3035K	2514.00	-1130K	950.00	-3020K	2228.00	-3040K	2547.00	-3260K	696.00

Grey Rubber Tyre, Plastic Centre Wheel with Plain Bore

Non-marking, quiet running 'cushioned' rubber tyre. Suitable for use on hard floors (cement, tiles, etc) and for humid environments where medium harsh chemicals may be present. Not recommended for use with organic solvents, chlorinated substances, hydrocarbons or mineral oils. Operating temperature range -20°C to +60°C.

For dimensions see top-right.

EXTENDED RANGE

		Swivel-Type with Top Plate		Swivel-Type with Top Plate & Brake		Fixed-Type with Top Plate		Swivel-Type with Bolt Hole		Swivel-Type with Bolt Hole & Brake		Wheel Only	
Wheel Dia.(mm)	Load Max(kg)	Order Code ATL-945	Price/1 TB	Order Code ATL-945	Price/1 TB	Order Code ATL-945	Price/1 TB	Order Code ATL-945	Price/1 TB	Order Code ATL-945	Price/1 TB	Order Code ATL-945	Price/1 TB
Zinc Plated													
80	60	-6020K	292.00	-5150K	420.00	-1010K	308.00	-1100K	411.00	-	-	-2410K	205.00
100	70	-2120K	464.00	-5160K	464.00	-2105K	318.00	-2140K	462.00	-2170K	690.00	-2420K	228.00
125	100	-2215K	411.00	-2245K	1009.00	-2205K	351.00	-2220K	759.00	-2250K	992.00	-2430K	284.00
Stainless Steel													
80	60	-	-	-	-	-	-	-2040K	1450.00	-	-	-2410K	205.00
100	70	-2130K	1300.00	-	-	-2110K	1200.00	-2150K	1300.00	-2180K	1600.00	-2420K	228.00
125	100	-	-	-	-	-	-	-2230K	1500.00	-2260K	1900.00	-2430K	284.00



ATLAS Nylon Wheel with Plain Bore

Suitable for use on compacted floors (cement, tiles, etc.) Particularly recommended for the food processing industry. Not recommended for use where mineral or organic acids are present. Operating temperature range -10°C to +60°C.

EXTENDED RANGE

For dimensions see previous page.

		Swivel-Type with Top Plate		Swivel-Type with Top Plate & Brake		Fixed-Type with Top Plate		Swivel-Type with Bolt Hole		Swivel-Type with Bolt Hole & Brake		Wheel Only	
Wheel Dia.(mm)	Load Max(kg)	Order Code ATL-945	Price/1 TB	Order Code ATL-945	Price/1 TB	Order Code ATL-945	Price/1 TB	Order Code ATL-945	Price/1 TB	Order Code ATL-945	Price/1 TB	Order Code ATL-945	Price/1 TB
Zinc Plated													
80	80	-7830K	346.00	-3875K	603.00	-7810K	266.00	-5170K	346.00	-3895K	585.00	-4400K	128.00
100	125	-3930K	392.00	-5180K	495.00	-3910K	315.00	-3955K	381.00	-3995K	585.00	-4410K	150.00
125	130	-4030K	511.00	-4070K	840.00	-4010K	440.00	-4050K	494.00	-1210K	599.00	-4420K	250.00
200	200	-1050K	1350.00	-1140K	1803.00	-4210K	2276.00	-4250K	1450.00	-4290K	2150.00	-4440K	599.00
Stainless Steel													
80	80	-3840K	1250.00	-	-	-3820K	1400.00	-3860K	1650.00	-3900K	1950.00	-4400K	128.00
100	125	-3940K	1500.00	-3980K	2150.00	-3920K	1300.00	-3960K	1500.00	-4000K	2100.00	-4410K	150.00
125	130	-4040K	1650.00	-4080K	1950.00	-	-	-4060K	1750.00	-4100K	1950.00	-4420K	250.00
150	180	-4140K	2750.00	-	-	-4120K	2100.00	-	-	-	-	-	-
200	200	-4240K	2950.00	-4280K	3999.00	-4220K	2750.00	-4260K	1950.00	-5430K	1029.00	-4440K	599.00

High Temperature Phenolic Resin Wheel with Plain Bore

Suitable for use on hard floors (cement, tiles, etc.) and for humid environments where medium harsh chemicals may be present. Not recommended on uneven or rough surfaces. Operating temperature range -30°C to +300°C.

For dimensions see previous page.

EXTENDED RANGE

		Swivel-Type with Top Plate		Fixed-Type with Top Plate		Swivel-Type with Bolt Hole				Wheel Only			
Wheel Dia.(mm)	Load Max(kg)	Order Code ATL-945	Price/1 TB	Order Code ATL-945	Price/1 TB	Order Code ATL-945	Price/1 TB	Order Code ATL-945	Price/1 TB	Order Code ATL-945	Price/1 TB	Order Code ATL-945	Price/1 TB
Zinc Plated													
80	100	-3530K	691.00	-	-	-3510K	585.00	-	-	-	-	-3700K	799.00
100	125	-3630K	1201.00	-	-	-3610K	797.00	-3650K	1201.00	-	-	-3710K	899.00
Stainless Steel													
80	100	-3540K	850.00	-	-	-3520K	1300.00	-3560K	1400.00	-	-	-3700K	799.00
100	125	-3640K	1400.00	-	-	-	-	-3660K	1500.00	-	-	-3710K	899.00

Red Polyurethane Tyre, Nylon Centre Wheel with Plain Bore

Suitable for use on most surfaces and for humid environments where medium harsh chemicals may be present. Quiet running with 'cushioned' tyre. Not recommended for use where mineral or organic acids are present.

Wheel widths as below, for plate height and dimensions see previous page.

EXTENDED RANGE

		Swivel-Type with Top Plate		Swivel-Type with Top Plate & Brake		Fixed-Type with Top Plate		Swivel-Type with Bolt Hole		Swivel-Type with Bolt Hole & Brake		Wheel Only	
Wheel Dia. (mm)	Wheel Width	Order Code ATL-945	Price/1 TB	Order Code ATL-945	Price/1 TB	Order Code ATL-945	Price/1 TB	Order Code ATL-945	Price/1 TB	Order Code ATL-945	Price/1 TB	Order Code ATL-945	Price/1 TB
Zinc Plated													
80	25	-8520K	387.00	-4565K	603.00	-4505K	279.00	-4545K	438.00	-1150K	399.00	-5010K	239.00
100	30	-4620K	555.00	-5190K	711.00	-4605K	355.00	-4645K	555.00	-1090K	450.00	-5020K	205.00
125	37	-4720K	1550.00	-8760K	933.00	-4705K	691.00	-1060K	550.00	-4780K	550.00	-5030K	308.00
160	40	-4925K	2812.00	-4965K	3025.00	-1070K	1500.00	-4940K	2250.00	-	-	-5050K	1803.00
200	50	-	-	-	-	-	-	-	-	-	-	-	-
Stainless Steel													
80	120	-7208K	1750.00	-7168K	1950.00	-4510K	950.00	-4550K	1450.00	-4590K	1950.00	-5010K	239.00
100	130	-4630K	1350.00	-7170K	2250.00	-4610K	1175.00	-4650K	1350.00	-4690K	1650.00	-5020K	205.00
125	130	-4730K	3100.00	-4770K	3500.00	-4710K	1450.00	-4750K	3300.00	-4790K	3500.00	-5030K	308.00
200	200	-4930K	3850.00	-4970K	4950.00	-	-	-4950K	3950.00	-	-	-5050K	1803.00

GROUP 946 FLOOR MATTING

SITESAFE Anti-Fatigue Matting



Standing on a hard floor for prolonged periods without anti-fatigue matting can cause pain and discomfort in the lower legs, feet and back. Fatigue reduces concentration and therefore productivity. Anti-fatigue matting will increase comfort and productivity for workers who stand for long periods and substantially reduces stress, tiredness, aches and pains from standing on hard floors at work. Introducing anti fatigue matting into the workplace can provide staff with a more comfortable environment, which in turn encourages increased efficiency, concentration and productivity.

Diamond Zone

Manufactured from extremely hardwearing rubber capable of operating in high temperature environments. Diamond surface provides greater traction with extended wear and can be easily cleaned. Interlocking tile system enables the user to produce any required length. Also offers insulation against cold floors.

Colour: black.
Thickness: 12.5mm.



Thickness	Size (mm)	Order Code SSF-946	Price/1 TB
12.5mm	700 x 800	-2640D	2653.00

Work Mat

Hard-wearing SBR rubber construction. Raised circular surface for superior slip resistance - suitable for wet conditions. Features a moulded bevelled edge to reduce tripping. Conforms to Slip Resistance Test EN13552 Category R10.

Colour: black.
Thickness: 10mm.

EXTENDED RANGE



Thickness	Size (mm)	Order Code SSF-946	Price/1 TB
10mm	800 x 1200	-8459E	3089.00
	900 x 1500	-8460F	4661.00

Knee Saver Mat

Manufactured from a closed cell PVC/nitrile blend. Reduces knee pain and lower back stress caused by regular kneeling, ideal for pain relief during floor fitting.

Resistant to oils and chemicals.
Colour: black.



Size (mm)	Order Code SSF-946	Price/1 TB
530 x 360 x 25	-4650R	1009.00

Ortho Lite

Cost effective anti fatigue matting. Offers the user relief from fatigue caused by standing. Insulates against cold concrete floors. Ideal for use in dry environments. Pebble surface provides additional traction.

Colour: charcoal.
Thickness: 6mm.



Size (mm)	Order Code SSF-946	Price/1 TB
900 x 1500	-5060F	3714.00
900 x 1820	-5070H	4775.00

Ribbed Mat

Durable mat, manufactured from hardwearing natural rubber. Fine ribbed surface has effective slip-resistance. Provides insulation from cold concrete floors. Can also be used on workbenches to prevent component damage.

Colour: black.
Thickness: 3mm.



Thickness	Size (mm)	Order Code SSF-946	Price/1 TB
3mm	900 x 2500	-6760P	2070.00

Bubble Stand Anti Fatigue Mat

Ideal for dry environments. Bubble surface stimulates constant foot movement to increase blood circulation. Ramped edges for additional safety.

Colour: Black.
Thickness: 14mm.

NEW

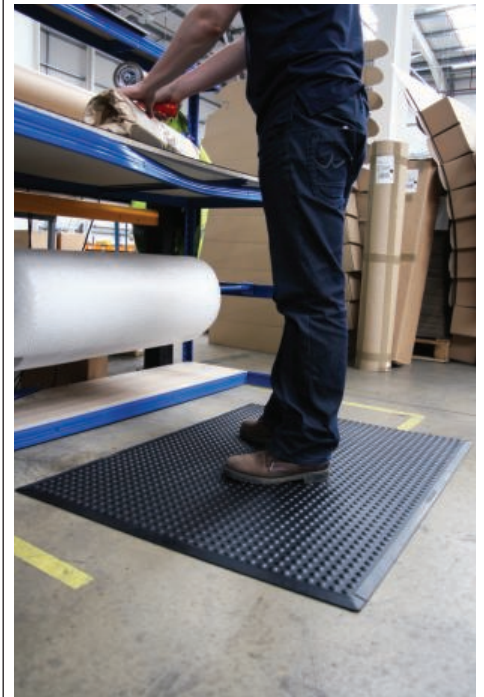

Size (mm)	Order Code SSF-946	Price/1 TB
0.6 x 0.9m	-8520K	3750.00
0.9 x 1.2m	-8523K	5149.00

Premium Anti Fatigue Mat

Heavy duty with 'Diamond Tread' top surface. Comfortable foam backing. Manufactured with two yellow borders and ramped edges all round for additional safety.

Colour: Black.
Thickness: 12.5mm.



Size (mm)	Order Code SSF-946	Price/1 TB
0.9 x 1.5m	-8716K	12875.00
0.9 x 3.0m	-8719K	26500.00

SITE MAINTENANCE



Anti-Slip/Spillage Matting

Manufactured from 100% recycled factory waste. Hard wearing and versatile whilst providing excellent slip resistance. Its two layer tubular construction allows for fast drainage of any water or oils that may be in the workplace.

Colour: black

NEW

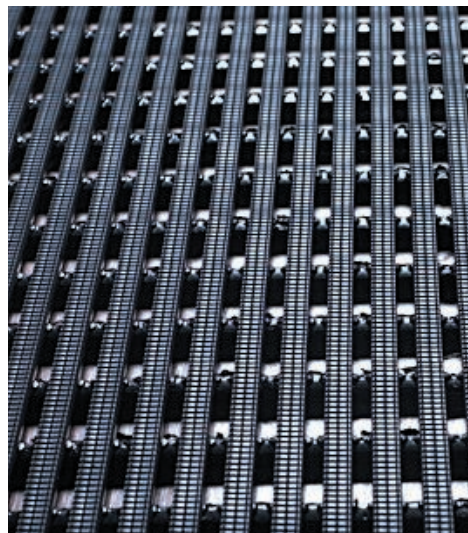

Type	Dimensions	Order Code SSF-946	Price/1 TB
Roll	0.5m x 10m	-7160K	22145.00
	0.75m x 10m	-7170K	33500.00
	1m x 10m	-7180K	41000.00
Matt	0.5m x 0.9m	-7190K	3089.00
	1m x 1.2m	-7200K	6500.00

Entrance Mat

Cost effective entrance mat offering good all round performance. Scrapes dirt and wipes moisture. Slip resistant PVC backing.

Colour: Black. Thickness: 7mm.

NEW



Size (metre)	Order Code SSF-946	Price/1 TB
0.6 x 0.9m	-8706K	1545.00
0.9 x 1.5m	-8709K	3250.00

Barefoot Wet Room Matting

Warm, comfortable, self draining safety matting for barefoot applications. The soft embossed surface combined with anti-bacterial and anti-fungal additives and excellent drainage, offers a safe solution for shower rooms, poolside and changing areas.

NEW

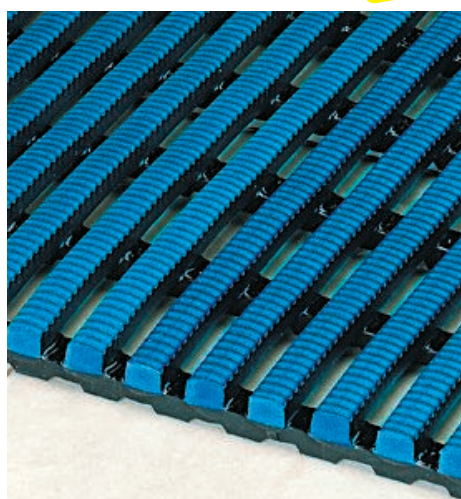

Oxford Blue

Colour	Dimensions	Order Code SSF-946	Price/1 TB
Ocean Blue	0.5m x 10m	-7500K	25750.00
	1m x 10m	-7510K	49000.00
	1.2m x 10m	-7520K	57680.00
Oxford Blue	0.5m x 10m	-7530K	25000.00
	1m x 10m	-7540K	49000.00
	1.2m x 10m	-7550K	57000.00
Charcoal Grey	0.5m x 10m	-7560K	25000.00
	1m x 10m	-7570K	48410.00
	1.2m x 10m	-7580K	56650.00

Anti-Slip Matting

Light, comfortable and economical matting. Insulates against cold floors, reduces standing fatigue and provides excellent slip resistance. (DIN 51130 R11) Floorline is suitable for areas where occasional spillage may occur.

NEW



Colour	Type	Dimensions	Order Code SSF-946	Price/1 TB
Red	Roll	0.6m x 10m	-7010K	21500.00
	Roll	0.9m x 10m	-7020K	31500.00
	Roll	0.6m x 10m	-7050K	21500.00
Blue	Roll	0.9m x 10m	-7060K	29355.00
	Mat	0.6m x 0.9m	-7030K	2575.00
Red	Mat	0.9m x 1.2m	-7040K	5500.00
	Mat	0.6m x 0.9m	-7070K	2500.00
	Mat	0.9m x 1.2m	-7080K	4119.00

FLOOR MATTING Ultimate Anti Slip Matting

The deep tread pattern of Vynagrip offers superior grip, and combined with a high liquid drainage, makes it the ultimate slip resistant matting solution. Vynagrip is resistant to most oils and chemicals making it suitable for the harshest environments.

NEW

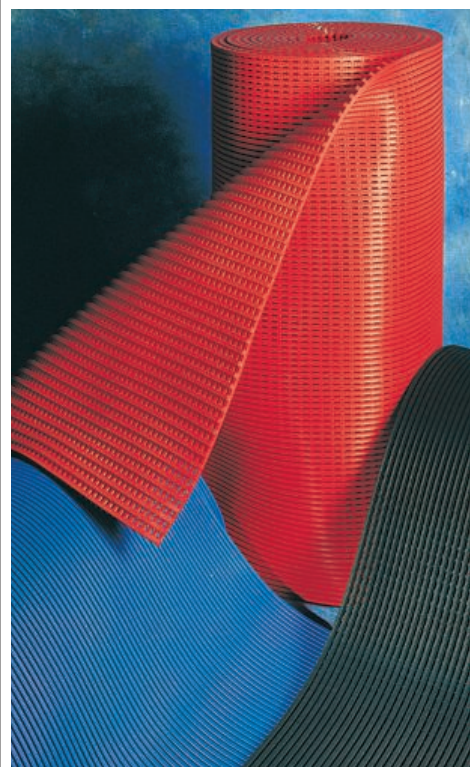

Colour	Type	Dimensions	Order Code SSF-946	Price/1 TB
Red	Roll	0.6m x 10m	-7300K	35020.00
	Roll	0.9m x 10m	-7310K	50985.00
	Roll	1.2m x 10m	-7320K	69010.00
Blue	Roll	0.6m x 10m	-7330K	35000.00
	Roll	0.9m x 10m	-7340K	51000.00
	Roll	1.2m x 10m	-7350K	69000.00
Black	Roll	0.6m x 10m	-7360K	35000.00
	Roll	0.9m x 10m	-7370K	48925.00
	Roll	1.2m x 10m	-7380K	69000.00

SITE MAINTENANCE

PRODUCTS ARE ONLY AVAILABLE VIA YOUR DISTRIBUTOR

MATLOCK Door Controls



This comprehensive range of Door Controls feature varying power sized units for many different door applications. They come with a choice of architectural covers which are each available in 26 different plated or colour coated finishes. To help select the correct closer for you, each unit has a listing showing their key features, certification numbers and fire ratings. Plated arms are available on certain units only, and test certificates are available upon request.

BS EN1154 Classification

This standard classifies door closers using a 6 digit coding system. Each digit relates to a particular feature of the product measured against the standards performance requirements.

Digit (1) - Category of use:

'3' denotes the unit is for closing doors from at least 105°. '4' denotes the unit is for closing doors from 180° open.

Digit (2) - Durability:

'8' successfully completed 500,000 test cycles.

Digit (3) - Test door mass/size:

Seven grades are identified as shown in the table below (where a closer provides a range of power sizes both the minimum and maximum sizes shall be shown):

Power size	Test door mass	Recommended door leaf width
1	20kg	750mm
2	40kg	850mm
3	60kg	950mm
4	80kg	1100mm
5	100kg	1250mm
6	120kg	1400mm
7	160kg	1600mm

Digit (4) - Fire behaviour:

'0' denotes the unit is **NOT** suitable for use on fire/smoke doors. '1' denotes the unit **IS** suitable for use on fire/smoke doors.

Digit (5) - Safety in use:

'1' all door closer units are required to satisfy the essential requirement of safety in use.

Digit (6) - Corrosion-resistance:

'0' - indicates no defined corrosion-resistance, '1' - indicates mild corrosion-resistance, '2' - indicates a moderate level of corrosion-resistance, '3' - indicates high corrosion-resistance, '4' - indicates very high corrosion-resistance.

Within this section units have been tested to **BS EN1154**, with many units also having been tested to current Certified testing and CE test criteria. Therefore, the 6 digit classification is shown against each of the varying units, thus indicating their performance and grading under **BS EN1154**.

SITE MAINTENANCE

Budget Contract Door Closer

Size 3 Mechanism 28730

Silver finish. **CE** tested. Closing force size 3 (**EN1154**). Maximum door width 950mm. Suitable for doors 40 - 60kg. Adjustable latch action. Fire tested to **BS EN1634-1**. 1 hour fire rated. Self handing (fits to left or right hinged doors). 180° opening (retains control of door when opened 180°).

Specification:

CE 1121.

Certifire approved: CF600.

Meets EN1154: yes.

Fire tested to EN1634: 1½ hours.

Power size: 2 - 4.

Application: universal.

Arm assembly: projecting arm.

Architectural cover: mechanism only or 92 cover.

Closing speed: adjustable.

Latch action: adjustable.

Stand open option: yes.

(NOT for use on fire doors).

Backcheck: no.

Delayed action: no.

Guarantee: 10 years.

Overhead Door Closer

Size 2 - 4 Mechanism 28932

Silver or plated finish. **CE** tested. Certifire approved **CF600**. Closing force size 3 - 4 (**EN1154**). Maximum door width 850 - 1100mm. Suitable for doors 40 - 80kg. Fire tested to **BS EN1634**. 1 hour fire rated. Adjustable check action. Independent on/off latch action. Self handing (fits to left or right hinged doors). 180° opening (retains control of door when opened 180°).

Specification:

CE 1121.

Certifire approved: CF600.

Meets EN1154: yes.

Fire tested to EN1634: 2 hours.

Power size: 3 - 4.

Application: universal.

Arm assembly: projecting arm.

Architectural cover: 91.

Check action: adjustable.

Closing speed: adjustable.

Stand open option: yes.

(NOT for use on fire doors).

Backcheck: yes.

Delayed action: yes.

Guarantee: 10 years.

Concealed Chain Door Closer

Brass finish. Concealed spring type closer. Spring tension closing force adjustable. Certified to **BS 476 Pt. 22:1987**. ½ hour fire rated. Left or right hand fitting. Suitable for use on doors up to 50kg.



Finish	Order Code MTL-949	Price/1 TB
Chrome	-4070K	205.00
Brass	-4080K	263.00

Electro-Magnetic Fire Stay

Silver or plated finish. Electro-magnetic holds open fire doors but releases in the event of fire. Closing force size 4 (**EN1155**). Maximum door width 950 - 1100mm. Suitable for doors 60 - 80kg. Adjustable check action. Adjustable latch action. Hold open from 70° - 180°.



CE		3	8	3	1	1	3
1121		(1)	(2)	(3)	(4)	(5)	(6)
Description	Finish	Order Code MTL-949	Price/1 TB				
Mechanism only	Silver	-4030K	1954.00				
Covered Unit	Silver	-4040K	2348.00				



CE		4	8	4 ₃	1	1	3
1121		(1)	(2)	(3)	(4)	(5)	(6)
Description	Finish	Order Code MTL-949	Price/1 TB				
Covered Unit	Silver	-4010K	4624.00				
Covered Unit	Plated	-4020K	5574.00				

CE		3	8	1	1	1	3
1121		(1)	(2)	(3)	(4)	(5)	(6)
Description	Finish	Order Code MTL-949	Price/1 TB				
Covered Unit	Silver	-4050K	26196.00				
Covered Unit	Plated	-4060K	28092.00				

MATLOCK Panic Hardware



This panic hardware range of emergency exit devices contains products that are certified to the European CEN standards **BS EN179 & BS EN1125** and offers a design to give optimum safety and security. All products meet with the required standards in today's market. They have an anti-thrust mechanism to protect against attack, they carry a ten year manufacturer's guarantee and are two hour fire rated. Standard sized units are suitable for doors up to 2440mm high and 1220mm wide. Special sized vertical shoots, horizontal bars, keeps and pullman catch kits are available on request.

BS EN1125 Classification

This is the European standard for Panic Exit Devices. This determines that a Panic device must be fitted where members of the public are present and have no prior knowledge of the exit or hardware.

BS EN179 Classification

This is the European standard for Emergency Exit Devices. This determines that in emergency situations occupants will have prior knowledge of the exit and panic situation is unlikely to occur. Each standard is tested and evaluated and a 9 digit code is produced.

BS EN 1125 & BS EN 179 are harmonised under the Construction Products Directive and products must therefore carry the CE mark.

Push Bar Panic Latch

Suitable for public areas. Certified for use on fire doors. CE marked for safety.

Tested to **BS EN 179** and **EN1125**. 2 hour fire rated.



Finish	Order Code	Price/1 TB
Silver	MTL-949 -6010K	4387.00

Push Pad Panic Latch

Suitable for offices, business premises etc. Certified for use on fire doors. CE marked for safety.

Tested to **BS EN 179** and **EN1125**. 2 hour fire rated.



Finish	Order Code	Price/1 TB
Silver	MTL-949 -6020K	3677.00

Outside Access Device

Suitable for use on fire doors. Supplied with euro cylinder. Three keys included. 2 hour fire rated.



Finish	Order Code	Price/1 TB
Silver	MTL-949 -6040K	4861.00

Push Bar Single Panic Bolt

Suitable for single and double flush fitting doors. Certified for use on fire doors. CE marked for safety.

Tested to **BS EN 179** and **EN1125**. 2 hour fire rated.



Finish	Order Code	Price/1 TB
Silver	MTL-949 -5990K	5810.00

Push Pad Panic Bolt

Suitable for offices, business premises etc. Certified for use on fire doors. CE marked for safety.

Tested to **BS EN 179** and **EN1125**. 2 hour fire rated.



Finish	Order Code	Price/1 TB
Silver	MTL-949 -6030K	5574.00

Double Panic Bolt Set

Suitable for rebated double doors. Certified for use on fire doors. CE marked for safety. Tested to **BS EN 179** and **EN1125**. 2 hour fire rated.



Finish	Order Code	Price/1 TB
Silver	MTL-949 -6000K	10408.00

SITE MAINTENANCE

PRODUCTS ARE ONLY AVAILABLE VIA YOUR DISTRIBUTOR

MATLOCK 5-Lever Mortice Detainer Sashlock

Kitemarked to **BS3621**. Insurance approved sashlock, easily reversible latchbolt, five detainer mechanism, 64mm (2½") and 76mm (3") case size available. Supplied with square forend and strike. Supplied with two keys. Satin chrome plate or polished brass finish.



Size	Order Code MTL-949	Price/1 TB
Satin Chrome Plated Finish		
64mm (2½")	-4090K	1543.00
76mm (3")	-4100K	1543.00
Polished Brass Finish		
64mm (2½")	-4110K	1543.00
76mm (3")	-4120K	1543.00

3-Lever Mortice Deadlock

64mm (2½") and 76mm (3") case size available. Supplied with radius forend and strike. Supplied with two keys. Satin chrome plate and polished brass finish.



Size	Order Code MTL-949	Price/1 TB
Satin Chrome Plated Finish		
64mm (2½")	-4250K	1007.00
76mm (3")	-4260K	1007.00
Polished Brass Finish		
64mm (2½")	-4270K	1007.00
76mm (3")	-4280K	1007.00

3-Lever Mortice Sashlock

Easily reversible latchbolt, adjustable springing feature, 64mm (2½") and 76mm (3") case size available, supplied with square forend and strike. Supplied with two keys. Satin chrome plate or polished brass finish.



Size	Order Code MTL-949	Price/1 TB
Satin Chrome Plated Finish		
64mm (2½")	-4210K	1069.00
76mm (3")	-4220K	1069.00
Polished Brass Finish		
64mm (2½")	-4230K	1069.00
76mm (3")	-4240K	1069.00

Euro Profile Mortice Sashlock Case

Easily reversible latchbolt for internal and external door use. 64mm (2½") and 76mm (3") case size available. Brass or nickel plated square forend and strike. Satin chrome plate or polished brass finish.



Size	Order Code MTL-949	Price/1 TB
Satin Chrome Plated Finish		
64mm (2½")	-4170K	1069.00
76mm (3")	-4180K	1069.00
Polished Brass Finish		
64mm (2½")	-4190K	1069.00
76mm (3")	-4200K	1069.00

Europrofile Cylinder & Turn

70mm (35/35). Polished brass or satin chrome plate finishes. Supplied with two keys and fixing screw.



Size	Order Code MTL-949	Price/1 TB
Satin Chrome Plated Finish		
35mm/35mm	-4430K	617.00
Polished Brass Finish		
35mm/35mm	-4440K	617.00

Europrofile Double Cylinder

70mm (35/35). Polished brass or satin chrome plate finishes. Supplied with two keys and fixing screw.



Size	Order Code MTL-949	Price/1 TB
Satin Chrome Plated Finish		
35mm/35mm	-4410K	617.00
Polished Brass Finish		
35mm/35mm	-4420K	617.00

Budget Lever on Pressed Backplate

Aluminium finish.

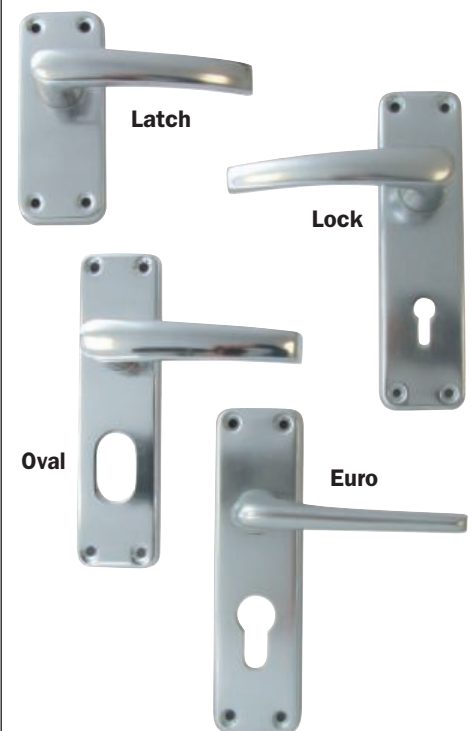

Type	Order Code MTL-949	Price/1 TB
Latch	-5940K	523.00
Lock	-5950K	570.00
Euro	-5960K	570.00
Oval	-5970K	570.00

SITE MAINTENANCE

MATLOCK Light Butt Hinges

For general purpose use and in domestic situations. Self colour Finish.

Supplied in pairs.

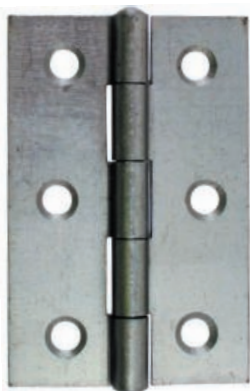

Size (mm)	Size (mm)	Order Code MTL-949	Price/Pr TB
25	25 x 15 x 3	-8200K	111.00
38	38 x 18 x 5	-8210K	122.00
50	50 x 22 x 5	-8220K	128.00
65	65 x 25 x 7	-8230K	141.00
75	75 x 28 x 7	-8240K	170.00
100	100 x 40 x 10	-8250K	196.00

Rising Butt Hinges

Self closing hinges that also provide floor to ground clearance as they are opened. Available in a choice of left or right hand opening. Self colour.



-8340K

Supplied individually, boxed in 5s (pairs).

Size (mm)	Opening	Order Code MTL-949	Price/Pr TB
75 x 45 x 15	Left Hand	-8340K	273.00
75 x 45 x 15	Right Hand	-8350K	266.00

Single Action Spring Hinges

A very competitively priced hinge having all the features and operating abilities of more expensive products on the UK market. Supplied with screws, spare adjustment pins and cranking bar. Lacquered silver finish.

Supplied in pairs.



Size (mm)	Size (mm)	Order Code MTL-949	Price/Pr TB
75	75 x 45 x 20	-8310K	720.00
100	100 x 50 x 20	-8320K	773.00

Stainless Steel 2 Ball Bearing Butt Hinge

523CE Polished or satin stainless steel finish. Grade 304 stainless steel. One hour fire tested. Stainless steel pin. Complete with screws.



Finish	Size (mm)	Order Code MTL-949	Price/Pr TB
Stainless Steel			
Satin	100 x 75 x 3	-4450K	523.00
Stainless Steel			
Polished	100 x 75 x 3	-4460K	541.00

Polished Brass 2 Ball Bearing Butt Hinge

525CE Polished brass or brass plated finishes. One hour fire tested. Stainless steel pin. Complete with screws.



Size (mm)	Order Code MTL-949	Price/Pr TB
100 x 75 x 3	-4470K	997.00

Polished Brass Butt Hinge

508 Double phosphor bronze washed finish. Brass pin. One year guarantee.

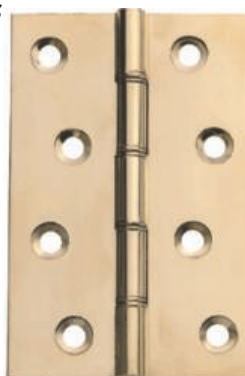

Size (mm)	Order Code MTL-949	Price/Pr TB
100 x 75 x 3	-4480K	397.00

Aluminium Barrel Bolts

Internal domestic locking bolt. Supplied with wood screws.

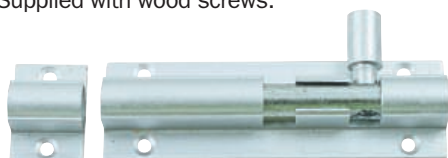

Size (mm)	Finish	Order Code MTL-949	Price/1 TB
50		-8140K	168.00
75	Aluminium	-8150K	195.00
100		-8160K	205.00

Digital Door Locks

Digital door locks suitable for: offices, banks, warehouses, laboratories, schools, hospitals, flats, apartments or any restricted areas.

Features:
 Resettable combination.
 Tamper-proof latch bolt.
 Weather resistant.
 Simple to fit.
 Internal and external applications.



Available with or without key override

Body Finish	Key Lock Override	Order Code MTL-949	Price/1 TB
Satin Chrome	No	-5020K	4429.00
Satin Chrome	Yes	-5040K	8002.00

Hat & Coat Hooks

Finished in aluminium, stainless steel and brass.



Stainless Steel

Finish	Order Code MTL-949	Price/1 TB
Aluminium	-5880K	102.00
Stainless Steel	-5890K	224.00
Brass	-5900K	925.00

SITE MAINTENANCE

MATLOCK Oval Padlock Bolt

A simple and efficient lockable gate securing bolt.

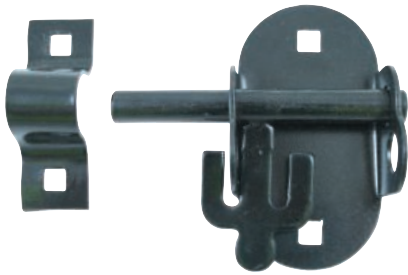

Size (mm)	Finish	Order Code MTL-949	Price/1 TB
100	Galvanised	-7830K	361.00
100	Black	-7835K	266.00

Garage Door Drop Bolts

A very strong product with numerous applications. Made from galvanised steel.

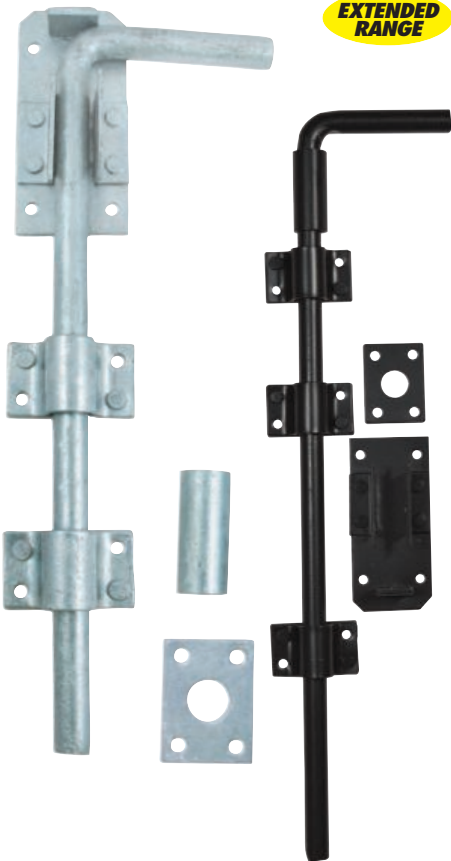

Size (mm)	Finish	Order Code MTL-949	Price/1 TB
460	Black	-7060K	876.00
600	BZP	-7075K	979.00

Spring Loaded Bolts

Spring loaded bolt suitable for metal or wooden gates.

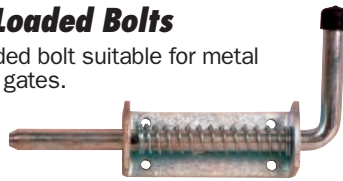

Shoot Dia. (mm)	Finish	Order Code MTL-949	Price/1 TB
10 (3/8")	Zinc Plated	-7670K	490.00
12 (1/2")	Zinc Plated	-7680K	531.00
15 (5/8")	Zinc Plated	-7690K	773.00

Spring Loaded Animal Bolts

Spring loaded bolt with staple on plate, suitable for gates, paddocks etc.



Length (mm)	Finish	Order Code MTL-949	Price/1 TB
12 (1/2")	Zinc Plated	-7850K	634.00

Tower Bolts

General purpose bolts for shed doors etc.



Length (mm)	Finish	Order Code MTL-949	Price/1 TB
76 (3")	Black	-7760K	114.00
101 (4")	Galvanised	-7770K	202.00
101 (4")	Black	-7780K	125.00
152 (6")	Galvanised	-7790K	234.00
152 (6")	Black	-7800K	187.00
203 (8")	Black	-7810K	236.00
254 (10")	Black	-7820K	316.00

Auto Pig Lock Bolts

Autolock bolts with bottom guard to prevent fouling of the latch.



Length (mm)	Finish	Order Code MTL-949	Price/1 TB
203 (8")	Zinc Plated	-7840K	681.00

Brenton Bolts

Padlockable security bolt.



Length x Shoot Dia. (mm)	Finish	Order Code MTL-949	Price/1 TB
101 x 12 (4" x 1/2")	Galvanised	-7710K	274.00
152 x 12 (6" x 1/2")	Galvanised	-7720K	293.00
203 x 12 (8" x 1/2")	Galvanised	-7730K	369.00
152 x 15 (6" x 5/8")	Galvanised	-7740K	458.00
203 x 15 (8" x 5/8")	Galvanised	-7750K	475.00

Auto Gate Catches

Plate Pin - Medium Duty

For use on all types of gate. With cranked striker pin. Striker pin is plate type for fitting onto the surface of a post or fence. Packed complete with all fixing screws.

Supplied individually, boxed in 5s.

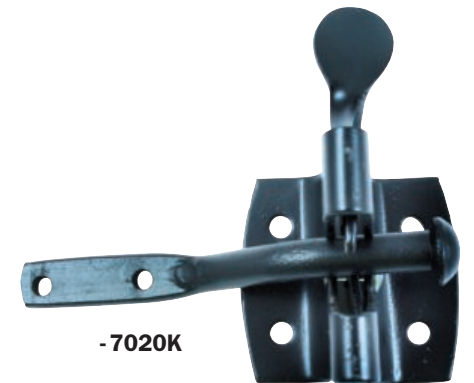
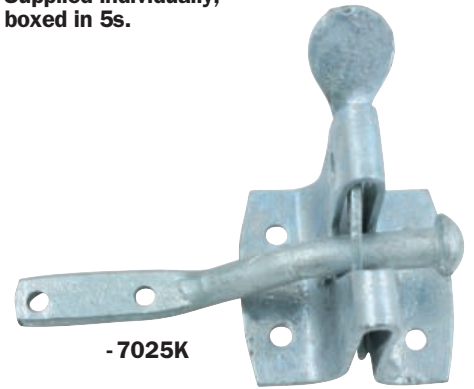

Size (mm)	Finish	Order Code MTL-949	Price/1 TB
32	BZP	-7010K	145.00
50	Black	-7020K	140.00
50	BZP	-7025K	140.00
57	BZP	-7030K	300.00

Door/Gate Stop

Door and gate stop. Supplied complete with screws and rubber stopper.



Length (mm)	Finish	Order Code MTL-949	Price/1 TB
152 (6")	Grey Japanned	-7700K	651.00

Medium Strap Hinges

Supplied as pairs. Commonly used for lift-up lids and traps.

Length (mm)	Finish	Order Code MTL-949	Price/Pr TB
203 (8")	Self-colour	-7640K	445.00
254 (10")	Self-colour	-7650K	694.00
305 (12")	Self-colour	-7660K	1017.00

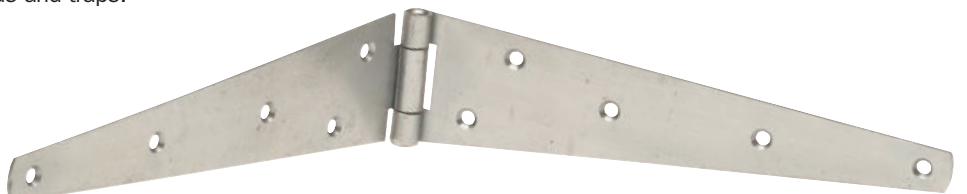

SITE MAINTENANCE



MATLOCK Safety Hasps & Staples

Secure fixings are concealed by hasp when in locked position.



Length (mm)	Finish	Order Code MTL-949	Price/1 TB
75 (3")	Black	-6060K	170.00
115 (4½")	Black	-6070K	196.00
150 (6")	Black	-6080K	222.00
75 (3")	Zinc Plated	-7918K	186.00
101 (4")	Zinc Plated	-7920K	179.00
152 (6")	Zinc Plated	-7930K	200.00

Heavy Duty Vertical Hasp & Staples



Length (mm)	Finish	Order Code MTL-949	Price/1 TB
150 (6")	Black	-6120K	608.00
150 (6")	Galvanised	-6140K	670.00

Short Pattern Heavy Hasp & Staple

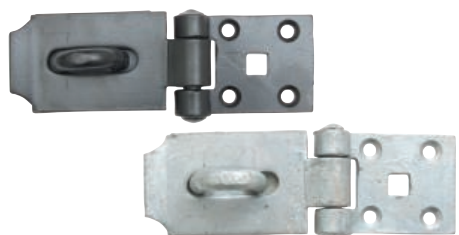

Length (mm)	Finish	Order Code MTL-949	Price/1 TB
150 (6")	Black	-6160K	469.00
150 (6")	Galvanised	-6180K	495.00

Swivel Hasp & Staple

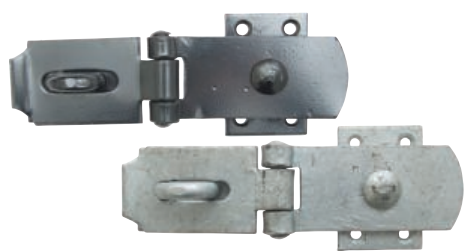

Length (mm)	Finish	Order Code MTL-949	Price/1 TB
200 (8")	Black	-6220K	376.00
250 (9")	Black	-6230K	392.00
200 (8")	Galvanised	-6250K	387.00
250 (9")	Galvanised	-6260K	409.00

Heavy Duty Hasp & Staples

Rotating and padlockable.



Length (mm)	Finish	Order Code MTL-949	Price/1 TB
203 (8")	Galvanised	-7080K	369.00
203 (8")	Black	-7090K	369.00
254 (10")	Black	-7100K	515.00

Security Hasps

Manufactured from hardened steel with a duplex nickel plated anti-corrosive finish. The hinge pins, fixings and assembly are concealed with a folded edge for tamper protection. Supplied with fixing screws.

Double Hinged:

Models can be used for internal and external corner mounting.

Triple Hinged:

Models also allow for use on non-flush fitting (stepped) surfaces.

8120, 8110, 8100* & 8150*:

For use on standard duty and domestic applications.

8200* & 8160*:

For use on medium duty applications.

*Supplied complete with door reinforcement plates for improved security.

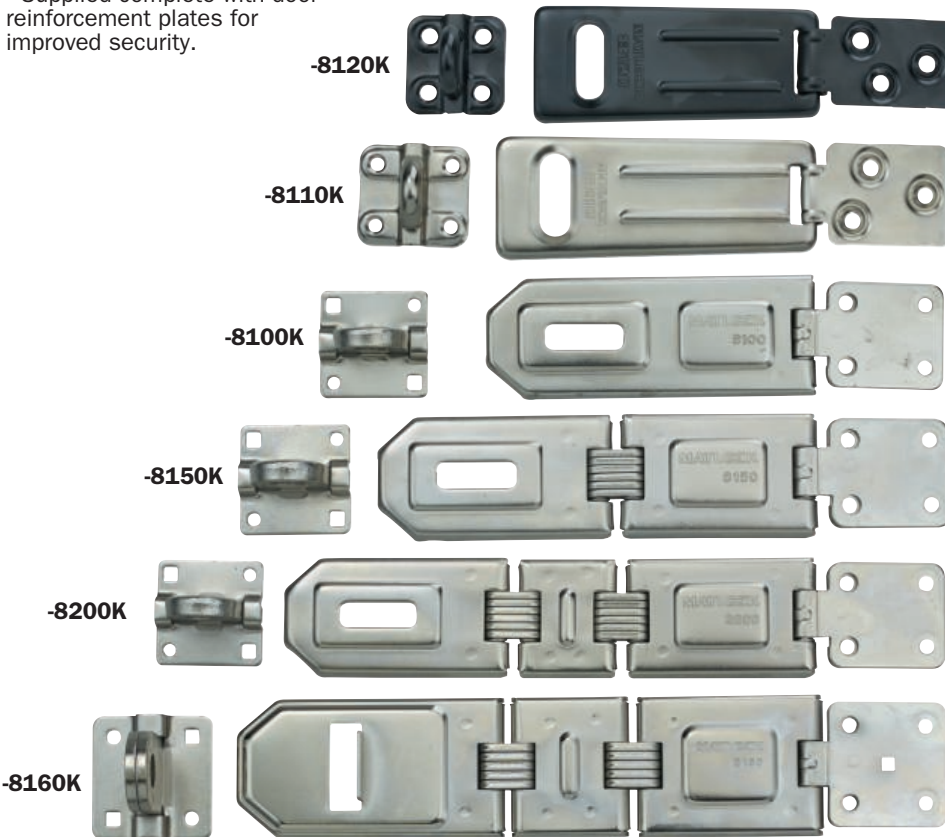

Product Number	Shackle Type	Hinge Type	Size (mm)	To Suit Shackle	Security Rating	Order Code MTL-950	Price/1 TB
8120	Vertical	Single	92 x 37	8mm	2	-8120K	176.00
8110	Vertical	Single	120 x 45	8mm	2	-8110K	377.00
8100	Horizontal	Single	125 x 45	11mm	3	-8100K	236.00
8150	Horizontal	Double	160 x 45	11mm	3	-8150K	464.00
8200	Horizontal	Triple	200 x 45	11mm	3	-8200K	467.00
8160	Vertical	Triple	258 x 62	13mm	3	-8160K	724.00

Gate Spring

A general purpose return spring for assisting in the closure of gates.

Supplied individually, boxed in 10s.



Size (mm)	Finish	Order Code MTL-949	Price/Pr TB
200	Black	-7970K	651.00
250	Black	-7980K	424.00

Cast Iron Hot Bed Handles

Supplied individually, boxed in 25s.



Size (mm)	Finish	Order Code MTL-949	Price/1 TB
150	Black	-8030K	109.00

Traditional Cast Cabin Hooks

For restraining doors and gates. Often used in stabling. Supplied individually packed and complete with all fixing screws.

Boxed in 5s.



Length (mm)	Finish	Order Code MTL-949	Price/1 TB
100	Black	-7905K	160.00
150	Black	-7915K	266.00
101 (4")	Galvanised	-7900K	315.00
152 (6")	Galvanised	-7910K	379.00

SITE MAINTENANCE

MATLOCK Security Ratings

All padlocks have a rating to indicate how secure they are, this is based on material, hardening, extra coating, shackle diameter, body width, and other security features such as anti-pick locks and 3, 4, 5 or 6 pin cylinders.

SECURITY RATING



- Rating Uses
- 1 - 2 Minimum security for indoor and outdoor use on tackle boxes, suitcases and drawers etc.
 - 3 - 4 Minimum to medium security for indoor and outdoor use on garages, cabinets, toolboxes, gates, truck doors, lockers, sheds, bicycles etc.
 - 5 - 6 Medium security for indoor and outdoor use on garages, cabinets, toolboxes, gates, truck doors, lockers, sheds, bicycles etc.
 - 7 - 8 Medium to maximum security for indoor and outdoor use on store front and factory gates, large toolchests, construction site storage etc.
 - 9 - 10 Maximum security for indoor and outdoor use on store front and factory gates, large tool chests and construction site storage etc.



Brass

Solid brass body with a hardened steel shackle and a double locking mechanism. For indoor and outdoor use on minimum to medium security items. 20mm: 3 pin cylinder. 30 and 40mm: 4 pin cylinder, 50 and 60mm: 5 pin cylinder.
*Single locking only.



HARDENED SHACKLE



Body Width	Shackle Diameter x Clearance	Rating (1 - 10)	Order Code MTL-950	Price/1 TB
20mm	3.7 x 10.3mm	2*	-6722K	165.00
30mm	4.8 x 15mm	3	-6733K	263.00
30mm	4.8 x 50mm	3	-6732K	321.00
40mm	4.8 x 22mm	3	-6743K	361.00
40mm	7.0 x 50mm	4	-6745K	393.00
50mm	7.0 x 26mm	4	-6754K	662.00
60mm	8.8 x 27mm	4	-6764K	782.00
Key Blank to suit 20mm			-9900K	37.00
Key Blank to suit 30 & 40mm			-9910K	37.00

Brass - Stainless Steel Shackle

Traditional style brass bodied padlock with a stainless steel shackle and a double locking mechanism. For indoor and outdoor use on many minimum to medium security items. 20mm: 3 pin cylinder, 30 and 40mm: 4 pin cylinder, 50 and 60mm: 5 pin cylinder. * Single locking only



Body Width	Shackle Diameter x Clearance	Rating (1 - 10)	Order Code MTL-950	Price/1 TB
20mm	3.7 x 10.3mm	2*	-7022K	185.00
30mm	4.8 x 15mm	3	-7033K	357.00
40mm	4.8 x 22mm	3	-7043K	411.00
50mm	7.0 x 26mm	4	-7054K	662.00
60mm	8.8 x 27mm	4	-7064K	823.00
Key Blank to suit 20mm			5g -9900K	37.00
Key Blank to suit 30 & 40mm			5g -9910K	37.00

Brass Slimline

Solid brass body with a hardened steel changeable shackle. For indoor and outdoor use on minimum to medium security items.



EXTENDED RANGE



Body Width	Shackle Diameter x Clearance	Rating (1 - 10)	Order Code MTL-950	Price/1 TB
20mm	3.2 x 12mm	2	-6820K	145.00
25mm	4.8 x 15mm	3	-6825K	157.00
30mm	4.8 x 15mm	3	-6830K	169.00
30mm	5 x 43mm	3	-6832K	200.00
40mm	6 x 20mm	4	-6840K	228.00
50mm	7 x 25mm	4	-6850K	315.00
Pack of 4				
20mm	3.2 x 12mm	2	-7970K	350.00
25mm	4.8 x 15mm	3	-7975K	450.00
30mm	4.8 x 15mm	3	-7980K	550.00
30mm	5 x 43mm	3	-7985K	600.00
40mm	6 x 20mm	4	-7990K	750.00
50mm	7 x 25mm	4	-7995K	950.00

Laminated Brass - Combination Type

Laminated brass body with a brass shackle and a double locking mechanism. Available with four number tumbler (10,000 combinations) or three number tumbler (1,000 combinations). For indoor and outdoor use on minimum to medium security items.



Body Width	Shackle Dia. x Clearance	Rating (1 - 10)	Combination Number	Order Code MTL-950	Price/1 TB
40mm	6 x 25mm	3	3	-6203K	821.00
46mm	8 x 25mm	3	4	-6263K	931.00

Lock Block

With a solid brass body and molybdenum shackle. Designed to provide medium to maximum security for indoor and outdoor use on store front and factory gates, large toolchests, construction site storage etc.
* keyed alike



NEW



Body Width	Shackle Dia. x Clearance	Rating (1 - 10)	Order Code MTL-950	Price/1 TB
63mm	8 x 13.5mm	8	-8840K	794.00
83mm	11 x 16mm	8	-8860K	1360.00
*83mm	11 x 16mm	8	-8900K	1473.00

Stainless Steel Disc Padlocks

With stainless steel body and hardened steel shackle, these disc padlocks are designed to provide medium to maximum security for indoor and outdoor use on store front and factory gates, large toolchests, construction site storage etc. Available in keyed differently and keyed alike versions.



NEW



Shackle Dia. x Clearance:
9.5 x 17.3mm.

Type	Body Width	Order Code MTL-950	Price/1 TB
Keyed Differently	70mm	-8240K	799.00
Keyed Alike		-8250K	850.00

Laminated Brass

Laminated brass body with a hardened steel shackle, a double locking mechanism and a pin cylinder. For indoor and outdoor use on minimum to medium security items.
Key change every 1,000.



HARDENED SHACKLE



Body Width	Shackle Diameter x Clearance	Rating (1 - 10)	Order Code MTL-950	Price/1 TB
40mm	6.3 x 20mm	4	-5824K	493.00
50mm	8.8 x 25mm	4	-5834K	821.00
Key Blank			-9950K	37.00

SITE MAINTENANCE

MATLOCK Brass - Cross Key

Solid brass body with a hardened steel shackle and a double locking mechanism. Fitted with a dual lever 4 row 16 pin cylinder which has 1000 different key numbers. For indoor and outdoor use on minimum to medium security items.
Key change every 100,000.



Body Width	Shackle Diameter x Clearance	Rating (1 - 10)	Weight each	Order Code MTL-950	Price/1 TB
40mm	6.8 x 25mm	4	255g	-3844K	823.00
50mm	8.8 x 32mm	5	380g	-3855K	840.00
60mm	11 x 35mm	5	540g	-3865K	970.00

Brass Anti-Pick Padlock

Solid brass body with a hardened steel changeable shackle and a double locking mechanism. Fitted with a hardened steel cover plate and an anti-pick 6 pin brass cylinder. For indoor and outdoor use on minimum to medium security items.
Key change every 20,000.



Body Width	Shackle Diameter x Clearance	Rating (1 - 10)	Weight each	Order Code MTL-950	Price/1 TB
38 x 76	6.3 x 25mm	4	310g	-3054K	912.00
38 x 76	6.3 x 75mm	4	335g	-3094K	917.00
50 x 76	9.5 x 25mm	6	420g	-3206K	950.00
50 x 76	9.5 x 50mm	6	445g	-3226K	1029.00
50 x 76	9.5 x 75mm	6	475g	-3236K	1133.00
Key Blank			5g	-9930K	37.00

Brass - Anti-Pick Weatherproof

Solid brass body with a hardened stainless steel changeable shackle and a double locking mechanism. Fitted with a hardened steel cover plate and an anti-pick 6 pin brass cylinder. Completely weatherproof padlock which is suitable for use in the harshest corrosive conditions on minimum to medium security items.
Key change every 20,000.



Body Width	Shackle Diameter x Clearance	Rating (1 - 10)	Weight each	Order Code MTL-950	Price/1 TB
38mm	6.3 x 25mm	4	310g	-3554K	927.00
38mm	6.3 x 50mm	4	320g	-3574K	953.00
45mm	8 x 25mm	5	370g	-3655K	1029.00
45mm	8 x 50mm	5	385g	-3675K	1082.00
50mm	9.5 x 25mm	6	415g	-3756K	1108.00
50mm	9.5 x 50mm	6	450g	-3776K	1133.00
Key Blank			5g	-9930K	37.00

HARDENED SHACKLE

4 Pin Strong Padlocks

4 pin padlocks available in a range of colours. Designed to provide minimum to medium security for indoor and outdoor use on garages, cabinets, toolboxes, gates, truck doors, lockers, sheds and bicycles etc. Available in keyed differently and keyed alike versions.

NEW



Colour	Body Width	Shackle Dia. x Clearance	Order Code MTL-950 Keyed Diff.	Keyed Alike	Price/1 TB
Black			-7120K	-7160K	308.00
Blue	40mm	7 x 21.5mm	-7125K	-7165K	308.00
Green			-7130K	-7170K	308.00
Orange			-7135K	-7175K	308.00
Red	40mm	7 x 21.5mm	-7140K	-7180K	308.00
Yellow			-7145K	-7185K	308.00

Weather-Resistant - Long Shackle

Laminated steel body with hardened steel shackle, double locking mechanism and anti-pick cylinder. The PU coating makes this the most weather-resistant padlock. Ideally suitable for medium security for indoor and outdoor use in the harshest corrosive environments. For use on marine/brewery storage, haulage and warehouses etc. Available in a range of colours. All fitted with a weather-resistant key cover.



Body Width	Colour	Shackle Dia x Clearance	Rating (1 - 10)	Order Code MTL-950	Price/1 TB
45mm	Red	8.1 x 55mm	5	-7615K	443.00
54mm	Yellow	10.7 x 46mm	6	-7626K	561.00
Key Blank				-9950K	37.00

Laminated Steel

Laminated steel body with a hardened steel shackle, a double locking mechanism and a 5 pin cylinder. For indoor and outdoor use on medium to maximum security items.
Key change every 1,000 (30mm every 200).



Body Width	Shackle Diameter x Clearance	Rating (1 - 10)	Weight each	Order Code MTL-950	Price/1 TB
30mm	5.2 x 18.5mm	4	220g	-5514K	232.00
40mm	6.3 x 25mm	5	265g	-5525K	263.00
44mm	7.0 x 25mm	5	330g	-5555K	284.00
50mm	8.8 x 25mm	7	500g	-5587K	393.00
65mm	11 x 34mm	8	600g	-5598K	603.00

HARDENED SHACKLE

GROUP 950 PADLOCKS

MATLOCK Solid Steel Heavy Duty

Hardened solid steel, chrome and duplex nickel plated body with a hardened changeable steel shackle. Fitted with a double locking mechanism, hardened steel cover plate and an anti-pick six pin brass cylinder. For indoor and outdoor use on maximum security items.
Key change every 20,000.



Body Width	Shackle Diameter x Clearance	Rating (1 - 10)	Weight each	Order Code MTL-950	Price/1 TB
63.5 x 76	11 x 25mm	9	680g	-1509K	1273.00
63.5 x 76	11 x 50mm	9	725g	-1529K	1324.00
63.5 x 76	11 x 75mm	9	770g	-1539K	1381.00

Aluminium - Anti-Pick Weatherproof

Solid anodised lightweight aluminium body with a hardened stainless steel changeable shackle. Fitted with an anti-pick 6 pin brass cylinder and a double locking mechanism. Weatherproof padlock which is suitable for use in the harshest corrosive conditions on medium security items.
Key change every 20,000.



Body Width	Shackle Diameter x Clearance	Rating (1 - 10)	Weight each	Order Code MTL-950	Price/1 TB
38mm	6.3 x 50mm	5	200g	-5025K	823.00
50mm	9.5 x 25mm	5	255g	-5205K	876.00
50mm	9.5 x 50mm	5	280g	-5225K	876.00

Laminated Steel - Combination Type

Laminated steel, nickel plated body with a hardened steel shackle and a double locking mechanism. Available with four number tumbler (10,000 combinations) or three number tumbler (1,000 combinations). For indoor and outdoor use on minimum to medium security items.



Body Width	Shackle Dia. x Clearance	Rating (1 - 10)	Combination Number	Weight each	Order Code MTL-950	Price/1 TB
40mm	6 x 25mm	4	3	185g	-6004K	603.00
40mm	6 x 45mm	4	3	200g	-6024K	547.00
46mm	8 x 25mm	4	4	270g	-6064K	712.00

Solid Brass Combination Padlocks

Solid brass padlocks designed to provide minimum to medium security for indoor and outdoor use on garages, cabinets, toolboxes, gates, truck doors, lockers, sheds and bicycles etc. Available in a range of sizes. Solid brass body with hardened steel shackle and 3 or 4 digit combination.



Body Width	Shackle Dia. x Clearance	No. of Dials	Pack Quantity	Order Code MTL-950	Price/1 TB
20mm	3.0 x 21.7mm	3	1	-8020K	340.00
20mm	3.0 x 21.7mm	3	4	-8070K	1190.00
30mm	5.0 x 25.0mm	3	1	-8030K	459.00
30mm	5.0 x 25.0mm	3	4	-8080K	1757.00
40mm	6.0 x 26.0mm	4	1	-8040K	567.00
40mm	6.0 x 26.0mm	4	4	-8090K	2210.00

Solid Steel Anti-Pick

Hardened solid steel, chrome and duplex nickel plated body with a hardened steel changeable shackle and a double locking mechanism. Fitted with a hardened steel cover plate and an anti-pick 6 pin brass cylinder. For indoor and outdoor use on medium to maximum security items.
Key change every 20,000.

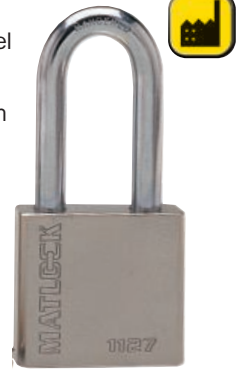

Body Width	Shackle Diameter x Clearance	Rating (1 - 10)	Weight each	Order Code MTL-950	Price/1 TB
50 x 76	9.5 x 25mm	7	400g	-1107K	1029.00
50 x 76	9.5 x 50mm	7	430g	-1127K	1108.00
50 x 76	9.5 x 75mm	7	460g	-1137K	1149.00
63.5 x 76	11 x 25mm	9	710g	-1209K	1526.00
63.5 x 76	11 x 75mm	9	800g	-1239K	1653.00

Solid Steel - Anti-Pick, Anti-Cut

Hardened solid steel, chrome and duplex nickel plated body with a molybdenum alloy anti-cut changeable steel shackle. Fitted with a double locking mechanism and an anti-pick six pin brass cylinder. For indoor and outdoor use on medium to maximum security items.
Key change every 20,000.



ANTI-CUT SHACKLE



Body Width	Shackle Diameter x Clearance	Rating (1 - 10)	Weight each	Order Code MTL-950	Price/1 TB
50 x 76	9.5 x 25mm	8	400g	-2508K	1140.00
50 x 76	9.5 x 50mm	8	430g	-2528K	1172.00
50 x 76	9.5 x 75mm	8	455g	-2538K	1295.00
63.5 x 76	11 x 50mm	9	755g	-2629K	1646.00
63.5 x 76	11 x 75mm	9	800g	-2639K	1736.00

Solid Steel - Anti-Pick Shrouded

Hardened solid steel, chrome and duplex nickel plated body with a hardened changeable steel shackle. Fitted with a double locking mechanism, hardened steel cover plate and an anti-pick six pin brass cylinder. For indoor and outdoor use on medium to maximum security items.
Key change every 20,000.



Body Width	Shackle Diameter x Clearance	Rating (1 - 10)	Weight each	Order Code MTL-950	Price/1 TB
50mm	9.5 x 25mm	7	480g	-2027K	1932.00
63.5mm	11 x 25mm	9	830g	-2039K	3746.00

SITE MAINTENANCE



MATLOCK Weather-Resistant - Shrouded Shackles

Laminated steel body with hardened steel shackle, double locking mechanism and anti-pick cylinder. The PU coating makes this the most weather-resistant padlock. Ideally suitable for medium security for indoor and outdoor use in the harshest corrosive environments. For use on marine/brewery storage, haulage and warehouses etc. Available in a range of colours. All fitted with a weather-resistant key cover.



Body Width	Colour	Shackle Diameter x Clearance	Rating (1 - 10)	Order Code MTL-950	Price/1 TB
Covered Shackle					
50mm	Blue	8 x 33mm	6	-7716K	844.00
62mm	Black	10 x 30mm	8	-7728K	891.00
75mm	Yellow	11 x 34mm	9	-7759K	971.00

Weather-Resistant

Laminated steel body with hardened steel shackle, double locking mechanism and anti-pick cylinder. The PU coating makes this the most weather-resistant padlock. Ideally suitable for medium security for indoor and outdoor use in the harshest corrosive environments. For use on marine/brewery storage, haulage and warehouses etc. Available in a range of colours. All fitted with a weather-resistant key cover.



Body Width	Colour	Shackle Diameter x Clearance	Rating (1 - 10)	Order Code MTL-950	Price/1 TB
Standard					
45mm	Red	8.1 x 18mm	5	-7515K	393.00
54mm	Green	10.7 x 20mm	6	-7526K	514.00
69mm	Black	9 x 30mm	7	-7537K	593.00

Matlock Strong/Heavy Duty Padlocks

Designed to provide medium to maximum security for indoor and outdoor use on store front and factory gates, large toolchests, construction site storage etc. This heavy duty padlock has a hardened steel body, black e-coating, molybdenum shackle and 4 digit combination.



HARDENED SHACKLE



Body Width	Shackle Dia. x Clearance	No. of Dials	Order Code MTL-950	Price/1 TB
51.0mm	9.5 x 27mm	4	-8260K	1077.00
62.0mm	11.0 x 51mm	4	-8270K	1813.00

Safety Lockout Padlocks - Keyed Differently

Compact high security padlocks. Individually keyed to differ 6-pin lock which will not release the key until the shackle is closed. Non-conductive and non-sparking. Resistant to chemicals and corrosion. 6-pin precision-machined cylinder for extra security. Colour coded for easy identification with a photo-luminescent label. Each padlock is supplied boxed with one key and keyring.

Dimensions:

Body width: 20 x 42mm.

Shackle diameter x clearance: 6.5 x 38mm.



Product Number	Colour	Order Code MTL-950	Price/1 TB
LOK007	Red	-7950K	1365.00
LOK008	Yellow	-7960K	1365.00
LOK009	Green	-7930K	1365.00
LOK010	Blue	-7920K	1365.00
LOK011	Black	-7910K	1365.00
LOK012	Orange	-7940K	1365.00

SITESAFE Lockout Kit



Electrical Lockout Kit

Contains the most commonly required MCB lockouts, tags and labels required for routine checks, repairs or essential maintenance.

Contents: 1x red safety padlock. 1x non-conductive hasp. 1x MCB lockout pin in. 1x MCB lockout pin out. 1x MCB lockout pin out wide. 2x universal MCB lockout. 1x ultra-fine permanent pen. 10x DO NOT OPERATE tags.

Supplied complete in a belt bag.



18
PIECES

Number Pieces	Description	Order Code SSF-950	Price/1 TB
18	Lockout Kit	-3240K	3621.00

PRODUCTS ARE ONLY AVAILABLE VIA YOUR DISTRIBUTOR

GROUP 964 HAZARD TAPES

AVON Barrier Tape, Lane & Hazard Tape

High quality self-adhesive diagonal stripe hazard tape. High grade PVC.

Hazard Warning Tape

Conventional usage:

 For low head room, obstructions to be avoided, changes in floor levels, mobile equipment and placing around warning notices.

 For locating fire equipment, placing around prohibition and indicating inflammable areas.

 For placing around fire escapes, safety equipment, first aid posters and equipment and breathing apparatus.



Colour	Width x Length	Order Code AVN-964	Price/1 TB
White	50mm x 33m	-4020B	325.00
Yellow	50mm x 33m	-4010A	325.00
Yellow/Black	50mm x 33m	-4030C	325.00
Red/White	50mm x 33m	-4040D	325.00
Green/White	50mm x 33m	-4080H	325.00
Green	50mm x 33m	-4050E	325.00
Blue	50mm x 33m	-4060F	325.00
Black	50mm x 33m	-4070G	325.00
Red	50mm x 33m	-4090J	325.00
Yellow/Black	75mm x 33m	-4230C	500.00

Barrier Tape - Non-Adhesive

Non-adhesive hazard tape. Red and white or yellow and black diagonal stripe. (30 micron). With dispenser box.

Width: 75mm.
Length: 500m.



Colour	Order Code AVN-964	Price/1 TB
Red/White	-3750K	493.00
Yellow/Black	-3760K	493.00

KENNEDY Anti-Slip Floor Tape

Self-Adhesive Floor Tape

Provides extra traction on slippery surfaces such as hazardous floor areas, industrial machinery, playgroup apparatus, stair treads and various other potentially slippery areas. It can be used indoors or outdoors and is resistant to water, motor oil, detergents, solvents and UV light, providing a wide variety of anti-slip solutions.

Roll length: 18m.

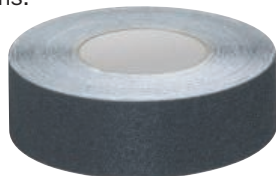

Colour	Width (mm)	Order Code KEN-964	Price/1 TB
Black	25	-2025K	335.00

BS Pipeline Marking & Identification Tape



Suitable for use at filling points, drain valves, stops and flanging points. It is recommended that pipes be clearly labelled at points where contents of the pipes could be exposed. Polypropylene coated vinyl tape for durability.

Size: 50mm x 33m.

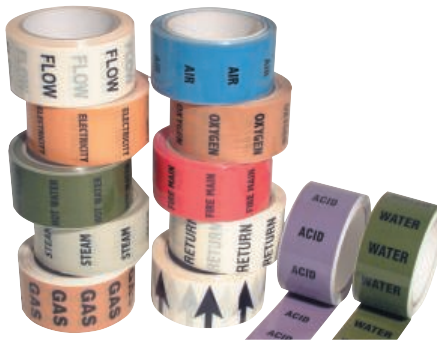

Text	Width (mm)	Order Code AVN-964	Price/1 TB
Gas	50	-2100K	617.00
Steam	50	-2110K	617.00
Water	50	-2120K	617.00
Electricity	50	-2130K	617.00
Flow	50	-2140K	617.00
Return	50	-2150K	617.00
↑ (Arrows)	50	-2160K	617.00
Air	50	-2170K	617.00
Oxygen	50	-2180K	617.00
Acid	50	-2190K	617.00
Hot	50	-2200K	617.00
Fire	50	-2210K	617.00

Magnetic Easy-Wipe Racking Strip

A flexible magnetic strip which adheres to any steel surface. Easily cut to size with a gloss vinyl surface which can be written on. For use with drywipe pens and solvent cleaner for wiping. 10m white rolls.

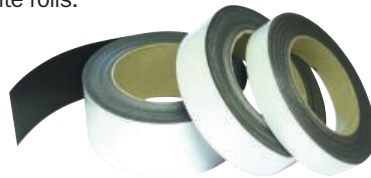

Label Size W x L	Order Code AVN-966	Price/1 TB
20mm x 10m	-0130K	954.00
30mm x 10m	-0140K	1221.00
50mm x 10m	-0150K	1860.00

Identification Tags with String

Strong, high quality tags ideal for a wide range of uses. Made from 100% recycled board. Reinforced with washers for added strength.

Available in buff, blue, green, red, white and yellow. Please note, colours are for guidance only.

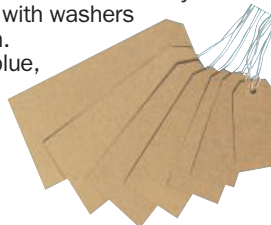

Colour	Size	Qty	Dimensions (mm)	Order Code AVN-966	Price/Pk TB
Buff	1	1000	70 x 35	-0020K	1000.00
	2	1000	82 x 41	-0030K	1191.00
	3	1000	96 x 48	-0040K	1327.00
Buff	4	1000	108 x 54	-0050K	1438.00
	5	1000	120 x 60	-0060K	1515.00
	6	1000	134 x 67	-0070K	1735.00
Blue	2	250	120 x 60	-0080K	573.00
Green	2	250	120 x 60	-0090K	573.00
Red	2	250	120 x 60	-0100K	573.00
White	2	250	120 x 60	-0110K	573.00
Yellow	2	250	120 x 60	-0120K	573.00

Anti-Slip Self Adhesive Floor Tape

Provides extra traction on slippery surfaces such as hazardous floor areas, industrial machinery, playgroup apparatus, stair treads and various other potentially slippery areas. It is designed to provide a quick, effective and economical solution to the problem with a self-adhesive back for ease of installation. It can be used indoors or outdoors and is resistant to water, motor oil, detergents, solvents and UV light, providing a wide variety of anti-slip solutions.

NEW



Size	Pack Qty	Order Code AVN-964	Price/1 TB
Black	50	-5360K	1029.00
	100	-5370K	1288.00

Anti-slip Cleats

Provides extra grip on smooth surfaces. Hard wearing, durable and easily installed. Pad size 610mm x 150mm. Supplied in black.

General Purpose

Ideal for stairways, ramps, ladders and machine footplates.



NEW

Size	Pack Qty	Order Code AVN-964	Price/1 TB
610 x 150mm	5	-5240K	926.00
	10	-5250K	2163.00

Coarse

Ideal for indoor and outdoor use.



NEW

Size	Pack Qty	Order Code AVN-964	Price/1 TB
610 x 150mm	5	-5320K	1803.00
	10	-5330K	3089.00

SITE MAINTENANCE

MATLOCK Jute Rope

6mm x 10m hank and 100m reel. No.4 type. 8 plait construction with core. 100% natural jute fibre. Resistant to heat and fire. Low stretch. Fully biodegradable. Store in a dry place. A general-purpose rope used by builders, DIY and gardeners.



Size Dia x Length	Weight each	Order Code MTL-978	Price/1 TB
6mm x 10m	185g	-5510K	205.00
6mm x 100m	1850g	-5520K	1700.00

Waxed Cotton Rope

6mm x 10m hank and 100m reel. No.4 type. 16 plait construction. Waxed for longer life. Polypropylene core for added strength. Weather-resistant. Low stretch. Smooth running. Used in the building trade and DIY for sash window repair, household refurbishment and outdoor use.



Size Dia x Length	Weight each	Order Code MTL-978	Price/1 TB
6mm x 10m	240g	-5710K	279.00
6mm x 100m	2.4kg	-5720K	2421.00

Polished Cotton Rope

6mm x 10m hank. No.8 type. Solid 12 braid construction. Centre core. 100% pure cotton. Polished finish for longer life. High abrasion resistance. Moisture-resistant. Low stretch. Used in the building trade and in the home Applications include sash window repair, industrial and domestic pulley systems.



Size Dia x Length	Weight each	Order Code MTL-978	Price/1 TB
6mm x 10m	285g	-5910K	387.00

Hi Vis Braided Cord

4mm x 100m reel. Solid 16 plait construction. Highly flexible with polypropylene for added strength and durability, weather-resistant and will float on water. Low stretch and smooth running.



Size Dia x Length	Weight each	Order Code MTL-978	Price/1 TB
4mm x 100m	600g	-6840K	1170.00

Polyester Rope

6mm x 100m reel. No.4 type. Eight plait construction. Centre core. 100% polyester. Easy to handle, knot and splice. High abrasion-resistance. Resistant to organic and mineral acids, oxidising agents and diluted alkalis. UV and weather resistant. Low stretch. A general-purpose high strength rope, suitable for repairing sash windows.



Size Dia x Length	Weight each	Order Code MTL-978	Price/1 TB
6mm x 100m	2.3kg	-5620K	3605.00

Industrial Load Straps

Load Strap Plain End

Supplied as a single strap with ratchet unit attached to one end. Tension is applied by looping the strap around the cargo and threading back through the ratchet. Designed to safely secure cargo for transport.



Product Code	Length	Min Break load	Order Code MTL-978	Price/1 TB
LS11-0.3T	2.5m	300kg	-8020K	219.00
LS05-0.8T	4.5m	800kg	-8040K	328.00
LS05-1T	4.5m	1,000kg	-8060K	438.00
LS05-0.8T	6.0m	800kg	-8080K	304.00
LS05-1T	6.0m	1,000kg	-8100K	603.00
LS05-2T	7.5m	2,000kg	-8120K	716.00
LS05-2.5T	7.5m	2,500kg	-8140K	876.00
LS05-5T	8.0m	5,000kg	-8180K	1092.00

Hook-Ended Two-Part Load Strap

Supplied as two pieces. The first strap is hooked on one end and plain on the other. The second is a shorter strap with a hook on one end and ratchet on the other. Tension is applied by looping the strap around the cargo and threading back through the ratchet. Designed to safely secure cargo for transport.



Product Code	Length	Min Break load	Order Code MTL-978	Price/1 TB
LS02-1.5T	4.0m	1,500kg	-8300K	716.00
LS02-0.8T	4.5m	800kg	-8340K	387.00
LS02-1T	4.5m	1,000kg	-8360K	603.00
LS02-1T	6.0m	1,000kg	-8380K	655.00
LS02-1.5T	6.0m	1,500kg	-8400K	820.00
LS02-3T	6.0m	3,000kg	-8420K	1041.00
LS02-2T	7.5m	2,000kg	-8440K	823.00
LS02-2.5T	7.5m	2,500kg	-8460K	1149.00
LS02-5T	8.0m	5,000kg	-8500K	1149.00
LS02-4T	9.0m	4,000kg	-8540K	1587.00
LS02-5T	9.0m	5,000kg	-8560K	1201.00
LS02-4T	10.0m	4,000kg	-8600K	1700.00
LS02-5T	10.0m	5,000kg	-8620K	1748.00

Cargo Strap

Designed and moulded of custom 'high stretch' compounded rubber (50%) with reinforced ends and heavy duty hooks. Manufactured with the graduated teardrop design at each end for added strength. Strong end hooks, zinc-plated for added rust protection.



Size Length x Width	Weight each	Order Code MTL-978	Price/1 TB
400 x 40mm	134g	-4200K	266.00

Elastic Shock Cord

Manufactured from hard-wearing and rot-proof elastic shock cord with a multi-stranded elastic core, the outer polythene cover is UV-resistant, weatherproof and heat cut and sealed to prevent fraying, for increased durability. Ideal for securing awkward items and countless other applications.



Size	Order Code MTL-978	Price/1 TB
6mm x 8m	-6560K	514.00
8mm x 8m	-6580K	850.00

Tarpaulin Cord Ball Ties

Manufactured from hard-wearing and rot-proof 5mm elastic shock cord with a multi-stranded elastic core, the outer polythene cover is UV-resistant and weatherproof for increased durability.



Size	Order Code MTL-978	Price/Pk TB
150mm (6")	-9160K	401.00
250mm (10")	-9200K	554.00

SITE MAINTENANCE

MATLOCK Welded Straight Link Chain

Often used for common everyday uses such as trailer ties and door stays as well as the handling of materials in industry. The chain has the weld placed at the side of each link of chain. A popular and versatile product. Welded chain is light and strong, ideal for general-purpose applications such as park swings, garden use, security etc. Manufactured from mild steel. Supplied in 10m length packs in boxes.

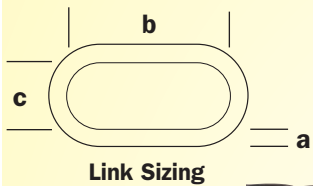

EXTENDED RANGE

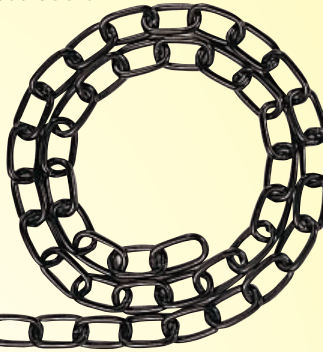

Japanned

From the ancient Japanese method of stove enamelling. Results in an attractive shiny black surface. Ideal for outdoor use.

Link Size a x b x c (mm)	Recommended Loading (kg)*	Length per Box	Weight each (kg)	Order Code MTL-978	Price/1 TB
3 x 21 x 8	50	10m	1.60	-1010K	850.00
4 x 26 x 9	85	10m	2.70	-1020K	1009.00
5 x 28 x 11	130	10m	4.70	-1030K	1486.00
6 x 33 x 13	140	10m	7.00	-1040K	1910.00
8 x 40 x 15	160	10m	9.00	-1050K	4119.00

Galvanised

Gives a high standard of corrosion resistance in all exterior environments. The thickness of the zinc coating may be variable due to the process of dipping in molten zinc. Recommended for exterior use.

Link Size a x b x c (mm)	Recommended Loading (kg)*	Length per Box	Weight each (kg)	Order Code MTL-978	Price/1 TB
3 x 21 x 8	50	10m	1.70	-1110K	903.00
4 x 26 x 9	85	10m	2.90	-1120K	1167.00
5 x 28 x 11	130	10m	5.00	-1130K	1592.00
6 x 33 x 13	140	10m	7.20	-1140K	1858.00
8 x 40 x 15	160	10m	9.30	-1150K	4635.00

Bright Zinc-Plated (BZP)

Zinc-plating involves the electrolytic application of zinc by immersing clean steel parts in a zinc salt solution and applying an electric current. This process applies a layer of pure zinc. Ideal for exterior use.

Link Size a x b x c (mm)	Recommended Loading (kg)*	Length per Box	Weight each (kg)	Order Code MTL-978	Price/1 TB
3 x 21 x 8	50	10m	1.70	-1210K	617.00
4 x 26 x 9	85	10m	2.90	-1220K	797.00
5 x 28 x 11	130	10m	5.00	-1230K	1592.00
6 x 33 x 13	140	10m	7.20	-1240K	2228.00
8 x 40 x 15	160	10m	9.30	-1250K	3605.00

Solid Brass Oval

A general purpose chain, decorative and rust resistant.

Link Size a x b x c (mm)	Finish	Length per Box	Weight each (kg)	Order Code MTL-978	Price/1 TB
1.8 x 13	Chrome	10m	0.70	-1810K	3060.00
1.8 x 13	Polished	10m	0.70	-1820K	2776.00
2.3 x 16	Chrome	10m	0.97	-1910K	4223.00
2.3 x 16	Polished	10m	0.97	-1920K	3605.00

Stainless Steel Long Link

Stainless steel marine grade for additional corrosion resistance.

Link Size a x b x c (mm)	Recommended Loading (kg)*	Length per Box	Weight each (kg)	Order Code MTL-978	Price/1 TB
3 x 26 x 6	80	10m	2.20	-2020K	3605.00
4 x 32 x 8	120	10m	3.40	-2030K	4759.00
5 x 35 x 10	160	10m	5.10	-2040K	7478.00
6 x 42 x 12	250	10m	5.82	-2050K	10403.00
8 x 52 x 16	460	10m	11.40	-2060K	19055.00

* Chains are NOT tested. Load figures are guidance only.

Mending Links

With 'scarf' opening at one end for maximum strength. Ideal for joining or repairing chains. Galvanised finish.



Size (mm)	Length (mm)	Pack Qty	Order Code MTL-978	Price/Pk TB
5	32 (1 1/4")	5	-3300K	160.00
6	38 (1 1/2")	5	-3310K	266.00
7	51 (2")	2	-3320K	106.00
8	51 (2")	2	-3330K	186.00

Cleat Hooks

Cast iron hooks generally for use with pulleys.



Length (mm)	Finish	Order Code MTL-978	Price/1 TB
75 (3")	Electro-Galv	-4620K	160.00
100 (4")	Electro-Galv	-4630K	186.00
150 (6")	BZP	-4640K	228.00

Quick Repair Links

A connection for joining lengths of chain or rope. Available in two finishes.



Link Dia. (mm)	Finish	Pack Qty	Order Code MTL-978	Price/Pk TB
3.5 (3/32")		2	-3370K	266.00
4 (5/32")		2	-3380K	170.00
5 (3/16")	Zinc	2	-3390K	250.00
6 (1/4")		1	-3400K	106.00
8 (5/16")		1	-3410K	108.00
4 (5/32")	Stainless	2	-3450K	411.00
5 (3/16")		2	-3460K	411.00
6 (1/4")	Steel	2	-3470K	514.00
8 (5/16")		2	-3480K	670.00

Heavy Duty Security Chain

Black Nylon
Hardened square links with nylon sheath for protection. For domestic and industrial applications.



Chain Length	Link Dia.	Sheath Material	Order Code MTL-978	Price/1 TB
1200mm	10mm	Nylon	-3100K	1645.00
1500mm			-3110K	3089.00

Strong Link Security Chain

Bright Zinc Plated (BZP)
Hardened links with a polypropylene moulded sheath for added protection. For domestic and industrial applications.



Chain Length	Link Dia.	Finish	Order Code MTL-978	Price/1 TB
900mm			-3200K	768.00
1200mm	8mm	BZP	-3210K	1029.00
1500mm			-3220K	1442.00

Spiked Steel Chain

Galvanised
Ornamental welded steel chain with spike every alternate link. Hot dip galvanised for maximum corrosion resistance.



Link Size (mm)	Finish	Order Code MTL-978	Price/1 TB
1500 x 8mm	Galvanised	-3020K	5149.00

S-Hooks

General-purpose hook ideal for hanging baskets etc. Galvanised finish.



Length (mm)	Pack Qty	Dia. of Material	Order Code MTL-978	Price/Pk TB
25 (1")	10	3.0mm	-3700K	212.00
38 (1 1/2")	10	4.5mm	-3710K	318.00
51 (2")	10	5.5mm	-3720K	424.00
63 (2 1/2")	5	6.3mm	-3730K	318.00
76 (3")	5	8.0mm	-3740K	346.00
100 (4")	5	10.0mm	-3750K	478.00

SITE MAINTENANCE

MATLOCK

Swivel Harness Snap Hook

A general-purpose hook ideal for keys, leashes and holdalls.



Length x Eye (mm)	Finish	Order Code MTL-978	Price/1 TB
76 x 20 (3" x 3/4")	Nickel-Plated	-4540K	478.00

Swivel Spring Billet Hook

Animal leash clips for chains, with swivel to prevent knotting and twisting.



Length (mm)	Finish	Order Code MTL-978	Price/1 TB
57 (2 1/4")	Nickel-Plated	-4510K	133.00

Ring On Plate

For tethering animals, mooring small boats, and securing equipment.



Ring x Plate (mm)	Finish	Order Code MTL-978	Price/1 TB
50 x 50 (2" x 2")	Galvanised	-4740K	239.00

Staple On Plate

A comprehensive range of accessories to suit flexible connectors, ropes and chains. For permanently fixing chain or rope to a wall, fence or post.



Staple x Plate (mm)	Finish	Order Code MTL-978	Price/1 TB
50 x 50 (2" x 2")	Galvanised	-4720K	205.00

Hook On Plate

End fitting for mounting on to fence posts or walls.



Hook x Plate (mm)	Finish	Order Code MTL-978	Price/1 TB
50 x 50 (2" x 2")	Galvanised	-4700K	191.00

Bow Shackles

A coupling link with a bow shape to allow extra clearance for more than one length of chain or rope. Material and pin diameters are equal except where stated. Rated loads are for guidance only. 'Tested' bow shackles are available to order.



Material x Pin Dia. (mm)	Finish	Order Code MTL-978	Price/1 TB
6 (1/4")	Galvanised	-4420K	165.00
10 (3/8")	Galvanised	-4440K	191.00
13 (1/2")	Galvanised	-4450K	248.00

Swivel Spring Hooks

Connectors for ropes and chains, with swivel to allow revolving and prevent knotting and twisting. Zinc plated finish.

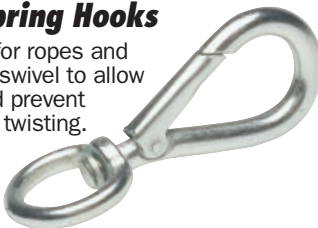

Length (mm)	Pack Qty	Order Code MTL-978	Price/Pk TB
50 (2")	2	-3500K	258.00
63 (2 1/2")	2	-3510K	266.00
75 (3")	2	-3520K	292.00
90 (3 1/2")	2	-3530K	387.00
100 (4")	2	-3540K	492.00

Commercial Thimbles

A metal loop that forms a rope eyelet to prevent wear and tear. Galvanised finish.



Length x Rope Dia. (mm)	Pack Qty	Order Code MTL-978	Price/Pk TB
25 x 3 (1" x 1/8")	4	-3800K	212.00
28 x 4 (1 1/8" x 5/32")	4	-3810K	228.00
32 x 5 (1 1/4" x 3/16")	4	-3820K	258.00
38 x 6 (1 1/2" x 1/4")	4	-3830K	372.00

Spring Hooks

A permanent end connector for chain and rope.



Length (mm)	Finish	Order Code MTL-978	Price/1 TB
50 (2")	Zinc-Plated	-3600K	160.00
63 (2 1/2")	Zinc-Plated	-3610K	232.00
75 (3")	Zinc-Plated	-3620K	266.00
90 (3 1/2")	Zinc-Plated	-3630K	292.00
100 (4")	Zinc-Plated	-3640K	346.00

Wire Rope Grips

To grip the return ends of wire rope when in a loop. For rope grips shackles supplied with certificates of conformity please.



Wire Rope Dia. (mm)	Finish	Pack Qty	Order Code MTL-978	Price/Pk TB
3 (1/8")	Galvanised	4	-5010K	160.00
5 (3/16")	Galvanised	4	-5020K	176.00
6 (1/4")	Galvanised	4	-5030K	186.00
8 (5/16")	Galvanised	2	-5040K	186.00
10 (3/8")	Galvanised	2	-5060K	196.00
13 (1/2")	Galvanised	2	-5070K	196.00

Dee Shackles

A coupling link for chain and rope with a 'D' shape to prevent excess movement. Material and pin diameters are equal except where stated. Rated loads are for guidance only - 'tested' dee shackles are available to order.



Material x Pin Dia. (mm)	Finish	Pack Qty	Order Code MTL-978	Price/Pk TB
5 (3/16")	Galvanised	4	-4320K	154.00
6 (1/4")	Galvanised	4	-4330K	176.00
8 (5/16")	Galvanised	2	-4340K	165.00
10 (7/16")	Galvanised	2	-4350K	192.00
12 (1/2")	Galvanised	2	-4360K	235.00
16 (5/8")	Galvanised	2	-4370K	387.00
4 (5/32")	St. Steel	2	-4380K	284.00
5 (3/16")	St. Steel	2	-4390K	346.00
6 (1/4")	St. Steel	2	-4400K	567.00
8 (5/16")	St. Steel	2	-4410K	593.00

Carbine Hooks

Quick release hook for connecting to chain or rope.



Di. x Length (mm)	Finish	Pack Qty	Order Code MTL-978	Price/Pk TB
5 x 50 (2")	Galvanised	2	-4120K	897.00
6 x 60 (2 3/8")	Galvanised	2	-4130K	912.00
7 x 70 (2 3/4")	Galvanised	2	-4140K	955.00
8 x 80 (3 1/2")	Galvanised	2	-4150K	971.00
10 x 100 (4")	Galvanised	2	-4160K	1051.00
4 x 40 (1 13/32")	St. Steel	2	-4180K	205.00
5 x 50 (2")	St. Steel	2	-4181K	263.00
6 x 60 (2 3/8")	St. Steel	2	-4182K	335.00
8 x 80 (3 1/2")	St. Steel	2	-4183K	411.00

Pulleys

Ideal for flagpoles, washing lines, and rolling back awning canopies. With cast wheels for ropes up to 8mm dia. Line pulleys are supplied fitted with S type hooks. Galvanised pulleys have cast wheels for rope up to 8mm dia. Black (epoxy) pulleys have nylon wheels for rope up to 8mm dia. All types below are with single wheel.

Pulley Type	Sheath Dia. (mm)	Finish	Order Code MTL-978	Price/1 TB
Awning	38 (1 1/2")	Galvanised	-3910K	452.00
Awning	38 (1 1/2")	Black	-3900K	372.00
Line	38 (1 1/2")	Galvanised	-3920K	575.00
Upright	38 (1 1/2")	Black	-3930K	438.00
Screw	44 (1 3/4")	Black	-3940K	424.00
Sash	44 (1 3/4")	Zinc Plated	-3950K	372.00



PRODUCTS ARE ONLY AVAILABLE VIA YOUR DISTRIBUTOR

GROUP 984 TARPULINS

MATLOCK *Matlock Tarpaulins*

For industry, construction, agriculture, marine, domestic and recreation. Washable, shrinkproof, rotproof, tear-resistant and UV stabilised to prevent fading. Ideal ground cover for camping, hunting or fishing.

Double-laminated polyethylene weave with rope lined hems which are heat-sealed with aluminium eyelets at one metre intervals.

Available in green or reversible blue/green.

Standard Duty:
120g with standard corners.

Heavy Duty:
160g with reinforced corners.



SITE MAINTENANCE

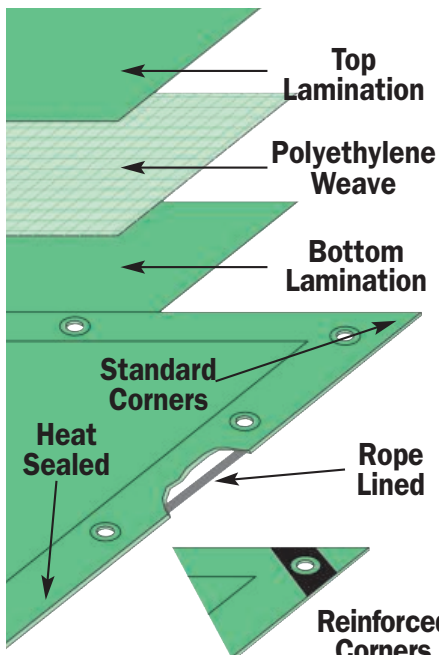

Size (m)	Order Code MTL-984 Blue/Green	Price/1 TB
Standard-Duty 120g		
2.7 x 3.6	-1020K	428.00
3.6 x 5.4	-1040K	1059.00
4.5 x 6.0	-1060K	1274.00
5.4 x 7.0	-1080K	1494.00
7.0 x 9.0	-1100K	2575.00

Size (m)	Order Code MTL-984 Green	Price/1 TB
Standard Duty 120g		
1.2 x 1.8	-5000K	102.00
1.8 x 1.8	-5010K	134.00
1.8 x 2.4	-5020K	205.00
2.5 x 3.5	-5030K	366.00
3.6 x 5.0	-5040K	773.00
3.6 x 7.0	-5050K	1029.00
4.0 x 5.0	-5060K	903.00
5.0 x 6.0	-5070K	1236.00
5.4 x 7.2	-5080K	2009.00
7.0 x 9.0	-5090K	3376.00
7.0 x 11.0	-5100K	4124.00
9.0 x 14.0	-5110K	6749.00
10.0 x 10.0	-5120K	4119.00
Heavy Duty 160g		
1.2 x 1.8	-5400K	160.00
1.6 x 2.2	-5405K	384.00
2.5 x 3.5	-5430K	652.00
3.6 x 5.0	-5440K	1298.00
3.6 x 7.0	-5450K	1490.00
4.0 x 5.0	-5460K	1490.00
5.0 x 6.0	-5470K	1700.00
5.4 x 7.2	-5480K	1962.00
7.0 x 9.0	-5490K	3605.00
10.0 x 10.0	-5520K	5408.00

MATLOCK Heavy Duty 'P' Handle Sack Truck

'P' style handle for easy handling of heavy objects. Handle design keeps truck horizontal when laid flat. All tubular steel construction. Large 250mm pneumatic wheels for stable transport over uneven or stepped surfaces. Self-assembly wheels.
Capacity: 200kg.



200kg Capacity

NEW

Capacity	Weight each	Order Code	Price/1 TB
200kg	8.8kg	MTL-985 -1610K	2059.00

Stair Climbing Sack Truck

Tubular steel with double framed sides for increased rigidity. Looped handles provide knuckle protection and positive grip in various positions. Fitted with 400mm long footiron, three star wheeling with 125mm diameter polypropylene tyred wheels for regular contact with stairs and curbs.

Height x width: 1070 x 610mm.
Capacity: 200kg.



200kg Capacity

Capacity	Order Code	Price/1 TB
200kg	MTL-985 -2020K	7066.00

Heavy Duty Sack Trucks

High quality tubular steel frame with solid rubber tyres and hand grips on the handles. Self-assembly wheels.
Capacity: 100 and 200kg.



100kg Capacity



200kg Capacity



Capacity	Colour	Weight each	Order Code	Price/1 TB
100kg	Blue	10.3kg	CTL-985 -2000D	1906.00
200kg	Red	11.7kg	-2010E	2575.00

Stair Climbing Sack Truck

Tubular steel with double-framed sides for increased rigidity. Looped handles provide knuckle protection and positive grip in various positions. Curved crossbar - suitable for carrying cylindrical items. Fitted with 255mm long foot iron which has upturned back edge. Three star wheeling with 150mm diameter rubber tyred wheels for regular contact with stairs and curbs.

Height x width: 1275 x 620mm.
Capacity: 200kg.



200kg Capacity

Capacity	Weight each	Order Code	Price/1 TB
200kg	16.5kg	MTL-985 -2000K	7320.00

SITE MAINTENANCE

GROUP 985 HANDLING

MATLOCK Folding Platform Truck

Lightweight aluminium. Ideal for delivery vans. 2x fixed and 2x 360° 100mm diameter solid rubber castors. 670 - 956mm telescopic handle. Folds flat for easy storage.

Base size: 500 x 415mm.
Capacity: 150kg.



FOLDS FLAT

Capacity	Weight	Order Code	Price/1 TB
150kg	8.00kg	MTL-985 -3360K	4646.00



Three Position Platform/Sack Truck

Large 200mm solid rubber sack truck wheels. Two 360° platform truck castors for easy manoeuvrability. Removable handle for easy storage. Flat packed for user assembly.

Capacity: 80kg.



NEW

80kg Capacity

Capacity	Weight each	Order Code	Price/1 TB
80kg	8.6kg	MTL-985 -2090K	2421.00

SITE MAINTENANCE

Folding Trolleys

Non-slip PVC load surface. Tubular steel handle folds flat for minimal storage space requirements. 2x fixed and 2x swivel castors for easy movement. PVC buffer strip on the platform edge to protect doors and furniture. Ideal for office environments.

Platform size: 616 x 916mm.
Capacities: 150 and 300kg.



FOLDS FLAT



150kg Capacity

&

300kg Capacity

NEW

Capacity	Weight	Order Code	Price/1 TB
150kg	8.5kg	MTL-985 -2030K	2163.00
300kg	15.2kg	-2060K	5408.00

Heavy Duty 3-in-1 Truck

Versatile hand truck which converts to a platform truck or 45° barrow. Fitted with two 200mm diameter solid rubber, roller bearing tyred wheels and two 125mm diameter rubber tyred swivel castors.

Height: horizontal 460mm, vertical 1250mm.
Width: 470mm.
Platform length: 1100mm.
Capacity: 350kg.



350kg Capacity



NEW

Capacity	Weight each	Order Code	Price/1 TB
350kg	22.3kg	MTL-985 -0998K	6953.00

Service Trolley

3 Shelf Trolley

Super strong polyethylene moulded. Constructed from a non-conductive material which is unaffected by battery acid, solvents and cleaning solutions.

Overall dimensions (L x W x H): 610 x 458 x 840mm.



Capacity	Order Code	Price/1 TB
150kg	MTL-985 -3220K	13905.00

MATLOCK Access Platform

Non-integrated working platform fitted with foldaway rear guard. Meets the requirements of **HSE Guidance Note PM28 (3rd Edition December 2005)**. An economical and safe way to carry out non-routine maintenance tasks. Lifts 200kg or one man with tools. Comes with rated fixed safety harness anchor point within the safety cage. Fits most forklift trucks, is manufactured from steel and finished in safety yellow.

- Specifications:**
 800 x 800mm carry basket.
 Fitted with foldaway rear guard.
 Locking fork restraint.
 Lift up front gate bar.
 Fixed anchor point.
Fork size: 170 x 70mm.



Description	Carry Basket (mm)	Weight each	Order Code	Price/1 TB
Access Platform	800 x 800	68kg	-1430A	56650.00



Pallet Trucks

Fully sealed hydraulic system with pressure relief and overload valves. Three position trigger: lift-neutral-lower. Bushed in key areas with grease points and entry/exit rollers. **National standards:** ISO3691-5:2014 and ISO3691-7:2011.

- Specification:**
Capacity: 2500kg.
Fork length: 1150mm.
Overall fork width: 550/685mm.
Fork dimension: 160 x 50mm.
Raised height: 200mm.
Lowered height: 85mm.
Steer wheels: nylon 200 x 50mm.
Load rollers: tandem - 80 x 70mm.



Capacity	Fork Size (mm)	Order Code	Price/1 TB
2500kg	1150 x 550	-1290K	30385.00
2500kg	1150 x 685	-1300K	35535.00



RUTLAND Garden Wheelbarrow
Quality Gardening Tools

Standard - suitable for all garden and domestic use. Three piece tubular steel frame. 0.7mm pressed steel pan with rolled safety edges. Plastic handles for user comfort. Green stove enamelled, corrosion-resistant easy clean finish. Pneumatic tyred disc wheel. **Capacity:** 85ltr (3cu.ft.).



Tyre Type	Weight each	Order Code	Price/1 TB
Pneumatic	13kg	-2600K	3885.00

AVON PVC Insulation Tape

Extremely flexible with a good adhesion. For wire and cable insulation, bundling and reinforcing. Assorted colours for colour-coding cables. Flame retardant. Manufactured to **BS 4J10 (Aero)** and **BS 3924**.

- Roll length:** 33m.
- Box quantities:**
19mm = 40, 25mm = 30
- Thickness:** 0.13mm (5mil).
- Adhesion:** 0.47kg/25mm, (16.5oz/1").
- Tensile strength:** 5.2kg/25mm (11.5lb/1").
- Elongation:** 150%.
- Breakdown voltage:** 5.5kV.
- Insulation class:** 80°C.



Extra Wide PVC Insulation Tape

Extremely flexible with a good adhesion. For wire and cable insulation, bundling and reinforcing. Flame retardant. Manufactured to **BS 4J10 (Aero)** and **BS 3924**.

Roll length: 33m.

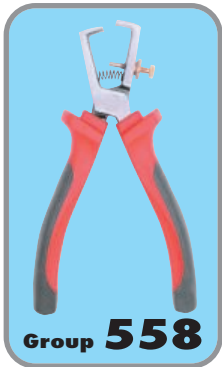

Roll Width	Colour	Box Quantity	Order Code AVN-986	Price/Roll TB
19mm	Grey	40	-7400K	85.00
	Purple	40	-7450K	85.00
	Orange	40	-7500K	85.00
	Brown	40	-7550K	85.00
	Black	40	-7600K	85.00
	Blue	40	-7650K	85.00
	Green	40	-7700K	85.00
	Red	40	-7750K	85.00
	White	40	-7800K	85.00
	Yellow	40	-7850K	85.00
25mm	Green/Yellow	40	-7950K	85.00
	Black	30	-8100K	96.00
	Blue	30	-8150K	96.00
	Green	30	-8200K	96.00
	Red	30	-8250K	96.00
	White	30	-8300K	96.00
	Yellow	30	-8350K	96.00

Roll Width	Colour	Order Code AVN-986	Price/1 TB
50mm	Black	-8500K	186.00
100mm	Black	-8700K	359.00

SITE MAINTENANCE

MATLOCK Post & Chain Barriers

The Matlock support post and chain demarcation barrier system is lightweight and sturdy. It is ideal to cordon off an area or to form a channel for queuing. Suitable for warehouses, factories, offices, leisure venues etc. Support posts, bases and chain packs sold separately.



Chain support post with cap.
Height: 910mm. **Diameter:** 50mm.



Colour	Weight	Order Code MTL-992	Price/1 TB
White/Red	380g	-2840D	384.00
Yellow/Black	380g	-2860F	384.00

Chains
Supplied in 25m lengths

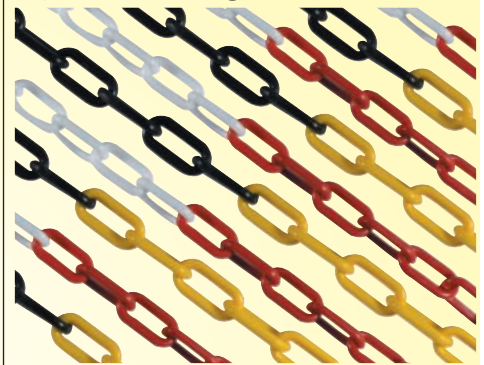

Colour	Chain Diameter	Order Code MTL-992	Price/1 TB
Red/White	6mm	-2500K	1092.00
Black/Yellow	6mm	-2510K	1092.00
Red/White	8mm	-2520K	1313.00
Black/Yellow	8mm	-2530K	1313.00
Red/White	10mm	-2540K	2023.00
Black/Yellow	10mm	-2550K	1914.00

Chain Support Post Bases



Type	Weight	Order Code MTL-992	Price/1 TB
Standard	1.9kg	-2720B	274.00
Heavy Duty	3.3kg	-2740D	547.00



Effective solution that guarantees satisfactory BARRIER CONTROL in any environment

Traditional systems for controlling people traffic using standard barriers connected via a chain or belt going pole to pole are associated with the continuous problems of maintaining a safe place to work. Even expanding barriers or self-retractable barriers could break, fall down or blow away exposing people to unnecessary and unacceptable risk. The cumbersome nature of the sturdier systems also limits their usability, making them less flexible and impairs their portability. These problems are magnified in areas that have to cope with work space restrictions and hazardous working conditions such as those found in the offshore gas and oil industry. Barriers are a key requirement of the Health and Safety (Safety Signs and Signals) Regulations. The 'Z-Barrier' system is the most innovative improvement in temporary safety barriers and provides an effective solution that

guarantees satisfactory barrier control in any work environment. 'Z-Barriers' are patent pending for the unique design that ensures barriers are prominent and remain in position, for all physical and environmental conditions. Manufactured from a unique, reinforced PVC-based double-sided warning tape, with a high visibility day glow pattern on one face and a night reflective pattern on the other face. These are the most visible barriers available on the market today. Quick and easy to put up, they are easily fastened to any anchor point or each other, providing a flexible barrier across any opening, around objects or in multiple directions. Elastic properties allow 'Z- Barriers' to expand and fit between points instead of being cut to length. They are inherently shock absorbing and resist any degree of wind load to prevent damage.



The Immediate Barrier Solution

EXTENDED RANGE

Individual Z-Barriers

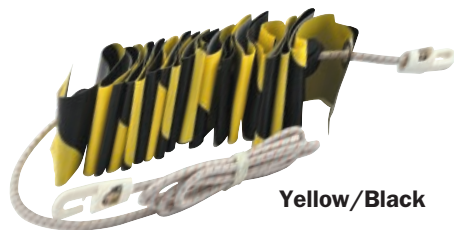

Yellow/Black

Size	Expansion Range	Order Code MTL-992	Price/1 TB
White/Red			
1	1 - 2m	-5010K	460.00
2	2 - 4m	-5020K	843.00
3	3 - 6m	-5030K	1230.00
Yellow/Black			
1	1 - 2m	-9301K	603.00
2	2 - 4m	-9302K	766.00
3	3 - 6m	-9303K	875.00

Z-Barrier Starter Pack

Contents: 10x size 1, 5x size 2 and size 3 and 2x sign pockets.

Colour	Order Code MTL-992	Price/1 TB
White/Red	-9010K	19879.00
Yellow/Black	-9322K	11475.00

Z Barrier High Visibility Heavy Duty Bag

With two shoulder straps, a carry handle and a drawstring at the top.



Description	Order Code MTL-992	Price/1 TB
Heavy Duty Bag	-3500K	7103.00

Danger
Men working overhead

Slippery floor

Strictly no admittance

No entry

A4 Sign Pockets
Internal Dimensions: 300 x 210mm.
Multiple hanging holes allow for portrait or landscape use.
Supplied with two fixing ties.

Other signs available on request, specials can be made to order.

A4 Sign Pockets (shown above)

The flexible and robust sign pockets were designed to allow users to quickly and effectively create their own signage. All you need is a pen and paper. However we do supply a range of standard signs that will fit the pockets. The most popular designs are shown here.

Description	Order Code MTL-992	Price/1 TB
A4 Sign Pockets	-7010K	863.00

SITE MAINTENANCE

PRODUCTS ARE ONLY AVAILABLE VIA YOUR DISTRIBUTOR

TUFFSAFE Fire Blankets

Fire blanket supplied in a quick release dispenser which can be attached to a wall near possible fire hazards. The blanket is manufactured from neoprene coated glass cloth. Conforms to **BS6575 1985** light duty. **B.A.F.E. approved**, Kitemarked to **BS EN1 869: 1997** and independently tested by the Loss Prevention Council. Guaranteed for five years. Unique patented 3-ply blanket material will effectively extinguish cooking oil fires.



Blanket Size	Order Code TFF-994	Price/1 TB
1.2 x 1.2m	-3000K	955.00
1.8 x 1.2m	-3020K	1433.00
1.8 x 1.8m	-3040K	1964.00

TUFFSAFE Eye Wash Station Cabinet

Wall mounted eye wash station cabinet complete with 2x 500ml eye wash solution and 2x No.16 sterile eye pads.

Weight: 2.0kg.



Group 421



Description	Order Code TFF-996	Price/1 TB
Eye Wash Cabinet	-1950K	N/A
Replacement 500ml Eye Wash Solution	-1980K	N/A

SITE MAINTENANCE

Alcohol-free Cleansing Wipes

The alcohol-free solution cleanses and soothes cuts and grazes and prepares surrounding area for dressing, ensuring greater adhesion. Individual sachets.



PACK OF 100

Pack Quantity	Order Code TFF-996	Price/Pk TB
100	-1840K	N/A

Unmedicated Dressings

High quality absorbent dressings. Medium and large dressings are sterile. Eye pad and triangular bandage are non-sterile.



Description	Size	Pk Qty	Order Code TFF-996	Price/Pk TB
Dressings	120x120mm	6	-2670K	N/A
	180x180mm	6	-2680K	N/A
Eye Pad		10	-2000K	N/A
Triangular Bandage	90x127cm	6	-2600K	N/A

Assorted Plasters

All the Tuffsafe® range of plasters are latex free, ventilated and sterile. Five different sizes (assorted) per box. Individually wrapped.



Type	Pack Size	Weight each	Order Code TFF-996	Price/1 TB
Blue - Detectable	100 assorted	125g	-2490K	N/A
Stretch Fabric	100 assorted	130g	-2510K	N/A
Waterproof	100 assorted	120g	-2530K	N/A
Fabric Extension	50 (170 x 20mm)	110g	-2560K	N/A

Safety Pins

In assorted sizes. Pack of 60.

PACK OF 60

Sizes	Order Code TFF-996	Price/Pk TB
00, 0, 1	-3000K	N/A
0, 1, 2	-3020K	N/A



TUFFSAFE Small Catering First Aid Kit

Supplied in attractive durable polypropylene blue plastic box with internal compartments for ease of access to the required dressing or treatment. Secure lids to help protect contents against dust and moisture. Wall mountable - optional hanging bracket enabling the kits to be positioned at fixed first aid points but also easily released from the wall bracket to enable it to be carried to the injured person. For up to 10 persons. Supplied in a plastic box complete with wall bracket 268 x 180 x 50mm.



Contents:

- 1x guidance card.
- 4x triangular bandages.
- 20x assorted blue plasters.
- 2x No.16 eye pads.
- 6x medium dressings 120 x 120mm.
- 2x large dressings 180 x 180mm.
- 1x face shield.
- 2x pairs latex gloves.
- 6x alcohol-free wipes.
- 1x pair tuff-cut scissors.
- 6x safety pins.
- 2x paraffin gauze pads 100 x 100mm.
- Roll of blue detectable tape.
- 30g burns cream.
- 6x blue finger stalls.

Description	Weight each	Order Code TFF-996	Price/1 TB
Small	0.8kg	-0750K	N/A

Lone Worker Kit

Essential First Aid Kit for someone working off-site or on the road.

Contents:

- 1x guidance leaflet.
- 10x adhesive plasters.
- 1x No.16 sterile eye pad.
- 2x triangular bandage.
- 6x safety pins.
- 2x medium sterile dressings 12 x 12cm.
- 1x large sterile dressing 18 x 18cm.
- 6x alcohol-free wipes.
- 1pr disposable gloves.



Description	Weight each	Order Code TFF-996	Price/1 TB
Lone Worker Kit	0.3kg	-0500K	N/A

Burns Kit

The Tuffsafe Burns Kit comes in an attractive durable polypropylene red plastic box which is associated with burns treatment. It comes complete with a comprehensive range of water-based burns dressings which soothes and moisturises the burns area by inhibiting fluid loss.

- Contents:** 1x first aid leaflet, 4x pairs disposable gloves, 1x burnshield 50ml solice, 1x heavy-duty clothing snips, 2x medium sterile dressings 12 x 12cm, 12x safety pins, 2x large sterile dressing 18 x 18cm, 4x hydrogel burn blot, 1x burnshield dressing 10 x 10cm, 2x burnshield dressing 20 x 20cm.



Description	Weight each	Order Code TFF-996	Price/1 TB
Large	120g	-0820K	N/A

Standard First Aid Kits

Suitable for the workplace.

10 Person:

For small work places up to 10 persons. Supplied in a plastic box complete with handle. 270 x 220 x 90mm.

20 Person:

For work places employing up to 20 persons. Supplied in a plastic box complete with handle. 270 x 220 x 90mm.

50 Person:

For work places employing up to 50 persons. Supplied in a plastic box complete with handle. 270 x 340 x 100mm.



50 Person Kit



20 Person Kit



10 Person Kit

Size	Order Code TFF-996	Price/1 TB
10 Person	-0710K	N/A
20 Person	-0720K	N/A
50 Person	-0730K	N/A
Refill Kits		
10 Person	-1420K	N/A
20 Person	-1430K	N/A
50 Person	-1440K	N/A



Contents Chart	10 Person	20 Person	50 Person
Guidance leaflet	1	1	1
Individually Wrapped Sterile Adhesive Plasters	20	40	60
No. 16 Sterile Eye Pad	2	4	6
Triangular Bandage	4	6	8
Safety Pins	6	12	12
Medium Sterile Dressing, 12cm x 12cm	6	9	12
Large Sterile Dressing, 18cm x 18cm	2	3	4
Alcohol Free Cleansing Wipes	6	10	20
Disposable Gloves	1 pair	2 pairs	3 pairs

SITE MAINTENANCE



GROUP 957 HEAD PROTECTION



Page **766 - 767**

GROUP 958 HEARING PROTECTION



Page **768**

GROUP 959 RESPIRATORY PROTECTION



Page **769 - 771**

GROUP 960 EYE & FACE PROTECTION



Page **772 - 777**

GROUP 961 HAND PROTECTION



Page **778 - 790**

GROUP 962 KNEE & ELBOW PADS



Page **791**

GROUP 962 FALL ARREST EQUIPMENT



Page **792 - 793**

GROUP 962 WORKWEAR



Page **795**

GROUP 962 CHEMICAL HAZARD CLOTHING



Page **799**

GROUP 962 HI-VIS CLOTHING



Page **800 - 803**

GROUP 963 SAFETY FOOTWEAR



Page **804 - 807**



PERSONAL PROTECTION

**Product Groups
957 - 963**

Product Grading



Production

High performance industrial tooling designed for continuous use applications on machine tools where repeatability and long tool life are of critical importance.



Professional

Industrial tooling that has enhanced features and benefits demanded by craftsmen and professional users.



Industrial

Designed for regular use in industrial applications. Manufactured to stringent quality levels and international standards.



Workshop

Standard quality tooling for use by tradesmen and generally industrial use.



Maintenance

Products designed for general maintenance of machines, workshops, garages and some household applications.



Home Improver

DIY quality tooling. Designed for home use and light industrial applications.

Contents

Description	Group	Page
Eye & Face Protection	960	772 - 777
Fall Arrest Equipment	962	792 - 793
Footware - Safety	963	804 - 807
Hand Protection	961	778 - 790
- Abrasion Resistant	961	786 - 787
- Chemical Resistant	961	790
- Disposable	961	790
- General Handling	961	780 - 785
- Puncture Resistant	961	789
- Tear Resistant	961	788
- Welders	961	789
Head Protection	957	766 - 767
Hearing Protection - Plugs	958	768
Knee Pads	962	791
Respiratory Protection - Masks	959	769 - 771
Supports & Knee Pads	962	791
Workwear	962	799 - 803
- Chemical Hazard	962	799
- Flame Resistant	962	799
- Food Industry	962	794
- Hi-Vis	962	800 - 802
- Waterproof	962	795

Head Protection

Offers protection from falling impact hazards such as bricks, tools and materials. It is recommended that helmets are replaced at a maximum interval of five years. This interval should be greatly reduced for helmets that have been exposed to extensive wear and tear, left in the sun, written on or have had any labels stuck on that do not have the correct adhesive. Helmets that have been damaged i.e. cut or scratched should be replaced immediately. Helmets should be regularly inspected for damage.



TUFFSAFE  **Head Protection System**

ABS Vented Safety Helmets

Vented safety helmets that have been designed with comfort, performance and style in mind. 6-point adjustable harness ensures a safe comfortable fit. Conform to: **EN 397: 1995.**



“Mix and Match” with accessories listed below or with any other PPE to create a tailored system for all applications and trades.

All items are sold separately.



8-point adjustable harness



Vented for wearer comfort

Helmet Mounted Ear Defenders

Manufactured from high quality materials and designed to be comfortable during prolonged periods of wear. For use (only) with Tuffsafe Vented Safety Helmets. Conform to: **EN 352-3: 2002. SNR: 27dB.**

Description	Colour	Order Code	Price/1 TB
Ear Defenders	Yellow	-1250K	514.00



Ear defenders, chinstrap, visor carrier and visor supplied separately.

Safety Visor

Clear, polycarbonate visor for use with Tuffsafe Visor Carrier and Vented Safety Helmets. Conforms to: **EN 166 (2001).** Optical class 1.

Size: 225mm.

Description	Order Code	Price/1 TB
Polycarbonate Visor	-2840K	372.00
Visor Carrier	-2920K	346.00

PERSONAL PROTECTION

Colour	Order Code	Price/1 TB
White	-1210K	387.00
Yellow	-1220K	387.00
Blue	-1230K	387.00
Red	-1240K	387.00
Orange	-1250K	387.00
Adjustable Chinstrap	-1940K	80.00

SITESAFE Safety Helmets

Standard+

Made of high-density injected polyethylene, the Sitesafe Standard Safety Helmet is designed to provide optimal impact protection from falling objects such as bricks and roofing tiles, as well as from electrical discharges up to 440 Vac. It comes with a fully adjustable six point harness to fit a wide range of head sizes.

Conform to:
EN 397: 2012 & EN 50365: 2002.

NEW



6-point adjustable harness

Colour	Order Code	Price/1 TB
Orange	-2040K	284.00
Red	-2050K	284.00
Royal Blue	-2060K	284.00
White	-2070K	284.00
Yellow	-2080K	284.00

RUTLAND Professional Safety Helmets

Lightweight, stable and comfortable fit with less leverage on the head and a lower centre of gravity, making it feel even lighter than it is. Short peak for enhanced visibility.

The new DeFormaTec™ system reacts ultra quickly to absorb impact energy before it reaches the wearer. The helmet shell is a result of analysis of thousands of helmet crash tests.

It is based on the same principle as a rigid yet flexible Formula 1 chassis, reacting on impact by partial deformation to absorb the shock. Fitted with a 4-point adjustable comfort webbing harness and absorbent soft leather sweatband.

Conform to **EN 397: 1996.**



Colour	Weight each	Order Code	Price/1 TB
White	325g	-0400K	514.00
Yellow	325g	-0420K	514.00

SITESAFE Helmet Accessories

For use with Sitesafe Safety Helmets
Polycarbonate Visor
225mm clear polycarbonate visor provides all round visibility whilst protecting against flying particles and liquid splash. Visor carrier supplied separately.



Description	Order Code	Price/1 TB
Visor	-9420K	464.00
Carrier	-7200K	258.00

Welder's Caps

Comfortable, durable and washable welder's caps. Double stitched construction with absorbent cotton sweat band. Can be worn with the peak to the rear when a screen is used. New improved version with taped, reinforced internal seams for extra durability and improved comfort.



Size	Weight each	Order Code	Price/1 TB
7 1/8"	35g	-5500K	438.00
7 1/4"	35g	-5510K	438.00
7 3/8"	35g	-5520K	438.00
7 1/2"	35g	-5530K	438.00
7 5/8"	40g	-5540K	438.00
7 3/4"	40g	-5550K	438.00

TUFFSAFE Baseball Bump Caps

Protects the head against accidental scraping and bumping. Absorb energy from a blow by partial destruction or damage to the shell of the cap. It is fashionable, comfortable, breathable with the twin ventilation panels and protectivemesh layer on top. Washable. Adjustable strap to fit head size 58 to 62cm. Different colours available.

Conforms to **EN 812: 2012.**



Colour	Order Code	Price/1 TB
Black	-1700K	820.00
Navy	-1740K	820.00

Baseball Bump Caps

Protects the head against accidental scraping and bumping. Energy from an impact is absorbed and dissipated by partial destruction or damage to the under shell of the cap. It is fashionable, lightweight and breathable. Reduced peak for increased upward vision, washable. Adjustable strap to fit head size 54 to 59cm. Conforms to: **EN812:2012.**



Colour	Order Code	Price/1 TB
Navy	-1800K	567.00
Red	-1801K	572.00
Royal	-1802K	572.00
Black	-1803K	572.00

PRODUCTS ARE ONLY AVAILABLE VIA YOUR DISTRIBUTOR

TUFFSAFE Disposable Ear Plugs

Premium

High protecting shaped foam ear plugs which provide maximum comfort with excellent attenuation, the smooth tapered finish makes fitting easier and helps form a comfortable fit. These ear plugs give evenly distributed pressure, flexibility and a good seal with optimum comfort. Conform to **CE 0194 EN352-2: 2002**.



PACK OF 200 PR

SNR = 37dB

Pack Quantity	Order Code	Price/Pk TB
200pr	TFF-958 -0080K	1788.00

Disposable Ear Plugs

Hexagonal foam plugs. Conform with **EN352-2: 2002**. Supplied as pairs, individually packed in polythene pouches. Tested and approved by **INSPEC**. **Box = 200 pairs**.



PACK OF 200 PR

SNR = 29dB

H = 32dB
M = 25dB
L = 20dB

Model Number	Weight per pk	Order Code	Price/Pk TB
HEP029	380g	TFF-958 -0010K	27.00

Banded Ear Plugs

Durable plastic headband equipped with soft, flexing pads adjusting to jaw and head movements. It can be worn under the chin or behind the head. Arms pivot for maximum comfort. Suitable for intermittent wear as the ear plugs do not need to be rolled to be fitted allowing easy insertion.



Can be worn under the chin or behind the head for maximum comfort

SNR = 21dB

Type	Order Code	Price/1 TB
Banded	TFF-958 -0200K	160.00

Ear Plug & Dispenser System

The dispenser is supplied with 1,000 TuffSafe® cordless earplugs (Refill order code: TFF-958-9020K). The dispenser is designed for durability and ease of use in the workplace. The ear plugs are dispensed singly simply by twisting the nozzle, the clear container allows the contents to be seen at all times helping to ensure you do not unexpectedly run out of earplugs. The dispensers can either be fixed to a wall or stood on a workbench.

Ear plug specification:

Cordless type, disposable for comfortable hearing protection without impairing normal communication. **SNR: 37dB**. Product conforms to **EN352-2: 2002**. **Nominal size:** smallest: 6, largest: 12.



SNR = 37dB

Description	Order Code	Price/1 TB
Dispenser + 1000 Plugs	TFF-958 -9010K	3631.00
Refill (1000 Plugs)	-9020K	2277.00

Corded Ear Plugs

Shaped foam corded ear plugs with red cord for maximum visibility, comfort and protection, the smooth tapered finish makes fitting easier and helps form a comfortable fit. These ear plugs give evenly distributed pressure, flexibility and a good seal with optimum comfort. Conform to **CE 0194 EN352-2: 2002**.



SNR = 37dB

Type	Order Code	Price/1 TB
Corded Ear Plugs	TFF-958 -0300K	57.00

Ear Defenders

Helmet Mounted

Manufactured from high quality materials and designed to be comfortable during prolonged periods of wear. Conform to: **EN 352-3: 2002**. **(CE, ANSI, AUS/NZ)**.

For use with Tuffsafe vented safety helmets only.



SNR = 27dB

Type	Order Code	Price/Pr TB
Ear Defenders	TFF-958	-1250K 514.00

SITESAFE Hearing Defenders

With flexible reinforced plastic headbands ABS cups and PVC cushions. Conform with **EN352-1: 2002**.



H = 33dB
M = 24dB
L = 15dB

SNR = 27dB

Duty Type	Order Code	Price/1 TB
General	SSF-958 -4040K	304.00

Folding Hearing Defenders

Hazardous Duty Type

Foldaway design with telescopic arms. Conform with **EN352-1: 2002**.



SNR = 30dB

H = 36dB
M = 28dB
L = 18dB

Duty Type	Order Code	Price/1 TB
Hazardous	SSF-958 -4080K	542.00

PERSONAL PROTECTION

RESPIRATORY PROTECTION - MASKS: FFP3

Selection of Respiratory Disposable Products

There are three types of protection standards -

- P1:** Lower or basic level - choice with/without valve.
- P2:** Intermediate - choice with/without valve.
- P3:** Highest level of protection - available only with valve. The valve reduces heat and moisture build-up which improves comfort for the wearer.

Common Respiratory Hazards

- Dusts:** Created when solid materials are totally or partially reduced to smaller particles, they are more easily inhaled the longer they stay in the atmosphere.
- Fumes:** These will generally be created when materials/metals vapourise in high temperature conditions which then cool rapidly thus condensing into very fine particles
- Gases:** Which are airborne at room temperature and are able to move about rapidly into any space within a short period of time.
- Vapour:** Are given off by materials that are generally liquids or solids at normal room temperature.

Terminology used in Respiratory Protection

- W.E.L.:** **Workplace Exposure Limits**
These are two types - occupational exposure standards or maximum exposure limits.
- O.E.S.:** **Occupational Exposure Standards**
These are levels for a substance for which the majority of employees may be exposed to for an eight hour day, five days a week. Exposure to a substance assigned as O.E.S. can be exceeded, however steps need to have been identified to show exposure will be reduced.
- M.E.L.:** **Maximum Exposure Limits**
These limits are generally accepted as the maximum exposure periods that people should be exposed to substances which can result in very serious types of cancer, occupational asthma etc. Exact safe levels of exposure cannot be identified, and caution should be used when exposed to these substances.

The M.E.L. should never be exceeded and exposure reduced to as low as is reasonably practicable whenever possible

Protection Factors for Respiratory Protection

- N.P.F.:** **Nominal Protection Factor**
These protection factors are extracted from the performance data categories of the European Standards to which all respirators are tested. These should not be used to select R.P.E.
- A.P.F.:** **Assigned Protection Factor**
These are deduced from many workplace protection factor studies as laid out in the **British Standard BS 4275**. These should be used in product selection decisions.
- R.P.E.:** **Respiratory Protective Equipment**
Each type of respiratory protective equipment has specific limitations relevant to its use and these dictate, along with the design, what type of application and conditions are best suited to each specific product.

TUFFSAFE Particulate Respirator Mask - Valved



DRV 350

For protection from high toxicity solid aerosols in concentrations up to 50 x NPF or 20 x APF, the Tuffsafe FFP3 mask is designed to provide a custom fit which is comfortable for the wearer. Polypropylene outer layer provides a smooth lining and avoids loose fibres, whilst fringe seal avoids an open layer around edges. Adjustable headstrap ensures best seal with minimum leakage. Soft nose foam and adjustable nosepiece increase wearer comfort and acceptance over extended periods of use and the mask has an exhalation valve for reducing hot air build-up. Its contour design also enables compatibility with eyewear and reduces fogging. Conforms to **EN149:2001 + A1:2009 FFP3 NR D**.

PACK OF 5

SITESAFE Valved Particulate Respirator Mask



SSDRV350

Unique design to provide very low breathing resistance. Polypropylene (PP) outer layers provide smooth lining and avoid loose fibres, fringe seal avoids open layer around the edges, adjustable headstrap ensuring the best seal with minimum leakage, contour design ensures the compatibility of glasses/goggles and reduces fogging, full facial close-cell nose foam and adjustable nosepiece ensure custom shape and increase the worker comfort and acceptance. With exhalation valve for breathing easier and reduces hot air build-up. For protection from high toxicity harmful solid and liquid aerosols. Conforms to **EN149 2001** and **AS/NZS 1716:2003** standards.

PACK OF 5



FFP3 NR D 20 x APF
50 x NPF VALVED

NEW

FFP3 50 x NPF
20 x APF VALVED

Product Number	Pack Quantity	Weight each	Order Code	Price/Pk TB
DRV350	5		TFF-959	933.00

Product Number	Pack Quantity	Weight each	Order Code	Price/Pk TB
SSDRV350	5	24g	SSF-959	876.00

PRODUCTS ARE ONLY AVAILABLE VIA YOUR DISTRIBUTOR

FFP2 NR D: The dolomite test is an optional test under norms **EN 149:2001 +A1:2009**. Those respirators which pass the dolomite clogging test are proved to provide a more comfortable fit and resist clogging for longer.

TUFFSAFE *Particulate Respirator Mask*

DRM212

Conforms to **EN149:2001 + A1:2009 FFP2 NR D**.

Combines protection against harmful workplace environmental conditions with enhanced wearer comfort. Polypropylene outer layer provides smooth lining and avoids loose fibres, whilst fringe seal avoids an open layer around edges. Adjustable headstrap ensures best seal with minimum leakage. Soft nose foam and adjustable nosepiece increase wearer comfort and acceptance over extended periods of use and contour design enables compatibility with eyewear and reduces fogging. The mask is also disposable and requires no maintenance.

Protection against concentrations up to 12 x NPF or 10 x APF in materials such as calcium carbonate, china clay, cement, cellulose, sulphur, cotton, flour, ferrous metals, vegetable oils, hardwood, glass fibres, plastic, carbon, mineral oils, quartz, aluminium, bacteria, fungi and mycobacterium tuberculosis (TB).



**PACK OF
20**

FFP2 NR D

12 x NPF

10 x APF

Product Number	Pack Quantity	Weight each	Order Code	Price/Pk TB
DRM212	20	10g	TFF-959 -2130K	850.00

Particle Respirator Mask - Valved

DRV212

Conforms to **EN149:2001 + A1:2009 FFP2 NR D**.

Combines protection against harmful workplace environmental conditions with enhanced wearer comfort. Polypropylene outer layer provides a smooth lining and avoids loose fibres, whilst fringe seal avoids open layer around edges. Adjustable headstrap ensures best seal with minimum leakage. Soft nose foam and adjustable nosepiece increase wearer comfort and acceptance over extended periods of use and the mask has an exhalation valve for reducing hot air build-up. Its contour design also enables compatibility with eyewear and reduces fogging.

Protection against concentrations up to 12 x NPF or 10 x APF in materials such as calcium carbonate, china clay, cement, cellulose, sulphur, cotton, flour, ferrous metals, vegetable oils, hardwood, glass fibres, plastic, carbon, mineral oils, quartz, aluminium, bacteria, fungi and mycobacterium tuberculosis (TB).



**PACK OF
10**

FFP2 NR D

12 x NPF

10 x APF

VALVED

Product Number	Pack Quantity	Weight each	Order Code	Price/Pk TB
DRV212	10	17g	TFF-959 -2135K	617.00

SITESAFE *Particulate Respirator Mask*

SSDRM212

Conforms to **EN149 2001 FFP2 and AS/NZS 1716:2003**.

Features polypropylene (PP) outer layers providing smooth lining and avoiding loose fibres, whilst the fringe seal avoids open layer around the edges. Kept in position by a latex-free synthetic rubber head strap. The contour design enables the mask to be worn with glasses/goggles and the close fit helps to reduce fogging. Soft close-cell nose foam and adjustable nosepiece ensures custom shape and increases worker comfort and acceptance.

For protection against low-to-average toxicity, harmful solid, liquid and smoke in concentrations up to 12 x NPF or 10 x APF.



**PACK OF
20**

FFP2 NR

12 x NPF

10 x APF

Product Number	Pack Quantity	Weight each	Order Code	Price/Pk TB
SSDRM212	20	10g	SSF-959 -2768D	814.00

Particulate Respirator Mask - Valved

SSDRV212

Conforms to **EN149 2001 FFP2 and AS/NZS 1716:2003**

standards. Features polypropylene (PP) outer layers providing smooth lining and avoiding loose fibres, whilst fringe seal avoids open layer around edges. Kept in position by latex-free synthetic rubber head strap. Contour design enables mask to be worn with glasses/goggles and the close fit helps to reduce fogging. Soft close-cell nose foam and adjustable nosepiece ensure custom shape and increase worker comfort and acceptance. With exhalation valve for breathing easier and reduce hot air build-up.

For protection against low-to-average toxicity harmful solid, liquid and smoke in concentrations up to 12 x NPF or 10 x APF.



**PACK OF
10**

FFP2 NR

12 x NPF

10 x APF

VALVED

Product Number	Pack Quantity	Weight each	Order Code	Price/Pk TB
SSDRV212	10	17g	SSF-959 -2788D	656.00

FFP1 NR D: The dolomite test is an optional test under norms **EN 149:2001 +A1:2009**. Those respirators which pass the dolomite clogging test are proved to provide a more comfortable fit and resist clogging for longer.

TUFFSAFE Particulate Respirator Mask

DRM104
Conforms to **EN149:2001 + A1:2009 FFP1 NR D**. Combines protection against harmful workplace environmental conditions with enhanced wearer comfort. Polypropylene outer layer provides smooth lining and avoids loose fibres, whilst fringe seal avoids an open layer around edges. Adjustable headstrap ensures best seal with minimum leakage. Soft nose foam and adjustable nosepiece increase wearer comfort and acceptance over extended periods of use and contour design enables compatibility with eyewear and reduces fogging. The mask is also disposable and requires no maintenance.



PACK OF 20

FFP1 NR D 4 x NPF 4 x APF

Product Number	Pack Quantity	Weight each	Order Code	Price/Pk TB
DRM104	20	8g	-2120K	747.00

Particulate Respirator Mask

DRV104
Conforms to **EN149:2001 + A1:2009 FFP1 NR D** standards. Collapse-resistant double shell, made to withstand hot and humid conditions, a fringe seal avoids open layers around the edges, a latex-free synthetic rubber head strap and contour design ensures the mask can be worn with glasses/goggles the close fit helps to reduce fogging. Fitted with an exhalation valve for extra comfort in hot and demanding conditions allowing easy breathing and speaking. Soft close-cell nose foam and adjustable nosepiece for a custom shaped fit, increases the worker comfort and acceptance over extended periods of use.



PACK OF 10

FFP1 NR D 4 x NPF 4 x APF VALVED

Product Number	Pack Quantity	Weight each	Order Code	Price/Pk TB
DRV104	10	14g	-2125K	608.00

SITESAFE Particulate Respirator Mask

SSDRM104
Conforms to **EN149 2001 FFP1** standards. **AS/NZS 1716:2003**. Features polypropylene (PP) outer layers providing smooth lining and avoiding loose fibres, whilst the fringe seal avoids open layer around the edges. Kept in position by a latex-free synthetic rubber head strap. The contour design enables the mask to be worn with glasses/goggles and the close fit helps to reduce fogging. Soft close-cell nose foam and adjustable nosepiece ensures custom shape and increases worker comfort and acceptance. For protection against low to average toxicity harmful solid and liquid in concentrations up to 12 x NPF (Nominal Protection Factor) or 10 x APF (Assigned Protection Factor).



PACK OF 20

FFP1 4 x NPF 4 x APF

Product Number	Pack Quantity	Weight each	Order Code	Price/Pk TB
SSDRM104	20	8g	-2765K	711.00

Particulate Respirator Mask

SSDRV104
Conforms to **EN149 2001 FFP1** and **AS/NZS 1716:2003** standards. Provides protection against non-toxic harmful solid and liquid in concentrations up to 4 x NPF or 4 x APF, such as calcium carbonate, china clay, cement, cellulose, sulphur, cotton, flour, carbon, ferrous metals, vegetable oils and soft wood. Recommended applications for textile industry, craftwork, iron and steel industry, mining, woodworking etc. Exhalation valve to reduce hot air build-up. Maintenance-free (disposable).



PACK OF 10

FFP1 4 x NPF 4 x APF

Product Number	Pack Quantity	Weight each	Order Code	Price/Pk TB
SSDRV104	10	14g	-2785K	603.00

'Nuisance' Dust Mask Application Information

Nuisance dust masks should not be used to protect your lungs, or used where a device complying with the European Directive 89/686 or 89/656 is required. It is not classified as a respiratory protective device and falls outside the PPE (EC Directive) Regulations. These products should not be used to protect against fine dust particles, toxic gases and vapours.

SITESAFE Nuisance Dust Mask

SSTCM50
Reduces discomfort caused by non-toxic nuisance dusts. It is lightweight and comfortable to wear and completely maintenance-free (disposable).



PACK OF 50













Product Number	Pack Quantity	Weight each	Order Code	Price/Pk TB
SSTCM50	50	8g	-7250K	284.00



PERSONAL PROTECTION

Quick Reference

Through the eye and face protection range, there are a number of quick reference logos to help you choose which level of safety is right for you. Below are the logos and their meanings.

-  Adjustable frames for a superior fit.
-  Wrap around single lens provides unobstructed field of vision.
-  Resistant to flames and heat - not flame-proof.
-  Designed to minimise dust contamination.
-  Polycarbonate lenses are more impact-resistant and lighter than most types of lens.
-  Has a lower impact energy rating and is more flexible compared to polycarbonate.
-  This provides increased safety, while retaining excellent visibility.
-  Gives a level of protection against harmful UV rays.
-  Extended brow guard moulded into the top of the lens gives a near perfect orbital seal against debris.
-  For greater protection from debris towards the side of the eyes.
-  Glasses which have a larger lens to cover the cheek bone.
-  Resistant to chemical splashes - not chemical proof.
-  Hard coated for excellent durability and scratch resistance resulting in unobstructed viewing.

SITESAFE Anti-Fog Safety Spectacles

Saturn
One-piece clear polycarbonate lens with anti-mist treatment. Lightweight black nylon frame with built-in brow guard. Built-in side protection with integral nose bridge and adjustable temple length. Low energy impact protection with 400nm UV protection. Hang cord attachment points. Class 1.

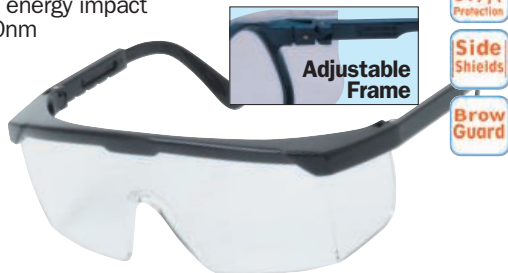

- 
- 
- 
- 
- 
- 

CE EN166 F			
Lens Type	Frame Colour	Order Code	Price/1 TB
Clear	Black	SSF-960 -7610K	160.00

Anti-Fog Safety Spectacles

Voyager
Two piece clear polycarbonate lenses with anti-mist treatment. Built-in brow guard and side shields with integral nose bridge. Low energy impact protection with total UV protection. Class 1.



- 
- 
- 
- 
- 

CE EN166 F			
Lens Type	Frame Colour	Order Code	Price/1 TB
Clear	Black	SSF-960 -8200K	191.00

Anti-Fog Safety Spectacles

Apollo
One piece amber tinted polycarbonate lens with anti-mist treatment and ultra lightweight design (26g). Built-in side protection with soft silicone nose bridge and adjustable temple length. Low energy impact protection with total UV protection. Hang cord attachment points. Class 1.



- 
- 
- 
- 
- 

CE EN166 F			
Lens Type	Frame Colour	Order Code	Price/1 TB
Amber tinted	Black	SSF-960 -5200K	155.00

KENNEDY Anti-Scratch/Anti-Fog Safety Spectacles

Panther
Low energy impact protection. Ultra light anallergenic frame with low friction length adjustment at the temples and front angle adjustment. Class 1 optical quality. Arms have hang cord attachment points.



- 
- 
- 
- 
- 

CE EN166 F IS1708			
Lens Type	Frame Colour	Order Code	Price/1 TB
Anti-Scratch/Fog	Black	KEN-960 -8010K	275.00

Over Spectacles

Aurora
Totally polycarbonate over spectacles with built-in side shields and brow guard and no metallic parts. Low energy impact protection at extreme environmental temperatures with UV protection. Can be worn over most glasses. Hang cord attachment points. Class 1.

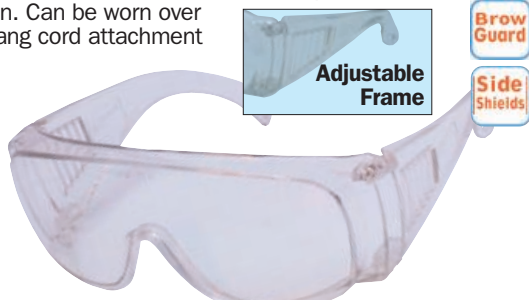

- 
- 
- 
- 

CE EN166 F			
Lens Type	Frame Colour	Order Code	Price/1 TB
Clear	Clear	SSF-960 -0800K	93.00

Scratch Resistant Safety Spectacles

Viper
UV protection against electrical arc discharges caused by a short circuit.



- 
- 
- 
- 

CE EN166 F			
Lens Type	Frame Colour	Order Code	Price/1 TB
Clear	Blue	KEN-960 -8050K	235.00

PERSONAL PROTECTION



Pacific Blue Spectacles

9212 CLEAR

The spectacles provide low energy impact protection (medium in AUS/NZ) whilst the ultra lightweight design and rubber end tips and nose bridge offer enhanced user comfort. Class 1 optical quality for distortion-free continuous use, the wide angle lens is scratch resistant and anti-mist treated.



NEW

- Scratch Resistant
- Wrap Around
- Side Shields
- Polycarbonate Lens
- Anti-fog

Lens Type	Frame Colour	Order Code	Price/1 TB
Clear	Blue	TFF-960	205.00

Pacific Black Spectacles

9212 SMOKE

Providing low energy impact protection (medium in AUS/NZ), the spectacles feature a wide angle lens which is tinted for reduced glare, as well as scratch resistant and anti-mist treated. The ultra lightweight design, combined with rubber end tips and nose bridge, enhances user comfort and the lens delivers Class 1 optical quality for distortion-free continuous use.



NEW

- Scratch Resistant
- Wrap Around
- Side Shields
- Polycarbonate Lens
- Anti-fog

Lens Type	Frame Colour	Order Code	Price/1 TB
Smoke	Black	TFF-960	205.00



Anti-Fog Safety Spectacles

Luna

One piece clear polycarbonate lens with anti-mist treatment and ultra lightweight design (26g). Built-in side protection with integral nose bridge adjustable temple length and lens inclination. Low energy impact protection with total UV protection. Hang cord attachment points. Class 1.



CE EN166 F

- Adjustable Frame
- Wrap Around
- Polycarbonate Lens
- Anti-mist
- UV Protection

Lens Type	Frame Colour	Order Code	Price/1 TB
Clear	Black	SSF-960	158.00

Anti-Fog Safety Spectacles

Mercury

One-piece clear polycarbonate lens. Lightweight black nylon frame with built-in brow guard. Integral nose bridge and adjustable temple length. Low energy impact protection. Class 1.



Adjustable Frame

- Adjustable Frame
- Polycarbonate Lens
- Anti-fog
- UV Protection
- Brow Guard
- Side Shields

CE EN166 F

Lens Type	Frame Colour	Order Code	Price/1 TB
Clear	Black	SSF-960	181.00

Clear Anti Fog Scratch Resist Safety Glasses

Sirius

Eye and Face Protection products are designed to offer users a winning mix of safety and comfort across a range of working environments and situations.



NEW

- Anti-fog
- Wrap Around

Lens Type	Frame Colour	Order Code	Price/1 TB
Clear	Black	SSF-960	150.00



Oberon Blue Spectacles

Featuring a one-piece clear polycarbonate lens with built-in side protection for added safety, these spectacles provide protection from low energy impact (medium in AUS/NZ) and UV radiation below 380nm. The incorporation of rubber end tips and nose bridge into the ultra lightweight design improves user comfort and the lens is scratch resistant and anti-mist treated with Class 1 optical quality for distortion-free continuous use.



NEW

- Anti-fog
- Scratch Resistant
- Polycarbonate Lens
- Wrap Around

Frame Colour	Order Code	Price/1 TB
Blue/Black	SSF-960	181.00

GROUP 960 EYE & FACE PROTECTION

TUFFSAFE Over Spectacles with Adjustable Frame

One piece clear polycarbonate lens with built in side protection for added safety. Anti-fog treatment on both sides of the lens. Integral nose bridge for user comfort. Lightweight for comfort.



NEW

Lens Type	Frame Colour	Order Code	Price/1 TB
Clear	Black	TFF-960	129.00

Safety Spectacles

Star
Wide angle lens and impact protection at extreme temperatures. Scratch resistant. Ultra lightweight design. Anti-mist treatment. Class 1 optical quality for distortion-free continuous use. Rubber end tips and nose bridge for user comfort. Neck lanyard included.



Lens Colour	Model	Order Code	Price/1 TB
Clear	Star	TFF-960	186.00



SITESAFE Anti-Fog Safety Spectacles

Europa
Two-piece black polycarbonate wrap around lenses providing low energy impact protection, total UV protection, an anti-fog coating. The ultra lightweight high strength frame has a soft silicone nose bridge and adjustable temple length to ensure user comfort. Hang cord attachment points. Class 1.



Frame/Lens Colour	Model	Order Code	Price/1 TB
Black	Europa	SSF-960	191.00



Scratch Resistant Safety Spectacles

Black one-piece design with wrap around scratch resistant lenses giving low impact protection and UV protection for outdoor use. Class 1.



Frame/Lens Colour	Model	Order Code	Price/1 TB
Black	Astrid	SSF-960	181.00
Yellow	Cassini	-7820K	155.00



SITESAFE Safety Spectacles

Andromeda
Single clear wrap around polycarbonate lens, scratch resistant, low impact protection and UV protection.



Lens Colour	Model	Order Code	Price/1 TB
Clear	Andromeda	SSF-960	129.00



Scratch Resistant Safety Spectacles

One-piece wrap around polycarbonate spectacle which is light in weight and features hard coated anti-fog and scratch resistant lenses.



Frame/Lens Colour	Model	Order Code	Price/1 TB
Clear	Zenith	-8400K	277.00
Yellow	Mir	-8420K	140.00



PERSONAL PROTECTION

EYE & FACE PROTECTION

TUFFSAFE Anti-Fog Safety Goggles

XL21
Safety goggles with clear single-piece polycarbonate lens and anti-mist coating. Mounted in a PVC housing with easy flow indirect ventilation and adjustable elasticated strap.



CE EN166

Mechanical Strength F

Description	Frame Colour	Order Code	Price/1 TB
Goggles	Clear	TFF-960	464.00

SITESAFE Anti-Fog Safety Spectacles

Challenger
Two-piece clear polycarbonate lens with anti-mist treatment and ultra lightweight design (26g). Built-in side protection with soft silicone nose bridge and adjustable temple length. Low energy impact protection with total UV protection. Hang cord attachment points. Class 1.



CE EN166 F

Lens Type	Frame Colour	Order Code	Price/1 TB
Clear	Black	SSF-960	185.00

KENNEDY Soft Spectacle Case & Spectacle Neck Cord

Case: Soft spectacle case with spring opening.
Neck Cord: Spectacle neck cord with adjustable side buckle.

Type	Order Code	Price/1 TB
Soft Spectacle Case	KEN-960	205.00
Spectacle Neck Cord	-9620K	151.00

SITESAFE Safety Goggles

Designed to protect the wearer from eye injury against moderate unspecified mechanical impact hazards. Anti-dust and impact resistant. Direct ventilation.



CE EN166

Optical Class 1
Mechanical Strength B

Frame Colour	Weight each	Order Code	Price/1 TB
Green	70g	SSF-960	155.00

Chemical Splash Resistant, Anti-Dust Safety Goggles

Anti-'chemical-splash' and impact resistant. Designed to protect the wearer from eye injury against moderate unspecified mechanical impact hazards and liquid splash. Indirect ventilation.



CE EN166

Optical Class 1
Mechanical Strength B

Frame Colour	Weight each	Order Code	Price/1 TB
Green	80g	SSF-960	170.00



PERSONAL PROTECTION

PRODUCTS ARE ONLY AVAILABLE VIA YOUR DISTRIBUTOR

KENNEDY *Scratch Resistant/ Anti-Fog Safety Goggles*
QUALITY INDUSTRIAL TOOLING

All goggles have a wide field of vision, built-in brow and cheek protection, soft PVC frame with an anatomically shaped bridge to adapt to all faces. All lenses provide UV protection. All frames will protect against liquid droplets and/or splashes. Fitted with wide anallergic elastic headbands and a one-piece replaceable scratch resistant, anti-mist clear lenses.

Tiger
 Medium energy impact protection. Smoke coloured frame with a polycarbonate lens and are lined with soft foam for user comfort and increased adherence. The lens is resistant to molten metals and hot solids (splashes of molten metals and penetration of hot solid). The frame has an indirect ventilation system and is resistant to liquids (drops and splashes) and penetration of hot solids.



Lens Type (Scratch resistant)	Frame Colour	Order Code KEN-960	Price/1 TB
Polycarbonate	Smoke	-8140K	699.00

Clear framed goggles are resistant to gross particles (dust particles >5 microns) and gas and fine particles (gas vapours, splashes, smokes and dust particles <5 microns).

Scorpion
 Medium energy impact protection. Clear frame with a 2mm thick polycarbonate lens. The lens and the frame is resistant to molten metals and hot solids (splashes of molten metals and penetration of hot solids).

Lion
 Low energy impact protection at extreme temperatures. Clear frame with an extremely flexible acetate lens.



CE
 EN166
 EN170

Wide Headband

Type	Lens (Scratch resistant)	Frame Colour	Order Code KEN-960	Price/1 TB
Scorpion	Polycarbonate	Clear	-8070K	450.00
Lion	Acetate	Clear	-8080K	550.00

- Polycarbonate Lens
- Anti-fog
- Cheek Guard
- UV Protection
- Scratch Resistant

Anti-Gas/Flame Resistant Safety Goggles

Condor
 Medium energy impact protection. Suitable for foundry work. The frame, lens and elastic strap are manufactured from flame resistant material. Fitted with a flexible nose bridge to adapt to all faces. Large peripheral viewing area. One piece 2mm anti-mist, scratch resistant, clear polycarbonate lens with an extra wide elastic headband. Can be fitted over most prescription glasses. The frame is resistant to liquids (drops and splashes), gross particles (dust particles >5 microns), gas and fine particles (gas vapours, splashes, smokes and dust particles <5 microns and molten metals and hot solids (splashes of molten metals and penetration of hot solids).

- Flame Resistant
- Polycarbonate Lens
- Anti-fog
- Scratch Resistant



CE
 EN166 F

Lens Type	Frame Colour	Order Code KEN-960	Price/1 TB
Scratch Resistant	Red	-8130K	899.00
Spare Lens		-8120K	350.00

Scratch Resistant/Anti-Fog Safety Goggles

Cobra
 Low energy impact protection at extreme temperatures. UV protection against electrical arc discharges caused by a short circuit. Ultra light nylon frame with length adjustment the temples and front angle adjustment for low friction, lined with soft foam for user comfort and increased adherence. One-piece, scratch resistant, anti-mist clear polycarbonate lens. As well as the arms having hang cord attachment points, a black universal hang cord is included with the goggles. Resistant to liquids (drops and splashes) and gross particles (dust particles >5 microns).

- Polycarbonate Lens
- Anti-fog
- UV Protection
- Scratch Resistant



CE
 EN166 FT

Lens Type	Frame Colour	Order Code KEN-960	Price/1 TB
Scratch Resistant	Blue	-8060K	599.00

PERSONAL PROTECTION

EYE & FACE PROTECTION

TUFFSAFE Safety Screen - Complete

Clear full face screen with high impact polycarbonate browguard, adjustable harness and replaceable sweatband. Clear polycarbonate face screen.



EN166

Optical Class 1
Mechanical Strength B

Description	Order Code	Price/1 TB
Safety Screen - Complete	-1510K	1365.00

Accessories

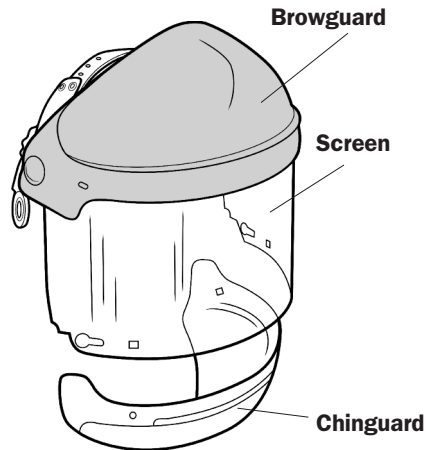

EN166

Optical Class 1
Mechanical Strength B

Description	Order Code	Price/1 TB
Screens - 200mm		
Clear	-2500K	670.00
Green/Clear, Shade 3, Tritherm	-3200K	3089.00
Chinguard	-2518K	632.00
Chinguard and Screen Complete	-2512K	1391.00
Clear Screen for Chinguard 160mm	-2514K	644.00

SITESAFE Face Guard

Replaceable one-piece clear polycarbonate lens which protects against chemical splashes, lens also has an aluminium edge. Built-in foam sweatband with a variable setting on the crown support and a ratchet controlled headband adjuster with a pivoting full face and brow protection. Medium energy impact protection Class 1.



Lens Type	Order Code	Price/1 TB
Clear	-9200K	411.00
Replacement Lens	-9220K	277.00

KENNEDY Large View Welding Helmets

Durable, lightweight material is corrosion resistant and flame retardant. External sensitivity control provides clear vision both prior and during welding. Ultra high performance filters protect against UV and IR. Auto darkening lens automatically changes from light to dark shade when arc is struck. Special turnover headband mechanism offers greater comfort and reduces fatigue. Suitable for all kinds of welding types, including Tig low amperage welding, and can be used for grinding. High impact glass for increased safety. Dual powered: Solar and battery. Complies with **DIN, ISO, EN379** safety standards and **ANSI Z 87.12** standards

- View Field:** 98 x 55mm
- UV/IR protection:** DIN16
- Light State:** DIN4
- Variable Shade:** DIN9 - DIN13
- Reaction Time:** 0.00005 Sec
- Delay Time:** 0.3 Sec - 0.9 Sec
- Sensors:** Four infrared detectors
- Power Supply:** Solar cells + CR2450 lithium battery (supplied PAN-904-2550K)
- Power:** On/Off Fully Automatic
- Operating temperature:** -5°C - 55°C (23°F - 131°F)
- Storing temperature:** -20°C - 70°C (-4°F - 158°F)



More Welding Helmets and Shields on Page 712



Light to dark
0.5 milliseconds

Pattern	Order Code	Price/1 TB
Plain Black	-5100K	4775.00
Union Jack	-5120K	4775.00

PRODUCTS ARE ONLY AVAILABLE VIA YOUR DISTRIBUTOR

PERSONAL PROTECTION

Hand Protection

The wearing of hand protection in hazardous areas is a requirement under regulation 4 of the personal protective equipment at work regulations 1992. This regulation requires employers to provide suitable personal protective equipment to employees exposed to health and safety risks. Gloves protect your hands from hazards such as burns, freezing, electrocution, abrasions, contusions, lacerations and skin complaints such as dermatitis. Gloves should be checked regularly inside and out for any contamination and wear as this can reduce the protection rating of the glove below the standard given. We recommend regular replacement as the best form of protection.

Glove Standards & Types

Simple Design (Category 1)

Gloves with this designation offer protection against light cuts, contusions, abrasions and mild detergents. Suitable for areas of 'minimal risk' where the effects on hands without gloves would be easily reversible or superficial. These products are unmarked and self-certified.

Intermediate Design (Category 2)

Gloves with this designation offer protection against heavier cuts, contusions, abrasions, tears and punctures. Suitable for areas of specific risk: abrasion, blade cuts, tear and puncture. The performance of the glove against these risks is listed below the symbol as shown below.

Complex Design (Category 3)

For areas/applications that can seriously or irreversibly harm the health. Such products, in addition to the CE type test, will also have to be either produced under an approved quality system OR be typed tested on an annual basis.

BS EN388 Mechanical Hazard Gloves

Mechanical hazards are associated with handling rough or sharp objects that could damage skin such as brick, concrete, glass, and sheet metal. Mechanical hazards are not associated with moving machinery. Gloves can be a hazard if there is a possibility they could snag in moving parts and put the user in danger.

Abrasion Resistant Gloves

- 
- a) Abrasion resistance. Scale 1 (low) to 4 (high).
 - b) Cut resistance. Scale 1 (low) to 5 (high).
 - c) Tear resistance. Scale 1 (low) to 4 (high).
 - d) Puncture resistance. Scale 1 (low) to 4 (high).
- 0 = Fail. X = No test carried out.

Each Abrasion Resistant glove has a rating - the higher the number, the greater the protection.



Cut Resistant Gloves.

- 
- a) Abrasion resistance. Scale 1 (low) to 4 (high).
 - b) Cut resistance. Scale 1 (low) to 5 (high).
 - c) Tear resistance. Scale 1 (low) to 4 (high).
 - d) Puncture resistance. Scale 1 (low) to 4 (high).
- 0 = Fail. X = No test carried out.

Each Cut Resistant glove has a rating - the higher the number, the greater the protection.



Tear Resistant Gloves

- 
- a) Abrasion resistance. Scale 1 (low) to 4 (high).
 - b) Cut resistance. Scale 1 (low) to 5 (high).
 - c) Tear resistance. Scale 1 (low) to 4 (high).
 - d) Puncture resistance. Scale 1 (low) to 4 (high).
- 0 = Fail. X = No test carried out.

Each Tear Resistant glove has a rating - the higher the number, the greater the protection.



Puncture Resistant Gloves

- 
- a) Abrasion resistance. Scale 1 (low) to 4 (high).
 - b) Cut resistance. Scale 1 (low) to 5 (high).
 - c) Tear resistance. Scale 1 (low) to 4 (high).
 - d) Puncture resistance. Scale 1 (low) to 4 (high).
- 0 = Fail. X = No test carried out.

Each Puncture Resistant glove has a rating - the higher the number, the greater the protection.



BS EN374 Chemical Hazard Gloves

Gloves with this designation offer protection against chemical splash, immersion and micro organism hazards. With the wide variety of chemicals used in today's industries any doubt with the suitability of gloves contact your local branch.



A 'Chemical Resistant' glove with a breakthrough time greater than 30 minutes. The identification letters of 3 chemicals against which the glove was tested will also appear next to the EN number.



A 'Low Chemical Resistant' glove that has failed to achieve the 30 minute breakthrough time. No chemical identification letters are shown.



Micro Organism

BS EN511 Thermal Hazard (Cold) Gloves

Gloves with this designation offer protection against convective and contact cold hazards.

- 
- a) Convective cold resistance. Scale 0 (low) to 4 (high).
 - b) Contact cold resistance. Scale 0 (low) to 4 (high).
 - c) Water permeability resistance. Scale 0 (low) to 4 (high).
- a. b. c. 0 = Fail. X = No test carried out.

BS EN407 Thermal Hazard (Heat) Gloves

Gloves with this designation offer protection against fire, contact heat, convective heat, radiant heat and molten metal.

- 
- a) Burning behaviour resistance. Scale 0 (low) to 4 (high).
 - b) Contact heat resistance. Scale 0 (low) to 4 (high).
 - c) Convection heat resistance. Scale 0 (low) to 4 (high).
 - d) Radiation heat resistance. Scale 0 (low) to 4 (high).
 - e) Small splash molten resistance. Scale 0 (low) to 4 (high).
 - f) Large quantity molten resistance. Scale 0 (low) to 4 (high).
- a.b.c.d.e.f. 0 = Fail. X = No test carried out.

Contact Heat Test

A sample is taken from the palm of the glove. The outside of the glove is put on a hot surface and the temperature of the inside of the glove is monitored. The temperature on the inside of the palm sample must not rise by more than 10°C above room temperature for a minimum of 15 seconds.

Performance Scale	Contact temperature	Threshold time
1	100°C	>15 Seconds
2	250°C	>15 Seconds
3	350°C	>15 Seconds
4	500°C	>15 Seconds





















Food Symbol



Products that carry the food contact symbol are suitable for use with all food categories (Dry foods, aqueous foods, acidic foods, alcoholic foods and fatty foods). This has been established through conducting tests according to the draft European Standards for food contact migration **DD ENV 1186** series.

Quick Reference

Through the hand protection range, there are a number of quick reference logos to help you choose which level of safety is right for you. Below are the logos and their meanings.

-  Material is resistant to abrasions for greater protection.
-  Offers protection against the level of voltage.
-  Open backed gloves provide extra ventilation to the hand keeping it cooler throughout long periods of use.
-  Offers extra protection against low impact on the base of the wrist.
-  Added surface to provide extra grip during application.
-  Help prevent and relieve pain associated with RSI (repetitive strain injury).
-  Resists the build-up and conductance of static electricity. Of most benefit when walking on synthetic carpets or near electrical machinery.
-  Handling intermittently hot objects and materials in high-heat environments.
-  Offers extra protection against low impact on the wrist or forearm.
-  Designed to protect hands from refuse which may contain needles and glass.
-  Added surface to provide exceptional grip during application.
-  Designed to protect hands from direct contact with sharp edges such as glass, metal, ceramics and other materials.
-  Chemical resistant gloves for reducing the exposure of our hands to hazardous materials.
-  Glove is made from heavier material for greater wear and tear.
-  Designed for use where vibration can cause extreme and permanent damage to the hands.
-  Offers extra insulation protection against cold objects.
-  Protective impact resistant gloves protect effectively the palms and wrists against traumatic impacts.
-  Designed to protect the hand against sharp objects piercing the glove.
-  Designed to protect hands from direct contact with sharp edges such as glass, metal, ceramics and other materials.
-  Used for inspection lines, can be made from lint-free material for less contamination.

Glove Sizing

No two hands are alike. Finger length relative to palm size is not constant from person to person. Additionally what constitutes a comfortable fit can vary considerably between individuals. Using one of the methods below will help you to find an approximate glove size, but no method of measurement can substitute for actually trying them on.

Glove Sizing

Place your right hand as shown, with your index finger against the black line. The measurement that follows the right side of your hand is your approximate glove size. **This is a general guide only.**

Using a Tape Measure and the Sizing Guide

Wrap a tape measure around your hand at the widest point (usually the knuckles) and make a loose fist. Note that measurement, round it to the nearest inch and refer to the chart below to find your approximate glove size.

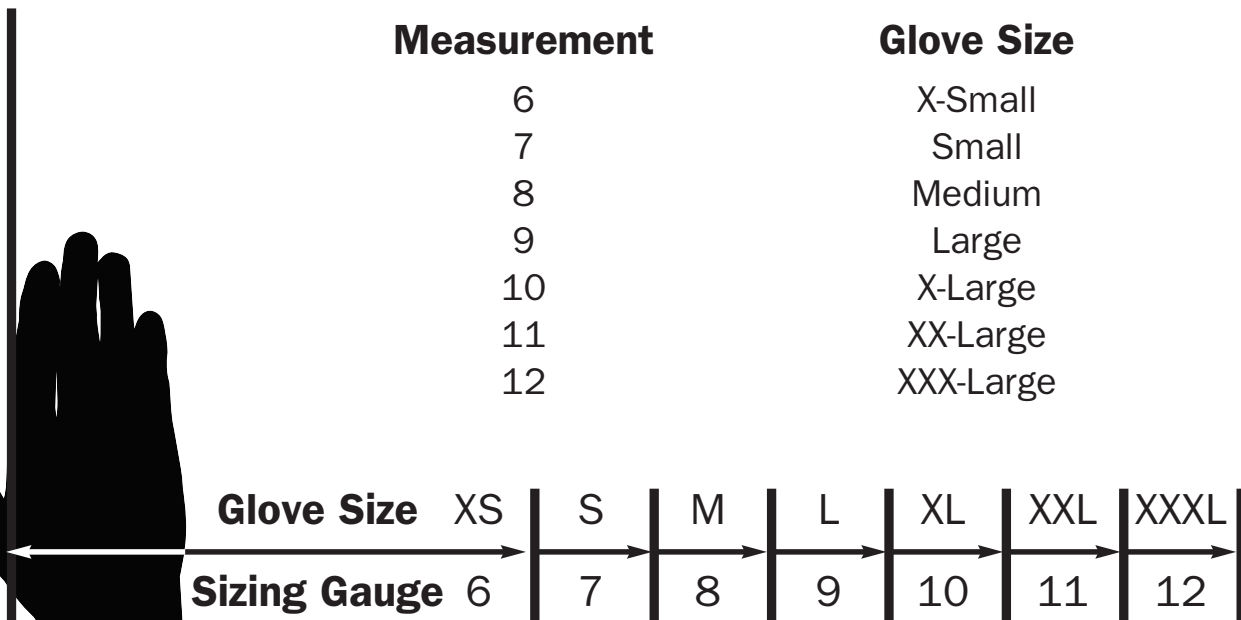

PRODUCTS ARE ONLY AVAILABLE VIA YOUR DISTRIBUTOR

Category 1 - General Handling Gloves

The gloves in this section are ONLY for use when there is no risk to the user. Suitable for use only when the effects on the hands without gloves would be easily reversible or superficial. These products are unmarked and self-certified.



TUFFSAFE Mixed Fibre Gloves

Knitted wrists with a fleece lining. Multi-purpose gloves for lightweight handling.



Size	Weight per 12	Order Code	Price/Pr TB
8	700g	TFF-961-1043K	41.00



Mixed Fibre Gloves

Poly/cotton mix. Knitted wrist. Multi-purpose handling gloves.



Size	Weight per 12	Order Code	Price/Pr TB
9	1.10kg	TFF-961-1050K	26.00
8	1.10kg	TFF-961-1055K	37.00



RUTLAND Rigger Gloves

Rutland Personal Protection Equipment is a comprehensive range of hand, head and eye protection. Manufactured to the highest standards of quality, fully compliant with all current safety standards and packed with inventive features, Rutland branded products are the ones to trust.



NEW



Size	Weight per 12	Order Code	Price/Pr TB
10		RTL-961-4080K	155.00



Stockinette Gloves

Natural Colour

100% cotton. Knitted wrists. Multi-purpose gloves for lightweight handling.



Size	Weight per 12	Order Code	Price/Pr TB
9	3.0kg	TFF-961-1020K	21.00



Stockinette Gloves

Bleached White

100% cotton. Knitted wrists. Multi-purpose gloves for lightweight handling.



Size	Weight per 12	Order Code	Price/Pr TB
7		TFF-961-1010K	21.00
9	2.60kg	TFF-961-1000K	26.00



Cotton Gloves

100% jersey cotton. Knitted wrists and fleece-lined. Multi-purpose gloves for lightweight handling.



Size	Weight per 12	Order Code	Price/Pr TB
9	740g	TFF-961-1045K	31.00



HAND PROTECTION - CAT I - GENERAL HANDLING



Cotton-Backed Leather Gloves

Index Finger Protection

Leather palms, heavy gauge cotton drill backs and knitted wrists. For general and heavy handling.



Size	Weight per 12	Order Code	Price/Pr TB
9	1.35kg	TFF-961	-1140K 102.00

Cotton-Backed Leather Gloves

Leather palms, cotton backs and knitted wrists. For general handling.



Size	Weight per 12	Order Code	Price/Pr TB
10	740g	TFF-961	-1160K 102.00

Terry Towelling Gloves

Thick close loop pile gloves which cushion and protect, also giving good insulation against heat or cold.



Size	Weight per 10	Order Code	Price/Pr TB
10	32oz	TFF-961	-1080K 205.00

Terry Towelling Gauntlets

Thick close terry-towelling loop pile gloves which cushion and protect, also giving good insulation against heat or cold.



Size	Weight per 10	Order Code	Price/Pr TB
10	32oz	TFF-961	-1095K 205.00

SITESAFE Cotton-Backed Leather Gloves

Leather palms, cotton backs and knitted wrists. For general handling.



Size	Order Code	Price/Pr TB
9	SSF-961	-1170K 102.00

Garden & Household Set

Contents:

- 1x pair general-purpose goggles,
- 3x pairs of extra grip cotton drill gloves,
- 5x pairs of disposable latex gloves,
- 1x pair of rubber knee pads.

Model Number	Order Code	Price/1 TB
PPP-2G	TFF-961	-9002B 464.00

PRODUCTS ARE ONLY AVAILABLE VIA YOUR DISTRIBUTOR

TUFFSAFE

Seamless Cotton Gloves

Tuffgrip

General-purpose seamless cotton glove, with a natural latex palm coating to give excellent grip in both wet and dry conditions. For use in warehouses, construction and refuse collection etc. Medium-duty giving good puncture and abrasion resistance.



SEAMLESS



LATEX

Size	Order Code TFF-961	Price/Pr TB
8	-6011B	82.00
9	-6012C	82.00
10	-6013D	82.00



Goat Skin Nappa Gloves

Full grain goat skin gloves provide the highest degree of comfort, flexibility, as well as abrasion resistance. With a cotton stockinette back and velcro fastening to help ensure a good fit the gloves conform to your hands for optimum comfort and dexterity.



Size	Order Code TFF-961	Price/Pr TB
7	-4800A	266.00
8	-4801B	266.00
9	-4802C	266.00
10	-4803D	266.00



Polka-Dot Gloves

Cotton drill backed with polka-dot coated cotton palm, thumb and forefinger. Knitted wrist.



Size	Weight per 12	Order Code TFF-961	Price/Pr TB
9	0.95kg	-1122K	72.00



Cotton Drill Gloves

Standard
100% cotton drill. Knitted wrists. For lightweight and medium handling.

Size: 9.



Colour	Material Weight	Weight per 12	Order Code TFF-961	Price/Pr TB
Navy Blue	6oz	740g	-1121K	57.00
	6oz	740g	-1100K	31.00
Natural	7oz	800g	-1110K	31.00
	8oz	850g	-1120K	57.00



Polka-Dot Gloves

Cotton backed gloves, with palms and fingers covered with vinyl dots to give high grip. Knitted wrists.

Size: 9.



Material Weight	Weight per 12	Order Code TFF-961	Price/Pr TB
6oz	0.80kg	-1250K	40.00
8oz	0.95kg	-1260K	45.00
10oz	1.00kg	-1280K	56.00



Hot Mill Gloves

Canvas fleece double palms, forefinger and thumb, with cotton drill back, knuckles and cuff. Good protection against heat.



Size	Order Code TFF-961	Price/Pr TB
9	-1130K	98.00



Foam Insulated Gloves

Fluorescent PVC coated foam insulated gloves with jersey lining and knitted wrists.



Size	Weight per 10	Order Code TFF-961	Price/Pr TB
10	910g	-1540K	361.00



PERSONAL PROTECTION

HAND PROTECTION - CAT I - GENERAL HANDLING



Chrome Leather Riggers

One-piece chrome leather palms with protection on finger tips and knuckles. Cotton backs. 2" cuffs with arterial protection patches. Elasticated backs.



NYLON LINED PALMS

Size	Weight per 12	Order Code	Price/Pr TB
10	1.60kg	-1300K	101.00



Heavy Duty Riggers

Reinforced with extra palm, index finger and thumb protection. Selected split leather palms, knuckles and finger tips. 2" cuff with arterial protection patches. Elasticated backs.



Split leather



FLEECE LINED PALMS

Size	Weight per 12	Order Code	Price/Pr TB
10	2.00kg	-1320K	181.00



Superior Riggers

S5.

Selected split leather palms, knuckles and finger tips. Fleece-lined palm, cotton drill back. 2" reinforced safety cuffs with arterial protection.

Size: 10.



HARD WEARING - FLEECE LINED

Colour	Weight per 12	Order Code	Price/Pr TB
Red/White	2.70kg	-1360K	150.00
Blue/Gold	3.00kg	-1380K	170.00



Extra Grip Riggers

Maxidot® Standard

Two-piece chrome leather palms with protection on finger tips and knuckles. Cotton backs. 2" safety cuffs with arterial protection patches. Stitched and gathered elasticated backs. Reinforced and dot impregnated thumb and index 'grip zone'. Ideal for handling board and sheet materials.

Size: 9.



For Minimal Risk Only

EXTRA STRONG

FLEECE LINED PALMS

Grade	Weight per 12	Order Code	Price/Pr TB
Standard	2.60kg	-1800K	119.00



Cold Resistant Riggers

Arctic

Selected split leather palms, knuckles and finger tips. Cotton drill backs, 2" reinforced safety cuffs with arterial protection. Thinsulate® lined with a knitted wrist for extra protection against cold.



Standard Chrome Riggers

Chrome leather palms with protection on finger tips and knuckles. Cotton backs. 2" cuffs with arterial protection patches. Elasticated backs.

Size: 10.



Contractor



NYLON LINED PALM

Size	Weight per 12	Order Code	Price/Pr TB
10	1.60kg	-1270K	102.00



THINSULATE® LINED

Size	Weight per 10	Order Code	Price/Pr TB
9	4.20kg	-1900K	464.00



PRODUCTS ARE ONLY AVAILABLE VIA YOUR DISTRIBUTOR

TUFFSAFE

Pigsplit Leather Riggers

High quality pig grain leather. Heavyweight elasticated cotton drill backing. Palm, thumb, forefinger, fingertip and knuckle leather protection. 2" cuff with arterial protection. Double-stitched with fleece lining.

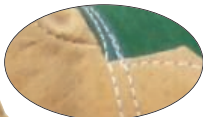

FLEECE LINED PALM

Size	Weight per 12	Order Code	Price/Pr TB
10	1.90kg	TFF-961	170.00



Split Leather Riggers

Leather palms, fleece lined with protection on finger tips and knuckles. 2" cuffs with arterial protection patches.

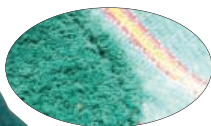

FLEECE LINED PALM

Size	Weight per 12	Order Code	Price/Pr TB
10	1.90kg	TFF-961	150.00



Nappa Palm Riggers

Nappa leather palm, knuckles and finger tips. 2" cuff with arterial protection patches.

Size: 10.

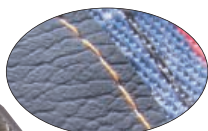

HARD WEARING - FLEECE LINED

Colour	Weight per 12	Order Code	Price/Pr TB
Multi	1.70kg	TFF-961	94.00
Single	1.60kg	-1340K	114.00



Cowhide Riggers

Cowhide leather palms with protection on finger tips and knuckles. Nylon lined palms, cotton backs. 2" cuffs with arterial protection patches. Elasticated backs.



HARD WEARING - FLEECE LINED

Size	Weight per 12	Order Code	Price/Pr TB
10	3.00kg	TFF-961	284.00



Knitted Wrist Riggers

Selected split leather palms with protection on finger tips, knuckles and index finger. Cotton backs and knitted wrists.

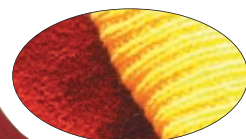

Size	Weight per 12	Order Code	Price/Pr TB
10		TFF-961	155.00
		-1370K	



Open Cuff Chrome Leather Gloves

With 2" open cuffs, easily removed. For general handling. Double palms for heavier use.

Size: 10.



Type	Weight per 12	Order Code	Price/Pr TB
Double	2.10kg	TFF-961	181.00



PERSONAL PROTECTION

HAND PROTECTION - CAT I - GENERAL HANDLING



Cowhide Driver's Gloves

Elasticated back. Lined or unlined. Men's size.



Size	Weight per 12	Order Code TFF-961	Price/Pr TB
10 - Unlined	1.70kg	-1355K	308.00
10 - Lined	1.70kg	-1358K	335.00



Leather Driver's Gloves

Two-piece all-leather glove. Fleece lined. One-piece back. Elasticated cuff with velcro wrist adjustment.



Size	Weight per 12	Order Code TFF-961	Price/Pr TB
10	2.50kg	-1670K	720.00



Lined Gauntlet with Reinforced Thumb

Selected split leather one-piece backs. Fully lined, two-piece - fleece hand and cotton cuff. Reinforced thumb and forefinger webbing.



Size	Order Code TFF-961	Price/Pr TB
10	-1960K	411.00



Vinyl Impregnated Gloves

Abrasion, oil, grease and water resistant. Economical alternative to light duty leather work gloves.

Typical use: metalworking.



Size	Weight per 12	Order Code TFF-961	Price/Pr TB
10	3kg	-1990K	83.00



Lined Gauntlets

Selected split leather one-piece backs. Fully lined, two-piece lining, fleece hand and cotton cuff.

Size: 11.



Colour	Weight per 10	Order Code TFF-961	Price/Pr TB
Green	3.10kg	-1600K	335.00
Red	3.10kg	-1620K	335.00



SITESAFE Fully Lined Gauntlets

Split leather one-piece backs. Fully lined, two-piece lining, fleece hand and cotton cuff.

Size: 11.



Colour	Weight per Pair	Order Code SSF-961	Price/Pr TB
Green	250g	-1610K	308.00
Red	250g	-1620K	308.00



PRODUCTS ARE ONLY AVAILABLE VIA YOUR DISTRIBUTOR

Abrasion Resistant Gloves

Mechanical hazards are associated with handling rough or sharp objects that could damage skin such as brick, concrete, glass, and sheet metal. Mechanical hazards are not associated with moving machinery. Gloves can be a hazard if there is a possibility they could snag in moving parts and put the user in danger.



- a) Abrasion resistance. Scale 1 (low) to 4 (high).
 - b) Cut resistance. Scale 1 (low) to 5 (high).
 - c) Tear resistance. Scale 1 (low) to 4 (high).
 - d) Puncture resistance. Scale 1 (low) to 4 (high).
- 0 = Fail. X = No test carried out.

Each **Abrasion Resistant** glove in this section has a rating - the higher the number, the greater the protection.



TUFFSAFE Black Nylon Lined PU Coated Gloves

These gloves are designated as intermediate design. The user must select the appropriate gloves for the task in hand and should consult their supplier for advice. CE approved to **BS EN388 Cat II**.



Size	Order Code TFF-961	Price/Pr TB
6	-6330L	50.00
7	-6331M	50.00
8	-6332N	50.00
9	-6333P	50.00
10	-6334Q	50.00



Fully PVC-Coated Gloves

Tough flexible PVC-coated gloves with knitted wrists. Provide excellent dry grip for general applications.



Nitrile-Coated Gloves

With cotton interlock liner. Combines the comfort of cotton with the protection of nitrile. Textured surface, durable and washable. Ideal for assembly, fabrication and handling.

Open Backed Knitted Wrist
Open backed to keep hands cooler in warm conditions.



Size	Colour	Order Code TFF-961	Price/Pr TB
8		-3540K	78.00
9	Yellow	-3560K	78.00
10		-3580K	78.00

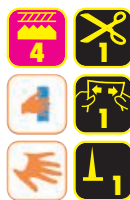

Size	Weight per 12	Order Code TFF-961	Price/Pr TB
8	1.2kg	-1390K	94.00
9	1.2kg	-1400K	94.00
10	1.2kg	-1460K	94.00



Seamless Gloves

White polyurethane coating on a 13 gauge seamless knitted white nylon liner with knitted elasticated cuffs. Polyurethane coating to palms and fingertips, provides dexterity and strong abrasion resistance for the handling of fine and dirty objects.

CE approved to **BS EN388 Cat II**.



Knitted Wrist
Fully coated for all-round protection.



Size	Weight per 12	Order Code TFF-961	Price/Pr TB
8	1.10kg	-3740K	78.00
9	1.20kg	-3760K	78.00
10	1.25kg	-3780K	78.00



Size	Colour	Order Code TFF-961	Price/Pr TB	Size	Colour	Order Code TFF-961	Price/Pr TB
6		-6310A	83.00	6		-6320A	83.00
7	White	-6311B	83.00	7	Grey	-6321B	83.00
8		-6312C	83.00	8		-6322C	83.00
9		-6313D	83.00	9		-6323D	83.00
10	White	-6314E	83.00	10	Grey	-6324E	83.00
				11		-6325F	83.00



PERSONAL PROTECTION

HAND PROTECTION - CAT II - ABRASION RESISTANT



Nitrile-Coated Gloves

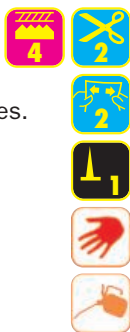

For excellent resistance to abrasion, cuts and snags, punctures, grease and oil. Tough general-purpose gloves. 'Nitron' general-purpose. CE Intermediate design.

Fully Coated Knitted Wrist
For all round protection.



Size	Order Code	Price/Pr TB
9	-2760K	99.00
10	-2780K	99.00



Nitrile Gloves



Nylon comfortable flexible liner with a Nitrile palm coating. Designed for handling oily components that do not offer a cut risk. Conforms to EN388 4132.

NEW



Size	Order Code	Price/Pr TB
6	-6300A	40.00
7	-6301B	40.00
8	-6302C	40.00
9	-6303D	40.00
10	-6304E	40.00



Open Back Knitted Wrist
To keep hands cooler in warm conditions.



Size	Order Code	Price/Pr TB
10	-2770K	99.00



PU Coated Gloves

PU Glove
Nylon seamless liner with a palm PU coating. Great for handling dry objects. Excellent dexterity. Conforms to EN388 4131.

NEW



Size	Order Code	Price/Pr TB
6	-6330L	35.00
7	-6331M	35.00
8	-6332N	35.00
9	-6333P	35.00
10	-6334Q	35.00



Fully Coated Safety Cuff
With extra wrist protection.



Size	Order Code	Price/Pr TB
10	-2800K	99.00



Latex Coated Gloves

Nylon liner with latex palm coating. Ideal for handling rough items in dry or damp conditions. Conforms to EN388 2243.

NEW



Size	Order Code	Price/Pr TB
7	-5990A	45.00
8	-5991B	45.00
9	-5992C	45.00
10	-5993D	45.00



PERSONAL PROTECTION

PRODUCTS ARE ONLY AVAILABLE VIA YOUR DISTRIBUTOR

Tear Resistant Gloves & Sleeves

Mechanical hazards are associated with handling rough or sharp objects that could damage skin such as brick, concrete, glass, and sheet metal. Mechanical hazards are not associated with moving machinery. Gloves can be a hazard if there is a possibility they could snag in moving parts and put the user in danger.

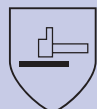

- a) Abrasion resistance. Scale 1 (low) to 4 (high).
 - b) Cut resistance. Scale 1 (low) to 5 (high).
 - c) **Tear resistance.** Scale 1 (low) to 4 (high).
 - d) Puncture resistance. Scale 1 (low) to 4 (high).
- 0 = Fail. X = No test carried out.

Each **Tear Resistant** glove in this section has a rating - the higher the number, the greater the protection.



a. b. c. d.

TUFFSAFE Knitted Cotton Gloves

Super-Grip™ Criss-Cross

Heavyweight knitted cotton gloves with high grip PVC lattice and elasticated wrists.



Size	Weight per 12	Order Code	Price/Pr TB
10	1.20kg	TFF-961 -1240K	82.00



Seamless Knitted Gloves

Tufflite™

Grey nitrile foam coating on a 13 gauge seamless knitted white nylon liner with knitted elasticated cuffs. Nitrile coating to palms and fingertips, provides excellent dexterity with precise grip.



Size	Order Code	Price/Pr TB
6	-6300A	77.00
7	-6301B	77.00
8	-6302C	77.00
9	-6303D	77.00
10	-6304E	77.00



Cut Level 3 Resistant Sleeve

Orange

Blended fibres produce a cut resistant comfortable good fitting sleeve. 18 inches long. Conforms to EN 388 434X.

EN 407 X.1.X.X.X.X.



Length	Order Code	Price/Pr TB
455mm (18")	TFF-961 -2550E	399.00

NEW

All Priced Per Sleeve



Latex-Coated Gloves

Tuffgrip II™

The Tuffsafe® coated latex gloves have a premium quality green natural rubber coating applied to a seamless polycotton liner to produce a glove with excellent wet and dry grip, whilst at the same time offering outstanding protection from mechanical hazards. Raised latex crinkle finish coating to palms and fingertips, breathable open back and continuous knitted wrist for improved comfort over extended periods of wear. Conforms to EN388.



LATEX



Size	Order Code	Price/Pr TB
8	-5991B	88.00
9	-5992C	88.00
10	-5993D	88.00



PERSONAL PROTECTION

Cut Level 5 Resistant Sleeve

Polyamide blend of fibres producing protection with comfort. 460mm (18") long. Conforms to EN388 454X.

EN 407 X.1.X.X.X.X.



Length	Order Code	Price/Pr TB
460mm (18")	TFF-961 -2551F	450.00

NEW

All Priced Per Sleeve



HAND PROTECTION - CAT II - PUNCTURE RESISTANT WELDER'S

Puncture Resistant Gloves

Many types of operator are exposed to sharp object injuries that can be caused by wooden or metal splinters and protruding nails and fixings in timbers, packing cases etc, that are often not clearly visible.

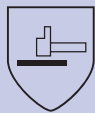

- a) Abrasion resistance. Scale 1 (low) to 4 (high).
 - b) Cut resistance. Scale 1 (low) to 5 (high).
 - c) Tear resistance. Scale 1 (low) to 4 (high).
 - d) Puncture resistance. Scale 1 (low) to 4 (high).
- 0 = Fail. X = No test carried out.

a. b. c. d.

Each **Puncture Resistant** glove in this section has a rating - the higher the number, the greater the protection.



TUFFSAFE Natural Rubber Seamless Gloves - Kevlar Lined

Tuffgrip KL™

Premium blue natural rubber coating on a seamless **100% Kevlar® liner**, provides excellent wet/dry grip, cut resistance and protection from mechanical hazards. Raised latex crinkle finish to palms and fingertips, breathable open back and continuous knitted wrist.



Size	Order Code TFF-961	Price/Pr TB
8	-6111B	514.00
9	-6112C	514.00
10	-6113D	514.00



KENNEDY Reversible Welder's Gauntlet

Reversible (ambidextrous) lined, green gauntlet. Type A. CE approved to EN12477, EN388, EN407.



Size	Weight per pair	Order Code KEN-961	Price/Pr TB
10.5	250g	-1940K	387.00



EN12477 - Welding Gloves

EN12477:2003 defines relevant requirements and test methods for protective gloves for use in manual metal welding and allied processes. Under this standard, all gloves to be used for welding must be independently tested and certified by an official notified body, and must meet certain performance levels.

Type B gloves are recommended where high dexterity is required, e.g. TIG welding. **Type A** gloves are recommended for all other welding processes. The type and all appropriate markings (Pictograms) will be marked on the product, its packaging and the user instructions.

EN12477:2003 Minimum Performance Levels for Welding Gloves

	TYPE A	TYPE B
MECHANICAL RISKS (as per EN388:2003)		
Abrasion Resistance	Level 2	Level 1
Blade Cut Resistance	Level 1	Level 1
Tear Resistance	Level 2	Level 1
Puncture Resistance	Level 2	Level 1
THERMAL HAZARDS (as per EN407:2004)		
Burning Behaviour Resistance	Level 3	Level 2
Contact Heat Resistance	Level 1	Level 1
Convective Heat Resistance	Level 2	Level X

Radiant Heat Resistance	Level X	Level X
Small Molten Metal		
Splash Resistance	Level 3	Level 2
Large Molten Metal Splash		
Resistance	Level X	Level X

GENERAL REQUIREMENTS (as per EN420:2003)
 Glove Dexterity Level 1 Level 4
ELECTROSTATIC PROPERTIES - Optional (as per EN1149-2:1997)
 Dry Conditions Test (for Arc Welding) ... 10⁶ ohms 10⁵ ohms

Grey Leather Tig Welder's Gloves

Constructed from soft high quality nappa leather for the palm, and stiff 150mm chrome leather cuff. The soft leather palm and fingers offer a superb feel and good durability for precision welding. Good comfort and flexible with a good level of dexterity.

360mm overall length.

EN420 (Dexterity)

Level 5



Size	Order Code TFF-961	Price/Pr TB
10	-1650K	318.00



TUFFSAFE Heavy Duty Welder's Gauntlet

Full five finger welder's gauntlet manufactured from select split leather with a full cotton lining with a one piece back. Reinforced palm and thumb for increased wear with no exposed seams to burn. Kevlar® sewn throughout. Tested to EN388: 2003 & EN407: 2004.



Size	Weight per Pair	Order Code TFF-961	Price/Pr TB
10	341g	-1580K	514.00



PRODUCTS ARE ONLY AVAILABLE VIA YOUR DISTRIBUTOR



Chemical Resistant PVC-Coated Gauntlets

Tough flexible PVC coated gloves with open cuffs and jersey lining.



Size	Weight per 12	Order Code TFF-961	Price/Pr TB
280mm	2.20kg	-1480K	137.00
355mm	2.30kg	-1500K	150.00

Chemical Resistant PVC-Coated Gloves

Tough flexible PVC coated gloves with a textured finish for extra grip. Open cuffs with jersey lining.

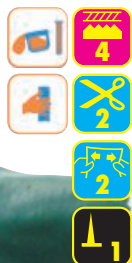

Size	Weight per 12	Order Code TFF-961	Price/Pr TB
9	2.20kg	-1550K	134.00

Vinyl Disposable Gloves

Sensitive, strong and comfortable. USDA accepted. For food, hospital, laboratory use and countless applications. Intermediate Design. For minimal risk only.



VINYL

PACK OF 100

NEW



Size	Weight per box	Order Code Blue	TFF-961 Clear	Price/Pk TB
6½	0.80kg	-7030A	-7040A	335.00
7½	0.89kg	-7031B	-7041B	335.00
8½	1.25kg	-7032C	-7042C	335.00
9½	1.35kg	-7033D	-7043D	335.00

Latex Disposable Gloves

Micro textured natural rubber latex disposable gloves. Finger hugging latex provides maximum dexterity, sensitivity and comfort. Made from 100% natural rubber latex textured for extra grip. Ambidextrous with rolled cuff for added strength when fitting or removing.



LATEX

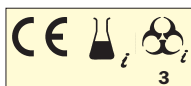

PACK OF 100



Size	Type	Order Code TFF-961	Price/Pk TB	Size	Type	Order Code TFF-961	Price/Pk TB
7		-3120A	493.00	7		-3110A	514.00
8		-3121B	493.00	8	Powder	-3111B	514.00
9	Powdered	-3122C	493.00	9	Free	-3112C	514.00
10		-3123D	493.00	10		-3113D	514.00

Nitrile Disposable Gloves

High quality nitrile seamless gloves which are ambidextrous to fit either hand. Non-sterile.



Non powdered: For use in electronics, pharmaceutical, laboratory, medical, dental and food processing applications.



NITRILE

NEW



PACK OF 100



Size	Type	Order Code TFF-961	Price/Pk TB
6½		-4050A	567.00
8½	Powder	-4051B	567.00
8½	Free	-4052C	567.00
9½		-4053D	567.00

SITESAFE Nitrile Disposable Gloves

Seamless nitrile gloves for single use only. This latex-free, low protein product can help reduce the risk of cross contamination in the work environment. This product is for general use in minimal risk conditions. Non-sterile.



NITRILE

NEW



PACK OF 100



Size	Type	Order Code SSF-961	Price/Pk TB	Size	Type	Order Code SSF-961	Price/Pk TB
S		-4040A	387.00	S		-4030A	411.00
M		-4041B	387.00	M	Powder	-4031B	411.00
L	Powdered	-4042C	387.00	L	Free	-4032C	411.00
XL		-4043D	387.00	XL		-4033D	411.00

PERSONAL PROTECTION

TUFFSAFE *Back Support Belt*

Provides comfortable support from lower back strain. Helps to reduce lower back discomfort. 8" wide elasticated double back support belt.



Front **Back**

Waist Size	Order Code	Price/Pr TB
Small 28-32"	-2010A	603.00
Medium 32-38"	-2011B	603.00
Large 38-47"	-2012C	603.00
X-Large 46-56"	-2013D	603.00

1 1/4" wide adjustable shoulder straps.



KENNEDY *High Density Foam Knee Pads*

High Density Foam Knee Pads

Quick release velcro fastening. One size fits all. Flexible straps prevent binding behind the knee. Non-marring face protects surfaces. Non-skid material helps avoid slipping. Lightweight design for comfort when standing.



Size (mm)	Weight each	Order Code	Price/Pr TB
145 x 250	250g	-4980K	680.00

Partial Hard Case Knee Pads

Quick release velcro fastening. One size fits all. Flexible straps prevent binding behind the knee. Non-marring face protects surfaces. Foam cushion beneath cap absorbs impact.



Size (mm)	Weight each	Order Code	Price/Pr TB
180 x 250	200g	-4990K	799.00

KENNEDY *One Strap Knee Pads*

Chrome leather with one strap.



Size (mm)	Weight each	Order Code	Price/Pr TB
1200 Dia.	220g	-4960K	1140.00

Heavy Duty Knee Pads

Heavy duty chrome leather with two straps.



Size (mm)	Weight each	Order Code	Price/Pr TB
195 x 215	430g	-4920K	1216.00

Moulded Rubber Knee Pads

Heavy duty. One piece construction. Manufactured from black polyurethane foam. Deep ribbed contact zone to reduce the risk of slipping. Five point adjustable elasticated strap. Conforms to, and is stamped **CE**. Suitable for regular use, industrial and professional applications.



Size (mm)	Order Code	Price/Pr TB
135 x 155	-4930K	1029.00

Black Leather Knee Pads

Heavy duty. A robust construction with buckle straps and a felt padding lining for added comfort.



Size (mm)	Order Code	Price/Pr TB
160 x 130	-4940K	2436.00

Neoprene Gel Knee Pads

Quick release velcro fastening. One size fits all. Flexible straps prevent binding behind the knee.



Size (mm)	Order Code	Price/Pr TB
190 x 230	-5010K	1296.00

Neoprene Gel Elbow Pads

Quick release velcro fastening. One size fits all. Flexible straps for added comfort. Gel filled pad absorbs impact.



Size (mm)	Order Code	Price/Pr TB
150 x 190	-5020K	720.00

Full Hard Case Knee Pads

Quick release velcro fastening. One size fits all. Flexible straps prevent binding behind the knee. Non-marring face protects surfaces. Foam cushion beneath cap absorbs impact.



Size (mm)	Order Code	Price/Pr TB
185 x 235	-5000K	924.00

TUFFSAFE *Knee Pad Inserts*

Work trouser insert knee pads manufactured from 100% lightweight flexible moulded polythene. Does not hinder the wearer when walking. Supplied in pairs. Manufactured to: **EN14404:2004+A1:2010**.



NEW

Size (mm)	Order Code	Price/Pr TB
215 x 165	-8820A	175.00

Fall Arrest Equipment

Health and safety legislation states that fall protection measures must be put in place for any person working at a height of two metres or more where a fall hazard exists.

If it is not feasible to eliminate the hazard using a collective system, then a personal protective equipment system must be selected and used, be it a restraint, work positioning or fall arrest product.

This system consists of a full body harness, an intermediate attachment and an anchorage connector.

The systems can only be used if a suitable anchorage point is located close to the area.



Rope or Webbing Lanyards

The choice is primarily one of preference as they both offer the same high level of performance.

Rope Lanyards - Can become rigid and difficult to handle when dirty - but offer great durability and a longer working life than webbing.

Webbing Lanyards - Are more lightweight, visible and easier to handle than rope - but offer less durability.



Arrest Product Selection

Lanyards - Maximum length two metres. For work requiring limited movement.

Fall Arrest Blocks - 2.5 - 40m. Automatic retractable cable allows freedom of movement. For workers who need to move relatively quickly up and down on a worksite. The automatic braking system arrests a fall in seconds.

Rope Grabs - For freedom to move around an elevated worksite (this could be horizontal or vertical, fixed or flexible). In the event of a fall, the guided type fall arrester grabs onto the anchorage line and arrests the fall - resulting in limited travel.

Work at Height Regulations 2005

The **Work at Height Regulations 2005** came into force on 6 April 2005. The Regulations apply to all work at height where there is a risk of a fall liable to cause personal injury.

They place duties on employers, the self-employed, and any person that controls the work of others (for example facilities managers or building owners who may contract others to work at height).

The **Work at Height (Amendment) Regulations 2007** which came into force on 6 April 2007 apply to those who work at height providing instruction or leadership to one or more people engaged in caving or climbing by way of sport, recreation, team building or similar activities in Great Britain.

As part of the Regulations, duty holders must ensure:

- all work at height is properly planned and organised;
- those involved in work at height are competent;
- the risks from work at height are

assessed and appropriate work equipment is selected and used;

- the risks from fragile surfaces are properly inspected and maintained.

There is a simple hierarchy for managing and selecting equipment for work at height. Duty holders must:

- avoid work at height where they can;
- use work equipment or other measures to prevent falls where they cannot avoid working at height; and
- where they cannot eliminate the risk of a fall, use work equipment or other measures to minimise the distance and consequences of a fall should one occur.

The Regulations include schedules giving requirements for existing places of work and means of access for work at height, collective fall prevention (eg guardrails and working platforms), collective fall arrest (eg nets, airbags, etc), personal fall protection (eg work restraints, fall arrest and rope access) and ladders.

TUFFSAFE Lanyard Block

Retractable Energy Absorbing Lanyard Block

Retractable mini web block ideal for personal issue to operatives working at height. The unit is designed to be connected and worn directly on a fall arrest harness. Locks on with decelerating brake action in the event of a fall and recoils the lanyard when slack is introduced to reduce trip hazards in tight work spaces. Compact design, built in shock pack. Has a working length of 2.5m.

Certified to: **CE 0320, EN364, EN360.**

Max fall arrest force: 6KN.

Size (L x W x D):
100 x 110 x 75mm.



Model Number	Weight each	Order Code	Price/1 TB
TSEAL1	1.12kg	-3905E	5149.00

Parking Loops

Parking loops are simple and easy to use. Prevents wear on harness straps. The clip is designed to fit onto the shoulder strap of the harness. Once fitted the karabiner is connected directly to the loop for safe storage when not in use. This stops the lanyard from trailing on the floor and causing a trip hazard.



Model Number	Weight each	Order Code	Price/1 TB
TSPL	10g	-3935E	208.00

Trauma Suspension Straps

Trauma suspension straps are simple and easy to use and can fit all Tuffsafe harnesses. They allow the worker to stand up in their harness to ease the discomfort whilst suspended from a lanyard after a fall. Helps release the tension within the harness straps to relieve pressure on the groin which helps prevent loss of circulation to the legs and feet. Prior to use attach one pack to the outer side of each leg strap. In the event of a fall unzip the pouches to release the straps and thread the plain end through both chrome rings and back through only one and pull tight to form a loop approx shin height. Stand up slowly on the straps and the discomfort will be relieved. Lightweight and unobstructive.



Model Number	Weight each	Order Code	Price/1 TB
TSTSS	150g	-3977F	2059.00

SITESAFE® Body Harness - 1 Point

One point full body harness made of strong 45mm wide polyester webbing. Lightweight and durable therefore ideal for all day comfort and dependability. Adjustable thigh and chest straps with metal buckles and back anchorage dorsal D-ring attachment. Capable of supporting up to 310lb (22st/140.6kg).



CE 0321 EN 361:2002

Model Number	Order Code SSF-962	Price/1 TB
BHP010	-8010K	2070.00

Body Harness 2 Point

Two point full body harness made of strong 45mm wide polyester webbing. Lightweight and durable therefore ideal for all day comfort and dependability. Adjustable thigh and chest straps with metal buckles and back anchorage dorsal D-ring attachment. Two point anchor straps for extra harnessing support. Capable of supporting up to 310lb (22st/140.6kg).



CE 0321 EN 361:2002

Model Number	Order Code SSF-962	Price/1 TB
BHP020	-8020K	2653.00

Body Harness 2 Point - With Belt

Two point full body harness made of strong 45mm wide polyester webbing. Adjustable thigh and chest straps with metal buckles and back anchorage dorsal D-ring attachment. Two point anchor straps for extra harnessing support. Detachable belt harness including adjustable strap with metal buckles and two D-rings. Two polyester/plastic 90mm D-rings and clip attachment at the rear. Capable of supporting up to 310lb (22st/140.6kg).



CE 0321 EN 361:2002 EN361:2002

Model Number	Order Code SSF-962	Price/1 TB
BHP025	-8025K	4377.00

The TuffSafe range of fall arrest harnesses are lightweight, durable and manufactured from 45mm water repellent polyester webbing with rip stitch fall indicators. Ideal for all day comfort and dependability. Fully adjustable for easy fitting. All fittings are made from high tensile steel alloy.

All TuffSafe harnesses are certified to: CE 0320, EN361, EN358, EN364.

Rear 'D' Harness

TSH1
One point attachment:
One dorsal D-ring.
Weight: 0.95kg.



Model Number	Harness Points	Order Code TFF-962	Price/1 TB
TSH1	1	-3911A	2653.00

Front & Rear 'D' Harness

TSH2
Two point attachment:
One dorsal D-ring.
One chest mounted D-ring.
Weight: 1.15kg.



Model Number	Harness Points	Order Code TFF-962	Price/1 TB
TSH2	2	-3912B	3089.00

Front & Rear 'D' Harness

TSH3
Three point attachment:
One Dorsal D-ring.
Two side D-rings.
Weight: 1.25kg.



Model Number	Harness Points	Order Code TFF-962	Price/1 TB
TSH3	3	-3913C	6179.00

Front & Rear 'D' Harness

TSH4
Four point attachment:
One dorsal D-ring.
One chest mounted D-ring.
Two side D-rings.
Weight: 1.75kg.



Model Number	Harness Points	Order Code TFF-962	Price/1 TB
TSH4	4	-3914D	6896.00

Shock Absorbers

Lightweight, durable and fitted with a shock absorber pack and a 70mm delta link. Certified to: CE 0320, EN 364, EN 355.

Max fall arrest force: 6KN.

TSSA1 & TSSA11

'Soft Edge' 32mm wide, cut resistant polyester webbing provides greater strength and resistance along with its water repellent coating can help prolong its life.



Model Number	Weight each	Order Code TFF-962	Price/1 TB
TSSA1	0.60kg	-3951B	2600.00
TSSA11	0.90kg	-3961L	3661.00

TSSA9

Twin legs allow movement between anchorage points. The elasticated lanyard reduces the amount of hanging slack. Lightweight, durable and fitted with a shock absorber pack and a 70mm delta link. The 35mm tubular webbing and tear webbing provides greater strength and resistance.



Model Number	Weight each	Order Code TFF-962	Price/1 TB
TSSA9	1.50kg	-3959J	6179.00

SITESAFE®

Disposable Visitor Coat

This single use SiteSafe® visitors coat is manufactured from low density polyethylene (LDPE) material and has front press stud fastening. One size only.



PACK OF 25

Colour	Pack Quantity	Order Code SSF-962	Price/Pk TB
White	25	-9000K	617.00

Non-Woven Visitor Coats

This visitor's coat from Sitesafe® is manufactured from a 35gm² non-woven material, it has a collar and a stud fastening front.



PACK OF 25

Size	Pack Quantity	Order Code SSF-962	Price/Pk TB
M	25	-9002C	1366.00
L	25	-9002D	1366.00
XL	25	-9002E	1366.00

Polyethylene Oversleeves

Protective sleeve and arm covering, elasticated at both ends for a comfortable fit manufactured from polyethylene. Available in a range of colours.

One size: 40 x 20cm (16" x 8").

PACK OF 100



Colour	Pack Quantity	Order Code SSF-962	Price/Pk TB
Blue	100	-5810B	222.00
Green	100	-5810G	222.00
Red	100	-5810R	222.00
White	100	-5810W	222.00
Yellow	100	-5810Y	222.00

Disposable Overshoes

SiteSafe® overshoes provide cost effective solution to many of the problems associated with cross contamination that can be caused by dirty footwear. In many areas where a clean environment is important or required by regulation, staff and visitors are able to enter and move freely using their own footwear covered by a SiteSafe® overshoe. Manufactured from polyethylene with an elasticated closure.

PACK OF 100



Colour	Pack Quantity	Order Code SSF-962	Price/Pk TB
Blue	100	-5800B	222.00
Green	100	-5800G	222.00
Red	100	-5800R	222.00
White	100	-5800W	222.00
Yellow	100	-5800Y	222.00

Disposable Polythene Aprons

SiteSafe® disposable single use aprons manufactured from low density polythene. One size only 690 x 1070mm.



PACK OF 100

Colour	Pack Quantity	Order Code SSF-962	Price/Pk TB
Blue	100	-1150B	514.00
Green	100	-1150G	514.00
Red	100	-1150R	514.00
White	100	-1150W	514.00
Yellow	100	-1150Y	514.00

Disposable Hair Nets

Disposable bonded polypropylene hair nets have a fine open weave with stitched elasticated opening. One size fits all.



PACK OF 100

Colour	Pack Quantity	Order Code SSF-962	Price/Pk TB
Blue	100	-2900B	691.00
White	100	-2900W	691.00

Bouffant Caps

The Sitesafe® disposable bouffant will completely cover your hair. Made from soft and lightweight polypropylene with a stitched elasticated edge. One size fits all.



PACK OF 100

Colour	Pack Quantity	Order Code SSF-962	Price/Pk TB
Blue	100	-1260B	239.00
White	100	-1260W	239.00

Mob Caps

SiteSafe® Mob caps completely cover a person's hair. Manufactured from soft and comfortable, thermally bonded light polypropylene fibre with an encapsulated double stitched elasticated edge. One size fits all.



PACK OF 100

Colour	Pack Quantity	Order Code SSF-962	Price/Pk TB
Blue	100	-5500B	273.00
Green	100	-5500G	273.00
Red	100	-5500R	273.00
White	100	-5500W	273.00
Yellow	100	-5500Y	273.00

Beard Masks

SiteSafe® with single elasticated fastening, beard mask is manufactured from polypropylene. One size only.



PACK OF 100

Colour	Pack Quantity	Order Code SSF-962	Price/Pk TB
Blue	100	-1200B	160.00
White	100	-1200W	160.00

PERSONAL PROTECTION



Cotton Drill Boiler Suits

Comfortable fit suitable for garage, workshop, service, maintenance, general DIY and many other applications. Hard wearing. Concealed press studs. Chest pockets, side pockets, back pocket and lower leg pocket. Elasticated waist. Machine washable. Made from 100% cotton.

Colour: navy.



Colour	Size	Order Code TFF-962	Price/1 TB
Navy Blue	S 36/38"	-2510A	1647.00
	M 40/41"	-2511B	1647.00
	L 42/44"	-2512C	1647.00
	XL 46/48"	-2513D	1647.00
	2XL 50"	-2514E	1647.00

Polycotton Boiler Suits

Comfortable fit suitable for garage, workshop, service, maintenance, general DIY and many other applications. Hard wearing. Concealed press studs. Chest pockets, side pockets, back pocket and lower leg pocket. Elasticated waist. Easy care and higher wash rate due to the shrink resistant and colour fade resistant polycotton fabric. Machine washable. Made from 80% polyester, 20% cotton.

Colour: royal blue.



Colour	Size	Order Code TFF-962	Price/1 TB
Royal Blue	S 36/38"	-5810A	1092.00
	M 40/41"	-5811B	1092.00
	L 42/44"	-5812C	1092.00
	XL 46/48"	-5813D	1092.00
	2XL 50"	-5814E	1092.00

Waterproof Suits

Waterproof hooded jacket with drawstring closure, storm front with plastic zipper, raglan sleeves with wind cut off, patch pockets with flap in the front and vented cape back and underarm vents for improved user comfort. The trousers have elasticated waist band, no fly front and press stud ankle adjustment.



Colour	Size	Weight each	Order Code TFF-962	Price/1 TB
Green	S	1.00kg	-5010A	670.00
	M	1.05kg	-5011B	670.00
	L	1.10kg	-5012C	670.00
	XL	1.20kg	-5013D	670.00
Orange	S	1.00kg	-5020A	670.00
	M	1.05kg	-5021B	670.00
	L	1.10kg	-5022C	670.00
Yellow	XL	1.20kg	-5023D	670.00
	S	1.00kg	-5030A	670.00
	M	1.05kg	-5031B	670.00
Yellow	L	1.10kg	-5032C	670.00
	XL	1.20kg	-5033D	670.00



Caps - Breathable

Six-panel caps with cloth headbands. One size fits all. Waterproof plastic peak insert. With four breathable mesh rear panels.



NEW

Colour	Order Code KEN-957	Price/1 TB
White	-4480K	99.00

Caps - Full Panel

Six-panel caps with cloth headbands. One size fits all. Waterproof plastic peak insert.



NEW

Colour	Order Code KEN-957	Price/1 TB
White	-4380K	80.00

Caps - Cotton Fleece

Six-panel caps with ventilation holes. One size fits all. Waterproof plastic peak insert.



NEW

Colour	Order Code KEN-957	Price/1 TB
Red	-4540K	70.00

PERSONAL PROTECTION

SITESAFE Polo Shirts

180gsm, 50% polyester, 50% cotton fabric, with three button placket. Combining quality and durability.
Colours: black and navy.



Black



Navy

NEW

Size	Order Code SSF-962		Price/1 TB
	Black	Navy	
S	-6000C	-6004C	425.00
M	-6000D	-6004D	425.00
L	-6000E	-6004E	425.00
X	-6000F	-6004F	425.00
2XL	-6000G	-6004G	425.00

Sweat Shirts

280gsm, 50% polyester, 50% cotton fabric with drop shoulder design. Knitted collar, cuffs and waistband. Combining quality and durability.
Colours: black and navy.



Black



Navy

NEW

Size	Order Code SSF-962		Price/1 TB
	Black	Navy	
S	-6160C	-6164C	675.00
M	-6160D	-6164D	675.00
L	-6160E	-6164E	675.00
X	-6160F	-6164F	675.00
2XL	-6160G	-6164G	675.00

Fleeces

300gsm, anti-pill fleece. Interactive full zip. Comfort cuffs. Two hip pockets with zip closures. Combining quality and durability.
Colours: black and navy.



Black



Navy

NEW

Size	Order Code SSF-962		Price/1 TB
	Black	Navy	
S	-3760C	-3764C	999.00
M	-3760D	-3764D	999.00
L	-3760E	-3764E	999.00
X	-3760F	-3764F	999.00
2XL	-3760G	-3764G	999.00

PERSONAL PROTECTION

TUFFSAFE T-Shirts

200gsm, 65% polyester, 35% cotton fabric.



Navy

NEW



Royal



Black

Size	Order Code TFF-962			Price/1 TB
	Black	Navy	Royal	
S	-7100B	-7101B	-7102B	435.00
M	-7100C	-7101C	-7102C	435.00
L	-7100D	-7101D	-7102D	435.00
XL	-7100E	-7101E	-7102E	435.00
2XL	-7100F	-7101F	-7102F	435.00

Sweatshirts

350gsm, 65/35 polycotton with triple stitched seams. Elasticated cuff, neckline and waistband. Brushed fleece liner. Half-moon yoke. Taped neckline. Set in sleeves.



Black

NEW



Navy



Royal

Size	Order Code TFF-962			Price/1 TB
	Black	Navy	Royal	
S	-6060B	-6061B	-6062B	825.00
M	-6060C	-6061C	-6062C	825.00
L	-6060D	-6061D	-6062D	825.00
XL	-6060E	-6061E	-6062E	825.00
2XL	-6060F	-6061F	-6062F	825.00

Polo Shirts

220gsm, 50/50 polycotton fabric with triple stitched seams. Half-moon yoke, padded neck line, tipped collar and cuffs. Hemmed sleeve ends.



Navy

NEW



Royal



Black

Size	Order Code TFF-962			Price/1 TB
	Black	Navy	Royal	
S	-5300B	-5301B	-5302B	465.00
M	-5300C	-5301C	-5302C	465.00
L	-5300D	-5301D	-5302D	465.00
XL	-5300E	-5301E	-5302E	465.00
2XL	-5300F	-5301F	-5302F	465.00

Micro Fleece

400gsm, micro fleece with full length YKK zip. Soft cuff design. Internal pockets. External large YKK zipped pockets.



Navy

NEW



Black



Royal

Size	Order Code TFF-962			Price/1 TB
	Black	Navy	Royal	
S	-3230B	-3231B	-3232B	1299.00
M	-3230C	-3231C	-3232C	1299.00
L	-3230D	-3231D	-3232D	1299.00
XL	-3230E	-3231E	-3232E	1299.00
2XL	-3230F	-3231F	-3232F	1299.00

PERSONAL PROTECTION

PRODUCTS ARE ONLY AVAILABLE VIA YOUR DISTRIBUTOR

SITESAFE

Men's Soft Shell Jackets

260gsm, two layer construction soft shell with contrast trim.
Full length zip fastening.
Two zipped side pockets.

Colours:



NEW



Size	Order Code SSF-962		Price/1 TB
	Black	Navy	
S	-6140C	-6144C	2250.00
M	-6140D	-6144D	2250.00
L	-6140E	-6144E	2250.00
XL	-6140F	-6144F	2250.00
2XL	-6140G	-6144G	2250.00

Men's Soft Shell Gilets

SS29V4
260gsm, two layer soft shell construction.
Full length fastening zip. Contrast trim.
Two hip pockets and one chest pocket.



NEW

Colours:



Size	Order Code SSF-962		Price/1 TB
	Black	Navy	
S	-6110C	-6114C	1999.00
M	-6110D	-6114D	1999.00
L	-6110E	-6114E	1999.00
XL	-6110F	-6114F	1999.00
2XL	-6110G	-6114G	1999.00

TUFFSAFE

Men's Executive Soft Shell Jackets

290gsm, three layer construction with 10,000/3,000 breathable waterproof membrane.
Contrast trim sleeves. Two side zipped pockets. One chest zipped pocket. One zipped arm pocket.

Colours:

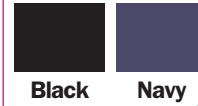

NEW



Size	Order Code TFF-962		Price/1 TB
	Black	Navy	
S	-6200A	-6205F	2850.00
M	-6201B	-6206G	2850.00
L	-6202C	-6207H	2850.00
XL	-6203D	-6208J	2850.00
2XL	-6204E	-6209K	2850.00

Ladies Soft Shell Jackets

260gsm, two layer construction soft shell with shaped fit.
Full length zip fastening.
Two zipped side pockets.

Colours:

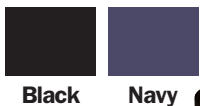

NEW



Size	Order Code SSF-962		Price/1 TB
	Black	Navy	
S	-6130C	-6134C	2250.00
M	-6130D	-6134D	2250.00
L	-6130E	-6134E	2250.00
XL	-6130F	-6134F	2250.00
2XL	-6130G	-6134G	2250.00

Ladies Soft Shell Gilets

Jet SS2LV4
260gsm, two layer soft shell construction.
Full length fastening zip. Contrast trim.
Two hip pockets and one chest pocket.

Colours: black and navy.

NEW



Size	Order Code SSF-962		Price/1 TB
	Black	Navy	
S	-6100C	-6104C	1999.00
M	-6100D	-6104D	1999.00
L	-6100E	-6104E	1999.00
XL	-6100F	-6104F	1999.00
2XL	-6100G	-6104G	1999.00

Ladies Executive Soft Shell Jackets

290gsm three layer construction with 10,000/3,000 breathable waterproof membrane. Contrast trim sleeves. Two side zipped pockets. One chest zipped pocket. One zipped arm pocket. Shaped fit.

Colours:

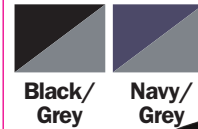

NEW



Size	Order Code TFF-962		Price/1 TB
	Navy/Grey	Black/Grey	
S	-6220A	-6225F	2850.00
M	-6221B	-6226G	2850.00
L	-6222C	-6227H	2850.00
XL	-6223D	-6228J	2850.00
2XL	-6224E	-6229K	2850.00

PERSONAL PROTECTION

CHEMICAL HAZARD CLOTHING



'Guard Master' FR™ Flame Retardant Disposable Hooded Coveralls

NEW

Disposable coveralls with hood, elastic cuffs, back and ankles. 1-way zip at front with 1-ply stormflap. Made from 55gsm SMS (spunbond-meltblown-spunbond) material with anti-static treatment and inside stitching. **CE Type 5 & 6.** Flame retardant **EN ISO 14116/08/1/0/0.** Nuclear particle **EN1073-2/02 Class 1.** **EN ISO 13982-1:2004 (Type 5).** **EN 13034:2005 +A1/2009 (Type 6).** **EN ISO 14116:2008 Index 1.** **EN 11490-5:2008 (anti-static).**

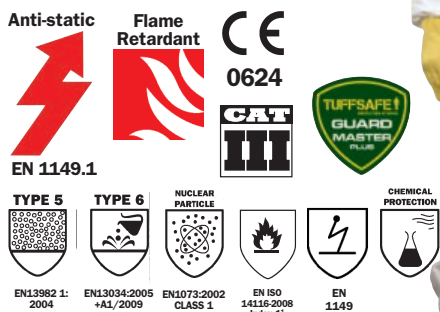

Type	Size	Order Code TFF-962	Price/1 TB
Hooded	M	-3250C	299.00
	L	-3251D	299.00
	XL	-3252E	299.00
	2XL	-3253F	299.00
	3XL	-3254G	299.00

'Guard Master' Disposable Hooded Coveralls

Type 5/6 coveralls. Disposable coveralls with hood, elastic cuffs, back and ankles. 1-way zip at front with 1-ply stormflap. Made from 55gsm SMS (spunbond, microporous spunbond) material with inside stitching. For noxious dust and splash. Ideal for dry particulate barrier and repellency. Lightweight and breathable. Liquid repellent. Designed to zip over neck to above the chin to protect exposed neck areas. **EN13034** for limited protection against liquid particles (Type 6). **EN13982-1 (Type 5)** for protection against solid particles.

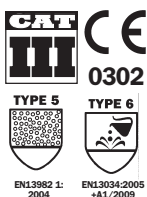

Covershoes and gloves supplied separately.

Colour	Size	Order Code TFF-962	Price/1 TB
Blue	S	-3800A	222.00
	M	-3801B	222.00
	L	-3802C	222.00
	XL	-3803D	222.00
	2XL	-3804E	222.00
White	S	-3810A	222.00
	M	-3811B	222.00
	L	-3812C	222.00
	XL	-3813D	222.00
	2XL	-3814E	222.00



Disposable Coveralls

100% polypropylene single-use disposable coverall for minimal risk and nuisance. Provides protection from non-hazardous dust and liquid splash. Designed for comfortable fit with elasticated ankles, cuffs, hood and waist. Suitable for DIY and home maintenance, food processing, general cleaning, site visitors, stores and warehouse use etc.



Overshoes supplied separately.

Colour	Size	Order Code SSF-962	Price/1 TB
Blue	M	-1250C	101.00
	L	-1250D	101.00
	XL	-1250E	101.00
	2XL	-1250F	101.00
White	M	-1253C	101.00
	L	-1253D	101.00
	XL	-1253E	101.00
	2XL	-1253F	101.00



'Guard Master PLUS' Disposable Hooded Coveralls

Type 5/6 coveralls. Non-woven disposable coveralls with elasticated hood, cuffs, back and ankles. Antistatic. Liquid repellent. Diamond crotch gusset improves manoeuvrability. 2-way zip at front with 1-ply adhesive tape stormflap. Laminated microporous film 65gsm with inside stitching. Provides protection against airborne solid particulates, liquid chemicals, infective agents, chemical and radioactive contamination. Designed to zip over neck to above the chin to protect exposed neck areas. **EN13982-1 (Type 5)** for protection against solid particles. **EN1149-5** electrostatic properties. **EN141126** for protection against infective agents. **EN1073-2** for protection against radioactive contamination. **EN13034/05** for limited protection against liquid chemicals (Type 6).



Anti-Static



Covershoes and gloves supplied separately.

Colour	Size	Order Code TFF-962	Price/1 TB
White	S	-3830A	279.00
	M	-3831B	279.00
	L	-3832C	279.00
	XL	-3833D	279.00
	2XL	-3834E	279.00

PERSONAL PROTECTION

GROUP 962 HI-VIS WORKWEAR

TUFFSAFE High Visibility Waistcoats

Manufactured to **BS EN 471**
100% polyester with velcro fastening.
All tape bands are 50mm wide.



EN471



Sizing Guide:
Fit according to chest size.
A larger size may be required if worn over clothing.

Garment Size	Chest Size - cm	Height cm
M	112-116	152-194
L	116-120	152-194
XL	120-124	152-194
XXL	124-128	152-194
XXXL	128-134	152-194

These garments comply with the requirements of Directive 89/686/EEC and the reference standards listed below.



Breathable High Visibility Coats



Certified to **EN471 Class 3**.
Certified to **EN343 Class 2** breathing fabric.
Polyester with PU coating. Concealed hood, full zip front with double storm flap.
Nylon/polyester quilt lining, self double yoke back.
Lower pockets with flap and elasticated storm cuffs. Stitched and welded seams.
Reflective material.

Breathable



EN343



EN471



Size	Weight each	Order Code TFF-962	Price/1 TB
M	1050g	-4051B	3449.00
L	1050g	-4052C	3449.00
XL	1050g	-4053D	3449.00
2XL	1050g	-4054E	3449.00

PERSONAL PROTECTION

BS EN 471 Class 3 - Yellow
1 Body Band with Braces

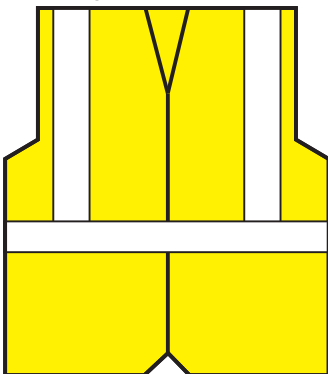

BS EN 471 Class 2 - Yellow
2 Body Bands with Braces

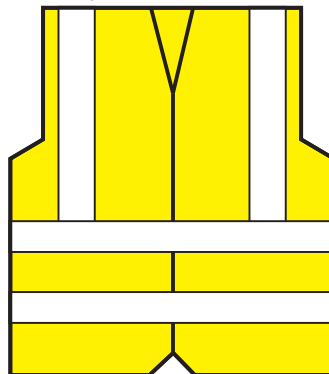

BS EN 471 Class 3 - Orange
1 Body Band with Braces

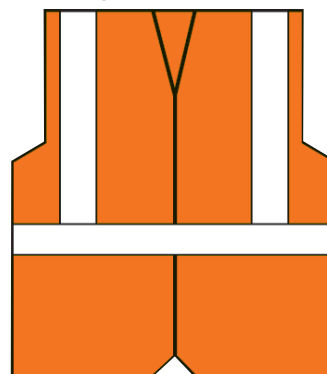

BS EN 471 Class 2 - Orange
2 Body Bands with Braces

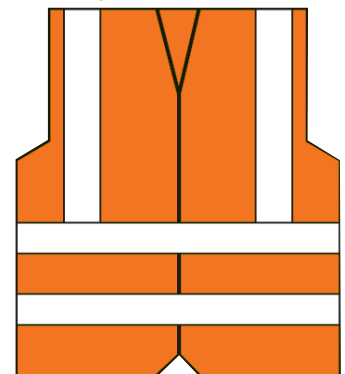

EN 471 Class	Bands Body	Braces	Size	Weight each	Order Code TFF-962	Price/1 TB
3	1	✓	M	135g	-4211B	181.00
			L	150g	-4212C	181.00
			XL	270g	-4213D	181.00
			2XL	350g	-4214E	181.00
2	2	✓	M	135g	-4231B	203.00
			L	150g	-4232C	203.00
			XL	270g	-4233D	203.00
			2XL	350g	-4234E	203.00
			3XL	350g	-4235F	203.00

EN 471 Class	Bands Body	Braces	Size	Weight each	Order Code TFF-962	Price/1 TB
3	1	✓	M	135g	-4241B	203.00
			L	150g	-4242C	203.00
			XL	270g	-4243D	203.00
			2XL	350g	-4244E	203.00
			3XL	350g	-4245F	203.00
2	2	✓	M	150g	-4251B	203.00
			L	270g	-4252C	203.00
			XL	270g	-4253D	203.00
			2XL	350g	-4254E	203.00
			3XL	350g	-4255F	203.00

TUFFSAFE High Visibility Body Warmers

Certified to **EN471 Class 2**.
 PU coating to hi-vis side.
 Reversible bodywarmer 'zipout'. Knitted collar.
 Heavy duty zip.
 Navy polycotton diamond quilt on reverse.
 Two patch pockets on quilted side.
 Reflective material.



Size	Weight each	Order Code TFF-962	Price/1 TB
M	1050g	-4711B	1597.00
L	1050g	-4712C	1597.00
XL	1050g	-4713D	1700.00
2XL	1050g	-4714E	1803.00

Hi-Vis Polo Shirt

Two reflective bands around the torso and each sleeve, one band over each shoulder meeting **EN471 Class 3/2** requirements. Lightweight and breathable polyester fabric.



Size	Order Code TFF-962	Price/1 TB
M	-4731B	567.00
L	-4732C	567.00
XL	-4733D	567.00
2XL	-4734E	567.00

Hi-Vis Sweatshirt

Two reflective bands around the torso and each sleeve, one band over each shoulder meeting **EN471 Class 3/2** requirements.



Size	Order Code TFF-962	Price/1 TB
M	-4741B	1236.00
L	-4742C	1236.00
XL	-4743D	1236.00
2XL	-4744E	1236.00

Lightweight Jackets

Satin yellow knitted polyester.

High Visibility Yellow
 All tape bands are 50mm wide.

BSEN471 1994: Class 3 area of fluorescent background and retro reflective tape.

BSEN471 1994: Class 2 retro reflective tape performance.



Available Sizes & Selection:
 Fit according to chest size. A larger size may be required if worn over clothing.

Sizing Guide		
Size	Chest (cms)	Height
M	112-116	152-194
L	116-120	152-194
XL	120-124	152-194
2XL	124-128	152-194

CE These garments comply with the requirements of Directive **89/686/EEC** and the above reference standards.

Bands	Size	Weight each	Order Code TFF-962	Price/1 TB
2	✓	M 150g	-4411B	335.00
2	✓	L 200g	-4412C	335.00
2	✓	XL 300g	-4413D	335.00
2	✓	2XL 400g	-4414E	335.00

Hi-Vis Executive Vest

Two reflective bands around the torso and one band over each shoulder meeting **EN471 Class 2/2** requirements. Lightweight and breathable vest. Zip front. External mobile phone pocket, pen pouch, 'D' ring and clear ID pouch. Two pockets with velcro fastening.



Size	Order Code TFF-962	Price/1 TB
M	-4721B	409.00
L	-4722C	409.00
XL	-4723D	409.00
2XL	-4724E	409.00

Hi-Vis Fleece Jacket

Two reflective bands around the torso and each sleeve, one band over each shoulder meeting **EN471 Class 3/2** requirements. Fleece comes with mesh inner lining, elasticated cuffs and two side entry pockets.



Size	Order Code TFF-962	Price/1 TB
M	-4751B	1906.00
L	-4752C	1906.00
XL	-4753D	1906.00
2XL	-4754E	1906.00

PERSONAL PROTECTION

GROUP 962 HI-VIS WORKWEAR

TUFFSAFE 5-in-1 High Visibility Waterproof & Breathable Coats

A multi-function coat system for all seasons. An outer layer, detachable inner jacket, detachable inner sleeves and detachable hood giving multiple wear options to suit any weather conditions.

Outer Layer: Two reflective bands around the torso and each sleeve, one band over each shoulder meeting **EN471 Class 3/3** requirements and **EN343 Class 3/3**. Two way zip with press stud storm flap protection. Fully taped seams. Fleece collar. External phone pocket and clear ID pouch. Two 'D' rings. Zip security pocket within the storm flap for easy access. Two external pockets with pop stud fastening plus two side slant pockets for easy access. Adjustable Velcro cuff straps. Inner layer retained by zips and press studs. Zip access to shell for corporate identity/branding. Adjustable drawstring toggles on waist and hood.

Inner Layer/Body Warmer:

Two reflective bands around the torso, one band over each shoulder meeting **EN471 class 3/2** requirements. Dual purpose inner layer with reflective properties and inner quilted option when reversed. Fully taped seams. Two way zipper for attaching to outer layer or wearing independently. Fleece collar. External phone pocket with 'D' ring. Two external side pockets on both hi-vis and quilted layer. Elasticated cuffs. Removable zipped sleeves to create body warmer.



These garments comply with the requirements of Directive 89/686/EEC and the above reference standards.

Size	Order Code TFF-962	Price/1 TB
S	-8010A	4119.00
M	-8011B	4119.00
L	-8012C	4119.00
XL	-8013D	4119.00
2XL	-8014E	4119.00



Breathable High Visibility Trousers



Certified to **EN471**. Breathable fabric. Polyester with PU coating. Overtrousers with elasticated waist. Studded ankles. Reflective material.



EN471

Breathable



Size	Weight each	Order Code TFF-962	Price/1 TB
M	1050g	-4061B	1539.00
L	1050g	-4062C	1539.00
XL	1050g	-4063D	1539.00
2XL	1050g	-4064E	1539.00

Waterproof High Visibility Trousers

Satin yellow knitted polyester lightweight overtrousers with elasticated waist, velcro front fastening and fully taped waterproof seams. Complete with two 50mm reflective bands around each leg.

PREN343 1993:

Class 3 (highest) water penetration; Class 1 (lowest) water vapour resistance.

BSEN471 1994:

Class 1 area of fluorescent background and retro reflective tape.

BSEN471 1994: Class 2 retro reflective tape performance.

Yellow

'Hi-Vis' Orange

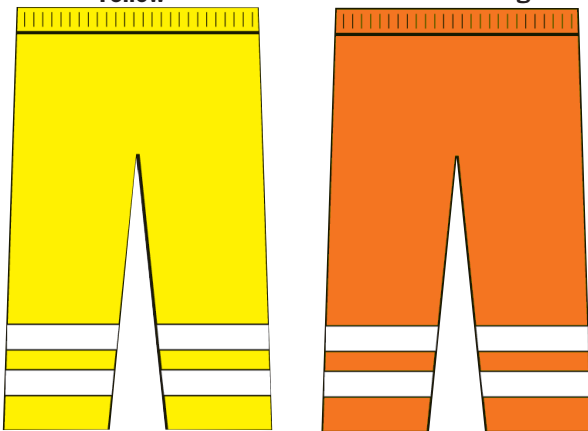

EN343 EN471

Waterproof



These garments comply with the requirements of Directive 89/686/EEC and the above reference standards.

Colour	Size	Weight each	Order Code TFF-962	Price/1 TB
Yellow	M	330g	-4021B	943.00
	L	350g	-4022C	943.00
	XL	360g	-4023D	943.00
	2XL	370g	-4024E	943.00
Orange	M	330g	-4041B	943.00
	L	350g	-4042C	943.00
	XL	360g	-4043D	943.00
	2XL	370g	-4044E	943.00

Available Sizes & Selection:

Fit according to waist size. This garment has a 20cm allowance built in for comfort and to allow the garment to be worn over light layers of clothing. If bulkier clothing has to be worn underneath, a larger size may be required.

Sizing Guide

Size	Waist (ins)	Waist (cms)	Height
M	32-34	80-84	170-176
L	34-36	88-92	176-182
XL	36-38	82-96	182-188
2XL	40-42	100-104	188-194

PERSONAL PROTECTION

TUFFSAFE Waterproof High Visibility Jackets

Two hip pockets with velcro fastened flaps. Drawstring hood. Knitted storm cuffs. Two way zip front with studded storm flap. Inside pocket.

PREN343 1993:

Class 3 (highest) water penetration;
Class 1 (lowest) water vapour resistance.

BSEN471 1994:

Class 3 area of fluorescent background and retro reflective tape.

BSEN471 1994:

Class 2 retro reflective tape performance.

Available Sizes & Selection:

Fit according to chest size. This garment has a 20cm allowance built in for comfort and to allow the garment to be worn over light layers of clothing. If bulkier clothing has to be worn underneath, a larger size may be required.



EN343 EN471

Size	Sizing Guide		Height
	Chest (ins)	Chest (cms)	
M	37-39	92-100	170-176
L	39-43	100-108	176-182
XL	43-46	108-116	182-188
2XL	46-49	116-124	188-194

These garments comply with the requirements of Directive 89/686/EEC and the above reference standards.

Bands		Size	Weight each	Order Code TFF-962	Price/1 TB
Body	Braces				
2	✓	M	1.4kg	-4111B	1803.00
2	✓	L	1.4kg	-4112C	1803.00
2	✓	XL	1.4kg	-4113D	1803.00
2	✓	2XL	1.4kg	-4114E	1803.00

Waterproof



Waterproof High Visibility Coats

Satin yellow PU coated polyester with fixed nylon quilted lining. Two internal breast pockets, two exterior pockets with storm flaps and rear access for corporate identity logo heat attachment. Heavy weight two way zip with studded storm flap knitted storm cuffs, concealed hood with drawstring. Fully taped seams. All highway jackets have 2x 50mm sleeve bands. Uses 3M Scotchlite retro-reflective glass bead tape.

PREN343 1993:

Class 3 (highest) water penetration; Class 1 (lowest) water vapour resistance.

BSEN471 1994:

Class 3 area of fluorescent background and retro reflective tape.

BSEN471 1994:

Class 2 retro reflective tape performance.



EN343 EN471

Available Sizes & Selection:

Fit according to chest size. This garment has a 20cm allowance built in for comfort and to allow the garment to be worn over light layers of clothing. If bulkier clothing has to be worn underneath, a larger size may be required.

Sizing Guide

Size	Sizing Guide		Height
	Chest (ins)	Chest (cms)	
M	37-39	92-100	170-176
L	39-43	100-108	176-182
XL	43-46	108-116	182-188
2XL	46-49	116-124	188-194

Yellow

All tape bands are 50mm wide.

Waterproof



These garments comply with the requirements of Directive 89/686/EEC and the above reference standards.

Bands		Size	Weight each	Order Code TFF-962	Price/1 TB
Body	Braces				
2	✓	M	0.9kg	-4011B	1906.00
2	✓	L	1.0kg	-4012C	1906.00
2	✓	XL	1.0kg	-4013D	1906.00
2	✓	2XL	1.2kg	-4014E	1906.00

Orange

All tape bands are 50mm wide.

Waterproof



These garments comply with the requirements of Directive 89/686/EEC and the above reference standards.

Bands		Size	Weight each	Order Code TFF-962	Price/1 TB
Body	Braces				
2	✓	M	0.9kg	-4031B	1906.00
2	✓	L	1.0kg	-4032C	1906.00
2	✓	XL	1.0kg	-4033D	1906.00
2	✓	2XL	1.2kg	-4034E	1906.00

PRODUCTS ARE ONLY AVAILABLE VIA YOUR DISTRIBUTOR

Foot Protection

The wearing of foot protection in hazardous areas is a requirement under regulation 4 of the **Personal Protective Equipment at Work Regulations 1992**. This regulation requires employers to provide suitable personal protective equipment to employees exposed to health and safety risks. Feet need to be protected from hazards such as wet, electrostatic build-up, slipping, cuts and punctures, falling objects, metal and chemical splash and abrasion.

Note: Footwear can have a variety of sole patterns and materials to prevent slips in different conditions, have oil or chemical-resistant soles, and be antistatic, electrically conductive or insulating. There are a variety of styles including 'trainers' and boots with ankle support.

Footwear Classification System - A Brief Guide

S3 {	S2 {	S1 {	SB {	Safety Basic to EN ISO 20345 200 Joules Toe Protection. Anti-static and Energy Absorbing Heel. Water-Resistant Upper. Steel Midsole.	SBP {	For Class S1 and SB with Steel Midsole S1P and SBP classification is used).
	S5 {	S4 {		Safety Basic to EN ISO 20345 200 Joules Toe Protection. All rubber or all polymeric footwear with Antistatic and Energy Absorbing Heel. Water-resistant Upper and Steel Midsole.		



200 Joules steel toe cap impact protection. Guards against falling objects and collisions (unless stated).



Oil, petrol, water, acid and alkali resistant.



Water penetration and absorption resistant. Helps keep feet dry in wet conditions.



Steel midsole to prevent sharp object penetration. Ideally suited to building sites and where metal swarf is present on floors.



Resists the build-up and conductance of static electricity. Of most benefit when walking on synthetic carpets or near electrical machinery.



Lightweight. Normally polyurethane soles with breathable uppers. Reduces fatigue during extended wear.



Non-metallic protection Kevlar composite toe cap and sole plate. For working in areas where security screening is a necessity. 200 Joules impact protection (unless stated).



Dual density polyurethane/rubber soles for extra comfort. The sole features a nitrile rubber outsole, resistant to heat to 300° and a low density polyurethane interlayer, for increased comfort and shock absorption.



Specially shaped inner sole to support arches and toes.



Normally allows walking on hot surfaces up to 300°C (unless stated).



Wider fitting for extra comfort. Also allows the user to wear thick work socks.

NOTE:

Most shoe companies do not use absolutely correct size conversions and so it is quite common to have some variation from these tables. The table represents the 'best fit' solution i.e. calibrated to the nearest size to its counterpart.

Sizing Guide (Sizes are not standard)

UK	3	4	5	6	7	8	9	10	11	12	13
Continental	36	37	38	39½	40½	42	43	44½	45½	47	48
Asia	22	23	24	25	26	27	28	29	30	31	32
USA (Men)	4	5	6	7	8	9	10	11	12	13	14
(Women)	4½	5½	6½	7½	8½	9½	10½	11½	12½		

PERSONAL PROTECTION

TUFFSAFE **Mid-Cut Safety Boots**
Steel Midsole

BWB 08

Manufactured to **EN345**. Dual density, anti-static and energy absorbing heel. Water-resistant upper, waterproof and breathable lining with a steel midsole. 200 joules toe protection.

Colour: black.

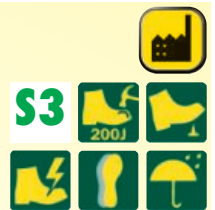
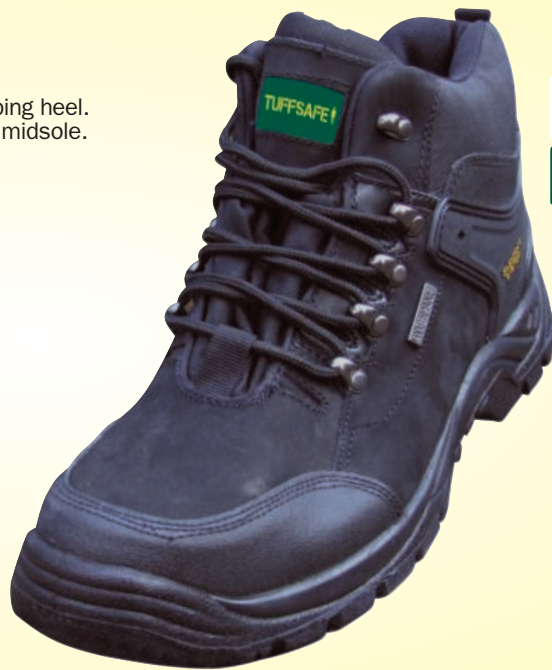

Size	Order Code
	TFF-963
6	-0806D
7	-0807E
8	-0808F
9	-0809G
10	-0810H
11	-0811J
12	-0812K
Price/Pair	
TB	
3863.00	

TUFFSAFE Rigger Boots

Tuffsafe Rigger boots are a pull-on safety boot popular with tradesmen and construction workers, designed to cope with the demanding working conditions found in most outdoor on-site environments. Tuffsafe Rigger boots are the ideal safety footwear for winter weather as they go a third of the way up the leg this keeps your feet dry and the bottom of your trousers clean as you can tuck them in the top of the boot. Lined rigger boots are tough on the outside, soft and warm on the inside, they have been manufactured to provide comfort and safety when worn all day, in the most challenging weather conditions you'll encounter on-site.

Fur Lined Rigger Boots**RAT 08**

Manufactured to **EN ISO 20345:2011**. 200J steel toecap. Steel midsole. Anti-static dual density polyurethane/rubber sole. Water penetration and absorption resistant. Oil, petrol, water, acid and alkali resistant.

Colour: tan.



Size	Order Code
	TFF-963
5	-1245C
6	-1246D
7	-1247E
8	-1248F
9	-1249G
10	-1250H
11	-1251J
12	-1252K

Price/Pair
TB
1545.00

S5**Lined Steel Midsole Rigger Boots****RAT 06**

Manufactured to **EN345**. 200 joules steel toecap, steel midsole, antistatic dual density polyurethane/rubber sole, temperature-resistant up to 200°C with energy absorbing heels for extra comfort.

Colour: tan.

RAT 06

Fur-lining.

Size	Order Code
	TFF-963
6	-0606D
7	-0607E
8	-0608F
9	-0609G
10	-0610H
11	-0611J
12	-0612K

Price/Pair
TB
2750.00

**S1P****6" Safety Boots****BAB 04**

These leather safety boots from the Tuffsafe premier safety footwear range incorporate hard wearing dual density polyurethane anti-static soles for your comfort. They have steel midsoles and are heat-resistant to 200°C with 200 joules steel toe protection for your safety.

Manufactured to **EN345**.

Colour: black.



Size	Order Code
	TFF-963
6	-0420D
7	-0421E
8	-0422F
9	-0423G
10	-0424H
11	-0425J
12	-0426K

Price/Pair
TB
2009.00

S1P**SITESAFE** Safety Wellingtons

Black. Energy absorbing heel. Tough construction. Manufactured to **EN ISO 345**.

Size	Order Code
	SSF-963
3	-2003K
4	-2004K
5	-2005K
6	-2006K
7	-2007K
8	-2008K
9	-2009K
10	-2010K
11	-2011K
12	-2012K

Price/Pair
TB
926.00

**S5**

PERSONAL PROTECTION



Nubuck Weltd Safety Boots Steel Midsole

BBH 01

Manufactured to **EN345**. Goodyear welt construction. Ultra flexible and lightweight sole. Steel midsole. 200 joules toe protection.

Colour: honey.



Size	Order Code
	TFF-963
6	-0106D
7	-0107E
8	-0108F
9	-0109G
10	-0110H
11	-0111J
12	-0112K

Price/Pair
TB
3657.00

SBP



Weltd Safety Boots Steel Midsole

BBB 02

Manufactured to **EN345**. Goodyear Welt construction. Ultra flexible and lightweight sole. Steel midsole. Heat-resistant to 300°C. 200 joules toe protection.

Colour: black.



Size	Order Code
	TFF-963
6	-0206D
7	-0207E
8	-0208F
9	-0209G
10	-0210H
11	-0211J
12	-0212K

Price/Pair
TB
3502.00



SBP



Nubuck Hiker Safety Boots

BBH 03

Manufactured to **EN345**. Cemented construction, lightweight rubber sole. Heat resistant to 200°C. 200 joules toe protection.

Colour: honey.



Size	Order Code
	TFF-963
6	-0320D
7	-0321E
8	-0322F
9	-0323G
10	-0324H
11	-0325J
12	-0326K

Price/Pair
TB
2574.00

SB



SITESAFE Safety Boots

SSF01

Steel toe and midsole chukka boot/shoe, split leather upper, antistatic properties, dual density PU/PU outsole, padded collar for extra support, padded tongue for extra comfort, lightweight and flexible, S1P specification, fully conforming to **EN ISO 345** Standards.

Colour: black.



Size	Order Code
	SSF-963
3	-2203K
4	-2204K
5	-2205K
6	-2206K
7	-2207K
8	-2208K
9	-2209K
10	-2210K
11	-2211K
12	-2212K
13	-2213K

Price/Pair
TB
1236.00



S1P



SITESAFE Safety Boots

SSF05

Manufactured to **EN345**. 200J steel toecap. Steel midsole. Oil, petrol, water acid and alkali resistant. Anti-static. Dual density polyurethane rubber soles.

Size	Order Code
	SSF-963
5	-1960K
6	-1961K
7	-1962K
8	-1963K
9	-1964K
10	-1965K
11	-1966K
12	-1967K

Price/Pair
TB
1803.00



S1P



PERSONAL PROTECTION



Safety Shoes Steel Midsole

SWB 07

Black. Manufactured to **EN345**. Anti-static and energy absorbing heel. Dual density polyurethane rubber sole. Water-resistant upper and steel midsole. Heat-resistant to 300°C. 200 joules toe protection.

Size	Order Code
	TFF-963
6	-0706D
7	-0707E
8	-0708F
9	-0709G
10	-0710H
11	-0711J
12	-0712K

Price/Pair
TB
3863.00



S3



Safety Trainers

CST 10

Manufactured to **EN ISO 345**. Using the latest materials such as Kevlar and composite technologies. PU and leather upper, EVA/RB outsole.

Size	Order Code
	TFF-963
6	-0850D
7	-0851E
8	-0852F
9	-0853G
10	-0854H
11	-0855J
12	-0856K

Price/Pair
TB
3193.00



SIP



Safety Ankle Boots

CAB 09

Using the latest materials such as Kevlar and composite technologies. PU and leather upper, EVA/RB outsole. Manufactured to **EN ISO 345**.

Size	Order Code
	TFF-963
6	-0150D
7	-0151E
8	-0152F
9	-0153G
10	-0154H
11	-0155J
12	-0156K

Price/Pair
TB
3451.00



SIP



Non-Metallic Safety Boots

BNM11

Black/grey. Manufactured to **EN ISO 20345:2011**. 200J toecap. Midsole. Waterproof for dry feet in wet conditions. Dual density soles.

Size	Order Code
	TFF-963
6	-0906D
7	-0907E
8	-0908F
9	-0909G
10	-0910H
11	-0911J
12	-0912K

Price/Pair
TB
3348.00

NEW



S3



Non-Metallic Safety Trainers

TNM12

Black/grey. Manufactured to **EN ISO 20345:2011**. 200J toecap. Midsole. Waterproof for dry feet in wet conditions. Dual density soles.

Size	Order Code
	TFF-963
6	-0936D
7	-0937E
8	-0938F
9	-0939G
10	-0940H
11	-0941J
12	-0942K

Price/Pair
TB
3193.00

NEW



S3



Safety Shoes

SSF02

Black. Steel toe and midsole chukka boot/shoe, split leather upper, anti-static properties, dual density PU/PU outsole, padded collar for extra support, padded tongue for extra comfort, lightweight and flexible, S1P specification, fully conforming to **EN ISO 345** Standards.

Size	Order Code
	SSF-963
3	-2243K
4	-2244K
5	-2245K
6	-2246K
7	-2247K
8	-2248K
9	-2249K
10	-2250K
11	-2251K
12	-2252K
13	-2253K

Price/Pair
TB
1133.00



SIP



Safety Trainers

SSF04

Manufactured to **EN345**. 200J steel toecap. Steel midsole. Oil, petrol, water acid and alkali resistant. Anti-static. Dual density polyurethane/rubber soles.

Size	Order Code
	SSF-963
5	-1950K
6	-1951K
7	-1952K
8	-1953K
9	-1954K
10	-1955K
11	-1956K
12	-1957K

Price/Pair
TB
2059.00



SIP



PERSONAL PROTECTION



TUFFSAFE 

INGRESS PROTECTION (IP) RATINGS

Ingress Protection (IP) Ratings

Ingress Protection (IP) ratings are developed by the **European Committee for Electro Technical Standardization (CENELEC)** (described IEC/EN 60529), specify the environmental protection an enclosure provides. In order to comply with stringent requirements for **CE Marking**, machine makers today are fitting their machines with parts that are certified according to **EU (European Union)** and international standards.

The IP rating normally has two (or three) numbers:

IP First Number - Protection from solid objects or materials

IP Second Number - Protection from liquids

IP Third Number - Protection against mechanical impacts
(commonly omitted)

Example - IP Rating



5 describes the level of protection from solid objects and **4** describes the level of protection from liquids.

1

Protection against solid objects

- 0** No protection.
- 1** Protected against solid objects up to 50mm, e.g. accidental touch by hands.
- 2** Protected against solid objects up to 12mm, e.g. fingers.
- 3** Protected against solid objects over 2.5mm (tools and wires).
- 4** Protected against solid objects over 1mm (tools, wire, and small wires).
- 5** Protected against dust limited ingress (no harmful deposit).
- 6** Totally protected against dust.

2

Protection against liquids

- 0** No protection.
- 1** Protection against vertically falling drops of water e.g. condensation.
- 2** Protection against direct sprays of water up to 15° from the vertical.
- 3** Protected against direct sprays of water up to 60° from the vertical.
- 4** Protection against water sprayed from all directions ° limited ingress permitted.
- 5** Protected against low pressure jets of water from all directions ° limited ingress.
- 6** Protected against low pressure jets of water, e.g. for use on ship decks - limited ingress permitted.
- 7** Protected against the effect of immersion between 15cm and 1m.
- 8** Protects against long periods of immersion under pressure.

3

Protection against mechanical impacts (commonly omitted)

- 0** No protection.
- 1** Protects against impact of 0.225 joule (e.g. 150g weight falling from 15cm height).
- 2** Protected against impact of 0.375 joule (e.g. 250g weight falling from 15cm height).
- 3** Protected against impact of 0.5 joule (e.g. 250g weight falling from 20cm height).
- 4** Protected against impact of 2.0 joule (e.g. 500g weight falling from 40cm height).
- 5** Protected against impact of 6.0 joule (e.g. 1.5kg weight falling from 40cm height).
- 6** Protected against impact of 20.0 joule (e.g. 5kg weight falling from 40cm height).



PRODUCTS ARE ONLY AVAILABLE VIA YOUR DISTRIBUTOR

CONVERSIONS Fraction, Millimetre, Gauge, Inch

CONVERSIONS				Fraction • Millimetre • Gauge • Inch			
Fraction	Millimetre	Gauge	Inch	Fraction	Millimetre	Gauge	Inch
30	0.118		0.420	1/8	1.067	58	0.420
32	0.125		0.430	1/8	1.092	57	0.430
34	0.132	80	0.443	1/8	1.125		0.453
36	0.138		0.456	1/8	1.181	56	0.465
38	0.145	79	0.469	1/8	1.191		0.469
40	0.152		0.482	1/8	1.20		0.477
42	0.159		0.495	1/8	1.20		0.492
44	0.166	78	0.508	1/8	1.30		0.512
46	0.173		0.521	1/8	1.321	55	0.520
48	0.180		0.534	1/8	1.35		0.531
50	0.188	77	0.547	1/8	1.37	54	0.550
52	0.195		0.560	1/8	1.40		0.551
54	0.202		0.573	1/8	1.45		0.571
56	0.210		0.586	1/8	1.50		0.591
58	0.217		0.599	1/8	1.511	53	0.595
60	0.225	75	0.612	1/8	1.55		0.610
62	0.232		0.625	1/8	1.598		0.625
64	0.240		0.638	1/8	1.60		0.630
66	0.247		0.651	1/8	1.613	52	0.635
68	0.255	74	0.664	1/8	1.65		0.650
70	0.262		0.677	1/8	1.70		0.669
72	0.270		0.690	1/8	1.70	51	0.670
74	0.277		0.703	1/8	1.778	50	0.700
76	0.285		0.716	1/8	1.80		0.709
78	0.292		0.729	1/8	1.85		0.728
80	0.300	71	0.742	1/8	1.854	49	0.730
82	0.307		0.755	1/8	1.80		0.748
84	0.315		0.768	1/8	1.90		0.748
86	0.322		0.781	1/8	1.90		0.760
88	0.330		0.794	1/8	1.95	48	0.760
90	0.337		0.807	1/8	1.984		0.781
92	0.345		0.820	1/8	1.994	47	0.781
94	0.352		0.833	1/8	2.00		0.787
96	0.360		0.846	1/8	2.05		0.807
98	0.367		0.859	1/8	2.057	46	0.810
100	0.375		0.872	1/8	2.083	45	0.820
102	0.382		0.885	1/8	2.15		0.846
104	0.390		0.898	1/8	2.184	44	0.860
106	0.397		0.911	1/8	2.20		0.866
108	0.405		0.924	1/8	2.25		0.886
110	0.412		0.937	1/8	2.261	43	0.890
112	0.420		0.950	1/8	2.30		0.906
114	0.427		0.963	1/8	2.35		0.925
116	0.435		0.976	1/8	2.375	42	0.935
118	0.442		0.989	1/8	2.381		0.938
120	0.450		1.002	1/8	2.40		0.945
122	0.457		1.015	1/8	2.438	41	0.965
124	0.465		1.028	1/8	2.45		0.965
126	0.472		1.041	1/8	2.489	40	0.980
128	0.480		1.054	1/8	2.50		0.984
130	0.487		1.067	1/8	2.525	39	0.994
132	0.495		1.080	1/8	2.55		1.004

CONVERSIONS				Fraction • Millimetre • Gauge • Inch			
Fraction	Millimetre	Gauge	Inch	Fraction	Millimetre	Gauge	Inch
1/16	1.588		0.0625	1/16	1.588		0.0625
1/8	3.175		0.125	1/8	3.175		0.125
3/16	4.763		0.1875	3/16	4.763		0.1875
1/4	6.35		0.25	1/4	6.35		0.25
5/16	7.938		0.3125	5/16	7.938		0.3125
3/8	9.525		0.375	3/8	9.525		0.375
7/16	11.113		0.4375	7/16	11.113		0.4375
1/2	12.7		0.5	1/2	12.7		0.5
9/16	14.288		0.5625	9/16	14.288		0.5625
5/8	15.875		0.625	5/8	15.875		0.625
11/16	17.463		0.6875	11/16	17.463		0.6875
3/4	19.05		0.75	3/4	19.05		0.75
7/8	20.638		0.8125	7/8	20.638		0.8125
1 1/8	22.225		0.875	1 1/8	22.225		0.875
1 1/4	23.813		0.9375	1 1/4	23.813		0.9375
1 3/8	25.4		1.0	1 3/8	25.4		1.0
1 1/2	27.988		1.0625	1 1/2	27.988		1.0625
1 5/8	29.575		1.125	1 5/8	29.575		1.125
1 3/4	31.163		1.1875	1 3/4	31.163		1.1875
1 7/8	32.75		1.25	1 7/8	32.75		1.25
2	35.338		1.3125	2	35.338		1.3125
2 1/8	36.925		1.375	2 1/8	36.925		1.375
2 1/4	38.513		1.4375	2 1/4	38.513		1.4375
2 3/8	40.1		1.5	2 3/8	40.1		1.5
2 1/2	41.688		1.5625	2 1/2	41.688		1.5625
2 5/8	43.275		1.625	2 5/8	43.275		1.625
2 3/4	44.863		1.6875	2 3/4	44.863		1.6875
2 7/8	46.45		1.75	2 7/8	46.45		1.75
3	48.038		1.8125	3	48.038		1.8125
3 1/8	49.625		1.875	3 1/8	49.625		1.875
3 1/4	51.213		1.9375	3 1/4	51.213		1.9375
3 3/8	52.8		2.0	3 3/8	52.8		2.0
3 1/2	54.388		2.0625	3 1/2	54.388		2.0625
3 5/8	55.975		2.125	3 5/8	55.975		2.125
3 3/4	57.563		2.1875	3 3/4	57.563		2.1875
3 7/8	59.15		2.25	3 7/8	59.15		2.25
4	60.738		2.3125	4	60.738		2.3125
4 1/8	62.325		2.375	4 1/8	62.325		2.375
4 1/4	63.913		2.4375	4 1/4	63.913		2.4375
4 3/8	65.5		2.5	4 3/8	65.5		2.5
4 1/2	67.088		2.5625	4 1/2	67.088		2.5625
4 5/8	68.675		2.625	4 5/8	68.675		2.625
4 3/4	70.263		2.6875	4 3/4	70.263		2.6875
4 7/8	71.85		2.75	4 7/8	71.85		2.75
5	73.438		2.8125	5	73.438		2.8125
5 1/8	75.025		2.875	5 1/8	75.025		2.875
5 1/4	76.613		2.9375	5 1/4	76.613		2.9375
5 3/8	78.2		3.0	5 3/8	78.2		3.0
5 1/2	79.788		3.0625	5 1/2	79.788		3.0625
5 5/8	81.375		3.125	5 5/8	81.375		3.125
5 3/4	82.963		3.1875	5 3/4	82.963		3.1875
5 7/8	84.55		3.25	5 7/8	84.55		3.25
6	86.138		3.3125	6	86.138		3.3125
6 1/8	87.725		3.375	6 1/8	87.725		3.375
6 1/4	89.313		3.4375	6 1/4	89.313		3.4375
6 3/8	90.9		3.5	6 3/8	90.9		3.5
6 1/2	92.488		3.5625	6 1/2	92.488		3.5625
6 5/8	94.075		3.625	6 5/8	94.075		3.625
6 3/4	95.663		3.6875	6 3/4	95.663		3.6875
6 7/8	97.25		3.75	6 7/8	97.25		3.75
7	98.838		3.8125	7	98.838		3.8125
7 1/8	100.425		3.875	7 1/8	100.425		3.875
7 1/4	102.013		3.9375	7 1/4	102.013		3.9375
7 3/8	103.6		4.0	7 3/8	103.6		4.0
7 1/2	105.188		4.0625	7 1/2	105.188		4.0625
7 5/8	106.775		4.125	7 5/8	106.775		4.125
7 3/4	108.363		4.1875	7 3/4	108.363		4.1875
7 7/8	109.95		4.25	7 7/8	109.95		4.25
8	111.538		4.3125	8	111.538		4.3125
8 1/8	113.125		4.375	8 1/8	113.125		4.375
8 1/4	114.713		4.4375	8 1/4	114.713		4.4375
8 3/8	116.3		4.5	8 3/8	116.3		4.5
8 1/2	117.888		4.5625	8 1/2	117.888		4.5625
8 5/8	119.475		4.625	8 5/8	119.475		4.625
8 3/4	121.063		4.6875	8 3/4	121.063		4.6875
8 7/8	122.65		4.75	8 7/8	122.65		4.75
9	124.238		4.8125	9	124.238		4.8125
9 1/8	125.825		4.875	9 1/8	125.825		4.875
9 1/4	127.413		4.9375	9 1/4	127.413		4.9375
9 3/8	129.0		5.0	9 3/8	129.0		5.0
9 1/2	130.588		5.0625	9 1/2	130.588		5.0625
9 5/8	132.175		5.125	9 5/8	132.175		5.125
9 3/4	133.763		5.1875	9 3/4	133.763		5.1875
9 7/8	135.35		5.25	9 7/8	135.35		5.25
10	136.938		5.3125	10	136.938		5.3125
10 1/8	138.525		5.375	10 1/8	138.525		5.375
10 1/4	140.113		5.4375	10 1/4	140.113		5.4375
10 3/8	141.7		5.5	10 3/8	141.7		5.5
10 1/2	143.288		5.5625	10 1/2	143.288		5.5625
10 5/8	144.875		5.625	10 5/8	144.875		5.625
10 3/4	146.463		5.6875	10 3/4	146.463		5.6875
10 7/8	148.05		5.75	10 7/8	148.05		5.75
11	149.638		5.8125	11	149.638		5.8125
11 1/8	151.225		5.875	11 1/8	151.225		5.875
11 1/4	152.813		5.9375	11 1/4	152.813		5.9375
11 3/8	154.4		6.0	11 3/8	154.4		6.0
11 1/2	155.988		6.0625	11 1/2	155.988		6.0625
11 5/8	157.575		6.125	11 5/8	157.575		6.125
11 3/4	159.163		6.1875	11 3/4	159.163		6.1875
11 7/8	160.75		6.25	11 7/8	160.75		6.25
12	162.338		6.3125	12	162.338		6.3125
12 1/8	163.925		6.375	12 1/8	163.925		6.375
12 1/4	165.513		6.4375	12 1/4	165.513		6.4375
12 3/8	167.1		6.5	12 3/8	167.1		6.5
12 1/2	168.688		6.5625	12 1/2	168.688		6.5625
12 5/8	170.275		6.625	12 5/8	170.275		6.625
12 3/4	171.863		6.6875	12 3/4	171.863		6.6875
12 7/8	173.45		6.75	12 7/8	173.45		6.75
13	175.038		6.8125	13	175.038		6.8125
13 1/8	176.625		6.875	13 1/8	176.625		6.875
13 1/4	178.213		6.9375	13 1/4	178.213		6.9375
13 3/8	179.8		7.0	13 3/8	179.8		7.0
13 1/2	181.388		7.0625	13 1/2	181.388		

Engineers Reference Data Charts

Now with 38 pages of engineering data. Each page coated with an anti-glare matt lamination to protect against the dirt and grease encountered in workshop conditions.

Contents:

- Basic forms of heat treatment**
Colour charts for tempering and for hardening & forging.
- Material groups**
Colour coded machineability chart and hardness listing.
- Tensile strength and hardness**
Shore hardness and equivalent tensile strengths and conversions included.
- Lubricant selection**
Colour coded materials chart and dilution guidelines.
- Hole and shaft tolerances**
H7-e8 tolerances for counterbores included.
- Metric screw and hole sizes**
- Thread notation**
Explains terminology used to define thread characteristics.
- Standard thread forms;**
Sequenced logically, tapping and clearance sizes integrated into single chart and colour highlighted for quick reference. Includes special metric pitches & NPT, distinctions made between 'Rp' and 'G' series BSP. ISO 529 pitch form diagrams shown. Now also lists tapping and clearance drill sizes for fluteless tap.
- Dimensions of common shank types**
Now includes screwed shank, Weldon, DIN Taper, BT Taper, ISO Taper in addition to Morse taper shank details.
- Standards for engineering drawings**
Comprehensive listing including contemporary listings and illustrations.
- Abbreviations used in engineering drawings**
- Common CNC codes**
Comprehensive listing including contemporary listings.
- Axis nomenclature for machine tools**
Newly added page explaining the use of letter addresses to define directional motion.
- Trigonometry formulae**
Colour coded CAD produced illustrations for quick reference.
- Sines and Cosines**
Calculated to six decimal places with colour coded axes for quick reference.

FOURTH EDITION
Extended Content Version

"WIRO" BOUND

LAMINATED EDITION

Pocket Size
164 x 84mm

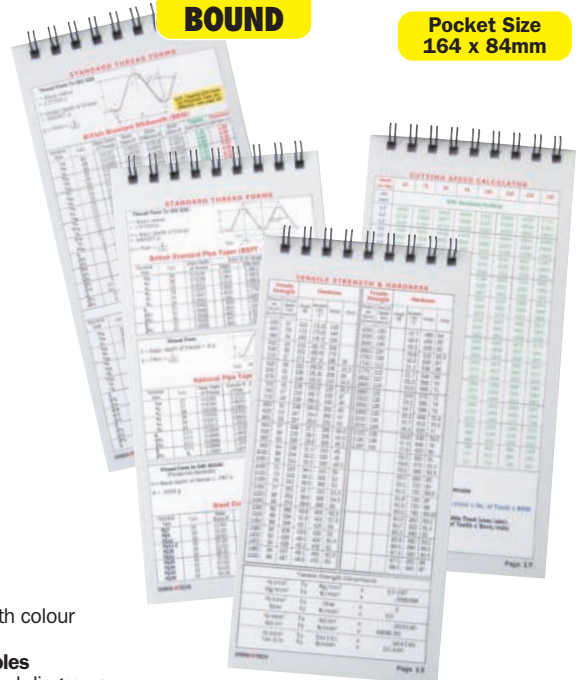

- Tangents and Cotangents**
Calculated to six decimal places with colour coded axes for quick reference.
- Co-ordinates for equally pitched holes**
Clear and easy to read CAD produced diagrams.
- Bending allowances for malleable materials**
Listed as metric radius and thickness with nearest equivalent SWG given for guidance. Clear and easy to read CAD produced diagrams.
- Cutting speed calculator**
Gives required RPM for known cutter diameters and cutting speeds.
- Standard drill size conversions;**
No & letter sizes integrated into a single chart, standard sizes are highlighted in bold text, size range extended from 25.25mm up to 32.50mm. All inch-fractional sizes converted to mm equivalent as well as inch-decimal and Morse Taper shank sizes are indicated against drill diameter ranges.

- Abbreviations and formulae**
Definitions of standard meanings with specific attention given to turning, milling and drilling. Comprehensive list of commonly used abbreviations.
- Weight and measure systems, useful conversions and constants**
A comprehensive listing of contemporary and old systems, along with the necessary conversion formulae.

Item	Order Code CAT-849	Price/1 TB
Data Charts	-2621A	155.00

Engineers Reference Handbook

- A handy pocket-sized reference booklet of data charts and tables
- Suitable for the drawing office, toolroom or workshop
- 9 sections
- 209 pages

Pocket Size
148 x 100mm

DESK EDITION

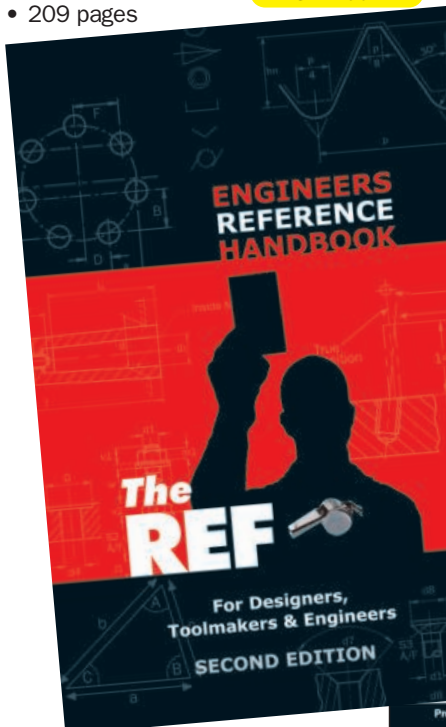

Item	Order Code CAT-849	Price/1 TB
Handbook	-0356A	202.00

PRODUCTS ARE ONLY AVAILABLE VIA YOUR DISTRIBUTOR

CONVERSIONS Spanner & Socket Sizes

Head Size (Spanner Size, Across Flats)	Thread Size			
	German (BRD) metric according to DIN and ISO	France N F E 27-311 (69) 27-411 (69)	Sweden S M S 2164 - 1967 2175 - 1971	Metric for DIN 6914 - 6915
4	2		2 & 2.2	
4.5	2.3			
5	2.5		2.5	
5.5	3	3	3 & 3.5	
6	3.5	3.5		
7	4	4	4 & 4.5	
8	5	5	5	
9	5 Alt			
10	6	6	6	
11	7	7	7	
12				
13	8	8	8	
14	8 Alt			
15	10 KFZ			
16				
17	10	10	10	
18				
19	12	12	12	
20				
21				
22	14	14	14	12
23				
24	16	16	16	
25				
26				
27	18	18	18	16
28				18
30	20	20	20	
32	22	22	22	20
36	24	24	24	22
38				
41	27	27	27	24
46	30	30	30	27
50	33	33	33	
55	36	36	36	
60	39	39	39	
65	42	42	42	
70	45	45	45	
75	48	48	48	
80	52	52	52	
85	56	56	56	
90	60	60	60	
95	64	64	64	
100	68	68	68	
105	72	72	72	
110	76	76	76	
115	80	80	80	
120	85	85	85	
125				
130	90	90	90	
135	95	95	95	
140				
145	100	100	100	
150	105	105	105	
155	110	110	110	
160				
165	115	115	115	
170	120	120	120	

Head Size (Spanner Size, Across Flats)	Thread Size									
	AF	Inch Decimal	mm Equivalent	Unified Standard		ANSI B 18.2.1 - 1972				
				Nominal Series	Heavy Series	Nuts		Bolts & Screws		
						Square Bolt Hex Bolt Hex Cap Screw (Finished Hex Bolt) Lag Screw	Heavy Hex Bolt Heavy Hex Screw Structural Bolt	Hex Flat Hex Flat Jam Hex Jam Hex Slotted Hex Thick Slotted Hex Castle	Heavy Square Heavy Hex Flat Heavy Hex Flat Jam Heavy Hex Jam Heavy Hex Slotted	Square Nut
5/32	0.1562	3.97								
3/16	0.1875	4.76								
7/32	0.2187	5.56								
1/4	0.2500	6.35								
9/32	0.2812	7.14					No. 10			
5/16	0.3125	7.94								
11/32	0.3438	8.73								
3/8	0.3750	9.52								
13/32	0.4062	10.32								
7/16	0.4375	11.11	1/4		1/4		1/4		1/4	
1/2	0.5000	12.70	5/16	1/4	5/16		5/16	1/4		
9/16	0.5625	14.29	3/8	5/16	3/8		3/8	5/16	5/16	
19/32	0.5938	15.08								
5/8	0.6250	15.88	7/16		7/16				3/8	
11/16	0.6875	17.46		3/8			7/16	3/8		
3/4	0.7500	19.05	1/2	7/16	1/2		1/2	7/16	7/16	
25/32	0.7812	19.84								
13/16	0.8125	20.64	9/16		9/16				1/2	
7/8	0.8750	22.22		1/2		1/2	9/16	1/2		
15/16	0.9375	23.81	5/8		5/8		5/8	9/16		
1	1.0000	25.40							5/8	
1 1/16	1.0625	26.99		5/8		5/8		5/8		
1 1/8	1.1250	28.58	3/4		3/4		3/4		3/4	
1 1/16	1.1875	30.16								
1 1/4	1.2500	31.75		3/4		3/4		3/4		
1 5/16	1.3125	33.34	7/8		7/8		7/8			
1 3/8	1.3750	34.92								
1 7/16	1.4375	36.51		7/8		7/8		7/8		
1 1/2	1.5000	38.10	1		1		1		1	
1 5/8	1.6250	41.28		1		1		1		
1 11/16	1.6875	42.86	1 1/8		1 1/8		1 1/8		1 1/8	
1 3/4	1.7500	44.45								
1 13/16	1.8125	46.04		1 1/8		1 1/8		1 1/8		
1 7/8	1.8750	47.62	1 1/4		1 1/4		1 1/4		1 1/4	
2	2.0000	50.80		1 1/4		1 1/4		1 1/4		
2 1/16	2.0625	52.39	1 3/8		1 3/8		1 3/8		1 3/8	
2 3/16	2.1875	55.56		1 3/8		1 3/8		1 3/8		
2 1/4	2.2500	57.15	1 1/2		1 1/2		1 1/2		1 1/2	
2 3/8	2.3750	60.32		1 1/2		1 1/2		1 1/2		
2 7/16	2.4375	61.91			1 5/8					
2 9/16	2.5625	65.09				1 5/8		1 5/8		
2 5/8	2.6250	66.68	1 3/4		1 3/4					
2 3/4	2.7500	69.85		1 3/4		1 3/4		1 3/4		
2 13/16	2.8125	71.44			1 7/8					
2 15/16	2.9375	74.61				1 7/8		1 7/8		
3	3.0000	76.20	2		2					
3 1/8	3.1250	79.38		2		2		2		
3 3/8	3.3750	85.72	2 1/4		2 1/4					
3 1/2	3.5000	88.90		2 1/4		2 1/4		2 1/4		
3 3/4	3.7500	95.25	2 1/2		2 1/2					
3 7/8	3.8750	98.42				2 1/2		2 1/2		
4 1/8	4.1250	104.78	2 3/4		2 3/4					
4 1/4	4.2500	107.95		2 3/4		2 3/4		2 3/4		
4 1/2	4.5000	114.30	3		3					
4 5/8	4.6250	117.48		3		3		3		
4 7/8	4.8750	123.82			3 1/4					
5	5.0000	127.00						3 1/4		
5 1/4	5.2500	133.35				3 1/2		3 1/2		
5 3/8	5.3750	136.52						3 1/2		
5 5/8	5.6250	142.88				3 3/4		3 3/4		
5 3/4	5.7500	146.05						3 3/4		
6	6.0000	152.40			4			4		
6 1/8	6.1250	155.58						4		

Head Size (Across Flats)	Thread Size (Spanner Size)		
	Inch Decimal	mm Equivalent	BA & BSW
			BSF
0.152	3.86	8BA	
0.172	4.37	7BA	
0.193	4.90	6BA	
0.220	5.59	5BA	
0.248	6.30	4BA	
0.256	6.50	1 1/16W	
0.282	7.16	3BA	
0.297	7.54	3/32W	
0.324	8.23	2BA	
0.340	8.64	1/8W	(3/16)
0.365	9.27	1BA	
0.413	10.49	0BA	(7/32)
0.445	11.30	3/16W	1/4
0.525	13.34	1/4W	5/16
0.600	15.24	5/16W	3/8
0.710	18.03	3/8W	7/16
0.820	20.83	7/16W	1/2
0.920	23.37	1/2W	9/16
1.010	25.65	9/16W	5/8
1.100	27.94	5/8W	(1 1/16)
1.200	30.48	1 1/16W	3/4
1.300	33.02	3/4W	7/8
1.390	35.31	13/16W	(15/16)
1.480	37.59	7/8W	1
1.670	42.42	1W	1 1/8
1.860	47.24	1 1/8W	1 1/4
2.050	52.07	1 1/4W	1 3/8
2.220	56.39	1 3/8W	1 1/2
2.410	61.21	1 1/2W	1 5/8
2.580	65.53	1 5/8W	1 3/4
2.760	70.10	1 3/4W	2
76.70		1 7/8W	
3.150	80.01	2W	2 1/4
3.550	90.17		2 1/2
3.890	98.81		2 3/4
4.180	106.17		3
4.530	115.06		3 1/4
4.850	123.19		3 1/2
5.180	131.57		3 3/4
5.550	140.97		4
6.380	162.05		4 1/2

Weights & Measures CONVERSIONS

C = Centigrade
F = Fahrenheit
ft = Feet
g = Gram
gal = UK Gallon
hp = Horse Power

in = Inch
K = Kelvin
kg = Kilogram
km = Kilometre
Kw = Kilowatt
l = Litre

lb = Pound
mm = Millimetre
mtr = Metre
oz = Ounce
pt = UK Pint
yd = Yard

To Convert From Imperial	To Metric	Multiply By
°F	°C	°C=(°F -32) x 5/9
°F	°K	°K=°C + 271.3
ft	mtr	0.3048
ft ²	mtr ²	0.092903
ft ³	mtr ³	0.028317
ft-lbs	kg-m	0.13826
ft-tons	tonne-mtr	0.3097
gal	ltr	4.54609
gal/ft ²	ltr/m ²	48.905
grains/gal	gm/ltr	0.01425
hp	kw	0.7457
in	mm	25.40
in ²	cm ²	6.4516
in ²	mm ²	645.16
in ³	cm ³ (cc)	16.3871
in-tons	kg-m	25.8
lb	kg	0.45360
lb/ft	kg/m	1.488
lb/ft ²	kg/m ²	4.883
lb/ft ³	kg/m ³	15.020
lb/gall	kg/ltr	0.09983
lb/in ² (PSI)	kg/cm ²	0.07037
lb/in ² (PSI)	kg/mm ²	0.0007037
lb/in ² (PSI)	kg/mtr ²	703.7
lb/mile	kg/km	0.2818
lb/yd	kg/m	0.496
lb/yd ³	kg/m ³	0.5933
nautical mile	km	1.8532
miles	km	1.60934
miles ²	km ²	2.58999
oz	g	28.3495
pt	ltr	0.568261
tons	tonnes (1000kg)	1.01605
tons/ft	kg/m	3333.33
tons/ft ²	tonnes/m ²	10.936
tons/in ²	kg/mm ²	1.575
tons/in ²	n/mm ²	15.444
tons/yd	kg/m	1111.11
tons/yd ²	tonnes/m ²	1.215
tons/yd ³	tonnes/m ³	1.329
yd	mtr	0.9144
yd ²	mtr ²	0.836127
yd ³	mtr ³	0.764555

To Convert From Metric	To Imperial	Multiply By
°C	°F	°F=(°Cx9/5)+32
°K	°F	°F=(°K-271.3)x1.8+32
cm ²	in ²	0.155
cm ³ (cc)	in ³	0.06102
g	oz	0.035274
gm/ltr	grains/gal	70.156
kg	lb	2.2046
kg/cm ²	lb/in ² (PSI)	14.223
kg/km	lb/mile	3.548
kg/ltr	lb/gal	10.022
kg/m	lb/ft	0.672
kg/m	lb/yd	2.016
kg/m	tons/ft	0.0003
kg/m	tons/yd	0.0009
kg/m ²	lb/ft ²	0.2048
kg/m ³	lb/ft ³	0.0624
kg/m ³	lb/yd ³	1.686
kg/mm ²	lb/in ² (PSI)	1421.06
kg/mm ²	tons/in ²	0.635
kg/mtr ²	lb/in ² (PSI)	0.00142
kg-m	in-tons	0.03875
kg-m	ft-lbs	7.233
km	nautical miles	0.5396
km	miles	0.62137
km ²	miles ²	0.38610
kw	hp	1.341
ltr	gal	0.21997
ltr	pt	1.75975
ltr/m ²	gall/ft ²	0.0204
mm	in	0.03937
mm ²	in ²	0.00155
mtr	yd	1.09361
mtr	ft	3.28084
mtr ²	yd ²	1.19599
mtr ²	ft ²	10.76391
mtr ³	yd ³	1.30795
mtr ³	ft ³	35.31467
N/mm ²	tons/in ²	0.06475
tonne-m	ft-tons	3.229
tonnes (1000kg)	tons	0.9842
tonnes/m ²	tons/ft ²	0.0914
tonnes/m ²	tons/yd ²	0.823
tonnes/m ³	tons/yd ³	0.752

Metric Weight	Metric Surface Area
10 Milligrams	1 sqmtr
10 Centigrams	1 Centiares
10 Decigrams	10 Centiares
10 Grams	1 Deciare
10 Decagram	10 Deciares
10 Decagram	1 Are, (100 sq metres)
10 Hectograms	10 Ares
10 Kilograms	1 Dekare
10 Kilograms	1 Hectare (10,000 sqmtr)
10 Kilograms	100 Hectares
1 Myriagram	1 Sq km

Metric Length	Metric Capacity
10 Millimetres	10 Millilitres
10 Centimetres	1 Centilitre
10 Decimetres	10 Centilitres
10 Decimetres	1 Decilitre
10 Meters	10 Decilitres
10 Decametres	1 Litre
10 Hectometres	1 Decalitre
10 Hectometres	10 Decalitres
10 Kilometres	1 Hectolitre
10 Kilometres	10 Hectolitres
1 Metre	1 Kilolitre

Apothecaries' Weight	Apothecaries' Fluid Measure
<i>Used for Dispensing Drugs, etc.</i>	
20 Grains	1 Dram
3 Scruples	1 Ounce
8 Drams	1 Pint
12 Ounces	1 Gallon

Troy Weight	
24 Grains	1 Pennyweight
20 Pennyweight	1 Ounce (480 Grains)
12 Ounces	1 Pound (5760 Grains)

Diamonds and Pearls are weighed by Carats, of 4 grains each (equal to 3.2 Troy grains). The Troy ounce is equal to 150 Diamond Carats. Gold, when pure, is 24 Carats fine; if it contains one part alloy it is said to be 23 Carats, and so on.

Imperial Weight (Avoirdupois)	Imperial Surface Area
<i>Used for General Merchandise</i>	
16 Drams	1 Square foot
16 Ounces	1 Square yard
14 Pounds	1 Square pole
28 Pounds	1 Rood
100 Pounds	1 Acre
4 Quarters	1 Square mile
2000 Pounds	
20 Hundredweight	

7.92 inches is equal to one hundredth of a "Gunter's Chain" (22 yards) which is (was) commonly used by surveyors. An "Engineer's link" is equal to 12 inches and a chain is therefore 33 1/3 yards (100 feet)

Imperial Cubic Capacity	
1728 Cubic Inches	1 Cubic Foot
27 Cubic Feet	1 Cubic Yard
5 Cubic Feet	1 Barrel Bulk
40 Cubic Feet	1 Ton Shipping
40 Cubic Feet	1 Load Hard Timber
50 Cubic Feet	1 Load Foreign Fir

Avoirdupois pounds are greater than Troy in the proportion of 17 to 14 approx; Troy ounces are greater than Avoirdupois in the proportion of 79 to 72 approx.

Imperial Length	Imperial Capacity
<i>Used for Liquids and Dry Goods</i>	
3 Barleycorns	1 Pint
4 Inches	1 Quart
7.92 Inches	1 Gallon
9 Inches	1 Peck
12 Inches	1 Bushel
18 Inches	1 Quarter
30 Inches	1 Load
3 Feet	1 Chaldron
37.2 Inches	
45 Inches	
5 Feet	
6 Feet	
5 1/2 Yards	
4 Poles	
100 Links	
10 Chains	
220 Yards	
608 Feet	
8 Furlongs	
10 Cables	
1 Nautical Mile	
1 Knot	
3 Miles (land)	

A bushel of wheat on an average weighs 60 pounds; of barley, 47 pounds; of oats, 40 pounds. The gallon contains 10 pounds avoirdupois of distilled water.

Decimal Capacity				
Pints	Gallon	Cub.Ft.	Litres	
1	0.125	0.0200	0.568	
8	1.000	0.1604	4.544	
16	2.000	0.3208	9.082	

